

ZTH4014  
Telehandler Operation Manual

**ZOOMLION INTELLIGENT ACCESS MACHINERY CO.,LTD.**

Add:701 Xulong Nan lu, Xiangjiang New District, Changsha, Hunan,PRC  
Email:awm@zoomlion.com

Zip Code:410200  
Tel:400-800-0157



**ZOOMLION**

ZTH4014  
Telehandler Operation Manual

2024.12 A



## Foreword

Zoomlion appreciates your choice of our machine for your application. The Operation and Safety Manual must be read and understood in its entirety before operating the machine.

This manual introduces you safety information, significant technical specs, safety operation in detail for working efficiency improving. Keep this manual properly at all times for looking up.

Do not operate the machine if there is any doubt in operation, please consult local service team for troubleshooting. Zoomlion Intelligent Access Machinery Co., Ltd. does not take the consequence of wrong operation. Zoomlion Intelligent Access Machinery Co., Ltd. does not take the consequence of wrong operation.

This manual should be considered a permanent part of your machine and should remain with the machine at all times.

The content is under intellectual property protection, permission is required for a copy or other application.

There might be some tiny differences in details between your machine and the upgraded one due to the continuous improving. For clarification, questions, or additional information regarding any portions of this manual, contact local service team.

Our company reserves the right to modify this manual as technical improvement without notice.

Thank you for your trust and support for Zoomlion products!

Zoomlion Intelligent Access Machinery Co., Ltd

## Safety Precaution Icons

This manual has the following safety precaution icons:



Failure to comply with the safety precautions listed in this manual could result in personal injury or death.



Failure to comply with the safety precautions listed in this manual could result in potential personal injury or death.



Failure to comply with the safety precautions listed in this manual could result in potential mild personal injury.



Indicates risks unrelated with personal injury (such as property damage).

# Contents

<b>Foreword</b> .....	<b>I</b>
<b>Safety Precaution Icons</b> .....	<b>II</b>
<b>Content</b> .....	<b>III</b>
<b>SECTION ONE SAFETY PRECAUTIONS</b> .....	<b>1-1</b>
1.1 General .....	1-1
1.2 Pre-operation cautions .....	1-1
1.3 Hazard Classification.....	1-2
1.4 Intended use.....	1-2
1.5 Safety Alert Symbols and Maintenance.....	1-3
1.6 Safety Operation.....	1-7
1.6.1 Operator safety .....	1-7
1.6.2 Workplace safety .....	1-7
<b>SECTION TWO MACHINE COMPONENTS AND CONTROLS</b> .....	<b>2-1</b>
2.1 Machine Components .....	2-1
2.2 Cab control and indicators.....	2-2
2.2.1 Ignition key switch .....	2-4
2.2.2 Emergency stop switch .....	2-4
2.2.3 Multi-functional joystick .....	2-5
2.2.4 USB interface .....	2-5
2.2.5 IO Module Switch Assembly .....	2-6
2.2.6 Seat .....	2-8
2.2.7 Safety belt .....	2-9
2.2.8 Override switch .....	2-9
2.2.9 Steering gear .....	2-10
2.2.10 Display.....	2-12
2.2.11 Gradienter .....	2-23
2.2.12 Rear window.....	2-23
2.3 Power management module.....	2-23
2.4 Anti-tilting system .....	2-24
2.5 Front headlight .....	2-25
2.6 Tail light.....	2-26
2.7 Rotation alarm light.....	2-26
2.8 Boom support .....	2-27
2.9 Remote (if equipped).....	2-27

## Contents

2.10 Hydraulic fast changing pin (option).....	2-29
<b>SECTION THREE MACHINE INSPECTION.....</b>	<b>3-1</b>
3.1 General .....	3-1
3.1.1 Pre-start inspection principle .....	3-1
3.1.2 Pre-start inspection .....	3-1
3.1.3 Machine starting inspection.....	3-2
3.2 Workplace Inspection .....	3-3
3.2.1 Workplace inspection principle.....	3-3
3.2.2 Workplace inspection.....	3-3
3.3 Decal Inspection .....	3-4
<b>SECTION FOUR OPERATION INSTRUCTION .....</b>	<b>4-1</b>
4.1 General .....	4-1
4.2 Engine Operation.....	4-1
4.2.1 Start engine .....	4-1
4.2.2 Cold start .....	4-2
4.2.3 Turn off the machine and park.....	4-3
4.2.4 Spark extinguisher (optional).....	4-3
4.2.5 Heater (optional).....	4-4
4.2.6 Turn off the machine and park.....	4-4
4.3 Driving Operation.....	4-5
4.3.1 Machine start .....	4-5
4.3.2 Park.....	4-5
4.3.3 Drive on slope.....	4-6
4.4 Outriggers Retract .....	4-6
4.5 Frame Level (if equipped) .....	4-6
4.6 Move goods .....	4-7
4.6.1 Pick up goods on ground .....	4-7
4.6.2 Place goods .....	4-8
4.7 Attachment fast change .....	4-9
4.8 Attachment select .....	4-10
4.9 Traction operation.....	4-10
4.10 Suspended cargo transport.....	4-11
4.11 Connecting device- Hoisting rings .....	4-11
4.12 Engine regeneration (if equipped) .....	4-11

## Contents

4.13 Load chart instruction .....	4-13
4.14 Air condition (if equipped) .....	4-14
4.14.1 Refrigeration mode .....	4-14
4.14.2 Heating mode.....	4-14
<b>SECTION FIVE MAINTENANCE .....</b>	<b>5-1</b>
5.1 General .....	5-1
5.1.1 Maintenance symbols diagram .....	5-1
5.1.2 Pre-Start Inspection .....	5-1
5.1.3 Maintenance hazard .....	5-2
5.1.4 Body injury hazard .....	5-2
5.2 Maintenance schedule .....	5-3
5.3 Power system maintenance.....	5-5
5.3.1 Engine oil.....	5-5
5.3.2 Fuel inspection.....	5-6
5.3.3 Coolant level inspection .....	5-7
5.3.4 Fuel filter maintenance .....	5-8
5.3.5 Air filter maintenance .....	5-9
5.3.6 Engine oil filter maintenance .....	5-9
5.3.7 Urea pump filter element maintenance (if any, Euro V configuration above 56kW)...	5-10
5.3.8 Urea tank filter element maintenance (if any, Euro V configuration above 56kW).....	5-10
5.3.9 DPF filter element maintenance (if any, China IV, Euro V configuration) .....	5-10
5.3.10 Radiator maintenance .....	5-11
5.3.11 Engine regeneration (China IV, Euro V).....	5-12
5.3.12 Engine maintenance.....	5-13
5.4 Transfer Case Maintenance .....	5-14
5.4.1 Transfer case oil level check .....	5-14
5.4.2 Transfer case oil replacement .....	5-14
5.5 Machine Lubricating Points.....	5-15
5.6 Drive Axle Maintenance .....	5-18
5.6.1 Drive axle differential gear .....	5-18
5.6.2 Wheel reducer.....	5-19
5.7 Tire .....	5-20
5.7.1 Tire pressure .....	5-20
5.7.2 Wheel installation .....	5-20
5.8 Boom maintenance .....	5-21

## Contents

5.8.1 Boom lubrication .....	5-21
5.8.2 Slider.....	5-21
5.8.3 Boom expansion plate chain maintenance .....	5-22
5.9 Hydraulic System Maintenance.....	5-23
5.9.1 Hydraulic oil .....	5-23
5.9.2 Return oil filter element.....	5-25
5.9.3 Hydraulic tank .....	5-25
5.9.4 Hydraulic hose testing and replacement conditions.....	5-26
5.10 Brake System Maintenance .....	5-26
5.10.1 Brake oil .....	5-26
5.10.2 Brake system exhaust .....	5-26
5.11 Cab Maintenance .....	5-27
5.11.1 Wiper cleaning liquid.....	5-27
5.11.2 Cab venting filter element.....	5-28
5.12 Electrical System Maintenance.....	5-28
5.12.1 Anti-tilting system .....	5-28
5.12.2 Battery .....	5-29
5.13 Air Condition System .....	5-30
<b>SECTION SIX TRANSPORTATION AND STORAGE.....</b>	<b>6-1</b>
6.1 Transportation.....	6-1
6.1.1 Train or ship transportation.....	6-1
6.1.2 Flat-bed trailer transportation .....	6-2
6.2 Storage condition.....	6-4
<b>SECTION SEVEN TECHNICAL PARAMETERS .....</b>	<b>7-1</b>

# **ZOOMLION**

## **Telehandler Operation Manual**

### **Section 1 SAFETY PRECAUTIONS**

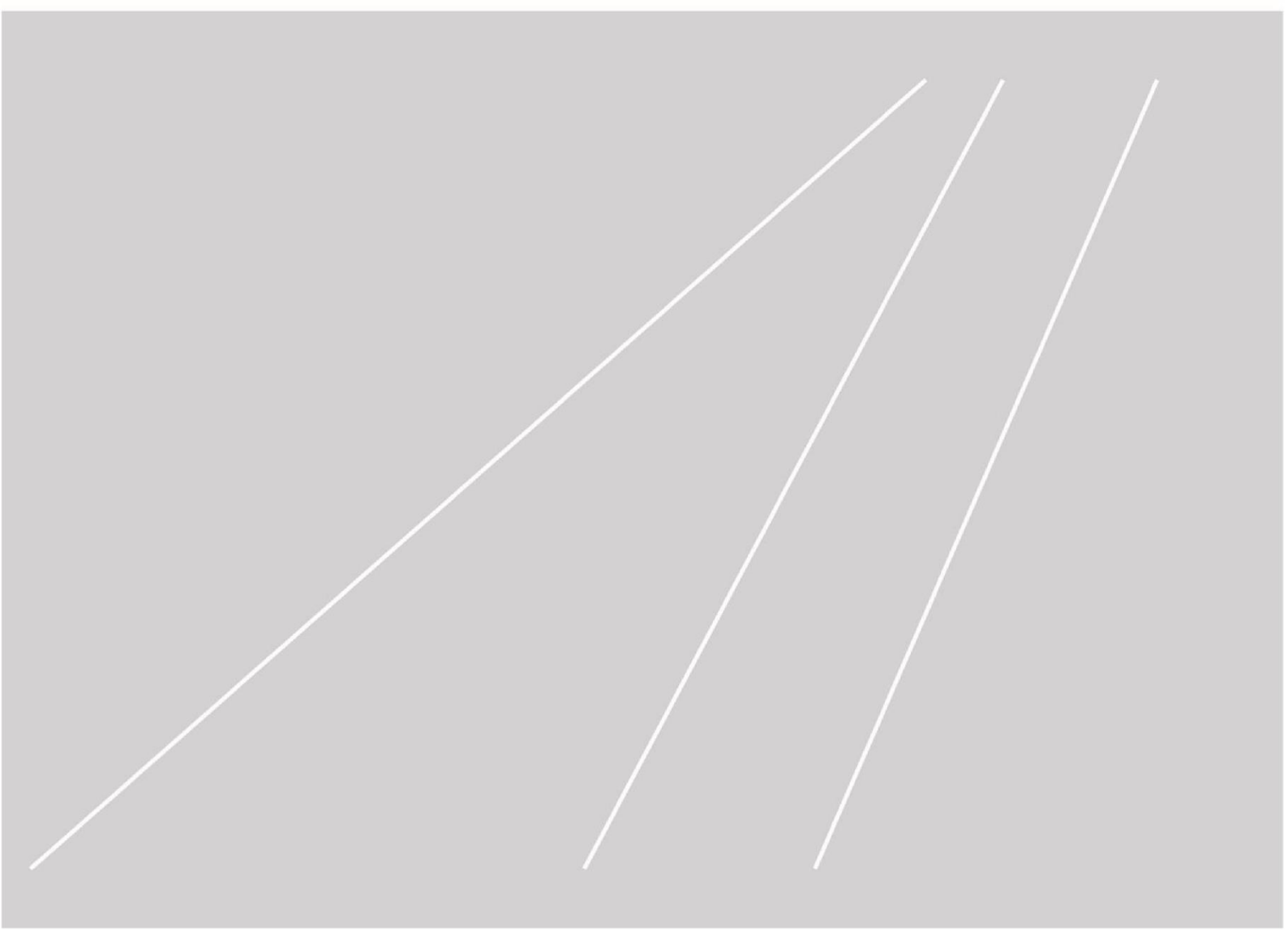



## SECTION 1 SAFETY PRECAUTIONS

### 1.1 General

To Owners/Users/Operators:

Zoomlion appreciates your choice of our machine for your application. We put operator safety at the first place, and it is best achieved by our joint efforts. The following requirements need to be adhere to for the purpose of safety operating:

- a) Obey all user rules, job site regulations and governmental regulations.
- b) Read, understand and obey all operating instructions on the machine and in this manual.
- c) Keep good safety operating conventions.
- d) Allow only those authorized and qualified personnel to operate the machine under the supervision of an experienced and qualified operator.
- e) An operator must not operate the machine if he has any doubts.

Zoomlion appreciates your choice of our machine for your application.

### 1.2 Pre-operation cautions



Failure to comply with the safety precautions listed in this manual could result in personal injury or death.

An operator must not operate the machine, only if:

- a) He has learned and practiced the principles of safe machine operation contained in this operational manual;
  - 1) Avoid hazardous situations;
  - 2) Be aware of safety rules before further operation;
  - 3) Perform a pre-operation inspection at all times;
  - 4) Implement functional test before operating the machine at all times;
  - 5) Inspect job site;
  - 6) Only use the machine as it was intended.
- b) Read, understand and obey the manufacturer's instructions and safety rules—safety and operator's manuals and machine decals;
- c) Read, understand and obey employer's safety rules and work site regulations;
- d) Read, understand and obey all applicable governmental regulations;
- e) The operator is properly trained to safely operate the machine.

### 1.3 Hazard Classification

Decals on this machine use symbols, color coding, and signal words to identify the following:



Safety alert symbol—used to alert you to potential personal injury hazards. Obey all safety messages that follow this symbol to avoid possible injury or death.



Indicates a hazardous situation which, if not avoided, will result in death or serious injury. This decal will have a red background.



Indicates a hazardous situation which, if not avoided, could result in death or serious injury. This decal will have an orange background.



Indicates a hazardous situation which, if not avoided, could result in minor or moderate injury. This decal will have a yellow background.



Indicates a property damage message. This decal will have a blue background.

### 1.4 Intended use

This machine is intended to be used only to lift personnel, along with their tools, and materials to an aerial work site.

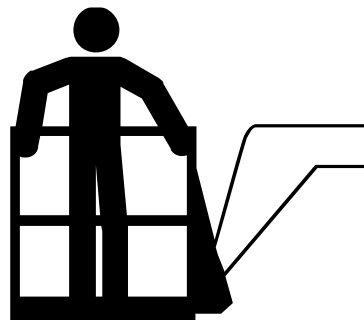

It is prohibited to use telehandler lift personnel without a working platform. Work platform shall not be overloaded referring to platform capacity. Only trained and qualified staff are allowed on board!

ZOOMLION accessories designed for lifting personnel (optional platform, contact your dealer to purchase)



When there are workers on the platform, the vehicle is prohibited to drive.

### **1.5 Safety Alert Symbols and Maintenance**

Replace any missing or damaged safety signs. Operator must keep safety awareness in mind at all times. Use mild soap and water to clean safety signs. Do not use solvent-based cleaners because they may damage the safety sign material.

				
Lifting point	Liquid spray hazard	Card for leak point	Maintain shaft collar	Tipping over hazard
				
Crushing hazard	Away from moving parts	Overturning hazard	Fasten safety belt	Keep safety distance
				
Fall over hazard	No climbing	Overturning hazard	Read work range and operator manual	Smashing hazard
				
Away from working zone	Collision hazard	No smoking, No flame	Explosion hazard	Tie down point
				
Disassembly as instruction	Crushing hazard	Away from moving parts	Fall over from accessories	Standard platform only

Figure 1-1 Symbol and Hazard Pictorials Definitions

				
Load swing will cause machine overturning, resulting in serious injury or death.	Keep slow speed, proper operation and use two lanyards	Extra load referring to load curve	Overturning hazard	Overturning hazard
				
No personnel nearby except operator	Lower fork or load fall over causing serious injury or death	No stepping	Explosion/Burn hazard	No smoking, No flame
				
Disconnect battery as instruction	Battery explosion hazard	Dry Nitrogen only for charging	Energy accumulator explosion hazard	Away from outrigger
				
Emergency exit	No obstacles around when operating	Boom level or lowered when driving	No rotating if the boom angle above 0°	Open cab door
				
Neutral gear	Preheating	Lifting and driving	Trained and authorized operator only	Burn hard
				
Not loose cover before cooling	No touch	Engine explosion hazard	No ether or other booster	Pinch hazard

Figure 1-1 Symbol and Hazard Pictorials Definitions (cont.)





				
Away from rotating parts	High temperature surface	No touch	Cooling system pressuring Operate slowly	Hydraulic tank

Figure 1-1 Symbol and Hazard Pictorials Definitions (cont.)

## 1.6 Safety Operation

### 1.6.1 Operator safety

Only qualified and authorized technicians are allowed to use telehandlers. A written authorization letter must be issued by the relevant department, and the operator must hold the authorization letter permanently.

Operator instruction:

- a) Regardless of working experience, operators should be familiar with the position and operation of all controllers and instruments before operation.
- b) Wear properly and avoid wearing loose clothing.
- c) Wear proper protective gear.
- d) Working in a noisy environment for too long may cause hearing problems. It is recommended to wear earmuffs to avoid excessive noise.
- e) Always face the machine when getting into or out of the driving seat and use handles designed for this purpose. Do not jump out of the driver's seat.
- f) Always pay attention when operating the machine. Do not use radios, headsets or earphones.
- g) When hands or feet are wet or dirty with grease, it is forbidden to operate the machine.
- h) The driver's seat could be adjusted as required for comfort and positioned properly in the cab.

#### CAUTION

It is not allowed to adjust the seat when operating.

- a) The operator must be in a standard position in the cab at all times. Do not reach your arms, legs or any part of your body out of the cab.
- b) Safety belts must be fastened and adjusted to operator size.
- c) Under any circumstances, it is strictly prohibited to use the control unit for unintended purpose (such as boarding or jumping off the telehandler, luggage, etc.).
- d) If the control components are fitted with a forced operation device (lever lock), do not leave the cab before placing these control components in neutral position.
- e) No persons other than the driver are allowed in the cab.

### 1.6.2 Workplace safety

#### DANGER

This machine is not electrically insulated and will not provide protection from contact with or proximity to electrical current.

- a) Obey all local and governmental regulations regarding required clearance from electrical power lines. At a minimum, the required clearance contained in the chart below must be followed.

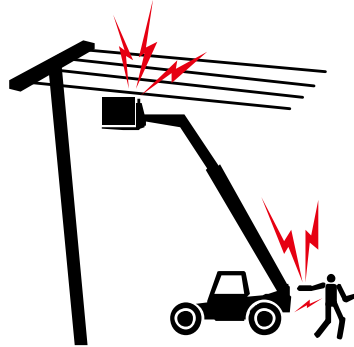

Table 1-1 Required Clearance

No.	Line Voltage	Required Clearance
1	0 to 50 KV	3.0 m
2	50 to 200 KV	4.6 m
3	200 to 350 KV	6.1 m
4	350 to 500 KV	7.6 m
5	500 to 750 KV	10.6 m
6	750 to 1000 KV	13.7 m

- b) Allow for platform movement, electrical line sway or sag, and beware of strong or gusty winds.
- c) Keep away from the machine if it contacts energized power lines. Personnel on the ground or in the platform must not touch or operate the machine until energized power lines are shut off.



Do not operate the machine during lightning or storms.

Do not use the machine as a ground for welding.

**⚠ DANGER**

Do not use the machine when wind speeds may exceed 12.5 m/s.

If wind speeds exceed 12.5 m/s when the boom is raised, lower the boom and do not continue to operate the machine. Do not operate the machine in strong or gusty winds. Do not increase the surface area of the platform or the load. Increasing the area exposed to the wind will decrease machine stability.

Table 1-3 Beaufort scale

Beaufort scale	Wind speed (m/s)	Instruction
0	0.0-0.2	Calm
1	0.3-1.5	Light air
2	1.6-3.3	Light breeze
3	3.4-5.4	Gentle breeze
4	5.5-7.9	Moderate breeze
5	8.0-10.7	Fresh breeze
6	10.8-13.8	Strong breeze
7	13.9-17.1	Moderate gale
8	17.2-20.7	Fresh gale
9	20.8-24.4	Strong gale

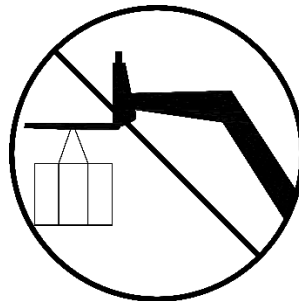

It is forbidden to use forks to lift goods. If cargo needs to be lifted, special lifting equipment must be used.

Drilling holes in forks is prohibited.

When loading the cargo, the forks must be centrally located and as far apart as possible.



Crashing hazard when using platform:

- a) Mind the sight range and blind spots;



- b) Check the working area for overhead obstacles or other possible dangers;



- c) Beware of the risk of crushing when holding onto the platform guardrail;  
 d) Users must comply with user rules, workplace rules and government rules governing the use of personal protective equipment.

### DANGER

Overturning hazard

- a) For additional load requirements, the load requirements in the operation curve shall be met;

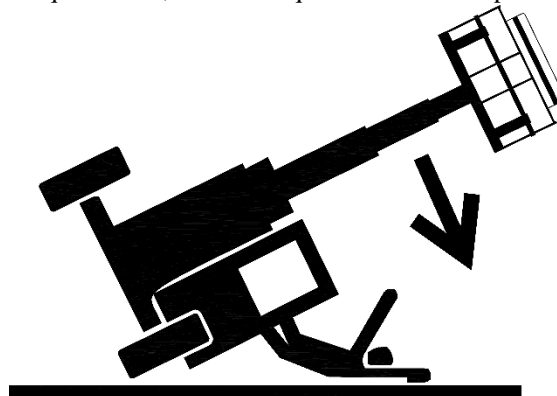

- b) Do not use accessories without working curves that are not commissioned by the original Equipment Manufacturer;  
 c) Loading goods according to the working curve in the cab;  
 d) No overloading;  
 e) Pavement could support equipment;

- f) Mind the wind speed, strong winds may cause the cargo to swing and produce partial load, thus increasing the risk of equipment tipping over.
- g) Keep a minimum distance of 0.6m on level ground from potholes, obstacles, hidden potholes, etc., that cause the equipment to tip over.
- h) It is prohibited to raise the boom when the frame is not level unless expressly indicated in the lifting performance table;

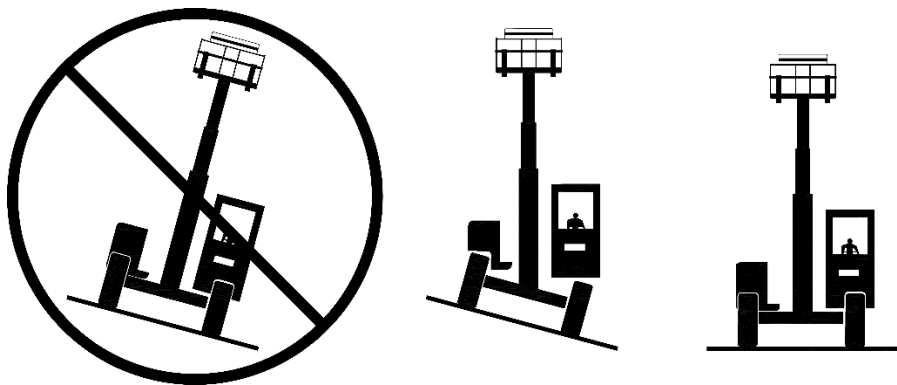

- i) When the boom lifting angle exceeds 0°, it is forbidden to use the frame leveling function to tilt the frame.

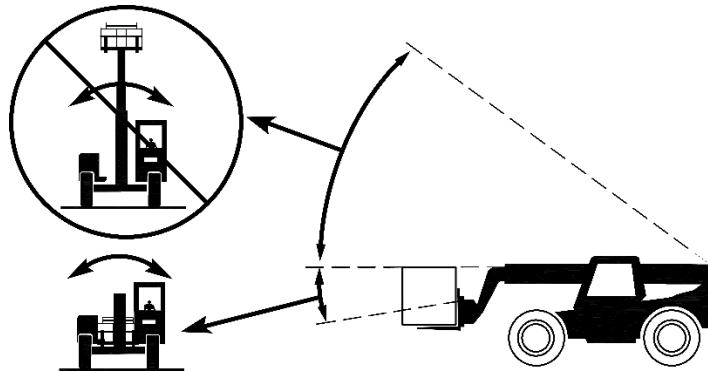

**! DANGER**

Pinch hazard

- a) Do not touch the boom when extending to avoid being pinched.

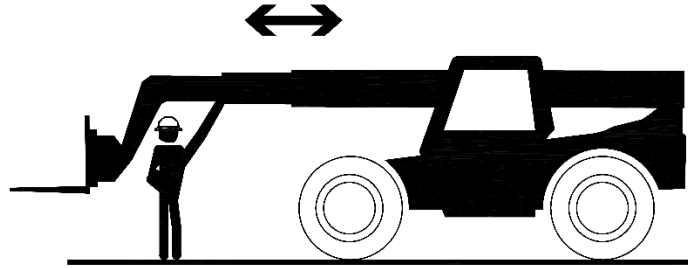

- b) Do not touch the levelling cylinder to avoid being pinched.

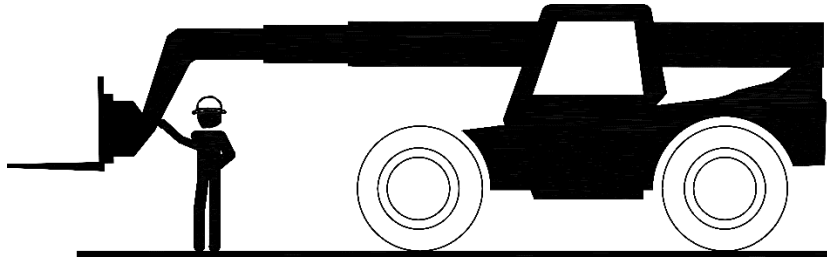

- c) Do not touch the joint between the fork and the connecting device to avoid being pinched.

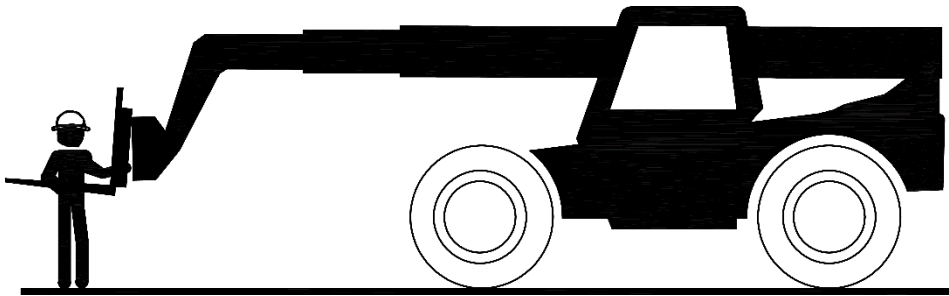

- d) Keep a safe distance from the equipment when traveling.

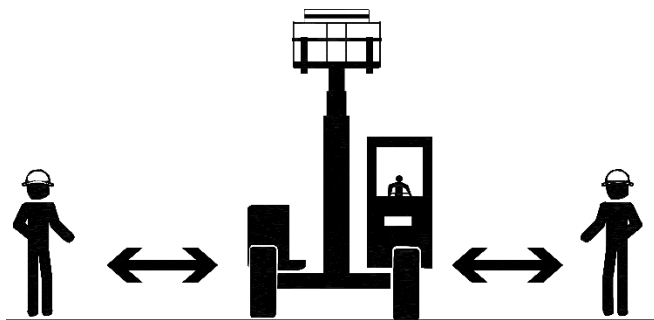

- e) No personnel under the boom or fork.

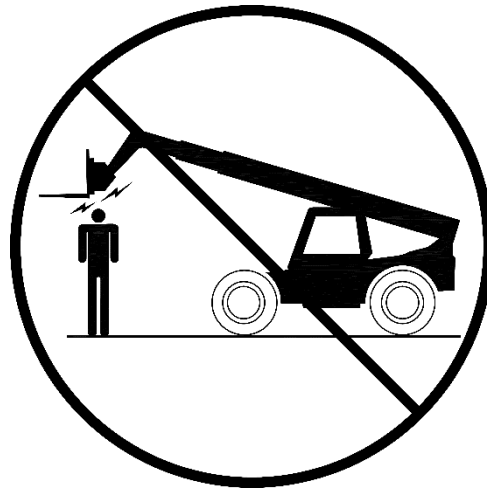

- f) Keep away from pinch points on the equipment, and keep away from moving parts of the engine when the engine is running, such as the engine belt.



- g) Keep away from tires and frame.

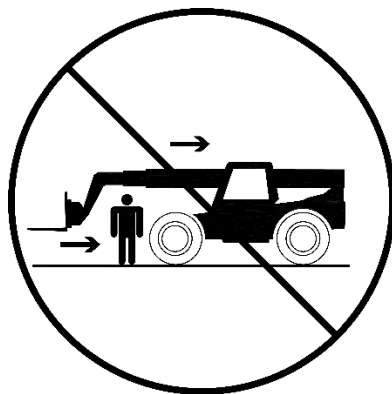

**⚠ DANGER**

Fall over hazard

- a) When entering and exiting the cab, please use the steps below the driver and the armrest on the cab. Always use the "three-point contact method" to enter and exit the cab. Do not grab the operating lever or the steering wheel when entering and exiting the cab.

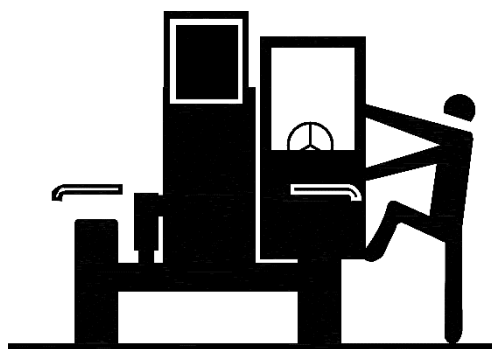

- b) Do not take people on board, lest they fall from the equipment and cause serious injury.



### DANGER

#### Body Injury Hazard

- a) Always operate the machine in a well-ventilated area to avoid carbon monoxide poisoning;
- b) Do not operate a machine with a hydraulic oil or air leak. An air leak or hydraulic leak can penetrate and/or burn skin;
- c) Improper service with components under hood will cause serious injury. Only trained maintenance personnel should access compartments.

Suggestion: access by the operator is only advised when performing a pre-operation inspection. All covers must remain closed and secured during operation.

### DANGER

#### Explosion and Fire Hazards

- a) Do not start the engine in hazardous locations where potentially flammable or explosive gases or particles such as liquefied petroleum gas (LPG), gasoline, or diesel may be present.
- b) Do not refuel the machine when engine is running.
- c) Refuel the machine or charge the battery only when the machine locates in an open and ventilated locations where potentially flammable or explosive gases or particles do not present.
- d) Do not operate the machine in hazardous locations where potentially flammable or explosive gases or particles may be present.

**! DANGER**

## Damaged Machine Hazard

- a) Do not use a damaged or malfunctioning machine. Conduct a thorough pre-operation inspection of the machine and test all functions before each work shift.
- b) Immediately tag and remove from service a damaged or malfunctioning machine;
- c) Be sure all maintenance has been performed as specified in this manual and the appropriate Zoomlion service manual;
- d) Be sure all decals are in place and legible;
- e) Be sure operational and maintenance manuals are complete, legible, and in the storage container located on the machine.

**! DANGER**

## Component Damaged Hazard

- a) Do not charge the battery with a charger greater than 12V.
- b) Do not use the machine as a ground for welding.
- c) Do not charge with unmatched power.
- d) Do not use the machine where there may be a strong magnetic field.

**! DANGER**

## Burn hazard

- a) Batteries contain acid. Always wear protective clothing and eye wear when working with batteries.



- b) Avoid spilling or contacting battery acid. Neutralize battery acid spills with baking soda and water.
- c) Do not expose the battery or charger in water or rain while charging.

**! DANGER**

## Explosion hazard

- a) Keep sparks, flames, and lighted tobacco away from batteries. Batteries emit explosive gas.



- b) Do not use tools which could produce flames to contact battery terminals or cable clamp.

### DANGER

#### Body Injury Hazard

- a) Conduct daily check with wires and cables.
- b) Change damaged items prior to operation. Avoid contact with battery terminals. Remove all rings, watches and jewelry.

# **ZOOMLION**

## **Telehandler Operation Manual**

### **Section 2 MACHINE COMPONENTS AND CONTROLS**





## SECTION 2 MACHINE COMPONENTS AND CONTROLS

### 2.1 Machine Components

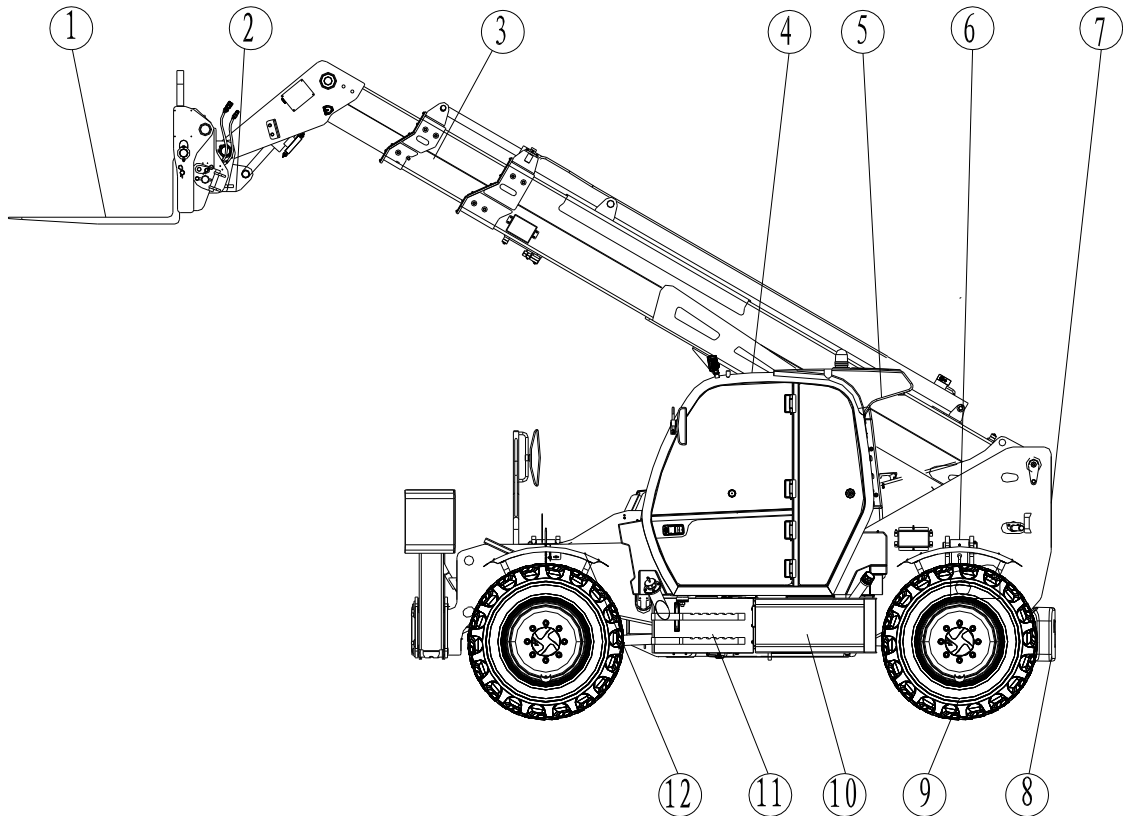

Figure 2-1 Components

Table 2-1 Component Instruction

No.	Item	No.	Item
1	Accessories pack	7	Frame assembly
2	Connecting device	8	Counterweight assembly
3	Boom assembly	9	Drive system
4	Cab assembly	10	Hydraulic system assembly
5	Air condition	11	Power system assembly
6	Suspension system	12	Hood assembly

### 2.2 Cab controls and indicators

#### CAUTION

The manufacturer has no direct control over machine application and operation. The user and operator are responsible for conforming with good safety practices.



Figure 2-2 Cab



Figure 2-3 Indicators

Table 2-2 Cab and indicators

No.	Item	No.	Item
1	Ignition key switch	10	Steering gear
2	Emergency stop Switch	11	Display
3	Multi-function joystick	12	Left door lock
4	IO module switch assembly	13	Left door lock
5	Seat	14	Upper rear door lock
6	Safety belt	15	Rear window lock
7	Accelerator	16	Display
8	Brake pedal	17	Gradienter
9	Override switch	18	Main power switch

**CAUTION :** All terms such as "right, left, front, back" are based on the person sitting in the driver's seat and looking forward.

## 2.2.1 Ignition key switch



Figure 2-4 Ignition key switch

Three gear: off, on and start

- a) off: Initiate state, power off
- b) on: Power on
- c) start: turn the key switch to Start from Off or On, start the engine.

**Remind :** after the engine starts, release the key switch and it backs to ON automatically.



When the ignition key switch is in the other two positions except OFF, the key cannot be removed.



When the device is turned off, the ignition key switch must be placed in the “OFF” position to prevent battery running out.

## 2.2.2 Emergency stop Switch

In emergency, press the button to turn off the engine, cut off the power supply of the vehicle and stop all actions; Pull up the button to restore the machine power supply.

### 2.2.3 Multi-function joystick

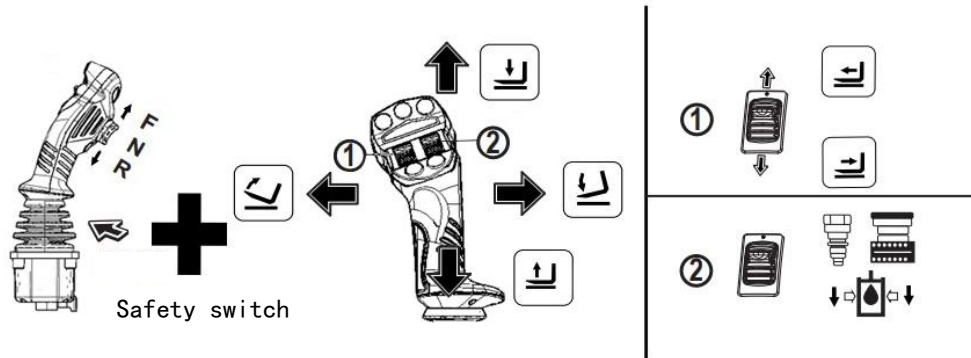

Figure 2-5 Multi-function joystick

- Push the joystick forward to lower the boom; Back to lift the boom; Left to make the fork lean backward; Right to make the fork tilt forward;
- Left roller UP to extend the boom; DOWN to retract the boom. The right roller UP to extend the reserved accessories; DOWN to retract the reserved accessories.
- FNR is located below the the joystick, and the forward key is "F" gear; the middle key is "N" gear; press the button backward to the "R" gear.

#### **CAUTION**

Press the multi-function joystick safety switch to control boom lifting, boom extension, fork pitching, accessories reservation, etc..

### 2.2.4 USB interface

USB interface provides charging and audio playback, audio playback see the display.

### 2.2.5 IOIO module switch assembly



Figure 2-6 IO module switch assembly

Table IO module switch assembly instruction

No.	Item	No.	Item
1	Emergency mode switch	7	Park mode switch
2	Remote mode switch	8	High/Low speed mode switch
3	ECO mode switch	9	Left outrigger extension switch
4	Fork straight line switch	10	Right outrigger extension switch
5	Regeneration switch /Regeneration disabled switch	11	Frame leveling switch
6	Steering mode switch	12	Knob speed control switch

- a) Emergency mode switch: When the emergency mode switch is pressed, the machine enters the emergency power state, and only the retracting and descending actions of the boom can be operated

at this time;



After emergency power is started, engine starting operation is invalid.

- b) Remote mode switch: default as Cab mode. Press the button to switch to Remote mode;



After the vehicle enters the remote control mode, the cab starts the engine operation is invalid.

When the cab mode is switched to remote control mode, the engine will automatically turn off if it has started.

- c) ECO mode switch: press to enter the energy saving mode, the indicator is on;
- d) Fork straight line switch : press to enter the fork straight line mode;
- e) Regeneration switch /Regeneration disabled switch: press forward for parking regeneration, press back for parking regeneration ban;



If enter the regeneration, you must receive the engine regeneration demand, press and hold the engine parking regeneration switch for more than 3 seconds, while the vehicle is in the parking state, and each operation handle and accelerator pedal are in the initial state. This switch is automatically turned off after parking regeneration.



In the process of parking regeneration, if the parking or operation handle or accelerator pedal is released, the parking regeneration will automatically exit.



The engine parking regeneration operation is invalid when the engine regeneration disable is activated.



**CAUTION :** press and hold engine regeneration prohibiting switch for more than 3 seconds to activate.

- f) Steering mode switch: default as Front wheel steering mode, push forward for Crab steering mode, and pull back for 4WS mode;



Front wheel steering



Crab steering



4WS

- g) Park mode switch: select parking brake switch, the indicator ON that the parking brake activated; if the indicator OFF, the parking brake released.
- h) High/Low speed mode switch : able to switch to high/low gear

- i) The left outrigger expansion switch, press the left front outrigger forward to extend, press the left front outrigger back to retract;
- j) The right outrigger expansion switch, press the right front outrigger forward to extend, press the right front outrigger back to retract;

### ⚠ CAUTION

**CAUTION :** Raise the outrigger only when boom has been fully retracted and the boom angle is less than 50°.

- k) Frame leveling switch: Press the rear frame to the right, press the rear frame to the left;

### ⚠ CAUTION

**CAUTION :** Frame tilt can be adjusted only if the boom angle is less than 30°.

- l) Knob speed control switch : Turn the knob to adjust the maximum speed of the boarding movement, and at the same time, a proportional indicator bar appears on the display screen.

## 2.2.6 Seat

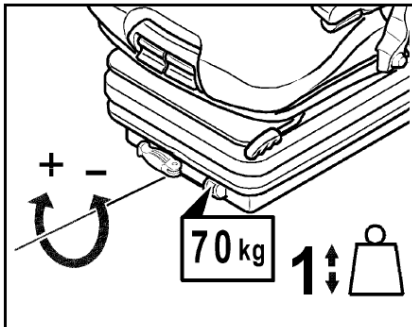

### Weight adjustment

The driver's weight adjustment is realized by rotating the weight adjustment handle of the seat when the seat is empty, and the body mass index can be read by the indicator.

### ⚠ CAUTION

**CAUTION :** In order to avoid injury, the driver's weight adjustment settings must be checked and adjusted before starting the machine.

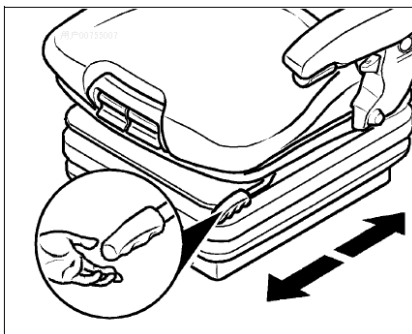

### Forward and backward adjustment

Lift the rod to adjust front and rear stroke.

- Adjusted to the proper position, the rod must be locked and have a locking sound. When locked, the driver's seat cannot move.
- Do not lift the lock rod with your thighs and calves.

**! WARNING**

**Accident risk! Do not operate the pull rod while driving.**

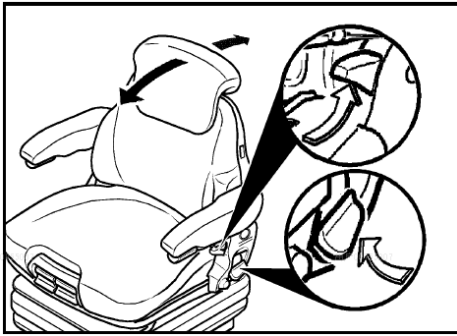
**Backrest adjustment**

When lifting the adjusting handle of the backrest (indicated by the arrow), the proper angle of the backrest is achieved by applying a load to the backrest forward or backward, and then releasing the adjusting handle, the backrest locks.

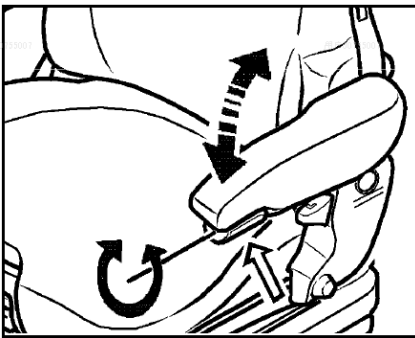
**Handrail adjustment**

The angle of the handrail can be adjusted independently. If you need to adjust the angle of the handrail, you can adjust the angle of the handrail by turning the roller under the handrail clockwise or counterclockwise.

### 2.2.7 Safety belt

After ensuring that the operator is properly seated in the seat and that the belt strap is not twisted, pass the belt through the front of the body and tie it around the waist.

**! DANGER**

**Adjust the excess length of the belt according to your body size to avoid pressing the waist too tight.**

### 2.2.8 Override switch

The override switch is a self-resetting key switch. When the anti-tipping system is cut off, you can turn the switch clockwise to the right limit to enable the override function. The override function is only used during debugging or maintenance, and is strictly prohibited during normal operation.

### 2.2.9 Steering gear

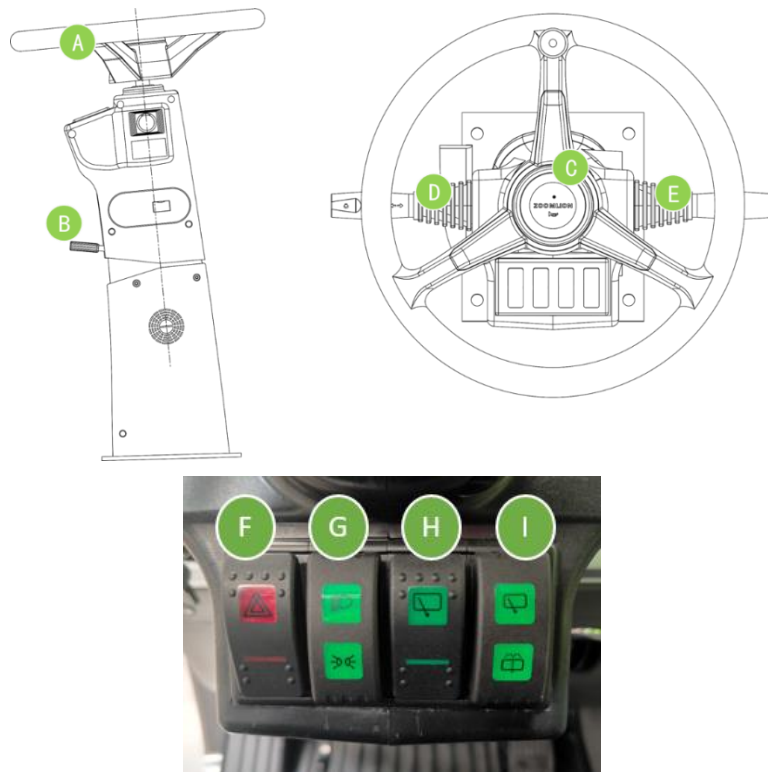

Figure 2-7 Direction machine and skip work switch

Table 2-4 Steering gear instruction

No.	Item	No.	Item
A	Steering wheel	F	Warn light switch
B	Steering gear joystick	G	Work light switch
C	Horn switch	H	Top wiper switch
D	Left switch group	I	Rear wiper switch
E	Right switch group		

- a) Steering wheel -- turn the front wheel counterclockwise to the left; Turn the front wheel clockwise to the right;
- b) Steering gear joystick -- Press down the adjusting handle to adjust the front and back position of the steering column. After adjustment, release the joystick to lock automatically;



**CAUTION :** It is strictly prohibited to adjust the steering column angle during driving, avoiding machine out of control resulting in serious accidents!

- c) Horn switch -Press the horn switch down and the horn honks; Release the switch and whistle stop.

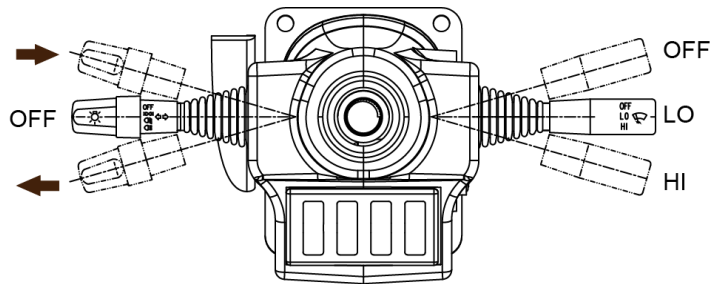

Figure 2-8 Left and right combined switch

- d) Left switch group – control driving light (4 gears: OFF- close, I – driving, II- dipped headlight, III – beam light). Push the switch forward, the right steering light ON; and push backward the left steering light ON;
- e) Right switch group - Control wind shield wiper (Three gear: OFF- close, LO- low speed, HI- high speed). Press the tail button of the switch to activate water sprayer.
- f) Warning light switch - control the work of dual flashing lights, after pressing the indicator light brightens, the left and right turn signals shine at the same time;
- g) Work light switch - press forward, the front light is on, press back, the front and rear lights are on at the same time;
- h) Top wiper switch - press to activate the top wiper
- i) Rear wiper switch - Press forward, the rear wiper starts to work, press back, the rear spray bottle starts to spray water.

### 2.2.10 Display

Driving interface



Figure 2-9 Driving interface







Table 2-5 Main interface instruction

No.	Item	No.	Item
a	Alarm indicators	d	Main interface options
b	Status indicators	e	Anti-tilting alarm
c	Work parameters		





















a) Alarm indicators

The fault or security status is red, and the warning status is yellow.

	Charging fault		Engine oil pressure low
	Parking brake		Coolant level low
	Gear not engaged		Fuel level low
	Air filter plug		Not fasten safety belt

	Hydraulic oil filter plug		Operator leaving seat
	Engine red warning light		Cab door not closed
	Engine yellow warn light		Speed limit warning

b) Status indicators

	Turn left		Turn right
	Low speed gear		High speed gear
	Front axle centring		Rear axle centring
	Front and Rear axle centring		Front wheel steering
	Crab steering		4WS
	Low beam		High beam
	Preheating		Cab mode
	Remote mode		Emergency mode
	Override mode		ECO mode
	Fan back blowing		XY axle moving

c) Work parameters



Figure 2-10 Driving parameters

Table 2-6 Driving parameters instructions

No.	Item	No.	Item
A	Engine Speed	E	Fuel level
B	Driving speed	F	Hydraulic oil temperature
C	Gear mode	G	Engine water temperature
D	Driving total distance		

**CAUTION**

When the engine water temperature or hydraulic oil temperature reaches the red zone, the equipment is in a dangerous working state, and the engine should be turned off immediately!

d) Main interface options



Figure 2-11 Main interface options

Table 2-7 Main interface options

No.	Item	No.	Item
A	Driving main interface	E	Media interface
B	Working main interface	F	Air condition setting interface
C	Parameters setting interface	H	Setting interface
D	Fault indicating interface		

**! CAUTION**

**CAUTION :** When the icon of the fault indicator screen turns red, a fault occurs. You need to enter the fault indicator interface for troubleshooting!

- e) Tilting alarm area



**Figure 2-12 Tilting alarm area**

- A-B: The reservation has a large degree of longitudinal stability.
- C-D: The telehandler is approaching the longitudinal stability limit and should be driven carefully.
- E The telehandler is very close to the longitudinal stability limit. An alarm will sound and there will be a quick intermittent sound. Drive with extreme caution. All arm movements can only be done in quick motion.
- F: Telehandler is at the recognized limits of longitudinal stability. A continuous alarm will sound at this point. The display flashes a tip icon, and all "dangerous" hydraulic movements are cut off. Before cutting, the hydraulic motion automatically slows down. Only hydraulic movements that increase stability should be performed.

**! CAUTION**

**When the red warning light is on, do not extend or lower the boom!**

### Main working interface



Figure 2-13 Operating interface

Table 2-8 Work interface icons

No.	Item	No.	Item
a	Slope requirement	j	Joystick lock button
b	Current accessory type	k	Click-to-retract button
c	Outrigger status indicator	l	Position memory select button
d	Joystick lock indicator	m	Boom fully retract indicator
e	Click-to-retract indicator	n	Float lock indicator
f	Accessory model	o	Upper part moving speed
g	Current max allowable load	p	Position memory select button
h	RFID indicator	q	Position memory select button
i	Accessory select	r	Position memory return button

- a) Max slope <math>< 3^\circ</math> when working
- b) Current accessory icon
- c) After the outrigger fully extends, the icon ON
- d) After clicking the controller lock button, the icon will light up, indicating that the controller output is cut off

- e) After pressing click-to-retract button, the icon will light up, and the icon will turn gray after retracting
- f) Current accessory parameters
- g) The maximum load under the current working condition, which changes with the change of boom angle
- h) Optional RFID and the communication is normal, the green indicator is ON, the communication is abnormal, red indicator is ON. If the RFID is not equipped, there is no indicator displayed
- i) Not equipped RFID, according to the actual equipment, manually configure the type of equipment;
- j) Joystick lock button
- k) Click-to-retract button
- l) Front and rear light indicator
- m) Boom fully retracted, green light ON; not fully retracted, the red light ON
- n) Rear axle floating, indicator in gray; rear axle locked, indicator in green
- o) Upper part moving speed switch area, set the moving speed in advance
- p) Click to show current position info
- q) Keep current position info
- r) Back to memory position

Main parameters interface



Figure 2-14 Parameters setting interface

- a) Customize the design parameters of the upper part moving speed. "100" means that the action runs in the maximum set current, and "0" means that the action runs in the set turtle speed current. Note that after setting a new speed, it needs to be saved to take effect;
- b) Anti-tip calibration interface. When anti-tip calibration needs to be performed again, move the device to the icon position and click calibration. After successful calibration, the indicator will turn green, and then calibrate according to the arrow sequence.

### Fault and input/output monitoring

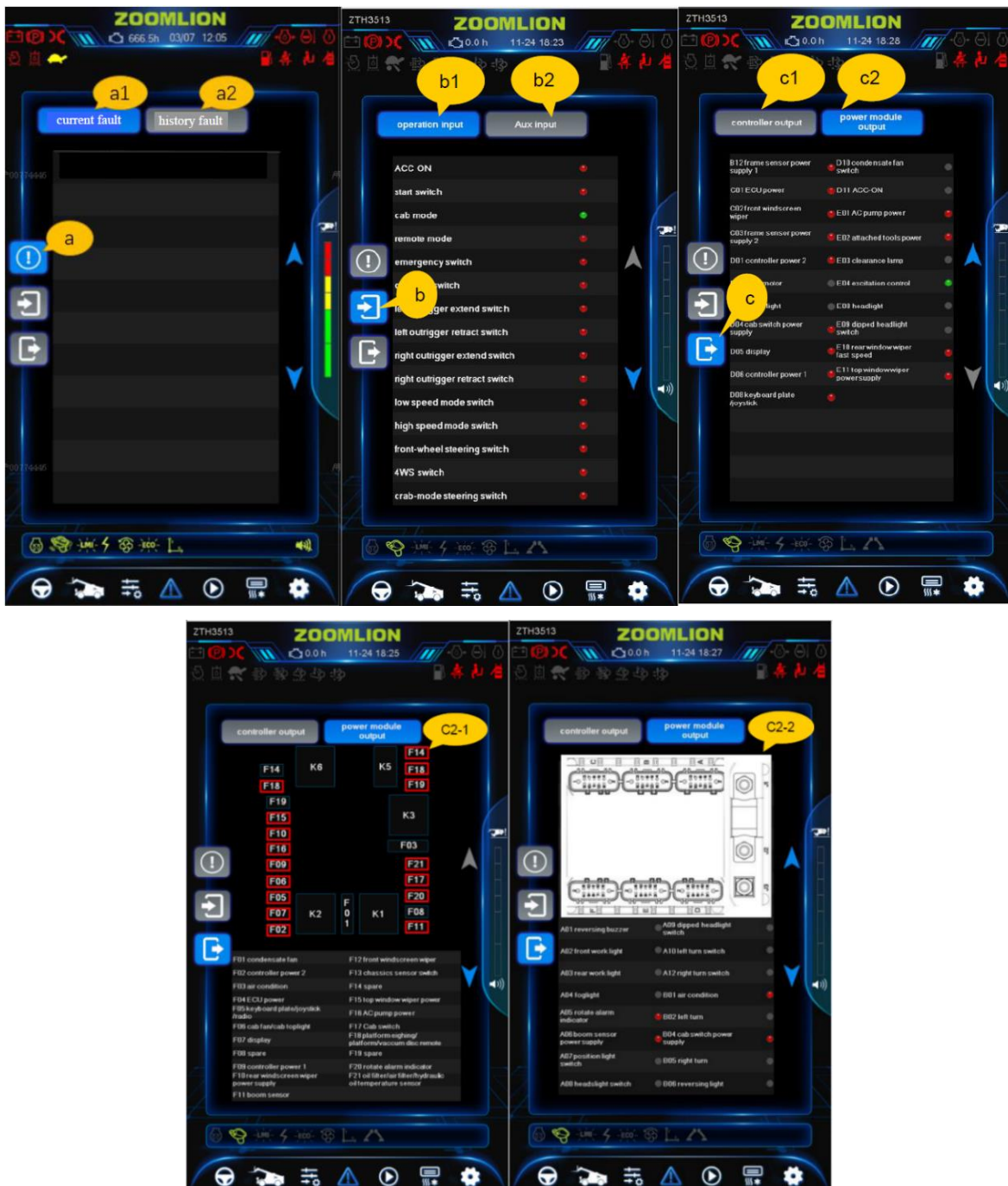

Figure 2-15 Fault monitoring interface

Fault monitoring interface – three categories:

- a) Fault info interface: “a1” current fault and “a2” history fault
- b) Input monitoring interface: “b1” operation input and “b2” auxiliary input
- c) Output monitoring interface, “c1” controller output and “c2” power module output;

“C2-1” power module fuse monitoring, normal status in gray, and abnormal status in red; “C2-2” power module input and output monitoring.



**CAUTION :** If the safety frame turns red on the output interface of the power module, it indicates that the fuse is burned off. Check immediately!

**Table 2-9 C2 power management output**

Item	Status	Item	Status
Reversing buzzer	Green light on (gray, green and red)	ECU power	Green light on (green and red)
Front work light	Green light on (gray, green and red)	Front wiper	Green light on (green and red)
Rear work light	Green light on (gray, green and red)	Frame sensor power supply 2	Green light on (green and red)
Fog light	Green light on (gray, green and red)	Controller power 2	Green light on (green and red)
Rotating alarm light	Green light on (green and red)	Start motor activate	Green light on (green and red)
Boom sensor power supply	Green light on (green and red)	Brake light	Green light on (gray, green and red)
Position light switch	Green light on (green and red)	Fan/dome light	Green light on (green and red)
High beam	Green light on (green and red)	Display	Green light on (green and red)
Low beam	Green light on (green and red)	Controller power 1	Green light on (green and red)
Turn left	Green light on (green and red)	Button panel/joystick	Green light on (green and red)
Turn right	Green light on (green and red)	Condensate fan switch	Green light on (green and red)
Air condition	Green light on (green and red)	ACC ON	Green light on (green and red)
Turn left	Green light on (gray, green and red)	AC Pump power	Green light on (green and red)
Cab switch power supply	Green light on (green and red)	Accessory power	Green light on (green and red)

MACHINE COMPONENTS AND CONTROLS

Turn right	Green light on (gray, green and red)	Position light	Green light on (gray, green and red)
Reversing light	Green light on (gray, green and red)	Excitation control	Green light on (gray, green and red)
Frame sensor power supply 1	Green light on (green and red)	High beam	Green light on (gray, green and red)



**CAUTION :** power management module output indicators have three colors, and red light indicates fault.

### Fault and input/output monitoring

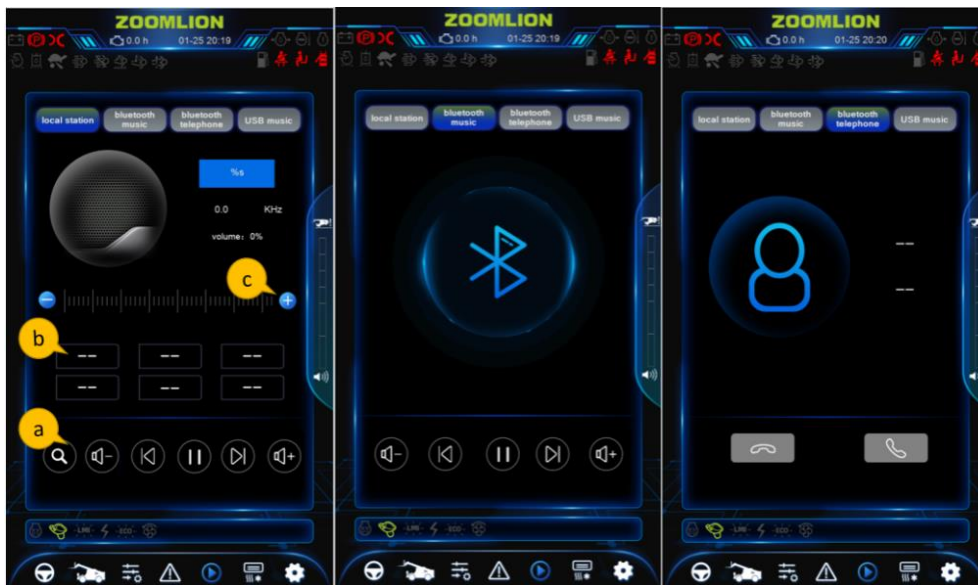

**Figure 2-16 Media interface**

Four categories in media interface: Radio, Bluetooth music, Bluetooth phone, and manuals.

- a) Search channel
- b) Click to mark radio, click again to cancel the mark
- c) Change channel

## Air condition



Figure 2-17 Air condition interface

- a) Air condition ON
- b) Inner recycle module ON
- c) Compressor starts, turn on the switch when cooling
- d) Temperature down
- e) Temperature up
- f) Blowing diagram
- g) Airflow rate down
- h) Airflow rate up

### Setting

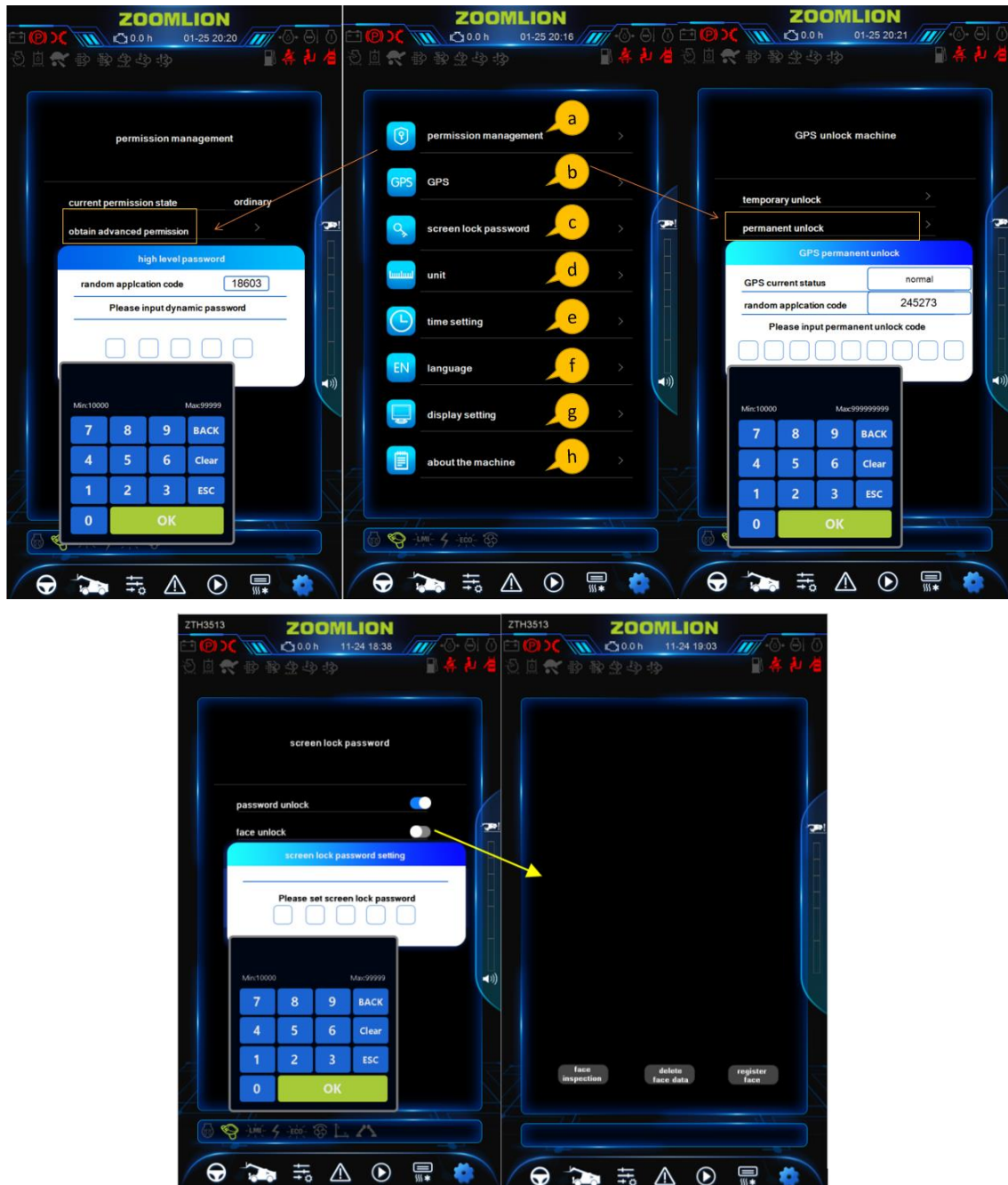

**Figure 2-18 Setting interface**

- a) Permission management, input password to enter the interface and have high level access.
- b) GPS unlock interface (if equipped), enter the subpage to lock temporary or permanently.
- c) Screen lock password interface, 5-digit password or face identification. Set 5-digit password before face identification setting, then click to record face identification.
- d) Unit switch, use metric unit as default.
- e) Time setting, set the current time.
- f) Language setting, use Simplified Chinese as default, Russian and English as option.

- g) Display setting, set the screen brightness at day and night.
- h) Machine info, check display program version, controller program version, machine code, and etc.

### 2.2.11 Gradienter

Used to observe the left and right horizontal state of the vehicle.



Before lifting the boom, ensure that the bubble of the level must be at the "0" scale, otherwise there is a risk of tipping!

### 2.2.12 Rear window

In case of sudden emergency, the rear window lock can be used for emergency escape window by turning counterclockwise.

## 2.3 Power management module

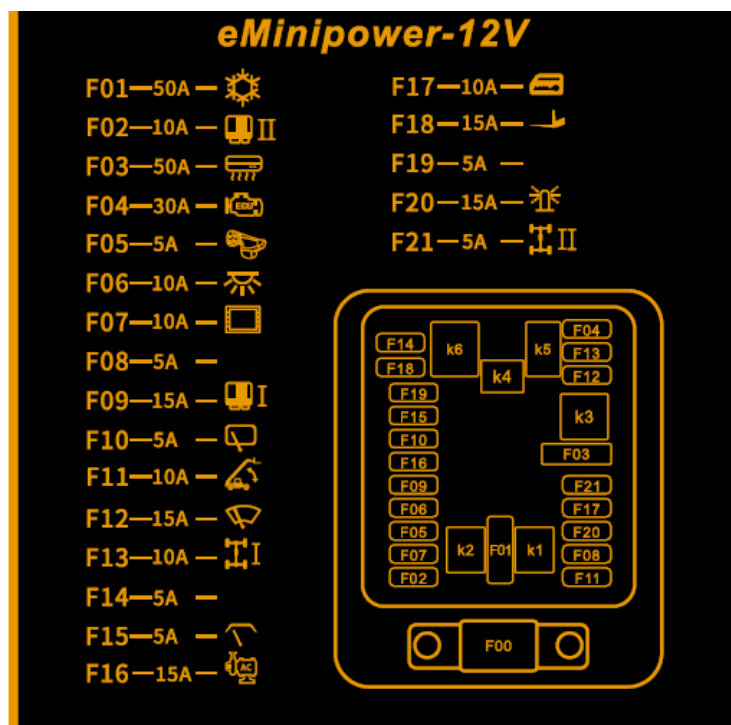
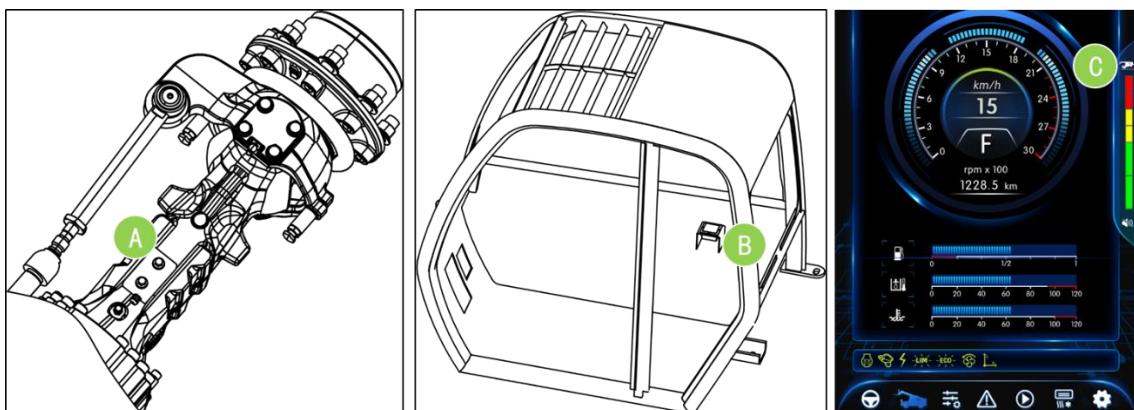

Figure 2-19 Power management module

**Table 2-10 Power management module function instruction**

Fuse	Item	Max output current	Note
F01	Condenser	50A	
F02	Controller power 2	10A	
F03	Air condition	50A	
F04	ECU power	30A	
F05	Button panel/joystick	5A	
F06	Cab inner fan/cab dome light	10A	
F07	Display	10A	
F08	Reserve		
F09	Controller power 1	15A	
F10	Rear window wiper fast	5A	
F11	Boom sensor power supply	10A	
F12	Front wiper	15A	
F13	Frame sensor power supply 2	10A	
F14	Reserve	5A	
F15	Top window wiper power supply	5A	
F16	AC Pump power	15A	
F17	Cab switch power supply	10A	
F18	Accessory power	15A	
F19	Reversing light	5A	
F20	Rotating alarm light	15A	
F21	Frame sensor power supply 1	5A	

### 2.4 Anti-tilting system



**Figure 2-20 Anti-tilting system**

Table 2-11 Anti-tilting system function

No.	Item	No.	Item
A	Force sensor	C	Anti-tilting alarm
B	Anti-tilting system device		

**⚠ DANGER**

It is forbidden to adjust or disassemble the force sensor and must be carried out by professionally trained personnel.

**⚠ DANGER**

When the anti-tilting warn light is in yellow, please be careful to operate, there is a risk of rollover. When the red light is on, the dangerous direction action will be cut off.

### 2.5 Front headlight



Figure 2-21 Front headlight

Table 2-12 Front headlight instruction

No.	Item	No.	Item
A	LF light indicator	E	RF headlight indicator
B	LF headlight low beam	F	RF headlight low beam
C	LF headlight high beam	G	RF headlight high beam
D	Left turning indicator	H	Right turning indicator

### 2.6 Tail light

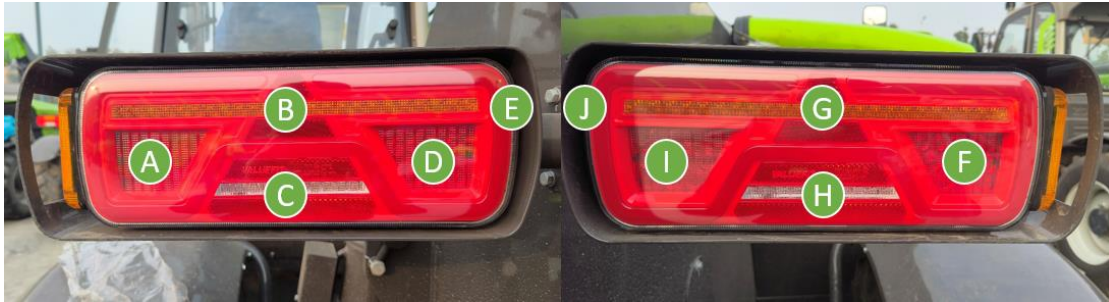

Figure 2-22 Tail light

Table 2-13 Tail light instruction

No.	Item	No.	Item
A	Left brake light	F	Right brake light
B	Left turn light	G	Turn right 向灯
C	Left reversing light	H	Right reversing light
D	Left fog light	I	Right fog light
E	Left position light	J	Right position light

### 2.7 Rotation alarm light

The rotating warning light is located above the cab, and the engine starts to rotate the warning light.



Figure 2-23 Rotation alarm light

### 2.8 Boom support

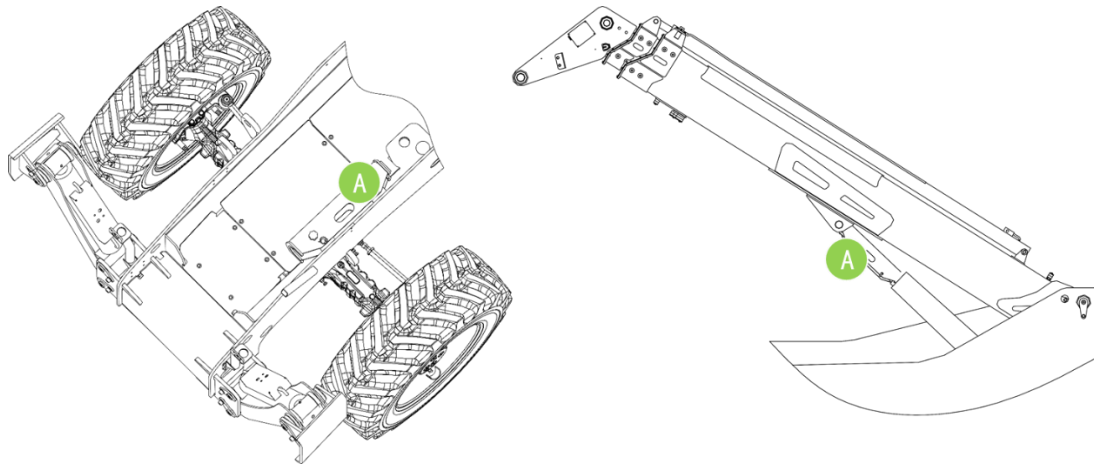

Figure 2-24 Boom support

**⚠ CAUTION**

The boom support must be used when performing under-boom maintenance, otherwise there is a risk of operation.

### 2.9 Remote (if equipped)

**⚠ CAUTION**

Before using the remote, you need to switch the mode selection switch to the remote control mode.



Figure 2-25 Remote control panel

**Table 2-14 Remote panel instruction**

No.	Item	No.	Item
A	Fault indicating	I	Reserved three-gear self-locking switch
B	Status indicating	J	Enable two-gear self-resetting switch
C	Antenna	K	Rotating speed two-gear self-locking switch
D	Reserve three gears self-resetting switch	L	Emergency two-gear self-resetting switch
E	Boom extension joystick	M	Engine start-stop three-gear self-resetting switch
F	Boom lifting joystick	N	Accessory leveling three-gear self-resetting switch
G	Turntable rotating joystick	O	Remote start switch
H	Platform rotation three-gear self-resetting switch	P	Horn switch

- a) Four status of fault indicator: When the green light blinks 1 second, it indicates that the transmitter works normally; when the red light blinks 1 second, accompanied by the buzzer sound, it indicates that the battery voltage of the transmitter is insufficient; when the red and green light blinks alternately, it indicates that the intelligent key of the remote control is not recognized; when the red and green lights are steady on, it indicates that the high-frequency module of the remote control is not recognized;
- b) Two status of Status indicator: Green On indicates working status, and Green flashing indicates system fault;
- c) Boom extension handle swing upward, boom extends, downward for retracting; the larger the swing amplitude, the faster the extension speed;
- d) Boom lifting handle swing upward, boom up, downward for lowering; the larger the swing amplitude, the faster the extension speed;
- e) Turntable rotating handle swing upward for turntable left-turn, and downward for right-turn; the larger the swing amplitude, the faster the extension speed;
- f) Platform swing switch up, platform turns left, down for platform right turn;
- g) The enable switch is used with the action switch to perform any remote control action (except emergency function), it is necessary to flip down and hold the enable switch;
- h) The speed switch provides two kinds of engine speed options: flip down to Turtle gear at 1600rpm, and flip up to Rabbit gear at 2200rpm;
- i) Flip down the emergency switch to activate the emergency power function. When the engine is not

started, the emergency switch can be executed with any remote control action;

### **⚠ CAUTION**

The emergency system uses the power that is used to start the battery, and please control the service time within 10 minutes.

- j) Toggle the engine start-stop switch upwards to start the engine, toggle down to stop the engine;
- k) Toggle the accessory leveling switch upwards to flip upward, toggle down to flip downward;
- l) The emergency stop switch is located below the start switch of the remote control on the right side, press the emergency stop switch, disconnect the power of the remote control and all the actions being performed by the remote control;
- m) The remote control start switch is used to start the remote control after the emergency stop switch is pulled up;
- n) The horn switch can turn on the horn to warn the surrounding.

## 2.10 Hydraulic fast changing plug (option)

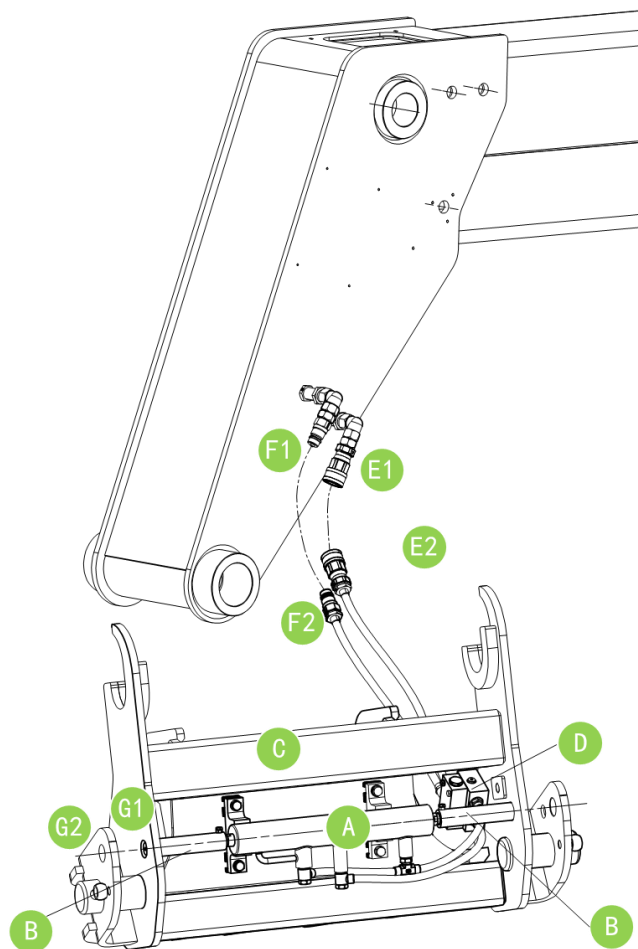

Figure 2-26 Hydraulic accessory plug

**Table 2-15 Hydraulic accessory plug instruction**

No.	Item	No.	Item
A	Hydraulic cylinder	E1, E2	Fast changing connector
B	Plug pin	F1, F2	Fast changing connector
C	Connecting device body	G1, G2	Plug hole
D	Cylinder balance valve		

 **CAUTION**

To operate the hydraulic quick change latch, it is necessary to connect the head pipe of the boom in advance, and operate the front roller of the multi-function handle for control.

# **ZOOMLION**

## **Telehandler Operation Manual**

### **Section 3 MACHINE INSPECTION**

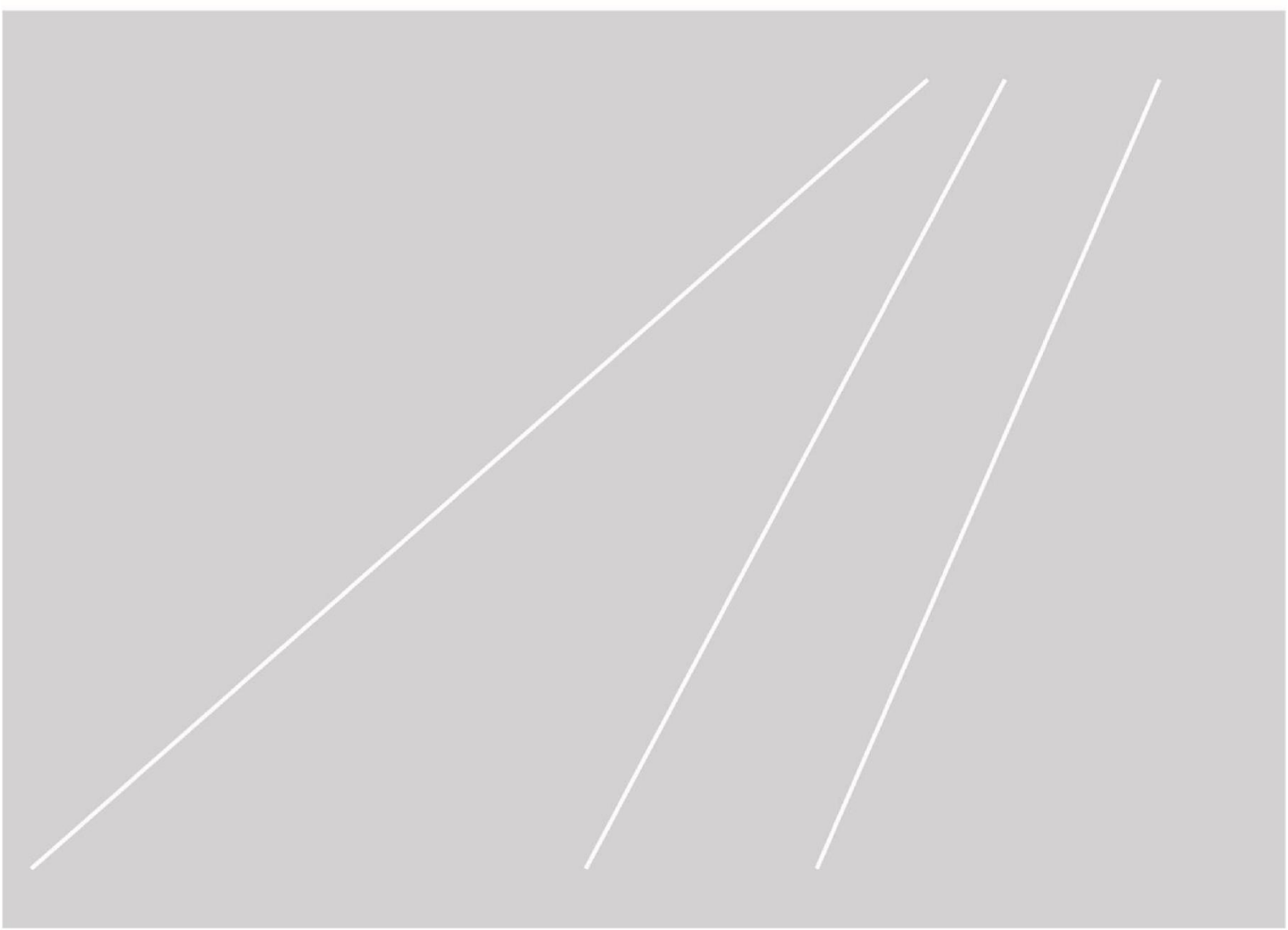



## SECTION 3 MACHINE INSPECTION

### 3.1 General



**An operator must not operate the machine, only if:**

**He has learned and practiced the principles of safe machine operation contained in this operational manual;**

- a) Only use the machine as it was intended.
- b) Know and understand the pre-operation inspection before going on to the next section.
- c) Implement functional test before operating the machine at all times;
- d) Inspect job site;

#### 3.1.1 Pre-Start Inspection Principle

- a) It is the responsibility of the operator to perform a pre-operation inspection and routine maintenance.
- b) The pre-operation inspection is a visual inspection performed by the operator prior to each work shift. The inspection is designed to discover if anything is apparently wrong with a machine before the operator performs the function tests.
- c) The pre-operation inspection also serves to determine if routine maintenance procedures are required. Only routine maintenance items specified in this manual shall be performed by the operator.
- d) Refer to the list on the next page and check each of the items.
- e) If damage or any unauthorized variation from factory delivered condition is discovered, the machine must be tagged and removed from service.
- f) A malfunctioning machine must never be used. If malfunctions are discovered, the machine must be tagged and removed from service.
- g) After repairs are completed, the operator must perform a pre-operation inspection again before putting the machine into service. A malfunctioning machine must never be used.

#### 3.1.2 Pre-Start Inspection

- a) Be sure operator's, safety, and responsibilities manuals are complete, legible, and in the storage container located on the machine.
- b) Be sure all decals are in place and legible. See Inspections section.
- c) Check for hydraulic oil leaks and proper oil level. Add oil if needed. See Inspections section.
- d) Check for engine oil leaks and proper oil level. Add oil if needed. See Inspections section.
- e) Check for engine coolant leak and proper coolant level. Add coolant if needed. See Inspections section.

- f) Check the following components or areas for damage, improperly installed, or missing parts and unauthorized modifications:
  - 1) Electrical components, wiring, and electrical cables.
  - 2) Hydraulic hoses, fittings, cylinders, and manifolds.
  - 3) Fuel and hydraulic tank.
- g) Driving axle and rim
- h) Engine and relevant components
- i) Air condition system (if equipped)
- j) Wiper and water spray bottle
- k) Limit switch and horn
- l) Work light, alarm and indicator (if equipped)
- m) Ensure that the battery is correctly connected
- n) Nut, bolt and other fasten components
- o) Check the machine for:
  - 1) Cracks in welds or structural components.
  - 2) Dents or damage to machine.
  - 3) Excessive rust, corrosion or oxidation.
- p) Proper tire pressure
- q) Adjust rear review mirror for clear view
- r) Be sure that all structural and other critical components are present and all associated fasteners and pins are in place and properly tightened.
- s) After inspection, be sure that all covers are in place and latched.

### 3.1.3 Machine starting inspection

- a) Check display indicator for:
  - Alarms or faults;
  - Engine coolant temperature table. Preheating engine, the pointer of the instrument should point to the green area between 70 ° C and 95 ° C.
- b) Check if the generator is working.
- c) Check if the parking brake is released.



**When the oil pressure warning indicator lights up, stop the engine immediately.**



**If the fault alarm lights up, it is very dangerous to drive, and the machine must be stopped immediately for inspection and repair. Work light**

## 3.2 Workplace Inspection



**An operator must not operate the machine, only if:**

**He has learned and practiced the principles of safe machine operation contained in this operational manual;**

- a) Avoid hazardous situations;
- b) Perform a pre-operation inspection at all times;
- c) Implement functional test before operating the machine at all times;
- d) Inspect job site;

Know and understand the pre-operation inspection before going on to the next section.

Only use the machine as it was intended.

### 3.2.1 Workplace inspection principle

The workplace inspection helps the operator determine if the workplace is suitable for safe machine operation. It should be performed by the operator prior to moving the machine to the workplace.

It is the operator's responsibility to read and remember the workplace hazards, then watch for and avoid them while moving, setting up, and operating the machine.

## 3.2 Workplace Inspection

Be aware of and avoid the following hazardous situations:

- a) Drop-offs or holes.
- b) Bumps, floor obstructions, or debris.
- c) Sloped surfaces.
- d) Unstable or slippery surfaces.
- e) Overhead obstructions and high voltage conductors.
- f) Hazardous locations.
- g) Inadequate surface support to withstand all load forces imposed by the machine.
- h) Wind and weather conditions.
- i) The presence of unauthorized personnel.
- j) Other possible unsafe condition.

### 3.3 Decal Inspection

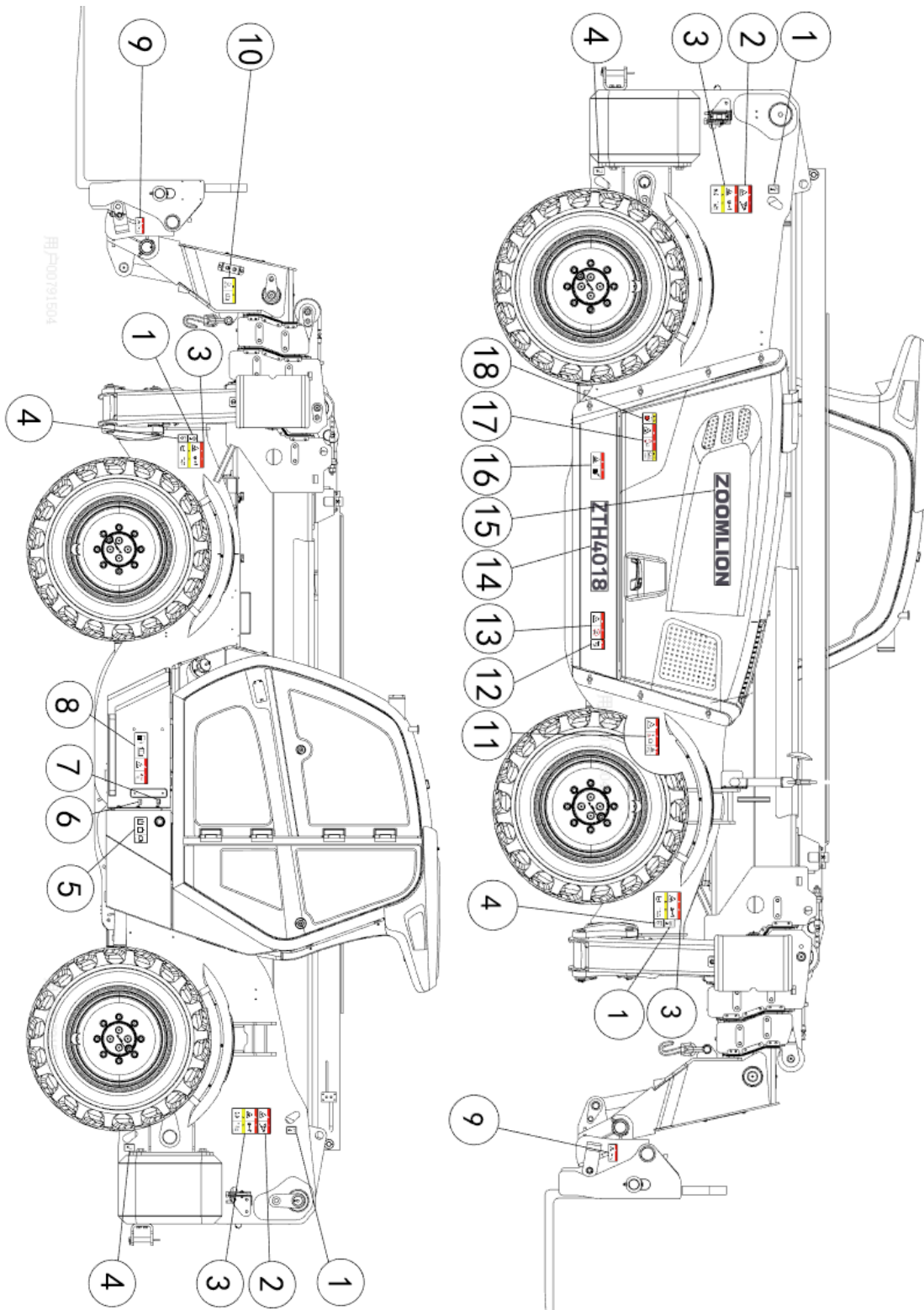

Figure 3-1 Decal position

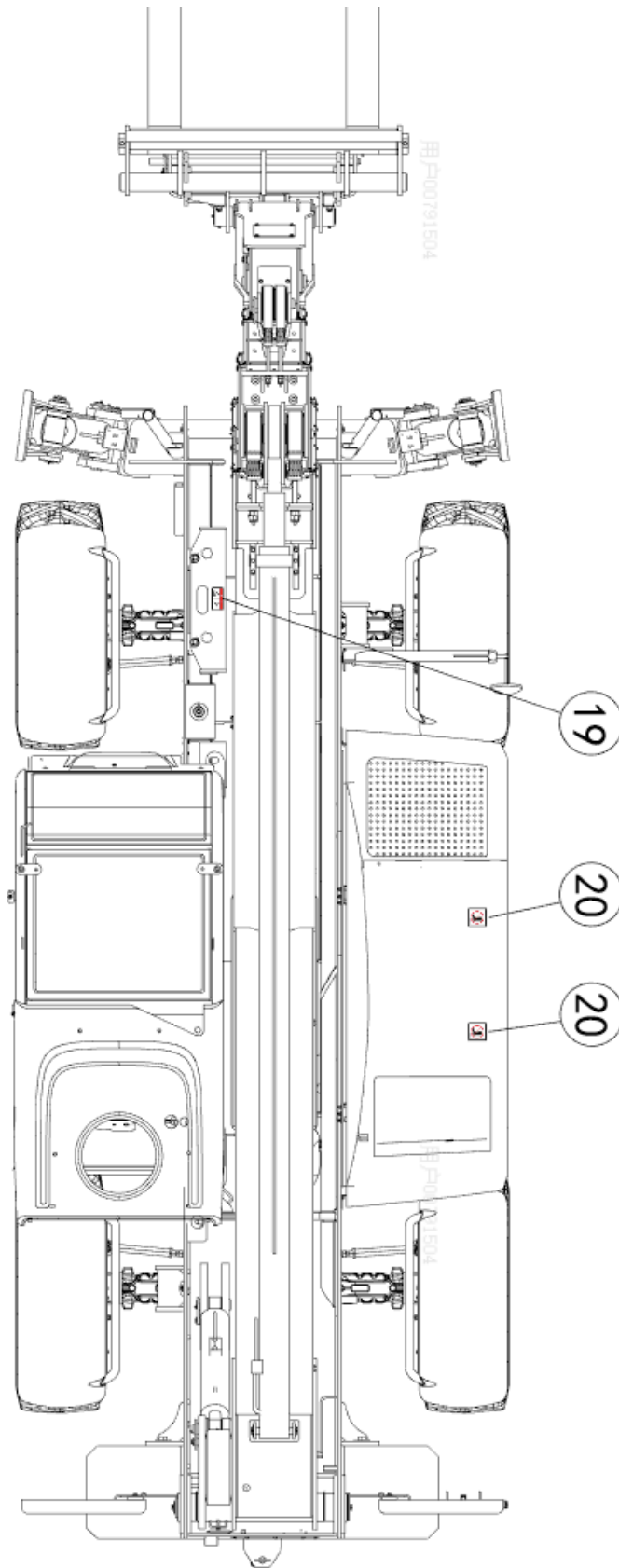

Figure 3-1 Decal position (cont.)

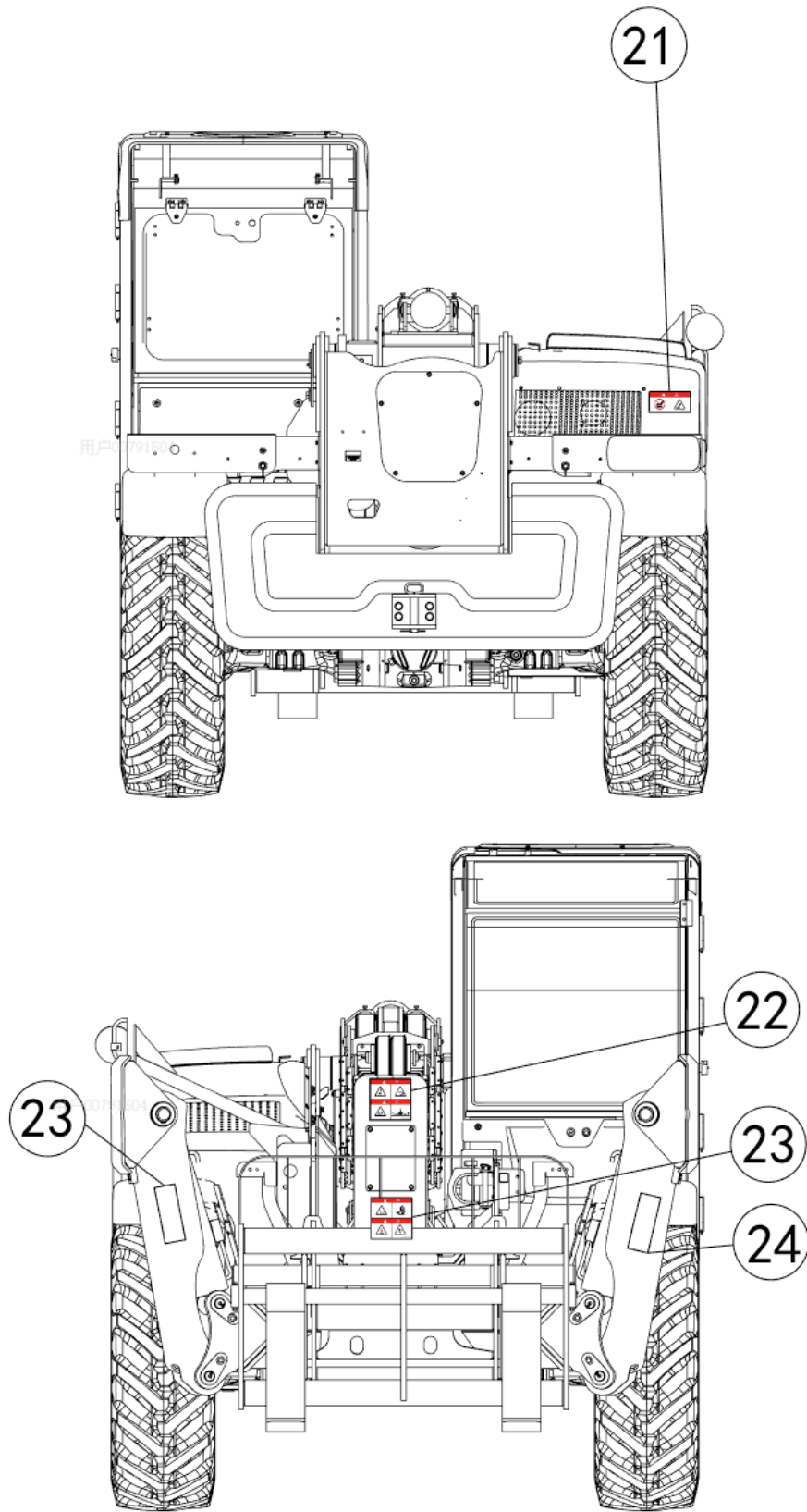

Figure 3-1 Decal position (cont.)

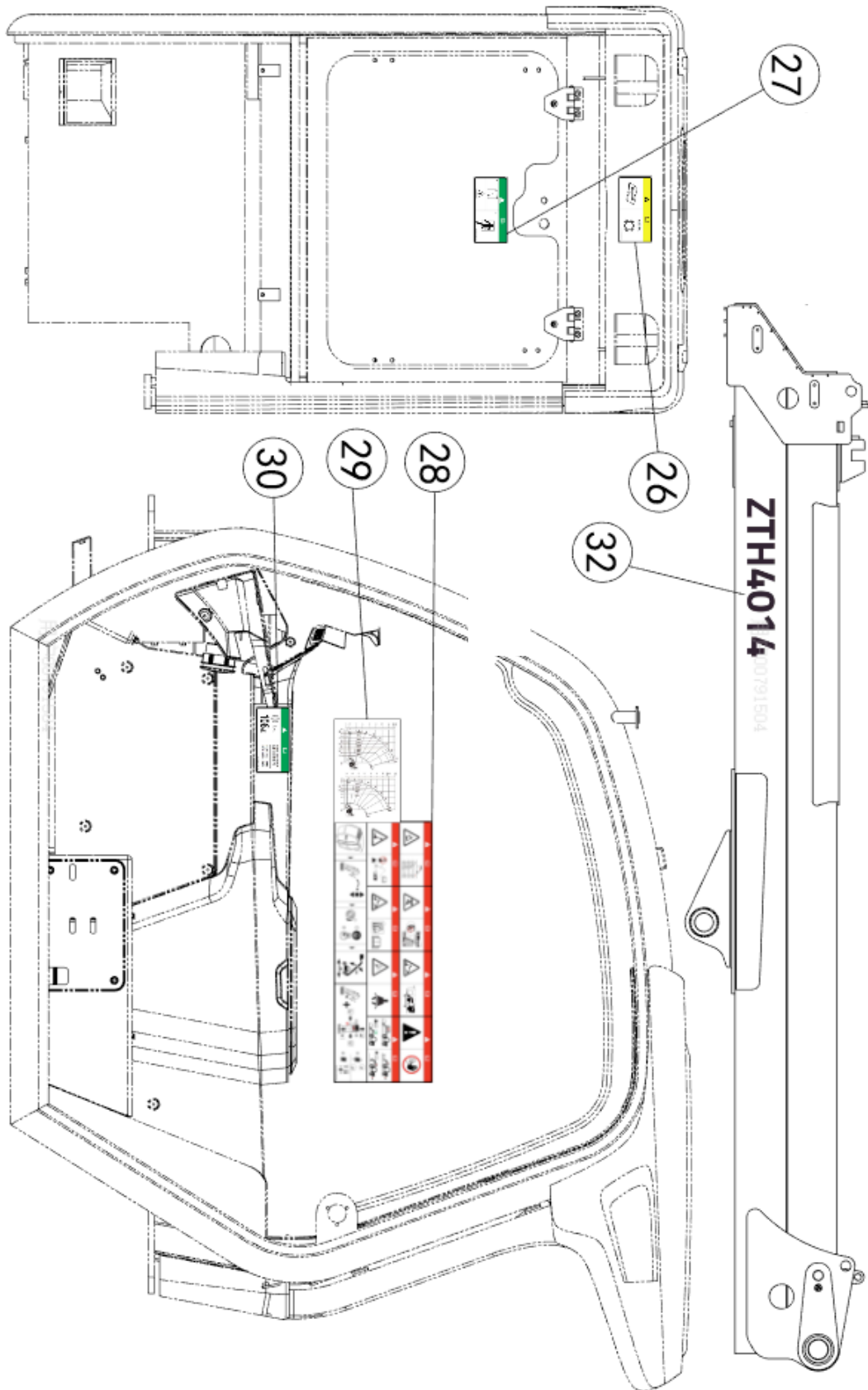

Figure 3-1 Decal position (cont.)

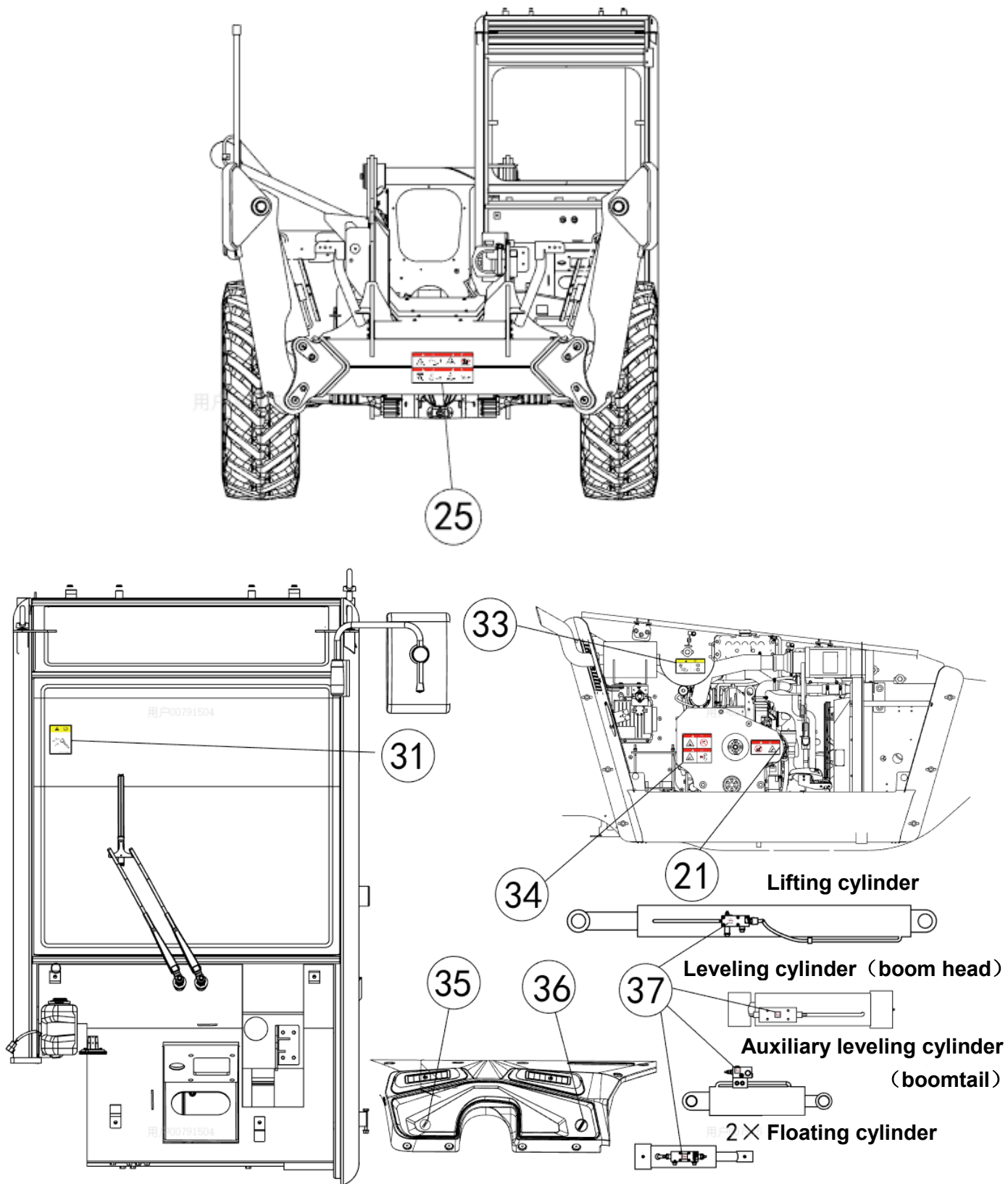

Figure 3-1 Decal position (cont.)

Use the pictures on next page to verify that all decals are legible and in place.

Below is a numerical list with quantities and descriptions.

**Figure 3-1 Decal position**

Codes are corresponded to the decal (not all decal are pasted on the machine)





No.	Code/Description	Qty	Decal
1	02151607010221300	4	
	Lifting label		
2	02150807010231020	2	
	Spraying hazard- use card to check leak		
3	02151607010221150	4	
	Crushing hazard and tire pressure label		
4	02151607010221290	4	
	Tie down point Label		
5	02151607010221181	1	
	Hydraulic tank - add fuel as required		
6	02151607010221370	1	
	Low oil level (right)		

Table 3-1 Decal (cont.)



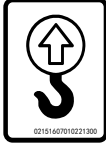

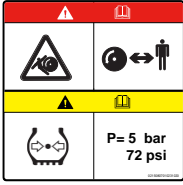
No.	Code/Description	Qty	Decal
7	02151607010221360	1	
	High oil level (right)		
8	02151607010221030	1	
	Fuel tank and explosion hazard label		
9	02151607010221140	2	
	Crushing hazard - away from moving parts		
10	02151607010221200	1	
	Hydraulic fast connector guide		
11	02151607010221110	1	
	Battery hazard label		
12	02151607010221170	1	
	Hand cutting hazard - away from rotating fan		
13	02151607010221130	1	
	Burn hazard - Do not loose cap before cooling		

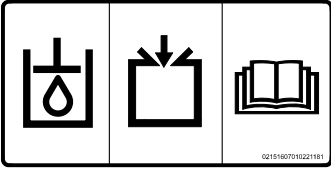
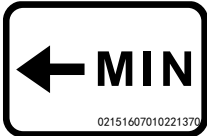
Table 3-1 Decal (cont.)



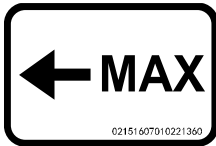
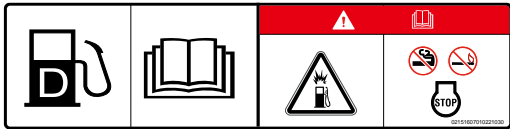

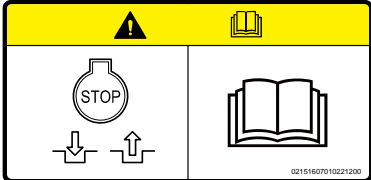
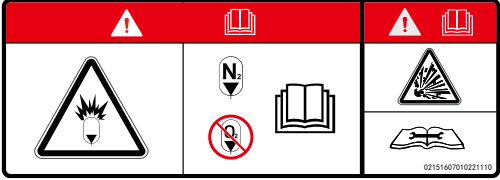
No.	Code/Description	Qty	Decal
14	02150817010231010	1	<b>ZTH4014</b>
	ZOOMLION label (524×100)		
15	02151607010221260	1	<b>ZOOMLION</b>
	ZOOMLION label -90		
16	02151607010221450	1	
	Smashing hazard		
17	02151607010221070	1	
	Battery explosion and power disconnecting label		
18	02151607010221320	1	
	Main power switch		
19	02151607010221160	1	
	Crushing hazard - maintain support bracket (100×50)		
20	02151607010221310	2	
	No stepping		

Table 3-1 Decal (cont.)

No.	Code/Description	Qty	Decal
21	02151607010221120 Burn hard - away from hot surface	2	
22	02151607010221090 Machine overturning hazard label	1	
23	02151607010221010 Hazards label	1	
24	02150817010231040 Outrigger load and away from outrigger label	2	
25	02151607010221020 Safety risks label	1	
26	02151607010221210 Maintain air condition as manual	1	

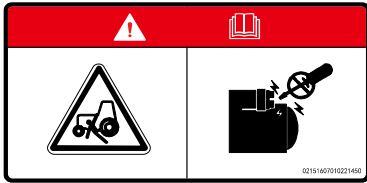
Table 3-1 Decal (cont.)

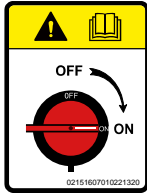
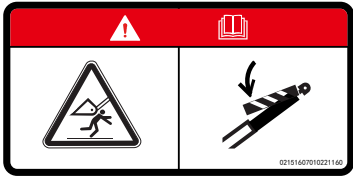



No.	Code/Description	Qty	Decal
27	02151607010221270 Emergency exit (transparent)	1	
28	02151607010221050 Cab operation instruction label (transparent)	1	
29	02150817010231020 ZTH4014 Fork working curve (transparent)	1	
30	02151607010221400 Noise and cab safety certificate (106dB)	1	
31	02151607010221280 Safe hammer knocking point (transparent)	1	
32	02150817010231060 ZTH4014 model label (786×150)	1	
33	02151607010221190 Air condition hot water valve switch	1	

Table 3-1 Decal (cont.)

No.	Code/Description	Qty	Decals
34	02151607010221060	1	
	Engine explosion and away from belt label		
35	02151607010221380	1	
	Override mode		
36	02151607010221390	1	
	Ignition switch		
37	02151607010221350	7	
	No disassembly (30×30)		

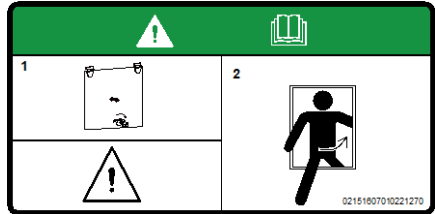
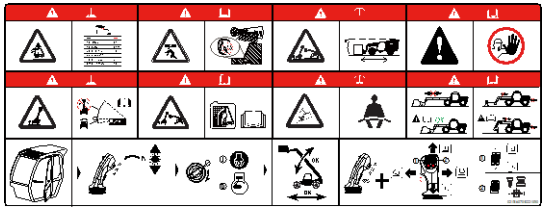
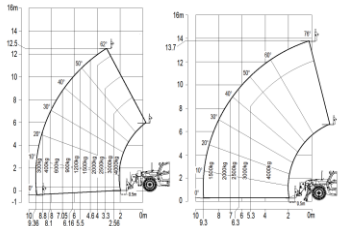
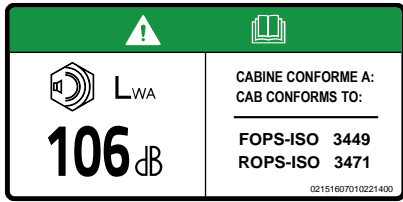
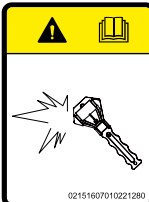
# **ZOOMLION**

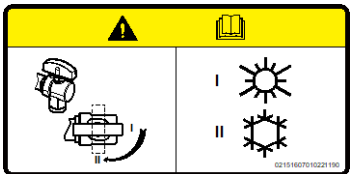
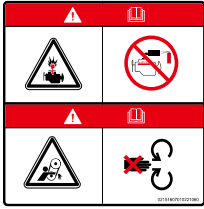
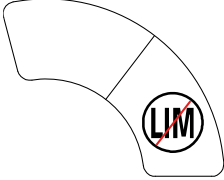
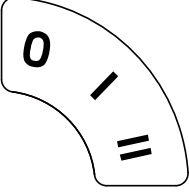
## **Telehandler Operation Manual**

### **Section 4 OPERATION INSTRUCTION**





## SECTION 4 OPERATION INSTRUCTION

### 4.1 General



**An operator must not operate the machine, only if:**

**He has learned and practiced the principles of safe machine operation contained in this operational manual;**

- a) Avoid hazardous situations;
- b) Perform a pre-operation inspection at all times;
- c) Implement functional test before operating the machine at all times;
- d) Inspect job site;
- e) Only use the machine as it was intended.

Fundamentals::

The Operating Instructions section provides instructions for each aspect of machine operation. It is the operator's responsibility to follow all the safety rules and instructions in the operator's, safety and responsibilities manuals.

Using the machine for anything other than lifting personnel, along with their tools and materials, to an aerial work site is unsafe and dangerous.

Trained and authorized personnel operate the machine only. If more than one operator is expected to use a machine at different times in the same work shift, they must all be qualified operators and are all expected to follow all safety rules and instructions in the operator's, safety and responsibilities manuals. That means every new operator should perform a pre-operation inspection, function tests, and a workplace inspection before using the machine.

### 4.2 Engine Operation



- a) When operating at high altitudes, machine performance may be impaired by reduced air density;
- b) When operating in areas with higher ambient temperatures, machine performance may weaken and engine coolant temperature may rise;
- c) The diesel engine must wait until the electric plug light is off before starting the engine;
- d) If an unexpected shutdown is caused by an engine failure, the fault must be removed before the engine can be started again;
- e) Please consult Zoomlion Service for machine operation under abnormal conditions.

#### 4.2.1 Start Engine

After the pre-start check is completed, start the engine. When the ambient temperature exceeds 0 ° C,

start the engine as follows:

- a) Turn the main power switch to ON
- b) Multifunction joystick FNR on “N” gear, accelerator, brake, multifunction handle and thumb handle are in natural status
- c) Cab closed
- d) Turn the ignition switch to I position
- e) Turn the ignition switch to III position and start engine

When the engine starts, release the ignition key immediately. During the starting process, if the engine is turned off, the engine should be restarted after it stops rotating.

After the engine starts, check whether the reading of each instrument is normal, if it is not normal, turn off the engine, and find out the reason.

Full throttle operation should be avoided before the engine reaches the normal operating temperature.



Diesel engines must wait until the electric plug light is off before starting the engine.



Before loading any goods, let the engine run at a low speed for a few minutes to warm up.



The machine cannot start the engine when it enters the emergency power state and non-cab mode.

### 4.2.2 Cold start

When the ambient temperature is lower than 10°C, the equipment needs to be preheated when starting .

- a) When the ambient temperature is lower than 10°C, after powered on, the engine will automatically open the glow plug for preheating, and the working time is about 8s. If it cannot be started within 8s, it can be powered on again 2 to 3 times. The relationship between the heating time of the glow plug and the temperature is shown in Table 4-1.

**Table 4-1 Glow plug heating time and temperature relationship**

Temperature	Preheating time
Higher than 10°C	No need
-5°C to 10°C	10s
-20°C to -5°C	10s

- b) After starting the engine, idle for 10 minutes before other operations.

## ⚠ WARNING

In the low temperature environment, if you cannot start, please contact Zoomlion service for a solution, do not start the engine frequently, so as to avoid irreversible damage to the engine.

Note: When the ambient temperature is lower than  $-20^{\circ}\text{C}$ , additional auxiliary starting equipment (such as electric heater) is required to start. If necessary, please contact Zoomlion Service or sales retrofit.

### 4.2.3 Fuel system exhaust

The fuel system needs to be vented in the following situations to start the engine:

- After disassembly or reassembly of the fuel filter and fuel pipe;
- After no oil is re-added in the fuel tank;
- Leave unused for a long time.

Exhaust operation:

- Add fuel to the fuel tank;
- Press the manual pump of the fuel filter to exhaust, the position of the manual pump is shown in the



figure below.

### 4.2.4 Spark extinguisher (optional)

The equipment equipped with the spark extinguisher generally works in inflammable and explosive places such as oil fields and gas stations. The switch of the spark extinguisher should be turned on before the

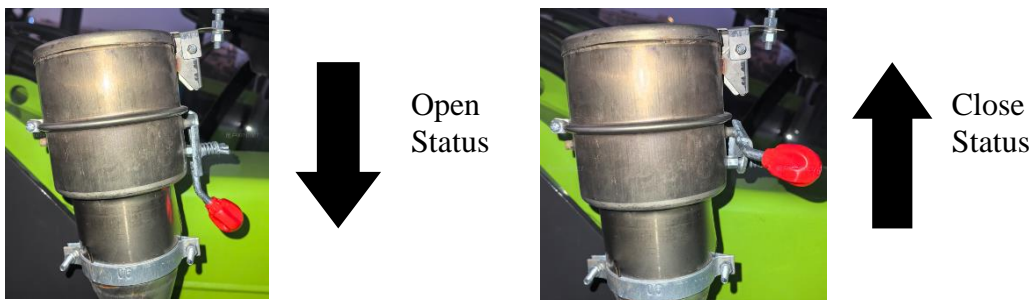

equipment enters, and the switch of the spark extinguisher should be turned off in time when the equipment exits the area.

- When the equipment is regenerated, the spark extinguisher switch should be turned off in a safe environment;

2) When the spark extinguisher is off, the maximum output power of the engine will be slightly reduced.

3) For long-term use, the use period of the spark extinguisher is one year, and it needs to be replaced after expiration; If it is only assembled when in use and dismantled when not in use, the use period of the spark extinguisher is 2 years, and it needs to be replaced after expiration.

#### 4.2.5 Heater (optional)

In some places where the ambient temperature is very low, the difficulty of starting the engine can be solved by equipping the heater, and the specific operation method of the heater is as follows:

Turn on the power 1-2 hours before the equipment is used to heat the engine oil, engine antifreeze, battery and hydraulic oil;

#### WARNING

**1 Before the power should check the oil level, to ensure that all the heating surface of the heater is immersed in the oil, can not bare dry burning;**

**2. In order to avoid scaling on the surface of the heater affecting the performance, it is recommended to maintain the heater once in two years or 2000 hours, and the maintenance must be carried out in the heater power off and cooling state, and the threaded connection part should be coated with thread sealant during installation;**

**3. During use, avoid the heater cable being pulled or squeezed. If the cable is damaged or cracked, contact the service personnel to replace it.**

**4. The surface of the battery heater should not be in contact with explosive or corrosive liquids.**

#### 4.2.6 Turn off the machine and park

- a) Drive the equipment to a protected area;
- b) Ensure that the main boom is fully recovered and lowered to the fork or accessory landing;
- c) Unload all goods before stopping operation, and run the engine at idle speed for 3-5 minutes, so that the engine gradually cools down before extinguishing;
- d) Turn the ignition key switch counterclockwise to the "O" position, shut down the engine, and remove the key;
- e) Close and lock all hoods and doors;
- f) If parking for a long time, it is recommended to turn off the main power switch.

#### CAUTION

**In normal operation, the main switch of the power supply can not be turned off.**

#### NOTICE

**This cooling period is crucial for turbocharged engines, which generate more heat than other engines when they operate. Check the Engine Operation and Maintenance manual for more information.**

## 4.3 Driving operation

### 4.3.1 Machine start

After the pre-start preparation is completed, the vehicle can be started by following the following steps:

- a) Press the brake pedal
- b) Release the parking brake
- c) Set the FNR key of the multifunction handle in the "F" or "R" position;
- d) Slowly release the brake pedal while slowly pressing the accelerator pedal to move the machine.

#### CAUTION

Only the first drive after the engine has started requires the release of the parking brake.

#### CAUTION

During driving, the cooling water temperature should be kept between 70 ° C and 95 ° C, and the cooling water temperature is too low or too high, which will reduce the performance of the engine.

#### CAUTION

Often check the tire pressure to ensure that normal tire pressure driving, low tire pressure will aggravate tire wear, while increasing fuel consumption.

#### CAUTION

Please fasten your seat belt for long distances drive!

### 4.3.2 Park

- g) Gently press the brake pedal to slow down the machine, and press the brake pedal at low speed to completely stop the machine in the specified position;
- h) Put the machine in N gear
- i) Run the engine idle for at least 3-5 minutes after parking and then turn off the engine to achieve gradual cooling;
- j) Turn off the engine and continue to power on the engine for about 30 seconds to enable the engine ECU to save engine operation data; then turn the key switch back to the "O" position and pull it out.

#### CAUTION

If the main power switch turns on state for a long time after parking, the battery power is consumed or the circuit fault will be caused.

- k) When parking the machine on slope to prevent accidents, it is necessary to add a block at the front and back of the wheel;
- l) When parking the machine on the road at night, warning lights should be lit to prevent collision accidents.

### 4.3.3 Driving on slope

- a) Empty load: fork or accessories downward
- b) Loaded: fork or accessories upward

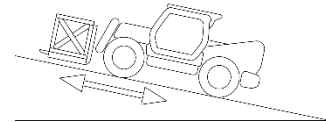
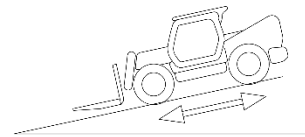

### 4.4 Outrigger retract

The use of outriggers can improve the operational performance of the machine.

- a) Operate the left and right thumb handles to lower the two outriggers on the ground and lift the two front wheels completely off the ground;
- b) Observe the cab level and adjust the left and right outriggers to ensure that the bubbles of the level must be on the "0" scale

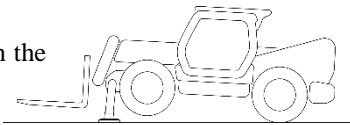

**⚠ DANGER**

**Before lifting the boom, ensure that the bubble of the level must be at the "0" scale, otherwise there is a risk of tipping!**

- c) After operation, slowly raise the outrigger after fully retracting the boom.

**⚠ CAUTION**

**CAUTION : Raise the outrigger only when the main boom has fully retracted and the boom angle is less than 50°.**

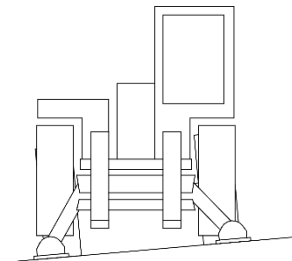

**⚠ CAUTION**

**Note: No driving after either outrigger is on the ground.**

### 4.5 Frame leveling (if equipped)

- a) Place the gear in "N" position when it is close to the place where the goods are placed or lifted;
- b) Observe the cab level. When working on a lateral slope, adjust the machine to ensure that the bubble of the level must be at the "0" scale.

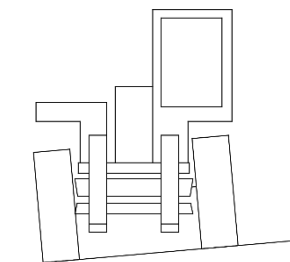

**⚠ DANGER**

Before lifting the boom, ensure that the bubble of the level must be at the "0" scale, otherwise there is a risk of tipping!

**⚠ CAUTION**

CAUTION : Frame tilt can be adjusted only if the boom angle is less than 30°.

**4.6 Move goods**

When handling the goods, it is necessary to know the weight of the goods, the center of the goods, and the moving distance and height. Refer to the rated load chart to confirm whether the handling is feasible. If the machine has more than one load chart, ensure that the reference load chart corresponds to the attachment on the machine.

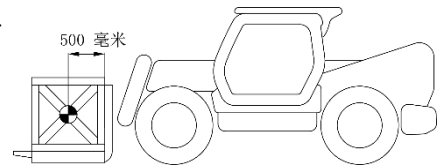

When handling the goods, it must be completely against the fork frame, and the fork length should be at least 2/3 of the length of the goods. The load chart for this machine is suitable for cargo with a longitudinal center of gravity position of 500 mm from the bottom of the fork. For centers of gravity that exceed this value, please consult Zoomlion Service. For irregular cargo, the transverse center of gravity position should be determined in the middle of the two forklifts before operation.

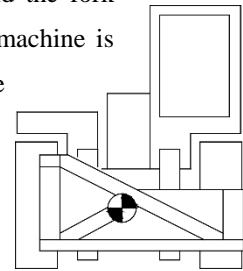

If the weight of the goods cannot be placed at the specified height and angle, following solutions can be used:

- Move the machine closer to the loading and unloading point so that the weight of the cargo meets the requirements of the rated load chart.
- Divide the cargo into smaller sections so that each section conforms to the load rating chart.
- Replace a machine with a greater capacity to handle cargo within the prescribed limits.

**4.6.1 Pick up good at ground**

■ For pallet cargo

- a) The machine is vertically close to the goods, the main boom is fully retracted, and the fork is in a horizontal position;
- b) Adjust the fork spacing and place the goods in the center of the fork.

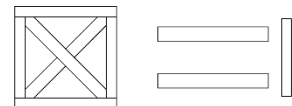
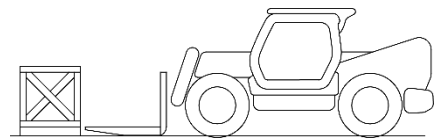

**⚠ DANGER**

Lifting goods with a single fork is prohibited

**⚠ CAUTION**

When manually adjusting the fork, be careful of arms or legs snagging or squeezing.

- a) The machine moves slowly forward until the fork door frame is close to the goods;
- b) Gently raise the fork arm and tilt the cargo backward as far as possible (to avoid the cargo falling off during braking or downhill), and ensure that the cargo is at least 300mm above the ground.

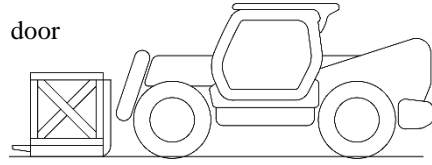

■ For non-pallet cargo

- a) Tilt the fork forward and slowly move the fork forward to insert the fork under the goods (lock the goods if necessary);
- b) Move the fork forward while tilting the fork back to place the goods on the fork and check the longitudinal and lateral stability of the goods.

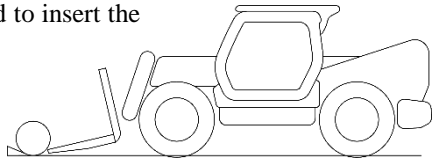

### 4.6.2 Place goods

- a) Place the gear in "N" position after the vehicle vertically the position where the goods are placed;
- b) Adjust the left and right level of the vehicle, if the left and right level indicator or the front and rear level indicator is not 0 degrees.

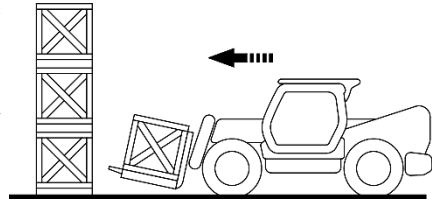

**! DANGER**

**Make sure the machine is level before lifting the boom, otherwise there is a risk of tipping!**

- a) Raise and extend the boom above the desired position, and observe the longitudinal stability limiter and alarm equipment during operation. Remove the machine if necessary;
- b) Lower and retract the boom until the weight is completely detached from the fork. Do not exert downward force on the fork;
- c) Alternately retract and raise the boom until the fork is free of the cargo;
- d) When the fork is detached from the cargo and structure, the boom can be lowered and retracted. Then return the fork to the handling position.

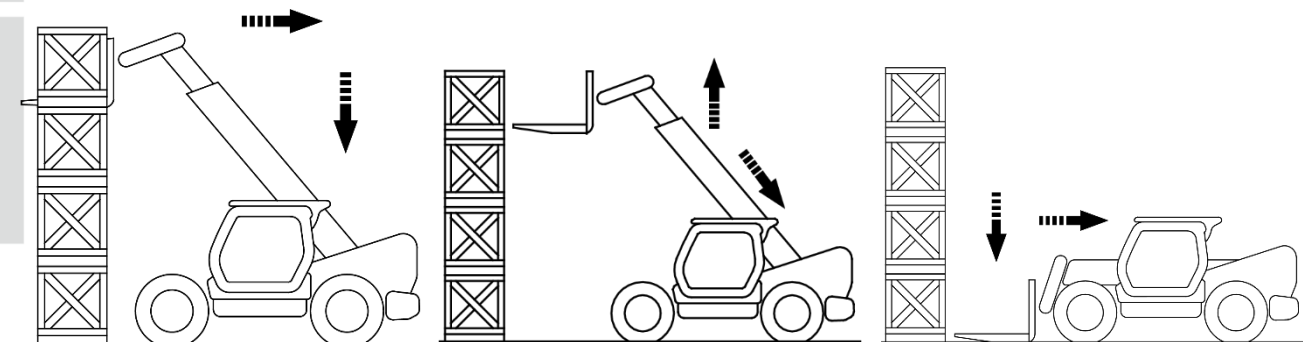
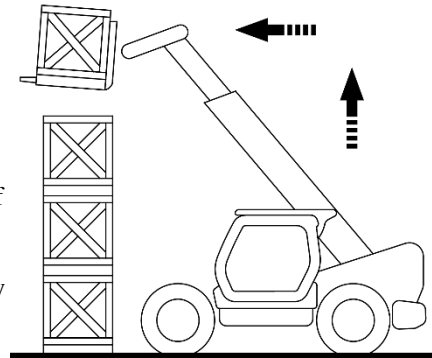

### 4.7 Attachment fast change

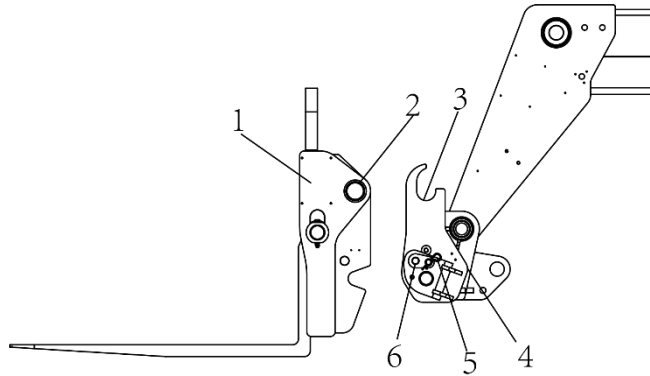
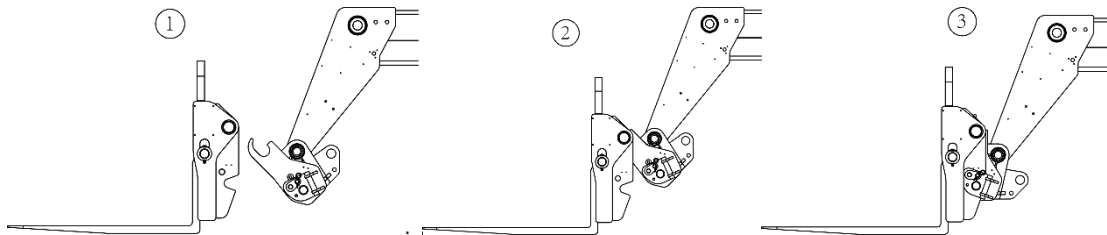

Figure 4-1 Attachment fast change structure

Table 4-1 Attachment fast change instruction

No.	Item	No.	Item
1	Accessories pack	4	Connecting device
2	Connecting pin	5	Mechanical plug
3	Fast change connecting groove	6	$\beta$ lock pin



- a) Tilt the connection device backwards and ensure that the mechanical latch is removed;
- b) Align the groove of the connecting device with the connecting pin of the accessory, gently raise the boom, and move the connecting pin into the groove;
- c) Tilt connection device forward to ensure that the connection device is connected to the accessory;

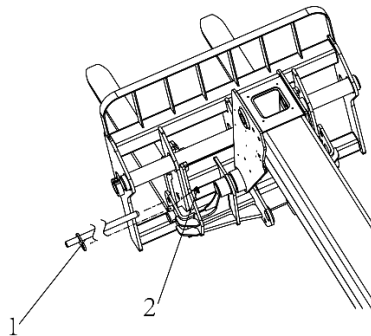

- d) Lift the mechanical latch (1) into the connecting device completely and fix the  $\beta$  locking pin (2);
- e) Connect auxiliary hydraulic hose or auxiliary wiring harness if equipped.

### ⚠ CAUTION

After the mechanical latch is removed, place the latch in the specified position.

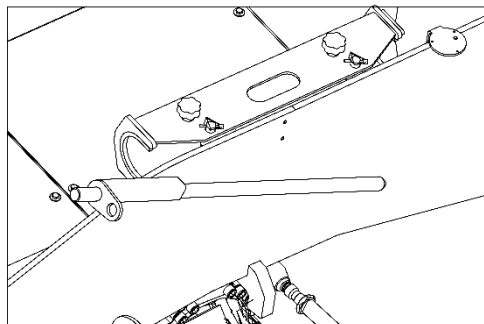

## 4.8 Attachment select

Only accessories approved by the manufacturer are allowed on the machine. Before use, ensure that accessories are properly installed and locked according to the requirements for loading and unloading accessories. Determine that the selected accessory is appropriate for the work to be performed.

For machines with accessories, the corresponding load chart should be followed. Do not exceed the rated capacity.

## 4.9 Traction operation

Obey following regulations:

ZOOMLION provides this safety information for advice. If you need to use a trailer, check the current regulations in your country. Before use, please confirm the trailer condition. It is prohibited to tow trailers or equipment that are not working properly. A trailer in poor condition may affect the steering and braking and resulting in a risk of safety.

The operator is fully responsible for ensuring that the machine is properly secured and that the correct trailer is selected in accordance with national and local regulations and company policies.

### ⚠ WARNING

**It is prohibited to tow a trailer or equipment that is not working properly. A trailer in poor condition may affect the steering and braking and resulting in a risk of safety.**

If a third party assists in connecting or disconnecting the trailer, the driver must be able to see the person at all times before the machine stops.

The trailer hook is located at the rear end of the machine and its carrying capacity is limited by the gross weight of the telehandler, the traction force and the vertical force at the connection point specified for each machine. This information is indicated on the nameplate.

- a) Keep the machine as close to the trailer ring as possible;
- b) Turn off the engine, lift the trailer pin, and attach or remove the trailer ring.

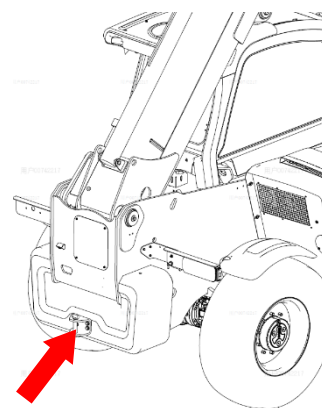

**⚠ CAUTION**

Be careful not to get your fingers caught or pinned.

**4.10 Suspended cargo transport**

- a) When transporting suspended goods, ensure that the boom is fully retracted;
- b) b) Ensure that the operator maintains direct communication (such as verbal or gesture) with the information clerk, without other obstacles;
- c) c) Lift the goods off the ground, it is forbidden to lift the goods more than 300 mm from the ground or the boom angle larger than 45°;
- d) d) Drive slowly at a low speed and pay attention to the surrounding environment or signal requirements.

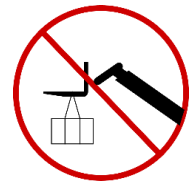

**⚠ CAUTION**

The speed when transporting suspended goods shall not exceed 0.4m/s.

**4.11 Connecting device- Hoisting rings**

**⚠ CAUTION**

Conditions of use

- 1) The ring must be used when there is no fork and accessories, and the fork must be kept level at all times.
- 2) When using the lifting ring, ensure that the lifting ring is placed directly above the load to avoid horizontal sliding of the load.
- 3) When using the ring, do not change the angle of the fork.
- 4) The minimum carrying capacity of the hook, chain and sling is 4000kg, and the safety factor is 4.0.

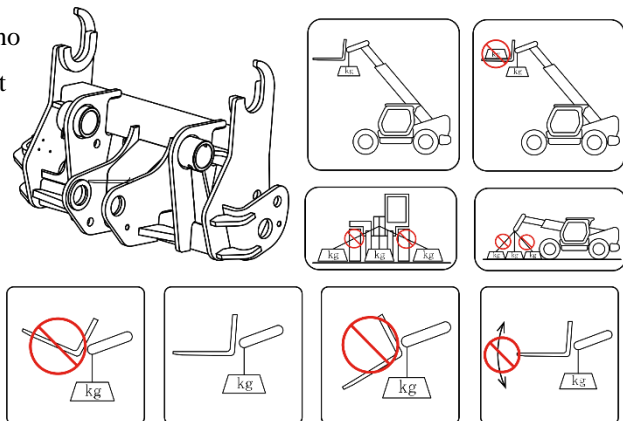

**4.12 Engine regeneration (if equipped)**

When the engine regeneration reminds occur, please do the following:

- a) Drive the vehicle to an open area without flammable materials and put the machine in "N" gear;

- b) Turn on the parking regeneration switch of the engine and do not step on the accelerator pedal or other control devices during the regeneration process;
- c) The indicator light blinks during the regeneration process, and the time is about 30 to 60 minutes.

**! CAUTION**

**During the regeneration process, the exhaust temperature is high, please pay attention to flammable materials and keep away from the exhaust port.**

**! CAUTION**

**If the engine regeneration is not performed in time, it may result in engine damage.**

**4.13 Load chart instruction**

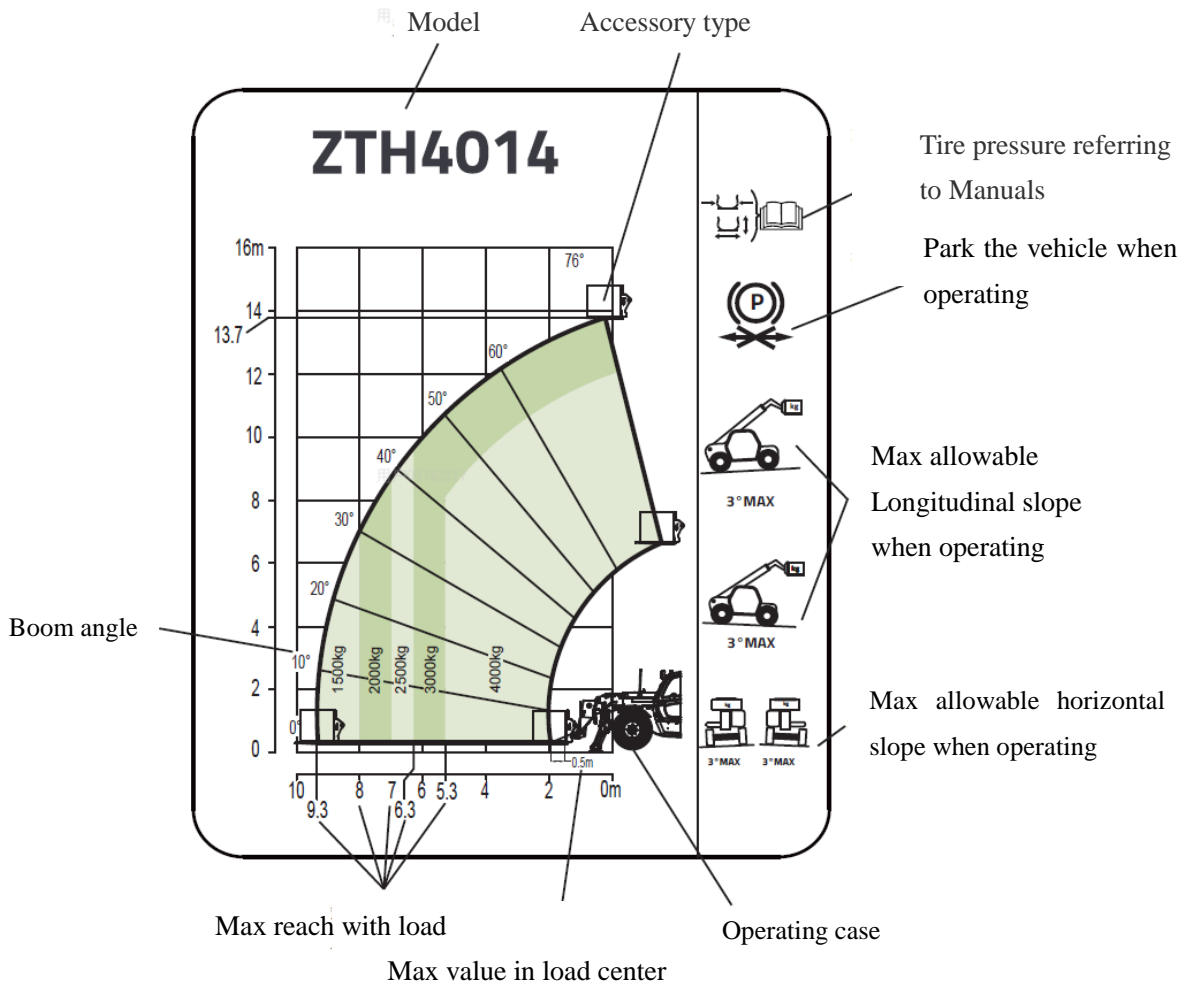

**! CAUTION**

The above figure is for reference only, please do not use it for actual work. Please refer to the manual in the cab for practical operation.

**! CAUTION**

All loads on the load chart assume that the vehicle is on a level ground and are required to ensure that the tire pressure meets the specified requirements. If outriggers are applied, the front wheels should be off the ground.

OPERATION INSTRUCTION

### 4.14 Air condition (if equipped)

#### 4.14.1 Refrigeration mode

- Start the engine, operate the cab display screen to enter the air conditioning operation interface;
- Turn on the air conditioner switch "OFF", and green indicator is on; Adjustable wind speed: high, medium and low;
- Turn on the A/C cooling switch and the A/C indicator (green) is on.



#### 4.14.2 Heating mode

- Start the engine, operate the cab display screen to enter the air conditioning operation interface;
- Turn on the air conditioner switch "OFF", and green indicator is on; Adjustable wind speed: high, medium and low;

Before using the heating mode, ensure that the engine air conditioner switch is turned on. The



switch direction is consistent with the pipeline direction.



- During the warranty period, without the consent of the manufacturer, the user is strictly prohibited to disassemble the air conditioning system;
- Regularly check the tightness of the compressor belt and adjust it in time;
- Regular cleaning condenser;
- When inspecting the air condition, the refrigerant and compressor freezing oil of the same brand should be added as required;
- When parts in the system fail, spare parts provided by the manufacturer should be used for replacement;
- Check the evaporator at any time under low temperature and high humidity conditions to prevent the evaporator from freezing and clogging;
- When the air conditioner is not used in cold areas or winter, the air conditioner should be turned on for about 10 minutes every month.

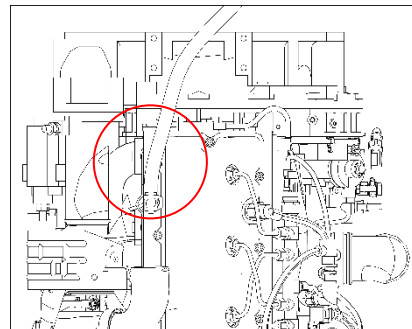

 **CAUTION**

- a) Check the refrigerant frequently. If the refrigerant is insufficient, add it in time
- b) If there is abnormal vibration, noise, odor during operation, it should be stopped immediately for inspection, and it should not run with fault;
- c) The outer surface of the condenser should be cleaned regularly, and no steam should be used during cleaning;
- d) Remove the refrigerant before disassembling the air conditioner;
- e) It is strictly prohibited to remove the air conditioning system in a high humidity environment.



# **ZOOMLION**

## **Telehandler Operation Manual**

### **Section 5 MAINTENANCE**





## SECTION 5 MAINTENANCE

### 5.1 General



Observe and Obey:

Only routine maintenance items specified in this manual shall be performed by the operator.

Scheduled maintenance inspections shall be performed by qualified service technicians, according to the manufacturer's specifications and the requirements listed in the responsibilities manual.

Disposal of materials should be according to the regulations of government and relevant environmental protection administration.

Use only ZOOMLION approved replacement parts. ZOOMLION assumes no responsibility for hazards occurred to equipment and personnel caused by the use of unauthorized parts.

#### 5.1.1 Maintenance Symbols Legend

The following symbols have been used in this manual to help communicate the intent of the instructions. When one or more of the symbols appear at the beginning of a maintenance procedure, it conveys the meaning below.



Indicates that tools will be required to perform this procedure.



Indicates that new parts will be required to perform this procedure..



Indicates that a cold engine is required before performing this procedure.

#### 5.1.2 Pre-Start Inspection

- a) Be sure operator's, safety, and responsibilities manuals are complete, legible, and in the storage container located on the machine.
- b) Be sure all decals are in place and legible.
- c) Check for hydraulic oil leaks and proper oil level. Add oil if needed. See Inspections section.
- d) Check for battery fluid leaks and proper fluid level. Add distilled water if needed after battery charged.

Check the following components or areas for damage, improperly installed, or missing parts and unauthorized modifications:

- 1) Electrical components, wiring, and electrical cables.
- 2) Hydraulic hoses, fittings, cylinders, and manifolds.

- 3) Axle and transmission.
- 4) Wear slider and liner.
- 5) Tire and wheel;
- 6) Limit switches, alarm and horn.
- 7) Alarm and indicator (if equipped).
- 8) Nuts, bolts and other fasteners.
- 9) Brake release unit.

### 5.1.3 Maintenance hazards

- a) Shut off power to all controls and ensure that all moving parts are secured from inadvertent motion prior to performing any adjustments or repairs.
- b) Never work under an elevated platform until it has been fully lowered to the full down position, if possible, or otherwise supported and restrained from movement with appropriate safety props, blocking, or overhead supports.
- c) DO NOT attempt to repair or tighten any hydraulic hoses or fittings while the machine is powered on or when the hydraulic system is under pressure.
- d) Always relieve hydraulic pressure from all hydraulic circuits before loosening or removing hydraulic components.
- e) DO NOT use your hand to check for leaks. Use a piece of cardboard or paper to search for leaks. Wear gloves to help protect hands from ejective hydraulic oil.



### 5.1.4 Body injury hazard

Do not operate a machine with a hydraulic oil or air leak. An air leak or hydraulic leak can penetrate and/or burn skin. During or after a period of running of the hydraulic system, the parts may produce high surface temperature, and improper contact will cause burn to skin. Overhauling or adjusting any part of hydraulic system can cause serious injuries. Only trained maintenance personnel are allowed to repair or adjust the hydraulic system.

Suggestion: Access by the operator is only advised when performing a pre-operation inspection. All covers must remain closed and secured during operation.

## 5.2 Maintenance schedule

**Table 5-1 Maintenance schedule (which comes first)**

A-adjust, C-check, G-grease, N-neat, V-vent, R-replace, D-drain	10h	50h	250h	500h	1000h	2000h	4000h	6000h
	Each day			Half a year	Every year	Every 2 years		
Power system								
Engine oil level	C							
Coolant level	C							
Fuel level	C							
Fuel first class filter	C							
Air filter			N					
Engine belt tension			C/A					
Engine oil		R (first maintenance )		R				
Engine oil element		R (first maintenance )		R				
Fuel first class filter element				R				
Fuel second class filter element				R				
Fuel tank						N		
Engine air filter element				R				
Coolant level						R		
Urea pump filter element (if available)							R	
Urea tank filter (if available)							R	
DPF filter (if available)								R
Transfer case								
Gear box oil level			C					
Gear box oil				D				
Cardan joint		G						
Driving axle								
Drive axle reducer pivot		G						
Drive axle differential oil level			C					

A –adjust, C-check, G-grease, N-neat, V-vent, R-replace, D-drain	10h	50h	250h	500h	1000h	2000h	4000 h	6000 h
	Each day			Half a year	Every year	Every 2 years		
Wheel differential oil level			C					
Drive axle differential oil				D				
Wheel differential oil					D			
Cardan joint		G						
Tire								
Tire pressure	C							
Wheel nut torque	C							
Tire					C**			
Boom system								
Boom		G*						
Slider check			C					
Extension synchronization calibration	A							
Internal boom line		C				R**		
Slider wear					C**			
Boom wear						C**		
Hydraulic system								
Hydraulic oil level		C						
Hydraulic feed oil filter				R				
Hydraulic oil					D			
Hydraulic tank						N**		
Brake system								
Brake oil level		C						
Brake oil					D**			
Brake system					V**			
Brake system pressure					C**			
Brake					A**			
Steering system								
Steering						C**		

A –adjust, C-check, G-grease, N-neat, V-vent, R-replace, D-drain	10h	50h	250h	500h	1000h	2000h	4000 h	6000 h	
	Each day			Half a year	Every year	Every 2 years			
Steering knuckle		G							
Cab									
Wiper cleaning fluid level		C							
Cab vent filter element		N	R						
Electrical system									
Anti-tilting system	C								
Battery						C**			
Frame system									
Outrigger		G							
Chassis leveling device		G							
Rear axle float lock device		G							
Attachment									
Platform		G							
Movable fork		G							
Fork wear				C**					
Connecting device wear					C**				

(\*): Every 10 hours for the first 50 hours and every 50 hours thereafter.

(\*\*): Consult your dealer or after-sales service personnel

(\*\*\*): First replacement

## 5.3 Power system maintenance

### 5.3.1 Engine oil

Maintaining the engine oil at the proper level is essential to engine service life. Insufficient engine oil will result in permanent damage to engine.

Check the oil scale daily, ensure that the oil level is between the highest scale and the lowest scale. Select different types of oil according to the ambient temperature and engine configuration (see Table 5-1).

**CAUTION :** Check the oil level while the engine is off.

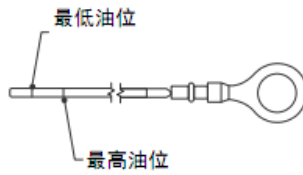

Figure 5-1 Oil level dipstick

Table 5-1 Recommended oil models at different ambient temperatures

Table 5-2 Engine oil type	Temperature
CK-4 20W-40	Above -15°C
CK-4 15W-40	(-20 - -15) °C
CK-4 10W-40	(-25 - -20) °C
CK-4 5W-40	(-30 - -25) °C
CK-4 0W-40	(-35 - -30) °C



Engine oil level inspection:

- 1) Place the machine on a level ground, stop the engine, and wait for the engine to cool.
- 2) Open engine hood and remove oil gauge.
- 3) Clean the dipstick and check that the oil level is correct between the two grooves of the dipstick.
- 4) If necessary, add oil through the oil filler port.
- 5) Visually check no oil leakage in the internal combustion engine.

### 5.3.2 Fuel inspection

Qualified fuels guarantee good engine performance, long lifespan and acceptable emission, on the contrary, poor fuel will result in engine fault and substandard emission. It is recommended to use GB 19147 standard fuel in China, EN590 standard fuel in the European Union and ASTM D975 standard fuel in North America.

Select different types of fuel for different ambient temperatures, as listed in Table 5-2.

Table 5-2 Fuel refill requirement under different temperature

Temperature	Fuel type
(-44 to -29) °C	-50#
(-29 to -14) °C	-35#
(-14 to -5) °C	-20#
(-5 to 4) °C	-10#
(4 to 8) °C	0#
Above 8°C	5#

If you use biodiesel, please follow the relevant national standard fuel (see Table 5-3) :

**Table 5-3 Recommended biodiesel specifications for different countries or regions**

Country or region	Bodiesel specifications	Diesel specification
European	B7	EN590
	GTL	EN15940
	HVO	
Indonesia	B20	SNI7182
	B30	
	B40	
Brasil	B14	Refer to EN590
Thailand	B20	The Department of Energy Business Notification Re :Properties and Quality of Diesel
US	B0-B5	ASTMD975
	B6-B20	ASTMD7467



Precautions for using biodiesel:

- 1) Keep the tank full as much as possible, and tighten the tank cap to prevent water vapor from gathering in the tank;
- 2) Check the oil level regularly before operation, and strictly comply with the prescribed oil replacement cycle;
- 3) The storage time of biodiesel should not exceed three months;
- 4) When storing the machine for more than 1 month, replace the diesel fuel in the machine with traditional diesel fuel (mineral oil diesel fuel), and operate the machine for 30 minutes or more to clean the fuel system;
- 5) In addition to the daily inspection of the fuel system, the maintenance time of the fuel filter element (including the oil-water separator and the fuel fine filter) is half of the normal maintenance time (example: conventional replacement every 500 hours → replacement every 250 hours);
- 6) When using B20 and above biodiesel, it is necessary to upgrade the fuel system accessories to prevent fuel leakage due to rubber deterioration, accessories models can contact local sales representatives and service personnel.

### 5.3.3 Coolant level inspection



Maintaining the engine oil at the proper level is essential to engine service life. Improper coolant level affects engine cooling performance and risks damage to engine components. Antifreezes of different brands cannot be mixed. It is recommended to use antifreeze with a ratio of antifreeze protection agent (ethylene



glycol) to water at 1:1, such as Great Wall FD-2B (antifreeze to -40°C) coolant.

The coolant level check method is as follows:

- 1) Place the machine on a level ground, stop the engine, and wait for the engine to cool.
- 2) Open the hood and check that the coolant level is between the MAX and MIN scales of the expansion tank.
- 3) If necessary, add oil through the port.
- 4) Visually check radiators and pipes for leakage.



**Body Hazard Beware of hot engine parts and coolant. Touching hot engine parts or coolant can cause serious burns.**



- a) **Burn Hazard** Do not remove the radiator cover while the engine is running. Contact with pressurized coolant can cause severe burns. Remove the radiator cover after the engine cools down;
- b) Check the liquid level in the coolant recycling tank. Add coolant as needed. The level should be visible at the MAX (Full) mark of the coolant recovery tank or in the level gauge. Do not overfill the coolant; Add oil if needed.
- c) In emergency, water can be used as a coolant and the coolant can then be replaced as much as possible.

### 5.3.4 Fuel filter maintenance

- a) First class fuel filter (oil-water separator)



- Drains and impurities

- Open the hood, press the drain valve at the bottom of the first stage fuel filter to drain the impurities and water inside until the diesel comes out.



- Replace filter

- 1) Clean the outside of the filter and base to prevent dust from falling into the system.
- 2) Place a container under the filter and drain the oil through the drain plug.
- 3) Loosen the locking screw and remove the filter clear cover and its seal.
- 4) Use a brush soaked in clean diesel to clean the inside of the filter head and housing.
- 5) After removing the filter element and replacing it, reinstall the new cover and seal cover.



b) Second class fuel filter



- 1) Clean the outside of the filter and base to prevent dust from falling into the system.
- 2) Place a container under the filter and drain the oil through the drain plug.
- 3) Remove the filter housing and its seal.
- 4) Use a brush soaked in clean diesel to clean the inside of the filter head and housing.
- 5) After removing the filter element and replacing it, reinstall the new cover and seal cover.
- 6) Before starting the engine, press the primary filter exhaust rod to remove air from the oil circuit.
- 7) Start the engine and make sure there is no leakage.



**5.3.5 Air filter maintenance**

● Clean filter



- 1) Open the engine hood and press the air filter dust valve to remove dust from the filter.
- 2) Open the air filter cover and remove the main filter element and the safety filter element separately.
- 3) Clean the dust of the main filter element and the safety filter element with air.
- 4) Reinstall the original main filter element and safety filter element into the air filter.

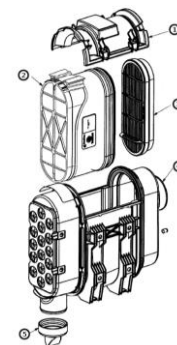

● Replace filter element



- 1) Open the engine hood, open the air filter cover, and remove the main filter element and safety filter element distribution.
- 2) Replace the main filter element and the safety filter element, and install the intake air filter.

**5.3.6 Engine oil filter maintenance**



- 1) Open the engine hood, place a container under the engine oil pan drain port, and loosen the drain screw.
- 2) Clean the outside of the filter and base to prevent dust from falling into the system.



- 3) Place a container under the filter and remove the filter cover and its seal.
- 4) After removing the filter element, gently lubricate the new seal cover and reinstall the new cover and seal cover.
- 5) Reinstall and tighten the engine oil pan drain screw and fill the specified oil through the filling port.
- 6) After starting the engine and running for a few minutes, check and ensure that there is no leakage.
- 7) Stop the engine, check whether the oil level is between the two scales, and fill or discharge the oil if necessary.

### 5.3.7 Urea pump filter element maintenance (if any, Euro V configuration above 56kW)

- 1) Turn off the negative electrode switch;
- 2) Remove the urea pump filter cartridge cover counterclockwise with a 27mm wrench and remove the filter cartridge;
- 3) Replace the new filter element and tighten the urea pump filter cover clockwise (torque: 20N·m).
- 4) Run the engine and check whether the filter element has oil leakage.



### 5.3.8 Urea tank filter element maintenance (if any, Euro V configuration above 56kW)

- 1) Turn off the negative electrode switch;
- 2) Remove the urea level, temperature and quality sensor with a 12mm wrench;
- 3) Press the clip ①, remove the urea tank filter element;
- 4) Install the new filter element, install the quality, level and temperature sensor back into the urea tank, and check whether there is positive urea injection in the post-treatment.

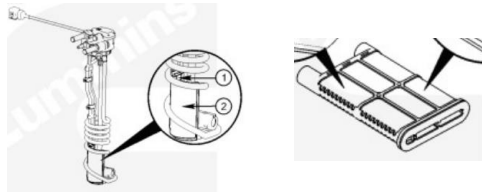

### 5.3.9 DPF filter element maintenance (if any, China IV, Euro V configuration)

- 1) Turn off the negative electrode switch;
- 2) Remove the differential pressure sensor and control module on the post-processing;
- 3) Open the clamp at both ends of the DPF filter element and take out the DPF filter element;
- 4) Replace the new DPF filter element, install the clamp, pressure difference sensor and control module (tightening torque of the clamp 10N·m).

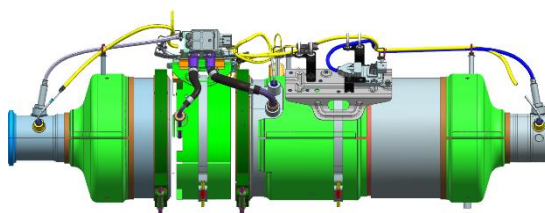

### 5.3.10 Radiator maintenance

The heavy dust environment may cause the heat sink to be blocked. Before and after use every day, use a fan to blow back the heat sink to blow out the dust and other impurities that are blocking the core of the heat sink.

Specific operations are as follows:

- 1) Power on and start the engine;
- 2) Turn on the fan backblow switch (as shown below) at the low idle speed (900rpm), press the accelerator pedal, and maintain the rated engine speed (2300rpm) for about 1 minute;



- 3) Release the accelerator pedal, let the engine speed drop to low idle speed, turn off the fan backblow switch;
- 4) Clean up the debris with a hair dryer or brush.

If the reverse blowing is not carried out for a long time, it may cause serious blockage of the radiator core, resulting in reduced heat dissipation performance, and then cause the engine high temperature alarm or shutdown. If this happens, please handle it as follows.

Specific operations are as follows:

- 1) Use a hair dryer or brush to clean up loose debris on the surface of the radiator (as shown below);



- 2) Turn the negative electrode switch of the vehicle to the "off" state, and use a pressure water gun within 1Mpa to wash the radiator core until most of the debris in the core is cleared out (as shown below);



**Note: Excessive nozzle pressure can cause the radiator fins to fall over.**

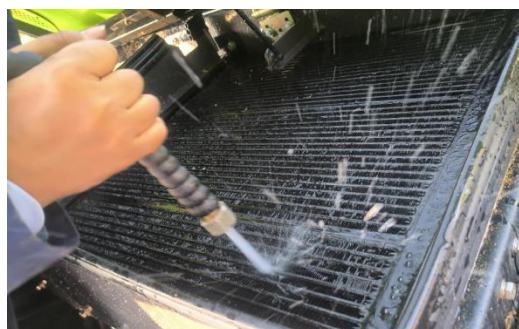

3) Turn on the negative switch of the car, start the engine, step on the accelerator pedal to the maximum position, continue to do the arm retract pressure action for 10-15 minutes, dry the water inside the radiator core and the remaining few debris surface, release the accelerator pedal, let the engine reduce to low idle speed, turn on the fan backblow switch, step on the accelerator to the end, backblow for about 1 minute. Blow out the remaining debris inside the core, and clean up the debris with a hair dryer or brush (as shown below).



**Note: If the inside of the core cannot be completely cleaned up once, steps 2) and 3) can be repeated until the foreign matter inside the core is cleaned up.**

### 5.3.11 Engine regeneration (China IV, Euro V)

#### 1) Driving regeneration

During the use of the equipment, the post-processing carbon load will increase with the use of the equipment. When the engine set value is reached and the exhaust temperature is higher than 250 ° C, the engine will automatically enter the regeneration, and the equipment can be used normally without stopping, but it must be ensured that the use environment is not in a non-flammable and explosive area.

#### 2) Parking regeneration

Under some conditions with low load, the engine exhaust temperature is relatively low, and the driving regeneration cannot be carried out. After the equipment is used for a period of time, the parking regeneration request will be triggered, and the display regeneration request light will be lit. At this time, the equipment needs to carry out parking regeneration.

park the whole vehicle in a place without fire risk, after starting the engine, press regeneration switch, the engine will automatically enter the regeneration process, and it will take about 40 minutes to complete the regeneration. During the regeneration process, it is forbidden to operate the equipment and turn on the regeneration prohibition switch, and the engine will automatically return to idle after the parking regeneration.



**During regeneration, the exhaust temperature is higher than 600°C. Select a safe area for regeneration.**

When the equipment enters the inflammable and explosive area, please turn on the regenerative prohibition switch. When the machine leaves the inflammable and explosive area, turn off the regeneration prohibition switch immediately, otherwise it will lead to the blockage of DPF filter element and limit the engine power. If the equipment works in inflammable and explosive areas for a long time, it is necessary to move the machine regularly and regenerate it.

### 5.3.12 Engine maintenance

#### 1) Engine crankcase breathing port maintenance

Visual observation, check the crankcase breathing tube outlet may be blocked or blocked (mud, debris, ice, etc.), if necessary, wake up and clean.



Frequent ice accumulation in the crankcase breathing tube may require one of the following actions.

1. Install the crankcase breathing tube heater option.
2. If the crankcase breather tube heater is installed, diagnose whether the crankcase breather tube heater is not working.



#### 2) Engine belt maintenance

Visually inspect the belt for cross cracks. Transverse (width-direction) cracks are acceptable. Longitudinal (belt length direction) cracks intersecting with transverse cracks are not acceptable. If the belt is worn or broken, replace it.

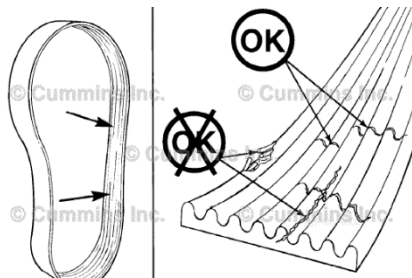

#### 3) Maintenance of engine belt tensioner

1. Visual observation, in the case of engine shutdown, check the tensioner arm, pulley and stop block for cracks. If cracks are found, the tensioner must be replaced.
2. In the case of installing a belt, verify that the two tensioning wheel arm stop block is not in contact with the spring shell stop block. If any of the stop blocks are touched, replace the belt, and if the tensioner arm stop block is still in contact with the spring housing stop block, replace the tensioner.
3. Check the position of drive belt on belt pulley of belt tensioner. The belt should be located in the middle of the pulley, or near the middle. Belt misalignment, whether too far forward or too far back, can cause belt wear, belt rolling failure, or add uneven tensioner bushing wear.

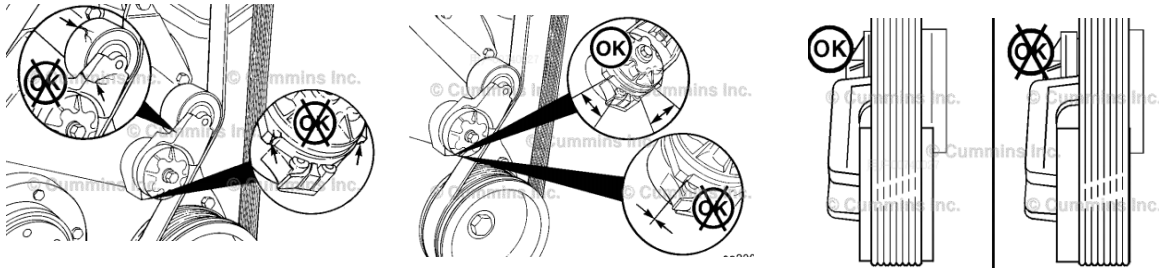

### 5.4 Transfer case maintenance

#### 5.4.1 Transfer tank oil level check

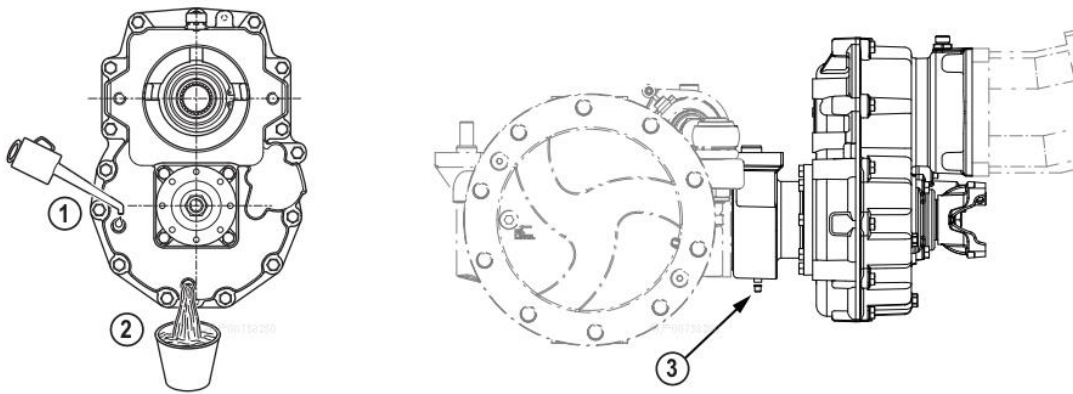

**Figure 5-1 Transfer case**

Above diagram: 1-oil filling port; 2-drain oil port; 3-oil nozzle

No.1 oil filling port, also the oil level observation port. The oil level inspection standard: the oil can be clearly seen flowing slowly in the oil level observation port.

#### 5.4.2 Transfer case oil replacement

Oil requirements and time frequency requirements are as follows:

Item	Description	First inspection time (hours)	Follow-up inspections (hours)	Grease	Standard
Oil level check	All positions	10	Every month		See the oil flowing slowly from the observation port
Replace oil	Transfer case	100-250	1000	SAE80W/90(API GL4orGL5)	

Oil replacement steps as shown in Figure 1:

- a) Open the No.2 port, drain the internal oil
- b) Tighten the No.3 port, and open the No.1 port
- c) Fill the oil from port No. 1, filling standard refer to Section 5.4.1;
- d) Tighten No.1 port

## 5.5 Machine lubricating point

No.	Lubricating points	Qty
1	Rear axle	4
2	Front axle	4
3	Cardan drive axle/front axle	3
4	Cardan drive axle/rear axle	3
5	Boom tail pin	1
6	Boom auxiliary leveling cylinder	2
7	Attachment leveling cylinder pin	2
8	Boom head connecting pin	2
9	Two-section boom sprocket pin	1
10	Boom lifting cylinder pin	2
11	Floating cylinder ( Rear axle )	2
12	Floating cylinder ( Front axle )	2
13	Outrigger cylinder (left)	4
14	Outrigger cylinder (right)	4
15	Boom slider contact surface (first and second boom sections inside and second and third boom sections outside)	16

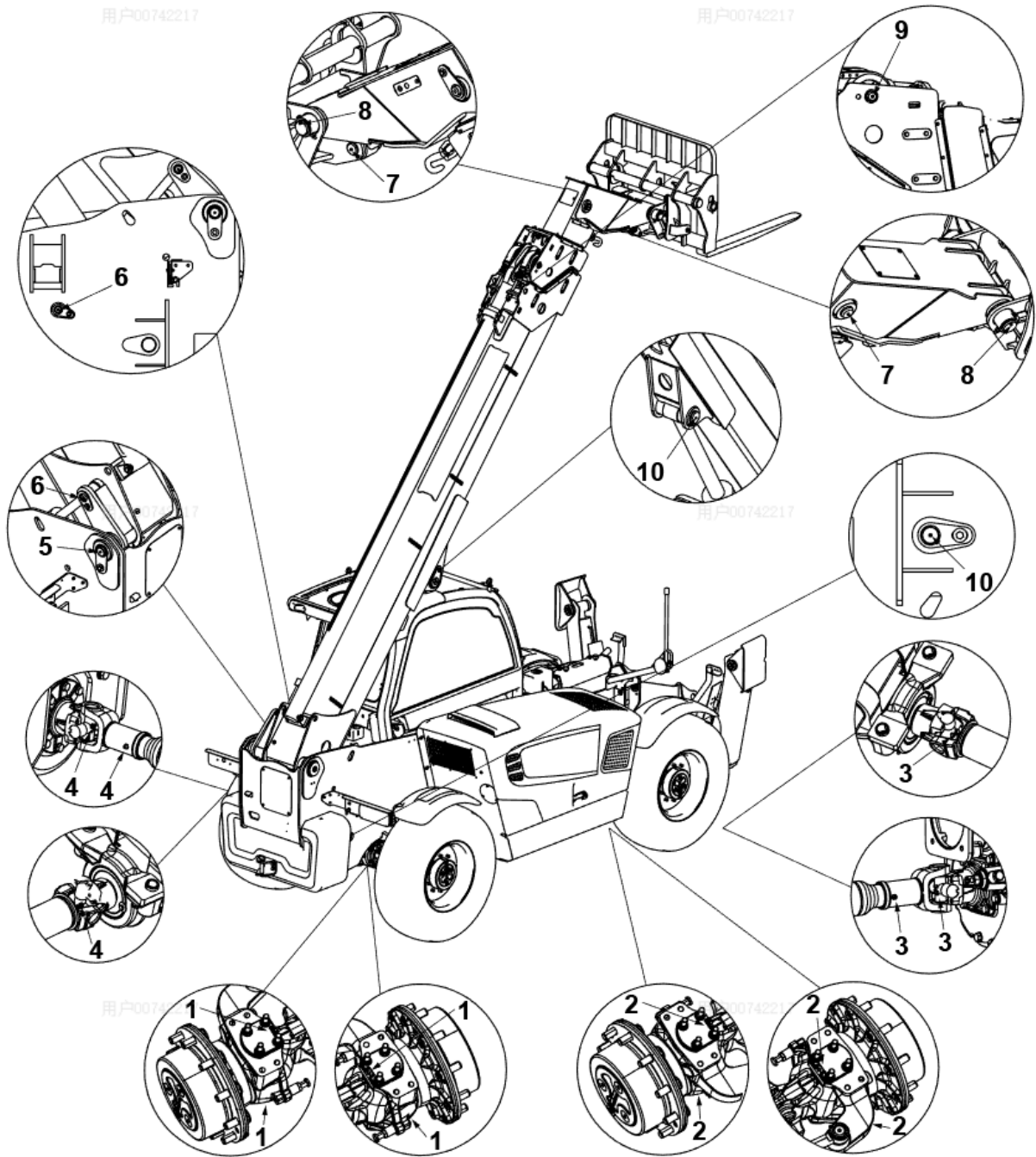

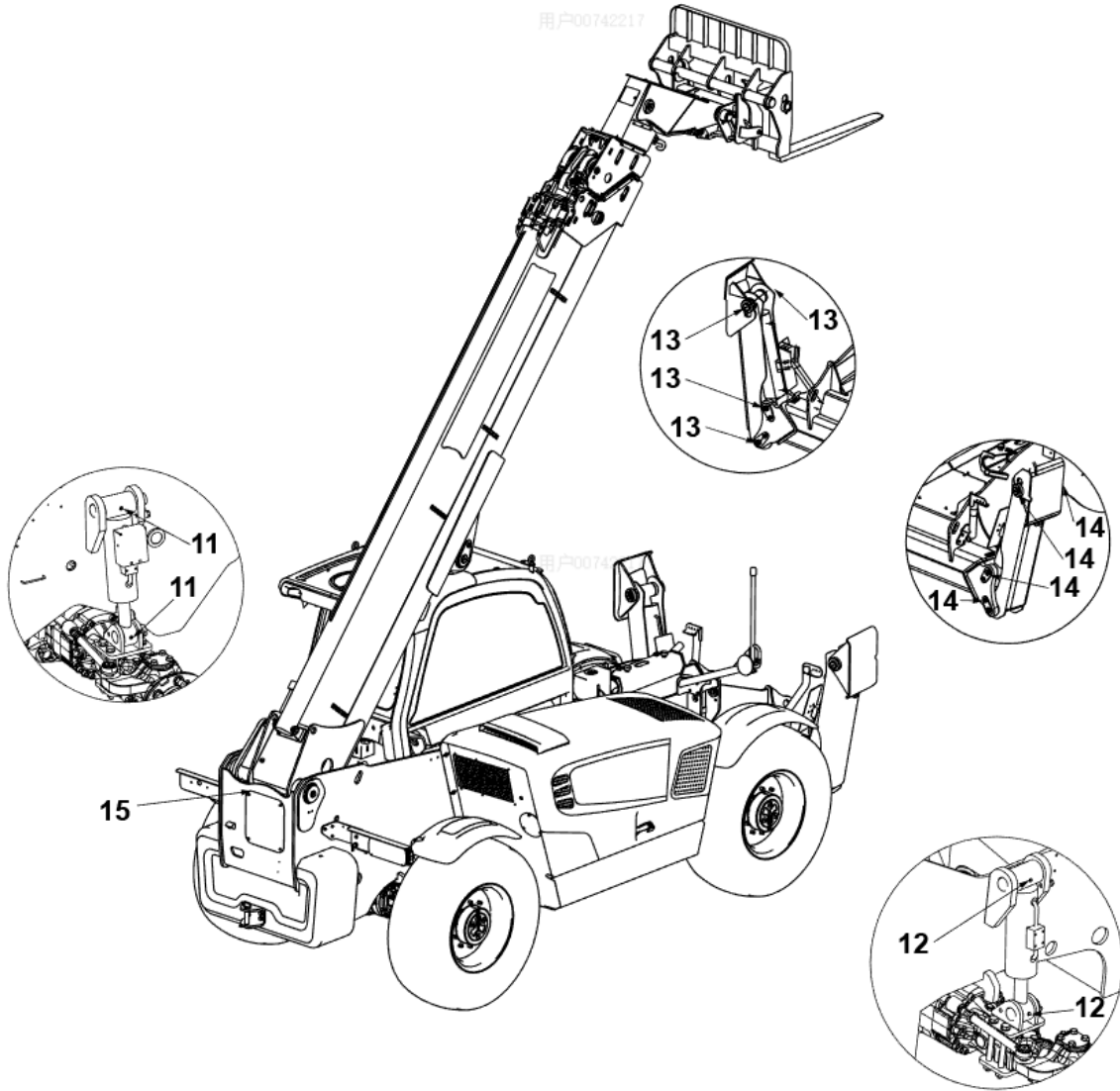

### 5.6 Drive axle maintenance

#### 5.6.1 Drive axle differential gear

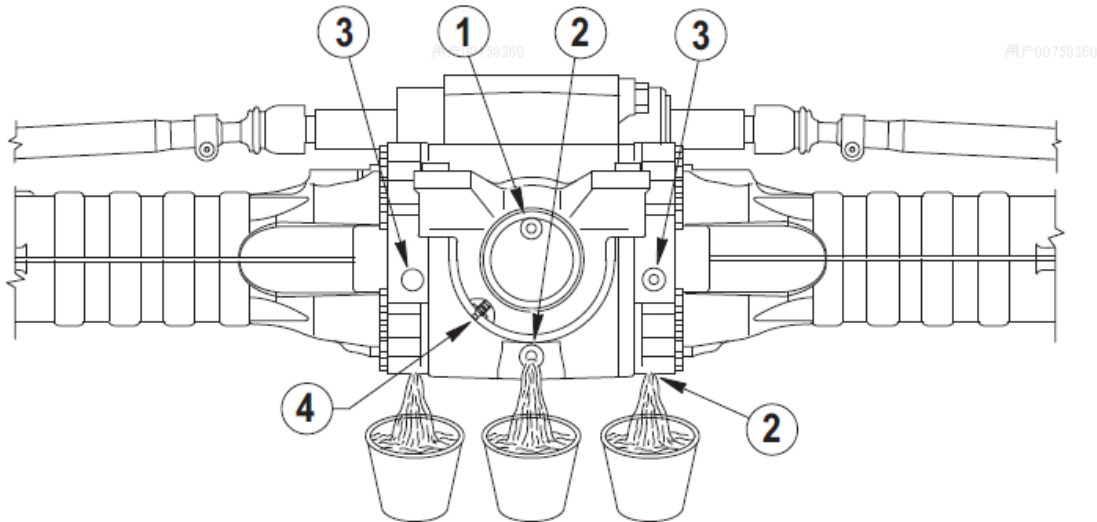

**Figure 5-2 Drive axle**

1: Oil filling port 2: Oil outlet 3: Level check port 4: Glib

Oil level check as well as oil requirements and oil change frequency

Item	Description	First inspection time (hours)	Follow-up inspections (hours)	Grease	Standard
Oil level check	All positions	10	Every month		See the oil flowing slowly from the observation port
Replace oil	Central reducer	100-250	1000	SAE80W/90(API GL4orGL5) Also note that oil with LS additive should be used if the differential band slip is limited or the axle has wet braking	
Grease	Swinging frame bushing	10	Every week	NLGI2EPorNLGI3EP	Add grease until clean grease is visible from the outside

The steps for replacing oil are shown in Figure 2:

- a) Open port 2 and empty the oil inside the axle;
- b) Tighten port 2 and open port 1 at the same time;
- c) Fill the oil from port 1, observe the oil level from port 3, fill the evaluation criteria as shown in the table above;
- d) Tighten port 1.

**5.6.2 Wheel reducer**

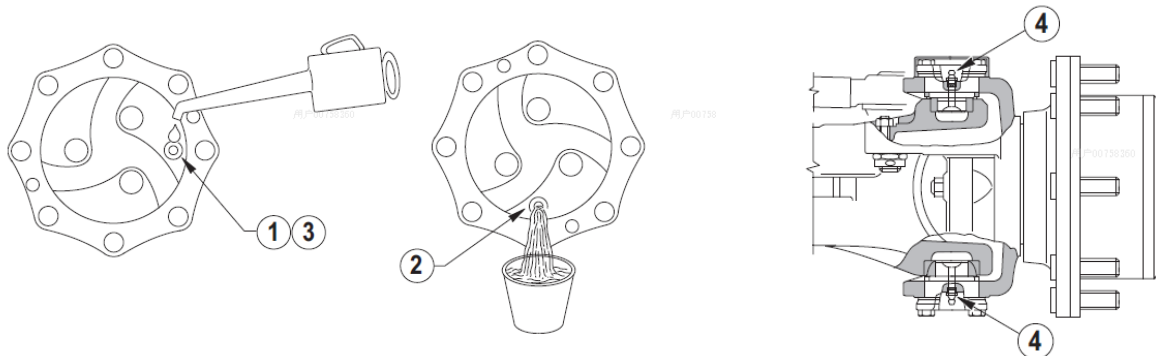

**Figure 5-3 Wheel reducer**

1: Oil filling port    2: Oil draining port    3: Oil level check port    4: Glib

Oil level check as well as oil requirements and oil change frequency

Item	Description	First inspection time (hours)	Follow-up inspections (hours)	Grease	Standard
Oil level check	All positions	10	Every month		See the oil flowing slowly from the observation port
Replace oil	Wheel reducer	100-250	1000	SAE80W/90(API GL4orGL5) Also note that oil with LS additive should be used if the differential band slip is limited or the axle has wet braking	
Lock check	Wheel nut	10	Every 200		Whether the nut mating surface or contact surface is damaged or corroded
Add grease	Tapered roller bearing at kingpin	10	Every week	NLGI2EPorNLGI3EP	Add grease until clean grease is visible from the outside
	Kingpin bushing	10			

The steps for replacing oil are shown in Figure 3:

- a) Open port 2 and empty the oil inside the axle;
- b) Tighten port 2 and open port 1 at the same time;
- c) Fill the oil from port 1, observe the oil level from port 3, fill the evaluation criteria as shown in the table above; It is necessary to pay special attention to the axle wheel refueling and check the liquid level need to roll the refueling port to flush with the height of the center of rotation;
- d) Tighten port 1.

## 5.7 Tire

ZOOMLION recommends a replacement tire be the same size, ply and brand as originally installed on the machine. Please refer to the ZOOMLION Parts Manual for the part number of the approved tires for a particular machine model. If not using a ZOOMLION approved replacement tire,

we recommend that replacement tires have the following characteristics:

- a) Equal or greater ply/load rating and size of original.
- b) Tire tread contact width equal or greater than original.
- c) Wheel diameter, width, and offset dimensions equal to the original.
- d) Approved for the application by the tire manufacturer (including inflation pressure and maximum tire load).

Unless specifically approved by ZOOMLION do not replace a foam filled or ballast filled tire assembly with a pneumatic tire. When selecting and installing a replacement tire, ensure that all tires are inflated to the pressure recommended by ZOOMLION. Due to size variations between tire brands, both tires on the same axle should be the same.

### 5.7.1 Tire pressure

The tyre inflation pressure is 500kPa.

### 5.7.2 Wheel installation

Applying and maintaining the correct wheel mounting torque is extremely important.



**To avoid wheel loosening, bolt breakage, and potentially dangerous wheel separation from the axle, the wheel nut must be mounted with the correct torque and maintained. It must be ensured that the nut used matches the cone angle of the wheel.**

Tighten the nut to the correct torque to avoid wheel loosening. Tighten the fasteners using a torque wrench. If you do not have a torque wrench, use a special wrench for wheel bolts to tighten, and then immediately have the mechanic or agent tighten the nut to the correct torque. Excessive tightening can cause the bolt to break or permanent damage to the bolt mounting holes in the wheel. The correct wheel installation sequence is as follows:

- a) Tighten all nuts by hand first to avoid thread damage. Do not apply lubricant to threads or nuts;
- b) Tighten the nuts in the following order.

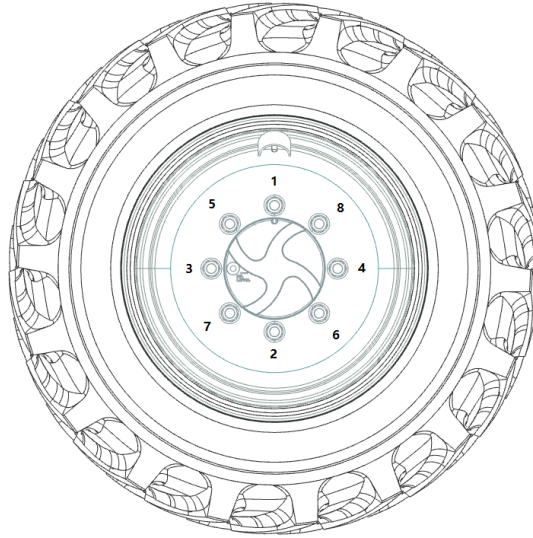

- c) The nut must be tightened several times. Tighten the nuts in the recommended sequence following the wheel torque;
- d) Do not mix lubricating oils of different specifications, let alone low-quality lubricating oils. If the fork is used in a wear environment (such as dust, sand, coal, etc.), in this case, consult your dealer!

Tabel 5-4 Wheel torque

Tightening sequence			
Model	First phrase	Second phrase	Third phrase
ZTH4018	200 Nm	400 Nm	600 Nm

## 5.8 Boom maintenance

### 5.8.1 Boom lubrication

- a) Empty load, horizontal full extension;
- b) Remove old grease from the boom;
- c) Coat the four sides of the boom (where the slider passes) with a layer of grease (Great Wall 3# lithium-based grease is recommended for grease);
- d) Repeat the above steps 3-5 times;
- e) Remove excess oil.



Do not mix lubricating oils of different specifications, let alone low-quality lubricating oils.  
If the fork is used in a wear environment (such as dust, sand, coal, etc.), in this case, consult your dealer!

### 5.8.2 Slider

- Slider wear inspection

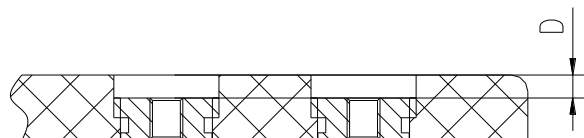

- a) Keep the boom level with no load and extend the boom until the slider to be removed can be removed from the boom;
- b) Lift the boom on the slider to be removed until there is no contact between the boom and the slider;
- c) Remove the fastening bolts fastening the slider and remove the slider;
- d) Check the distance between the friction surface of the slide block and the upper plane of the inserted nut of the slide block D: if the D is greater than 1mm, the slide block can continue to use; Otherwise, replace the slider immediately.
- e) Grease the working surface of the slider (Great Wall 3# Li-based grease is recommended for grease);
- f) Install the slider on the boom and tighten the slider fixing bolt according to the torque value in the table "Tightening torque of the Slider Tightening Bolt" below.

Slider fastening bolt tightening torque	
Bolt spec/specification	Tightening moment
M10	50 Nm
M12	84 Nm

- Replace slider
  - a) Keep the boom level with no load and extend the boom until the slider to be removed can be removed from the boom;
  - b) Lift the boom on the slider to be removed until there is no contact between the boom and the slider;
  - c) Remove the fastening bolts fastening the slider and remove the slider;
  - d) Grease the working surface of the slider (Great Wall 3# Li-based grease is recommended for grease);
  - e) Install the slider on the boom and tighten the slider fixing bolt according to the torque value in the table "Tightening torque of the Slider Tightening Bolt".

### 5.8.3 Boom expansion plate chain maintenance

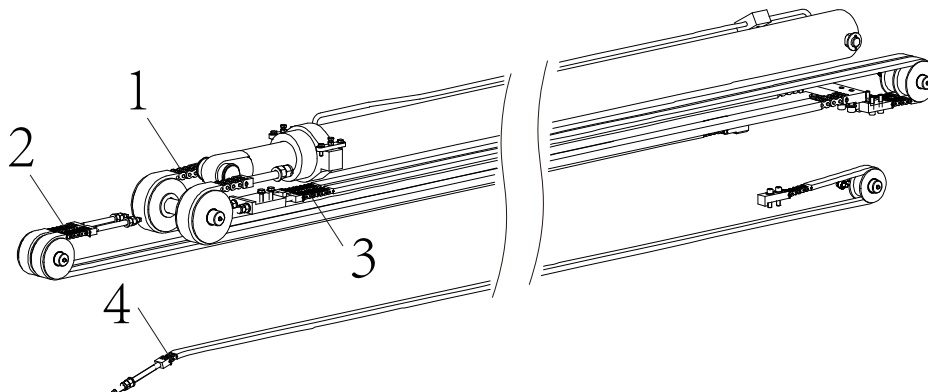

Figure 5-4 Boom expansion plate chain

Boom plate chain tightening torque - ZTH4518R			
No.	Item	Nut spec	Tightening moment
1	First extending boom chain	M24	170Nm
2	Second extending boom chain	M16	50Nm
3	First retracting boom chain	M16	45Nm
4	Second retracting boom chain	M16	40Nm

- a) During the boom expansion process, ensure that the plate chain is properly tensioned. If the plate chain is obviously loose, tighten the plate chain according to the tightening torque table of the plate chain of the boom. Normally, check the tensioning status of the plate chain every 250h.
- b) Each plate chain screw is equipped with a common nut and a locking nut. Loosen the locking nut first, then tighten the common nut to the corresponding torque using a torque wrench, and then tighten the locking nut.
- c) First extending, second extending, second retracting chain, tighten the torque to ensure that the boom is fully shrunk, the boom should be extended 200mm to facilitate the use of extended sleeves when the maintenance of first retracting chain;
- d) The plate chain needs to be lubricated every 50h. If it is parked for a long time (more than one week), grease must be applied to the plate chain to prevent corrosion of the plate chain.
- e) To lubricate the plate chain, drive the vehicle to the open solid flat ground, prop up the legs, use the superair switch to extend the boom horizontally, and then apply the grease to the surface of the first and second plate chain.

## 5.9 Hydraulic system maintenance

### 5.9.1 Hydraulic oil

- a) Hydraulic oil level



Maintaining the hydraulic oil at the proper level is essential to machine operation. Improper hydraulic oil levels can damage hydraulic components. Daily checks allow the inspector to identify changes in oil level that might indicate the presence of hydraulic system problems.

Be sure the machine is on a firm and level surface and in stowed position. By observing oil level in hydraulic oil tank, the hydraulic oil level after excluding air in the hydraulic system should reach the maximum scale mark on the hydraulic oil tank, and not be higher than bottom of the oil tank cap (different

models have different maximum scale).

Add oil as needed. Do not overfill.

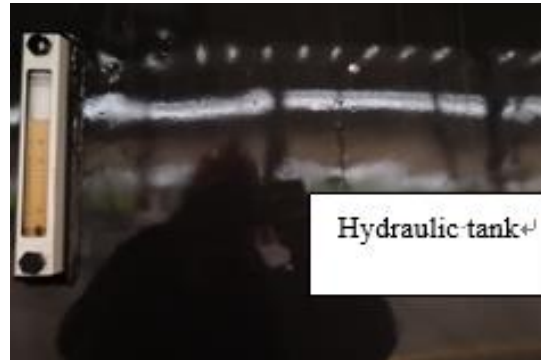

b) Hydraulic oil capacity

**Table 5-5 Liquid level capacity**

Model	ZTH4018
Hydraulic tank	145L
Hydraulic system (including fuel)	230L

c) Hydraulic oil spec

For the recommended hydraulic oil types and models, refer to Table 5-6 hydraulic oil technical parameters. Select the appropriate hydraulic oil according to the specific environment of the equipment. For special environments or users' special requirements, contact ZOOMLION or the hydraulic oil manufacturer.

**CAUTION :** Please do not mix different brands or types of oil, as the mixing of additives in different oils can cause negative effects. If hydraulic oil mixing is unavoidable, it must be allowed by the hydraulic oil manufacturer. Our after-sales service does not cover use failures due to oil mixing.

**Table 5-6 Hydraulic oil parameters**

Technical Parameter	Mobil SHC Aware H 32 (Eco-Friendly)	Mobil DTE 10 Ultra 22	Mobil DTE 10 Ultra 32	Mobil DTE 10 Ultra 46	Caltex Rand o MV 22	Caltex Rand o MV 32	Kunlun 10 aviation hydraulic fluid (Ground)	Great Wall L-H V 32	Great Wall L-H V 46	Great Wall 4632 grease non-flammable hydraulic oil
ISO Viscosity	32	22	32	46	22	32	10	32	46	32
Pour Point (°C)	-30	-54	-54	-45	-36	-36	-50	-39	-37	-20
Flash Point (°C)	185	224	250	232	190	210	92	231	240	270
Motion Viscosity	32	22.4	32.7	45.6	22.5	33.5	10 (50°C)	33.4	48.7	28.8-35.2

Viscosity index	140	164	164	164	155	155	150	150	150	180
-----------------	-----	-----	-----	-----	-----	-----	-----	-----	-----	-----

d) Hydraulic Oil Viscosity and Temperature Limit

Proper use of hydraulic oil: please note the corresponding oil viscosity and temperature limit. Under normal conditions, the recommended oil temperature should be controlled at 30 °C/86°F to 60°C /140 °F . The oil temperature affects the oil viscosity and the thickness of the oil film. High temperatures also shorten the service life of oil seals and other rubber components, and the oil also evaporates and oxidizes.

Pre-delivery of the machine, specific model of hydraulic oil shall be added as required by customer. If machine operating environment temperature is beyond the temperature limit of the hydraulic oil, different hydraulic oil suited to the actual conditions shall be used in time. On account of the safety of machine components and work efficiency, it is advisable that the starting temperature should be 25°C/77°F higher than the pour point of hydraulic oil.

**5.9.2 Return oil filter element**

It is recommended to replace the filter element of the oil return filter every 300 hours or half a year, whichever comes first. A good working return filter element is very important to the performance and service life of the machine. Dirty or clogged filters can affect machine performance and cause part damage if used continuously. In harsh environments and harsh working conditions, the frequency of filter inspection and filter element replacement should be increased.



**5.9.3 Hydraulic tank**



● Tank cleaning

Place a container under the tank drain valve and open the bottom drain valve (Figure A) to ensure that the oil is discharged correctly. After all the hydraulic oil is discharged, open the upper cover plate of the oil tank (as shown in Figure B) and clean the oil tank.

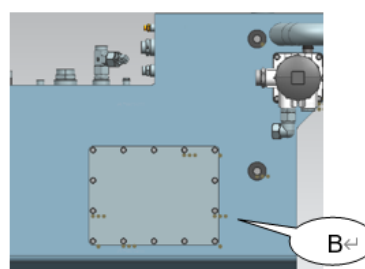
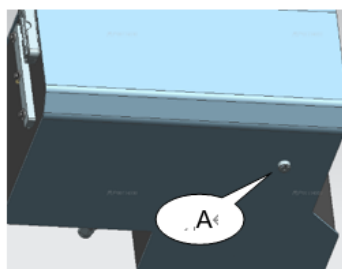

### 5.9.4 Hydraulic hose testing and replacement conditions

Passive detection: When the vehicle is found to have oil leakage, check the hose attached to the oil leakage point, and replace the hose immediately if it is found to be damaged. When the vehicle is abnormal, the rubber hose is detected (refer to active detection).

Active detection: regular inspection of the vehicle hose. In particular, there is relative movement with the structural parts of the hose. Once it is found that the surface of the hose is more serious dermabrasion (visible inner steel wire layer), knock marks (similar to knife cutting marks), bulge, obvious depression, surface oil seepage, oil seepage at the joint, etc., must immediately replace the abnormal hose.



## 5.10 Brake system maintenance

### 5.10 .1 Brake oil



Check that the brake oil tank has sufficient brake oil and is at 2/3 volume.

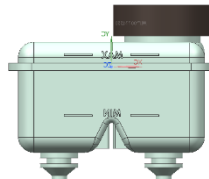

### 5.10.2 Brake system exhaust



Locate the front axle brake exhaust port (BH) (on the outside), remove the rubber cap, loosen the nut, and press the brake cylinder brake pedal continuously until there is continuous oil flowing out of the exhaust port. At this time, keep the brake pedal pressed to the bottom, tighten the exhaust port nut, and cover the rubber cap. Exhaust the four exhaust ports of the front and rear axle in turn, and pay attention to timely replenishment of the brake oil can during the exhaust process.

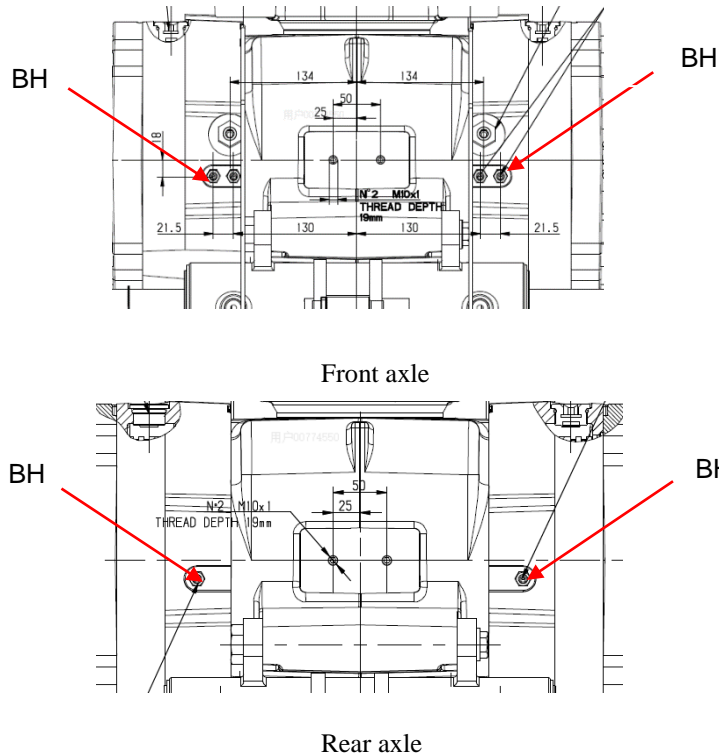

It is necessary to replenish the brake oil can during the exhaust process.

## 5.11 Cab maintenance

### 5.11.1 Wiper cleaning liquid

- a) Open the cover of the wiper kettle and visually measure the liquid level of the cleaning liquid in the kettle;
- b) Add windshield cleaner if necessary;
- c) After adding the cleaning liquid, close the lid of the kettle. It is recommended to check the liquid level of the wiper cleaning liquid once every 30 days. Wiper cleaning fluid level



### 5.11.2 Cab ventilation filter element

- a) Rotate the mounting bolt and remove the rear hood of the cab;
- b) Pull out the filter element from the side of the cab ventilation filter;
- c) Gently tap or clean the filter through compressed air;
- d) Replace the filter element if necessary. We recommend checking the condition of the air filter once a week

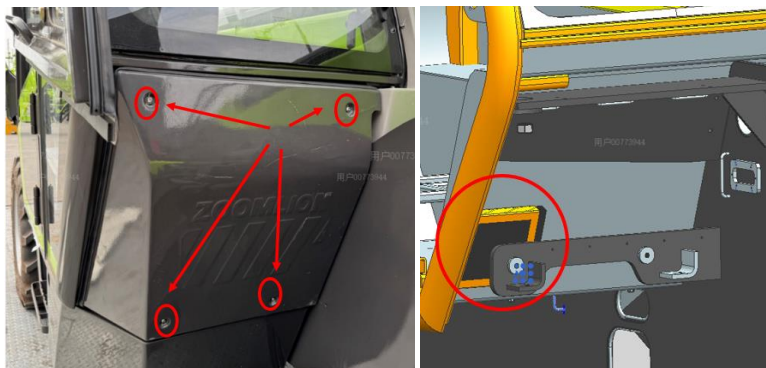

- e) Insert the air filter element into the cab ventilation filter.



For vehicles operating in extremely dusty environments, we recommend setting the filter replacement cycle to work for 10 hours or every day.

## 5.12 Electrical system maintenance

### 5.12.1 Anti-tilting system

In the process of use, if it is found that the items with known weight are forked, the limit amplitude that can be extended differs greatly from the theoretical value in the working performance curve table, it is necessary to re-calibrate the anti-tipping system for system parameters.

Move the machine to a flat cement floor and enter the screen parameter setting - anti-tipping calibration interface. The calibration steps are as follows:

- a) Tire empty load horizontal full retraction calibration -- tire operating conditions, fork empty load, boom full retraction, boom angle maintained  $0^{\circ}$ , enter the anti-tip system calibration page, select the first icon from the left of the first row calibration, click the "confirm" button, the indicator light from red to green, indicating that the status calibration is successful.
- b) Full retraction calibration of tire empty-load maximum angle -- keep the vehicle status unchanged, adjust the angle of the boom to  $72^{\circ}$ , select the second icon from the left of the first row to calibrate, click the "confirm" button, the indicator light turns from red to green, indicating that the status calibration is successful.
- c) Outriggers empty-load horizontal full retraction calibration -- keep the vehicle status unchanged, adjust the angle of the boom to  $0^{\circ}$ , lower the outriggers to fully support the tire off the ground, select the second icon from the left of the second row, click the "confirm" button, the indicator light turns from red to green, indicating that the status calibration is successful.
- d) Full retraction calibration of the outriggers with no load and max angle -- keep the vehicle status unchanged, adjust the angle of the boom to  $72^{\circ}$ , select the third icon from the left of the first row to calibrate, click the "confirm" button, and the indicator light turns from red to green, indicating that the status calibration is successful.
- e) Adjust the angle of the boom to  $0^{\circ}$ , withdraw the outriggers, lift the 2000kg weight with the fork, adjust the amplitude of the boom so that the bottom end of the fork is about 50~100mm away from the ground, slowly extend the boom until the rear wheel is off the ground, select the first icon from the left of the second row, click the "confirm" button, and the indicator light turns from red to green, indicating that the state has been successfully calibrated.
- f) After the calibration is completed, the boom is completely retractable and the operation interface is entered. The progress bar on the right side indicates the longitudinal stability state of the vehicle. Under tire conditions, the fork lifts 2000kg weight and slowly extends the boom until the longitudinal stability progress bar turns into the last grid red. Check that the error between the current amplitude value and the theoretical value in the working performance curve table is less than  $0.2t$ , indicating that the calibration is successful.

### 5.12.2 Battery

Check battery.



**Electric shock hazard**

**Exposure to electrical circuits may result in death or serious injury. Remove all rings, watches and other accessories.**

### **! WARNING**

#### **Body injury hazard**

**Batteries contain acidic substances. Avoid leakage of acidic substances from batteries or contact with them. Use soda and water to neutralize spilled battery acid. Avoid spilling or contacting battery acid.**

**CAUTION :** After the battery is fully charged, check as follows.

- a) Wear protective clothing and glasses;
- b) Ensure that the battery cable is securely connected and not corroded;
- c) Ensure that the battery locking bracket is properly and securely positioned.

**CAUTION :** Adding terminal protectors and anti-corrosion sealants will help eliminate corrosion to battery terminals and cables.

## 5.13 Air condition system

Condenser cleaning:

- a) Ensure that the vehicle is turned off and powered off.
- b) Rotate the outer top mounting bolt and remove the outer top to expose the condenser fan.
- c) Install bolts for rotating condenser fan protective net and remove the protective net.
- d) Wash the protective net and wipe the condenser fan.
- e) Assemble the protective net into place.
- f) Assemble the outer top into place.

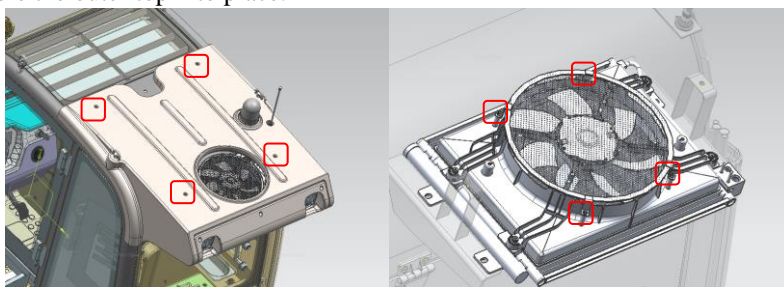

Replace refrigerant:

### **! WARNING**

Do not attempt to replace the coolant yourself, and consult your dealer when the air conditioning effect weakens. Because they have the right accessories and the necessary knowledge and tools.

- Do not, under any circumstances, open the condenser loop, as this will cause the loss of the condenser
- Condensing agent R134a is usually a colorless, odorless gas and is heavier than air.

If this gas is inhaled, move the person to a place with fresh air. Supplemental oxygen or artificial respiration, if necessary to seek medical treatment.

If skin comes into contact with the gas, wash immediately with running water and remove any contaminated clothing.

If your eyes come into contact with the gas, wash them with clean water for 15 minutes and consult a doctor.



Turn off the hot water valve when starting the cold air conditioner.



# **ZOOMLION**

## **Telehandler Operation Manual**

### **Section 6 TRANSPORTATION AND STORAGE**

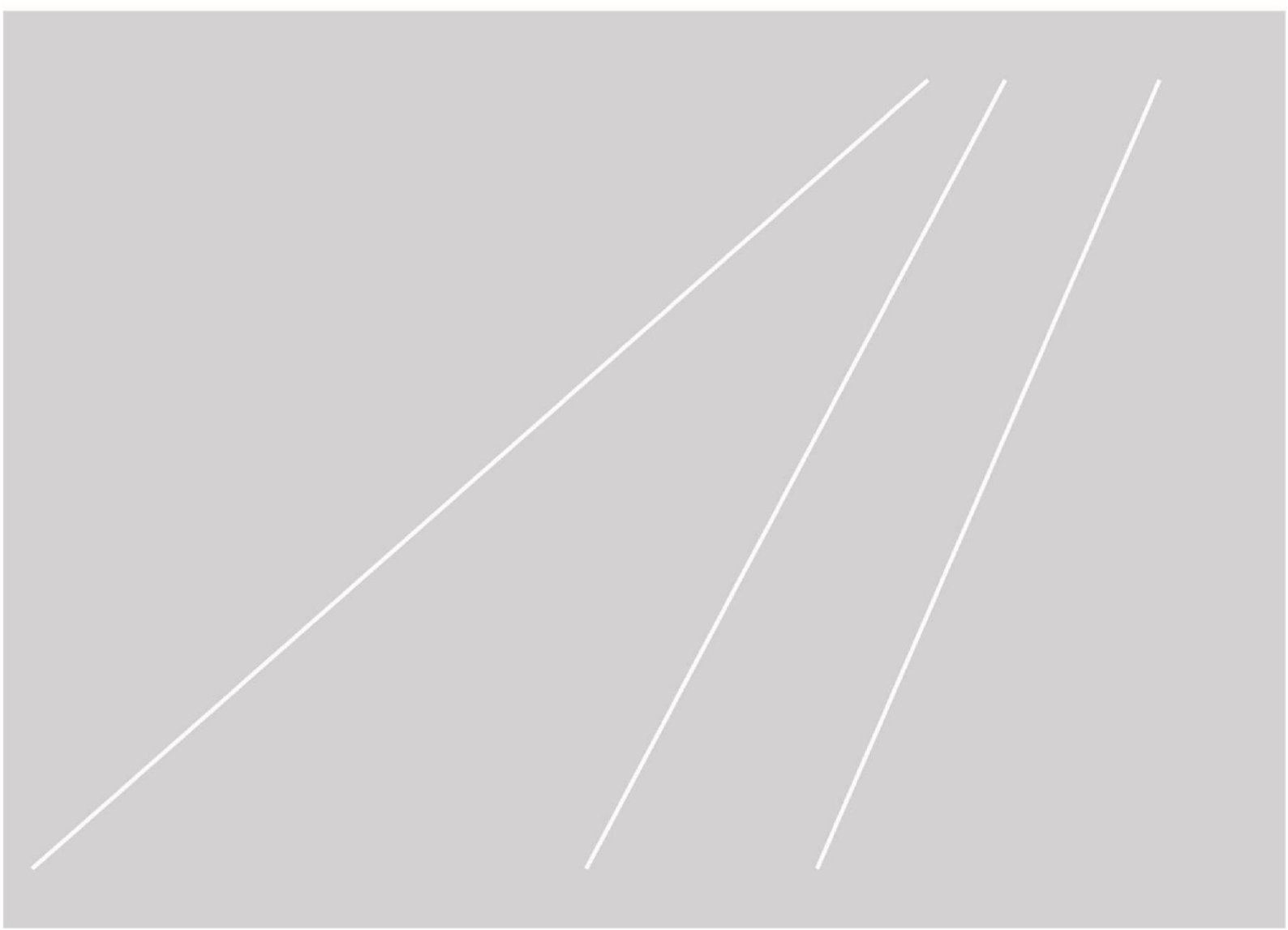



## SECTION SIX TRANSPORTATION AND STORAGE

### 6.1 Transportation

Obey following regulations:

ZOOMLION provides this safety information for advice. The operator is fully responsible for ensuring that the machine is properly secured and that the correct trailer is selected in accordance with national and local regulations and company policies.

ZOOMLION customers who need to use containers to carry any lifting device or ZOOMLION products for international shipments should seek a qualified freight forwarding company with expertise in preparing, loading, protecting containers and lifting equipment.

Only a qualified operator can lift the vehicle in and out of the truck.

Transport vehicles must be parked on level ground.

When loading the vehicle, the transport vehicle must be secured to prevent rolling.

Ensure that the vehicle capacity, loading surface, chain or belt can carry the weight of the vehicle. ZOOMLION lifting equipment is heavy for its size. Please refer to the serial number label for vehicle weight.

Do not drive a vehicle on a slope that exceeds the vehicle's uphill, downhill, or slope rating. See "Driving on Slopes" in the "Operation Instructions" section.

#### 6.1.1 Train or ship transportation

(1) Use vehicle to transport the telehandler for a short distance, and use other carriers to transport the machine for long distance (train or ship). If move the telehandler for a long distance, use blocks to stop the tires, and tire the machine with wire rope. Close window and door to prevent rain and moisture from entering the cab, and lock doors and Windows. If transporting the vehicle by sea, follow protective procedures to prevent corrosion and rust.

(2) Figure 8-1 shows the lifting position of the telehandler. Observe related regulations when hoisting the machine.

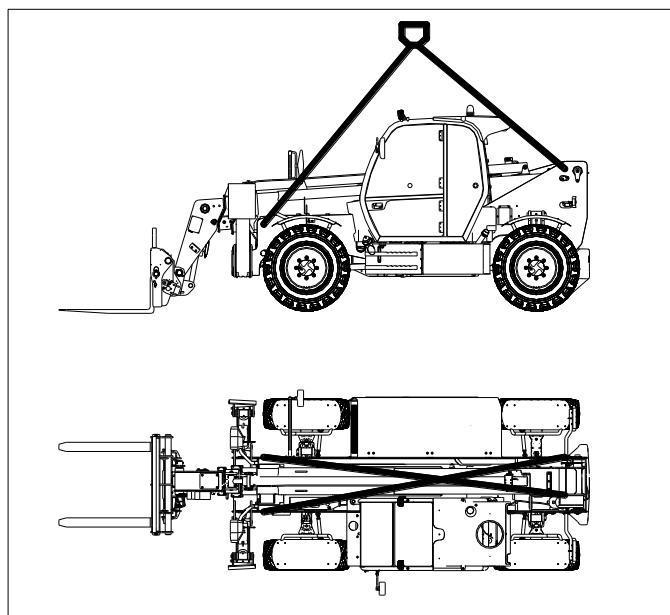

**Figure 6-1 Machine lifting diagram**

**⚠ WARNING**

Before lifting, make sure the rope is strong enough to support the vehicle.

### 6.1.2 Flat-bed trailer transportation

Machines can use the flatbed carrier as a tool for long-distance transportation.

**⚠ DANGER**

**An operator must not operate the machine, only if:**

**You have understood and practiced the rules in this operating manual for the safe operation of the vehicle.**

- (1) Prepare the flat-bed trailer

When loading, make sure the ramp is in place and the access is clear of obstacles.

- (2) Check before starting

Perform operations according to the steps in "Check before Starting" in the Operation Manual.

- (3) Check before moving

Perform the operation according to the steps in "Check before moving" in the Operation Manual.

- (4) Loading

If backing the vehicle onto the flatbed, use reverse gear. If moving forward onto a flatbed, use forward gear.

- (5) Fix the machine

To prevent the vehicle from moving, make sure that the front and rear wheels are jammed with diagonal wood or chained to the correct position.

- (6) Unload

Unloading process, as opposed to loading sequence.



It is prohibited to drive the machine onto a bearing platform without the following checks:

- a) a) Ensure that the position is reasonable and can speed up travel.
- b) b) Ensure that the attached device (truck, truck, etc.) does not move.
- c) c) Ensure that the platform is suitable for the total weight of the vehicle to be loaded
- d) d) Ensure that the platform is fit for the machine.

## 6.2 Storage condition

The ambient temperature under the conditions of equipment storage and transportation is  $-40^{\circ}\text{C} \sim 50^{\circ}\text{C}$ , the relative humidity is not more than 85%, and the short-term allowed to reach 100%.

If you have not used your vehicle for more than 6 months, follow these steps:

- A. Remove contaminants from the machine.
- B. Completely retract all cylinders.
- C. Remove the battery and put it in a dry place with good air flow. Regular charging (once every half month) and discharging (once every three months).
- D. Fill up the tank.
- E. Fill the coolant tank.
- F. All exposed metal parts must be lubricated to prevent corrosion.
- G. Place the vehicle in the garage. If not, put a tarp over it to prevent corrosion. In rainy areas, machines should be inspected frequently to prevent corrosion. Protect the machine in very cold weather conditions.
- H. Run the engine for 15-30 minutes per month. Idling check each mechanism to ensure normal operation.
- I. Ensure that there is one person performs maintenance on the machine.
- J. If the vehicle is not operated for three months:  
Run the engine at idle speed for one hour at three month intervals.
- K. If the vehicle has not been operated for more than 18 months:
  - Keep the machine clean and maintained regularly.
  - Replace the aging sealing components.
  - Do a complete check of the engine to see if coolant, oil, and air filters need to be replaced.

# **ZOOMLION**

## **Telehandler Operation Manual**

### **Section 7 TECHNICAL PARAMETERS**

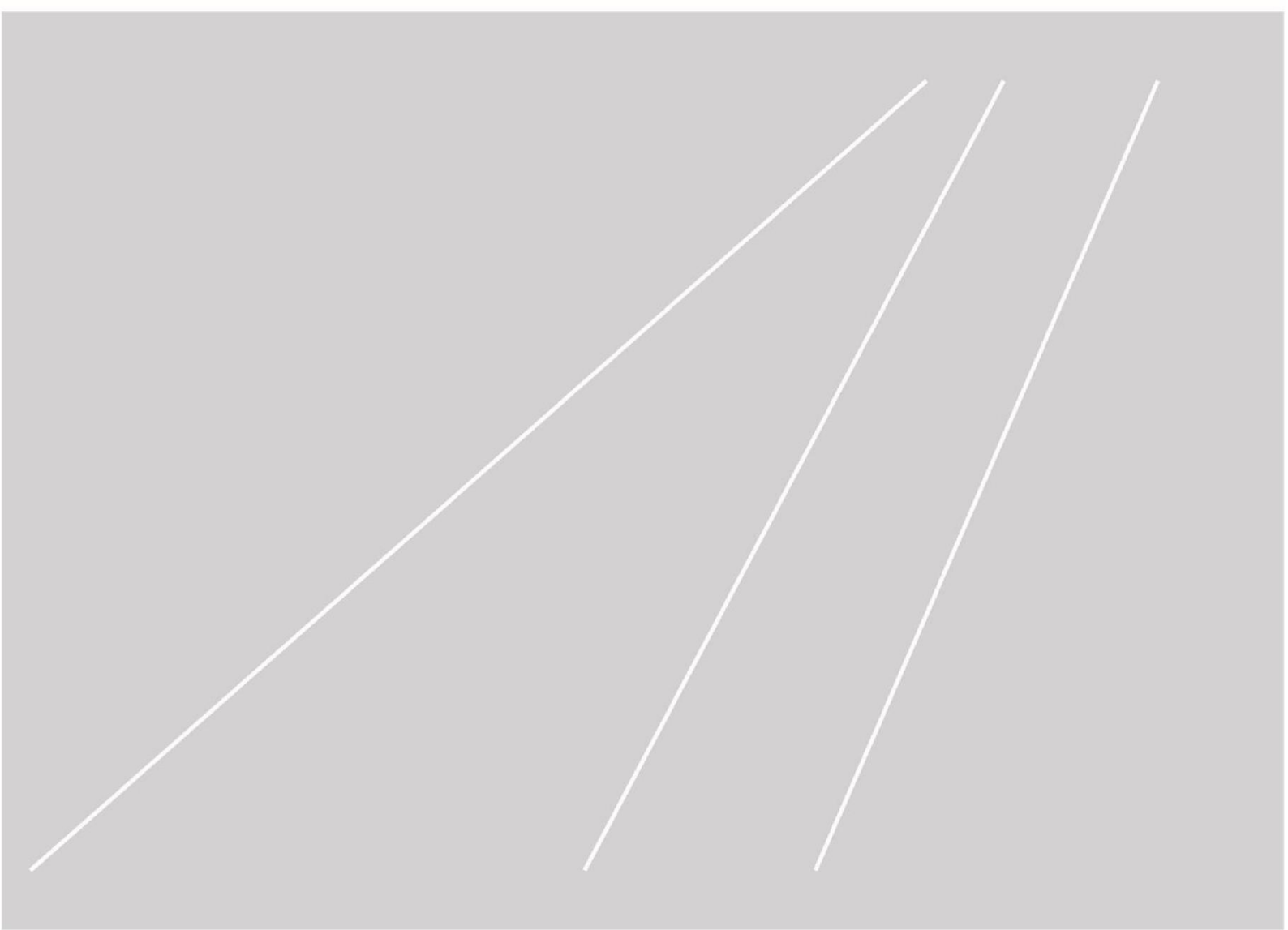



## SECTION SEVEN TECHNICAL PARAMETERS

Table 7-1 ZTH4014 telehandler parameters

Model	ZTH4014	
<b>Size</b>	Stowed length	6.31 m
	Stowed width	2.28 m
	Stowed height	2.57m
	Wheelbase	3.07 m
	Min ground clearance	0.42 m
<b>Performance</b>	Rated load	4000kg
	Max lifting height	13.8m
	Max capacity when lifted	3000kg
	Max reach	9.3m
	Max capacity when extended	1500kg
	Gross weight	11800kg
	Max traction force	72kN
	Frame leveling angle	±10°
	Rotating radius (outside)	3.8 m
<b>Power</b>	Engine brand/model	Cummins QSF 3.8 /Cummins F 3.8
	Rated power	74/55kW
	Max torque	420/ 400Nm
	Cylinder	4
	Displacement	3760 ml
	Transmission mode	Hydrostatic
	Max traveling speed	30/25 km/h
	Steering mode	Front wheels/4WS/Crab
<b>Tire</b>	Tire type	400/80R24
<b>Hydraulic</b>	Working pump type	Piston pump
	Hydraulic flow-pressure	135 L/min -280 bar
<b>Tank</b>	Fuel tank	140 L
	Fuel tank	145 L
<b>Fork</b>	Fork size	1220×122×50 mm
	Fork rotating angle	126 °
<b>Working speed</b>	Max lifting speed	17.5/13s
	Max extending speed	16.5/15 s
	Fork lifting speed	5 s
	Fork retracting speed	5 s

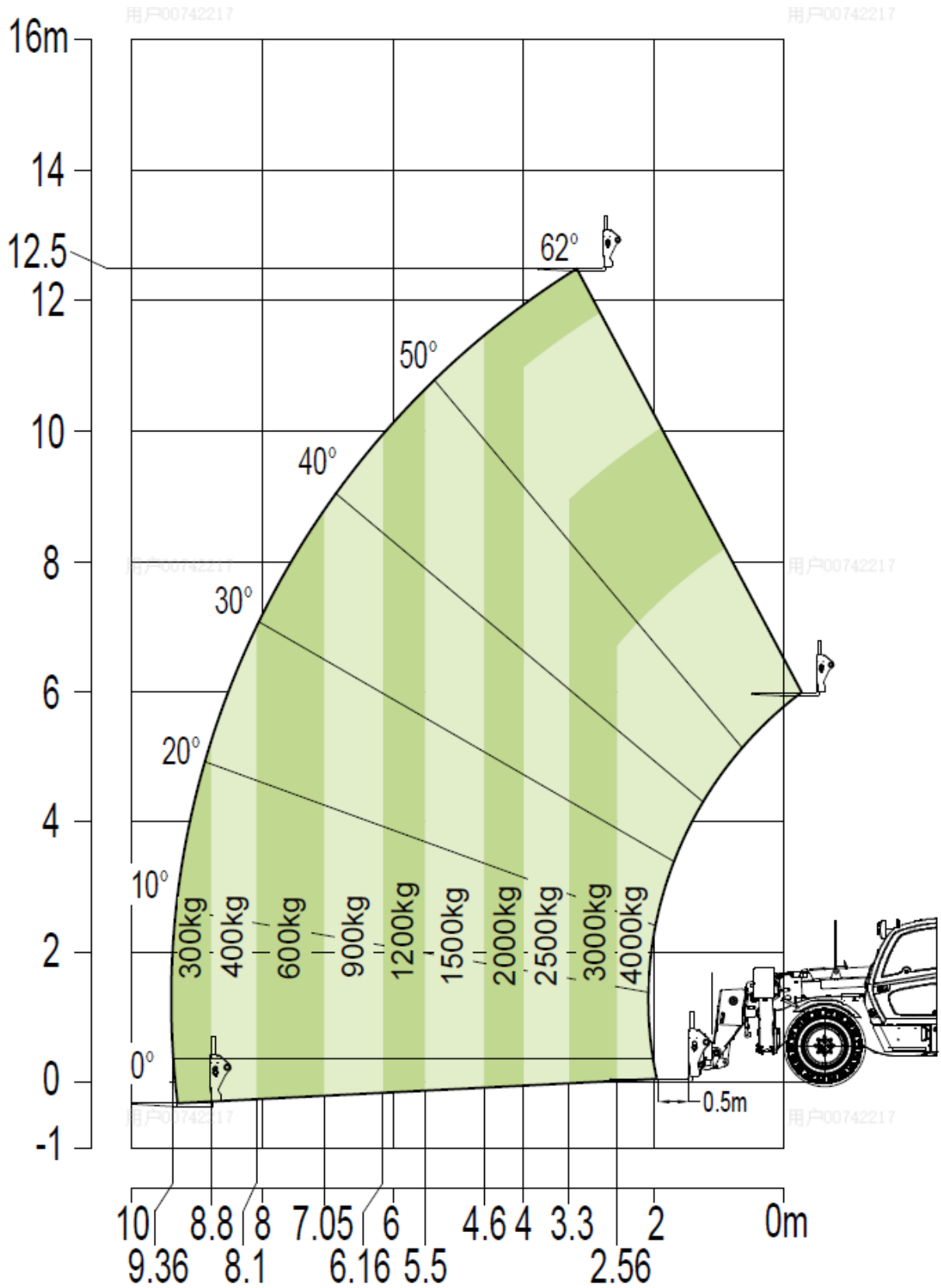

Figure 7-1 ZTH4014 work envelope (with tire)

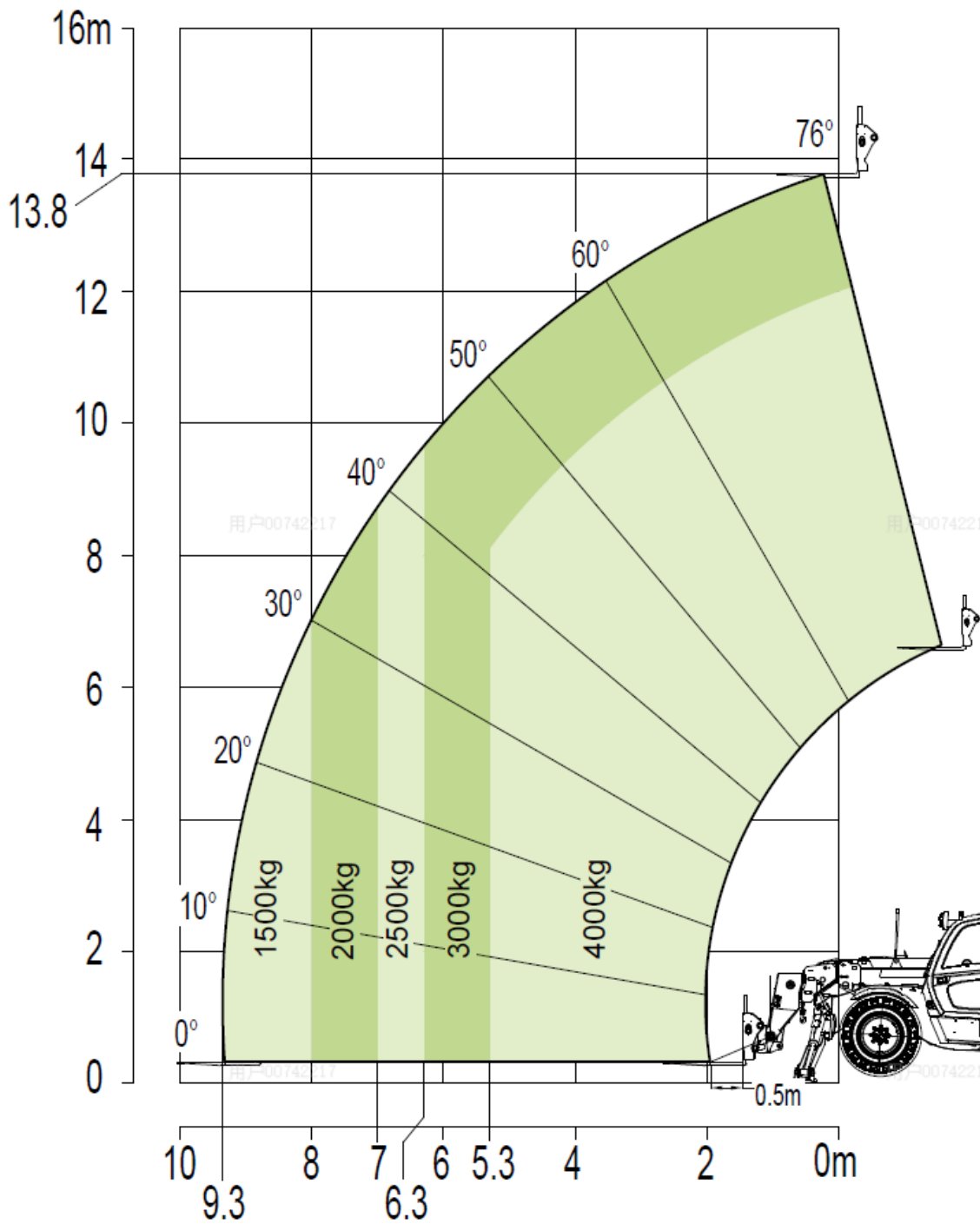
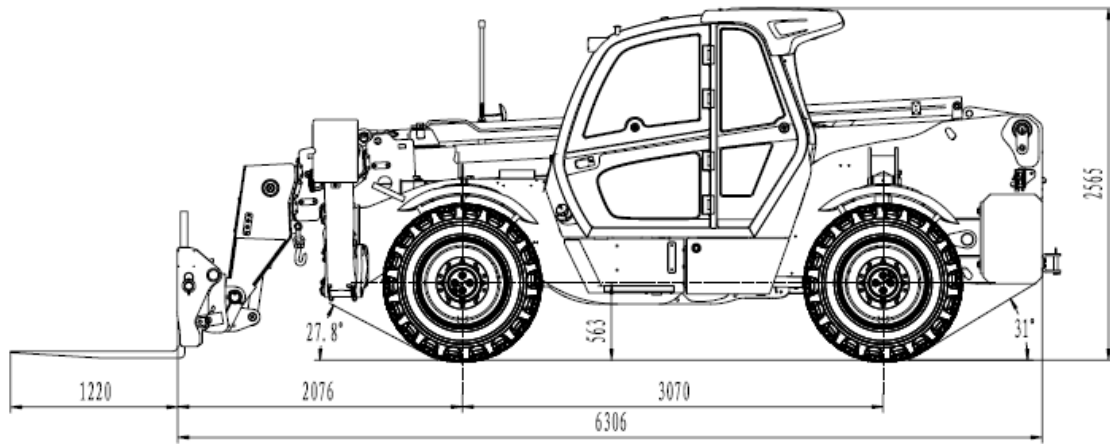

Figure 7-2 ZTH4014 work envelope (with Outrigger)

TECHNICAL  
PARAMETER



用戶00742217

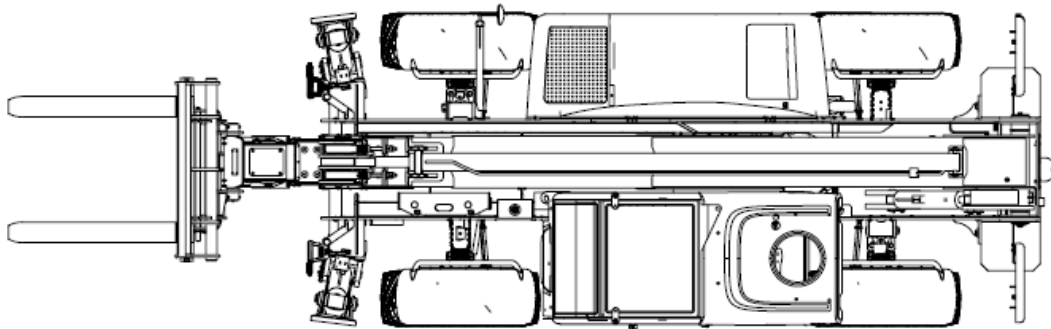

Figure 7-3 ZTH4014 size- stowed