

**ZOOMLION**

ZMP04

ZMP05

ZMP06

Operation and safety manual

March 2025 Version C



## Preface

Zoomlion appreciates your choice of our machine for your application. The Operation and Safety Manual must be read and understood in its entirety before operating the machine.

This manual introduces you safety information, significant technical specs, safety operation in detail for working efficiency improving. Keep this manual properly at all times for looking up.

Do not operate the machine if there is any doubt in operation, please consult local service team for troubleshooting. Zoomlion Intelligent Access Machinery Co., Ltd. does not take the consequence of wrong operation. Zoomlion Intelligent Access Machinery Co., Ltd. does not take the consequence of wrong operation.

This manual should be considered a permanent part of your machine and should remain with the machine at all times.

The content is under intellectual property protection, permission is required for a copy or other application.

There might be some tiny differences in details between your machine and the upgraded one due to the continuous improving. For clarification, questions, or additional information regarding any portions of this manual, contact local service team.

Our company reserves the right to modify this manual as technical improvement without notice.

Thank you for your trust and support for Zoomlion products!

Zoomlion Intelligent Access Machinery Co., Ltd

## Safety Precaution Icons

This manual has the following safety precaution icons:

**⚠ DANGER**

Failure to comply with the safety precautions listed in this manual could result in personal injury or death.

**⚠ WARNING**

Failure to comply with the safety precautions listed in this manual could result in potential personal injury or death.

**⚠ CAUTION**

Failure to comply with the safety precautions listed in this manual could result in potential mild personal injury.

**NOTICE**

Indicates risks unrelated with personal injury (such as property damage).

## Contents

<b>Preface.....</b>	<b>I</b>
<b>Safety Precaution Icons .....</b>	<b>II</b>
<b>Contents .....</b>	<b>III</b>
<b>SECTION 1 SAFETY PRECAUTIONS .....</b>	<b>1-1</b>
1.1 General.....	1-1
1.2 Pre-operation cautions .....	1-1
1.3 Hazard Classification .....	1-2
1.4 Intended use .....	1-2
1.5 Safety Alert Symbols and Maintenance .....	1-2
1.6 Safety Operation .....	1-5
1.6.1 Operator safety.....	1-5
1.6.2 Workplace safety.....	1-5
1.6.2.1 Electric shock hazard.....	1-5
1.6.2.2 Tilting over hazard.....	1-6
1.6.2.3 Crushing hazard.....	1-9
1.6.2.4 Danger of operation on slopes .....	1-9
1.6.2.5 Fall hazard .....	1-10
1.6.2.6 Collision hazard.....	1-10
1.6.2.7 Burn Hazard.....	1-12
1.6.2.8 Explosion and Fire Hazards.....	1-12
1.6.2.9 Machine Damage.....	1-13
1.6.2.10 Component Damaged Hazard.....	1-13
<b>SECTION 2 MACHINE COMPONENTS AND CONTROLS.....</b>	<b>2-1</b>
2.1 Machine Components .....	2-1
2.2 Machine controller.....	2-3
2.2.1 ZMP06/ZMP04 ground controller .....	2-3
2.2.2 ZMP05 Ground control console.....	2-4
2.2.3 ZMP06/ZMP05/ZMP04 platform controller .....	2-5
<b>SECTION 3 MACHINE INSPECTION .....</b>	<b>3-1</b>
3.1 General.....	3-1
3.1.1 Pre-Start Inspection Principle .....	3-1
3.1.2 Pre-Start Inspection.....	3-1

## Contents

3.2 Function Test.....	3-3
3.2.1 Function test principle .....	3-3
3.2.2 Open power main switch .....	3-3
3.2.3 Ground function check.....	3-3
3.2.4 Platform function check.....	3-4
3.2.5 Turning Off the Main Power Switch.....	3-8
3.3 Workplace Inspection.....	3-8
3.3.1 Basic Principles of workplace inspection .....	3-8
3.3.2 Workplace inspection.....	3-8
3.4 Decal Inspection .....	3-10
<b>SECTION 4 OPERATION INSTRUCTION.....</b>	<b>4-1</b>
4.1 General.....	4-1
4.2 Basic Operation.....	4-1
4.2.1 Open or close power main switch.....	4-1
4.2.2 Emergency stop.....	4-2
4.2.3 Emergency lowering .....	4-2
4.2.4 Post-use operation.....	4-2
4.3 Ground console operation .....	4-2
4.3.1 Activate ground console.....	4-2
4.3.2 Adjust platform position .....	4-2
4.4 Platform operation .....	4-3
4.4.1 Activate platform console .....	4-3
4.4.2 Adjust platform position .....	4-3
4.4.3 Steering.....	4-3
4.4.4 Driving.....	4-4
4.4.5 Drive speed selection .....	4-4
4.4.6 Platform AC power (AC 220V).....	4-5
4.4.7 Indoor and outdoor working mode selection .....	4-6
4.5 Slope Operation .....	4-10
4.5.1 Drive on slopes .....	4-10
4.5.2 Work on slope .....	4-11
4.6 Traction.....	4-11
4.7 Operation Code .....	4-15
4.7.1 Operation Indicator Code.....	4-15

## Contents

4.7.2 Platform overload .....	4-15
4.7.3 Battery capacity indicator .....	4-16
4.8 Battery and Charger Operation .....	4-16
4.8.1 Matters to be observed.....	4-16
4.8.2 Charge the battery .....	4-16
4.8.3 Maintenance free battery .....	4-17
4.8.4 Standard Battery .....	4-17
4.8.5 Dry Battery filling and charging instructions .....	4-17
4.9 Li-ion battery and Charger Operation .....	4-17
4.9.1 Matters to be observed.....	4-17
4.9.2 Charge the li-battery .....	4-18
4.10 Transport and Lifting .....	4-18
4.10.1 Matters to be observed.....	4-18
4.10.2 Transportation Operations.....	4-19
4.10.3 Lifting operation .....	4-21
<b>SECTION 5 MAINTENANCE.....</b>	<b>5-1</b>
5.1 General.....	5-1
5.1.1 Maintenance Symbols Legend.....	5-1
5.1.2 Pre-Start Inspection.....	5-1
5.1.3 Maintenance hazards.....	5-2
5.1.4 Body injury hazard.....	5-2
5.2 Hydraulic system maintenance .....	5-3
5.2.1 Check hydraulic oil level .....	5-3
5.2.2 Hydraulic oil capacity .....	5-3
5.2.3 Hydraulic Oil Specification .....	5-4
5.2.4 Hydraulic Oil Viscosity and Temperature Limit .....	5-5
5.2.5 Changing Hydraulic Oil.....	5-6
5.2.6 Changing Oil Return Filter .....	5-6
5.3 Battery Maintenance .....	5-6
5.4 Regular Maintenance .....	5-7
<b>SECTION 6 STORAGE AND EX-FACTORY TEST.....</b>	<b>6-1</b>
6.1 Storage Conditions.....	6-1
6.2 Ex-factory Test Items .....	6-1

---

## Contents

---

<b>SECTION 7 TECHNICAL PARAMETERS .....</b>	<b>7-1</b>
<b>DISPOSAL .....</b>	<b>a</b>
<b>APPENDIX:INSPECTION AND MAINTENANCE RECORD.....</b>	<b>b</b>

# **ZOOMLION**

Operation and Safety Manual

Section 1 Safety Precautions





## SECTION 1 SAFETY PRECAUTIONS

### 1.1 General

To Owners/Users/Operators:

Zoomlion appreciates your choice of our machine for your application. We put operator safety at the first place, and it is best achieved by our joint efforts. The following requirements need to be adhere to for the purpose of safety operating:

- a) Obey all user rules, job site regulations and governmental regulations.
- b) Read, understand and obey all operating instructions on the machine and in this manual.
- c) Keep good safety operating conventions.
- d) Allow only those authorized and qualified personnel to operate the machine under the supervision of an experienced and qualified operator.
- e) An operator must not operate the machine if he has any doubts.

Zoomlion appreciates your choice of our machine for your application.

### 1.2 Pre-operation cautions

#### **⚠ DANGER**

Failure to comply with the safety precautions listed in this manual could result in personal injury or death.

An operator must not operate the machine, only if:

- a) He has learned and practiced the principles of safe machine operation contained in this operational manual;
  - 1) Avoid hazardous situations;
  - 2) Be aware of safety rules before further operation;
  - 3) Perform a pre-operation inspection at all times;
  - 4) Implement functional test before operating the machine at all times;
  - 5) Inspect job site;
  - 6) Only use the machine as it was intended.
- b) Read, understand and obey the manufacturer's instructions and safety rules—safety and operator's manuals and machine decals;
- c) Read, understand and obey employer's safety rules and work site regulations;

- d) Read, understand and obey all applicable governmental regulations;
- e) The operator is properly trained to safely operate the machine.

### 1.3 Hazard Classification

Decals on this machine use symbols, color coding, and signal words to identify the following:



Safety alert symbol—used to alert you to potential personal injury hazards. Obey all safety messages that follow this symbol to avoid possible injury or death.

#### **▲ DANGER**

Indicates a hazardous situation which, if not avoided, will result in death or serious injury. This decal will have a red background.

#### **▲ WARNING**

Indicates a hazardous situation which, if not avoided, could result in death or serious injury. This decal will have an orange background.

#### **▲ CAUTION**

Indicates a hazardous situation which, if not avoided, could result in minor or moderate injury. This decal will have a yellow background.

#### **NOTICE**

Indicates a property damage message. This decal will have a blue background.

### 1.4 Intended use

This machine is intended to be used only to lift personnel, along with their tools, and materials to an aerial work site.

### 1.5 Safety Alert Symbols and Maintenance

Replace any missing or damaged safety signs. Operator must keep safety awareness in mind at all times. Use mild soap and water to clean safety signs. Do not use solvent-based cleaners because they may damage the safety sign material. Do not use solvent-based cleaners because they may damage the safety sign material.



















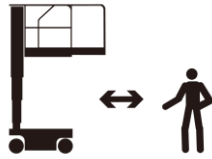
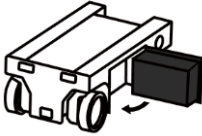
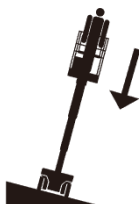

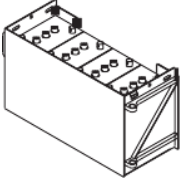

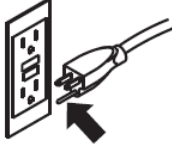
				
Read Operation and Safety Manual	Read Maintenance Manual	Crushing hazard	Crushing hazard	Collision hazard
				
Tip-over hazard	Tip-over hazard	Tip-over hazard	Tip-over hazard	Electrocution hazard
				
Electrocution hazard	Explosion Hazard	Fire Hazards	Burn hazard	Dermohemia hazard
				
Engaging safety arm	Away from running parts	Away from outrigger and tire	Move the machine to a flat ground	Close chassis tray
				
Lower platform	Do not assemble in a place that the outrigger cannot reach	Keep required clearance	Only trained maintenance personnel are allowed to inspect compartments.	Use a piece of paperboard or a piece of paper to check leakage

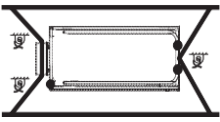
Figure 1-1 Symbol and Hazard Pictorials Definitions

				
Battery as counterweight	Wedge the wheel	Release brake	3-wire ground only AC power	Replace damaged wires and cables
				
Wheel load	Transportation diagram	Tie point	Lanyard anchorage points.	No smoking.
				
Rated voltage of the platform power supply	Pressure rating of the air line to the platform	Manual force	Wind speed	
				
Maximum platform capacity	Outdoor		Indoor	

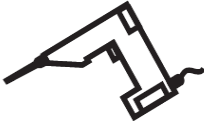
**Figure 1-1 Symbol and Hazard Pictorials Definitions (cont.)**

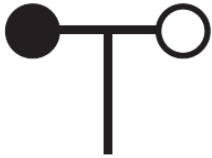
## 1.6 Safety Operation

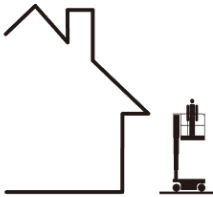
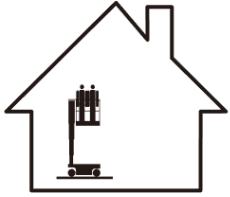
### 1.6.1 Operator safety

Personal fall protection equipment (PFPE) is required when operating this machine. If PFPE is required in the workplace or in the rules of use, the following rules apply.

All PFPE must comply with applicable governmental regulations, and must be inspected and used in accordance with the PFPE manufacturer’s instructions.

### 1.6.2 Workplace safety

#### 1.6.2.1 Electric shock hazard

**⚠ DANGER**

This machine is not electrically insulated and will not provide protection from contact with or proximity to electrical current.

- a) Obey all local and governmental regulations regarding required clearance from electrical power lines. At a minimum, the required clearance contained in the chart below must be followed.



**Table 1-1 Required Clearance**

No.	No. Line Voltage	Required Clearance
1	0 to 50KV	3.05 m/10 ft
2	50 to 50KV	4.60 m/15 ft
3	200 to 50KV	6.10 m/20 ft
4	350 to 50KV	7.62 m/25 ft
5	500 to 50KV	10.67m/35 ft
6	750 to 1000KV	13.72m/45 ft

- b) Allow for platform movement, electrical line sway or sag, and beware of strong or gusty winds.
- c) Keep away from the machine if it contacts energized power lines. Personnel on the ground or in the platform must not touch or operate the machine until energized power lines are shut off.



Do not operate the machine during lightning or storms.

Do not use the machine as a ground for welding.

### 1.6.2.2 Tilting over hazard

#### **⚠ DANGER**

- a) Occupants, equipment and materials shall not exceed the maximum platform capacity.

**Table 1-2 Rated Load**

Model	Maximum platform capacity	Maximum extension platform capacity
ZMP06	200 kg/440 lbs	113 kg/250 lbs
ZMP05	230 kg/510 lbs	113 kg/250 lbs
ZMP04	230 kg/510 lbs	113 kg/250 lbs

- b) Do not raise the platform unless the machine is on a firm, level surface.

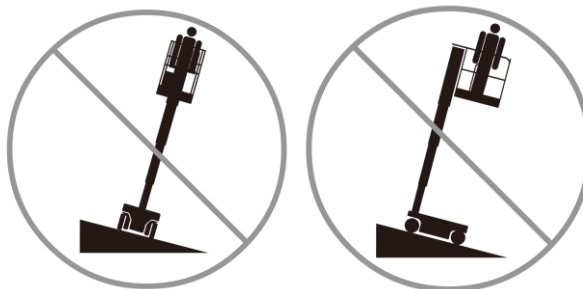

- c) Do not use the tilt alarm as a level indicator. The tilt alarm sounds in the chassis only when the machine is on a severe slope.

If the tilting alarm sounds: Lower the platform using the emergency lowering pull rod. Be very careful when lowering the platform. Move the machine to a solid level ground before lifting.

d) The driving speed should not exceed 0.8km/h(0.5mph) when the platform is raised;

Outdoor use: Do not raise the platform when wind speeds may exceed 12.5 m/s (28mph). If the wind speed exceeds 12.5m/s (28mph) after the platform is raised, lower the platform and do not continue to operate the machine;

Indoor use: When lifting the platform, follow the allowable manual force and number of personnel listed in Table 1-3.

**Table 1-4 Maximum allowable manual force**

Model	Manual force	Maximum occupants
ZMP06	200 N/45 lbs force	1 (Indoor only)
ZMP05	200 N/45 lbs force	1 (Indoor)/1 (Outdoor)
ZMP04	400N/200N 90 lbs/45 lbs force	2 (Indoor)/1 (Outdoor)

e) Do not operate the machine in strong or gusty winds. Do not increase the surface area of the platform or the load. Increasing the area exposed to the wind will decrease machine stability.

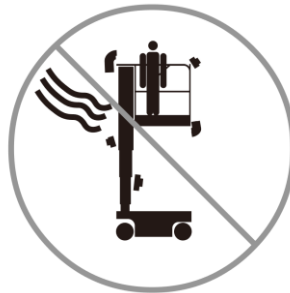

f) Be extreme careful and keep slow speeds while driving the machine in the stowed position across uneven terrain, debris, soft or slippery surfaces and near holes or drop-offs.



g) Do not drive the machine on or near uneven terrain, unstable surfaces or other hazardous conditions with the platform raised or extended.

- h) Under any circumstances, the following violations are prohibited:
- 1) To propel a machine or other object with a platform;
  - 2) Make the platform contact with adjacent components;
  - 3) The platform is bound to adjacent components;
  - 4) Placing loads outside the perimeter of the platform;
  - 5) Operate the machine while the chassis bracket is open;
  - 6) Push and pull any object outside the platform.



- i) Do not modify or alter an aerial work platform without prior written permission from the manufacture.
- 1) Do not change or prohibit the use of the limit switch;
  - 2) Do not alter or disable machine components that in any way affect safety and stability.
  - 3) Do not replace items critical to machine stability with items of different weight or specification.
  - 4) Do not install additional devices for placing tools or other materials on the platform, toe plate or guard rail, which will increase the weight and surface area of the platform or increase the load.
- j) Do not use batteries that weigh less than the original battery or lithium battery. The battery acts as a counterweight and is essential for maintaining the stability of the machine:
- 1) For the ZMP06 machine, each lithium battery must weigh up to 36 kg/79 lbs. The minimum weight of each battery carrier (including the battery) must be 53 kg/117 lbs;
  - 2) For ZMP05 machines, each battery must weigh up to 36kg/79 lbs.
  - 3) For ZMP04 machines, each battery must weigh up to 36kg/79 lbs. The minimum weight of each battery carrier (including the battery) must be 53 kg/117 lbs;
- k) Do not place or attach fixed or overhanging loads to any part of this machine.
- l) Do not place ladders or scaffolds in the platform or against any part of this machine.



- m) Do not transport tools and materials unless they are evenly distributed and can be safely handled by person(s) in the platform.
- n) Do not use the machine on moving or active surfaces or vehicles. Make sure all tires are in good condition, that the grooved nuts are properly tightened and that the open pins are properly installed.

### 1.6.2.3 Crushing hazard

#### **⚠ DANGER**

- a) Keep your hands and arms away from areas where there is a risk of cutting.
- b) Do not work under the platform or outside the mast when the safety arm is not in proper position;
- c) When using the controller to operate the machine on the ground, Keep a clear mind. Maintain a safe distance between operator, machine and fixed objects.

### 1.6.2.4 Danger of operation on slopes

#### **⚠ DANGER**

Do not drive the machine on slopes that exceed the machine's longitudinal and lateral ratings. Longitudinal and lateral ratings are for machines in the stow position.

**Table 1-4 Vertical and lateral ratings of the collapse state**

Model	Maximum vertical rating of the stowed state	Maximum lateral rating of the stowed state
ZMP06	25% (14°)	25% (14°)
ZMP05	25% (14°)	25% (14°)
ZMP04	25% (14°)	25% (14°)

### 1.6.2.5 Fall hazard

#### **⚠ DANGER**

Guardrail system provides fall protection. If workplace or user rules require personnel on the platform to use a Personal fall Protection device (PFPE), the PFPE should be used in accordance with the PFPE's manufacturer's instructions and applicable government requirements. Tie the lanyard to the anchor point of the platform.

- a) Do not sit, stand or climb on the platform guard rails. Maintain a firm footing on the platform floor at all times.
- b) Do not climb down from the platform when raised.



- c) Keep the platform floor free of debris;
- d) Do not enter or exit the platform unless the machine is in the fold position;
- e) Connect the platform entrance chain or close the entrance door before operation;
- f) If the guard rail is not properly installed and the entrance cannot be safely operated, do not operate the machine.

### 1.6.2.6 Collision hazard

#### **⚠ DANGER**

No stunt driving or horseplay while operating a machine.

- a) Be aware of limited sight distance and blind spots when driving and operating.

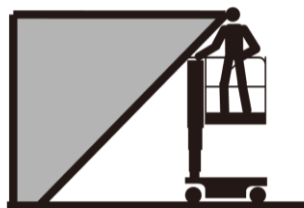

- b) Note the position of the platform extension when moving the machine;
- c) Be sure the machine is on a level surface or secured before releasing the brake.
- d) Users must comply with user rules, workplace rules and government rules governing the use

of personal protective equipment.

- e) Check the working area for overhead obstacles or other possible dangers;



- f) Beware of the risk of crushing when holding onto the platform guardrail;



- g) Observe and use the directional arrows of the driving and steering function on the platform controller and the platform label nameplate;

- h) The platform can only be lowered when the area below the platform is free of personnel and obstacles;



- i) Limit travel speed according to the condition of the ground surface, congestion, slope, location of personnel, and any other factors which may cause collision.



- j) Do not operate machinery on the route of any crane or moving overhead machinery unless the crane controller is locked or precautions have been taken to prevent any potential collision.

### 1.6.2.7 Burn Hazard

#### **⚠ DANGER**

- a) Liquid or gas burn risk;
  - 1) Do not operate a machine with a hydraulic oil or air leak. An air leak or hydraulic leak can penetrate and/or burn skin;
  - 2) Batteries contain acidic substances. Always wear protective clothing and eye wear when working with batteries.



- 3) Avoid leakage of acidic substances from batteries or contact with them. Use soda and water to neutralize spilled battery acid.
  - 4) Do not expose the battery or charger in water or rain while charging.

#### **⚠ DANGER**

- b) Danger of electric shock or burn.
  - 1) Conduct daily check with wires and cables.



- 2) Change damaged items prior to operation. Avoid contact with battery terminals. Remove all rings, watches and other accessories.
  - 3) Only connect the charger and platform AC power plug (if equipped) to a grounded three-wire AC power outlet.

### 1.6.2.8 Explosion and Fire Hazards

#### **⚠ DANGER**

- a) Do not charge the battery in hazardous locations where potentially flammable or explosive

gases or particles may be present.

- b) Keep sparks, flames, and lighted tobacco away from batteries. Batteries emit explosive gas.



- c) The charger tray can be opened during indoor charging to facilitate heat dissipation;
- d) Do not use tools which could produce flames to contact battery terminals or cable clamp.
- e) Li-battery Not close to high temperature heat source;
- f) Li-battery Overcharge and overdischarge are strictly prohibited in the system.
- g) Li-battery In the process of use, if there is heat, deformation, leakage, odor or smoke, you must immediately stop using the battery, and put the battery in an open place away from people;
- h) It is strictly prohibited to immerse the lithium battery in water, acidic, alkaline and saline solutions to avoid rain.

### 1.6.2.9 Machine Damage

#### **⚠ DANGER**

- a) Do not use a damaged or malfunctioning machine. Conduct a thorough pre-operation inspection of the machine and test all functions before each work shift.
- b) Immediately tag and remove from service a damaged or malfunctioning machine.
- c) Be sure all maintenance has been performed as specified in this manual and the appropriate Zoomlion service manual;
- d) Be sure all decals are in place and legible;
- e) Be sure operator's, safety, and responsibilities manuals are complete, legible, and in the storage container located on the machine.

### 1.6.2.10 Component Damaged Hazard

#### **⚠ DANGER**

- a) Do not use a charger other than the ZOOMLION charger to charge the battery;
- b) When lifting a battery, use an appropriate number of people and lift the battery, and lock the battery after each use.



# ZOOMLION

Operation and Safety Manual

Section 2 Machine Components  
and Controls





## SECTION 2 MACHINE COMPONENTS AND CONTROLS

### 2.1 Machine Components

a) ZMP06/ZMP04 components

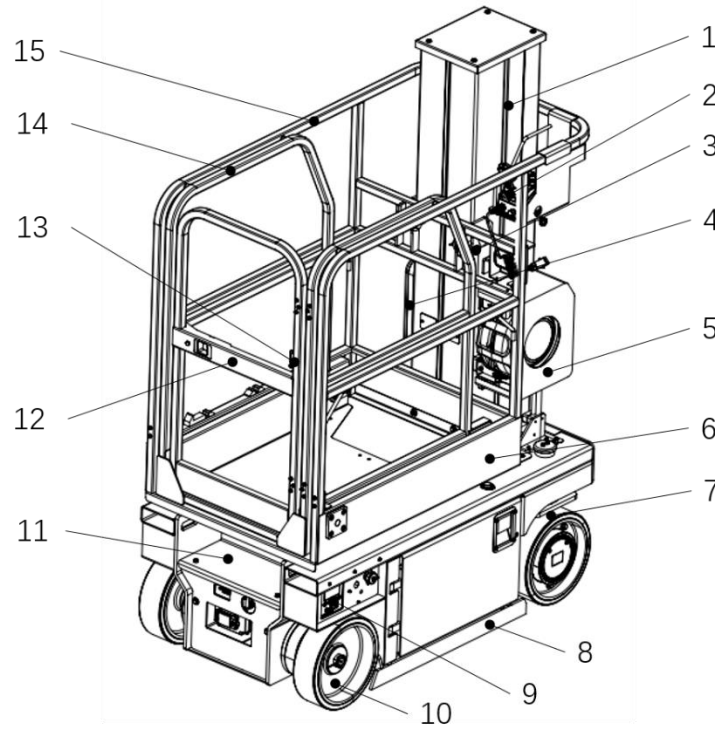
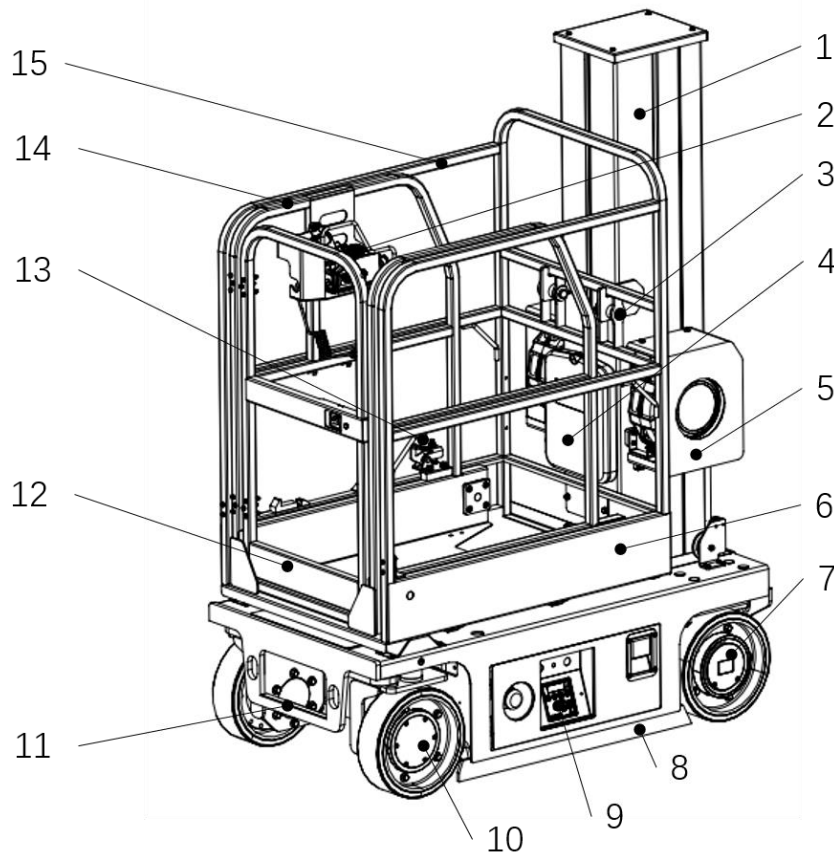

Figure 2-1 Components 1

Table 2-1 Component instruction

No.	Item	No.	Item	No.	Item
1	Mast	6	Fixed platform	11	Entrance ladder
2	Platform console	7	Steering wheel	12	Platform entrance gate
3	Platform anchorage point	8	Pothole protective device	13	Foot switch.
4	Manual storage box	9	Ground control	14	Extension deck
5	Winding roll	10	Non-steering wheel	15	Platform guardrail

b) ZMP05 Machine components



**Table 2-2 Component instruction 2**

**Table 2-2 Component instruction 2**

No.	Item	No.	Item	No.	Item
1	Mast	6	Fixed platform	11	Entrance ladder
2	Platform console	7	Drive wheel	12	Platform entrance gate
3	Platform anchorage point	8	Pothole protective device	13	Foot switch.
4	Manual storage box	9	Ground control	14	Extension deck
5	Winding roll	10	Steering wheel	15	Platform guardrail

## 2.2 Machine controller

### **CAUTION**

The manufacturer has no direct control over machine application and operation. The user and operator are responsible for conforming with good safety practices.

#### 2.2.1 ZMP06/ZMP04 ground controller

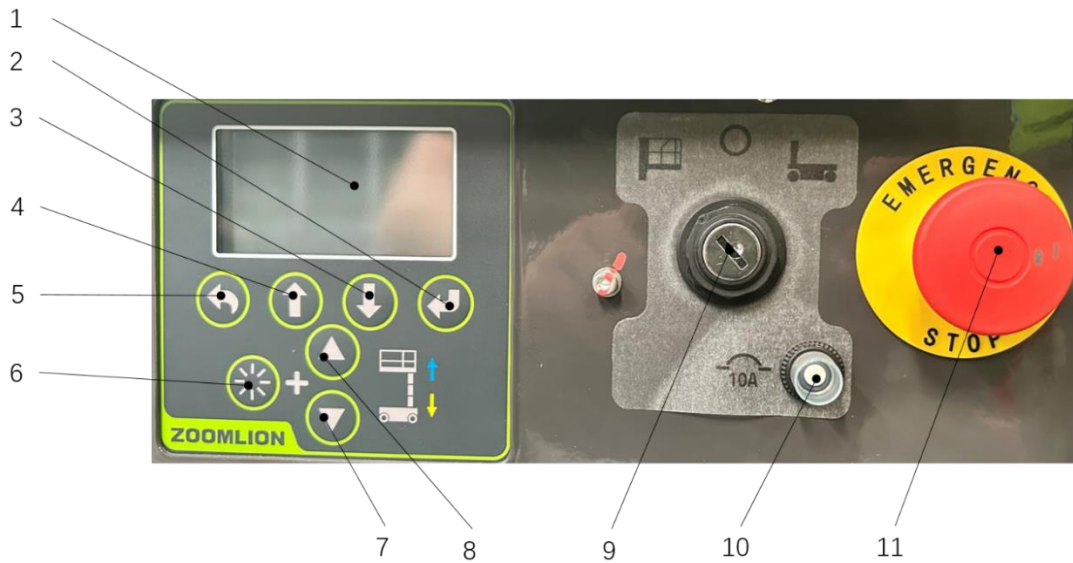

Figure 2-3 Ground control console

Table 2-3 Ground control console instruction

No.	Item	No.	Item
1	LCD diagnosis reading device	7	Platform lowering button
2	Menu enter button	8	Platform up button
3	Menu down button	9	Key switch
4	Menu up button	10	10A breaker
5	Menu exit button	11	Emergency stop switch
6	Lifting enable button		

a) Lifting enable button

Press this button to activate the platform lift function.

b) Key switch

Turn the key switch to the platform position and the platform controller will run. Turn the key switch to the off position and the machine will turn off. Turn the key switch to the ground position and the ground controller will run.

c) Emergency stop switch

Push the emergency stop switch inward to the off position to stop all functions. Pull the emergency stop switch to the on (on) position to operate the machine.

### 2.2.2 ZMP05 Ground control console



Figure 2-4 Ground control console

Table 2-4 Ground control console instruction

No.	Item	No.	Item
1	Key switch	7	LCD diagnosis reading device
2	10A breaker	8	Menu down button
3	Menu exit button	9	Menu enter button
4	Menu up button	10	Platform up button
5	Lifting enable button	11	Platform lowering button
6	Emergency stop switch		

a) Key switch

Turn the key switch to the platform position and the platform controller will run. Turn the key switch to the off position and the machine will turn off. Turn the key switch to the ground position and the ground controller will run.

b) Emergency stop switch

Push the emergency stop switch inward to the off position to stop all functions. Pull the emergency stop switch to the on (on) position to operate the machine.

**2.2.3 ZMP06/ZMP05/ZMP04 platform controller**



**Figure 2-5 Platform control panel**

**Table 2-5 Platform control panel instruction**

No.	Item	No.	Item
1	Emergency stop switch	5	Steering thumb button
2	Horn button	6	LED indicator
3	Lifting function button	7	Drive function button
4	Joystick	8	Drive speed button

a) Emergency stop switch

Push the emergency stop switch inward to the off position to stop all functions. Pull the emergency stop switch to the on (on) position to operate the machine.

b) Horn button

Press the horn button and the horn will sound. Release the horn button and the horn will not sound.



c) Lifting function button

Press this button to activate the lifting function. If no operation is performed after 7 seconds, press the button again to activate this function.

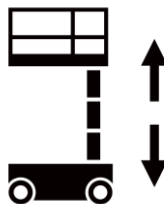

d) Proportional control handles and function enable switches for drive, steering and lifting functions;

Lifting function button First press the lift function button, then press and hold the function enable switch on the platform control lever to enable the lift function. Move the control joystick in the direction indicated by the blue arrow and the platform will rise. Move the control joystick in the direction indicated by the yellow arrow and the platform will drop. When the platform descends, the descent buzzer should sound.

Drive function button: First press the drive function button, then press and hold the function enable switch on the platform control lever to enable the drive function. Move the control joystick in the direction indicated by the blue arrow on the control panel, and the machine will move in the direction indicated by the blue arrow. Move the control joystick in the direction indicated by the yellow arrow on the control panel, and the machine will move in the direction indicated by the yellow arrow.

e) Steering thumb button for steering

Press the drive function button first, then press the left side of the thumb button, and the machine will turn in the direction indicated by the blue triangle on the platform control panel. Press the right side of the thumb button and the machine will turn in the direction indicated by the yellow triangle on the platform control panel.



f) LED indicator for battery level display and operation instruction code display;

g) Drive function button

Press this button to activate the driver function. If no operation is performed after 7 seconds, press the button again to activate this function.

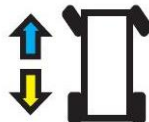

h) Drive speed button

Press this button to activate the slow drive function. When driving slowly, the indicator light will light up. This feature should be selected in drive mode.





# ZOOMLION

Operation and Safety Manual

Section 3 Machine Inspection

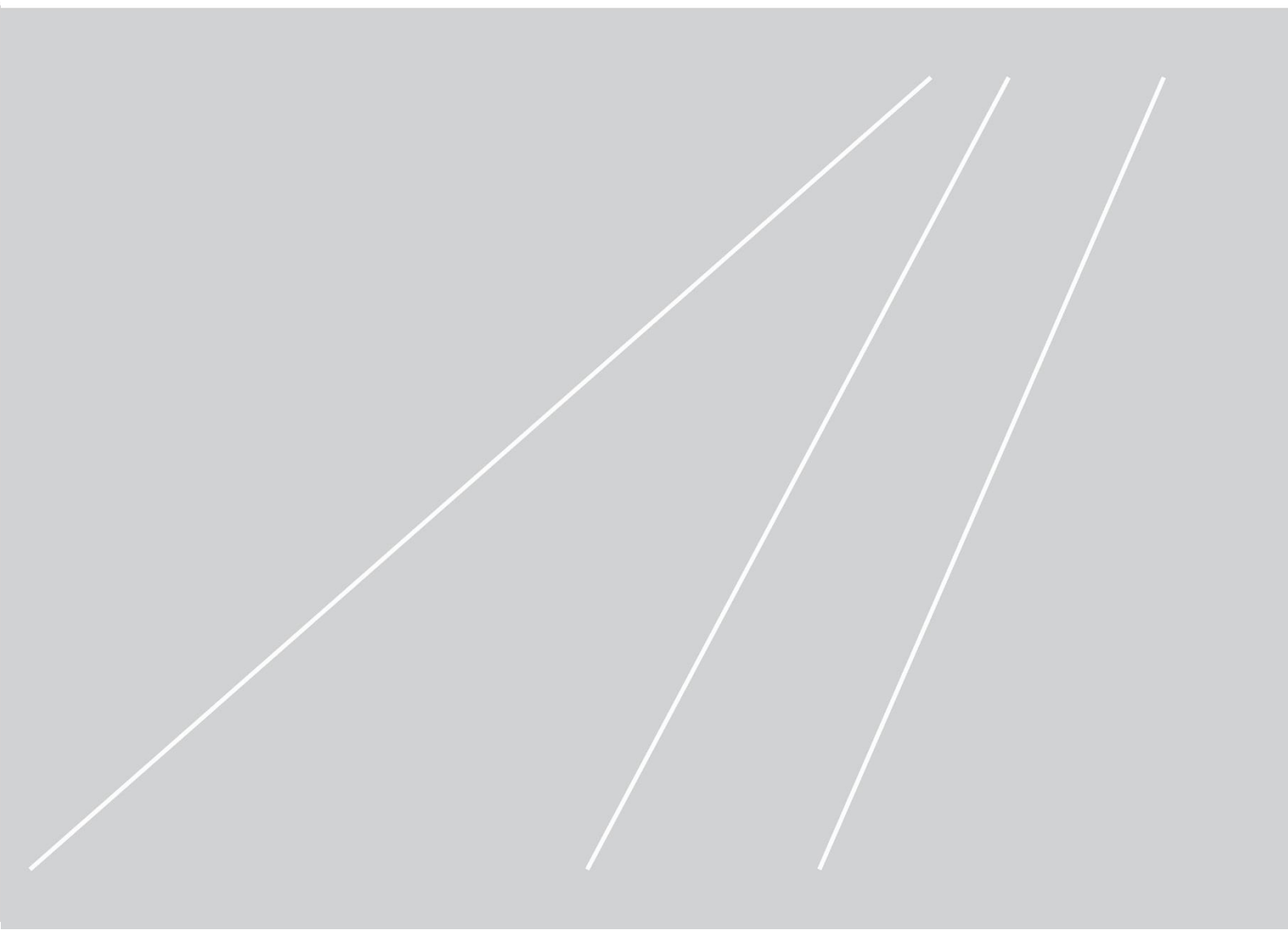



## SECTION 3 MACHINE INSPECTION

### 3.1 General

#### **⚠ DANGER**

An operator must not operate the machine, only if:

He has learned and practiced the principles of safe machine operation contained in this operational manual.

- a) Avoid hazardous situations;
- b) Perform a pre-operation inspection at all times;

Know and understand the pre-operation inspection before going on to the next section.

- c) Implement functional test before operating the machine at all times;
- d) Inspect job site;
- e) Only use the machine as it was intended.

#### 3.1.1 Pre-Start Inspection Principle

- a) It is the responsibility of the operator to perform a pre-operation inspection and routine maintenance.
- b) The pre-operation inspection is a visual inspection performed by the operator prior to each work shift. The inspection is designed to discover if anything is apparently wrong with a machine before the operator performs the function tests.
- c) The pre-operation inspection also serves to determine if routine maintenance procedures are required. Only routine maintenance items specified in this manual shall be performed by the operator.
- d) Refer to the list on the next page and check each of the items.
- e) If damage or any unauthorized variation from factory delivered condition is discovered, the machine must be tagged and removed from service.
- f) A malfunctioning machine must never be used. If malfunctions are discovered, the machine must be tagged and removed from service.
- g) After repairs are completed, the operator must perform a pre-operation inspection again before putting the machine into service. A malfunctioning machine must never be used.

### 3.1.2 Pre-Start Inspection

- a) Be sure operator's, safety, and responsibilities manuals are complete, legible, and in the storage container located on the machine.
- b) Be sure all decals are in place and legible. See Inspections section.
- c) Check for hydraulic oil leaks and proper oil level. Add oil if needed. See Inspections section.
- d) Check for engine oil leaks and proper oil level. Add oil if needed. See Inspections section.
- e) Check for engine coolant leaks and proper fluid level. Add coolant if needed. See Inspections section.
- f) Check the following components or areas for damage, improperly installed, or missing parts and unauthorized modifications:
  - 1) Electrical components, wiring, and electrical cables.
  - 2) Hydraulic hoses, fittings, cylinders, and manifolds.
  - 3) Drive motor;
  - 4) Wear pads;
  - 5) Tire and wheel;
  - 6) Engine and relevant components
  - 7) Alarm and indicator (if equipped).
  - 8) Nuts, bolts and other fasteners.
  - 9) Brake release unit;
  - 10) Oil absorbent cotton and magnet;
  - 11) Extension deck;
  - 12) Mast rivets and sliders;
  - 13) Platform control lever;
  - 14) Outrigger rack and foot pad (if equipped);
  - 15) Battery pack and connecting;
  - 16) Grounding belt;
  - 17) Platform entrance chain or door;
  - 18) Platform overload parts;
  - 19) Pit protection device;
  - 20) Lanyard anchorage points.

- 21) Check entire machine for:
- ① Cracks in welds or structural components.
  - ② Dents or damage to machine.
  - ③ Excessive rust, corrosion or oxidation.
- g) Be sure that all structural and other critical components are present and all associated fasteners and pins are in place and properly tightened.
- h) Be sure that batteries properly connect;
- i) After inspection, be sure that all covers are in place and latched.

**⚠ CAUTION**

Be sure that the safety arm is in proper place when raising the platform for maintenance. See Operating Instruction section.

## 3.2 Function Test

### 3.2.1 Function test principle

- a) The function tests are designed to discover any malfunctions before the machine is put into service. The operator must follow the step-by-step instructions to test all machine functions.
- b) A malfunctioning machine must never be used. If malfunctions are discovered, the machine must be tagged and removed from service. Repairs to the machine may only be made by a qualified service technician, according to the manufacturer's specifications.
- c) After repairs are completed, the operator must perform a pre-operation inspection again before putting the machine into service.

**⚠ DANGER**

An operator must not operate the machine, only if:

He has learned and practiced the principles of safe machine operation contained in this operational manual.

- a) Avoid hazardous situations;
- b) Perform a pre-operation inspection at all times;
- c) Implement functional test before operating the machine at all times;

Know and understand functional testing before proceeding to the next step.

- d) Inspect job site;
- e) Only use the machine as it was intended.

### 3.2.2 Open power main switch

Remove the red "Power main switch" to the ON position to turn on the overall power supply.

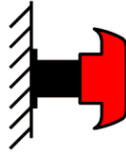

### 3.2.3 Ground function check

- a) Test emergency stop:
  - 1) Select a test area that is firm, level and free of obstruction.
  - 2) Ensure that batteries are connected.
  - 3) Pull out the emergency stop switches of the platform and the ground to the on position;
  - 4) Turn the key switch to ground control.
  - 5) Observe the LED diagnostic reading device on the platform controller, and the LED should be as shown below:



- 6) Observe the LCD diagnostic reading device on the ground controller. The LCD should display operating time, system voltage and battery level. If the indoor and outdoor functions are turned on, OD/ID will be displayed in the upper right corner:

	OD
Working hours (h)	00.00
System Voltage (V)	25.5
Battery power (%)	100

- 7) Push the ground emergency stop switch inward to the off position;
  - 8) Check test result: Any function is not functioning;
  - 9) Pull the ground scram switch out to the on position.
- b) Test the up/down function;
    - 1) This machine uses flashing light and buzzer alarm;
    - 2) Lowering alarm: Light flashes 60 times per minute/Buzzer sounds 60 times per minute;

- 3) Pit protection device not deployed: Light flashes 120 times per minute/Buzzer sounds 120 times per minute;
  - 4) Machine not level: Light flashes 120 times per minute/Buzzer sounds 120 times per minute;
  - 5) Do not hold down the lift enable button;
  - 6) Press and hold the platform up or platform down button;
  - 7) Check test result: The lifting function should not operate;
  - 8) Do not hold the platform up or platform down button;
  - 9) Do not hold down the lift enable button;
  - 10) Check test result: The lifting function should not operate;
  - 11) Press and hold the lift enable button and the platform lift button at the same time;
  - 12) Check test result: Platform shall lift up
  - 13) Press and hold the lift enable button and the platform lowering button at the same time;
  - 14) Check test result: The platform should be lowered. When the platform descends, the descent alarm should flash and sound.
- c) Test emergency lowering.
- 1) Hold down the lift enable button and the platform lift button at the same time to activate the lift function, and lift the platform about 60cm/2ft;
  - 2) Pull out the red emergency drawbar at the bottom of the mast;
  - 3) Check test result: The platform should be lowered. The descent alarm does not sound.

### 3.2.4 Platform function check

- a) Test emergency stop:
- 1) Select a test area that is firm, level and free of obstruction.
  - 2) Turn the key switch to platform control.
  - 3) Push the platform emergency stop switch to the off (off) position;
  - 4) Check test result: None of the features will work.
- b) Test Horn:
- 1) Pull the emergency stop switch to the on position;
  - 2) Press horn button;
  - 3) Check test result: the horn should sound.
- c) Test function enable switch and up/down function;

- 1) Do not press and hold the function enable switch on the control lever;
- 2) Move the control handle slowly in the direction indicated by the blue arrow, then in the direction indicated by the yellow arrow;
- 3) Check test result: None of the functions will work;
- 4) Press the lift function button, the lift function button indicator light up;
- 5) Wait 7 seconds until the lift function button indicator is off, and the lift function times out;



- 6) Move the control handle slowly in the direction indicated by the blue arrow, then in the direction indicated by the yellow arrow;
  - 7) Check test result: The lifting function should not operate;
  - 8) Press the lift function button, the lift function button indicator light up;
  - 9) When the light is on, press and hold the function enable switch on the control lever, and slowly move the control lever in the direction indicated by the blue arrow;
  - 10) Check test result: Platform shall lift up. Pit protection devices should be deployed;
  - 11) Release the control joystick;
  - 12) Check test result: Platform shall stop lifting up.
  - 13) When the light is on, press and hold the function enable switch on the control lever, and slowly move the control lever in the direction indicated by the yellow arrow;
  - 14) Check test result: The platform should be lowered.
- d) Test drive function button;
- 1) Press the drive function button, and the indicator of the drive function button will light up;

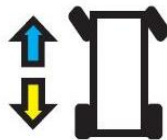

- 2) Wait 7 seconds until the drive function button indicator is off and the drive function times out;
- 3) Move the control handle slowly in the direction indicated by the blue arrow, then in the direction indicated by the yellow arrow;

4) Check test result: None of the features will work.

e) Test the Steering

### **CAUTION**

When performing steering and drive function tests, stand on the steering side of the platform facing the machine.

1) Press the drive function button, and the indicator of the drive function button will light up;

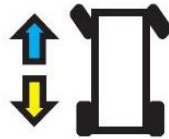

2) Press and hold the function enable switch on the control lever while the light is on;

3) Press and hold the turn thumb button at the top of the control joystick in the direction indicated by the blue triangle on the control panel;

4) Check test result: Steering wheel Should be rotated in the direction indicated by the blue triangle;

5) Press and hold the turn thumb button at the top of the control handle in the direction indicated by the yellow triangle on the control panel;

6) Check test result: Steering wheel It should be turned in the direction indicated by the yellow triangle.

f) Test Drive and Braking:

### **CAUTION**

On any incline the machine can climb, the brakes must be able to stop it.

The test was performed on the ground with a platform controller. Don't stand on the platform.

1) Press the drive function button, and the indicator of the drive function button will light up;

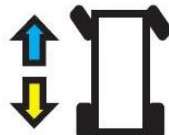

2) Press and hold the function enable switch on the control lever while the light is on;

3) Move the control handle slowly in the direction indicated by the blue arrow on the control panel until the machine begins to move, and then return the control handle to the center position;

- 4) Check test result: The machine should move in the direction indicated by the blue arrow on the control panel and then stop abruptly when the control joystick returns to the center position;
- 5) Move the control handle slowly in the direction indicated by the yellow arrow on the control panel until the machine begins to move, and then return the control joystick to the center position;
- 6) Check test result: The machine should move in the direction indicated by the yellow arrow on the control panel and then stop abruptly when the control joystick returns to the center position;
- g) Test tilt sensor operation;
  - 1) Completely lower the platform;
  - 2) Place a block of  $2 \times 4$ in/ $5 \times 10$ cm or similar size under each of the two wheels on one side of the machine and drive the machine onto the block;
  - 3) Raise the platform approximately 2.3m/ 7ft 7in from the ground.;
  - 4) Check test result: Platform shall stop lifting up. The tilt alarm should sound and the light should flash. Platform console The LED reading device should display LL, and the ground controller LCD should display LL: MachineTilted;
  - 5) Press the drive function button, and the indicator of the drive function button will light up;

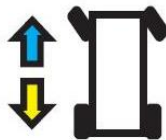

- 6) Press and hold the function enable switch on the control lever;
- 7) Move the control joystick in the direction indicated by the blue arrow, then in the direction indicated by the yellow arrow;
- 8) Check test result: The drive function should not work in either direction;
- 9) Lower the platform and remove two wooden blocks.
- h) Test to increase the driving speed;
  - 1) Raise the platform approximately 2.3m/ 7ft 7in from the ground.;
  - 2) Press the drive function button, and the indicator of the drive function button will light up;

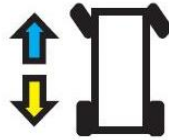

- 3) Press and hold the function enable switch on the control lever. Slowly move the control lever to the full drive position;
- 4) Check test result: The maximum driving speed that can be achieved when the platform is raised should not exceed 22cm/9in per second;
- 5) If the drive speed exceeds 22cm/9in per second while the platform is raised, the machine should be immediately marked and discontinued.

i) Test pothole protection.

### **CAUTION**

When the platform is raised, the pit protection device should be automatically deployed. The pit guard activates the limit switch that allows the machine to continue operating. If the pit protection is not deployed, an alarm will sound and the machine will stop driving or steering.

- 1) Raise the platform;
- 2) Check test result: when the platform is raised 2.3m/7ft 7in from the ground, the pit protection device should be deployed;
- 3) Hold down one side of the pit protection first, then the other side;
- 4) Check test result: Pit protection devices should not move;
- 5) Lower platform;
- 6) Check test result: The pit protection device should be returned to the stowed position;
- 7) Place 2 × 4in/5 × 10cm or similar size wooden blocks under the pit protection;
- 8) Raise the platform;
- 9) Check test result: Before the platform rises about 2.3m/7ft 7in from the ground, the light should flash and the alarm should sound. Platform console LED reading device should display PHS, ground controller LCD should display PHS: Pothole Guard Stuck
- 10) Press the drive function button, and the indicator of the drive function button will light up;

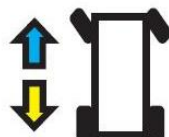

- 11) Press and hold the function enable switch on the control lever;
- 12) Move the control handle slowly in the direction indicated by the blue arrow, then in the direction indicated by the yellow arrow;
- 13) Check test result: The machine should not move forward or backward;
- 14) Press the drive function button, and the indicator of the drive function button will light up;
- 15) Press and hold the function enable switch on the control lever;
- 16) Press and hold the thumb rocker switch at the top of the control joystick in the direction indicated by the blue and yellow triangles on the control panel;
- 17) Check test result: Steering wheel Do not turn left or right;
- 18) Lower platform;
- 19) Remove a  $5 \times 10\text{cm}/2 \times 4\text{in}$  or similar size block.

### 3.2.5 Turning Off the Main Power Switch

If the machine is not used for a long time, press the red "Power main switch" on one side of the battery box to the of (off) position to turn off the power supply.



## 3.3 Workplace Inspection

### **⚠ DANGER**

An operator must not operate the machine, only if:

He has learned and practiced the principles of safe machine operation contained in this operational manual.

- a) Avoid hazardous situations;
- b) Perform a pre-operation inspection at all times;
- c) Implement functional test before operating the machine at all times;
- d) Inspect job site;

Know and understand the pre-operation inspection before going on to the next section.

- e) Only use the machine as it was intended.

### 3.3.1 Basic Principles of workplace inspection

The workplace inspection helps the operator determine if the workplace is suitable for safe machine operation. It should be performed by the operator prior to moving the machine to the workplace.

It is the operator's responsibility to read and remember the workplace hazards, then watch for and avoid them while moving, setting up, and operating the machine.

### 3.3.2 Workplace inspection

Be aware of and avoid the following hazardous situations:

- a) Drop-offs or holes.
- b) Bumps, floor obstructions, or debris.
- c) Sloped surfaces.
- d) Unstable or slippery surfaces.
- e) Overhead obstructions and high voltage conductors.
- f) Hazardous locations.
- g) Inadequate surface support to withstand all load forces imposed by the machine.
- h) Wind and weather conditions.
- i) The presence of unauthorized personnel.
- j) Other possible unsafe situations.

### 3.4 Decal Inspection

Combine the list of data with quantities and descriptions (Table 3-1 to Table 3-8), the label position diagram and the label map (Figure 3-1 to Figure 3-17), and check that the label is easy to identify and appropriate.

**Table 3-1 ZMP04 labels**

No.	Code	Item	Qty
1	00775207050401090	Read instruction carefully label	2
2	00771007010401040	Label - Wheel load 528kg/1164lbs	4
3	00775207050401010	Mind pinch label	2
4	00771007010401060	Label - Collision hazard	2
5	00771007010402010	Label - Right tray	1
6	00771007010402030	Main power switch Label	1
7	00775207050401050	Label -Tie down for lifting	4
8	00771007010401080	Manual force and 230kg/510lbs load label ( Outdoor )	1
9	00775207050402090	Non-insulation mark (English)	1
10	00775207050401040	Forklift hole label	2
11	00775207050402040	Platform AC power label (chassis)	1
12	00775207050403060	Charger Power label	1
13	00775207050401080	Electric shock hazard Label	1
14	00775207050403080	Platform power rated voltage value label	1
15	00771007010402020	Smashing hazard label	1
16	007753070L0401060	Prohibit high pressure water- beaktest	2
17	00771007010401050	Emergency lowering label	1
18	00775207050402050	Handrail position label	2
19	00771007010402040	Label - Left tray	1
20	00771007010402080	Overturning hazard Label	1
21	00775207050401060	Safety lanyard point label	4
22	00771007010402070	Safety rule label (outdoor)	1
23	00771007010402060	Safety rule label I	1
24	00771007010402090	Voltage danger distance label	1

说明书

MACHINE INSPECTION

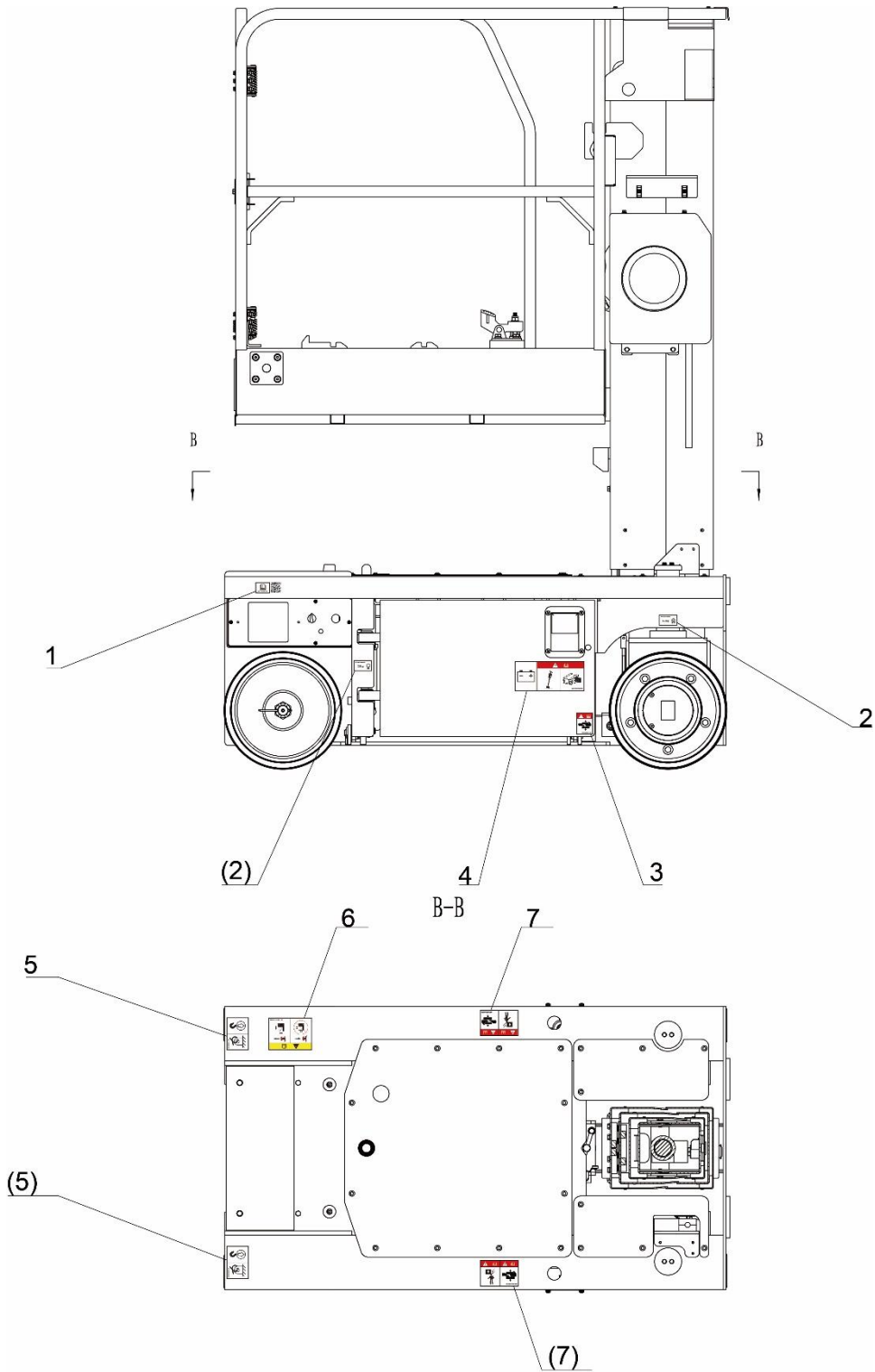

Fig 3-1 ZMP04 Label position 1

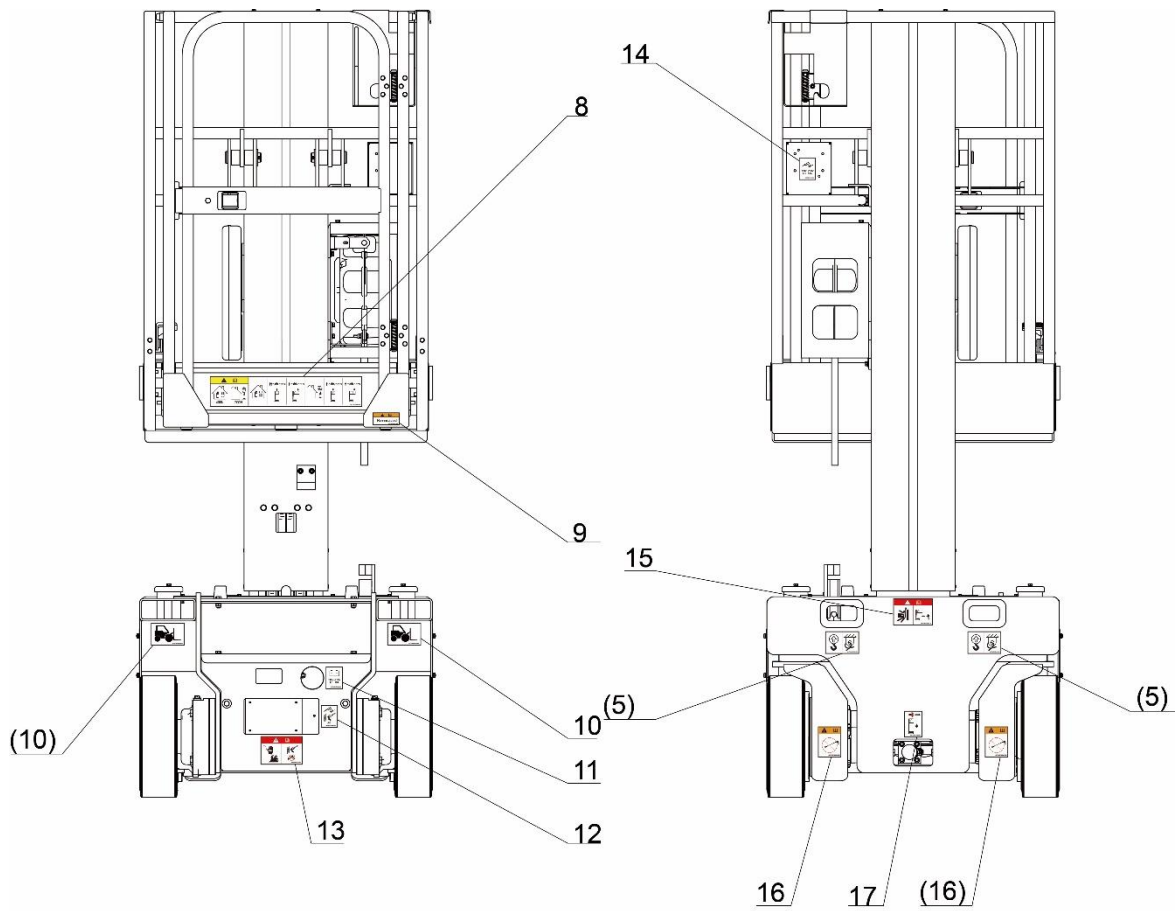

Fig 3-2 ZMP04 Label position 2

起重机械说明

MACHINE INSPECTION

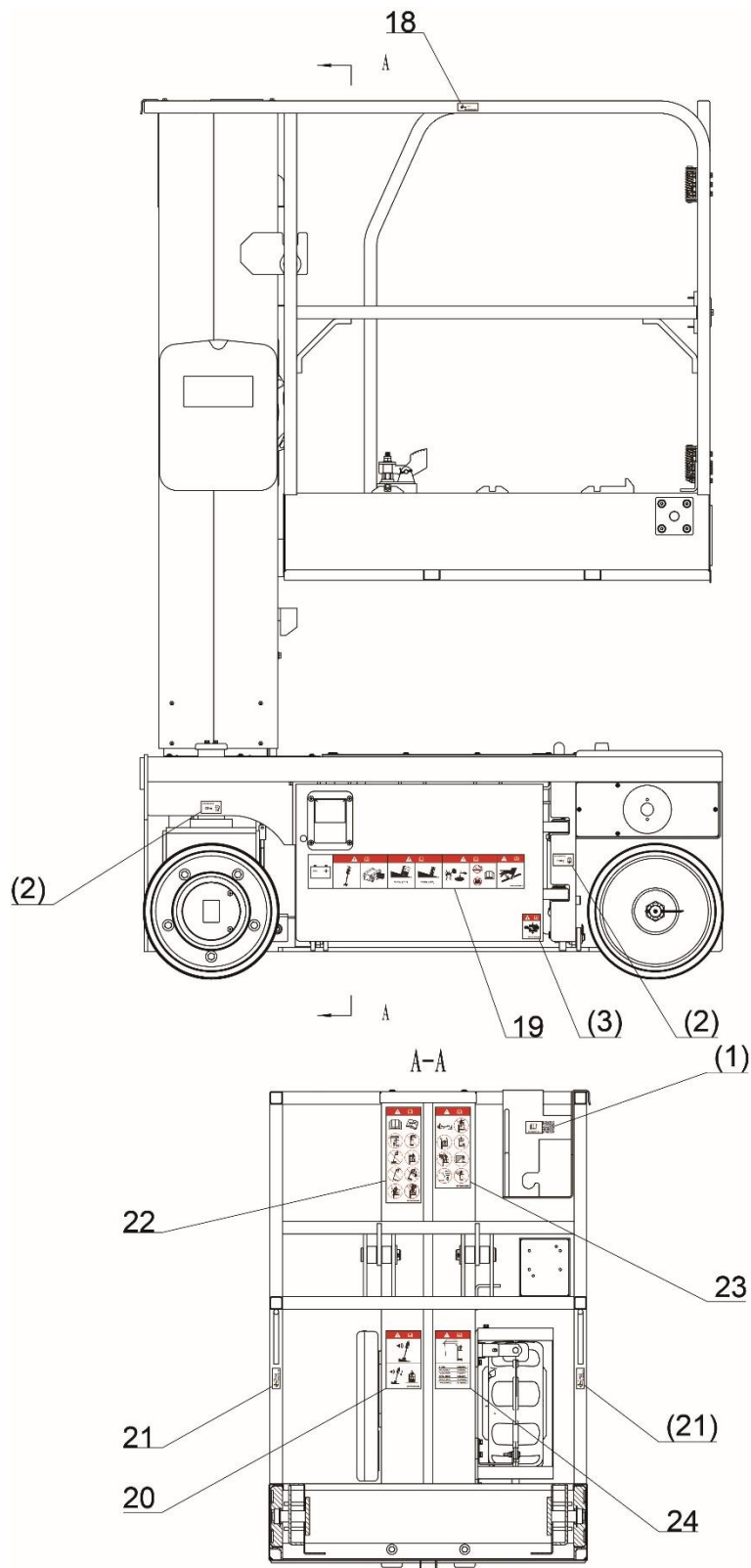
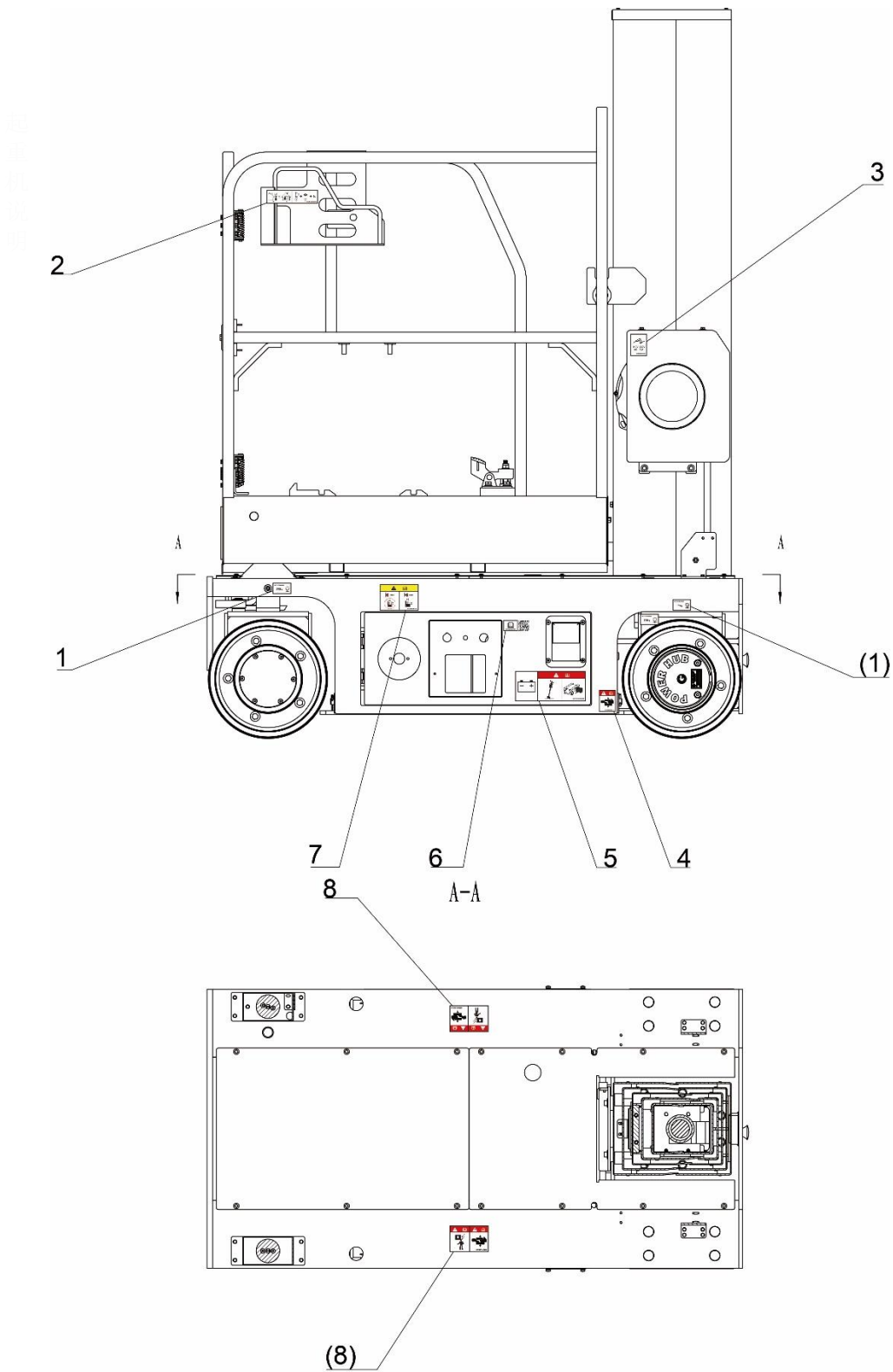

Figure 3-3 ZMP04 Label position 3

**Table 3-2 ZMP05 Label**

No.	Code	Item	Qty
1	00771107020401060	Label - Wheel load 575kg/1268lbs	4
2	00771107020401020	Indoor/outdoor switching label (mast)	1
3	00775207050403080	Platform power rated voltage value label	1
4	00775207050401010	Mind pinch label	2
5	00771007010402040	Label - Left tray	1
6	00775207050401090	Read instruction carefully label	2
7	00771107020401040	Main power switch label (5m/16ft)	1
8	00771007010401060	Label - Collision hazard	2
9	00771107020401050	Manual power and 230kg/510lbs load label (outdoor)	1
10	00775207050402090	Non-insulation mark (English)	1
11	00775207050401050	Label -Tie down for lifting	4
12	00771007010402020	Smashing hazard label	1
13	00775207050401040	Forklift hole label	2
14	007753070L0401060	Prohibit high pressure water- beaktest	2
15	00771007010401050	Emergency lowering label	1
16	00775207050402050	Handrail position label	2
17	00771107020401030	Right tray label (5m/16ft)	1
18	00775207050402040	Platform AC power label (chassis)	1
19	00775207050403060	Charger Power label	1
20	00775207050401060	Safety lanyard point label	4
21	00771007010402080	Overturning hazard Label	1
22	00771007010402060	Safety rule label I	1
23	00771207010401060	Safety rule label (indoor)	1
24	00771007010402090	Voltage danger distance label	1



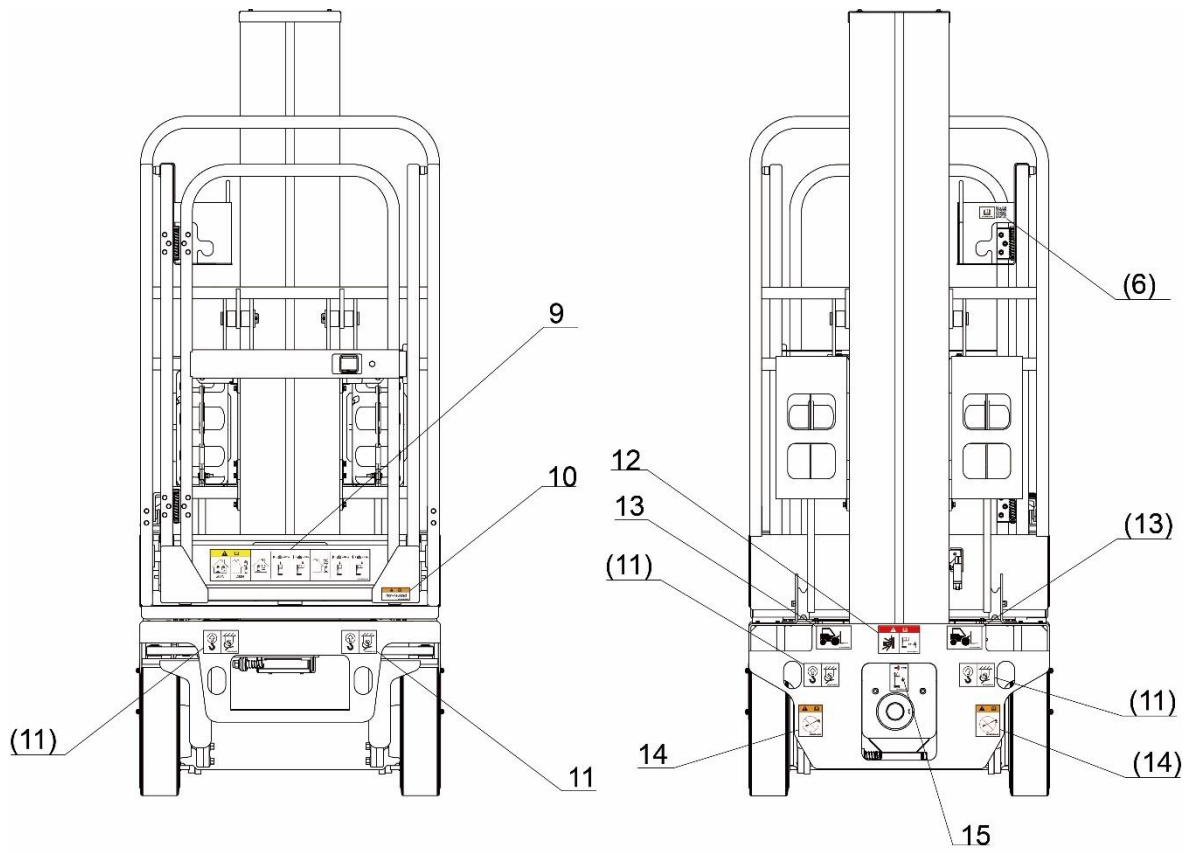

Figure 3-5 ZMP05 label position 2

起吊机说明书

MACHINE INSPECTION

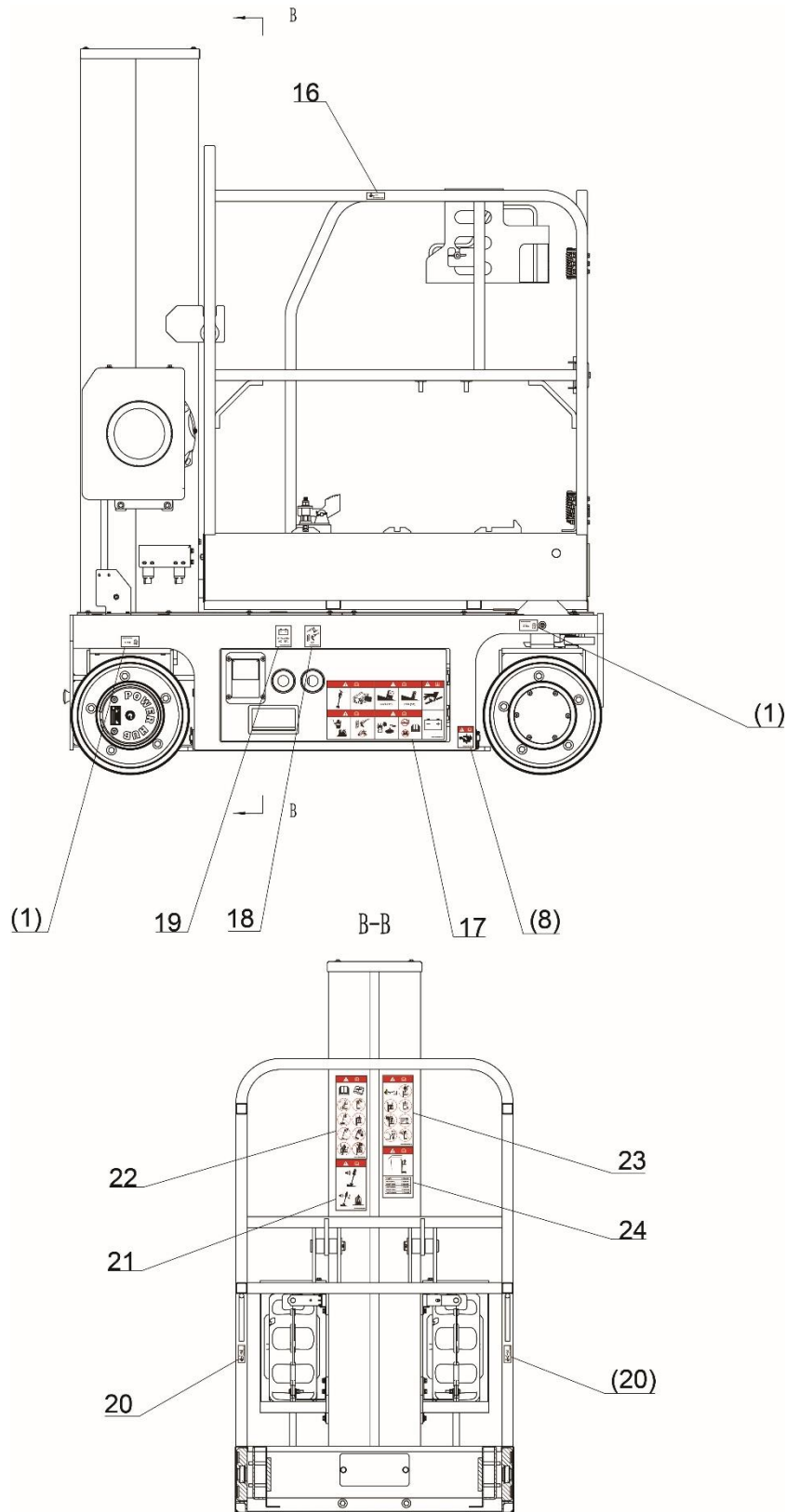

Figure 3-6 ZMP05 label position 3

**Table 3-3 ZMP06 Label**

No.	Code	Item	Qty
1	00775207050401090	Read instruction carefully label	2
2	00771207010401030	Label - Wheel load 660kg/1455lbs	4
3	00775207050401010	Mind pinch label	2
4	00771007010401060	Label - Collision hazard	2
5	00771007010402010	Label - Right tray	1
6	00771007010402030	Main power switch Label	1
7	00775207050401050	Label -Tie down for lifting	4
8	00771207010401040	Manual force and 200kg/440lbs load label ( indoor )	1
9	00775207050402090	Non-insulation mark (English)	1
10	00775207050401040	Forklift hole label	2
11	00775207050402040	Platform AC power label (chassis)	1
12	00775207050403060	Charger Power label	1
13	00775207050401080	Electric shock hazard Label	1
14	00775207050403080	Platform power rated voltage value label	1
15	00771007010402020	Smashing hazard label	1
16	007753070L0401060	Prohibit high pressure water- beaktest	2
17	00771007010401050	Emergency lowering label	1
18	00775207050402050	Handrail position label	2
19	00771007010402040	Label - Left tray	1
20	00775207050401060	Safety lanyard point label	4
21	00771007010402080	Overturning hazard Label	1
22	00771207010401060	Safety rule label (indoor)	1
23	00771007010402060	Safety rule label I	1
24	00771007010402090	Voltage danger distance label	1

起吊机说明书

MACHINE INSPECTION

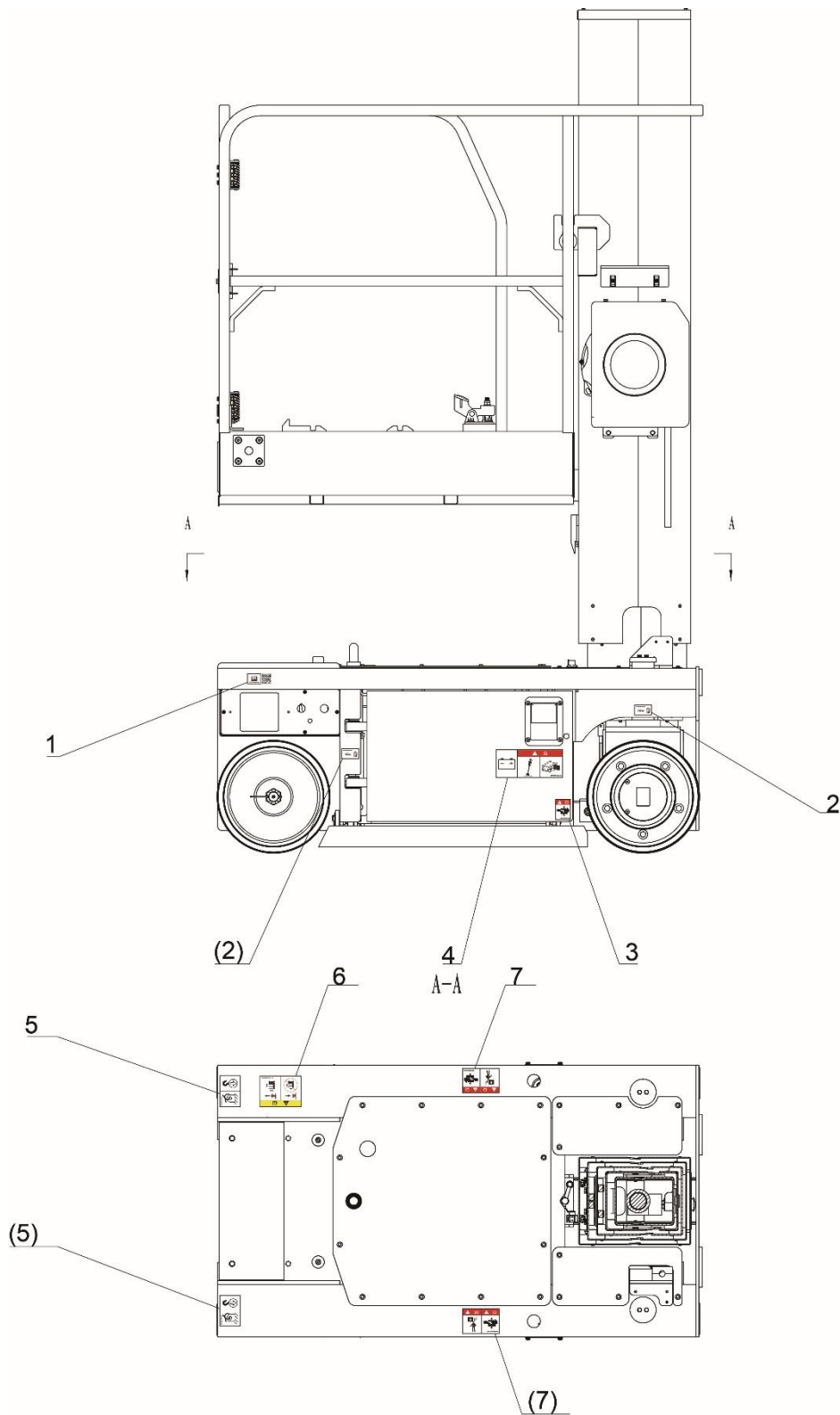

Figure 3-7 ZMP06 label position 1

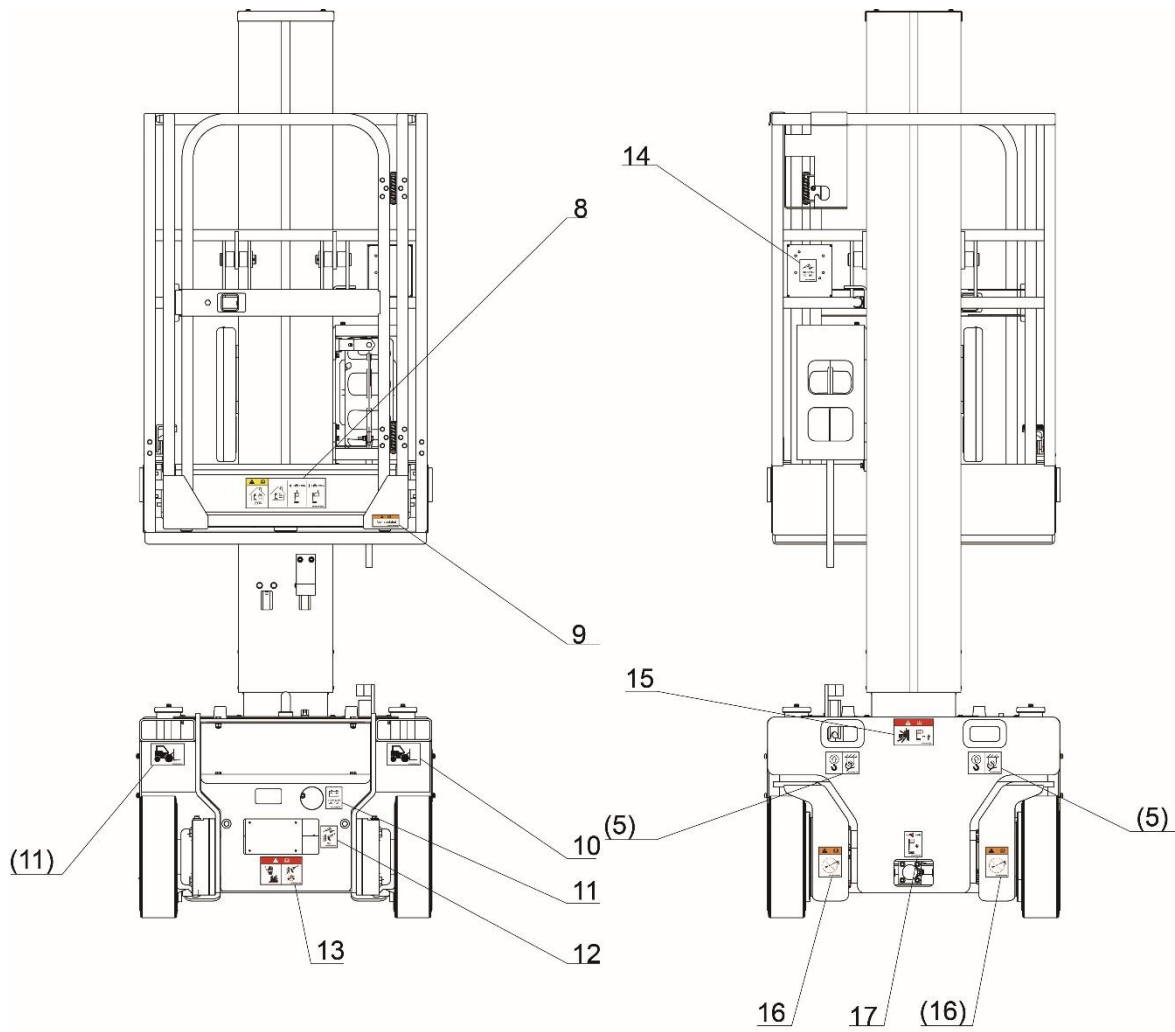

Figure 3-8 ZMP06 label position 2

起重机说明

MACHINE INSPECTION

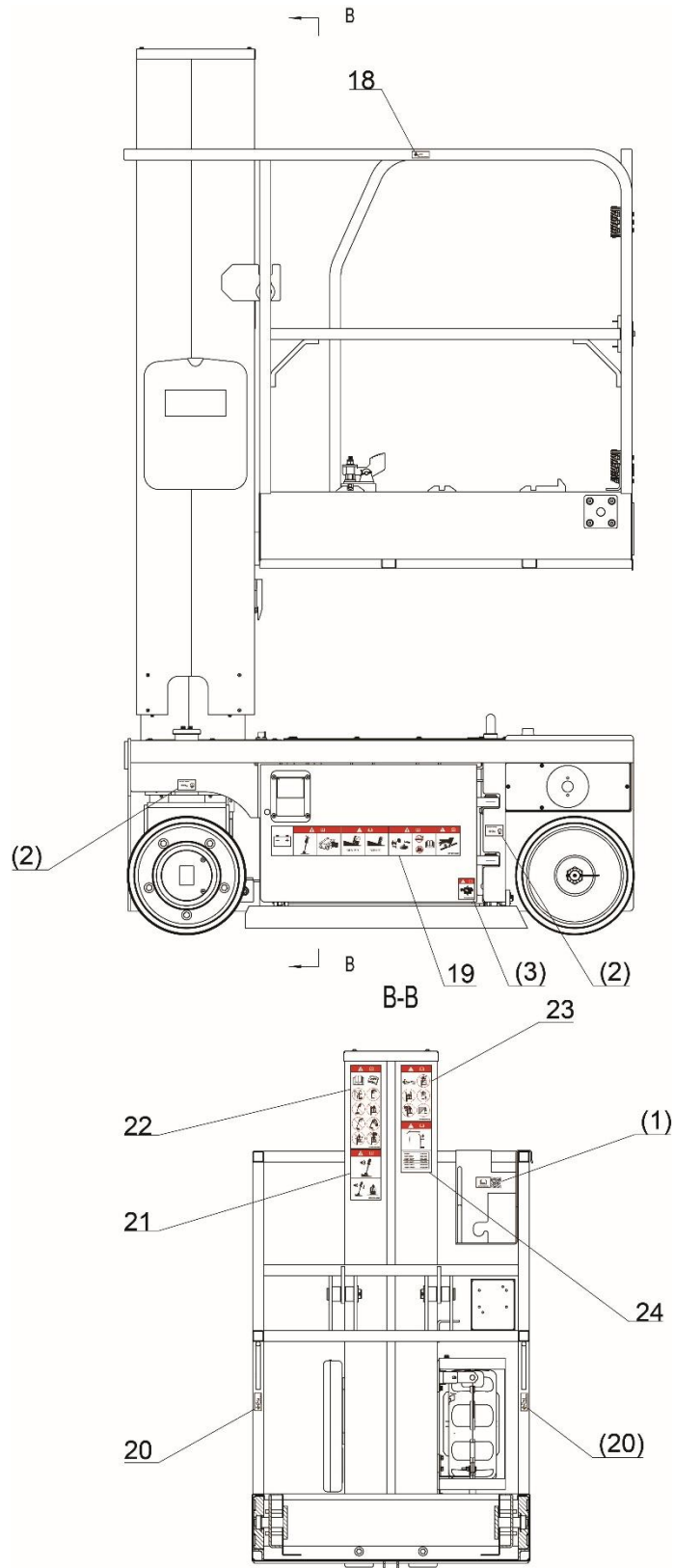

Figure 3-9 ZMP06 label position 3



Figure 3-10 ZMP04 label assembly

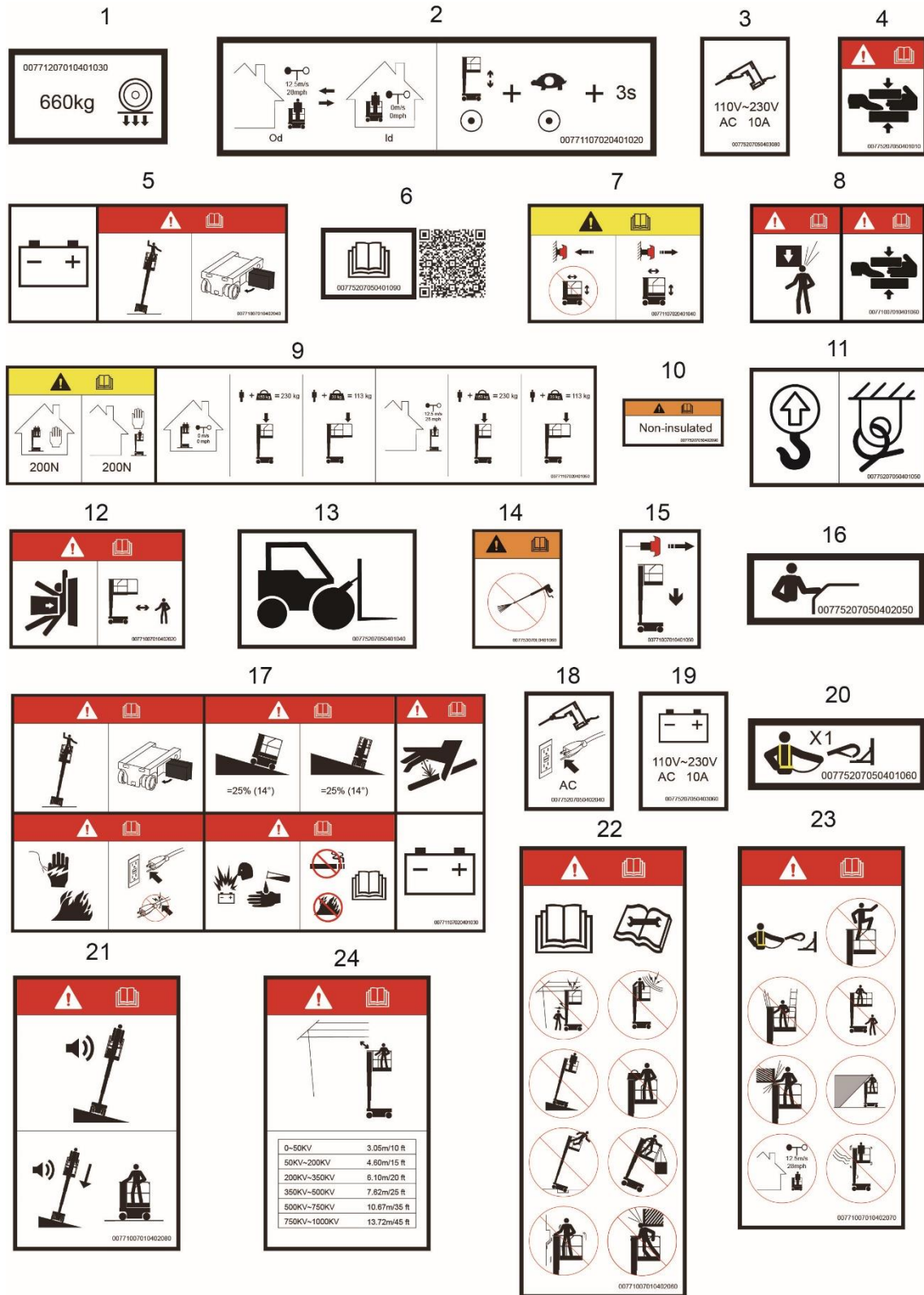

Figure 3-11 ZMP05 label assembly

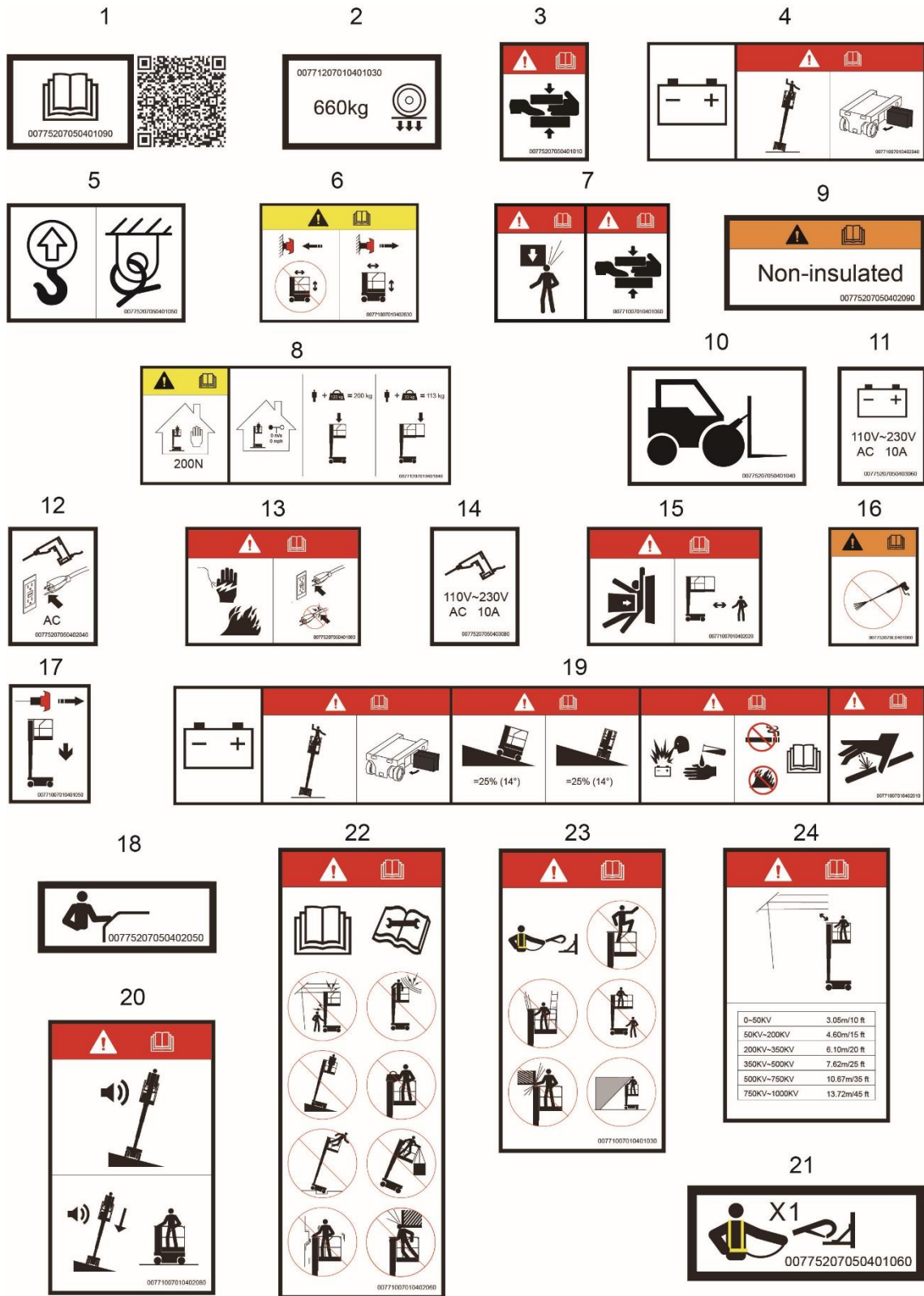
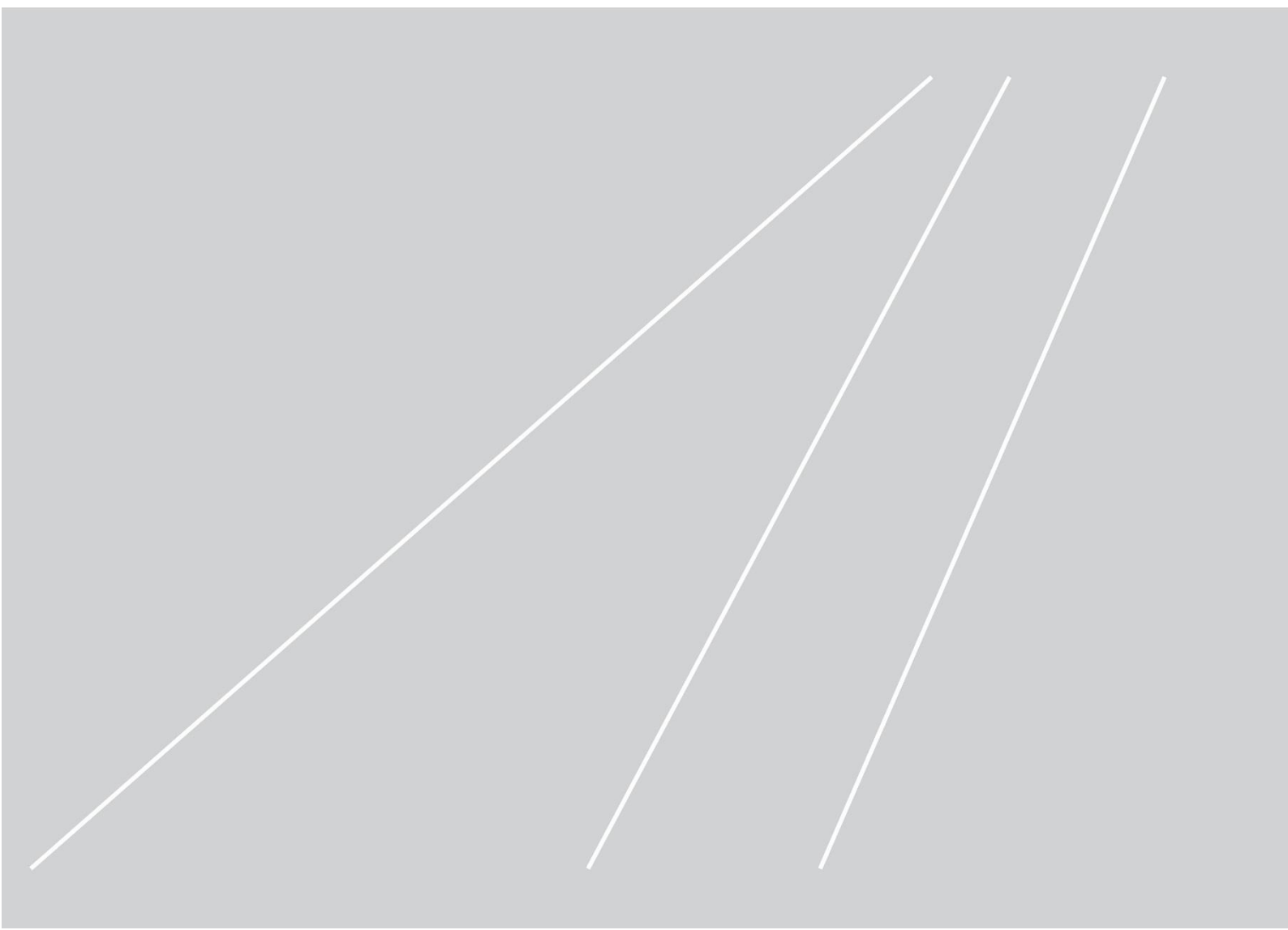

Figure 3-12 ZMP06 label assembly

# ZOOMLION

Operation and Safety Manual

Section 4 Operation Instruction





## SECTION 4 OPERATION INSTRUCTION

### 4.1 General

#### **⚠ DANGER**

An operator must not operate the machine, only if:

He has learned and practiced the principles of safe machine operation contained in this operational manual.

- a) Avoid hazardous situations;
- b) Perform a pre-operation inspection at all times;
- c) Implement functional test before operating the machine at all times;
- d) Inspect job site;
- e) Only use the machine as it was intended.

Fundamentals:

The Operating Instructions section provides instructions for each aspect of machine operation. It is the operator's responsibility to follow all the safety rules and instructions in the operator's, safety and responsibilities manuals.

Using the machine for anything other than lifting personnel, along with their tools and materials, to an aerial work site is unsafe and dangerous.

Trained and authorized personnel operate the machine only. Only trained and authorized personnel should be permitted to operate a machine. If more than one operator is expected to use a machine at different times in the same work shift, they must all be qualified operators and are all expected to follow all safety rules and instructions in the operator's, safety and responsibilities manuals. That means every new operator should perform a pre-operation inspection, function tests, and a workplace inspection before using the machine.

### 4.2 Basic Operation

#### 4.2.1 Open or close power main switch

- a) Push the red "power main switch" on one side of the chassis to the off (off) position to disconnect the overall power supply;
- b) Before vehicle operation, pull out the red "power main switch" to the on (ON) position.

In case of prolonged shutdown or maintenance inspection, the "power main switch" should be turned off.



#### 4.2.2 Emergency stop

- a) Push the emergency stop switch on the ground controller or platform controller to the off position to stop all functions;
- b) Repair of any operating function must be performed when the red "power main switch button" and emergency stop switch are pressed.

#### 4.2.3 Emergency lowering

Pull the emergency lowering pull rod to lower the platform.

#### 4.2.4 Post-use operation

- a) Choose a safe parking location, which can be solid level ground, free of obstacles, and away from heavy traffic;
- b) Lower platform;
- c) Turn the key switch to the off (off) position and remove the key to avoid unauthorized use;
- d) Charge the battery.

### 4.3 Ground console operation

#### **▲ CAUTION**

Maintain a safe distance between operator, machine and fixed objects.

When using the controller, pay attention to the direction of travel of the machine.

#### 4.3.1 Activate ground console

- a) Ensure that the battery is connected before operating the machine;
- b) Turn the key switch to ground control.
- c) Pull the ground and platform emergency stop switches to the on (ON) position.

#### 4.3.2 Adjust platform position

To adjust the position of the platform, hold down the lift enable button and the platform lift or drop button at the same time in the control panel.

Drive and steering functions are not available through ground controllers.

## 4.4 Platform operation

### 4.4.1 Activate platform console

- a) Ensure that the battery is connected before operating the machine;
- b) Turn the key switch to platform control.
- c) Pull the ground and platform emergency stop switches to the on (ON) position.

### 4.4.2 Adjust platform position

- a) Press the lifting function button;

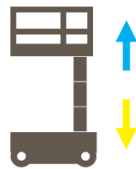

A ring light will light up below the lift function symbol.

If the joystick is not moved within 7 seconds of pressing the lift function button, the ring indicator under the lift function symbol will go off and the lift function will not operate.

- b) Press and hold the function enable switch on the control lever while the lift function indicator is on.
- c) Move the joystick according to the mark on the control panel.

### 4.4.3 Steering

- a) Press the Drive function button;

A ring light will light up below the drive function symbol.

If the joystick is not moved within 7 seconds of pressing the drive function button, the ring indicator under the drive function symbol will go off and the lift function will not operate.

- b) Press and hold the function enable switch on the control lever while the drive function indicator is on.
- c) According to the mark on the control panel, press and hold the turn thumb button on the top of the control joystick to make the turn.



#### 4.4.4 Driving

- a) Press the Drive function button; A ring light will light up below the drive function symbol.

If the joystick is not moved within 7 seconds of pressing the drive function button, the ring indicator under the drive function symbol will go off and the lift function will not operate.

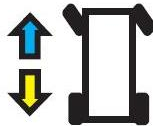

- b) Press and hold the function enable switch on the control lever while the drive function indicator is on.
- c) Increasing speed: Slowly move the control joystick off center.
- d) Decreasing speed: Slowly move the control joystick toward the center position;
- e) Stop: Return the control joystick to the center position or release the function enable switch;
- f) Use the platform controller and the color code direction arrow on the platform to determine the direction of the machine;
- g) When the platform is raised above the safe height, the machine movement speed will be limited;
- h) The battery condition will affect the performance of the machine. When the battery level indicator blinks, the machine drive speed and function speed will decrease.

#### 4.4.5 Drive speed selection

Normally, the drive controller is in the normal speed mode, and the maximum drive speed can be achieved by adjusting the control joystick. When the slow mode button is pressed, a ring indicator light will light up below the center of the button, and the drive slow mode will start, even if the joystick travel to the maximum, the drive speed will be limited.



#### 4.4.6 Platform AC power (AC 220V)

When using platform AC power (if the machine is equipped), pull out the three-hole power plug from the left side of the chassis climb staircase at the rear of the machine or from the side of the chassis and connect it to the grounded AC three-wire power supply (AC 220V) outlet. The AC power socket on the platform can provide 220V AC power.

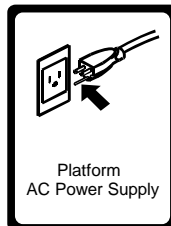

### 4.4.7 Indoor and outdoor working mode selection

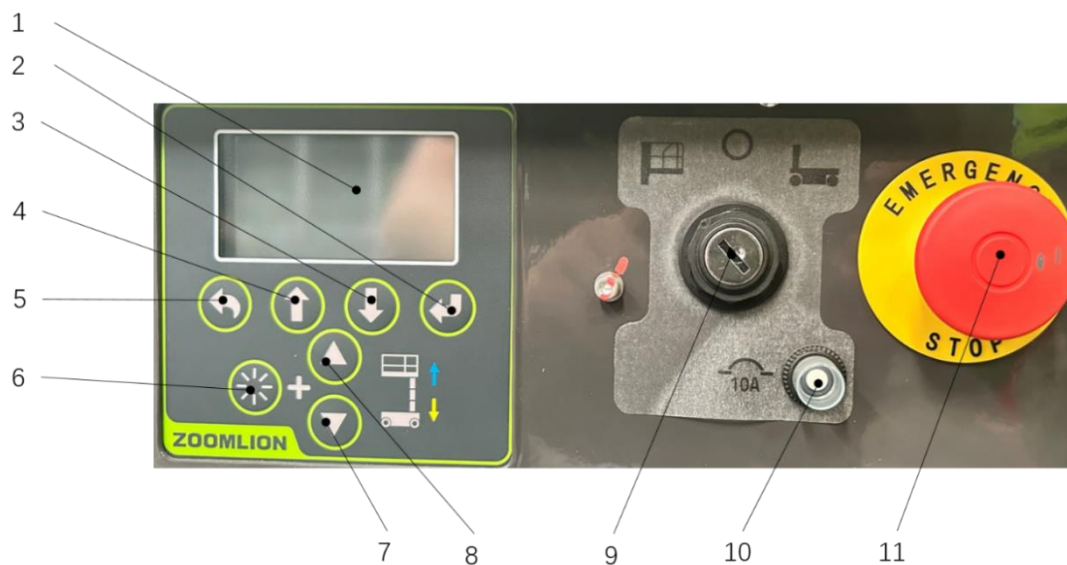

Figure 4-1 ZMP04/ZMP06 Ground control console

Table 4-1 ZMP04/ZMP06 Ground control console instruction

No.	Item	No.	Item
1	LCD diagnosis reading device	7	Platform lowering button
2	Menu enter button	8	Platform up button
3	Menu down button	9	Key switch
4	Menu up button	10	10A breaker
5	Menu exit button	11	Emergency stop switch
6	Lifting enable button		



Figure 4-2 ZMP05 Ground control console

Table 4-2 ZMP05 Ground control console instruction

No.	Item	No.	Item
1	Key switch	7	LCD diagnosis reading device
2	10A breaker	8	Menu down button
3	Menu exit button	9	Menu enter button
4	Menu up button	10	Platform up button
5	Lifting enable button	11	Platform lowering button
6	Emergency stop switch		



**Figure 4-3 ZMP04/ZMP05/ZMP06 Platform control panel**

**Table 4-3 ZMP04/ZMP05/ZMP06 Platform control panel instruction**

No.	Item	No.	Item
1	Emergency stop switch	5	Steering thumb button
2	Horn button	6	LED indicator
3	Lifting function button	7	Drive function button
4	Joystick	8	Drive speed button

a) Push the emergency stop switch to OFF position, and turn the key switch to Ground position. Press the Input button on menu and pull out emergency stop button to ON position to enter the Menu interface.

b) Press Down button, then press Enter button when the display shows as below.

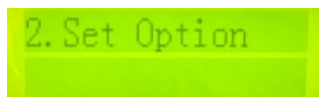

c) Continuously press Down button until the below interface shows up, then press the Enter button.



d) If off is selected, indicating indoor and outdoor functions disabled, only indoor working mode is allowed at this time, as shown in(h).

If on is selected, indicating indoor and outdoor functions enabled, then press Enter button, at this time, the default is outdoor working mode, as shown in(g).

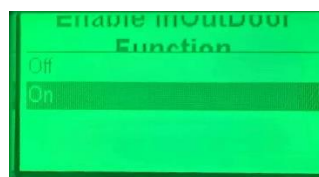

e) Restart the machine, turn the key switch to Platform position, operate the machine through the platform control panel.

f) If the below two interfaces automatically switch back and forth, the machine is in outdoor working mode at this time.

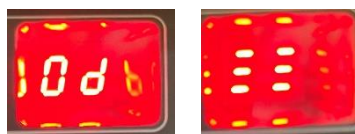

g) Press Lifting function button and Driving speed button at the same time, when the below two interfaces switch back and forth, release the buttons, at this time, the machine is in indoor working mode.

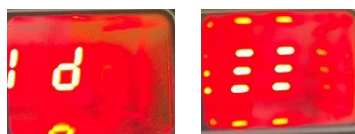

## 4.5 Slope Operation

### 4.5.1 Drive on slopes

**⚠ DANGER**

- a) Determine the longitudinal and lateral rating and slope of the slope in the stowed state;

**Table 4-4 Vertical ratings**

The maximum vertical rating in the stowed state			
	ZMP04/ZMP05/ZMP06	25%	14 °

**Table 4-5 Lateral ratings**

Maximum lateral rating of the stowed state			
	ZMP04/ZMP05/ZMP06	25%	14 °

- b) Slope ratings are limited by ground conditions and traction, press the drive speed button to select the fast drive speed mode.
- c) Measure the slope with a digital inclinometer or follow these steps to measure the slope.

The required tools: Carpenter's ruler, straight wood block (length of at least 1m/3ft 3in), tape measure.

- 1) Place the block on the slope;
- 2) At the end of the downhill slope, place the carpenter's ruler on the upper edge of the block and raise the end of the block until it is level;
- 3) Keeping the block level, measure the vertical distance from the base of the block to the ground. Divide the distance of the tape measure (rise) by the length of the block (run), then multiply by 100.

Example:

Block=3.6m/12ft (144in);

Stroke=3.6m/12ft (144in);

Lifting height=0.3m/12in;

$$0.3m/12in \div 3.6m/144in = 0.083 \times 100 = 8.3\%$$



If the slope exceeds the maximum uphill, downhill or side rating, the machine must be lifted or transported up and down the slope. See "Transportation and Lifting" section.

### 4.5.2 Work on slope

**⚠ DANGER**

Determine the rating of the chassis operating angle when the machine is operating longitudinally and laterally on slopes.

**Table 4-6 Max chassis slope**

Model	Vertical ratings	Lateral ratings
ZMP04/ZMP05/ZMP06	3 °	1.5 °

If the slope exceeds the chassis operating angle rating and the tilt alarm sounds, the platform must be lowered carefully. Move the machine to a solid level ground before lifting.

### 4.6 Traction

- a) Note that electric drive DC/AC models:

It is not recommended that pull this equipment except in the event of an emergency of equipment failure or complete loss of equipment power.

- b) Warning:
  - 1) If the machine has any tilt, the wheels must be fully blocked before manually releasing the brakes, otherwise injury or even death may result;
  - 2) Risk of vehicle/equipment loss of control. The device does not have traction brakes and the traction vehicle must be able to control the device at all times. No towing on the highway. Failure to follow these instructions may result in serious injury or death.
  - 3) The maximum towing speed is 3.2 km/h (2mile/h) and the towing distance does not exceed 18 m (60 ft). The maximum traction grade is 25%.
- c) The device provides four ways to release the brake, which are electronic control release brake, click-to-release brake and mechanical release brake. The electronic control release is divided into two ways:
  - 1) Electronic brake release mode 1 (DC/AC models):
    - ① Remove the main power switch, platform control emergency stop button, ground control emergency stop button;
    - ② Press and hold the "Menu entry button" on the ground controller without releasing it;

OPERATION INSTRUCTION

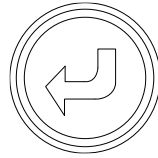

- ③ Turn the key switch to the ground control;
- ④ Until the LCD reading device appears the following interface:

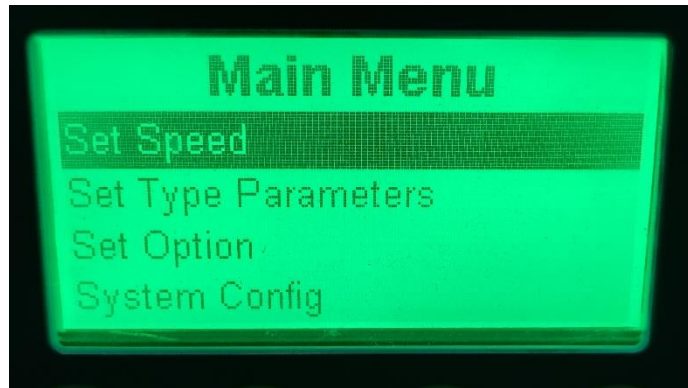

- ⑤ Press the "Menu Down button", turn the page to the following interface, and select "Other" :

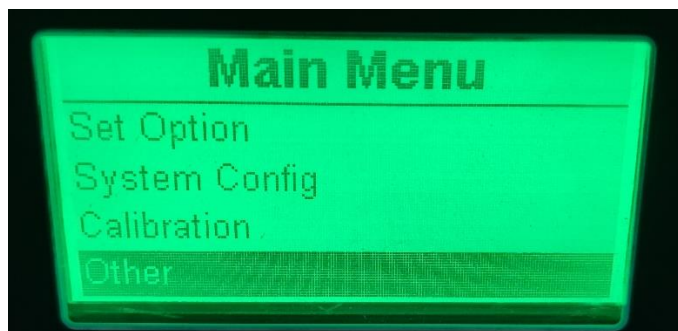

- ⑥ Select "Release brake" by pressing the "Menu Down button" :



- ⑦ Long press the "menu enter button", the following interface is displayed, and the buzzer alarm indicates that the brake has been released;



⑧ The equipment traction is completed, turn off the key switch, and the brake is restored.

2) Electronic brake release mode 2 (DC/AC models):

- ① Remove the main power switch, platform control emergency stop button, ground control emergency stop button;
- ② Turn the key switch to the ground control;
- ③ Simultaneously press and hold the lift and drop buttons on the ground controller for 5s;



④ Until the LCD reading device shows the following interface, while the buzzer alarm, indicating that the brake has been released:

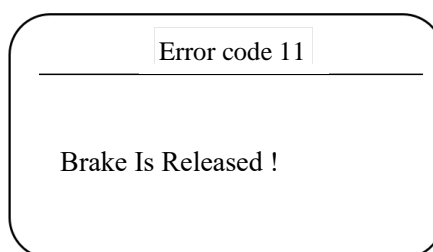

⑤ The equipment traction is completed, turn off the key switch, and the brake is restored.

3) Click to release brake (models equipped with brake release button) :

- ① Remove the main power switch, platform control emergency stop button, ground control emergency stop button;
- ② Turn the key switch to the ground control, press and hold the brake release button for 3 seconds within 20 seconds, and the buzzer alarms, indicating that the brake has been

released. See the below diagram;

- ③ The equipment traction is completed, turn off the key switch, and the brake is restored.

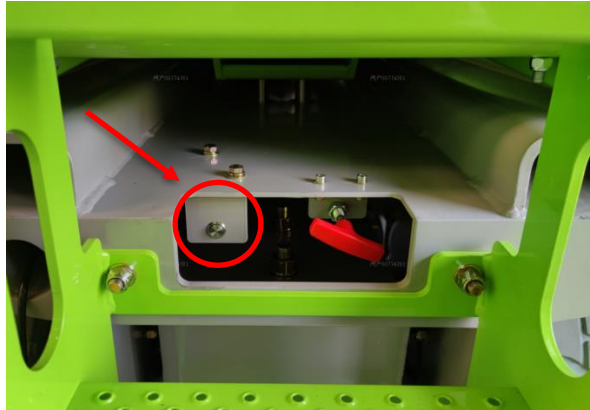

**Figure 4-4 Brake release button position indication**

#### 4) Mechanical Release brake (DC models):

- ① Press the main power switch, platform control emergency stop button, ground control emergency stop button;
- ② Remove the two rear cover bolts. The brake cover bolts are also the release bolts of the brake. The size of the rear cover bolt is M5×0.8×20mm, as shown in the figure below.
- ③ Remove the brake cover, see the number 2 below;
- ④ Insert the rear cover bolt 1 into the two manual release holes 3 of the brake housing;

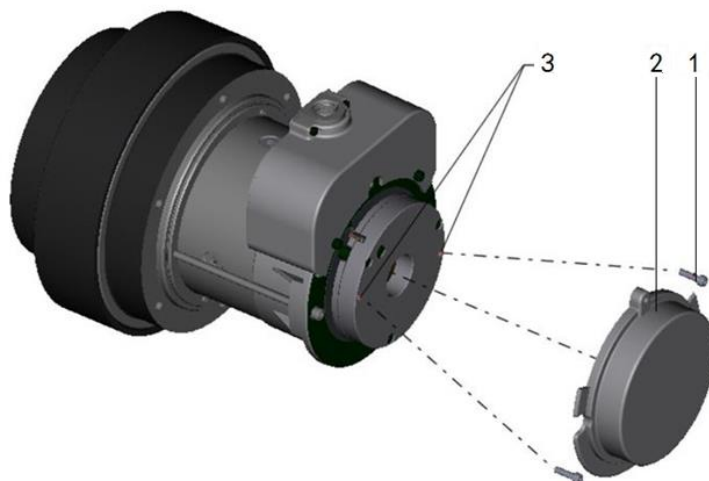

**Figure 4-5 Brake diagram**

- ⑤ Tighten the bolt and the brake will be released;
- ⑥ Repeat the process for the other wheel drive.

After the machine is towed or pushed to the maintenance position, the brake must be restored.

## 4.7 Operation Code

### 4.7.1 Operation Indicator Code

If the platform controller LED or ground controller LCD diagnostic reading device displays an operation indicator code such as LL, the fault condition must be repaired or removed before machine operation can continue. Press in and pull the red emergency Stop button to reset the system.

- a) LED reading device



- b) LCD reading device



- c) Operation indicator code meaning:
- 1) LL machine tilt fault;
  - 2) OL platform overload;
  - 3) CH chassis mode operation;
  - 4) 18 Pothole Guard Stuck;
  - 5) 37 Battery runs out and power off.

For more information, refer to the corresponding ZOOMLION Maintenance Manual.

View the code and code description on the LCD of the ground controller.

### 4.7.2 Platform overload

If the platform controller LED diagnostic reading device displays flashing OL, and the ground controller LCD diagnostic reading device also displays OL: The Platform Overloaded indicates that the current platform is overloaded and all functions stop, except the descending function. The alarm will go off.





- a) Press the emergency stop switch into the off (off) position;

- b) Remove the load from the platform;
- c) Pull the emergency stop switch to the on position;
- d) The reading device displays normally.

**4.7.3 Battery capacity indicator**

Use an LED diagnostic reading device to determine battery or lithium battery levels.

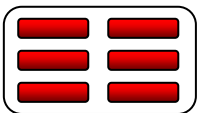
Platform console When there is only one grid of power on the LED display, the machine must be stopped and charged, otherwise all machine functions will be disabled.

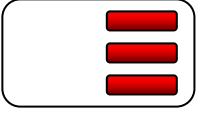
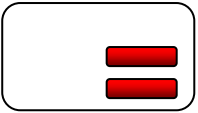
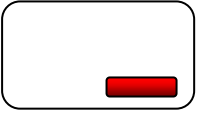
	
Capacity: 90 - 100%	Capacity: 70%
	
Capacity: 50%	Capacity: 30%
	
Capacity: 20%	Capacity: 10%

**4.8 Battery and Charger Operation**

**⚠ CAUTION**

Battery and charger instruction

**4.8.1 Matters to be observed**

- a) Do not use external chargers or booster batteries;
- b) Charge the battery in a well-ventilated area;
- c) Charge using the correct AC input voltage indicated on the charger;
- d) Use only batteries and chargers approved by ZOOMLION.

**4.8.2 Charge the battery**

- a) Make sure the battery is connected before charging.

- b) Keep the battery tray closed and out of the rain while the battery is charging.

#### 4.8.3 Maintenance free battery

- a) Connect the battery charger to a grounded AC circuit;
- b) The charger will indicate when the battery is full.

#### 4.8.4 Standard Battery

- a) Remove the battery ventilation cover and check the battery acid level. If necessary, only add enough distilled water to cover the plate. Do not add excess before the charging process;
- b) Cover the battery ventilation cover;
- c) Connect the battery charger to a grounded AC circuit;
- d) The charger will indicate when the battery is full.
- e) Check the acid level of the battery at the end of the charging cycle. Fill the bottom of the feeder with distilled water. Do not add too much.

#### 4.8.5 Dry Battery filling and charging instructions

- a) Remove the battery vent cover and permanently remove the plastic seal from the battery vent;
- b) The battery acid (electrolyte) is filled to each unit until the level can cover the plate;
- c) Do not fill the battery to the highest level before the end of the charging process. Overloading may cause the battery acid to overflow during charging. Use sodium bicarbonate and water to neutralize spilled battery acid.
- d) Cover the battery ventilation cover;
- e) Charge the battery;
- f) Check the acid level of the battery at the end of the charging cycle. Fill the bottom of the feeder with distilled water. Do not add too much.

### 4.9 Li-ion battery and Charger Operation

#### **▲ CAUTION**

Li-battery and charger instruction

#### 4.9.1 Matters to be observed

- a) The power of the lithium battery fast charger is 1500W, and the charging AC input current is 8A. Please choose a power socket with sufficient load to charge the device. The conventional ordinary socket (10A) can only charge one device.

- b) Do not overcharge or overdischarge the battery system.
- c) During the use of the battery, if there is heat, deformation, leakage, odor or smoke, you must immediately stop using the battery, and put the battery in an open place away from people;
- d) The battery is only applicable to the supporting equipment, do not use the battery in other occasions;
- e) Do not use wire to directly short circuit the battery output;
- f) Do not use or store this product in corrosive, explosive, high temperature (heating, near fire or sun exposure, etc.) environment;
- g) When charging, please use the special charger that comes with the device, and avoid charging in direct sunlight. Do not let children touch the charger while charging.
- h) If the battery system is not used for a long time, it should be placed in a cool and dry environment (temperature below 30 degrees, humidity less than 90%), and charged at least once every three months;
- i) When the battery voltage is too low, it should be charged in time, otherwise the battery will overdischarge protection and cause the vehicle to not move;
- j) Do not apply external force to the battery or make it fall from a high altitude;
- k) The battery should not be near the high temperature heat source;
- l) Do not use an external charger or booster battery to charge the battery;
- m) Charge the battery in a well-ventilated area;
- n) Charge using the correct AC input voltage indicated on the charger;
- o) Use only chargers approved by ZOOMLION.
- p) It is strictly prohibited for non-professionals to disassemble and modify the battery system. If you need maintenance, please contact our after-sales personnel.

#### 4.9.2 Charge the li-battery

- a) Connect the li-battery charger to a grounded AC circuit;
- b) Keep the battery tray closed and out of the rain while the battery is charging.
- c) The charger will indicate when the battery is full.

### 4.10 Transport and Lifting

#### 4.10.1 Matters to be observed

- a) ZOOMLION provides this securement information as a recommendation. Drivers are solely responsible for making sure machines are properly secured and the correct trailer is selected

pursuant to CHINA Department of Transportation regulations, other localized regulations, and their company policy.

- b) ZOOMLION customers needing to containerize any lift or ZOOMLION product should source a qualified freight forwarder with expertise in preparing, loading and securing construction and lifting equipment for international shipment.
- c) Only qualified aerial lift operators should move the machine on or off the truck.
- d) The transport vehicle must be parked on a level surface.
- e) The transport vehicle must be secured to prevent rolling while the machine is being loaded.
- f) f) Be sure the vehicle capacity, loading surfaces and chains or straps are sufficient to withstand the machine weight. ZOOMLION lifting equipment is heavy for its size. See the serial label for the maximum rated load.
- g) Be sure the machine is on a level surface or secured before releasing the brake.
- h) Prevent the guardrail from falling when removing the latch. Always grasp the guardrail when lowering it;
- i) Do not drive the machine on a slope that exceeds the maximum uphill, downhill or side slope rating of the machine. See "Driving on Slopes" in the "Operating Instructions" section;
- j) If the slope of the transport vehicle bed exceeds the maximum slope rating, the machine must be loaded and unloaded using a winch as described in the brake release operation.

#### 4.10.2 Transportation Operations

- a) Brake release operation:

- 1) Chock the wheels to prevent the machine from rolling.



- 2) Be sure the winch line is properly secured to the drive chassis tie points and the path is clear of all obstructions.
- 3) Push the black brake release knob to open the brake valve (HD/HA series);



- 4) Push and pull red brake release pump knob (HD/HA series);
- 5) DC/AC series vehicle brake release for other details, see 4.6.
- b) If the machine overload:
  - 1) Chock the wheels to prevent the machine from rolling.

- 2) Pull the red "Emergency Stop" button on both ground and platform controllers to the on (on) position (HD/HA series);
  - 3) Press and hold the drive/steering function enable switch on the joystick. Remove the joystick from the center and release it immediately to reset the brake (HD/HA series);
  - 4) Push the red "Emergency Stop" button at both ground and platform controllers to the off position.
- c) No traction is recommended. If the machine must be pulled, the speed should not exceed 3.2 km/h;
- d) Pay attention to the transporting safety.
- 1) Expansion platform locks should usually be used when transporting machines. Before transportation, turn the key switch to the off (off) position, and then remove the key;
  - 2) Inspect the entire machine for loose or unsecured items. Make sure the chain or belt has sufficient load strength.

Use a minimum of 2 chains or belts. Adjust rigging to prevent damage to the chain.

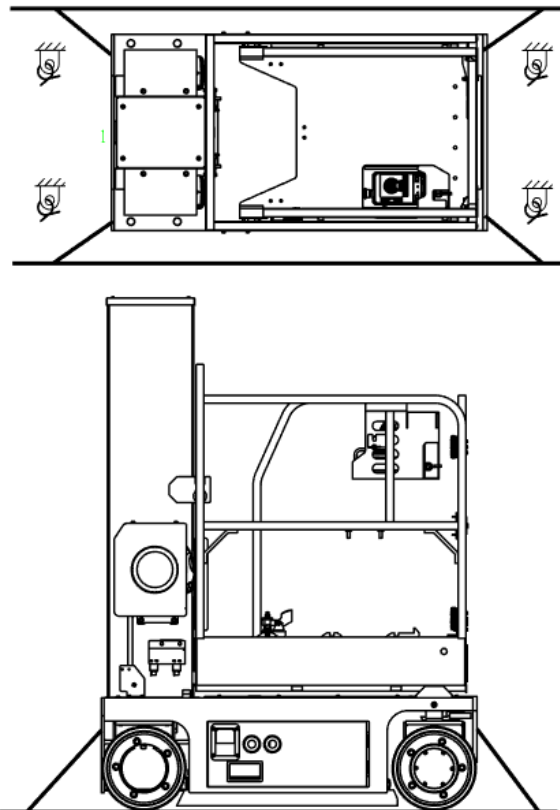

**Figure 4-6 Tie down point**

### 4.10.3 Lifting operation

#### **⚠WARNING**

- a) Obey following regulations:
  - 1) Only qualified riggers can assemble riggers and lift machines;
  - 2) Only qualified forklift operators can lift machines with forklifts;
  - 3) Ensure that the lifting capacity of the crane, loading surface, belt or rope are sufficient to support the weight of the machine. See the serial label for the maximum rated load.
- b) Lift machine with forklift:
  - 1) Ensure that the expansion platform, controller and component tray are safe and reliable, and remove all loose parts from the machine;
  - 2) Fully lower the platform, which must remain lowered during all shipments;
  - 3) Use the forklift slots on both sides of the ladder, as shown in Figure 4-7.

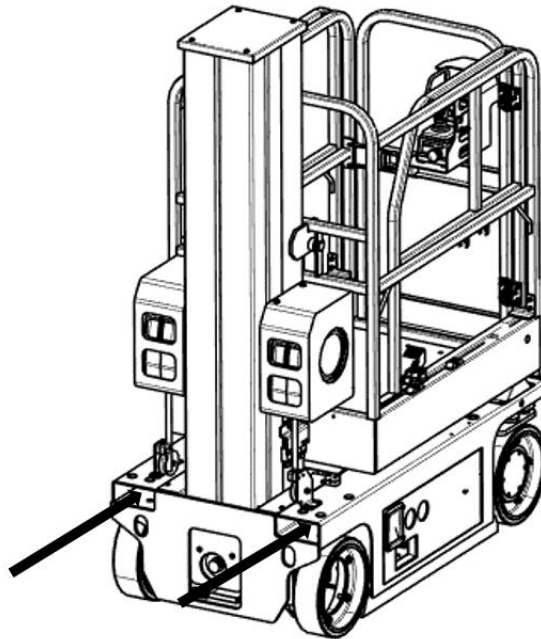

Figure 4-7 Forklift truck slot

- 4) Align the fork of the forklift with the position with the fork notch, and drive forward until the fork is completely inserted;
  - 5) Raise the machine by 0.4m/1ft 4in, then tilt the fork back slightly to keep the machine fixed;
  - 6) Make sure the machine is level when lowering the fork.
- c) Lifting instruction:

- 1) Fully lower the platform to ensure the safety and reliability of the expansion platform, controller and component disk. Remove all loose parts from the machine;
- 2) Use Table 4-7 and Figure 4-8 to determine the center of gravity of the machine.
- 3) Rigging can only be connected to the lifting points specified on the machine. There are two 2.5cm/1in holes on the front panel and the back panel of the machine, which are used for lifting;
- 4) Adjust rigging to avoid damage and maintain machine level.

**Table 4-7 Center of Gravity**

Model	X axis	Y axis
ZMP06	39.0cm/1ft 3in	55.5cm/1ft 9in
ZMP05	39.4 cm/1ft 4in	56.5 cm/1ft 10in
ZMP04	43.3 cm/1ft 5in	47.3 cm/1ft 6in

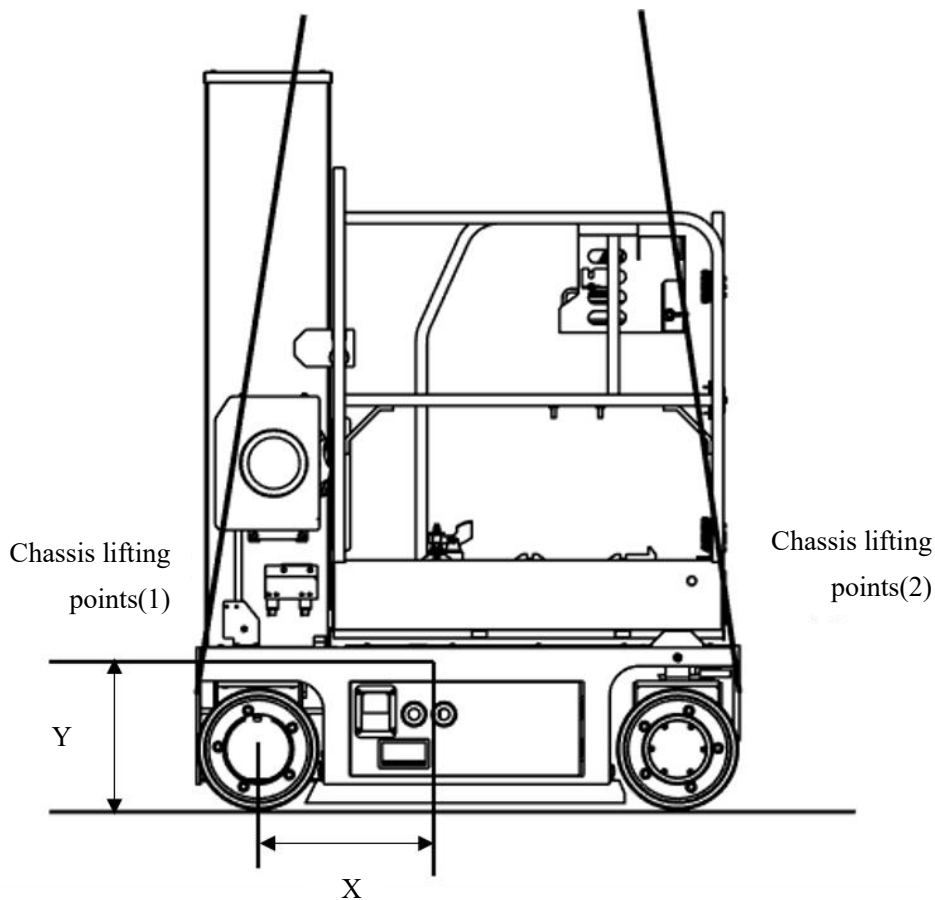
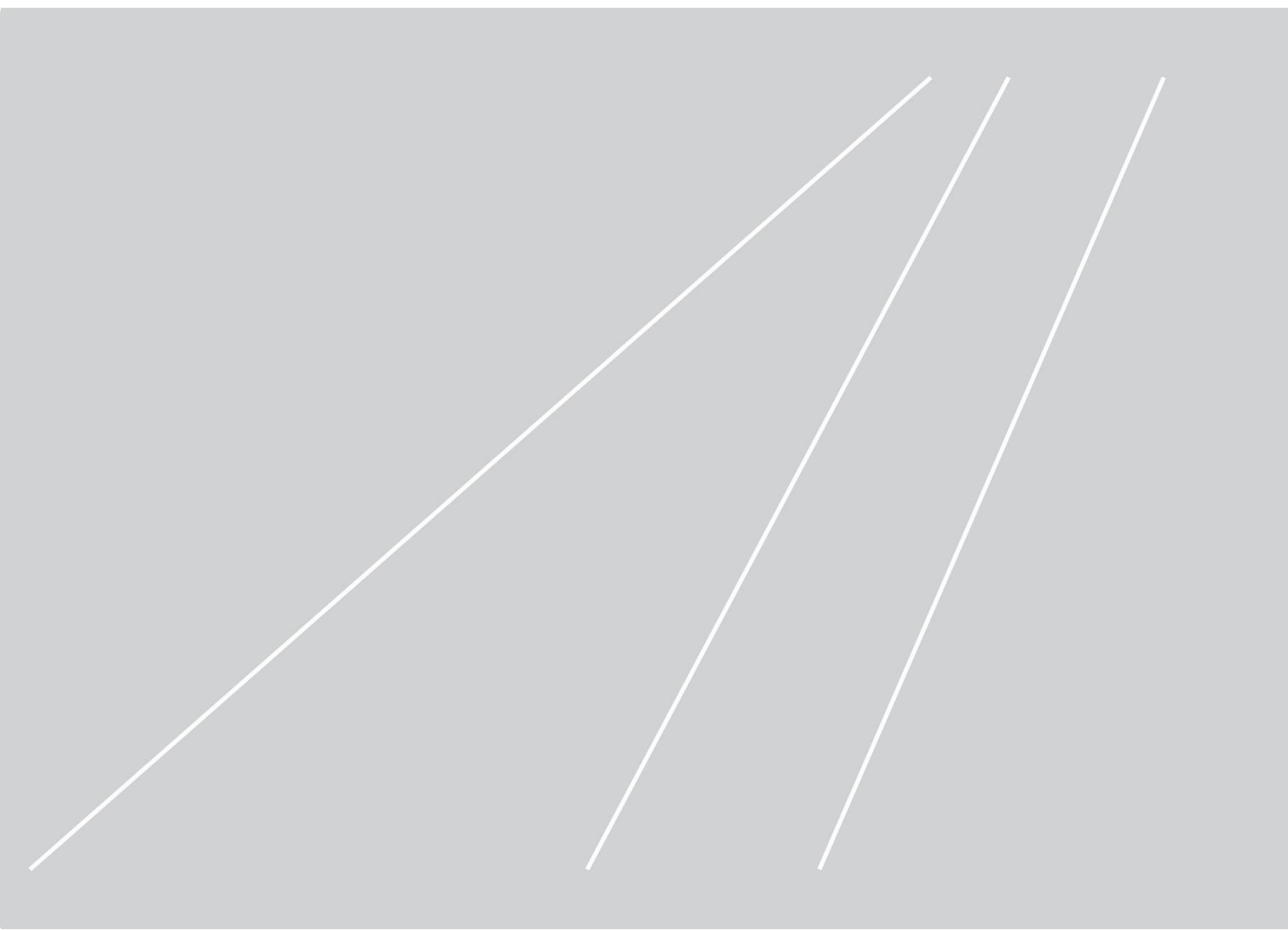

**Figure 4-8 CG position**

# **ZOOMLION**

Operation and Safety Manual

Section 5 Maintenance





## SECTION 5 MAINTENANCE

### 5.1 General



Observe and Obey:

- a) Only routine maintenance items specified in this manual shall be performed by the operator.
- b) Scheduled maintenance inspections shall be performed by qualified service technicians, according to the manufacturer's specifications and the requirements listed in the responsibilities manual.
- c) Disposal of materials should be according to the regulations of government and relevant environmental protection administration.
- d) Use only ZOOMLION approved replacement parts. ZOOMLION assumes no responsibility for hazards occurred to equipment and personnel caused by the use of unauthorized parts.

#### 5.1.1 Maintenance Symbols Legend

The following symbols have been used in this manual to help communicate the intent of the instructions. When one or more of the symbols appear at the beginning of a maintenance procedure, it conveys the meaning below.



Indicates that tools are needed to execute this program.



Indicates that a new part is required to execute this program.

#### 5.1.2 Pre-Start Inspection

- a) Be sure operator's, safety, and responsibilities manuals are complete, legible, and in the storage container located on the machine.
- b) Be sure all decals are in place and legible.
- c) Check for hydraulic oil leaks and proper oil level. Add oil if needed. See Inspections section.
- d) Check for battery fluid leaks and proper fluid level. Add distilled water if needed after battery charged.

Check the following components or areas for damage, improperly installed, or missing parts and unauthorized modifications:

- 1) Electrical components, wiring, and electrical cables.
- 2) Hydraulic hoses, fittings, cylinders, and manifolds.
- 3) Drive motor/motor.
- 4) Wear slider and liner.
- 5) Tire and wheel;
- 6) Limit switches, alarm and horn.
- 7) Alarm and indicator (if equipped).
- 8) Nuts, bolts and other fasteners.
- 9) Brake release unit.

### 5.1.3 Maintenance hazards

- a) Shut off power to all controls and ensure that all moving parts are secured from inadvertent motion prior to performing any adjustments or repairs.
- b) Never work under an elevated platform until it has been fully lowered to the full down position, if possible, or otherwise supported and restrained from movement with appropriate safety props, blocking, or overhead supports.
- c) DO NOT attempt to repair or tighten any hydraulic hoses or fittings while the machine is powered on or when the hydraulic system is under pressure.
- d) Always relieve hydraulic pressure from all hydraulic circuits before loosening or removing hydraulic components.
- e) DO NOT use your hand to check for leaks. Use a piece of cardboard or paper to search for leaks. Wear gloves to help protect hands from ejective hydraulic oil.



### 5.1.4 Body injury hazard

Do not operate a machine with a hydraulic oil or air leak. An air leak or hydraulic leak can penetrate and/or burn skin. During or after a period of running of the hydraulic system, the parts may produce high surface temperature, and improper contact will cause burn to skin. Overhauling or adjusting any part of hydraulic system can cause serious injuries. Only trained maintenance personnel are allowed to repair or adjust the hydraulic system.

Access by the operator is only advised when performing a pre-operation inspection. All

compartments must remain closed and locked during operation.

## 5.2 Hydraulic system maintenance



### 5.2.1 Check hydraulic oil level

Maintaining the hydraulic oil at the proper level is essential to machine operation. Improper hydraulic oil levels can damage hydraulic components. Daily checks allow the inspector to identify changes in oil level that might indicate the presence of hydraulic system problems.

- a) Be sure the machine is on a firm and level surface and in stowed position.
- b) By observing oil level in hydraulic oil tank, the hydraulic oil level after excluding air in the hydraulic system should reach the maximum scale mark on the hydraulic oil tank, and not be higher than bottom of the oil tank cap (different models have different max value).
- c) Add oil as needed. Do not overfill.

### 5.2.2 Hydraulic oil capacity

Table 5-1 Capacity

Model	Hydraulic tank	Hydraulic system (including tank)
ZMP04、ZMP05、ZMP06	5L/1.3 US gal	4.6L/1.22 US gal

### 5.2.3 Hydraulic Oil Specification

Hydraulic oil For details about the type and model, see Table 5-2 Technical parameters of hydraulic oil (not for the specified hydraulic oil model and parameters). Select the appropriate brand and technical parameters of hydraulic oil based on the specific environment of the device. For special environments or users' special requirements, contact ZOOMLION or the manufacturer of hydraulic oil.

#### **CAUTION**

Please do not mix different brands or types of oil, as the mixing of additives in different oils can cause negative effects. If hydraulic oil mixing is unavoidable, it must be allowed by the hydraulic oil manufacturer. Our after-sales service does not cover use failures due to oil mixing.

**Table 5-2 Technical Parameters of Hydraulic Oil**

Brand \ Technical Parameter	ISO Viscosity Grade	Pour Point °C /°F	Flash Point °C /°F	kinematic viscosity cSt (40°C/104°F)	Viscosity index
Great Wall 4632 grease non-flammable hydraulic oil N32 (Eco-Friendly)	32	-20/-4	270/518	28.8-35.2	180
Great Wall Ground 10 aviation hydraulic fluid	—	-55/-67	107/225	<b>10.53</b> (50°C/122°F)	120
Great Wall ZhuoLi L-HS 15 Ultra-low temperature hydraulic oil	15	-57/-71	164/327	15.35	172
Great Wall ZhuoLi L-HS 32 Ultra-low temperature hydraulic oil	32	-48/-54	224/435	31.35	166
Great Wall ZhuoLi L-HS 46 Ultra-low temperature hydraulic oil	46	-43/-45	238/460	45.81	170
Great Wall ZhuoLi L-HV 15 Low temperature hydraulic oil	15	-45/-49	173/343	15.51	140
Great Wall ZhuoLi L-HV 32 Low temperature hydraulic oil	32	-39/-38	231/448	33.4	150
Great Wall ZhuoLi L-HV 46 Low temperature hydraulic oil	46	-37/-35	240/464	48.7	150
Great Wall ZhuoLi L-HV 68 Low temperature hydraulic oil	68	-35/-31	238/460	70.47	150

**Table 5-2 Technical Parameters of Hydraulic Oil (cont.)**

<b>Brand</b>	<b>Technical Parameter</b>	<b>ISO Viscosity Grade</b>	<b>Pour Point °C /°F</b>	<b>Flash Point °C /°F</b>	<b>kinematic viscosity cSt (40°C/104°F)</b>	<b>Viscosity index</b>
<b>Great Wall ZhuoLi L-HM 46</b>	<b>Anti-wear hydraulic oil (high pressure)</b>	46	-15/5	240/464	45.8	97
<b>Great Wall ZhuoLi L-HM 68</b>	<b>Anti-wear hydraulic oil (high pressure)</b>	68	-13/9	245/473	67.4	98
<b>Mobil SHC Aware H 32 (Eco-Friendly)</b>		32	-30/-22	185/365	32	140
<b>Clarity Synthetic EA Hydraulic Oil</b>		46	-44/-47	221/430	46	180
<b>Mobil DTE 10 Ultra 22</b>		22	-54/-65	224/435	22.4	164
<b>Mobil DTE 10 Ultra 32</b>		32	-54/-65	250/482	32.7	164
<b>Mobil DTE 10 Ultra 46</b>		46	-45/-49	232/450	45.6	164
<b>CaltexRando Rando HDZ 15</b>		15	-60/-76	150/302	15.7	144
<b>CaltexRando Rando HDZ 32</b>		32	-49/-56	204/399	33	150
<b>CaltexRando Rando HDZ 46</b>		46	-47/-53	216/421	46.7	153
<b>CaltexRando Rando MV 15</b>		15	-42/-44	154/309	15.8	155
<b>CaltexRando Rando MV 32</b>		32	-36/-33	210/410	33.5	154
<b>CaltexRando Rando MV 46</b>		46	-33/-27	214/417	44	154

**5.2.4 Hydraulic Oil Viscosity and Temperature Limit**

Proper use of hydraulic oil: please note the corresponding oil viscosity and temperature limit. Under normal working conditions, the recommended oil temperature should be controlled at 30°C/86°F to 60°C/140°F, when the oil temperature exceeds 90°C/194°F, please stop using the equipment. The oil

temperature affects the oil viscosity and the thickness of the oil film. Excessive oil temperature can also damage or shorten the life of the oil seal and other rubber components, which will cause oil leakage in the hydraulic system, and high temperature will exacerbate the evaporation and oxidation of the oil.

Pre-delivery of the machine, specific model of hydraulic oil shall be added as required by customer. If machine operating environment temperature is beyond the temperature limit of the hydraulic oil, different hydraulic oil suited to the actual conditions shall be used in time. On account of the safety of machine components and work efficiency, it is advisable that the starting temperature should be 25°C/77°F higher than the pour point of hydraulic oil.

If the equipment is used at an altitude of more than 4000 m/13100 ft, in order to ensure the normal oil absorption of the hydraulic pump, please use a lower viscosity grade of hydraulic oil on the basis of meeting the requirements for the use of hydraulic oil.

### 5.2.5 Changing Hydraulic Oil

We suggest that changing time of the hydraulic oil is as follows:

- a) First changing: Operating for 500 hrs after debugging.
- b) Second and subsequent changing: Every 2,000 hrs of operation or once a year.

The above recommended intervals are suitable for most applications. Higher temperatures and pressures will shorten the oil's service life, so the hydraulic oil should be changed sooner than the recommended. For small load work, the oil change time can be extended.

Cleanliness of the hydraulic oil upon delivery is NAS9 (ISO4406 18/15), and for normal operation, the cleanliness should not be lower than NAS10 (ISO4406 19/16). We suggest that the hydraulic oil should be checked every 6 months, and the oil should be sampled at least once upon the time for oil changing. The oil sample can be sent to the hydraulic oil manufacturer or qualified third-party testing agency for analysis and to determine whether it is still usable.

### 5.2.6 Changing Oil Return Filter

Return oil filter element It is recommended to replace it every 1000 hours or once a year, whichever comes first. A good working return filter element is very important to the performance and service life of the machine. Dirty or clogged filters will affect machine performance and damage components. Under hostile environment and bad operating conditions, the filter should be checked and replaced more frequently.

## 5.3 Battery Maintenance



Proper battery condition is essential to good machine performance and operational safety. Improper fluid levels or damaged cables and connections can result in component damage and hazardous conditions.

Note: this inspection is not required for machines with sealed or non-maintainable batteries.

Check electrolyte level of the battery every two weeks. Fully charge the battery before adding water. If the electrolyte level is much higher than the plate, then no need to add water.

### **▲WARNING**

Electric shock hazard : Exposure to electrical circuits may result in death or serious injury. Remove all rings, watches and other accessories.

Body injury hazard : Batteries contain acidic substances. Avoid leakage of acidic substances from batteries or contact with them. Use soda and water to neutralize spilled battery acid. Avoid spilling or contacting battery acid.

After the battery is fully charged, check as follows.

- a) Wear protective clothing and glasses;
- b) Ensure that the battery cable is securely connected and not corroded;
- c) Ensure that the battery locking bracket is properly and securely positioned.

Adding terminal protectors and anti-corrosion sealants will help eliminate corrosion to battery terminals and cables.

## **5.4 Regular Maintenance**

- a) Maintenance performed quarterly, annually and every two years must be completed by a person trained and qualified to perform maintenance on this machine according to the procedures found in the service manual for this machine.
- b) Machines that have been out of service for more than three months must receive the quarterly inspection before they are put back into service.
- c) By observing oil level in hydraulic oil tank, the hydraulic oil level after excluding air in the hydraulic system should reach the maximum scale mark on the hydraulic oil tank, and not be higher than bottom of the oil tank cap (different models have different max value).
- d) Add oil as needed. Do not overfill.
- e) Torque check of tire mounting bolts on a quarterly basis.



# ZOOMLION

Operation and Safety Manual

Section 6 Storage and Ex-factory  
Test

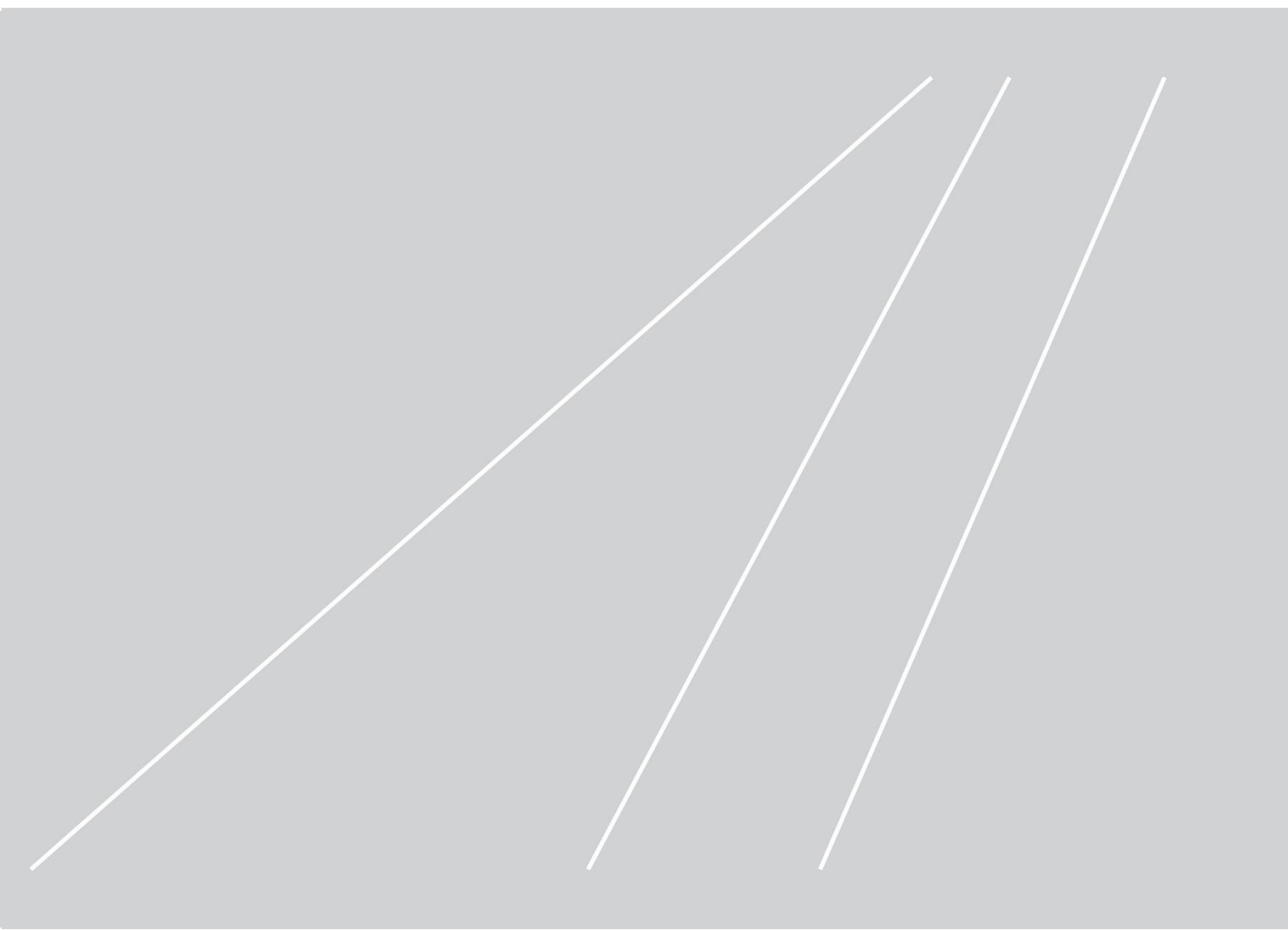



## SECTION 6 STORAGE AND EX-FACTORY TEST

### 6.1 Storage Conditions

Ambient temperature for machine storage and transportation should be between -20°C/-4°F and 40°C /104°F, with relative humidity not greater than 85% and 100% only for short-term.

### 6.2 Ex-factory Test Items

Machine must complete testing items in the following table before delivery:

**Table 6-1 Ex-factory test items (ZMP04/ZMP05)**

Test type	Load test		Movement
Overload test	125%	287 kg/632 lbs	Platform Lifting
Functional test	110%	253 kg/558 lbs	Traveling & Platform Lifting
Brake test	100%	230 kg/510 lbs	Max Speed of Forward & Reverse Traveling

**Table 6-2 Ex-factory test items (ZMP06)**

Test type	Load test		Movement
Overload test	125%	250 kg/551 lbs	Platform Lifting
Functional test	110%	220 kg/485 lbs	Traveling & Platform Lifting
Brake test	100%	200 kg/440 lbs	Max Speed of Forward & Reverse Traveling



# **ZOOMLION**

Operation and Safety Manual

Section 7 Technical Parameters





## SECTION 7 TECHNICAL PARAMETERS

Table 7-1 ZMP06 Technical Parameter

Model	ZMP06	Technical Parameter	
Specification Size	Max work height	7.9 m	25ft 11in
	Platform Height	5.9 m	19ft 4in
	Max work height when stowed	1.99 m	6ft 6in
	Max platform height when stowed	0.74 m	2ft 5in
	Guardrail height	1.12 m	3ft 8in
	Stowed width	0.78 m	2ft 6in
	Stowed length	1.39 m	4ft 6in
	Extension deck	0.5 m	1ft 7in
	Platform Size (length * width)	1.02*0.76 m	3ft 4in*2ft 6in
	Wheelbase	1.06 m	3ft 6in
	Min ground clearance	0.065 m	2.5in
	Pit protection deployed	0.017 m	0.65in
Work Performance	Rated load	200 kg	440 lbs
	Max number of operator	1 personnel indoor	
	Driving speed (max value - stowed)	4 km/h	2.5mph
	Driving speed (max value - raised)	0.5 km/h	3.1mph
	Maximum slope rating, stowed position	25% (14°)	
	Max lateral slope rating, stowed position	25% (14°)	
	Max chassis slope (vertical/lateral)	3 ° / 1.5 °	
	Rotating radius (outside)	1.43 m	4ft 8in
	Rotating radius (inside)	0.14 m	5.5 in
	Total amount of vibration sustained by the hand/arm system	≤2.5 m/s	≤5.6 mph
Maximum square root value of the weighted acceleration experienced by the entire fuselage	≤0.5 m/s <sup>2</sup>	≤1ft 8in/s <sup>2</sup>	

**Table 7-1 ZMP06 Technical Parameter (cont.)**

Model	ZMP06	Technical Parameter	
<b>Work Environment</b>	Max. Wind Speed	0 m/s	0mph
	Lowest temperature	-20 °C	-4°F
	Highest temperature	60°C	140°F
	Sound pressure level in surface work area	<70 dBA	
	Sound pressure level of platform working area	<70 dBA	
<b>Other</b>	Gross weight	1085 kg	2392 lbs
	Power	2 packs of battery, 12V/120AH	
	System voltage	24V	
	Platform AC power socket	Standard	
	Max hydraulic pressure (function)	240 bar	3480psi
	Tire size	Φ323mm × 100mm	Φ13in × 4in
	Max tire load	660 kg	1455 lbs
	Tyre contact pressure	7.42 kg/cm <sup>2</sup>	106psi
	Ground pressure	0.1 kg/cm <sup>2</sup>	1.4psi
	Pump motor power	2.5kw	3.35hp

**Table 7-2 ZMP05 Technical Parameter**

Model	ZMP05	Technical Parameter	
<b>Specification Size</b>	Max work height	6.9 m/5.8 m	22ft 7in/19ft
	Platform Height	4.9 m/3.8 m	16ft 1in/ 12ft 6in
	Max work height when stowed	1.99 m	6ft 6in
	Max platform height when stowed	0.51 m	1ft 8in
	Guardrail height	1.12 m	3ft 8in
	Stowed width	0.77 m	2ft 7in
	Stowed length	1.46 m	4ft 9in
	Extension deck	0.5 m	1ft 7in
	Platform Size (length * width)	1.05*0.76 m	3ft 5in*2ft 6in
	Wheelbase	1.12 m	3ft 8in
	Min ground clearance	0.065 m	2.5 in
	Pit protection deployed	0.017 m	0.65 in
	<b>Work Performance</b>	Rated load	230 kg
Max number of operator (indoor/outdoor)		1/1	
Driving speed (max value - stowed)		4 km/h	2.5mph
Driving speed (max value - raised)		0.5 km/h	3.1mph
Maximum slope rating, stowed position		25% (14°)	
Max lateral slope rating, stowed position		25% (14°)	
Max chassis slope (vertical/lateral)		3 ° / 1.5 °	
Rotating radius (outside)		1.52 m	4 ft 11 in
Rotating radius (inside)		0.23 m	9 in
Total amount of vibration sustained by the hand/arm system		≤2.5 m/s	≤5.6 mph
Maximum square root value of the weighted acceleration experienced by the entire fuselage		≤0.5 m/s <sup>2</sup>	≤1 ft 8 in/s <sup>2</sup>

**Table 7-2 ZMP05 Technical Parameter (cont.)**

Model	ZMP05	Technical Parameter	
<b>Work Environment</b>	Max. Wind Speed	12.5 m/s	28 mph
	Lowest temperature	-20 °C	-4°F
	Highest temperature	60°C	140°F
	Sound pressure level in surface work area	<70 dBA	
	Sound pressure level of platform working area	<70 dBA	
<b>Other</b>	Gross weight	960 kg	2120 lbs
	Power	2 packs of battery, 12V/120AH	
	System voltage	24V	
	Platform AC power socket	Standard	
	Max hydraulic pressure (function)	240 bar	3480psi
	Tire size	Φ323mm × 100mm	Φ13in × 4in
	Max tire load	575 kg	1268 lbs
	Tyre contact pressure	6.94 kg/cm <sup>2</sup>	98.7psi
	Ground pressure	0.09 kg/cm <sup>2</sup>	1.3psi
	Pump motor power	2.5kw	3.35hp

**Table 7-3 ZMP04 Technical Parameter**

<b>Model</b>	<b>ZMP04</b>	<b>Technical Parameter</b>	
<b>Specification Size</b>	Max work height	5.8 m	19ft
	Platform Height	3.8 m	12ft 5in
	Max work height when stowed	1.72 m	5ft 7in
	Max platform height when stowed	0.6 m	1ft 11in
	Guardrail height	1.12 m	3ft 8in
	Stowed width	0.78 m	2ft 6in
	Stowed length	1.39 m	4ft 6in
	Extension deck	0.5 m	1ft 7in
	Platform Size (length * width)	1.02*0.76 m	3ft 4in*2ft 6in
	Wheelbase	1.06 m	3ft 6in
	Min ground clearance	0.065 m	2.5 in
	Pit protection deployed	0.017 m	0.65 in
<b>Work Performance</b>	Rated load	230 kg	510 lbs
	Max number of operator (indoor/outdoor)	2/1	
	Driving speed (max value - stowed)	4 km/h	2.5mph
	Driving speed (max value - raised)	0.5 km/h	3.1mph
	Maximum slope rating, stowed position	25% (14°)	
	Max lateral slope rating, stowed position	25% (14°)	
	Max chassis slope (vertical/lateral)	3 ° / 1.5 °	
	Rotating radius (outside)	1.43 m	4 ft 8 in
	Rotating radius (inside)	0.14 m	5.5 in
	Total amount of vibration sustained by the hand/arm system	≤2.5 m/s	≤5.6 mph
Maximum square root value of the weighted acceleration experienced by the entire fuselage	≤0.5 m/s <sup>2</sup>	≤1 ft 8 in/s <sup>2</sup>	

**Table 7-3 ZMP04 Technical Parameter (cont.)**

Model	ZMP04	Technical Parameter	
<b>Work Environment</b>	Max. Wind Speed	12.5 m/s	28 mph
	Lowest temperature	-20 °C	-4°F
	Highest temperature	60°C	140°F
	Sound pressure level in surface work area	<70 dBA	
	Sound pressure level of platform working area	<70 dBA	
<b>Other</b>	Gross weight	900 kg	1984 lbs
	Power	2 packs of battery, 12V/120AH	
	System voltage	24V	
	Platform AC power socket	Standard	
	Max hydraulic pressure (function)	240 bar	3480psi
	Tire size	Φ323mm × 100mm	Φ13in × 4in
	Max tire load	528 kg	1164 lbs
	Tyre contact pressure	6.62 kg/cm <sup>2</sup>	94psi
	Ground pressure	0.09 kg/cm <sup>2</sup>	1.3psi
	Pump motor power	2.5kw	3.35hp

## **DISPOSAL**

**a) Service life**

For 10 years.

Please doing complete inspection for every 5years.

**b) Disposal**

If the MEWP cannot be repaired, please follow your national regulation to dispose the MEWP.







# Self-propelled Vertical Mast lifts Operation and safety manual

**ZOOMLION INTELLIGENT ACCESS MACHINERY CO.,LTD.**

Add. 701 Xulong Nan Lu, Xiangjiang New District, Changsha, Hunan, China

Zip Code:410005

E-mail:awm@zoomlion.com

Tel:400-800-0157



**ZOOMLION**