



Operation Manual

EN 280:2013+A1:2015

T20J/T22J

T26J

**Mobile Elevating
Work Platforms**

PART No. OM- 2537050084

Original Instructions

Original Instructions

Thank you for choosing to use this Mobile Elevating Work Platform from LGMG, All models are designed and manufactured according to EN 280:2013+A1:2015, All dealers, owners, users, operators, lessors, lessees, and brokers to comply with appropriate section(s) of applicable EN 280:2013+A1:2015 standards.

This manual is a guide for safe and proper operation and maintenance of the machine, which introduces technical parameters and mechanism and operation herein.

We sincerely hope that you will read through this manual before attempting to operate the machine for the first time and before repairing and maintaining the machine, and that you will master the operation and maintenance described therein.

The information contained in this manual is correct at the time of publication. However, LGMG has endeavored to deliver the highest degree of accuracy possible. And continuous improvement of our product is a LGMG policy. Therefore, product specifications are subject to change without notice.

Due to the impossibility of foreseeing all possible hazards, therefore, it is not possible to include all safety precautions in this manual and the machine's safety precautions in this manual and the machine's safety instructions. If some operations that are not recommended in this manual, you must ensure that you and others are safe and will not damage the machine. If the security of certain operations cannot be determined, please call LGMG industries or dealer service center.

The precautions for operation and maintenance contained in this manual are only applicable when the machine is used for the specified use. If the machine is used within the scope not listed in this manual, our company will not accept any safety responsibility, which is borne by the user and operator in such operations.

Any prohibited operations in this manual shall not be performed.

This manual should always be placed in the designated location for read. This manual is part of the machine, when the ownership or use right of the machine is transferred, please hand over this manual together. If the manual is lost, damaged or illegible, please replace it promptly.

The copyright of this manual this manual is authorized to LGMG and it cannot be copied or reprinted without LGMG's written permission.

2025-06 Version 1 Printed 1

LINGONG HEAVY MACHINERY CO., LTD.

Add: 2676 Kejia Road, high tech Zone, Jinan City, Shandong Province, China

Tel: 86-0531-67601108

Fax: 86-0531-67601108

Service Tel: 86-0531-67605016

Web: www.lgmg.com.cn



Contents

Contents.....	I
Safety Precautions	III
Chapter 1 Safety	2
1.1 Danger	4
1.2 Before Operating the Machine, Please Ensure that:	4
1.3 Classification of Dangers	4
1.4 Purpose	4
1.5 Maintenance of Safety Signs	5
1.6 Danger of Electric Shock.....	5
1.7 Danger of Tilting	5
1.8 General Safety	6
1.9 Danger of Operating the Machine on Slopes	7
1.10 Danger of Falling	7
1.11 Danger of Collision.....	8
1.12 Dangers of Explosion and Fire	8
1.13 Danger of Damage to the Machine.....	8
1.14 Danger of Body Injury	9
1.15 Battery Safety	9
1.16 Personal Fall Protection	9
1.17 Ground Information.....	10
Chapter 2 Legend.....	12
Chapter 3 Decals	16
Chapter 4 Machine Specifications	22
Chapter 5 Control Box.....	48
5.1 Lower Control Box.....	50
5.2 Upper Control Box.....	57
5.3 Control Logic (SPD)	63
Chapter 6 Pre-Operational Check.....	64
6.1 Before Operating the Machine, Please Ensure that:	66
6.2 Basic Principles	66
6.3 Pre-Operational Check	66
6.4 Pre-operation Inspection of Safety Protection Devices (SPD)	67
6.5 Machine inspection diagram.....	68



Chapter 7 Workplace Inspection	72
7.1 Basic Principles	74
7.2 Workplace Inspection	74
Chapter 8 Functional Test	76
8.1 Basic Principles	78
8.2 At the Ground Controller	78
8.3 On the Platform	78
8.4 Verification Procedures for Safety Protection Devices (SPD)	81
Chapter 9 Operation Instructions	82
9.1 Basic Principles	84
9.2 Starting up the Engine.....	84
9.3 Emergency Shutdown	84
9.4 Auxiliary Power.....	84
9.5 Operating the Machine on Ground.....	85
9.6 Operating the Machine on the Platform.....	85
9.7 Platform Overload.....	87
9.8 Non-Level State of the Machine	87
9.9 System Fault	87
9.10 Function of Safety Protection Devices (SPD)	90
9.11 DPF Instructions	90
9.12 Upon Every Use	92
Chapter 10 Transport Description	94
10.1 Compliance and Obedience.....	96
10.2 Brake Release when Using the Capstan	96
10.3 Ensuring Transport Safety	96
10.4 Guidance on Lifting the Machine	97



Safety Precautions

The operator of this machine shall understand and follow the existing safety regulations of state and local governments. If these are unavailable, the safety instructions in this manual shall be followed.

To help prevent accidents, read and understand all warnings and precautions in this manual before operation or performing maintenance.

The safety measures are specified in Chapter 1 Safety.

It is impossible to foresee every possible hazard and the safety instructions in this manual may not cover all safety prevention measures. Always ensure the safety of all personnel and protect the machine against any damage. If unable to confirm the safety of some operations, contact LGMG.

The operation & maintenance prevention measures listed in this manual are only applicable to the specified uses of this machine. LGMG assumes no responsibility if this machine is used beyond the range of this manual. The user and the operator shall be responsible for the safety of such operations.

Do not perform any operation forbidden in this manual in any situation.

The following signal words are applicable for identifying the level of safety information in this manual.

DANGER:

An imminent situation, that if not avoided, will result in severe injuries or death. This is also applicable to situations that will cause serious machine damage, if not avoided.

WARNING:

A potentially dangerous situation, that if not avoided, may result in severe injuries or death. This is also applicable to situations that may cause serious machine damage, if not avoided.

NOTICE:

A situation, that if not avoided, may result in minor or intermediate injury. This is also applicable to situations that may cause machine damage or shorten machine service life.



**Operation Manual of Telescopic Boom
Mobile Elevating Work Platform**



Chapter 1 Safety



**Operation Manual of Telescopic Boom
Mobile Elevating Work Platform**



1.1 Danger



WARNING: Failure to follow the

instructions and safety rules in this manual may result in serious injury or death. Alcoholics, drug users, and those who take anti-reactive drugs are strictly prohibited from approaching and operating the machine.

1.2 Before Operating the Machine, Please Ensure that:

- 1) You are equipped with full-body protective equipment such as helmets, safety belts, safety shoes, goggles and protective gloves, and are in good physical condition.
- 2) You have understood and practiced the safety rules for machine operation in this operation manual.
- 3) You know and understand the rules for safe operation of the machine before proceeding to the next step.
- 4) You always perform pre-operational checks.
- 5) You always perform pre-use functional tests.
- 6) You check the workplace.
- 7) You use the machine for the specified purpose only.
- 8) You read, understand and abide by all applicable laws and regulations.
- 9) You have been trained to operate the machine safely.

1.3 Classification of Dangers



NOTICE

Classification of hazards

The meanings of symbols, color codes and characters of LGMG's products are as follows:

Security warning symbol: Are used for warning of potential personal injuries.

Observe all safety instructions below these signs, to avoid situations causing potential personal injury and death.



Red: Signifies dangerous situations. If not avoided, will result in personal death or severe injury.



Orange: Signifies dangerous situations. If not avoided, may result in personal death or severe injury.



Yellow: Signifies dangerous situations. If not avoided, may result in minor or intermediate personal injury.

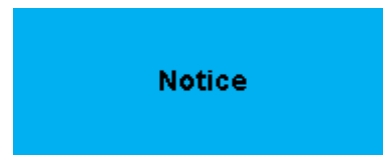

Blue: Signifies dangerous situations. If not avoided, property loss or damage can occur.

1.4 Purpose

The purpose of this machine is limited to lifting personnel and their tools and materials to high-altitude workplaces, and it can be used indoors and outdoors.



WARNING: It is strictly forbidden



to modify the machine without permission, to carry goods, and to hang or lift articles.

1.5 Maintenance of Safety Signs

- 1) Replace lost and damaged safety signs.
- 2) Clean the safety signs with a neutral detergent or water.
- 3) Solvent-based detergents may damage the safety signs. Do not use solvent-based detergents to clean the safety signs.

1.6 Danger of Electric Shock



WARNING: This machine is not

insulated and does not provide protection against electric shock when in contact with or near electrical wiring, power source or electrical equipment.



Please maintain an adequate safety distance from electrical wiring, power source and electrical equipment in accordance with applicable laws and regulations and the instructions in the following table.

Voltage	Required safety distance
0-300 V	No touching.
300V-50 KV	3.05m
50 KV-200 KV	4.60m
200 KV-350 KV	6.10m
350 KV-500 KV	7.62m
500 KV-750 KV	10.67m
750 KV-1,000 KV	13.72m

Table 1-1 Safe distance between the equipment

and power line



CAUTION: The effects of strong

winds or gusts on the movement of the platform, the swinging and slackening of the wires shall be taken into account.

- 1) If the machine comes into contact with a live wire, get away from the machine immediately. Personnel are prohibited from touching or operating the machine before cutting off the power to the wires.
- 2) Do not operate or use the machine during lightning or storms.
- 3) Do not use the machine as a ground wire during welding.

1.7 Danger of Tilting

- 1) The personnel, equipment and materials on the platform shall not exceed the maximum load capacity of the platform.

Item	T20J	T22J	T26J
Maximum Load Capacity of the Platform	250kg	300kg	250kg
		450kg (Restricted range of motion)	340kg (Restricted range of motion)
Maximum occupants	2	2	2
		3 (Restricted)	3 (Restricted)
Maximum Allowable Wind Speed	12.5m/s		

Table 1-2 Maximum load capacity of the platform

- 2) If the platform is overloaded, the buzzer will alarm. Please reduce the platform load first.
- 3) When the platform is lifted, the driving speed should not exceed 0.8km/h.
- 4) The tilt angle sensor cannot be used as a level indicator. The buzzer on the turntable will only sound when the machine is heavily



Operation Manual of Telescopic Boom Mobile Elevating Work Platform

tilted.

- 5) Please be very careful if the buzzer sounds when the platform is lifted. The machine's non-level indicator will light up and the drive function will not work in either direction. First determine the status of the upper boom on the slope, as shown below. Then follow the steps below to descend the boom before moving the machine to a solid and level ground. Do not rotate the boom when descending.

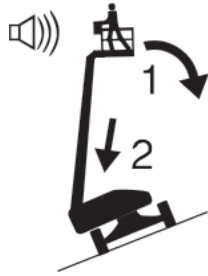

- 6) If the buzzer sounds when the platform goes up the slope

- ① Lower the boom
- ② Retract the boom

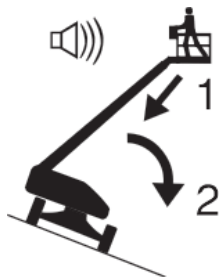

- 7) If the buzzer sounds when the platform goes down the slope

- ① Retract the boom
- ② Lower the boom



- 8) Do not lift the boom when the wind speed may exceed 12.5 m/s. If the wind speed exceeds 12.5 m/s after the boom is lifted, lower the boom and do not continue to operate the machine.

- 9) Do not operate the machine in strong winds or gusts. Do not increase the surface area of the platform or load. Increasing the area exposed to the wind will reduce the stability of the machine.
- 10) Do not use the upper control box to operate the machine when the platform is trapped, jammed, or other objects nearby are blocking its normal movement. If you plan to operate the machine with the lower control box, all personnel must leave the platform before you do so.
- 11) In the retracted state, please be very careful and reduce the speed when the machine is running on gravels, unstable or smooth surfaces and near the entrance of the cave or steep slopes.



- 12) When the boom is lifted, the machine cannot run on uneven terrain, unstable surfaces, or other dangerous conditions, or run near these areas.
- 13) Do not push or pull anything outside the platform.
- 14) Do not use the machine as a crane.
- 15) Do not place, tie or hang loads on any part of the machine.
- 16) Do not use the boom to push a machine or other objects.

1.8 General Safety

- 1) Do not operate the machine with the hood open.
- 2) Do not allow the boom to approach or touch



anything.

- 3) Do not change or use all sensors such as length transducer, tilt angle sensor, the weighing sensor and rope-breaking detection devices.
- 4) Do not bundle the boom or platform to adjacent objects.



- 5) This machine shall not be modified without the prior written permission of the manufacturer. Additional devices installed on platforms, pedals or guardrails for placing tools or materials will increase the weight and surface area of the platform.
- 6) Do not place ladders or scaffolds in the platform or against any part of the machine.
- 7) Only tools and materials that are evenly distributed and can be safely moved by people on the platform can be transported.
- 8) Do not use the machine on moving surfaces or vehicles.
- 9) Do not place your hands and arms near the area where there is a risk of cutting or crushing.
- 10) Do not alter or damage any parts that may affect the safety and stability of the machine.
- 11) Do not replace parts that affect machine stability with parts of different specifications.
- 12) Ensure that all tires are in good condition and the nuts are properly tightened, and do not replace the original tires with tires of different specifications.
- 13) The ambient temperature of the machine is $-20^{\circ}\text{C} \sim 40^{\circ}\text{C}$.
- 14) Ensure that this manual is kept in a file box in the platform.

1.9 Danger of Operating the Machine on Slopes

Do not drive the machine on slopes exceeding the machine's maximum uphill, downhill or side slope ratings. The slope rating applies only to machines that are in the retracted state.

The maximum slope rating for when the boom is retracted is as follows

Downhill	45% (24°)
Uphill	30% (17°)
Side Slope	25% (14°)

Table 1-3 Maximum slope rating for when the boom is retracted

! CAUTION: The slope rating is

limited by ground conditions and traction. Please refer to driving on a slope in the "Operation Instructions" section of this manual.

1.10 Danger of Falling

- 1) In the process of operation, the staff on the platform must wear safety protection equipment such as helmets, safety belts and safety shoes according to the requirements on site, and use, inspect and periodically replace the safety equipment according to the manufacturer's instructions.

! WARNING: The seat belt hooks

must be secured to the approved rope attachment points, and only one hook can be tied to each rope attachment point.



- 2) Do not sit, stand or climb on the guardrail of



Operation Manual of Telescopic Boom Mobile Elevating Work Platform

the platform. Stand steadily on the platform floor at all times.

- 3) When the platform is lifted, do not climb down from the boom.
- 4) Keep the platform floor free of debris and sundries.
- 5) Please close the entrance door before operation.
- 6) Do not enter or exit the platform unless the machine is in a retracted state.

1.11 Danger of Collision

- 1) When operating the machine on the ground, please maintain normal judgment and planning. Maintain a safe distance among the operator, the machine and objects.
- 2) When starting or operating the machine, please pay attention to the range of visibility and blind spots.



- 3) When rotating the turntable, please pay attention to the position of the boom and the tail of the turntable.
- 4) Check the work area to avoid overhead obstacles or other possible hazards.
- 5) When holding onto the platform guardrail, beware of the danger of squeezing.
- 6) Lower the boom only when there are no people or obstacles in the lower area.



- 7) Limit the machine speed according to ground conditions, congestion levels, slope, personnel location and any other factors that may cause a collision.

- 8) Do not operate the machine in the path of any cranes or moving elevated machines unless the crane controller is locked or precautions have been taken to prevent any potential collisions.
- 9) Do not drive dangerously or play while operating the machine.
- 10) Users must follow user rules, workplace rules and government rules for personal protective equipment.
- 11) Please observe the direction of the driving and steering functions.

1.12 Dangers of Explosion and Fire

- 1) Do not start the engine if you smell or notice a leak of liquefied petroleum gas, gasoline, diesel or other explosive materials.
- 2) Do not refuel the machine when the engine is running.
- 3) Refuel the machine and charge the battery only in open and well-ventilated places that are away from sparks, burning cigarettes and other sources of fire.
- 4) Do not use the machine or charge the battery in places that are dangerous or where flammable or explosive gases or dust may exist.
- 5) Do not spray ether into an engine equipped with a glow plug.

1.13 Danger of Damage to the Machine

- 1) Do not use a damaged or faulty machine.
- 2) Do not use the machine as a ground wire during welding, and the battery anode and cathode must be disconnected during welding.
- 3) Do not use the machine in places where strong magnetic fields, strong ionization and radioactive radiation may exist.
- 4) Do not use any battery or charger larger than 12V to start the engine.



- 5) Prior to each shift, please strictly perform pre-operational check and test all functions. A damaged or faulty machine should be marked immediately and stop operation.
- 6) Ensure that all inspections and maintenance have been carried out in accordance with the instructions in this manual.
- 7) Ensure that all labels are properly positioned and easily identifiable.

- The battery pack must be placed vertically.
 - Do not expose batteries or chargers to water or rain.
- 2) Danger of explosion



1.14 Danger of Body Injury



- 1) Please always operate the machine in a well-ventilated area to avoid exhaust poisoning.
- 2) Do not operate the machine when there is hydraulic oil leakage which may penetrate or burn the skin, and always wear safety goggles and protective gloves when checking for hydraulic oil leakage.
- 3) It is forbidden to carry out maintenance work when the equipment is electrically charged or the hydraulic system is under pressure.
- 4) Incorrect contact with any components under the hood can result in serious injuries and only trained maintenance personnel can open the hood for maintenance. The operator may open the hood for inspection only during pre-operational checks. All hoods must remain closed during operation.



- Sparks, flames or ignited cigarettes are prohibited from approaching the battery. The battery may release explosive gases.
 - Do not touch the battery terminals or cable clamps with tools that may cause sparks.
- 3) Danger of electric shock
 - The battery charger can only be connected to a 12V battery charger.
 - Check the cable and wiring for damage daily and replace the damaged items before operation.
 - Avoid electric shock caused due to contact with battery terminals.
 - Remove all rings, watches and other accessories when checking.

1.15 Battery Safety

- 1) Danger of burns
 - The battery is a maintenance-free lead storage battery containing acidic substances. It is forbidden to disassemble the battery case.
 - If the acid in the battery overflows, use soda water to neutralize.

1.16 Personal Fall Protection

- Personal falling protection equipment (PFPE) is required during machine operation.
- Occupants must wear a safety belt or harness in accordance with governmental regulations. Attach the lanyard to the anchor provided in the platform.
- Operators must comply with employer, job site and governmental rules regarding the use of personal



protective equipment.

- All PFPE must comply with corresponding government regulations and must be subject to check and use in accordance with the manufacturer's instructions.

T20J	670	12
T22J	652	14
T26J	899	18

1.17 Ground Information



WARNING: Rollover and personal

injury will be caused under severe working conditions and complex and unsafe ground conditions, and stable ground conditions and good working conditions can ensure the normal operation of the machine; therefore before operation, verify that the ground in the working area is safe and strong enough to support the machine.



DANGER: Rollover and personal

injury may occur under the following conditions:

- On steep slopes or in caves;
- When there are protrusions, obstacles or debris on the ground;
- On the inclined surface;
- On the unstable or smooth surface;
- Near the mining area where the soil foundation is soft soil;
- On saturated soil or frozen soil;
- On suspended floor;
- On kerbs and road edges;
- On surface support that is not strong enough to withstand the full load of the machine;
- Under other possible unsafe situations.

The ground load bearing information of the machine is shown in the table below:

Model	Tire contact pressure (kPa)	Occupied floor pressure (Kpa)
-------	-----------------------------	-------------------------------

Table 1-4 Ground load bearing information



CAUTION: The ground load

bearing information given herein is for reference only, and does not consider the optional devices of the machine. Before using the machine, always verify that the ground of the working area is safe and strong enough to support the machine.

Tire specification:

Model	Drive wheel load-6km/h (kg)	Maximum static load (kg)
T20J	5300	6800
T22J	5300	6800
T26J	8000	9000

Table 1-5 Tire specification





Chapter 2 Legend



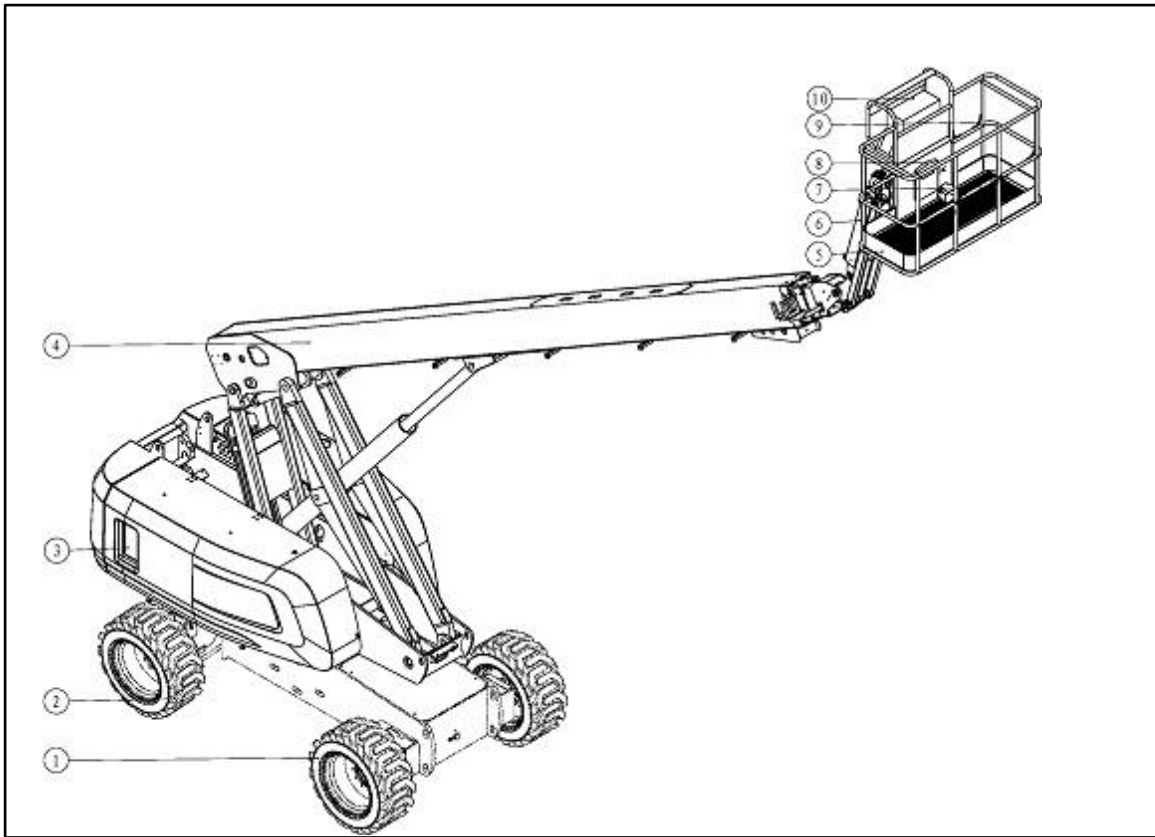

Figure 2-1 Legend of the complete machine

- 1 Non-steering wheel
- 2 Steering Wheel
- 3 Lower control box
- 4 Boom
- 5 Platform
- 6 Jib
- 7 Lifting rod
- 8 File box
- 9 Lanyard fixed point
- 10 Upper control box





Chapter 3 Decals





Operation Manual of Telescopic Boom Mobile Elevating Work Platform

T20J/T22J/T26J Decals

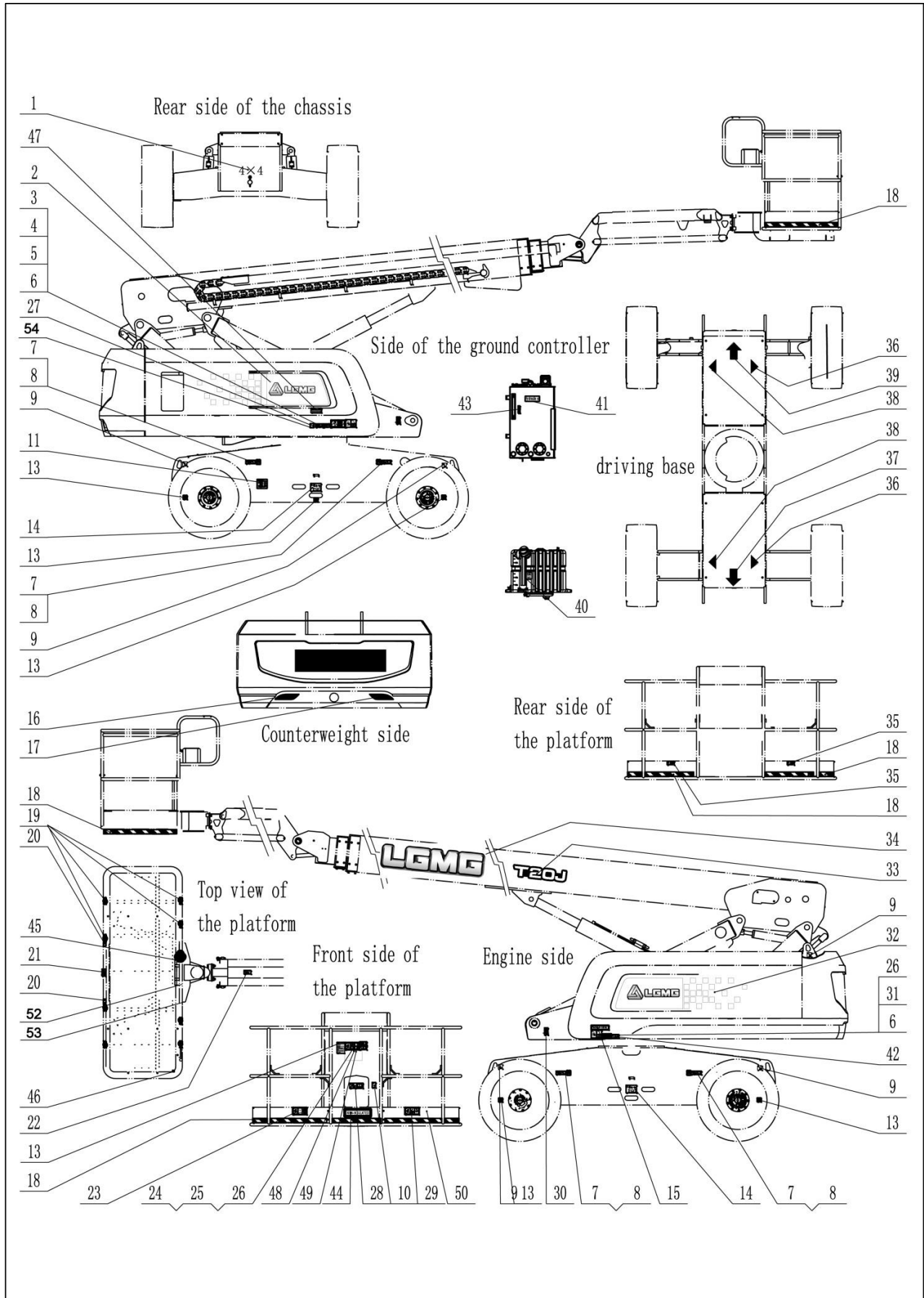

Figure 3-1 Positions of labels



Operation Manual of Telescopic Boom Mobile Elevating Work Platform

1-2534000056	2-2534000194/1521	3-2534000026	4-2534000047	5-2534000004
4 × 4				
6-2534000048	7-2534000045	8-2534000246/1752	9-2534000027	10-2534000038
11-2534004111/3	12-2534000145	13-2831990027	14-2534002019	15-2534001576
				MADE IN CHINA
16-2534000196	17-2534000197	18-2534000024	19-2534000017	20-2534000248
21-2534000036	22-2534000042	23-2534000037	24-2534000040	25-2534000039
26-2534000247	27-2534000276	28-2534000119	29-2534001579	30-2534000043
	CE			
31-2534000011	32-2534000195/1522	33-2534000509/10/1810	34-2534001775	35-2534000041
		T20J T26J T22J		



Operation Manual of Telescopic Boom Mobile Elevating Work Platform

36-2534000050



37-2534000052

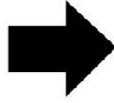

38-2534000051



39-2534000053

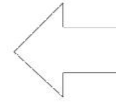

40-2534000177



41-2534001995



42-2534000786



43-2534002027



44-2534000724



45-2534001743



46-2534001809



47-2534002026



48-2534002550



49-2534002556/7/8

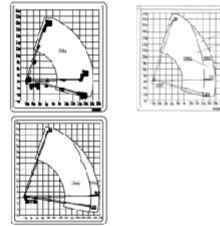

50-2534001502/1129

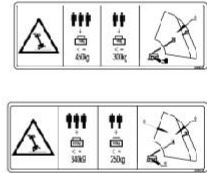

51-2534003337

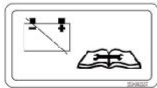

52-2534003641



53-2534003478



54-2534004014





**Operation Manual of Telescopic Boom
Mobile Elevating Work Platform**

Code	Number	Name	Code	Number	Name
1	2534000056	Decal-Driving form	28	2534000119	Decal-Reading instructions
2	2534000194 2534001521	Decal-Group LOGO-left	29	2534001579	Decal-Rated load of platform
3	2534000026	Decal-Reading instructions	30	2534000043	Decal-Anti-crush hazard
4	2534000047	Warning sign for fire prohibition	31	2534000011	Decal-In-box maintenance
5	2534000004	Warning sign for explosion and burns	32	2534000195 2534001522	Group LOGO
6	2534000048	Decal-Electric shock hazard	33	2534000509 2534001810 2534000510	Model
7	2534000045	Decal-Tire description	34	2534001775	Decal-Group LOGO
8	2534000246 2534001752	Decal-Wheel load	35	2534000041	Decal-Warning for stay away from machine
9	2534000027	Decal-Lifting	36	2534000050	Decal-Right-turn arrow - yellow
10	2534000038	Decal-Rated voltage	37	2534000052	Backward arrow sign - yellow
11	2534004111 2534004113	Decal-Machine nameplate	38	2534000051	Decal-Left-turn arrow - blue
12	2534000145	Decal-Warning	39	2534000053	Decal-Forward arrow - blue
13	2831990027	Decal-Hanger	40	2534000177	Decal-Fuel tank
14	2534002019	Decal-Lanyard fixed point	41	2534001995	Decal-Hydraulic oil box
15	2534001576	Decal-original	42	2534000786	Decal-107dB
16	2534000196	Decal-Reflective sticker	43	2534002027	Decal-Hydraulic oil level
17	2534000197	Decal-Reflective sticker	44	2534000724	Decal-NON-insulated
18	2534000024	Decal-Warning line	45	2534001743	Decal-ground connection
19	2534000017	Sign for lanyard fixed point	46	2534001809	Decal-Anti-stickers
20	2534000248	Decal-Anti-scratch sticker	47	2534002026	Decal-Instruction of power switch
21	2534000036	Caution sign for lifting and lowering the middle guardrail	48	2534002550	Decal-Slop rating
22	2534000042	Decal-Caution of falling	49	2534002556/7 /8	Decal-Range of motion
23	2534000037	Decal-Maximum manual force	50	2534001502 2534001129	Decal-double load
24	2534000040	Decal-Caution of tipping up and down the slope	51	2534003337	Decal-Power supply switch
25	2534000039	Decal-Caution of tilting	52	2534003641	Decal-Hand-hold position
26	2534000247	Decal-Electric shock hazard	53	2534003478	Decal-Risk of pinching hand
27	2534000276	Decal-CE	54	2534004014	Decal-UKCA

Table 3-1 Codes and names of Decals



Chapter 4 Machine Specifications





**Operation Manual of Telescopic Boom
Mobile Elevating Work Platform**

T20J (T0020JNDCH21) machine Specifications

4.1 Machine Performance Specifications

Item	Parameter	Item	Parameter
Rated load (kg)	250	One rotation of turntable (Stowed position) (S)	78-86
	2 People	One rotation of turntable (Raised or extended) (S)	125-165
Maximum working height (m)	21.7	Main Boom ascent (S)	60-70
Maximum platform height (m)	19.7	Main Boom descent (S)	60-70
Maximum horizontal extension (m)	17.2	Boom extension (S)	58-66
Driving Speed (Stowed) (km/h)	4.8±0.25	Boom retraction (S)	53-62
Driving Speed (Raised or extended state) (km/h)	0.8±0.05	Jib boom lift (S)	40-50
Machine climbing speed (retracted state) (km/h)	1.2≤v≤1.5	Jib boom descent (S)	20-35
Machine climbing speed (lifting state) (km/h)	0.3≤v≤0.8	Platform rotation (S)	13-26
Minimum turning radius (inner wheel) (m)	2.5	Maximum tilt angle allowed	4.5°
Minimum turning radius (outer wheel) (m)	5.5	Machine weight (kg)	11400
Theoretical gradeability	45%	Maximum allowable wind speed (m/s)	12.5
Maximum braking distance (no-load, stowed) (m)	1≤S≤1.5	Maximum manual force (N)	400
Turntable rotate angle (°)	360	Machine tail swing (mm)	1248
Secondary boom raise angle (°)	/	Jib boom raise angle (°)	130
Jib boom rotate angle (°)	/	Platform rotate angle (°)	180

4.2 Main Dimensions

Item	Parameter	Item	Parameter
Machine length (mm)	9470	Tread (mm)	2130
Machine width (mm)	2495	Wheelbase (front/rear) (mm)	2510
Machine height (mm)	2770	Ground clearance (retracted state) (mm)	395
Work platform size (length × width) (mm)	2440×900	Tire specifications (Diameter × width) (mm)	940×350

4.3 Electrical System

Item		Parameter/Content
Battery	Model	6-QW-120B
	Output voltage (V)	12
	Capacity (AH)	120(20 hours)
Control system	Voltage (V)	12

4.4 Hydraulic System

Item		Parameter/Content
Driving system	Type	Closed system



Operation Manual of Telescopic Boom Mobile Elevating Work Platform

		Working pressure (Mpa)	28
		Displacement of pump(ml/r)	46
Function system	Type		Open system
	Displacement of pump(ml/r)		28
	Lifting system(Mpa)	Working pressure (Mpa)	23
	Rotary system	Working pressure (Mpa)	23
	Steering system	Working pressure (Mpa)	23

4.5 Drive System

Item		Parameter/Content
Driving reducer	Output torque (N*m)	3390
Rotary reducer	Output torque (N*m)	1690

4.6 Engine System

Item	Parameter	Item	Parameter
Model	D2.9L4	Rated revolving speed (r/min)	2600
Displacement (L)	2.925	Maximum torque (N*m) revolving speed (r/min)	147/1600
Rated power (kW)	36.4	Emission standard	EU Stage V



CAUTION: Select corresponding brand of fuel oil according to the local working environment temperature, and refer to the Deutz D2.9L4 Engine User Manual for fuel recommendations and technical specifications.

4.7 Fueling/Grease Capacity

Item	Condition	Oil viscosity brand	Capacity	Remarks
Hydraulic oil(L)	/	Rando MV32	180	chevron
Driving reducer oil (×4) (L)	30° C<The lowest temperature	85W/140	0.68×4	API GL-5
	-10° C<The lowest temperature <30° C	85W/90		
Rotary reducer oil(L)	-30° C<The lowest temperature <-10° C	80W/90		
	The lowest temperature<-30° C	75W		
Engine oil (L)	Working temperature:-20°C~40°C	15W-40	8.5	API CH-4
	Working temperature:-25°C~30°C	10W-30		
	Working temperature:-30°C~30°C	5W-30		
	Working temperature:-35°C~20°C	0W-20		
Antifreeze(L)	/	50% LLC/50% clean soft water	7.7	/



Operation Manual of Telescopic Boom Mobile Elevating Work Platform

Diesel(L)	Ambient temperature $\geq 4^{\circ}\text{C}$	0 #Diesel	100	EN590 ULSD
	Ambient temperature $\geq -5^{\circ}\text{C}$	-10 #Diesel		
	Ambient temperature $\geq -14^{\circ}\text{C}$	-20 #Diesel		
	Ambient temperature $\geq -29^{\circ}\text{C}$	-35 #Diesel		
The inner track of gyration support	/	Lithium base grease 2#	Moderate	/
The surface of the gear	/	Lithium base grease 2#	Moderate	/

4.8 Scope of Work

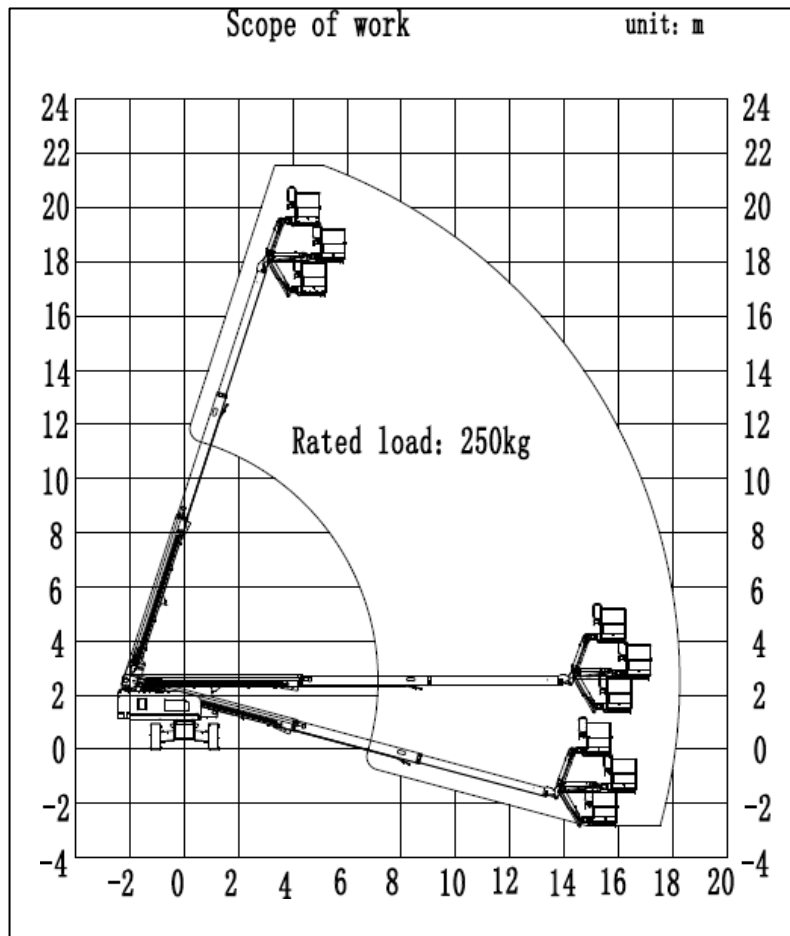

Figure 4-1 Scope of work



T20J (T0020JNDCH20) machine Specifications

4.1 Machine Performance Specifications

Item	Parameter	Item	Parameter
Rated load (kg)	250	One rotation of turntable (Stowed position) (S)	78-86
	2 People	One rotation of turntable (Raised or extended) (S)	125-165
Maximum working height (m)	21.7	Main Boom ascent (S)	60-70
Maximum platform height (m)	19.7	Main Boom descent (S)	60-70
Maximum horizontal extension (m)	17.2	Boom extension (S)	58-66
Driving Speed (Stowed) (km/h)	4.8±0.25	Boom retraction (S)	53-62
Driving Speed (Raised or extended state) (km/h)	0.8±0.05	Jib boom lift (S)	40-50
Machine climbing speed (retracted state) (km/h)	1.2≤v≤1.5	Jib boom descent (S)	20-35
Machine climbing speed (lifting state) (km/h)	0.3≤v≤0.8	Platform rotation (S)	13-26
Minimum turning radius (inner wheel) (m)	2.5	Maximum tilt angle allowed	4.5°
Minimum turning radius (outer wheel) (m)	5.5	Machine weight (kg)	11400
Theoretical gradeability	45%	Maximum allowable wind speed (m/s)	12.5
Maximum braking distance (no-load, stowed) (m)	1≤S≤1.5	Maximum manual force (N)	400
Turntable rotate angle (°)	360	Machine tail swing (mm)	1248
Secondary boom raise angle (°)	/	Jib boom raise angle (°)	130
Jib boom rotate angle (°)	/	Platform rotate angle (°)	180

4.2 Main Dimensions

Item	Parameter	Item	Parameter
Machine length (mm)	9470	Tread (mm)	2130
Machine width (mm)	2495	Wheelbase (front/rear) (mm)	2510
Machine height (mm)	2770	Ground clearance (retracted state) (mm)	395
Work platform size (length × width) (mm)	2440×900	Tire specifications (Diameter × width) (mm)	940×350

4.3 Electrical System

Item		Parameter/Content
Battery	Model	6-QW-120B
	Output voltage (V)	12
	Capacity (AH)	120(20 hours)
Control system	Voltage (V)	12

4.4 Hydraulic System



Operation Manual of Telescopic Boom Mobile Elevating Work Platform

Item		Parameter/Content	
Driving system	Type	Closed system	
	Working pressure (Mpa)	28	
	Displacement of pump(ml/r)	46	
Function system	Type	Open system	
	Displacement of pump(ml/r)		23
	Lifting system(Mpa)	Working pressure (Mpa)	22
	Rotary system	Working pressure (Mpa)	22
	Steering system	Working pressure (Mpa)	15

4.5 Drive System

Item		Parameter/Content
Driving reducer	Output torque (N*m)	3390
Rotary reducer	Output torque (N*m)	1690

4.6 Engine System

Item	Parameter	Item	Parameter
Model	D2.9L4	Rated revolving speed (r/min)	2600
Displacement (L)	2.925	Maximum torque (N*m) revolving speed (r/min)	147/1600
Rated power (kW)	36.4	Emission standard	EU Stage V



CAUTION: Select corresponding brand of fuel oil according to the local working environment temperature, and refer to the Deutz D2.9L4 Engine User Manual for fuel recommendations and technical specifications.

4.7 Fueling/Grease Capacity

Item	Condition	Oil viscosity brand	Capacity	Remarks
Hydraulic oil(L)	/	Rando MV32	180	Chevron
Driving reducer oil (×4) (L)	30° C<The lowest temperature	85W/140	0.68×4	API GL-5
	-10° C<The lowest temperature <30° C	85W/90		
Rotary reducer oil(L)	-30° C<The lowest temperature <-10° C	80W/90	1.3	
	The lowest temperature<-30° C	75W		
Engine oil (L)	Working temperature:-20℃~40℃	15W-40	8.5	API CH-4
	Working temperature:-25℃~30℃	10W-30		
	Working temperature:-30℃~30℃	5W-30		
	Working temperature:-35℃~20℃	0W-20		
Antifreeze(L)	/	50% LLC/50%	7.7	/



Operation Manual of Telescopic Boom Mobile Elevating Work Platform

		clean soft water		
Diesel(L)	Ambient temperature $\geq 4^{\circ}\text{C}$	0 #Diesel	100	EN590 ULSD
	Ambient temperature $\geq -5^{\circ}\text{C}$	-10 #Diesel		
	Ambient temperature $\geq -14^{\circ}\text{C}$	-20 #Diesel		
	Ambient temperature $\geq -29^{\circ}\text{C}$	-35 #Diesel		
The inner track of gyration support	/	Lithium base grease 2#	Moderate	/
The surface of the gear	/	Lithium base grease 2#	Moderate	/

4.8 Scope of Work

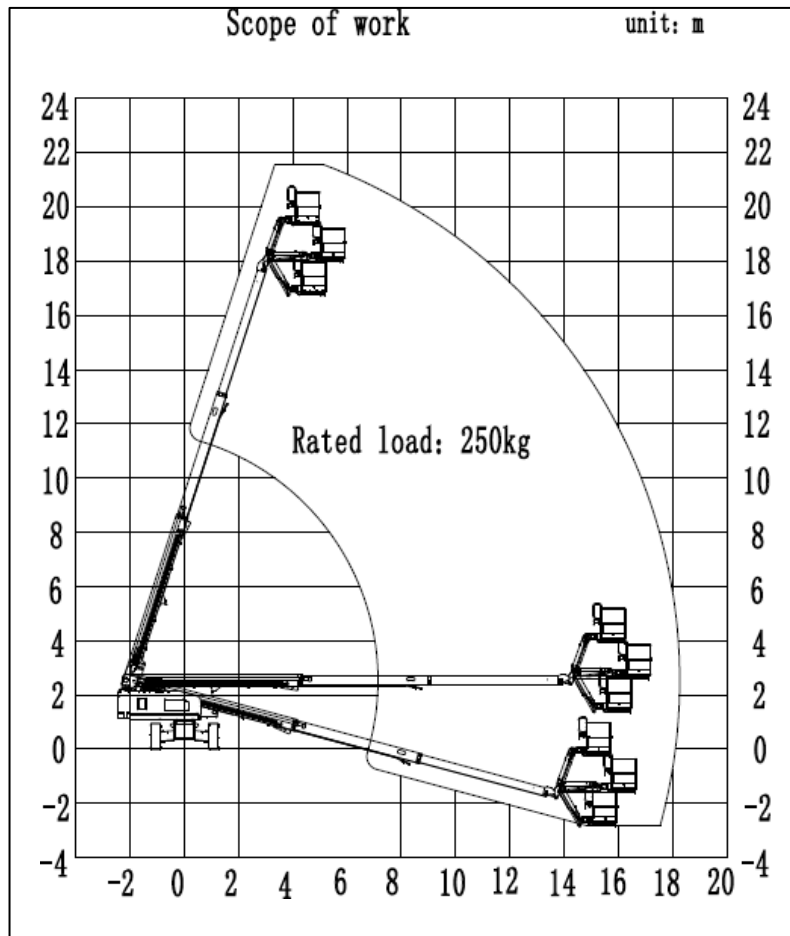

Figure 4-2 Scope of work



T20J (T0020JNKCH21) machine Specifications

4.1 Machine Performance Specifications

Item	Parameter	Item	Parameter
Rated load (kg)	250	One rotation of turntable (Stowed position) (S)	78-86
	2 People	One rotation of turntable (Raised or extended) (S)	125-165
Maximum working height (m)	21.7	Main Boom ascent (S)	60-70
Maximum platform height (m)	19.7	Main Boom descent (S)	60-70
Maximum horizontal extension (m)	17.2	Boom extension (S)	58-66
Driving Speed (Stowed) (km/h)	4.8±0.25	Boom retraction (S)	53-62
Driving Speed (Raised or extended state) (km/h)	0.8±0.05	Jib boom lift (S)	40-50
Machine climbing speed (retracted state) (km/h)	1.2≤v≤1.5	Jib boom descent (S)	20-35
Machine climbing speed (lifting state) (km/h)	0.3≤v≤0.8	Platform rotation (S)	13-26
Minimum turning radius (inner wheel) (m)	2.5	Maximum tilt angle allowed	4.5°
Minimum turning radius (outer wheel) (m)	5.5	Machine weight (kg)	11400
Theoretical gradeability	45%	Maximum allowable wind speed (m/s)	12.5
Maximum braking distance (no-load, stowed) (m)	1≤S≤1.5	Maximum manual force (N)	400
Turntable rotate angle (°)	360	Machine tail swing (mm)	1248
Secondary boom raise angle (°)	/	Jib boom raise angle (°)	130
Jib boom rotate angle (°)	/	Platform rotate angle (°)	180

4.2 Main Dimensions

Item	Parameter	Item	Parameter
Machine length (mm)	9470	Tread (mm)	2130
Machine width (mm)	2495	Wheelbase (front/rear) (mm)	2510
Machine height (mm)	2770	Ground clearance (retracted state) (mm)	395
Work platform size (length × width) (mm)	2440×900	Tire specifications (Diameter × width) (mm)	940×350

4.3 Electrical System

Item		Parameter/Content
Battery	Model	6-QW-120B
	Output voltage (V)	12
	Capacity (AH)	120(20 hours)
Control system	Voltage (V)	12

4.4 Hydraulic System

Item		Parameter/Content
Driving system	Type	Closed system



Operation Manual of Telescopic Boom Mobile Elevating Work Platform

		Working pressure (Mpa)	28
		Displacement of pump(ml/r)	46
Function system	Type		Open system
	Displacement of pump(ml/r)		23
	Lifting system(Mpa)	Working pressure (Mpa)	22
	Rotary system	Working pressure (Mpa)	22
	Steering system	Working pressure (Mpa)	15

4.5 Drive System

Item		Parameter/Content
Driving reducer	Output torque (N*m)	3390
Rotary reducer	Output torque (N*m)	1690

4.6 Engine System

Item	Parameter	Item	Parameter
Model	V2403-CR-EW02	Rated revolving speed (r/min)	2600
Displacement (L)	2.4	Maximum torque (N*m) revolving speed (r/min)	157.4/1600
Rated power (kW)	36	Emission standard	EU Stage V



CAUTION: Select corresponding brand of fuel oil according to the local working environment temperature, and refer to the Kubota V2403-CR-E5 Engine User Manual for fuel recommendations and technical specifications.

4.7 Fueling/Grease Capacity

Item	Condition	Oil viscosity brand	Capacity	Remarks
Hydraulic oil(L)	/	Rando MV32	180	Chevron
Driving reducer oil (×4) (L)	30° C<The lowest temperature	85W/140	0.68×4	API GL-5
Rotary reducer oil(L)	-10° C<The lowest temperature <30° C	85W/90		
	-30° C<The lowest temperature <-10° C	80W/90		
Engine oil (L)	The lowest temperature <-30° C	75W	1.3	API CJ-4
	Working temperature:-20°C~40°C	15W-40	9.5	
	Working temperature:-25°C~30°C	10W-30		
	Working temperature:-30°C~30°C	5W-30		
Working temperature:-35°C~20°C	0W-20			
Antifreeze(L)	/	50% LLC/50% clean soft water	7.7	/
Diesel(L)	Ambient temperature≥4°C	0 #Diesel	100	



Operation Manual of Telescopic Boom Mobile Elevating Work Platform

	Ambient temperature $\geq -5^{\circ}\text{C}$	-10 #Diesel		EN590 ULSD
	Ambient temperature $\geq -14^{\circ}\text{C}$	-20 #Diesel		
	Ambient temperature $\geq -29^{\circ}\text{C}$	-35 #Diesel		
The inner track of gyration support	/	Lithium base grease 2#	Moderate	/
The surface of the gear	/	Lithium base grease 2#	Moderate	/

4.8 Scope of Work

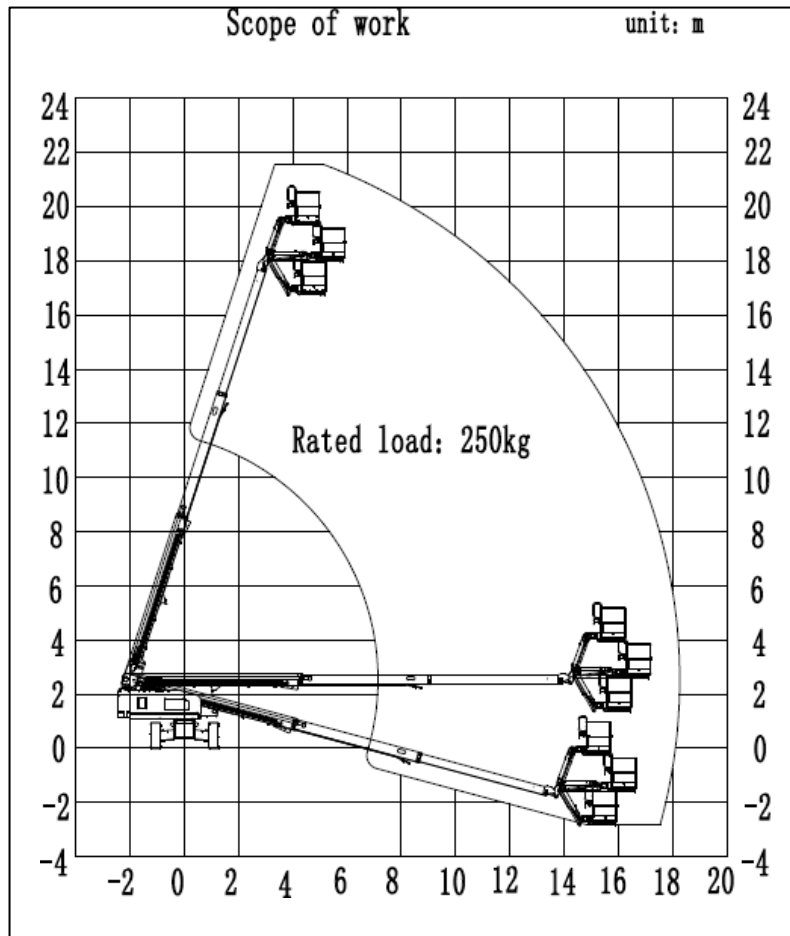

Figure 4-3 Scope of work



**Operation Manual of Telescopic Boom
Mobile Elevating Work Platform**

T20J (T2017J0WND3CH2000) machine Specifications

4.1 Machine Performance Specifications

Item	Parameter	Item	Parameter
Rated load (kg)	250	One rotation of turntable (Stowed position) (S)	78-86
	2 People	One rotation of turntable (Raised or extended) (S)	125-165
Maximum working height (m)	21.7	Main Boom ascent (S)	60-70
Maximum platform height (m)	19.7	Main Boom descent (S)	60-70
Maximum horizontal extension (m)	17.2	Boom extension (S)	58-66
Driving Speed (Stowed) (km/h)	4.8±0.25	Boom retraction (S)	53-62
Driving Speed (Raised or extended state) (km/h)	0.8±0.05	Jib boom lift (S)	40-50
Machine climbing speed (retracted state) (km/h)	1.2≤v≤1.5	Jib boom descent (S)	20-35
Machine climbing speed (lifting state) (km/h)	0.3≤v≤0.8	Platform rotation (S)	13-26
Minimum turning radius (inner wheel) (m)	2.5	Maximum tilt angle allowed	4.5°
Minimum turning radius (outer wheel) (m)	5.5	Machine weight (kg)	11400
Theoretical gradeability	45%	Maximum allowable wind speed (m/s)	12.5
Maximum braking distance (no-load, stowed) (m)	1≤S≤1.5	Maximum manual force (N)	400
Turntable rotate angle (°)	360	Machine tail swing (mm)	1248
Secondary boom raise angle (°)	/	Jib boom raise angle (°)	130
Jib boom rotate angle (°)	/	Platform rotate angle (°)	180

4.2 Main Dimensions

Item	Parameter	Item	Parameter
Machine length (mm)	9470	Tread (mm)	2130
Machine width (mm)	2495	Wheelbase (front/rear) (mm)	2510
Machine height (mm)	2770	Ground clearance (retracted state) (mm)	395
Work platform size (length × width) (mm)	2440×900	Tire specifications (Diameter × width) (mm)	940×350

4.3 Electrical System

Item		Parameter/Content
Battery	Model	6-QW-120B
	Output voltage (V)	12
	Capacity (AH)	120(20 hours)
Control system	Voltage (V)	12

4.4 Hydraulic System

Item		Parameter/Content
Driving system	Type	Closed system



Operation Manual of Telescopic Boom Mobile Elevating Work Platform

		Working pressure (Mpa)	28
		Displacement of pump(ml/r)	46
Function system	Type		Open system
	Displacement of pump(ml/r)		23
	Lifting system(Mpa)	Working pressure (Mpa)	22
	Rotary system	Working pressure (Mpa)	22
	Steering system	Working pressure (Mpa)	15

4.5 Drive System

Item		Parameter/Content
Driving reducer	Output torque (N*m)	3390
Rotary reducer	Output torque (N*m)	1690

4.6 Engine System

Item	Parameter	Item	Parameter
Model	D2011L03i	Rated revolving speed (r/min)	2800
Displacement (L)	2.331	Maximum torque (N*m) revolving speed (r/min)	137/1700
Rated power (kW)	36.3	Emission standard	EU Stage III



CAUTION: Select corresponding brand of fuel oil according to the local working environment temperature, and refer to the Deutz D2011L03i Engine User Manual for fuel recommendations and technical specifications.

4.7 Fueling/Grease Capacity

Item	Condition	Oil viscosity brand	Capacity	Remarks
Hydraulic oil(L)	/	Rando MV32	180	Chevron
Driving reducer oil (×4) (L)	30° C<The lowest temperature	85W/140	0.68×4	API GL-5
	-10° C<The lowest temperature <30° C	85W/90		
Rotary reducer oil(L)	-30° C<The lowest temperature <-10° C	80W/90		
	The lowest temperature<-30° C	75W	1.3	
Engine oil (L)	Working temperature:-20℃~40℃	15W-40	8	API CH-4
	Working temperature:-25℃~30℃	10W-30		
	Working temperature:-30℃~30℃	5W-30		
	Working temperature:-35℃~20℃	0W-20		
Antifreeze(L)	/	/	/	/
Diesel(L)	Ambient temperature≥4℃	0 #Diesel	100	



Operation Manual of Telescopic Boom Mobile Elevating Work Platform

	Ambient temperature $\geq -5^{\circ}\text{C}$	-10 #Diesel		EN590 ULSD
	Ambient temperature $\geq -14^{\circ}\text{C}$	-20 #Diesel		
	Ambient temperature $\geq -29^{\circ}\text{C}$	-35 #Diesel		
The inner track of gyration support	/	Lithium base grease 2#	Moderate	/
The surface of the gear	/	Lithium base grease 2#	Moderate	/

4.8 Scope of Work

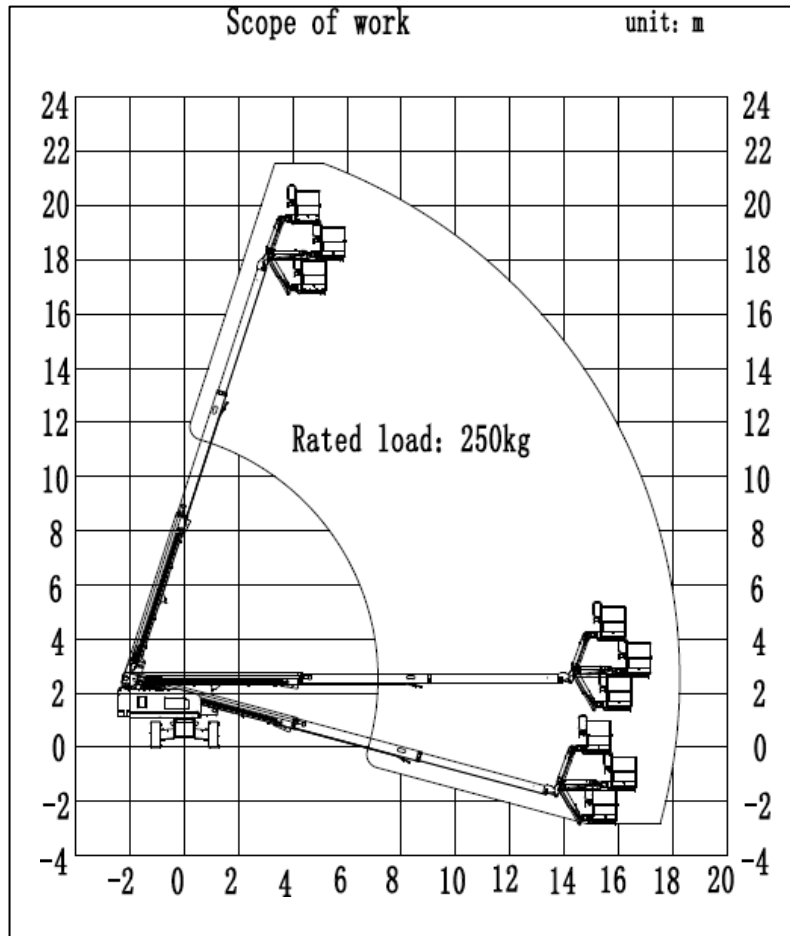

Figure 4-4 Scope of work



**Operation Manual of Telescopic Boom
Mobile Elevating Work Platform**

T22J (T2218J0WND5CH2000) machine Specifications

4.1 Machine Performance Specifications

Item	Parameter	Item	Parameter
Rated load (kg)	300	One rotation of turntable (Stowed) (S)	78-86
	2 people		
Restricted load (kg)	450	One rotation of turntable (Raised or extended) (S)	125-165
	3 people		
Maximum working height (m)	23.8	Main Boom ascent (S)	60-70
Maximum platform height (m)	21.8	Main Boom descent (S)	60-70
Maximum horizontal extension (m)	17.5	Boom extension (S)	65-75
Driving Speed (Stowed) (km/h)	4.8±0.25	Boom retraction (S)	60-70
Driving Speed (lifting state) (km/h)	0.8±0.05	Jib lift (S)	40-50
Machine climbing speed (retracted state) (km/h)	1.2≤v≤1.5	Jib descent (S)	20-35
Machine climbing speed (lifting state) (km/h)	0.3≤v≤0.8	Platform rotation (S)	13-26
Minimum turning radius (inner wheel) (m)	2.5	Maximum tilt angle allowed	4.5°
Minimum turning radius (outer wheel) (m)	5.5	Machine weight (kg)	12300
Theoretical gradeability	45%	Maximum allowable wind speed(m/s)	12.5
Maximum braking distance (no-load, stowed) (m)	1≤S≤1.5	Maximum manual force (N)	400
Turntable rotate angle (°)	360	Machine tail swing (mm)	1399
Secondary boom raise angle (°)	/	Jib boom raise angle (°)	130
Jib boom rotate angle (°)	/	Platform rotate angle (°)	180

4.2 Main Dimensions

Item	Parameter	Item	Parameter
Machine length (mm)	10600	Tread (mm)	2130
Machine width (mm)	2490	Wheelbase (front/rear) (mm)	2510
Machine height (mm)	2790	Ground clearance (retracted state) (mm)	395
Work platform size (length × width) (mm)	2440×900	Tire specifications (Diameter × width) (mm)	940×350

4.3 Electrical System

Item		Parameter/Content
Battery	Model	6-QW-120B
	Output voltage (V)	12
	Capacity (AH)	120(20 hours)
Control system	Voltage (V)	12

4.4 Hydraulic System

Item		Parameter/Content
Driving system	Type	Closed system



Operation Manual of Telescopic Boom Mobile Elevating Work Platform

		Working pressure (Mpa)	28
		Displacement of pump(ml/r)	46
Function system	Type		Open system
	Displacement of pump(ml/r)		28
	Lifting system(Mpa)	Working pressure (Mpa)	23
	Rotary system	Working pressure (Mpa)	23
	Steering system	Working pressure (Mpa)	23

4.5 Drive System

Item		Parameter/Content
Driving reducer	Output torque (N*m)	3390
Rotary reducer	Output torque (N*m)	1690

4.6 Engine System

Item	Parameter	Item	Parameter
Model	D2.9L4	Rated revolving speed (r/min)	2600
Displacement (L)	2.925	Maximum torque (N*m) revolving speed (r/min)	147/1600
Rated power (kW)	36.4	Emission standard	EU Stage V



CAUTION: Select corresponding brand of fuel oil according to the local working environment temperature, and refer to the Deutz D2.9L4 Engine User Manual for fuel recommendations and technical specifications.

4.7 Fueling/Grease Capacity

Item	Condition	Oil viscosity brand	Capacity	Remarks
Hydraulic oil(L)	/	Rando MV32	180	Chevron
Driving reducer oil (×4) (L)	30° C < The lowest temperature	85W/140	0.68×4	API GL-5
	-10° C < The lowest temperature < 30° C	85W/90		
Rotary reducer oil(L)	-30° C < The lowest temperature < -10° C	80W/90		
	The lowest temperature < -30° C	75W		
Engine oil(L)	Working temperature: -20°C ~ 40°C	15W-40	8.5	API CH-4
	Working temperature: -25°C ~ 30°C	10W-30		
	Working temperature: -30°C ~ 30°C	5W-30		
	Working temperature: -35°C ~ 20°C	0W-20		
Antifreeze (L)	/	50% LLC/50% clean soft water	7.7	/
Diesel (L)	Ambient temperature ≥ 4°C	0 #Diesel	100	



Operation Manual of Telescopic Boom Mobile Elevating Work Platform

	Ambient temperature $\geq -5^{\circ}\text{C}$	-10 #Diesel		EN590 ULSD
	Ambient temperature $\geq -14^{\circ}\text{C}$	-20 #Diesel		
	Ambient temperature $\geq -29^{\circ}\text{C}$	-35 #Diesel		
The inner track of gyration support	/	Lithium base grease 2#	Moderate	/
The surface of the gear	/	Lithium base grease 2#	Moderate	/

4.8 Scope of Work

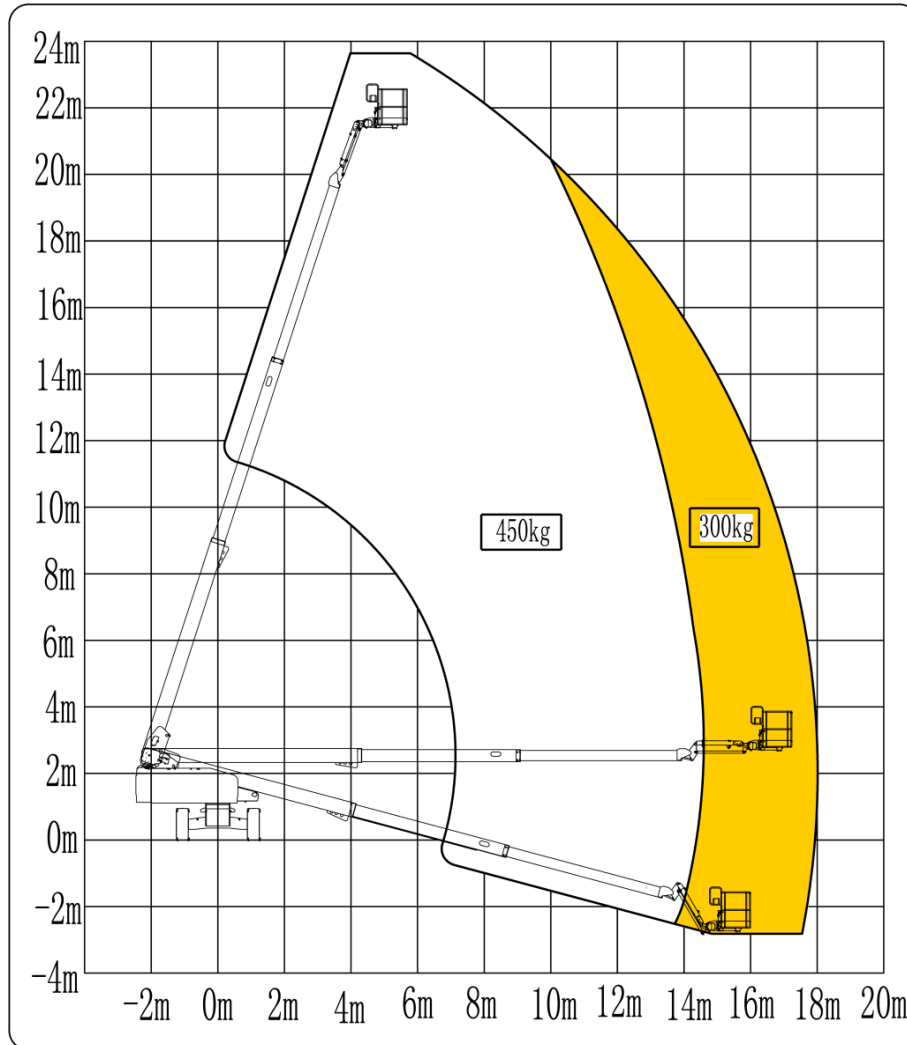

Figure 4-5 Scope of work

sequence of operation:

When operating with a ground controller: The machine motion range is automatically controlled according to the load on the platform.

When the platform load is less than 300kg, T22J motion range is not restricted.

When the platform load is greater than 300kg and less than 450kg, T22J motion range is restricted.

When operating with the platform controller: The machine motion range is controlled by the load selection button switch of the platform controller.



Operation Manual of Telescopic Boom Mobile Elevating Work Platform

Turn the dial button switch to 300kg: The rated load of the machine is 300kg, and the motion range of T22J is not restricted.

Turn the dial button switch to 450kg: The restricted load of the machine is 450kg, and the motion range of T22J is restricted.



**Operation Manual of Telescopic Boom
Mobile Elevating Work Platform**

T22J (T2218J0WNK5CH2000) machine Specifications

4.1 Machine Performance Specifications

Item	Parameter	Item	Parameter
Rated load (kg)	300	One rotation of turntable (Stowed) (S)	78-86
	2 people		
Restricted load (kg)	450	One rotation of turntable (Raised or extended) (S)	125-165
	3 people		
Maximum working height (m)	23.8	Main Boom ascent (S)	60-70
Maximum platform height (m)	21.8	Main Boom descent (S)	60-70
Maximum horizontal extension (m)	17.5	Boom extension (S)	65-75
Driving Speed (Stowed) (km/h)	4.8±0.25	Boom retraction (S)	60-70
Driving Speed (lifting state) (km/h)	0.8±0.05	Jib lift (S)	40-50
Machine climbing speed (retracted state) (km/h)	1.2≤v≤1.5	Jib descent (S)	20-35
Machine climbing speed (lifting state) (km/h)	0.3≤v≤0.8	Platform rotation (S)	13-26
Minimum turning radius (inner wheel) (m)	2.5	Maximum tilt angle allowed	4.5°
Minimum turning radius (outer wheel) (m)	5.5	Machine weight (kg)	12300
Theoretical gradeability	45%	Maximum allowable wind speed(m/s)	12.5
Maximum braking distance (no-load, stowed) (m)	1≤S≤1.5	Maximum manual force (N)	400
Turntable rotate angle (°)	360	Machine tail swing (mm)	1399
Secondary boom raise angle (°)	/	Jib boom raise angle (°)	130
Jib boom rotate angle (°)	/	Platform rotate angle (°)	180

4.2 Main Dimensions

Item	Parameter	Item	Parameter
Machine length (mm)	10600	Tread (mm)	2130
Machine width (mm)	2490	Wheelbase (front/rear) (mm)	2510
Machine height (mm)	2790	Ground clearance (retracted state) (mm)	395
Work platform size (length × width) (mm)	2440×900	Tire specifications (Diameter ×width) (mm)	940×350

4.3 Electrical System

Item		Parameter/Content
Battery	Model	6-QW-120B
	Output voltage (V)	12
	Capacity (AH)	120(20 hours)
Control system	Voltage (V)	12

4.4 Hydraulic System

Item		Parameter/Content
Driving system	Type	Closed system



Operation Manual of Telescopic Boom Mobile Elevating Work Platform

		Working pressure (Mpa)	28
		Displacement of pump(ml/r)	46
Function system	Type		Open system
	Displacement of pump(ml/r)		28
	Lifting system(Mpa)	Working pressure (Mpa)	23
	Rotary system	Working pressure (Mpa)	23
	Steering system	Working pressure (Mpa)	23

4.5 Drive System

Item		Parameter/Content
Driving reducer	Output torque (N*m)	3390
Rotary reducer	Output torque (N*m)	1690

4.6 Engine System

Item	Parameter	Item	Parameter
Model	V2403-CR-E5	Rated revolving speed (r/min)	2600
Displacement (L)	2.4	Maximum torque (N*m) revolving speed (r/min)	159.8/1600
Rated power (kW)	36	Emission standard	EU Stage V



CAUTION: Select corresponding brand of fuel oil according to the local working environment temperature, and refer to the Kubota V2403-CR-E5 Engine User Manual for fuel recommendations and technical specifications.

4.7 Fueling/Grease Capacity

Item	Condition	Oil viscosity brand	Capacity	Remarks
Hydraulic oil(L)	/	Rando MV32	180	Chevron
Driving reducer oil (×4) (L)	30° C<The lowest temperature	85W/140	0.68×4	API GL-5
Rotary reducer oil(L)	-10° C<The lowest temperature <30° C	85W/90		
	-30° C<The lowest temperature <-10° C	80W/90		
Engine oil(L)	The lowest temperature<-30° C	75W	9.5	API CJ-4
	Working temperature:-20℃~40℃	15W-40		
	Working temperature:-25℃~30℃	10W-30		
	Working temperature:-30℃~30℃	5W-30		
Working temperature:-35℃~20℃	0W-20			
Antifreeze (L)	/	50% LLC/50% clean soft water	7.7	/



Operation Manual of Telescopic Boom Mobile Elevating Work Platform

Diesel (L)	Ambient temperature $\geq 4^{\circ}\text{C}$	0 #Diesel	100	EN590 ULSD
	Ambient temperature $\geq -5^{\circ}\text{C}$	-10 #Diesel		
	Ambient temperature $\geq -14^{\circ}\text{C}$	-20 Diesel		
	Ambient temperature $\geq -29^{\circ}\text{C}$	-35 Diesel		
The inner track of gyration support	/	Lithium base grease 2#	Moderate	/
The surface of the gear	/	Lithium base grease 2#	Moderate	/

4.8 Scope of Work

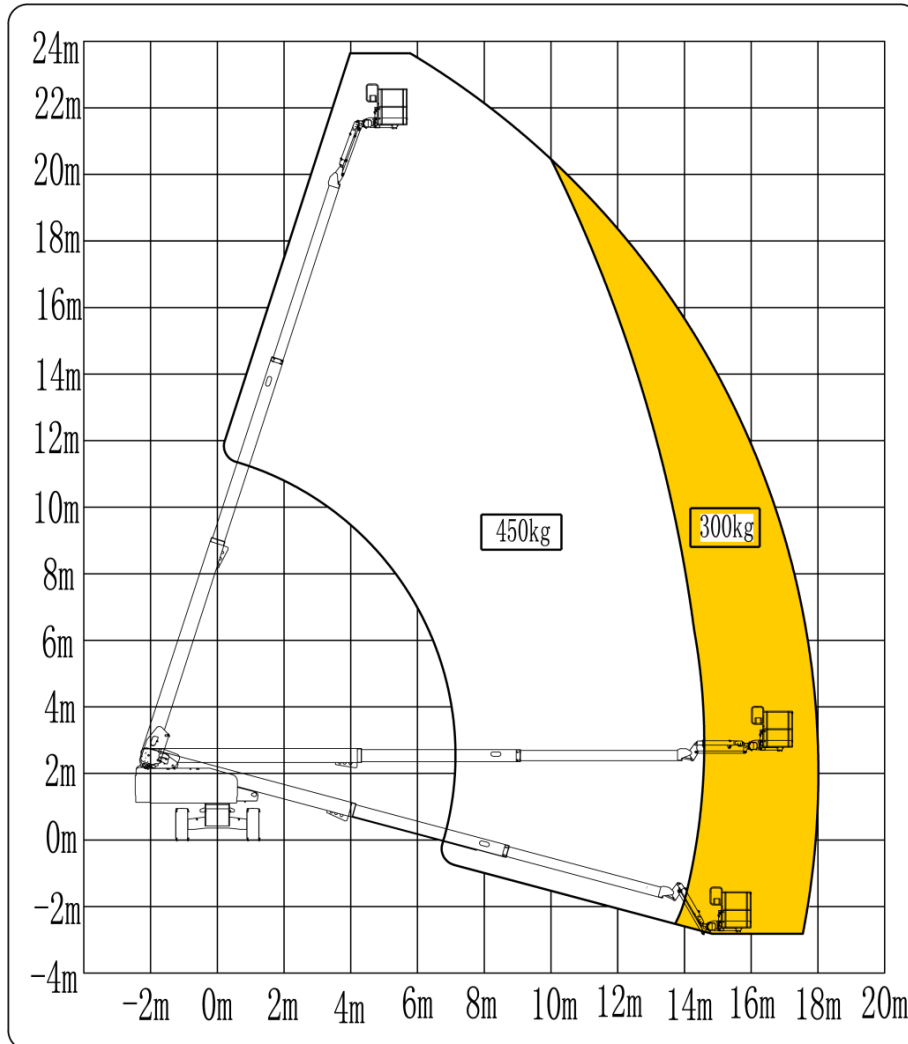

Figure 4-6 Scope of work

sequence of operation:

When operating with a ground controller: The machine motion range is automatically controlled according to the load on the platform.

When the platform load is less than 300kg, T22J motion range is not restricted.

When the platform load is greater than 300kg and less than 450kg, T22J motion range is restricted.

When operating with the platform controller: The machine motion range is controlled by the load



Operation Manual of Telescopic Boom Mobile Elevating Work Platform

selection button switch of the platform controller.

Turn the dial button switch to 300kg: The rated load of the machine is 300kg, and the motion range of T22J is not restricted.

Turn the dial button switch to 450kg: The restricted load of the machine is 450kg, and the motion range of T22J is restricted.



**Operation Manual of Telescopic Boom
Mobile Elevating Work Platform**

T26J (T2623J0WND5CH2000) machine Specifications

4.1 Machine Performance Specifications

Item	Parameter	Item	Parameter
Rated load (kg)	250	One rotation of turntable (Stowed) (S)	90-110
	2 people		
Restricted load (kg)	340	One rotation of turntable (Raised or extended) (S)	170-200
	3 people		
Maximum working height (m)	27.9	Main Boom ascent (S)	70-90
Maximum platform height (m)	25.9	Main Boom descent (S)	70-90
Maximum horizontal extension (m)	23.32	Boom extension (S)	55-73
Driving Speed (Stowed) (km/h)	4.8±0.25	Boom retraction (S)	55-73
Driving Speed (lifting state) (km/h)	0.8±0.05	Jib lift (S)	25-35
Machine climbing speed (retracted state) (km/h)	1.2≤v≤1.5	Jib descent (S)	15-25
Machine climbing speed (lifting state) (km/h)	0.3≤v≤0.8	Platform rotation (S)	13-26
Minimum turning radius (inner wheel) (m)	3.66	Maximum tilt angle allowed	4.5°
Minimum turning radius (outer wheel) (m)	6.55	Machine weight (kg)	18000
Theoretical gradeability	45%	Maximum allowable wind speed(m/s)	12.5
Maximum braking distance (no-load, stowed) (m)	1≤S≤1.5	Maximum manual force (N)	400
Turntable rotate angle (°)	360	Machine tail swing (mm)	1400
Secondary boom raise angle (°)	/	Jib boom raise angle (°)	120
Jib boom rotate angle (°)	/	Platform rotate angle (°)	180

4.2 Main Dimensions

Item	Parameter	Item	Parameter
Machine length (mm)	12600	Tread (mm)	2050
Machine width (mm)	2500	Wheelbase (front/rear) (mm)	2850
Machine height (mm)	2840	Ground clearance (retracted state) (mm)	440
Work platform size (length × width) (mm)	2440×900	Tire specifications (Diameter × width) (mm)	1035×450

4.3 Electrical System

Item		Parameter/Content
Battery	Model	6-QW-120B
	Output voltage (V)	12
	Capacity (AH)	120(20 hours)
Control system	Voltage (V)	12

4.4 Hydraulic System

Item		Parameter/Content
Driving system	Type	Closed system



Operation Manual of Telescopic Boom Mobile Elevating Work Platform

		Working pressure (Mpa)	28
		Displacement of pump(ml/r)	46
Function system	Type		Open system
	Displacement of pump(ml/r)		35
	Lifting system(Mpa)	Working pressure (Mpa)	20
	Rotary system	Working pressure (Mpa)	20
	Steering system	Working pressure (Mpa)	20

4.5 Drive System

Item		Parameter/Content
Driving reducer	Output torque (N*m)	5500
Rotary reducer	Output torque (N*m)	1690

4.6 Engine System

Item	Parameter	Item	Parameter
Model	TD2.9L4	Rated revolving speed (r/min)	2600
Displacement (L)	2.925	Maximum torque (N*m) revolving speed (r/min)	260/1800
Rated power (kW)	55.4	Emission standard	EU Stage V



CAUTION: Select corresponding brand of fuel oil according to the local working environment temperature, and refer to the Deutz TD2.9L4 Engine User Manual for fuel recommendations and technical specifications.

4.7 Fueling/Grease Capacity

Item	Condition	Oil viscosity brand	Capacity	Remarks
Hydraulic oil(L)	/	Rando MV32	180	Chevron
Driving reducer oil (×4) (L)	30° C<The lowest temperature	85W/140	1.5×4	API GL-5
	-10° C<The lowest temperature <30° C	85W/90		
Rotary reducer oil(L)	-30° C<The lowest temperature <-10° C	80W/90	1.3	
	The lowest temperature<-30° C	75W		
Engine oil(L)	Working temperature:-20°C~40°C	15W-40	8.5	API CH-4
	Working temperature:-25°C~30°C	10W-30		
	Working temperature:-30°C~30°C	5W-30		
	Working temperature:-35°C~20°C	0W-20		
Antifreeze (L)	/	50% LLC/50% clean soft water	9.3	/
Diesel (L)	Ambient temperature≥4°C	0 #Diesel	100	



Operation Manual of Telescopic Boom Mobile Elevating Work Platform

	Ambient temperature $\geq -5^{\circ}\text{C}$	-10 #Diesel		EN590 ULSD
	Ambient temperature $\geq -14^{\circ}\text{C}$	-20 Diesel		
	Ambient temperature $\geq -29^{\circ}\text{C}$	-35 Diesel		
The inner track of gyration support	/	Lithium base grease 2#	Moderate	/
The surface of the gear	/	Lithium base grease 2#	Moderate	/

4.8 Scope of Work

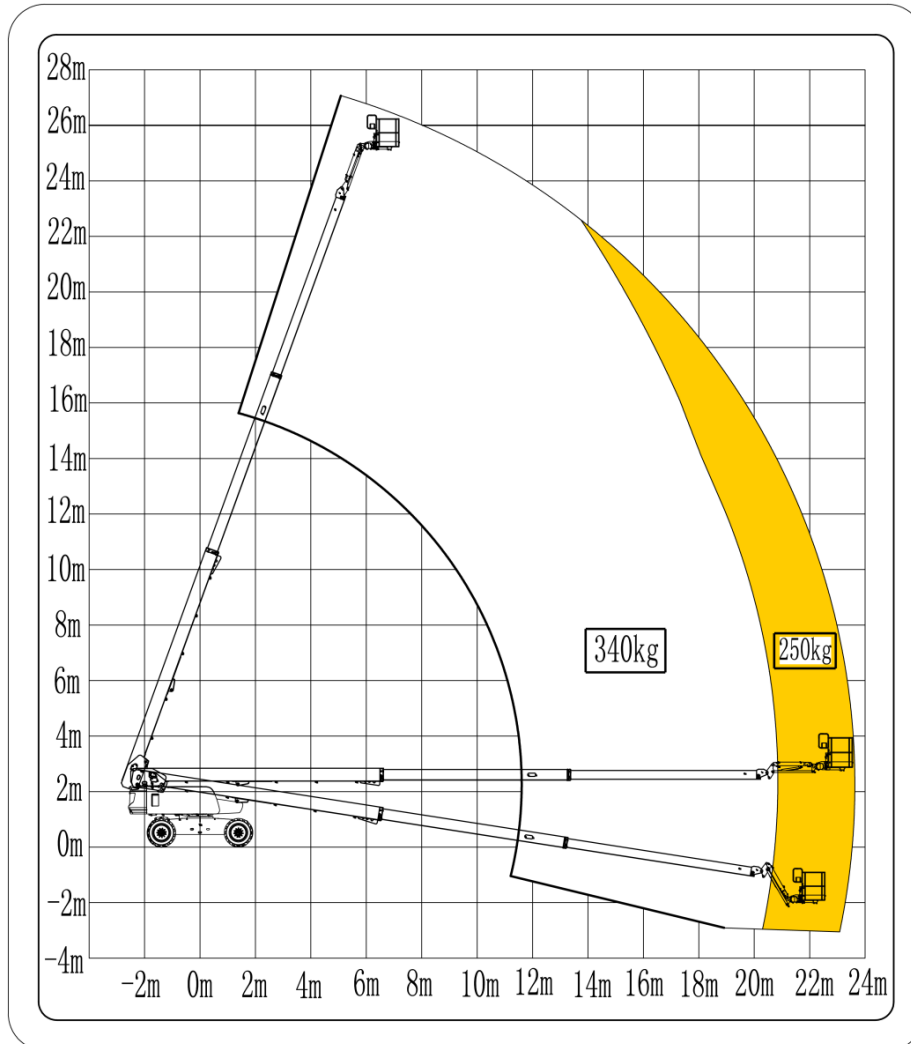

Figure 4-7 Scope of work

sequence of operation:

When operating with a ground controller: The machine motion range is automatically controlled according to the load on the platform.

When the platform load is less than 250kg, T26J motion range is not restricted.

When the platform load is greater than 250kg and less than 340kg, T26J motion range is restricted.

When operating with the platform controller: The machine motion range is controlled by the load



Operation Manual of Telescopic Boom Mobile Elevating Work Platform

selection button switch of the platform controller.

Turn the dial button switch to 250kg: The rated load of the machine is 250kg, and the motion range of T26J is not restricted.

Turn the dial button switch to 340kg: The restricted load of the machine is 340kg, and the motion range of T26J is restricted.



Chapter 5 Control Box





5.1 Lower Control Box

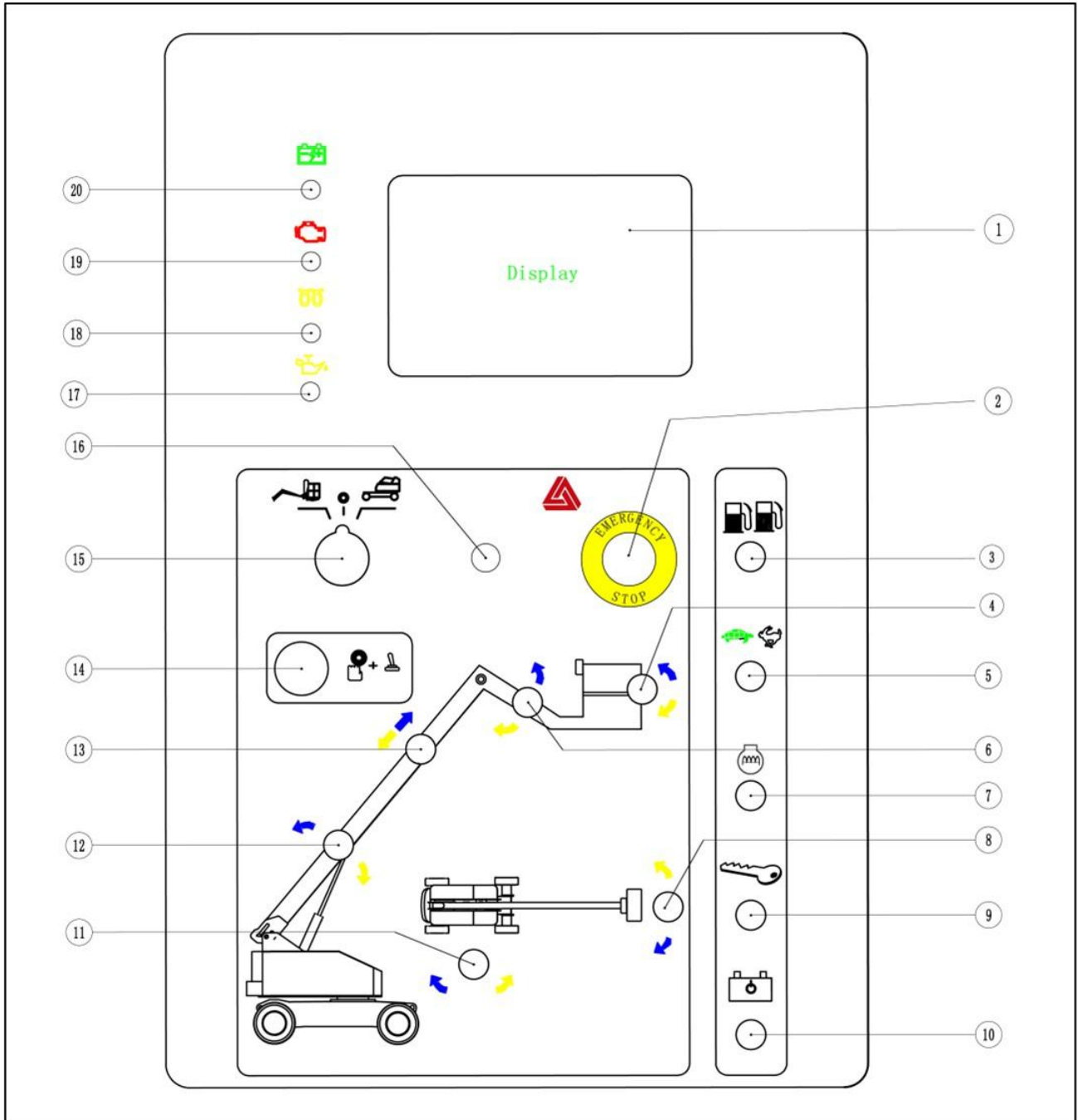

Figure 5-1 Panel of the lower control box

No.	Name	No.	Name
1	Display	11	Turntable rotary switch
2	Emergency stop switch	12	Boom up/down switch
3	Reserve	13	Boom extension/retraction switch
4	Platform leveling switch	14	Function enable button
5	Engine idle speed (rpm) selector switch	15	Key switch
6	Jib ascend/descend switch	16	self-resetting fuse for controlling circuit



Operation Manual of Telescopic Boom Mobile Elevating Work Platform

7	Reserve	17	Engine oil alarm (If equipped)
8	Platform rotary switch	18	Engine warm up indicator (If equipped)
9	Engine start switch	19	Engine failure alarm (If equipped)
10	Emergency power unit switch	20	Power on indicator (If equipped)

Table 5-1 Names of the functions of the lower control panel

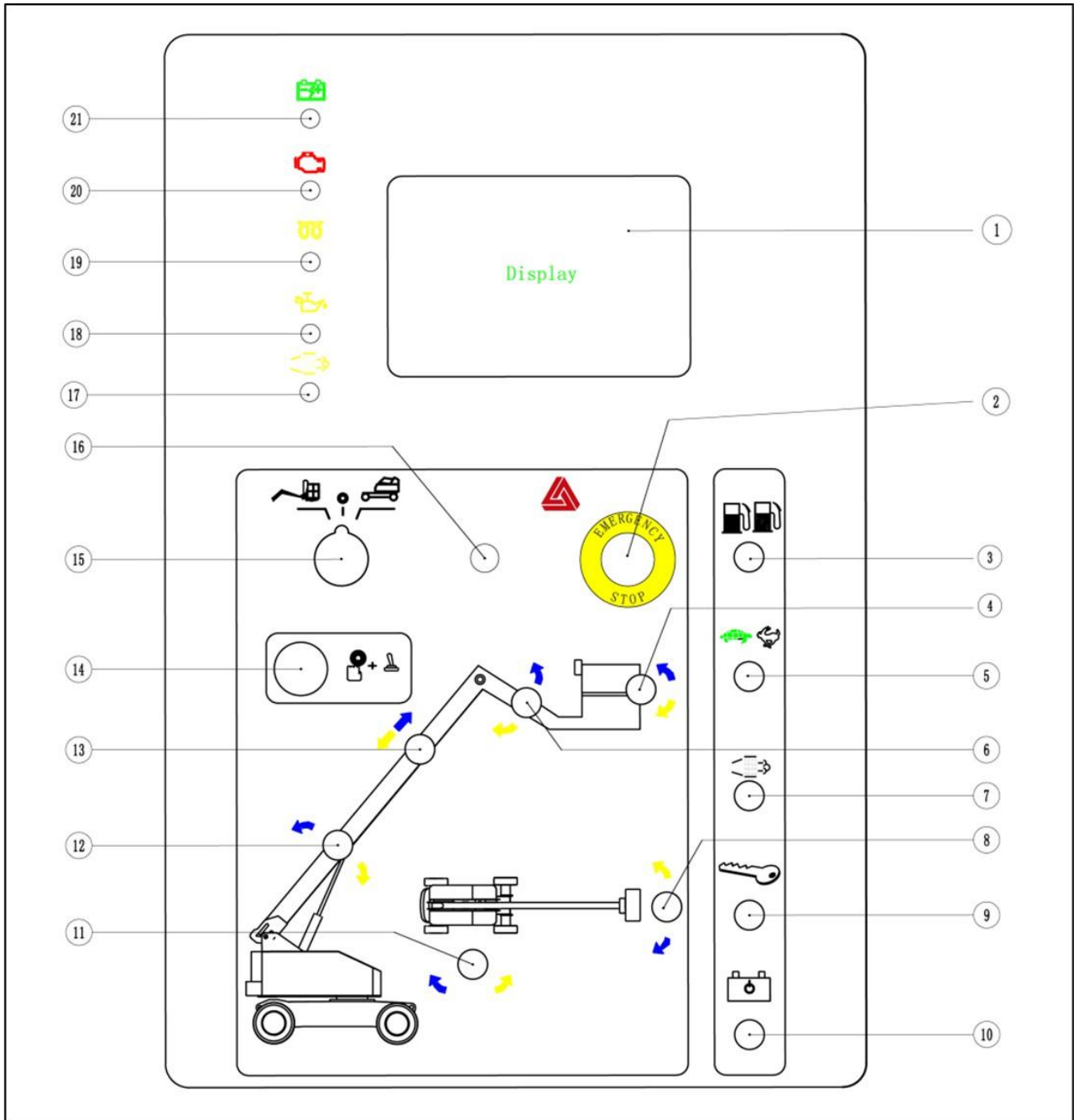

Figure 5-2 Panel of the lower control box

No.	Name	No.	Name
1	Display	11	Turntable rotary switch
2	Emergency stop switch	12	Boom up/down switch
3	Gasoline/LPG model: Fuel selector	13	Boom extension/retraction switch



**Operation Manual of Telescopic Boom
Mobile Elevating Work Platform**

	switch		
4	Platform leveling switch	14	Function enable button
5	Engine idle speed (rpm) selector switch	15	Key switch
6	Jib up/down switch	16	10A self-resetting fuse for controlling circuit
7	Manual DPF regeneration switch	17	Manual DPF regeneration indicator (If equipped)
8	Platform rotary switch	18	Engine oil alarm (If equipped)
9	Engine start switch	19	Engine warm up indicator (If equipped)
10	Emergency power unit switch	20	Engine failure alarm (If equipped)
		21	Power on indicator (If equipped)

Table 5-2 Names of the functions of the lower control panel



Operation Manual of Telescopic Boom Mobile Elevating Work Platform

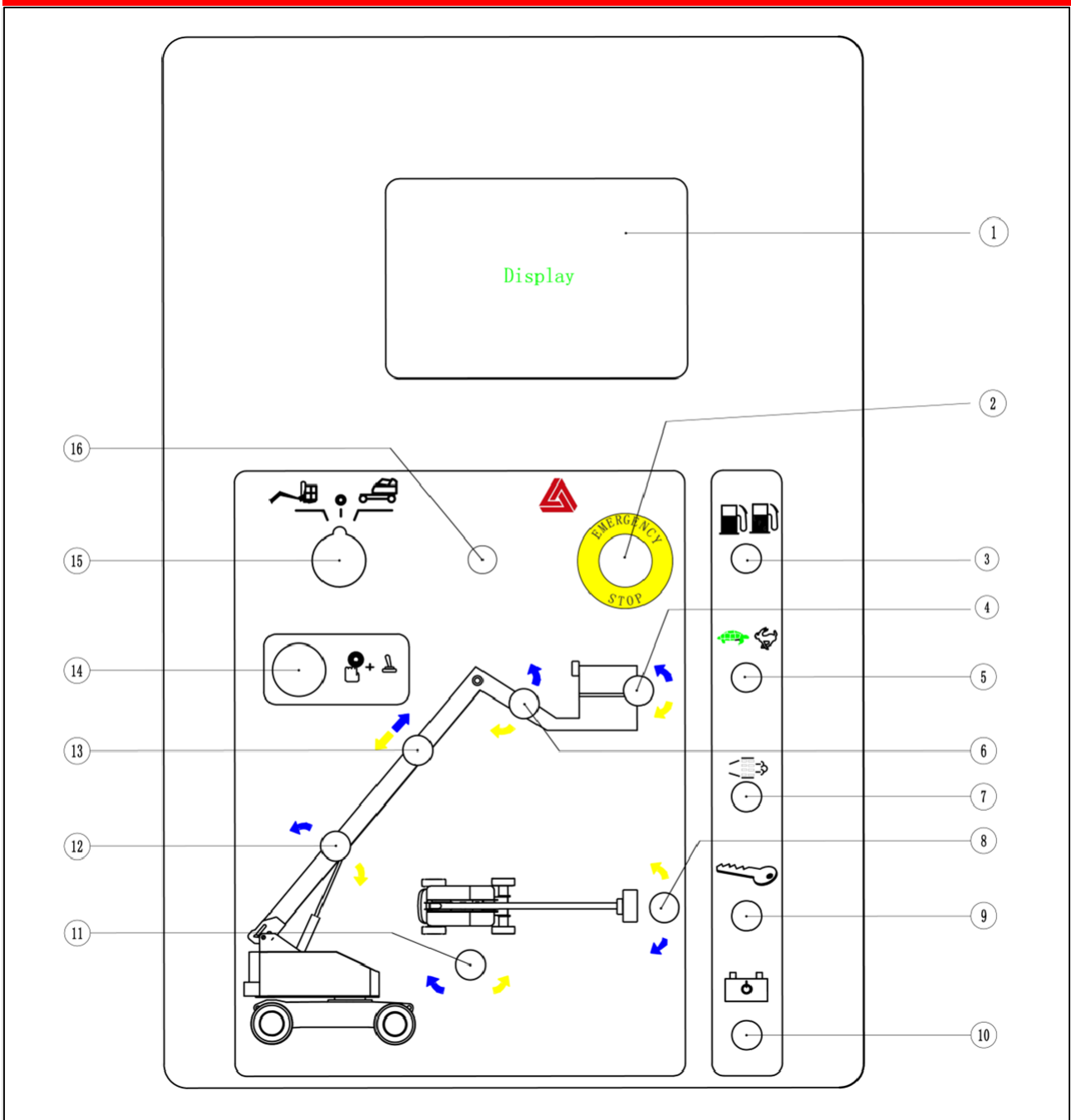

Figure 5-3 Panel of the lower control box (If equipped)

No.	Name	No.	Name
1	Display	9	Engine start switch
2	Emergency stop switch	10	Emergency power unit switch
3	Gasoline/LPG model: Fuel selector switch	11	Turntable rotary switch
4	Platform leveling switch	12	Boom up/down switch
5	Engine idle speed (rpm) selector switch	13	Boom extension/retraction switch
6	Jib up/down switch	14	Function enable button
7	Manual DPF regeneration switch	15	Key switch
8	Platform rotary switch	16	10A self-resetting fuse for controlling circuit

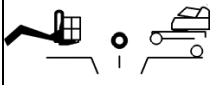

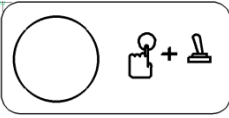



Table 5-3 Names of the functions of the lower control panel



Operation Manual of Telescopic Boom Mobile Elevating Work Platform

The table below describes the functions of the button/toggle switches:

Item	Button/Toggle Switch	Function Description
Lower control box	Key switch	 <p>Turn the key switch to the platform position, and the upper control box will work. Turn the key switch to the off position, and the machine will be turned off. Turn the key switch to the chassis position, and the lower control box will work.</p>
	Engine start switch	 <p>Move the engine start switch to one side for 2-3S to start the engine.</p>
	Emergency stop switch	 <p>Push the red "emergency stop" button inward to the off position to stop all functions; Rotate the red "emergency stop" button to the on position to operate the machine and the warning light flashes.</p>
	Function enabling button switch	 <p>If you do not press and hold the function enabling button switch, all boom and platform functions will not work. Press and hold the function enabling button switch and start each boom and platform function toggle switch to run all boom and platform functions.</p>
	Emergency power switch	 <p>If the main power source (engine) fails, please use the emergency power unit. Start the required function while keeping the emergency power unit switch on.</p>
	<ol style="list-style-type: none"> 1. Turn the key switch to the lower control box. 2. Rotate the red "emergency stop" button outward to the on position. 3. Press the function enable button. 	
	Platform rotary switch	Push the platform rotary toggle switch upward, the platform will rotate to the right; Push the platform rotary toggle switch downward, the platform will rotate to the left.
	Turntable rotary switch	Push the toggle switch to the right, the turntable will move to the right; Push the toggle switch to the left, the turntable will move to the left.
	Boom up/down switch	Push the toggle switch up, the boom will rise; Push the toggle switch down, the boom will descend. When the boom descends, the buzzer should sound; When the boom is swung to the maximum and minimum positions, the buzzer will sound.
	Boom extension/retraction switch	Push the toggle switch up, the boom will extend; Push the toggle switch down, the boom will retract. When the boom extends and retracts to the maximum position, the buzzer will sound.
	Jib up/down switch	Pull the toggle switch up, the Jib will rise; Push the toggle switch down, the Jib will descend.
Platform leveling switch	Pull the platform leveling toggle switch up, the platform level will rise. Push the platform leveling toggle switch down, the platform level will descend.	



Operation Manual of Telescopic Boom Mobile Elevating Work Platform



	Engine idle speed selector switch	 	Pull the idle speed selector switch to the turtle position, the engine starts the low idle speed; Pull the idle speed selector switch to the rabbit position, the engine starts the high idle speed. After releasing the function enable button, the engine enters the low idle speed.
--	-----------------------------------	---	--

Table 5-4 Description of functions of the toggle switches on the lower control box panel



5.2 Upper Control Box

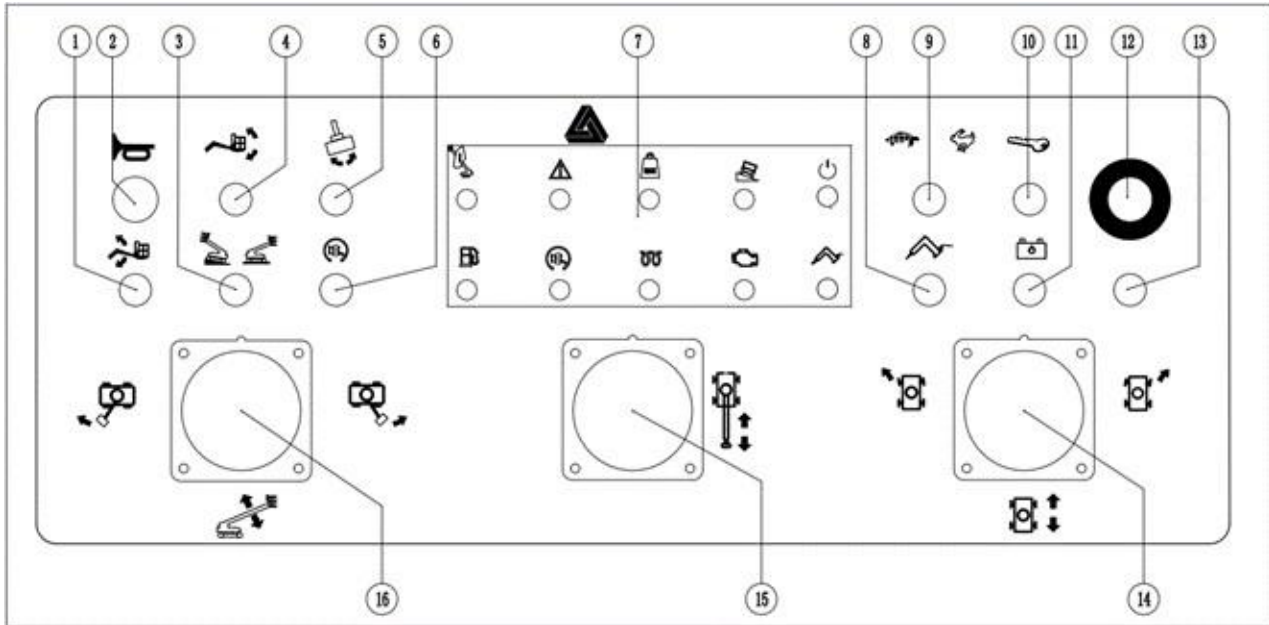

Figure 5-4 Panel of the upper control box (If equipped)

Serial Number	Name	Serial Number	Name
1	Jib up/down switch	9	Engine idle speed selector switch
2	Horn switch	10	Engine start
3	Drive speed selector switch	11	Emergency power unit switch
4	Platform leveling switch	12	Emergency stop switch
5	Platform rotary switch	13	Reserve
6	Drive enabling switch	14	Drive/steering control handle
7	Indicator light	15	Boom extension and retraction
8	Generator switch(If equipped)	16	Boom up/down and turntable rotary switch

Table 5-5 Names of the functions of the upper control box panel



Operation Manual of Telescopic Boom Mobile Elevating Work Platform

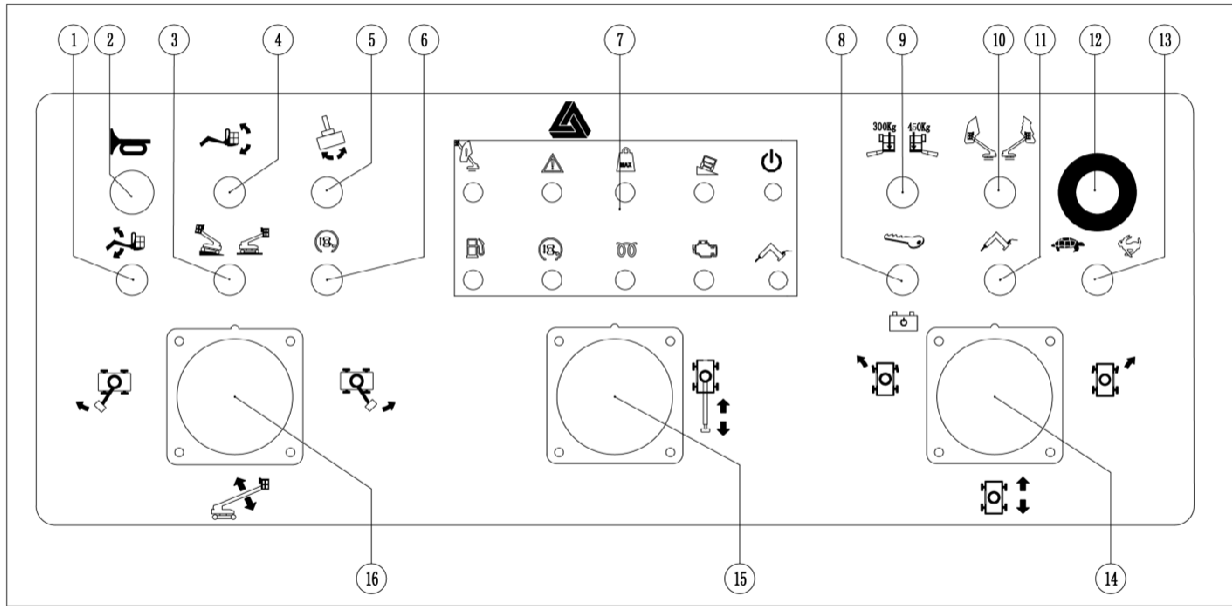

Figure 5-5 Panel of the upper control box (If equipped)

Number	Name	Number	Name
1	Jib up/down switch	9	Load selection switch
2	Horn switch	10	Working range selection switch (reserve)
3	Drive speed selector switch	11	Generator switch(If equipped)
4	Platform leveling switch	12	Emergency stop switch
5	Platform rotary switch	13	Engine idle speed selector switch
6	Drive enabling switch	14	Drive/steering control handle
7	Indicator light	15	Boom extension and retraction
8	Engine start/ Emergency power unit switch	16	Boom up/down and turntable rotary switch

Table 5-6 Names of the functions of the upper control box panel



Operation Manual of Telescopic Boom Mobile Elevating Work Platform

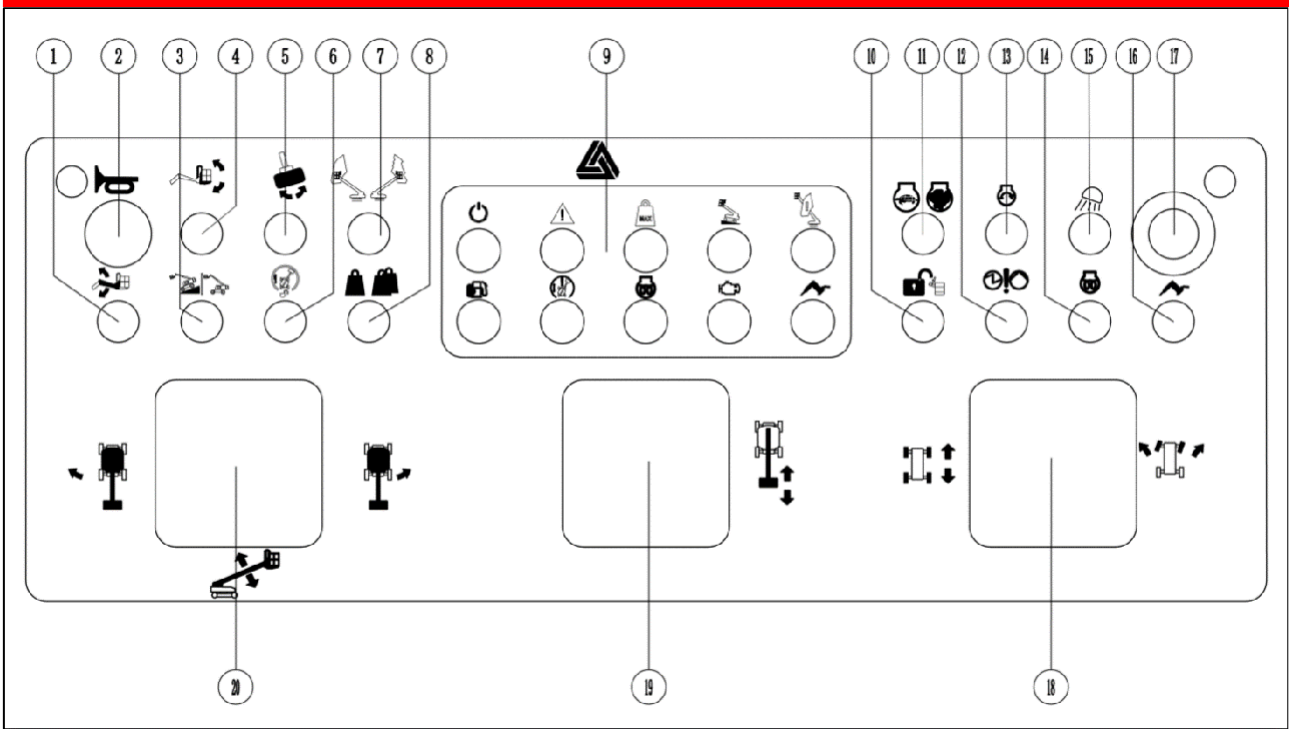

Figure 5-6 Panel of the upper control box (If equipped)









Number	Name	Number	Name
1	Jib up/down switch	11	Engine idle speed selector switch
2	Horn switch	12	Emergency power unit switch
3	Drive speed selector switch	13	Engine start switch
4	Platform leveling switch	14	Reserve
5	Platform rotary switch	15	Boom lamp(If equipped)
6	Drive enabling switch	16	Generator switch(If equipped)
7	reserve	17	Emergency stop switch
8	Load selection switch	18	Drive/steering control handle
9	Indicator light	19	Boom extension and retraction handle
10	Override switch (Reserve)	20	Boom up/down and turntable rotary handle

Table 5-7 Names of the functions of the upper control box panel

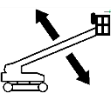

Operation Manual of Telescopic Boom Mobile Elevating Work Platform

The table below describes the functions of the button/toggle switches on the upper control box.

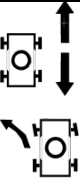
Item	Button/Toggle Switch	Function Description
Upper control box	Engine start switch	 <p>Move the engine start switch to one side to start the engine.</p>
	Emergency stop switch	 <p>Push the red "emergency stop" button inward to the off position, you can stop all upper control functions and shut down the engine without any impact on the lower control box. Rotate the red "emergency stop" button to the on position, you can operate the machine on the upper control box.</p>
	<ol style="list-style-type: none"> 1. Turn the key switch to the upper control box. 2. Pull the red "emergency stop" button outward to the on position. 3. Step on the foot switch. 	
	Platform rotary toggle switch	 <p>Rotate the platform rotary toggle switch to the right, the platform will rotate to the right. Rotate the platform rotary toggle switch to the left, the platform will rotate to the left.</p>
	Boom up/down and turntable rotary handle	 <p>Move the control handle to the right, the turntable will move to the right. Move the control handle to the left, the turntable will move to the left.</p>
		 <p>Move the control handle up, the boom will rise; Move the control handle downward, the boom will descend. When the boom descends, the buzzer should sound; When the boom is swung to the maximum and minimum positions, the buzzer will sound.</p>
	Boom extension/retraction	 <p>Pull the control handle down, the boom extends; Push the control handle up, the boom retracts. When the boom extends and retracts to the maximum position, the buzzer will sound.</p>
	Jib up/down toggle switch	 <p>Pull the toggle switch up, the Jib will rise; Push the toggle switch down, the Jib will descend. When the Jib descends, the buzzer will sound;</p>
	Platform leveling toggle switch	 <p>Pull the platform leveling toggle switch up, the platform level will rise; Push the platform leveling toggle switch down, the platform level will descend.</p>
Drive/steering control handle	 <p>Move the control handle upward, the machine will drive forward; Move the control handle down, the machine will drive backward. Press the left side of the thumb stick, the machine will turn to the left; Press the right side of the thumb stick, the machine will turn to the right.</p>	



Operation Manual of Telescopic Boom Mobile Elevating Work Platform







Drive speed selector switch	 <p>When the machine is on the slope symbol, it is used for driving the operation in the low speed range. At this time, the engine automatically switches to the high idle speed; When the machine is in the horizontal plane symbol, it is used for driving the high speed operating range.</p>
Drive enabling switch	 <p>When the turntable is rotated to a certain angle, the drive function cannot be operated and the drive enabling indicator alarms. Move the drive enabling toggle switch to one side and slowly move the drive controller handle, then the drive function will operate.</p>
Engine idle speed selector switch	 <p>Pull the idle speed selector switch to the turtle position, the engine starts the low idle speed; Pull the idle speed selector switch to the rabbit position, step on the foot switch and turn the handle, then the engine starts the high idle speed. After releasing the handle, the engine enters the low idle speed.</p>
Emergency power switch	 <p>If the main power source (engine) fails, please use the emergency power unit. Step on the foot switch to start the required functions while keeping the emergency power switch on.</p>
Generator switch (If equipped)	 <p>To operate the generator, move the generator toggle switch to the on position. To stop the generator, move the generator toggle switch to the off position.</p>
Load selection switch(T22J/T26J)	 <p>Move the switch to the left side, the platform rated load is 300kg(T22J)/250kg(T26J); move the switch to the right side, the platform maximum load is 450kg(T22J)/340kg(T26J). (The working range is shown in Figure 4-8).</p>

Table 5-8 Description of the functions of the toggle switches on the upper control box panel



Operation Manual of Telescopic Boom Mobile Elevating Work Platform

The table below describes the functions of the LED display panel and indicators:











	Power on indicator		Limited range of motion
	Platform overweight alarm		Minimum fuel level alarm
	Drive enabling alarm		System failure alarm
	Machine tilt alarm		Engine failure alarm
	Generator is in use		Glow plugs are on

Table 5-9 Description of the functions of the LED display panel



5.3 Control Logic (SPD)

After the SPD is triggered, use the platform controls to operate the machine without using the override function, and all functions cannot operate; use the platform controls to operate the machine with using the override function, and the boom can be lowered and retracted but cannot be raised or extended, the turntable cannot be swung, the jib can be lowered but cannot be raised, the platform cannot be rotated or leveled, and the complete machine can travel and steer. After the SPD is triggered, use the ground controls to operate the machine, and all functions except for the traveling and steering functions can operate. The control logic is shown in the table below.

SPD Activated

Position	Platform	Platform	Ground
Power	Main power	Main power	Main power
Status	NO override	Override	NO override
Primary Up Secondary Up	x	x	√
Primary Down Secondary Down	x	√	√
Primary Extend Secondary Extend	x	x	√
Primary Retract Secondary Retract	x	√	√
Turntable Swing	x	x	√
Jib Up	x	x	√
Jib Down	x	√	√
Platform Rotate	x	x	√
Platform Level Up	x	x	√
Platform Level down	x	x	√
Drive	x	√	—
Steer	x	√	—



Chapter 6 Pre-Operational Check





6.1 Before Operating the Machine, Please Ensure that:

- 1) You are equipped with full-body protective equipment such as helmets, safety belts, safety shoes, goggles and protective gloves, and are in good physical condition.
- 2) You have understood and practiced the rules for safe operation of the machine in this operation manual.
- 3) To avoid dangerous situations, you know and understand the safety rules before moving to the next step.
- 4) To check the workplace, please refer to the workplace inspection section of this manual.
- 5) You read, understand and abide by all applicable government laws and regulations.
- 6) You are properly trained and qualified to operate the machine safely.
- 7) Only qualified maintenance technicians can repair the machine according to our company's regulations.

6.2 Basic Principles

- 1) It is the operator's responsibility to conduct pre-operational check and routine maintenance.
- 2) Pre-operational check is an intuitive inspection process that is performed by the operator before each shift. The purpose of inspection is to find out whether there is a significant problem with the machine before the operator performs a functional test.
- 3) Pre-operational checks can also be used to determine whether a routine maintenance procedure is required. The operator can only perform routine maintenance items as specified in this manual.
- 4) Please refer to the list on the next page and check each item.
- 5) If damage or any unauthorized changes different from the factory state are found, mark the machine and stop using it.
- 6) Only qualified maintenance technicians can

repair the machine. After the repair is completed, the operator must perform a pre-operational check before continuing the functional test.

- 7) Regular maintenance inspections shall be performed by qualified maintenance technicians in accordance with the manufacturer's specifications and the requirements listed in the manual.

6.3 Pre-Operational Check

- 1) Ensure that the manual is complete, easy to read and kept in a file box in the platform. If you need to replace the manual, please contact the service personnel from LGMG.
- 2) Ensure that all labels are clear, legible and in the right place. Please refer to the "labels" section. If you need to replace the labels, please contact the service personnel from LGMG.
- 3) Check whether the two ball valves at the oil suction port at the bottom of the hydraulic oil tank are open. They must be kept open if there are no any special circumstances, and they must be in an open state when the engine starts. Failure to open the valve before starting the engine will cause complete damage to the oil pump.
- 4) Please refer to the "maintenance" section to check whether the hydraulic oil is leaking and whether the oil level is appropriate.
- 5) Check whether the battery fluid leaks and the wiring is firm.
- 6) Please refer to the "Maintenance" section to check whether the engine oil is leaking and whether the oil level is appropriate.
- 7) Check whether the engine fuel leaks and the oil level is appropriate. When the fuel indicator lights up, please refuel in time.
- 8) Check the engine indicator. If the indicator is on, immediately ensure that the engine is off, mark the machine and check the engine thoroughly with reference to the maintenance manual.
- 9) Check the following parts for damage, improper installation, loose or missing parts and unauthorized changes:



- Electrical plugs, wiring and cables
 - Boarding controller, getting-off controller
 - Platform control handle
 - Tilt angle sensor, long angle sensor and weighing sensor
 - Display, alarm indicator, flashing light, horn, buzzer, broken rope limit switch and drive enabling limit switch
 - Valve block, hose, hydraulic joint, cylinder, motor and reducer
 - Fuel tank and hydraulic oil tank, hydraulic oil cooler
 - Wear pad, tire and slewing bearing
 - Nuts, bolts and other fasteners
 - Platform entrance lift
- 10) Check the complete machine to find:
- Crack in a weld or structural member
 - Dent or damage to the machine
 - Severe rust, corrosion or oxidation

Ensure that all structural members and other critical components are complete and that all relevant fasteners and pins are in the correct position and tightened. After completing the inspection, ensure that the hood is properly positioned and locked.

6.4 Pre-operation Inspection of Safety Protection Devices (SPD)

- 1) Check the following components for damage, improper installation, loose or missing parts, and unauthorized changes:
 - Electrical plugs, wiring and cables
 - Display screen, alarm indicator light, strobes, horn, buzzer
 - Nuts, bolts and other fasteners
 - Platform entrance lever
 - Platform safety protection device
- 2) Check to ensure that all structural components and other critical components of the SPD are intact, and that all relevant fasteners and pins are in correct positions and tightened.
- 3) Check to ensure that there are no foreign objects in the SPD grooves.
- 4) Check that the SPD's function is normal, and the machine can be operated normally via the verification procedures.
- 5) If any unauthorized changes from the factory delivered condition or damages are found, the machine must be tagged out and removed from use.



6.5 Machine inspection diagram

Check each structural securement point on the machine in strict accordance with the illustration. Once a loose, broken, rusted or missing bolt or deformed or dislodged pin is found, immediately tag the abnormal location and remove the equipment from service. Never operate the malfunctioning equipment.

In addition to the specified check points below, comprehensively verify: whether any component is loose, broken, cracked or missing and securement is firm; and whether hydraulic lines are excessively worn, broken or leaky and harnesses are broken or damaged. Be sure each machine function operates properly.

⚠ Remember to check the bottom side of the machine! Failure to do so could cause safety accidents, resulting in equipment damage and personal injury or death.

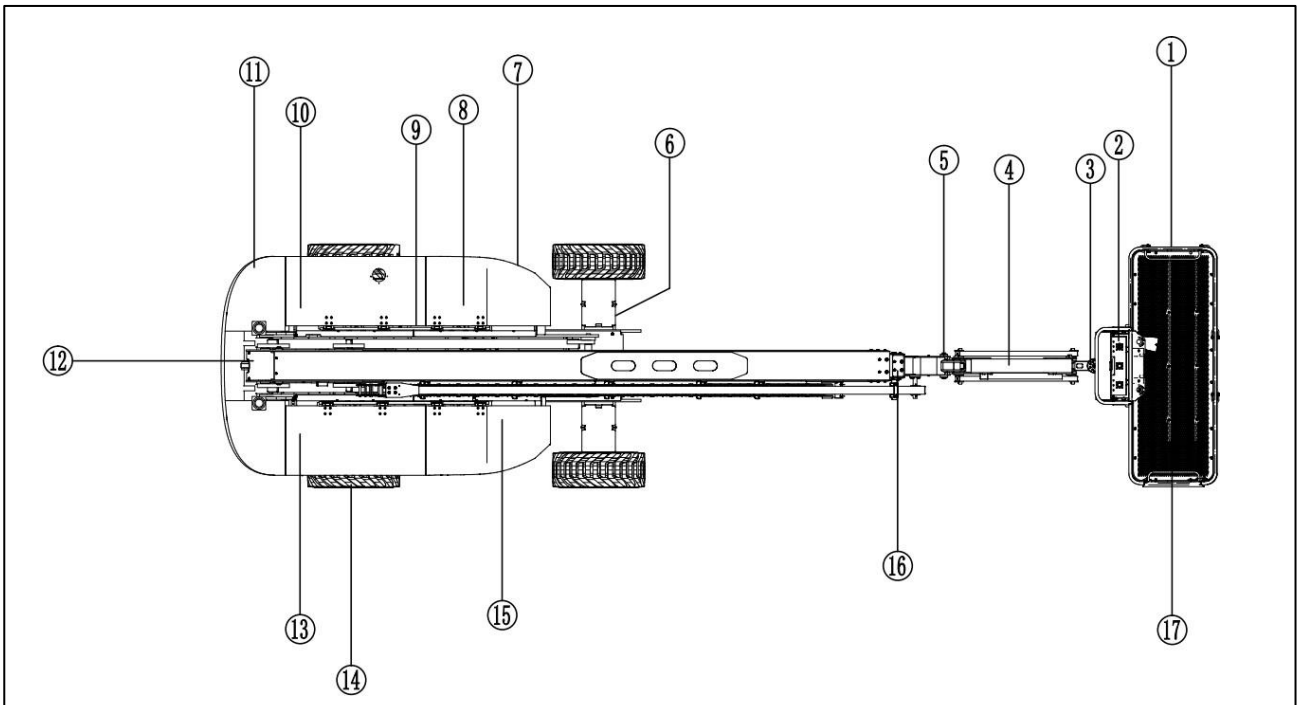

- 1) Gate and sliding midrail with U-bolts: Check the gate lock and hinge and the midrail bolts. Use extreme care to prevent personnel fall from the platform due to their malfunction.



- 2) PCU securement: Check the bolt condition. Use extreme care to prevent PCU dislodgement due to the bolt breakage.
- 3) Platform rotation device: Check the bolt condition. Use extreme care to prevent the platform fall or overturn due to jib boom separation from the platform.
- 4) Cylinder lockout valve securement. Check the bolt condition. Use extreme care to prevent unexpected boom fall due to the bolt breakage, which will result in personnel fall.
- 5) Boom pin securement. Check the bolt condition and the pin installation. Use extreme care to prevent the boom overturn due to the bolt breakage or pin dislodgement.
- 6) Axle securement: Check the pin installation. Use extreme care to prevent the axle separation from the chassis due to the pin dislodgement, which will cause the machine to tip over.
- 7) Hood assembly securement. Check the bolt installation. Use extreme care to prevent the hood fall due to the bolt breakage.
- 8) Swing drive securement: Check the bolt condition. Use extreme care to prevent the swing drive fall due to the bolt breakage.
- 9) Swing bearing and chassis/turntable securement: Check the bolt condition. Use extreme care to prevent the chassis/turntable separation from the swing bearing due to the bolt breakage, which will cause the turntable to overturn.
- 10) Engine assembly securement: Check the bolt condition. Use extreme care to prevent the engine fall due to the bolt breakage.
- 11) Counterweight assembly securement: Check the bolt condition. Use extreme care to prevent the counterweight fall due to the bolt breakage.
- 12) Boom extend/retract steel wire rope connection: Use extreme care to prevent the boom fall due to the nut dislodgement and rope looseness/breakage.
- 13) Hydraulic tank assembly securement: Check the bolt condition. Use



extreme care to prevent the tank fall due to the bolt breakage.

- 14) Tire securement: Check the tire bolts for tightness. Use extreme care to prevent the tire dislodgement due to the nut looseness.
- 15) Fuel tank assembly securement: Check the bolt condition. Use extreme care to prevent the tank fall due to the bolt breakage.
- 16) Level and load capacity limit switch: Check to make sure the switch functions properly. Use extreme care to prevent the machine instability or tip-over due to the switch failure.
- 17) Platform securement: Check the bolt condition. Use extreme care to prevent the platform separation from its support due to the bolt breakage, which will cause the platform fall or tip-over.





Chapter 7 Workplace Inspection





7.1 Basic Principles

- 1) Workplace inspection helps the operator to determine whether the workplace is safe for operation. The operator should do this work before moving the machine to the workplace.
- 2) It is the operator's responsibility to understand and remember the hazards in the workplace so that he/she can be aware of and avoid these problems when moving, installing and operating the machine.

7.2 Workplace Inspection

Beware of and avoid the following dangerous situations:

- Steep slope or cave
- Protruding objects, ground obstacle or debris
- Inclined surface
- Insecure or smooth surface
- Aerial obstacles and high voltage wires
- A surface support that is not sufficient to withstand the full load exerted by the machine
- The instantaneous wind speed exceeds 12.5m/s.
- If the ambient temperature and humidity exceed the required temperature and humidity requirements, please refer to the working conditions in the machine parameters section of this manual.
- The presence of unauthorized personnel
- Other possible unsafe situations





Chapter 8 Functional Test





8.1 Basic Principles

- 1) You have understood and practiced the rules for safe operation of the machine in this operation manual.
- 2) According to on-site needs, you have been equipped with full-body protective equipment such as helmets, safety belts, safety shoes and goggles, and are in good physical condition.
- 3) Choose a test area that is solid, level and free of obstructions.
- 4) To avoid dangerous situations, you know and understand the safety rules before moving to the next step.
- 5) Functional tests are used for detecting faults before starting to use the machine.
- 6) The operator must follow the procedure to test all the functions of the machine.
- 7) It's forbidden to use a malfunctioning machine. If a fault is found, the machine must be marked and stopped.
- 8) Only qualified maintenance technicians can repair the machine according to our company's regulations.
- 9) After the repair, the operator must perform the pre-operational check and functional test again before starting to use the machine.

8.2 At the Ground Controller

- 1) Turn the key switch to the position of the lower control box.
- 2) Rotate the red "emergency stop" button to the "ON" position, and the warning light will begin to flash.
- 3) Please refer to the "Operation Instructions" section to start the engine.
- 4) Test the emergency stop
 - Rotate the red "emergency stop" button inward to the "off" position.

Result: The engine is off and none of the functions work.

- Pull the red emergency stop button to the "on" position to restart the engine.

- 5) Test the machine function

- Do not press and hold the function enabling button switch. Try to enable each boom and platform function toggle switch.

Result: All boom and platform functions are not operational.

- Press and hold the function enabling button switch and start each boom and platform function toggle switch.

Result: All boom and platform functions run for a full cycle. When the platform descends, the buzzer sounds.

- 6) Test the function of the emergency power unit.



CAUTION: Perform this step

when the engine is off. In order to save battery energy, test each function in half a cycle.

- Turn the key switch to the ground control and rotate the red emergency stop button to the "on" position.
- At the same time, press the emergency power unit switch to the on position and start each arm function switch.

Result: All boom functions are operational.

- 7) Inspect the automatic leveling of the work platform.

- Start the engine from the ground.
- Press the function enable switch and use the platform leveling toggle switch to adjust the work platform to the horizontal position.
- Raise and descend the boom through a full cycle.

Result: The work platform is always level.

8.3 On the Platform

- 1) Test emergency stop

- Turn the key switch to the platform controller.

- Enter the platform to pull out the red "emergency stop" button and start the engine.



Operation Manual of Telescopic Boom Mobile Elevating Work Platform

- Push the red "emergency stop" button of the platform to the off position.

Result: The engine is off and no function can be operated.

2) Test the horn

- Press the horn button.

Result: The horn sounds.

3) Test the foot switch

- Push the red "emergency stop" button of the platform to the off position.
- Rotate the red "emergency stop" button to the on position and do not start the engine.
- Press down the foot switch and try to start the engine by pulling the start toggle switch to upper side.

Result: The engine does not start.

- Do not press the foot switch and restart the engine.
- Do not press the foot switch and test the machine's actions.

Result: None of the actions are running.

4) Test the machine function

- Press down the foot switch.
- Start each function control handle or toggle switch on the machine.

Result: All boom/platform actions work properly in one full cycle.

5) Test the auxiliary power function



CAUTION: Perform this step when the engine is off. In order to save battery energy, test each function in half a cycle.

- Turn the key switch to the work platform control.
- Turn the red emergency stop button to the "on" position on the work platform control and press the foot switch.
- Press the emergency power unit switch to the "on" position and turn on each function control handle or toggle switch.

Result: All arm and steering functions.

Drive functions do not function.

6) Test the steering

- Press down the foot switch.
- Press the left side of the thumb stick switch on the top of the drive control handle.

Result: The steering wheel rotates in the direction indicated by the colorless arrow on the drive chassis.

- Press the right side of the thumb stick switch on the top of the drive control handle.

Result: The steering wheel rotates in the direction indicated by the yellow arrow on the drive chassis.

7) Test the drive and brake function

- Press down the foot switch.
- Move slowly the drive control handle forward until the machine begins to move, and then return the handle to the center position.

Result: The machine should move in the direction indicated by the colorless arrow on the drive chassis and then stop suddenly.

- Move slowly the drive control handle backward until the machine begins to move, and then return the handle to the center position.

Result: The machine should move in the direction indicated by the yellow arrow on the drive chassis and then stop suddenly.



CAUTION: The brakes must be able to stop the machine on any slope that it can climb.

8) Test the tilt angle sensor

- Start the engine and drive the machine to a certain slope, then make the turntable tilt 4.5° along the direction of the boom, which has an upward variable amplitude of 5° or an extension of 0.6m.

Result: The alarm on the platform sounds.

- Drive the machine to a certain slope, and then make the turntable tilt 4.5° along the



vertical direction of the main arm, which has an upward variable amplitude of 5° or an extension of 0.6m.

Result: The alarm on the platform sounds.

- Drive the machine to a certain slope to make the buzzer sound.
- Start all boom functions in succession.
- Operate the handle to start the turntable rotary function.

Result: The upward variable amplitude of the boom cannot continue after reaching the position of 5° above the horizontal plane. The boom cannot continue to extend after an extension of 0.6m. The rest of the boom functions can be used normally, the turntable cannot be rotated and the drive function cannot be used.



CAUTION: If the turntable tilts 4.5°

along the direction of the boom or 4.5° along the vertical direction of the boom, the boom can rise to 5° above the horizontal plane or the boom can extend more than 0.6 m. The machine should be marked immediately and stopped using.

9) Test the floating cylinder

- Start the engine on the platform.
- Drive the right steering wheel to a 0.10m high obstacle or curb.

Result: The other three tires are in close contact with the ground.

- Drive the left steering wheel to a 0.10m high obstacle or curb.

Result: The other three tires are in close contact with the ground.

- Drive the left rear wheel to a 0.10m high obstacle or curb.

Result: The other three tires are in close contact with the ground.

- Drive the right rear wheel to a 0.10m high obstacle or curb.
- Result: The other three tires are in close

contact with the ground.

10) Test the drive enabling system



Figure 8-1 Drive enabling

- Press down the foot switch and descend the boom to the retracted state.
- Rotate the turntable until the boom is turned to a certain angle, as shown in Figure 8-1.

Result: The drive enabling indicator should be illuminated when the boom is at any position within the range shown.

- Move the drive control handle away from the center position.

Result: The drive function does not work.

- Move the drive enabling toggle switch to the upper side while slowly moving the drive controller handle away from the center position.

Result: The drive function operates and the maximum drive speed that can be achieved does not exceed 0.8km/h.



CAUTION: When using the drive enabling system, the machine may travel in the opposite direction of travel and steering control handle movement. Use the color-coded direction arrows on the drive chassis to determine the direction of movement.

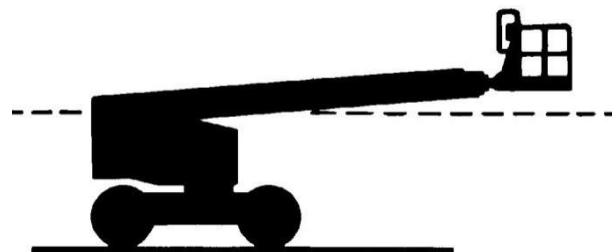

11) Test the limited drive speed

Figure 8-2 Drive limit



- Press down the foot switch.
- Raise the boom to 5° above the horizontal plane.
- Move slowly the drive control handle to the full drive position.

Result: When the boom is lifted, the maximum drive speed that can be achieved does not exceed 0.8km/h.

- Descend the boom to the retracted state.
- Extend the boom by about 0.6m.
- Move slowly the drive control handle to the full drive position.

Result: When the boom is in the extended state, the maximum drive speed that can be achieved does not exceed 0.8km/h.



CAUTION: If the drive speed of the boom when it is raised or extended exceeds 0.8km/h, the machine should be marked immediately and stopped.

12) Test the limited rotary speed of the turntable

- Press down the foot switch.
- Raise the boom to 5° above the horizontal plane.
- Move slowly the turntable control handle to the full drive position.

Result: The time it takes the boom to rotate for a circle in the extended state is not less than 125S (T20J/T22J)/170S (T26J).

- Descend the boom to the retracted state.
- Extend the boom by about 0.6m.
- Move slowly the turntable control handle to the full drive position.

Result: The time it takes the boom to rotate for a circle in the extended state is not less than 125S (T20J/T22J)/170S (T26J).



CAUTION: If the time it takes the boom to rotate for a circle in the extended state is less than 125S (T20J /T22J)/170S (T26J), the machine should be marked immediately and stopped.

13) Test the platform overload

- T20J: Load more than 250 kg of weight on the platform.
- T22J/T26J: Load more than 300kg (T22J) /250kg (T26J) (under the mode that the range of motion of the boom is not restricted) or 450kg (T22J)/340kg (T26J) (under the mode that the range of motion of the boom is restricted) weight on the platform.

Result: The indicator lamp is ON, the buzzer sounds, and the machine can't move.

- Remove the load on the platform until the indicator lamp goes out.

Result: The machine can be operated.

14) Test the drive/boom function

- Press down the foot switch.
- Move the drive control handle away from the center position and start a boom function handle or toggle switch.

Result: The machine moves in the direction indicated on the control panel.

All boom functions should not be operational.

8.4 Verification Procedures for Safety Protection Devices (SPD)

- 1) After the machine is powered on, press down the foot switch, operate the joystick, and disengage the safety rod from the proximity switch.
 - ✓ Result: The strobes should flash, the horn should sound intermittently and then keep sound, and no functions should operate.
- 2) Release the foot switch, restore the safety rod, press down the foot switch, and operate the joystick.
 - ✓ Result: The strobes should be off, the horn should stop, and all functions should operate normally.



Chapter 9 Operation Instructions





9.1 Basic Principles

- 1) This machine is hydraulically-driven aerial work equipment that is equipped with a work platform on a straight arm mechanism. This machine can be used to load workers and their portable tools to a certain height from the ground, or to reach a certain work area above the machine or equipment.
- 2) The operation instructions section provides specific instructions for all aspects of the operation of the machine. It is the operator's responsibility to follow all safety rules and instructions in the operation manual.
- 3) It is unsafe and even dangerous to use this machine for any purpose other than lifting people and their tools and materials to the aerial workplace.



WARNING: This machine is

strictly prohibited from carrying goods or using as a crane.

- 4) Only trained and authorized personnel can operate the machine. If more than one operator uses the same machine at different times during the same shift, they must all be qualified operators and follow all safety rules and instructions in the operation manual. This means that every new operator should perform pre-operational checks, functional tests and workplace inspections before operating the machine.

9.2 Starting up the Engine

- 1) On the lower control box, turn the key switch to the required position.
- 2) Ensure red "Emergency Shutdown" buttons on the lower control box and the upper control box are pulled to the ON position.
- 3) The engine can be automatically preheated at low temperatures when the whole vehicle is powered on.
- 4) If the primary preheating cannot meet the requirements, press the emergency stop switch of ground control unit and then pull it

out, and then perform the preheating operation again.

- 3) Turn the startup toggle switch of the engine to upper side for 2s to 3s. In the case of failure to startup or halt for the engine, disenable the startup switch for 30s during startup.
- 4) In the case of failure to startup of the engine upon 15s, please find out the reason and repair the fault. Prior to retry of startup, wait for 60s.
- 5) After starting the engine, keep the engine at idle speed for 5 min prior to operation to prevent damage to the lubrication system for the engine.
- 6) At temperature lower than -18°C , try to start up the engine, and boosting battery may be used.



CAUTION: Upon the normal

running of the engine, do not start up again.

9.3 Emergency Shutdown

- 1) Push the red emergency shutdown button on the ground or upper control box to the "OFF" position to stop all functions and shut down the engine.
- 2) If any operational functions need to be fixed, it is necessary to implement after pressing the red "Emergency Shutdown" button.
- 3) Select and operate the red "Emergency Shutdown" button of the lower control box to shut down the platform.
- 4) Allow the engine to idle for 5 minutes before shutting it off after a full load operation. Failure to do so may lead to turbo-charger trouble.

9.4 Auxiliary Power

Where there is a fault in primary power source (engine), please use auxiliary power.

- 1) Turn the key switch to the ground or platform for control.
- 2) Pull out the red "Emergency Shutdown"



button to the "ON" position.

- 3) Start up the required function while keeping turning on the emergency power unit switch, and step down the pedal switch when operating on the platform.
- 4) Disenable the driving function when using auxiliary power, and enable steering and all arm lever functions.
- 5) The accumulative usage time of auxiliary power shall not exceed 30min.

9.5 Operating the Machine on Ground

- 1) Turn the key switch to the lower control box.
- 2) Turn the red "Emergency Shutdown" button on the lower control box to the "ON" position.
- 3) Turn the startup toggle switch of the engine to upper side for 2s to 3s, followed by starting up the engine.
- 4) Adjust platform position
 - Press and hold the function enabling button.
 - Move the proper toggle switch according to the mark on the control panel, and adjust the platform to the suitable position. Driving and steering functions cannot be used on the ground.
- 5) Selection of engine idle speed
 - Select engine idle speed with the sign on the control panel.

Turtle sign: Press the function enabling button to activate low idle speed.

Rabbit sign: Press the function enabling button, and turn the toggle switch to activate high idle speed.

- In the case of failure to turning of toggle switch, the engine will keep idle speed at the lowest revolution.

9.6 Operating the Machine on the Platform

- 1) Turn the key switch to the upper control

box.

- 2) Turn the red "Emergency Shutdown" buttons on the ground and the platform to the "ON" position.
- 3) Turn the startup toggle switch of the engine to the upper side for 2s to 3s, followed by starting up the engine. Do not step down the pedal switch when starting up the engine.
 - 1) Adjust platform position
 - Step down the pedal switch.
 - Slowly turn corresponding the function control handle or the toggle switch as per the mark on the control panel.
 - 2) Steering
 - Step down the pedal switch.
 - Turn the steering wheel by driving the thumb rocker button on the top of the control handle. Press the button on the left side of the thumb rocker, the steering wheel of the machine will turn left; and press the button on the right side of the thumb rocker, the steering wheel of the machine will turn right.



CAUTION: Determine the steering direction of wheel using color label direction arrows on the upper control box and the driving chassis.

- 3) Driving
 - Step down the pedal switch.
 - Increase the speed: Slowly move the driving controller handle, making it off center.
 - Decrease the speed: Slowly move the driving controller handle, making it point at the center.
 - Stop: Make the driving control handle return to the center or release the pedal switch.
 - When arm lever rises to the horizontal plane by more than 5° or extends out of 0.6m, the moving speed of machine doesn't exceed 0.8km/h.



CAUTION: Determine the direction



of driving the machine using color label direction arrows on the upper control box and the driving chassis.

4) Drive the machine on a slope

- Determine the rated values of machine on up-slope, down-slope and side slope.



Maximum slope rated value, down-slope of platform (gradeability): 45% (24°)



Maximum slope rated value, up-slope of platform: 30% (17 °)



Maximum slope rated value: 25% (14°)

! CAUTION: Slope rated value is

limited by state of ground and tractive force. The term “gradeability” is only used in the down-slope of platform.

- Determine that the arm lever is located between non-steering wheels, and that the arm lever is lowered to below 5° of horizontal plane and is in the shrinkage state. When the turret inclines by 4.5° along the direction of the arm lever, the buzzer gives an alarm, the turret inclination indicating lamp is ON, at which driving function and arm lever function are not limited. The driving speed selector switch can be turned to the slope sign to get larger driving force.

! CAUTION: When the arm lever is

located above 5° of horizontal plane, the driving function will be limited, at which the arm lever shall be lowered to below 5°.

- Determine slope

Measure the slope by using a digital

inclinometer or as per the following steps.

- ✓ Required tools: Carpenters rule, straight wood block (with length of at least 1m), tape measure and other tools.
- ✓ Place the wood block on the slope, place the carpenters rule on the upper limb of the wood block at the end of down-slope, and lift the end of the wood block until it is horizontal.
- ✓ Keep the wood block in the horizontal state, and measure vertical height from the bottom of the wood block to the ground.
- ✓ Height is divided by the length of wood block (stroke), i.e.,

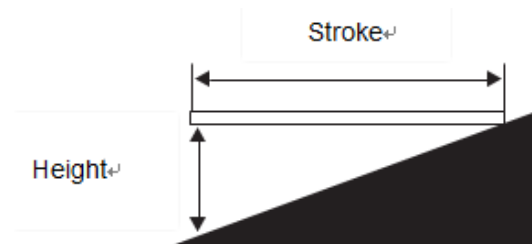

Stroke=3.6m

lifting height=0.3m

$0.3 \div 3.6 = 0.083 = 8.3\%$

! CAUTION: If slope exceeds the

maximum rated value of up-slope, down-slope or side slope, it is necessary to lift or transport the machine up and down along the slope. Please refer to “Transport and Lift” section.

5) Drive enabling

- The driving enabling indicating lamp is ON, and the buzzer gives an alarm. It indicates that the arm lever has gone beyond between two non-steering wheels, driving is disenabled, and the driving function is limited.
- To drive, turn the driving enabling switch to one side, while slowly moving the driving control handle to make it off center.

! Caution that the machine may



move in the direction opposite to the driving and steering control handle, so it is necessary to stop driving, i.e., releasing the handle, followed by loosening the driving enabling switch.

6) Selection of driving speed

- The machine is located at sign on the slope: The engine is switched to high idle speed automatically. To acquire larger driving force, please select the slope sign on the inclined or rough ground.
- The machine is located at the sign on the horizontal plane: For operation of maximum driving speed.

7) Selection of engine idle speed

- Select engine idle speed with the sign on the control panel.
- In the case of failure to stepdown of pedal switch or toggling of handle, the engine will keep idle speed at the lowest revolution.

Turtle sign: Step down the pedal switch to activate low idle speed.

Rabbit sign: Step down the pedal switch, and toggle the handle to activate high idle speed.

9.7 Platform Overload

The platform overload indicating lamp is ON, and the buzzer gives an alarm. Unload from the platform until the indicating lamp is OFF before continuing to operate.

9.8 Non-Level State of the Machine

If the platform is lifted (the arm lever is located above 5° of horizontal plane or extends out of more than 0.6m), the inclination alarm sounds, the non-level indicating lamp of the machine is ON, and the driving function is not activated in two directions. Determine the state of the arm lever on slope, shown as below. Before moving the machine to the solid and horizontal ground, lower the arm lever as per the following steps. Before lowering the arm lever, do not rotate the arm lever.

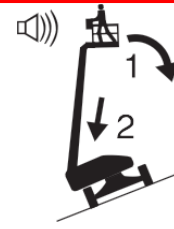

If the inclination alarm sounds on the up-slope of platform:

1. Lower the arm lever.
2. Retract the arm lever.



If the inclination alarm sounds on the down-slope of platform:

1. Retract the arm lever.
2. Lower the arm lever.

9.9 System Fault

The buzzer gives an alarm, and the system fault indicating lamp is ON, indicating that the control system goes wrong. The liquid crystal display will display the corresponding fault code, and the corresponding functions of the machine will be shut down, shown as Table 9-1.

When the system indicating lamp is ON, operate as per the following steps:

- 1) Lower and retract arm lever.
- 2) Move the machine to the storage position, shut down the engine, mark the machine and shut down.
- 3) The machine can be used again only after relevant qualified personnel maintain, troubleshoot and conduct complete inspection.
- 4) System fault code is shown as the following figure:



Operation Manual of Telescopic Boom Mobile Elevating Work Platform

error code	Description	Limit action
1	Controller output power supply 1 open circuit	Main boom upper luffing
2	Controller output power supply 2 open circuit	Main boom upper luffing
3	Controller output power supply 3, 4 open circuit	Main boom upper luffing
4	The CAN bus of the expansion module of the platform electric box is disconnected	Equivalent to the limit logic of all three handle failures
5	The display bus of chassis electric box is disconnected	No data on display
7	Turntable tilt sensor failure	Main boom upper luffing, main boom lower luffing, main boom extended, main boom retracted, turntable rotation, walking
8	Load cell 1 failure	Main boom upper luffing
9	Load cell 2 failure	Main boom upper luffing
10	Load cell 3 failure	Main boom upper luffing
11	Load cell 4 failure	Main boom upper luffing
12	Left handle failure	Main boom upper luffing 、 main boom lower luffing (platform operation), turntable rotation (platform operation)
13	Right handle failure	Main boom upper luffing、 walking、 steering
14	Middle handle failure	Main boom upper luffing, main boom extended, main boom retracted (platform operation)
15	Wire rope disconnect	Main boom upper luffing, main boom lower luffing, main boom extended, main boom retracted、 turntable rotation, walking
16	Main boom angle sensor 1 failure	Main boom upper luffing
17	Main boom angle sensor 2 failure	Main boom upper luffing
18	Main boom angle sensor calibration failure	Main boom upper luffing
19	Boom length sensor 1 failure	Main boom upper luffing、 main boom extended
20	Boom length sensor 2 failure	Main boom upper luffing、 main boom extended
21	Main arm length sensor calibration failure	Main boom upper luffing、 main boom extended
22	Load cell calibration failure	Main boom upper luffing
23	Main boom retraction approach switch 1 failure	Main boom upper luffing
24	Main boom retraction approach switch 2 failure	Main boom upper luffing
25	Main boom extension approach switch 3 failure	Main boom upper luffing
26	Main boom extension approach switch 4 failure	Main boom upper luffing
27	Engine ECU communication failure	Engine start up failure
101	The maximum angle of the boom is limited upward	Main boom upper luffing
102	The minimum angle of the main boom is limited downward	main boom lower luffing
103	Maximum boom extension limit	main boom extended
104	The minimum length of the main boom retracts limit	main boom retracted
105	Turntable tilt	



Operation Manual of Telescopic Boom Mobile Elevating Work Platform

106	The turntable is tilted, the main boom angle is greater than positive 5 degrees, the main boom is up and the main boom is extended	Main boom upper luffing, main boom extended、turntable rotation, walking
107	The turntable is tilted, the extension length of the main boom exceeds 60cm, the main boom is in the upward range, and the main boom extension is limited	Main boom upper luffing, main boom extended、turntable rotation, walking
109	Drive does not enable travel function limit	Walking
110	Platform overload	Limit all actions
111	Long angle sensor bus disconnected	Main boom upper luffing, main boom extended
112	Long angle sensor failure	Main boom upper luffing, main boom extended
113	Low fuel level alarm	
114	Operating range exceeds the safety zone limit	Main boom lower luffing, main boom extended
115	Manual lock reminder	Main boom upper luffing, main boom extended
116	Manually lock the car	Main boom upper luffing, main boom extended、walking
117	GPS and ECU do not match	
118	GPS is removed	Main boom upper luffing, main boom extended
119	The platform load is less than 100kg	Boom luffing down, boom extension, boom retraction, rotary table slewing, fly jib luffing, platform leveling
120	Operation sequence warning	
121	Enable Timeout	
122	Wrong selection of superstructure and chassis	

Table 9-1 System fault codes and limit actions



9.10 Function of Safety

Protection Devices (SPD)

When the safety rod is activated and disengages, the SPD's function will be triggered and all ongoing motions will be stopped. At that time, the blue strobes flash. If the operator presses down the foot switch and attempts to operate the machine, the horn will sound an alarm and no functions will operate. Only when the operator conducts the emergency operation or presses and holds the reset switch, the functions will operate.

The reset switch is on the right of the platform control box, or on the platform box panel depending on the machine models.



Figure-SPD Activated State



Figure-The Strobe Flashes Blue



Figure-Reset Switch 1

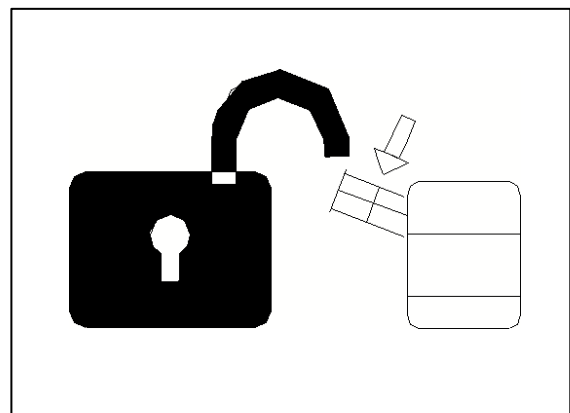

Figure-Reset Switch 2

After the machine is powered on, disengage the safety rod from the proximity switch, and the strobes will flash. Press down the foot switch and the horn will sound immediately. With the foot switch pressed down and being held, press and hold the reset button, operate the joystick, and all functions of the machine will operate normally.

9.11 DPF Instructions

DPF is designed to reduce environmental pollution and harm to human health by filtering particulate matter from engine exhaust gas.

Automatic DPF regeneration: DPF automatically removes particulate matter accumulation in it.

Manual regeneration: If the machine is free of any engine and system fault and alarm, in the



Operation Manual of Telescopic Boom Mobile Elevating Work Platform

stowed position and motionless, and the DPF alarm indicator light of GCU is on, manual regeneration will be required.



Notice: During manual DPF regeneration, there is more exhaust gas, which is hotter. Check the surrounding areas and ensure there is no flammable material and the ventilation is good.



Notice: If a manual regeneration request is ignored, smoke in the DPF may reach the extreme level. The filter will be damaged permanently and shall be replaced by qualified technical maintenance personnel.



Notice: On an engine equipped with the DPF, partial fuel may be mixed with the engine oil during the regeneration process. Therefore, the engine oil may be diluted and the engine oil may be increased. If the engine oil exceeds the upper limit of the level gauge, the engine oil is diluted too much, leading to a fault. In this condition, please replace the engine oil immediately.

If the DPF regeneration interval is 5 hours or shorter, please replace the engine oil.

Notice: Please check the engine and place it at a horizontal position. If it is placed on an inclined surface, the oil capacity cannot be measured.

1) Pull out the Emergency Stop switch and

turn the key switch to ground control.



2) Press the button indicated in the picture to go into the regeneration system screen.



3) Start and idle the engine until coolant temperature exceeds 60°C.



4) Move the DPF regeneration toggle switch and the engine will slow down to 1100r/min. Move the DPF regeneration toggle switch again and the engine will slowly speed up to 2200r/min.

5) Wait for the engine to automatically complete DPF regeneration.

Automatic regeneration inhibition



Danger: Auto-regeneration shall be

prohibited in some working sites.

- 1) Pull out the Emergency Stop switch and turn the key switch to ground control.



- 2) Press the button indicated in the figure to go into the regeneration system screen.



- 3) Press the "Confirm" button to enter the PDF regeneration initiate/inhibit function screen.
- 4) Select the PDF regeneration initiate/inhibit function as appropriate and press the "Confirm" button.



Notice: If automatic DPF regeneration is inhibited over a prolonged period of time and manual DPF regeneration is ignored, smoke in the DPF may reach the extreme level. The filter will be damaged permanently and shall be replaced by qualified technical maintenance personnel.

9.12 Upon Every Use

- 1) Select a solid, horizontal and safe position where it is moisture-proof, high-temperature resistant, open flame resistant, free from corrosive gas and well-ventilated.
- 2) Retract and lower the arm lever to the folding state.
- 3) Close and lock all enclosures and box doors.
- 4) Wipe up dust and oil dirt on the machine body, and keep the machine body clean.
- 5) Turn the turntable to make the arm lever located between non-steering wheels.
- 6) Fix wheels using brake shoes.
- 7) Turn the key switch to the "OFF" position, and unplug the key to avoid unauthorized use.
- 8) When preparing the machine for outdoor storage, protect the exhaust pipe with a waterproof cover against rain and snow ingress into the muffler through it. (Caution: As the exhaust pipe can be hot just after the machine stops, use extreme caution to avoid scalding.)
- 9) During long-term storage
 - Break positive and negative electrodes of battery, discharge fuel completely, and prior to use, clean and conduct overall cleaning and maintenance on the complete machine.
 - When storage period exceeds three months, it is necessary to run for not less than one hour every three months, and conduct cleaning and maintenance.





Chapter 10 Transport Description





10.1 Compliance and Obedience

- 1) The driver shall be responsible for ensuring the machine has been fixed correctly and select proper trailers according to local traffic laws.
- 2) Only personnel with hoisting work aptitude at heights can hoist the machine.
- 3) Transport tractors must stop on the horizontal ground.
- 4) During machine loading, transport vehicles must be fixed to prevent movement.
- 5) Ensure vehicle loads, loading surface, chains, belts, etc. can be sufficient to support the weight of the machine. Please refer to "Nameplate" to understand the weight of the machine.

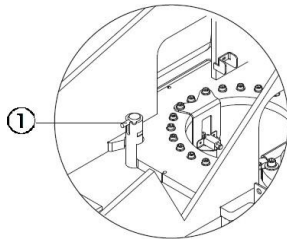

Figure 10-1 Turret rotary lock pin

- 6) Ensure the turret has been fixed using the turret rotary lock prior to transport, as shown in Figure 10-1. Ensure turret is unlocked during operation.
- 7) Do not drive the machine on the slope exceeding the rated value of up-slope, down-slope or slope. Please refer to "Driving on Slope" in "Operating Instructions" section.
- 8) If the slope of the transport vehicle exceeds the maximum slope rated value, it is necessary to use the capstan, and load and unload the machine as per the brake release instructions.
- 9) The vehicle is equipped with a sophisticated weighting system. It is forbidden to place heavy goods on the platform, when the vehicle is transporting, otherwise the weighting system may be damaged.
- 10) The vehicle is equipped with a

sophisticated weighting system. It is forbidden to place heavy goods on the platform, when the vehicle is transporting, otherwise the weighting system may be damaged.

10.2 Brake Release when Using the Capstan

- 1) Cushion wheels with wedges to prevent machine movement.

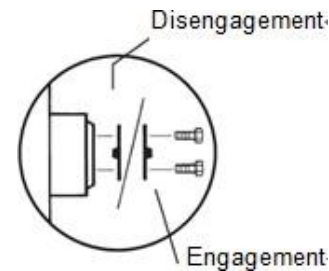

Figure 10-2 Brake release

- 2) Turn over all four driving wheel hub separating covers to release wheel brakes, as shown in Figure 10-2.
- 3) It is necessary to ensure that the capstan cable has been fixed to the fastening location of the driving chassis correctly, and that there are no obstacles in the channel
- 4) Execute the above procedures in the inverted sequence to reengage the brake.



CAUTION: The driving valve shall always be kept in the off state.

10.3 Ensuring Transport Safety

- 1) When transporting the machine every time, it is necessary to lock the turret using the turntable rotary lock pin, as shown in Figure 10-1.
- 2) Prior to transport, turn the key switch to the "OFF" position, followed by taking down the key.
- 3) Conduct the complete inspection of the machine to prevent loosened or unfixed components.



Operation Manual of Telescopic Boom Mobile Elevating Work Platform

- 4) Fix the chassis.
- 5) Ensure that chains or belts have sufficient load strength, and use at least 5 chains. Adjust the rigging to prevent damage to chains, as shown in Figure 10-3.

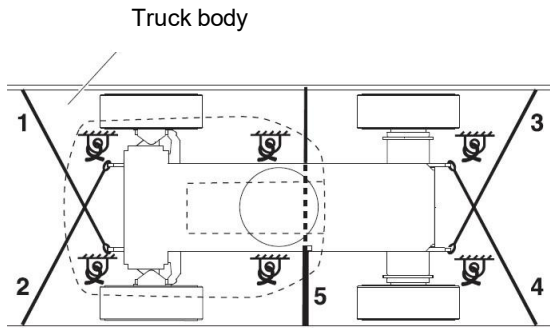

Figure 10-3 Schematic diagram of chassis fixing

- 6) Fix the platform.

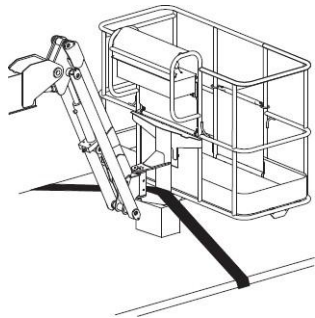

Figure 10-4 Schematic diagram of platform fixing

- 7) Place the cushion block below the platform rotary connection, and do not make the cushion block contact the platform oil cylinder. Make the nylon strap run through the platform support to fix the platform. Do not apply downward force excessively when protecting arm lever components, as shown in Figure 10-4.

10.4 Guidance on Lifting the Machine

- 1) Only qualified jack-up and rigging assembly workers can assemble the rigging and lift the machine.
- 2) Ensure the lifting ability of crane, belts or ropes can be sufficient to support the weight of the machine. Please refer to “Nameplate” to understand the weight of the machine.

- 3) Completely lower and retract arm lever, and disassemble all loosened components on the machine.
- 4) Fix the turntable using the turntable rotary lock. Determine the center of gravity of the machine using data in Figure 10-5.
- 5) Only connect the rigging to the designated lifting point of the machine.
- 6) Adjust the rigging to avoid damage to the machine and keep the machine level.

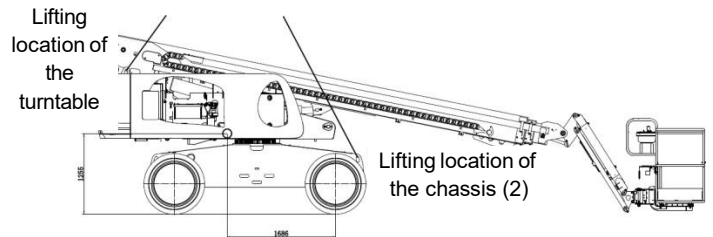

Figure 10-5 Schematic diagram of connection during machine lifting

