

For online reference and to download the manuals for your machines HAULOTTE®, go to :
<https://www.e.technical-information.com>
or, scan the QR Code below :

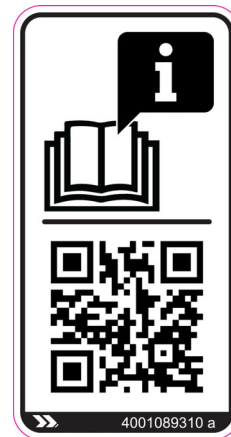

STAR 8 S - STAR 20

Operator's manual

STAR 8 S - STAR 20

4001113000

E 10.21

USA / GB

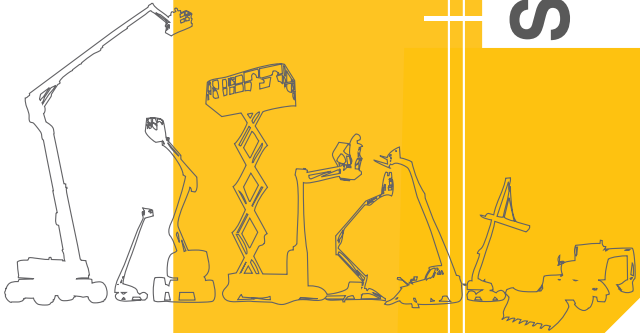

A**FOREWORD**

1 - User responsibility	8
1.1- Owner's responsibility	8
1.2- Employer's responsibility	8
1.3- Trainer's responsibility	8
1.4- Operator's responsibility	9
2 - Safety	10
2.1- Safety instructions	10
2.1.1 - Misuse Hazards	10
2.1.2 - Falling Hazards	10
2.1.3 - Overturning / Tip-over Hazards	12
2.1.4 - Electric Shock Hazards	14
2.1.5 - Explosion / Fire Hazards	15
2.1.6 - Crushing / Collision Hazards	15
2.1.7 - Uncontrolled movement Hazards	16
3 - Safety inquiries	17
4 - Incident notification	17
5 - Compliance	18
5.1- Product modification	18
5.1.1 - Implementing manufacturer safety campaigns	18
5.2- Product specifications	18
5.3- Change of Ownership Notification	19
5.4- Declaration of conformity	20

B**FAMILIARIZATION**

1 - General safety	23
1.1- Intended use	23
1.2- Decal content	24
1.3- Symbols and colors	25
1.4- Level of severity	25
1.5- Symbols legend and definitions	26
2 - Models description	27
3 - Primary machine components	28
3.1- Layout	28
3.2- Maintenance support	30
3.3- Extension deck	31
3.4- Ground control box	32
3.4.1 - Layout	32
3.4.2 - HAULOTTE Activ'Screen	33
3.4.2.1 - LCD screen	34
3.5- Platform control box	38
3.5.1 - Layout	38
4 - Performance Specifications	40
4.1- Technical characteristics	40
4.2- Working area / Range of motion	41
5 - Decals and markings locations	42

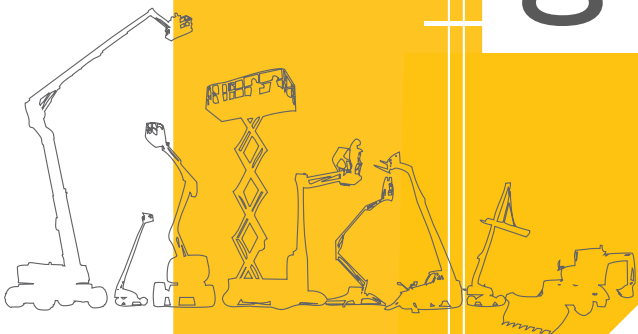
CONTENTS

C**PRE-OPERATION INSPECTION**

1 - Recommendations	53
2 - Working area assessment	53
3 - Inspection and Functional test	54
3.1- Daily inspection	54
4 - Safety functional checks	57
4.1- E-Stop button check	57
4.2- Activation of controls	57
4.3- Fault detector	58
4.3.1- Buzzers test	58
4.4- Overload sensing system	58
4.5- Slope warning device	59
4.6- Travel speed limitation	59
4.7- Electronic variable speed drive	59
4.8- On-board electronics	60
4.9- Machine braking	60
4.10- Wheel motor brake release	60
4.11- Pothole protection system	60
4.12- On-board charger	60

D**OPERATION INSTRUCTIONS**

1 - Operation	61
1.1- Introduction	61
1.2- Operation from the ground control box	61
1.3- Operation from the platform control box	63
2 - Ground control box	64
2.1- To start and stop the machine	64
2.2- Movement control	64
2.3- Additional controls	64
3 - Platform control box	65
3.1- To start and stop the machine	65
3.2- Drive and steer control	65
3.3- Movement control	66
3.4- Additional controls	66
4 - Rescue and emergency procedures	67
4.1- Mast manual lowering procedure	67
5 - Transportation	68
5.1- Putting in transport position	68
5.2- Machine layout — STAR 6 - STAR 13 - STAR 8S - STAR 20	69
5.3- Unloading	69
5.4- Towing	70
5.4.1- Electric brake release	70
5.5- Storage	72
5.6- Loading by ramp	73



CONTENTS

5.7-	Unloading by ramp	73
5.8-	Lifting operation	74
5.8.1-	Lifting with spreaders	74
5.8.1.1-	Safety precautions	74
5.8.1.2-	Necessary equipment	74
5.8.1.3-	Preliminary procedures	75
5.8.1.4-	Procedure for the use of slings - with spreader	75
5.8.2-	Lifting without spreader	77
5.8.2.1-	Safety precautions	77
5.8.2.2-	Necessary equipment	77
5.8.2.3-	Preliminary procedures	77
5.8.2.4-	Procedure for the use of slings - without spreader	78
5.9-	Loading and unloading with forklift	79
6 -	Cold Weather Recommendations	80
6.1-	Environmental conditions	80
6.1.1-	Hydraulic oil	80
7 -	Battery care and maintenance	80
7.1-	Battery recharge	80
7.1.1-	On-board charger	80
7.1.2-	Battery charging	82
7.2-	Battery care and maintenance	84
7.2.1-	Filling batteries	84
7.2.1.1-	Procedure to fill the batteries manually – Option	85
7.2.1.2-	Procedure to fill the batteries automatically – Option	87
7.2.2-	Desulfation charge	87
7.3-	Optimise battery life	88

E

GENERAL SPECIFICATIONS

1 -	Machine dimensions	91
2 -	Major component masses	92
3 -	Acoustics and vibrations	92
4 -	Wheel/Tire assembly	92
4.1-	Technical specifications	92
4.2-	Inspection and maintenance	93
4.2.1-	Procedure of replacement	94



F**MAINTENANCE**

1 - General	97
2 - Maintenance Schedule	98
3 - Inspection program	98
3.1- General program	98
3.2- Daily inspection	99
3.3- Periodic inspection	99
3.4- Reinforced inspection	99
3.5- Major inspection	100
4 - Repairs and adjustments	101

G**OTHER INFORMATION**

1 - Conditions of warranty	103
2 - Subsidiary contact information	103
2.1- California warning	104

H**INTERVENTION REGISTER**

1 - Intervention register	107
--	------------



A - Foreword

You have just purchased a HAULOTTE® product and we would like to thank you for your business.

The aerial work platform is a device for lifting people designed and manufactured with the intent to enable users to access overhead elevated temporary workplaces with the necessary tools and equipment. All other uses or alterations/modifications to the aerial work platform must be approved by HAULOTTE®.

This manual shall be considered a permanent component of the machine and shall be kept with the aerial work platform in the designated Manual Holder, at all times.

Safe operation of this product can only be assured if you follow the operating instructions contained in this manual. To ensure proper and safe use of this equipment, it is strongly recommended that only trained and authorized personnel operate and maintain the aerial work platform.

We would particularly like to draw your attention to 2 essential points :

- Comply with safety instructions.
- Use the equipment within the specified/published performance limits.

With regard to the designation of our equipment, we stress that this is purely for commercial purposes and not to be confused with the technical specifications. Only the specifications in this manual should be used to study the suitability of the equipment for the intended use.

This operator's manual is specific to the HAULOTTE® products listed on the cover page of this manual.



Original language and version :

Manuals in English and French are the original instructions. Manuals in other languages are translations of the original instructions.

The operator's manual does not replace the basic training required for equipment operators. HAULOTTE® has compiled this manual to assist in safe and efficient operation of the products covered in the manual.

The manual must be available to all operators and must be kept in a legible condition. Additional copies can be ordered from HAULOTTE Services®.

Stay Safe and keep working with HAULOTTE® !

For online reference and to download the manuals for your machines HAULOTTE®, go to :

<https://www.e.technical-information.com>

or, scan the QR Code below :

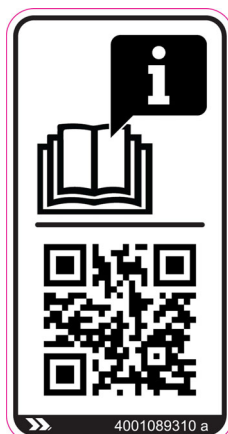

A - Foreword

1 - User responsibility

1.1 - OWNER'S RESPONSIBILITY

The owner (or hirer) has the obligation to :

- To inform operators of the instructions contained in the Operator's Manual.
- Follow local regulations regarding operation of the machine.
- To replace all manuals or decals that are either missing or not legible. Additional copies can be ordered from HAULOTTE Services®.
- To establish a preventive maintenance program in accordance with the manufacturer's recommendations, taking into account the environment and severity of use of the machine.
- To perform periodic inspections in accordance with HAULOTTE® recommendations and local regulations.

All malfunctions and problems identified during the inspection shall be corrected before the aerial work platform is returned to service.

1.2 - EMPLOYER'S RESPONSIBILITY

The employer has the obligation :

- To authorize the operator to use the machine.
- To inform and familiarize the operator with the local regulations.
- Forbid anyone from operating the machine if :
 - Under the influence of drugs, alcohol, etc.
 - Subject to fits, loss of motor skills, dizziness, etc.

1.3 - TRAINER'S RESPONSIBILITY

The trainer must be qualified to provide training to operators in accordance with applicable local regulations. The training must be given in an obstacle-free area until the trainee is considered competent as defined by the training program undertaken.

A - Foreword

1.4 - OPERATOR'S RESPONSIBILITY

The operator has the obligation to :

- Read and understand the contents of this manual and familiarize himself/herself with the decals affixed on the machine.
- To inspect the machine before use according to HAULOTTE®'s recommendations..
- Inform the owner (or hirer) if the manual or any decals are missing or are not legible.
- To inform of any malfunctioning of the machine.

Operators must ensure that the inspections have been carried out by the owner and that they can use the machine for the purpose intended by the manufacturer.

Only authorized and qualified operators may operate HAULOTTE® machines.

All operators must become familiar with and fully understand the emergency controls and be able to operate the machine in an emergency.

The operator has the obligation to stop using the machine in the event of malfunction or safety problems on the machine or in the work area and report the problem immediately to his/her supervisor.

A

B

C

D

E

F

G

H

I

A - Foreword

2 - Safety

2.1 - SAFETY INSTRUCTIONS

2.1.1 - Misuse Hazards

- Do not use the machine for other purposes than to lift people, their tools and equipment to the desired position.
- Do not use the machine as a crane, material lift or elevator. Only use the machine as it was intended.
- Do not attach overhanging loads when raising or lowering the platform.
- Do not tie the platform to an adjacent fixed or mobile structure.
- Do not use/operate the machine when alone. A survey person or immediate Supervisor must be present on the ground in case of emergency.
- Do not use a faulty or poorly maintained machine. Remove defective/damaged machine from service.
- Do not climb onto the compartment covers of the machine.
- Do not replace items critical to machine stability with items of different weight or specification.
- Do not replace factory-installed tires with tires of different specifications or ply rating.
- Do not alter or disable machine components that in any way affect safety and stability.
- Do not disable the safety devices.
- Do not deface, modify or obscure any decals or markings on the aerial work platform.



2.1.2 - Falling Hazards

To enter or exit from the platform :

- The machine must be completely stowed.
- Face the machine to access the entry opening to the platform.
- Keep 3 points of contact (both hands and a foot) on the steps and the guardrail.
- Keep fingers away from moving parts near entry gate.



A - Foreword

Before commencing operation :

- Ensure that guard rails are correctly installed and secured.
- Ensure that gate or sliding bar is in its securely locked position.
- If using a machine that has a swing gate, check that the entry gate closes by itself and gate latches and locks.



- Remove oil or grease from the steps, floor, handrail and the guardrails.
- Clean the floor of the platform (no debris).

When in the platform :

- If local regulations require the wearing of a harness, use only the anchor points provided for this purpose.
- The correct use of the harness requires the lanyard to be connected to an anchorage point designated by the decals. Refer to this decal located on the platform.

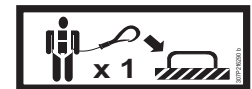

- Hold on securely to the guardrails.
- Always keep your feet firmly on the floor of the platform.
- Do not sit, stand, or climb on the platform guard rails.
- Do not lean on the gate or sliding bar.
- Do not lean over the guard rails or climb over them. Only work in the platform area within the guard rails.
- Do not exit the platform until it is in the completely stowed position.
- Do not use the guardrail as a means of access to climb in or out of the platform.



A- Foreword

2.1.3 - Overturning / Tip-over Hazards

Before positioning and operating the machine :

- Ensure that the surface is capable of supporting the machine weight including the rated capacity. Check the load bearing capacity of the supporting ground.
- Do not exceed the maximum rated capacity that includes the weight of both material and allowed number of occupants. Do not exceed the allowable number of occupants.
- Do not increase the working height (using extensions, ladder, etc.).
- Do not place ladders or scaffolds in the platform or against any part of this machine.
- Place the loads uniformly distributed on the platform floor.
- Do not use the machine in winds exceeding the permissible limit.
- Do not increase the surface area of the platform exposed to wind. This includes adding panels, mesh, banners. Be aware when working with materials with a large surface area. This will add to the wind load on the machine.
- Do not raise the platform or drive with mast raised on inclines exceeding the rated slope.
- Do not drive the machine on slopes or grades exceeding the specified limits.
- Do not replace components critical to stability with components of different weight or specification.
- Do not use the machine with material or objects hanging from the guardrails or the platform.
- Do not pull or push towards any object outside of the platform. Do not exceed the maximum allowable side force stated in the performance specifications.
- Do not use the machine to support any external structure.
- Do not use the machine to tow other machines or to drag materials.



A- Foreword

Using a machine on a slope



Do not drive the machine on slopes with gradients exceeding the authorised transversal and lateral limits for the machine.  Section B 4.1 - Technical specifications.



While machine is on a slope, take extra precautions :

- to make sure that the machine does not over steer.
- to make sure there is NO loss of traction causing machine movement.

WIND : The aerial work platform can operate up to a maximum wind speed as indicated in the specifications. To identify the local wind speed, use the Beaufort scale below, use a wind gauge or an anemometer.

N.B.-:-THE BEAUFORT SCALE OF WIND FORCE IS ACCEPTED INTERNATIONALLY AND IS USED WHEN COMMUNICATING WEATHER CONDITIONS. A WIND SPEED RANGE AT 10 M (32 FT 9 IN) ABOVE FLAT, CLEAR LAND IS ASSOCIATED WITH EACH DEGREE.

Beaufort scale

Force	Meteorological description	Observed effects	m/s	km/h	mph
0	Calm	Smoke rises vertically.	0 - 0,2	0 - 1	0 - 0,62
1	Very light breeze	Smoke indicates the wind direction.	0,3 - 1,5	1 - 5	0,62 - 3,11
2	Light breeze	Wind felt on the face. Leaves rustle. Weather vanes turn.	1,6 - 3,3	6 - 11	3,72 - 6,84
3	Slight breeze	Leaves and small twigs in constant motion. Flags move slightly.	3,4 - 5,4	12 - 19	7,46 - 11,8
4	Nice breeze	Raised dust and loose papers. Small branches are moved.	5,5 - 7,9	20 - 28	12,43 - 17,4
5	Nice breeze	Small trees in leaf to sway. Crested wavelets form on inland waterways.	8,0 - 10,7	29 - 38	18,02 - 23,6
6	Cool wind	Large branches in motion. Power lines and chimneys 'sing'. Umbrellas used with difficulty.	10,8 - 13,8	39 - 49	24,23 - 30,45
7	Near gale	Whole trees in motion. Inconvenience felt when walking against wind.	13,9 - 17,1	50 - 61	31 - 37,9
8	Gale	Some branches break. Generally we cannot walk against the wind.	17,2 - 20,7	62 - 74	38,53 - 45,98
9	Strong gale	The wind causes slight damage to buildings. Tiles and chimney stacks are blown off.	20,8 - 24,4	75 - 88	46,60 - 54,68

A- Foreword

2.1.4 - Electric Shock Hazards

The machine is not electrically insulated and does not provide protection from contact or proximity to electrically charged conductors.

Always position the lift at a safe distance from electrically charged conductors to ensure that no part of the machine is within an unsafe area.

Respect the local rules and the minimum safety distance from power lines.

Minimum safe approach distances

Electric voltage	Minimum safety distance	
	Mètre	Feet
0 - 300 V	Avoid contact	
300 V - 50 kV	3	10
50 - 200 kV	5	15
200 - 350 kV	6	20
350 - 500 kV	8	25
500 - 750 kV	11	35
750 - 1000 kV	14	45

N.B.-:USE THIS TABLE EXCEPT WHERE LOCAL REGULATIONS INDICATE OTHERWISE.

- Do not operate the machine when close to live power lines, consider the movement of the machine and the sway of the electric power lines particularly in windy conditions.
- Do not operate the machine during lightning, thunderstorms, snow/ice or any weather condition that could compromise operator safety.
- Do not use the machine as a ground for welding.
- Do not weld on the machine without first disconnecting the battery terminals.
- Always disconnect ground cable first.
- The machine must not be used while charging the batteries.
- When using the AC power supply, ensure it is protected with a circuit breaker and residual current device.



Keep away from the machine if it contacts energized power lines. Personnel on the ground or in the platform must not touch or operate the machine until energized power lines are shut off.

A - Foreword

2.1.5 - Explosion / Fire Hazards

Always wear protective clothing and eye wear when working with batteries and power sources/systems.

N.B.-:ACID IS NEUTRALIZED WITH SODIUM BICARBONATE AND WATER.

- Do not work on or operate a machine in an explosive or flammable atmosphere / environment.
- Do not touch hot components.
- Do not bridge the battery terminals with metallic objects.
- Do not service the battery in proximity of spark, open flame, lit cigarettes.
- ALWAYS avoid contact with battery acid. Battery acid causes serious burns and should be kept away from skin or eyes. If contact occurs, flush with water and consult a physician immediately.



2.1.6 - Crushing / Collision Hazards

When in the platform :

- Check the work area for overhead clearance, for any obstacles besides and below the platform when raising/lowering the platform and or before driving.
- During movement, keep all the parts of the body inside the platform. Hold onto the guardrails on the opposite side to any surrounding structures. Take care to avoid trapping hands whilst holding the guardrails.

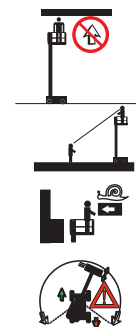

- Always cordon off the area around the base of the machine to keep personnel and other equipment away from the machine while in use.
- Warn personnel not to work, stand, or walk under a raised boom/platform.
- Do not drive in reverse direction (opposite the field of vision).
- Always ensure that the chassis is never kept any closer than 1 m (3 ft 3 in) to holes, bumps, slopes, obstructions, debris and ground coverings that may hide holes and other dangers.
- Keep non-operating personnel at least 5 m (16 ft 5 in) away from the machine when driving.
- Be aware of driving direction.
 - Check the driving direction with the help of the red or green arrow on the chassis relative to the red and green arrows on the platform control box.
 - Also note that when changing the driving direction (Forward <> Reverse) the joysticks or switches must return to the neutral position before reversing the drive direction and for movement to occur.

A- Foreword

- When driving, position the platform so as to provide the best possible visibility and to avoid any blind spots.
- Hold on securely to the guardrails.
- Personal fall protection equipment (PFPE) :
 - Occupants must wear a safety harness, personal protective equipment and comply with the applicable national regulations. Attach the safety harness lanyard to the designated anchorage points provided for this purpose on the work platform.
 - Operators must comply with the safety standards of the job site and the employer, as well as the applicable state regulations relating to the use of personal protective equipment.
 - All personal fall protection equipment (PFPE) must comply with current regulations, must be inspected and used in accordance with the manufacturer's instructions.
- Avoid contact with fixed or mobile obstacles (other machines).
- Other machines (crane, aerial work platform, etc.) operating in the work area increase the risk of crushing or collision. Restrict the operation of machines moving within the aerial work platform work area.
- Take into consideration the stopping distance, reduced visibility and blind spots of the machine.
- Limit travel speed to suit the ground surface condition, slope (incline), and people in the vicinity.

2.1.7 - Uncontrolled movement Hazards

Never use a damaged or malfunctioning machine.

Always respect the following rules :

- Maintain clearance from high voltage lines.
- Maintain clearance from generators, radar, electromagnetic fields.
- Never expose the batteries or electrical components to water (high pressure washer, rain).



While machine is on a slope, take extra precautions :

- **to make sure that the machine does not over steer.**
- **to make sure there is NO loss of traction causing machine movement.**

A - Foreword

3 - Safety inquiries

Inquiries relating to design criteria/specifications of a product, standards compliance, or overall machine safety should be sent to the HAULOTTE® PRODUCT SAFETY department.

Each inquiry or request should include all relevant information; including contact name, telephone number, mailing address, email address, plus the machine model and serial number.

The HAULOTTE® Product Safety department will evaluate each request/inquiry and will provide a written response.

4 - Incident notification

Notify HAULOTTE® immediately when a HAULOTTE® product has been involved in an incident/accident leading to personal injury or death, or when there is a major property damage.

<p>HAULOTTE Group - EUROPE Product Safety Department</p> <p>Address : Rue Emile Zola - 42420 Lorette - France</p> <p>Tel : +33 (0)4 77 29 24 24</p> <p>Email : productsafety.europe@haulotte.com</p>	<p>HAULOTTE Group - Australia, India and Asia Product Safety Department</p> <p>Address : No.26 Changi North Way - Singapore 498812 - Singapore</p> <p>Tel : +65 6546 0123</p> <p>Email : productsafety.apac@haulotte.com</p>	<p>HAULOTTE Group - North & South America Product Safety Department</p> <p>Address : 3409 Chandler Creek Rd. - Virginia Beach, VA 23453 - United States</p> <p>Tel : +1 757 689 2146</p> <p>Email : productsafety.americas@haulotte.com</p>
--	--	---

Connect to our website : www.haulotte.com



A - Foreword

5 - Compliance

5.1 - PRODUCT MODIFICATION

It is strictly forbidden to modify a HAULOTTE® product. Any modification may violate Haulotte design parameters, local regulations and industry standards.

All modifications must be submitted in writing (form) and approved by the manufacturer.

Do not hesitate to contact HAULOTTE Services®, should you have any questions relating to the issued bulletin(s) or with questions on the policy itself.

5.1.1 - Implementing manufacturer safety campaigns

It is essential to implement the safety campaigns issued by the manufacturer. All of these campaigns are accessible on our website.

Connect to our website : www.haulotte.com



Never place a machine on the market without completing all the Safety Campaigns.

5.2 - PRODUCT SPECIFICATIONS

HAULOTTE® cannot be held liable for any changes to the technical characteristics/specifications contained in this manual. HAULOTTE® has a continuous improvement policy in place for its product range. Given this policy, the Company reserves the right to modify products technical characteristics / specifications without notice.

Certain options/accessories can modify the machine's operating characteristics and its' associated safety. If your machine was originally delivered with options fitted, replacing a safety component associated with a particular option does not require any particular precaution other than those associated with the installation itself (static test).

Otherwise, it is essential to follow the manufacturer's recommendations as stated below :

- Installation by authorised HAULOTTE® personnel only.
- Update the manufacturer's identification plate.
- Have stability tests carried out by a certified agency/competent person.
- Ensure decals are updated.

A - Foreword

5.3 - CHANGE OF OWNERSHIP NOTIFICATION

It is important and necessary to keep HAULOTTE Services® updated with current ownership of the machine. This way, HAULOTTE® will be able to provide the necessary support for the product. If you have sold or transferred this machine(s); it is your responsibility to notify HAULOTTE Services®. It is not required to include Lessees/Renters of Leased/Rented machines on this form.

Connect to our website : www.haulotte.com



A

B

C

D

E

F

G

H

I

A - Foreword

5.4 - DECLARATION OF CONFORMITY



CE Declarations of Conformity only apply to machines that are certified for the European market.

Declaration of conformity - Electric platforms



**DECLARATION CE DE CONFORMITE
(EC DECLARATION OF CONFORMITY)**



<p>Fabricant et personne autorisée à constituer le dossier technique : <i>(Manufacturer and the person authorised to compile the technical file.)</i></p> <p>HAULOTTE GROUP</p> <p>Adresse du site de production <i>(Address of the Division)</i></p> <p>en conformité avec le modèle type <i>(In compliance with the Model Type)</i></p> <p>Nom commercial <i>(Commercial name)</i></p> <p>Numéro de série <i>(Serial number)</i></p> <p>Organisme notifié <i>(Notified body)</i></p> <p>Numéro de certificat <i>(Certificate number)</i></p> <p>Charge maximale d'utilisation <i>(Rated capacity)</i></p>	<p>Compliance & Regulation Director HAULOTTE GROUP S.A. RUE EMILE ZOLA</p> <p>42420 LORETTE FRANCE</p> <p>Nacelle élévatrice de personnel (Mobile Elevating Work Platform)</p> <p>Modèle type de la machine concernée <i>(Type model of the concerned machine)</i></p> <p>Nom commercial de la machine concernée <i>(Commercial name of the concerned machine)</i></p> <p>Numéro de série de la machine <i>(Serial number of the machine)</i></p> <p>Nom et adresse de l'organisme notifié <i>(Name and address of notified body)</i></p> <p>Numéro de certificat du type de machine <i>(Certificate number of the type of machine)</i></p> <p>Charge maximale d'utilisation de la machine concernée <i>(Rated capacity of the concerned machine)</i></p>
--	--

**Nous déclarons que cette machine est conforme aux dispositions des Directives suivantes
(We hereby declare that this machine conforms with all the relevant provisions of the Directives listed below)**

<p>Directive CE Machine <i>(EC Machinery Directive)</i></p> <p>Se conforme aux principales exigences de la norme harmonisée <i>(This machine also fulfils the principles of the harmonised standard)</i></p> <p>Directive CE concernant la compatibilité électromagnétique <i>(EC Directive on electromagnetic compatibility)</i></p> <p>Directive CE RED concernant les équipements radioélectriques (si machine équipée) <i>(RED EC Directive on radio electrical equipment (if machine equipped))</i></p> <p>Cette déclaration porte exclusivement sur la machine dans l'état où elle a été placée sur le marché <i>(This declaration relates exclusively to the machinery in the state in which it was placed on the market)</i></p> <p>Toute modification de la machine décrite ci-dessus a pour effet d'invalider cette déclaration <i>(Any modification to the above described machine violates the validity of this declaration)</i></p>	<p>2006/42/CE</p> <p>EN280:2013 + A1:2015</p> <p>2014/30/EU</p> <p>2014/53/EU</p> <p>Lieu <i>(Place)</i></p> <p>Date <i>(Date)</i></p>
--	--

Nom et signature du Directeur du site de production
(Name and signature of the Division Director)

Lieu *(Place)*

Date *(Date)*

haulotte.com

A- Foreword



UKCA Declarations of Conformity only apply to machines that are certified for England, Wales and Scotland.

Declaration of conformity - Electric platforms

Haulotte

UKCA DECLARATION OF CONFORMITY

Manufacturer and the person authorised to compile the technical file:

HAULOTTE GROUP

France



Nathalie Reynolds
 General Manager UK and Ireland
 Haulotte UK Ltd

Unit 1 Gravelly Way, Four Ashes
Wolverhampton, West Midlands WV10 7GW
ENGLAND

Mobile Elevating Work Platform

In compliance with the Model Type

Commercial name

Serial number

Approved body

Certificate number

Rated Capacity

Model Type of the concerned machine

Commercial name of the concerned machine

Serial number of the machine

Rated capacity of the concerned machine

We hereby declare that this machine conforms with all the relevant provisions of the Regulations listed below

Supply of Machinery (safety)	2008
This machine also fulfils the principles of the designed standards	BS EN280 : 2013 + A1 : 2015
Electromagnetic compatibility	2016
Radio equipment (if machinery equipped)	2017

This declaration relates exclusively to the machinery in the state in which it was placed on the market

Any modification to the above described machine violates the validity of this declaration

Name and signature division director

Date and place

haulotte.com

B - Familiarization

1 - General safety

1.1 - INTENDED USE

Do not operate the product in the following situations :

- On soft, unstable or cluttered ground.
- With wind blowing faster than the permissible limit :
 - Check the allowable wind speed specified in the performance specifications tabulation.
 - Consult the Beaufort scale.
- Close to power lines. Keep a safe distance.
- If the machine is stored at a temperature out of range - 20°C / + 50°C (- 4°F / + 122°F).
- In an explosive atmosphere / environment.
- During storms.
- In the presence of strong electromagnetic fields.

N.B.-:USE THE MACHINE UNDER "NORMAL" CLIMATIC CONDITIONS. IF YOU NEED TO USE THE MACHINE IN CLIMATIC CONDITIONS LIKELY TO CAUSE DETERIORATION (EXTREME : HUMIDITY, TEMPERATURES, SALINITY, CORROSIVENESS, ATMOSPHERIC PRESSURE), CONTACT HAULOTTE SERVICES®. REDUCE INTERVALS BETWEEN SERVICING.

N.B.-:WHILE THE MACHINE IS NOT IN USE, CARE MUST BE TAKEN TO BRING THE MACHINE TO THE FULLY STOWED POSITION. ENSURE THAT THE MACHINE IS LOCKED IN A SECURE LOCATION, AND THE CONTROL KEY IS REMOVED TO PREVENT UNAUTHORISED USE OF THE MACHINE.

B- Familiarization

1.2 - DECAL CONTENT

Decals are provided to alert the user of hazards inherent with the Aerial Work Platforms.

Decals provide the following information :

- The level of severity.
- The specific hazard.
- A method to avoid, suppress or reduce the hazard.
- Descriptive text (where required).

Familiarize yourself with the decals and the hazard severity levels.

Decals must be kept in good legible condition.

Familiarize yourself with the decals and their respective color codes.

Additional decals can be ordered from HAULOTTE Services®.

CE, UKCA and AS standards



ANSI and CSA standards









Marking	Description
1	Hazard symbol
2	Level of severity
3	Avoidance symbol pictorial
4	Avoidance text

B- Familiarization











1.3 - SYMBOLS AND COLORS

Symbols and colors are used to alert the operator of safety precautions and/or to highlight important safety information.

The following safety symbols are used throughout this manual to indicate specific hazards and the hazard severity level when operating or maintaining the Aerial Work Platform.

Symbol	Description
	Danger : Risk of injury or death
	Caution : Risk of material damage
	Prohibited action
	Reminder to use good practice or follow pre-operation checks
	Cross-reference to another part of the manual
	Cross-reference to another manual
	Cross-reference to repair (contact HAULOTTE Services®)
N.B. :	Additional technical information

1.4 - LEVEL OF SEVERITY



































Color	Title	Description
	 DANGER	Danger : Indicates a hazardous situation which if not avoided, WILL result in death or serious injury.
	 WARNING	Warning : Indicates a hazardous situation which if not avoided, COULD result in death or serious injury.
	 CAUTION	Caution : Failure to comply could result in minor or moderate injury.
	 NOTICE	Notice : Indicates recommended practices if not followed, may result in a malfunction or damage the machine or its components.
	 PROCEDURE	Procedure : Indicates a maintenance operation.

B- Familiarization

1.5 - SYMBOLS LEGEND AND DEFINITIONS

Symbols are used throughout this manual to depict hazards, avoidance measures and indicate when information is required.

Refer to the following table to familiarize yourself with these symbols.

Symbol	Description	Symbol	Description	Symbol	Description
	Body crushing hazard		Foot crushing hazard		High pressure fluid ejection hazard
			Hand crushing hazard		Entanglement hazard
			Health/safety hazards related to chemicals		Health-damaging effects from hot work environment
	Electrical contact or lightning strike		Burns and scalds from contact with flames, explosion or radiation from heat sources		Injury from Electric arcs - Energy supply disconnecting devices - Batteries fire, emissions, etc
	Risk of operator(s) falling		Tip over due to excessive loading / wind load and excessive ground slope		Relate and coordinate directional arrows on the chassis with those on the control box
	Do not put foot in this area		Do not put your hand in this area		Keep away from product working area
	Never expose batteries and electrical component to high pressure washer		Ensure entry drop rail is down		
	Flames prohibited		Maintain safe clearance from high voltage electrically charged conductors as described in manual - Do not use in thunderstorms		Overload
	Refer to operator manual		Safety belt		Use appropriate lanyard attached to dedicated anchor point.
	Wheel pressure		Enable switch		Use safety prop before attempting any maintenance work
	Tow point		Tie down point		Lift point
	Keep away from hot surfaces		Wear protective equipment		

B - Familiarization

2 - Models description

Models	Regulations						
	CE	UKCA	ANSI	CSA	EAC	AS	JIS
STAR 8S	✓	✓	✗	✗	✓	✓	✓
STAR 20	✗	✗	✓	✓	✗	✗	✗

Legend

✓	Available
✗	Not available

B - Familiarization

3 - Primary machine components

3.1 - LAYOUT

STAR 8S - STAR 20 with platform extension

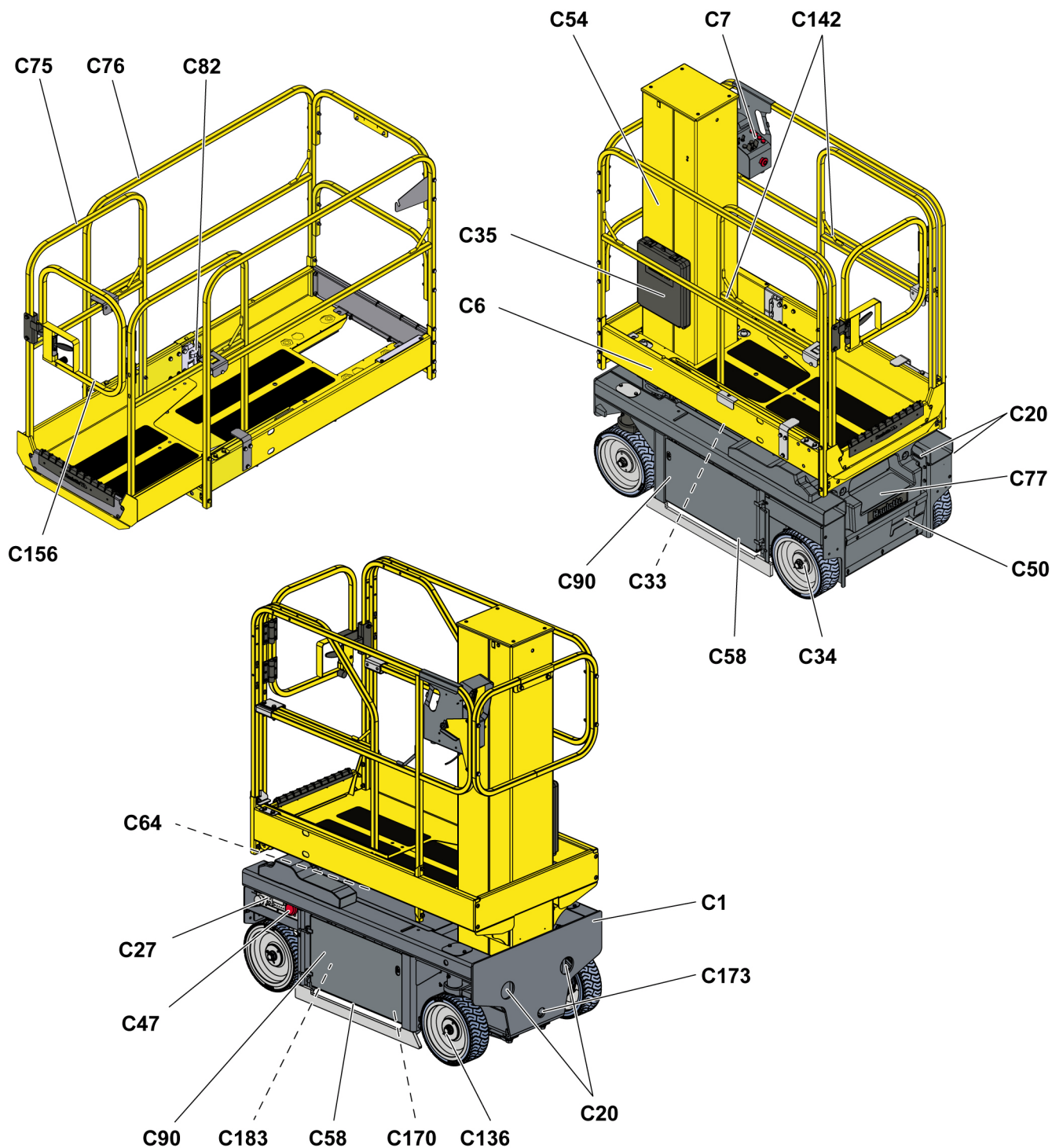

B- Familiarization

Marking	Description	Marking	Description
C1	Chassis	C64	Tilt sensor
C6	Platform	C75	Extension deck
C7	Platform control box	C76	Guardrail
C20	Tie-down (and/or forklift loading)	C77	Platform access step
C27	Ground control box + Universal plug	C82	Unlock pedal extension deck
C33	Counterweight	C90	Battery bay (block)
C34	Rear drive wheels	C136	Front steer wheels
C35	Document holder	C142	Lanyard attachment points
C47	Battery isolation switch	C156	Platform entry
C50	Battery charger socket	C170	Brake release switch
C54	Telescopic mast	C173	Emergency lowering valve
C58	Pothole protection	C183	Hydraulic oil level

Universal plug



B- Familiarization

3.2 - MAINTENANCE SUPPORT

The maintenance stand must be in place before any maintenance operation is begun.

Placing the machine in maintenance configuration :

- Raise the telescoping mast upto 2 m (6 ft 7 in).
- Insert the safety prop (1) in the hole to lock the mast.



Ensure that the safety prop is properly positioned.

- Push the E-stop button to cut off the electricity supply.

Putting in use position :

- To put back the machine into its normal operation, reverse the steps used above.



B- Familiarization

3.3 - EXTENSION DECK

N.B.:-DO NOT LOAD THE EXTENSION DECK, FOR EASE OF MANOEUVRING.

Ensure that gate or sliding bar is in it's proper closed position.

Perform these operations on flat, horizontal ground.

- Press the pedal (1) to release the extension deck lock pin.

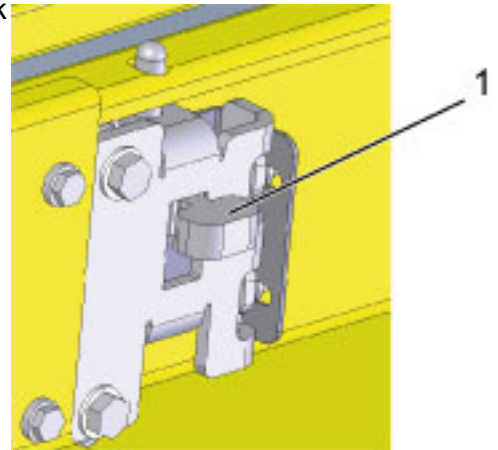

- With pedal (1) pressed, push the extension deck guard rails (2) to the extended position.

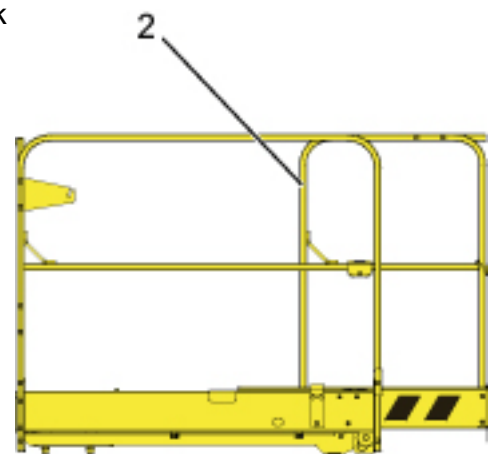

Make sure that the extension deck is in locked position.

To retract the extension deck, press pedal and pull the extension deck rails inwards to the locked position. Release the pedal.

B- Familiarization

3.4 - GROUND CONTROL BOX

3.4.1 - Layout

General view

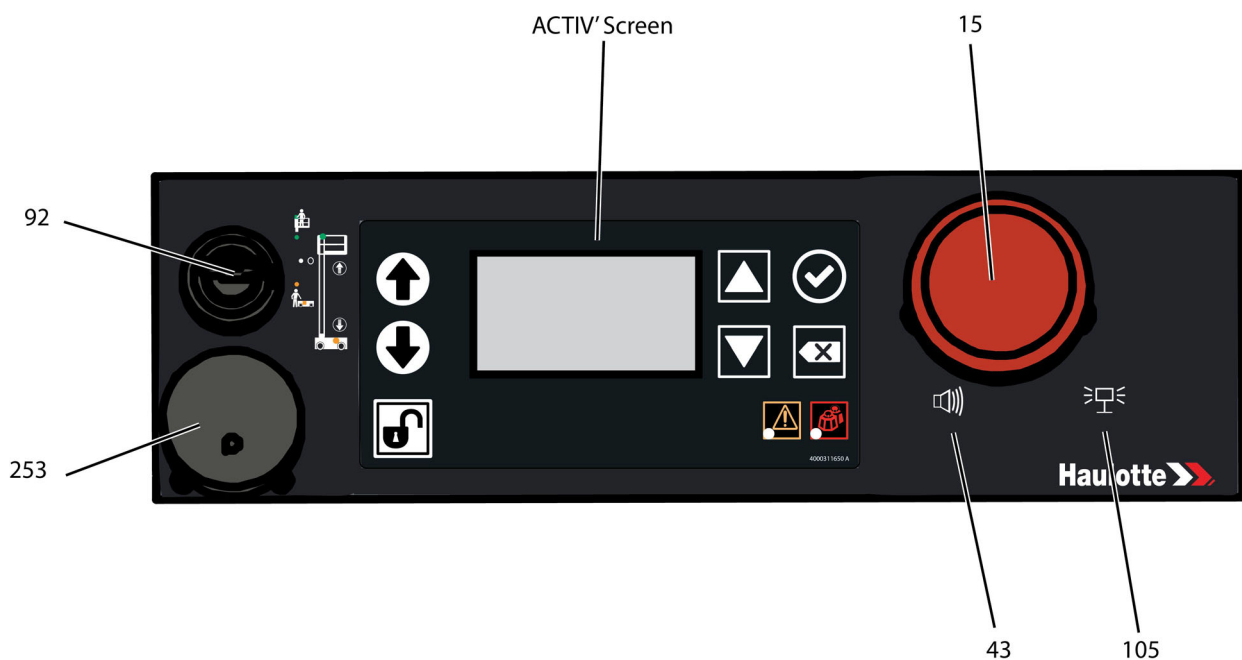

Controls and indicators

Marking	Name	Description	Function
15	SB801	E-stop button	Pulled out : Ground control box energized
			Pushed in : De-energizes control system
43	HA907	Horn button ¹	Horn
92	SA901	Control box activation key switch	Move upwards : Platform control box energized
			Center : De-energizes control system
			Move downwards : Ground control box energized
105	EL901	Beacon light ²	Move to the right : Activated
			Move to the left : Off
253	CN03	Diagnostic tool socket	Connection to the diagnostic tool (HaulotteDiag)

1. For machines fitted with

2. For machines fitted with

B- Familiarization

3.4.2 - HAULOTTE Activ'Screen

Upon starting and during operation of the machine, the LCD screen "Activ'Screen" located on the ground control box displays in real time the machine operating status.

HAULOTTE Activ'Screen

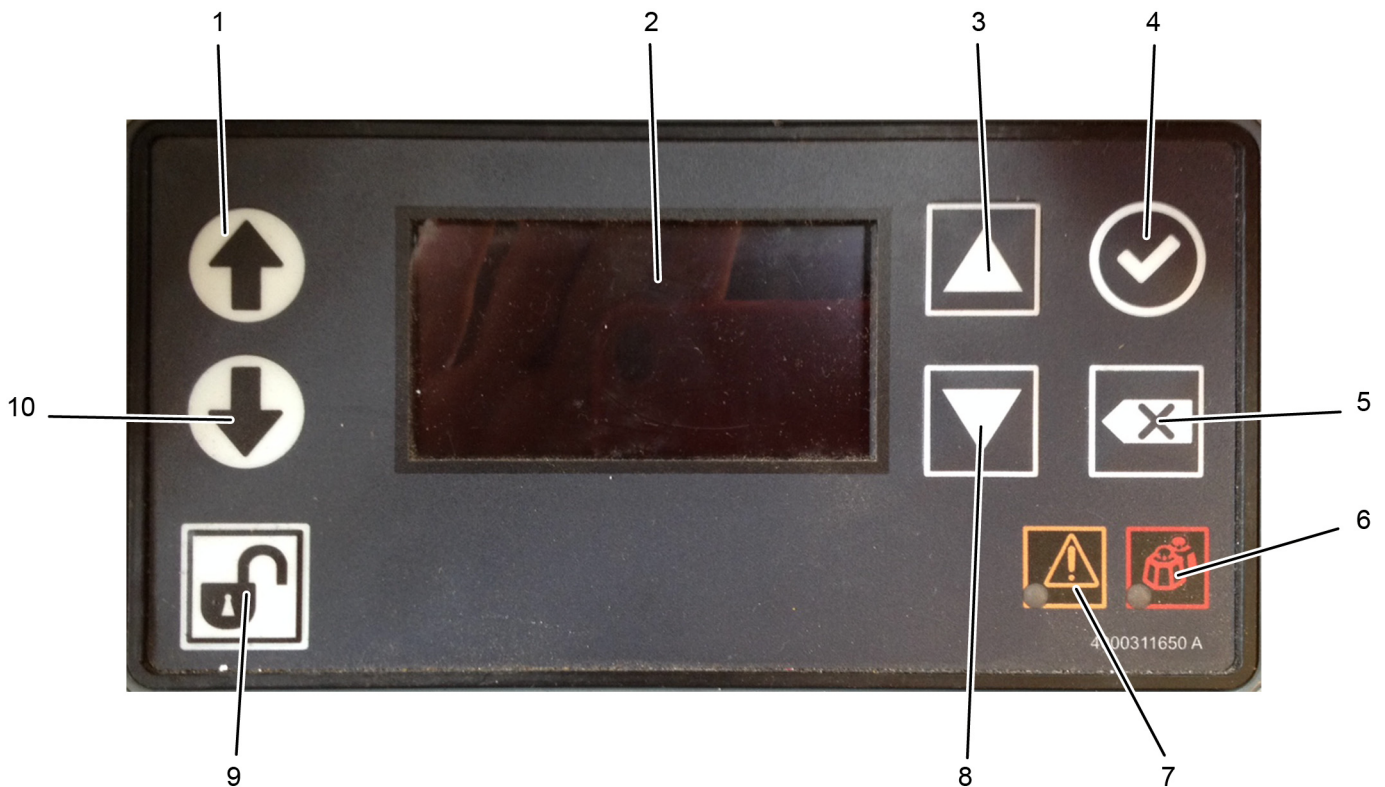

Controls and indicators

Marking	Description	Function
1	Mast control	Mast lifting
2	LCD screen	Display status of operation of the machine
3	Navigation button	Navigation of menu to select function - Scroll up
4	Confirmation button	Confirmation of the selected function
5	Cancellation button	Go back
6	Platform overload indicator	Overload indicator
7	Machine fault indicator	Constantly lit in the event of an operation malfunction
8	Navigation button	Navigation of menu to select function - Scroll down
9	Enable Switch	Press in and hold : Enable switch
10	Mast control	Mast retraction

B- Familiarization

3.4.2.1 - LCD screen

At startup

At startup with the ground or platform controls selected; system initiates a self check :

- Bar gets filled up.

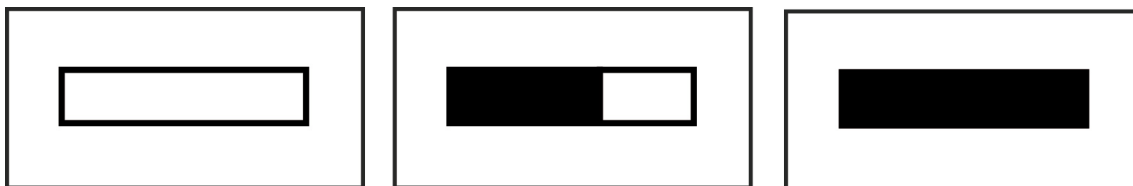

- Home screen comes on with status icon of the machine - okay to proceed functioning the controls.

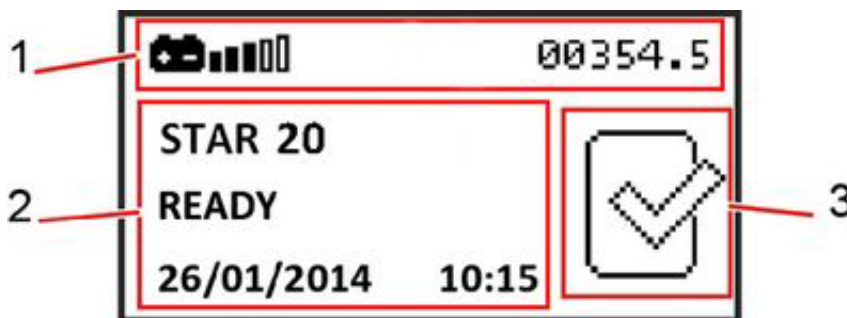

Symbol	Description
1	Information icons
2	Information text
3	Status icon of the machine

Symbol	Description
	Battery status
	Maintenance use
	Fault / alarms
	Hour meter

B- Familiarization

- Pressing either one of the buttons  , the following screen shot will be displayed :

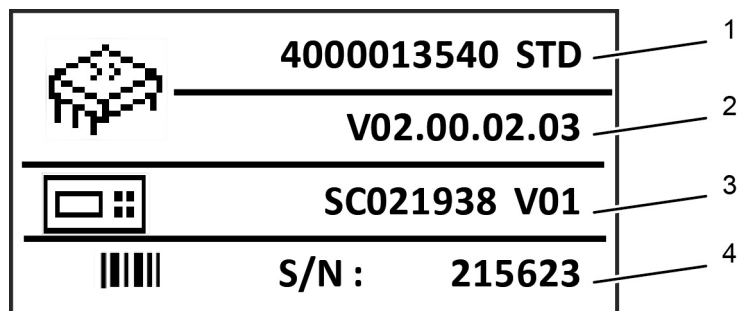

Symbol	Description
1	Software part number
2	Software version + Screen software version + Screen version
3	Screen identification + Screen software version
4	Machine serial number displayed

- After again pressing either one of the buttons  , the following screen shot will be displayed
- Access code screen comes on - refer to maintenance manual for entering the access code



- Validation by pressing on is active only if access code is known and entered - refer to maintenance manual for the procedure for the different level code usage

B- Familiarization

Alarm status :

Alarm status displayed as applicable - samples shown below

Tilt :



Overload :



Low battery :



Recharge the batteries :



B- Familiarization

Fully recharge the batteries.

Low battery water level :



Low water tank level :



Present fault :



A

B

C

D

E

F

G

H

I

B - Familiarization

3.5 - PLATFORM CONTROL BOX

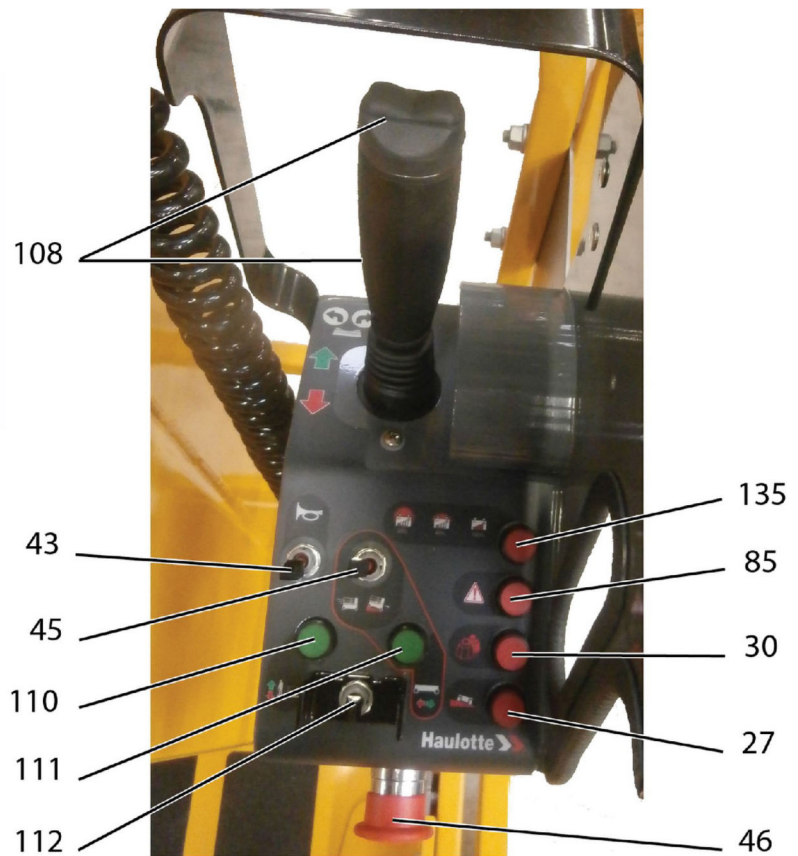

3.5.1 - Layout

General view



B- Familiarization

Controls and indicators

Marking	Name	Description	Function
27	HL800	Tilt indicator	Machine on excessive slope
30	HL802	Overload indicator	Overload indicator
43	SA907	Horn button	Move upwards and hold to activate horn
45	SA110	Drive speed selector	 Move to the left : High-speed drive selection (for long distance)
			 Move to the right : Low-speed drive selection (for short distance, final approach and slopes)
46	SB802	E-stop button	Pulled out : Platform control box power supply energized
			Pushed in : De-energizes control system
85	HL903	Fault indicator	Faulty or tilting machine
108	SM901	Movement joystick	Move forward : Forward drive or mast lifting Move backwards : Reverse drive or mast descent
		Front axle steering selector	Press right side of thumb button : Right-hand steering Press left side of thumb button : Left-hand steering
110	HL420	Mast lifting / descent selection indicator	On : Mast lifting / descent selection activated
			Off : Mast extension / retraction movement is not selected
111	HL100	Driving selection indicator	On : Driving function activated
			Off : Driving movement is not selected
112	SA908	2-position selector	Move to the left : Mast lifting / descent
			Move to the right : Drive and steer movements
123	SM901	Enable Switch	Press in : Associated command is validated
			Release : Associated command movement is halted
135	HL904	Battery charging indicator	Battery charge status

A

B

C

D

E

F

G

H

I

B - Familiarization

4 - Performance Specifications

4.1 - TECHNICAL CHARACTERISTICS

Use the table to select the right Haulotte machine for the job.



Do not replace parts that are essential to the stability of the machine, such as batteries or tyres, with parts that have a different weight or different specifications. The stability of the machine could be affected.

CE, UKCA, AS, EAC, CSA and ANSI A92.20 standards

Machine	STAR 8S - STAR 20 with platform extension	
Characteristics - Dimensions	SI	Imp.
Maximum working height	7,95 m	25 ft 6 in
Maximum platform height	5,95 m	19 ft 6 in
Total weight	1 150 kg	2,535 lbs
Number of extensions	1	
Extension deck length	0,40 m	1 ft 4 in
Maximum extension deck capacity	120 kg	265 lbs
Maximum platform capacity	200 kg	440 lbs
Maximum number of occupants	1	
Maximum wind speed	Indoor use : 0 km/h (0 m/s)	Indoor use : 0 mph (0 ft/s)
Manual force	200 N	45 lbf
Gradeability	25 %	
Maximum longitudinal rated slope	3°	
Maximum side rated slope	1,5°	
Maximum load on wheel	753 kg	1,660 lbs
Maximum ground pressure of wheel on paved ground	14 daN/cm ²	
Drive speed :		
• Folded machine maximum speed	4,5 km/h	2.8 mph
• Unfolded machine maximum speed	0,5 km/h	0.3 mph
Maximum freewheel speed during towed operation	4,5 km/h	2.8 mph
Outside turning radius	1,575 m	5 ft 2 in
Inside turning radius	0,35 m	1 ft 2 in
Energy storage		
Type of battery	Traction	
Standard	Option	Battery weight
X		29 kg(63 lb)
	X	32 kg(71 lb)
	X	30 kg(66 lb)
		System voltage
		24 V
		24 V
		24 V
		Capacity
		185Ah (C5)
		170Ah (C5)
		182Ah (C5)
Hydraulic tank capacity	9 l	2 gal US

B - Familiarization

4.2 - WORKING AREA / RANGE OF MOTION

STAR 8S - STAR 20 with platform extension

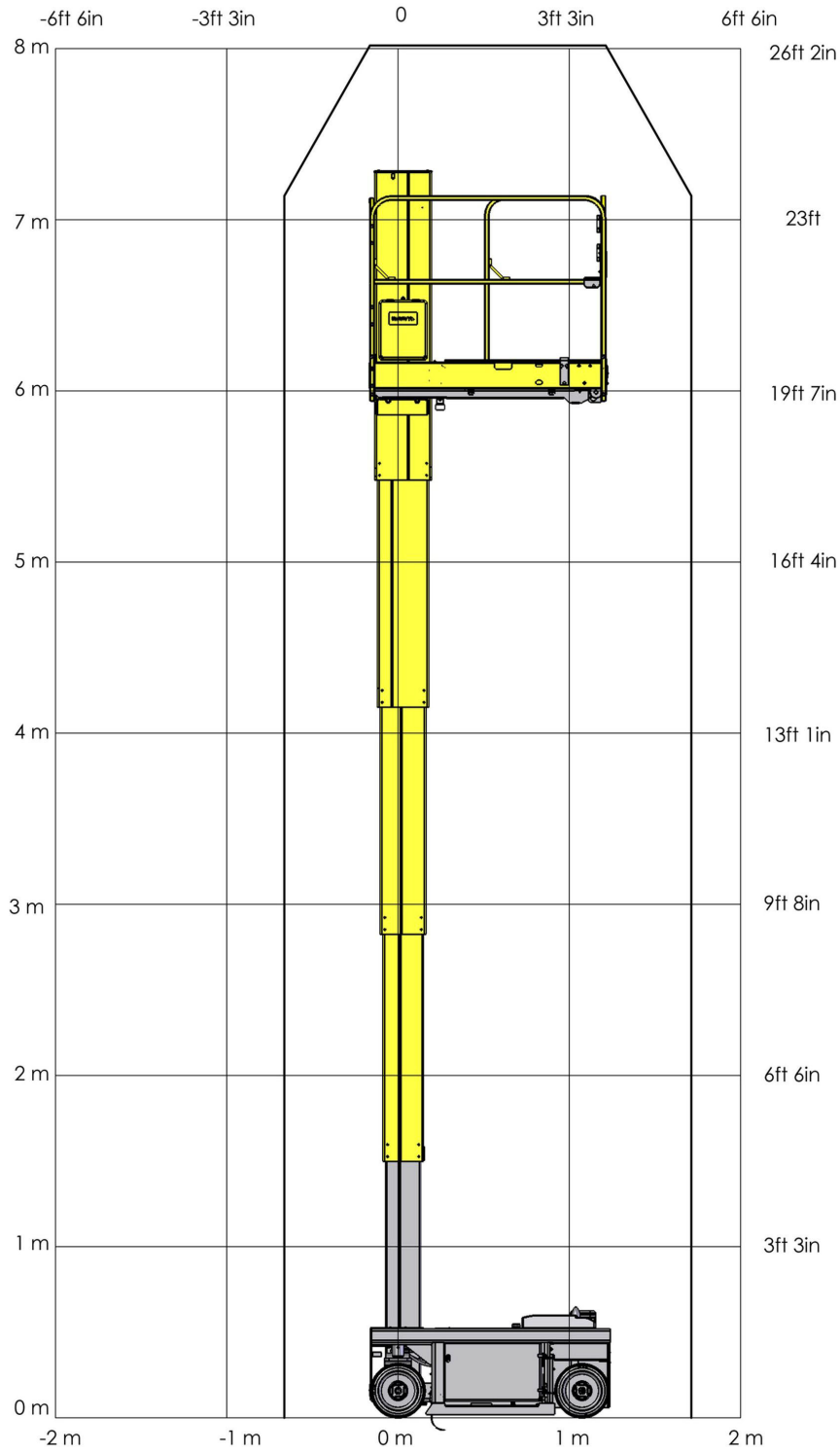

B - Familiarization

5 - Decals and markings locations

CE, UKCA and AS standards - 4000389530 L - STAR 8S

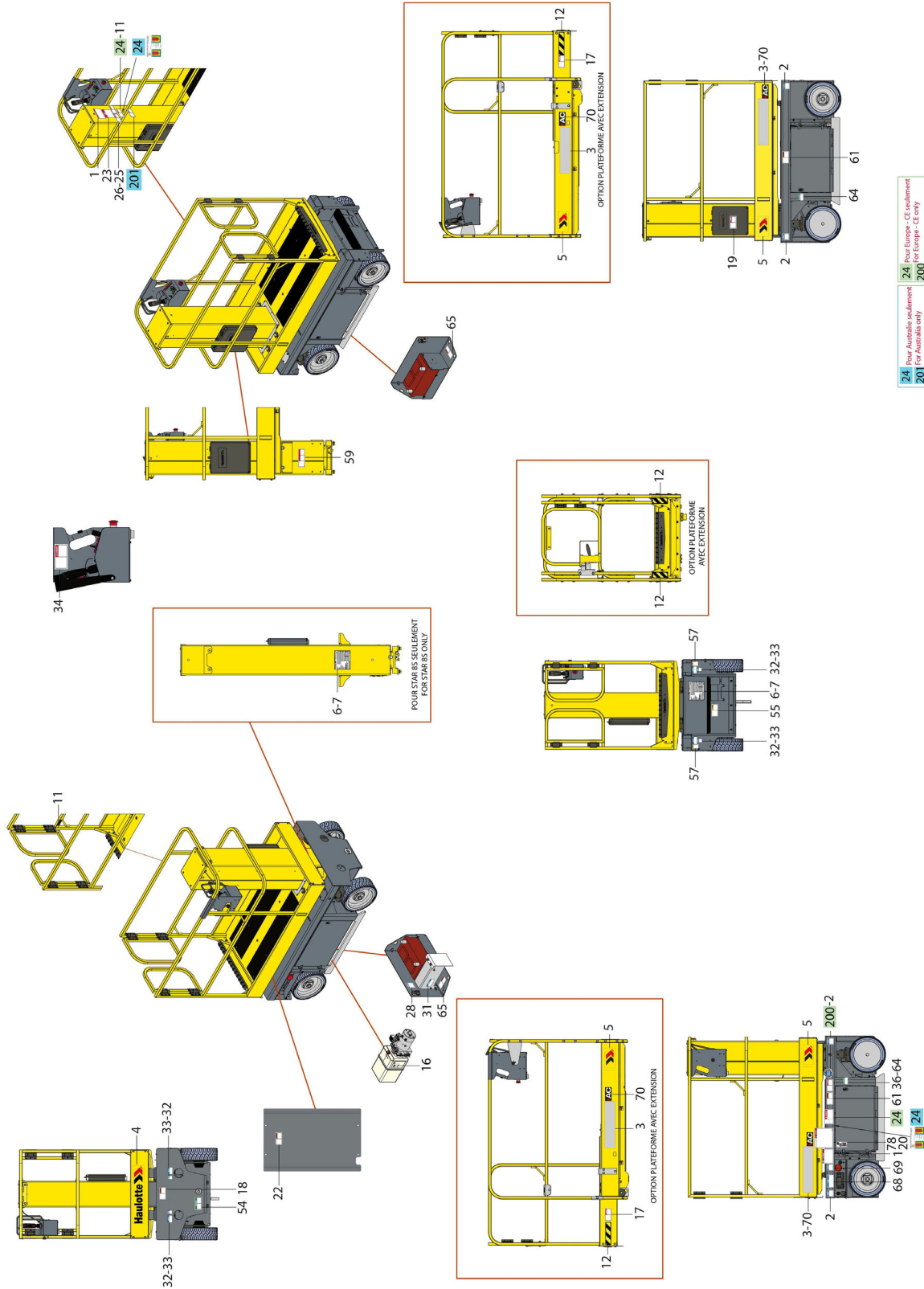

24 Pour Europe - CE seulement
201 Pour Australie seulement
200 Pour Europe - CE only

B - Familiarization

CE, UKCA and AS standards

Marking	Color	Description	Quantity	STAR 8S with platform extension
1	Red	Height of the floor and load	2	4000816020
2	Blue	Maximum Pressure per Tire - Floor Loading	4	4000824390
3	Other	Commercial name - Bright machine	2	4000527060
3	Other	Commercial name - Dark machine	2	4000527070
4	Other	Decal HAULOTTE® - Bright machine	1	307P217080
4	Other	Decal HAULOTTE® - Dark machine	1	307P224740
4	Other	Decal HAULOTTE® - Red machine	1	307P220360
5	Other	Decal HAULOTTE® - Bright machine	2	4000425360
5	Other	Decal HAULOTTE® - Dark machine	2	4000425370
5	Other	Decal HAULOTTE® - Red machine	2	4000425380
6	Other	Identification plate	1	For CE and AS standards only : 4000700140 UKCA standard only : 4001188220
11	Other	Lanyard attachment points	4	307P216290
12	Other	Material risk - Yellow and black adhesive tape	2	4000478920
12	Other	Material risk - Yellow and black adhesive tape	2	4000424630
16	Other	Max and min oil level	1	307P221060
17	Red	Risk of crushing	2	4000272910
18	Orange	Hand crushing hazard - Risk of crushed hands	1	4000024890
19	Red	Operation instructions	1	4000025140

B- Familiarization

Marking	Color	Description	Quantity	STAR 8S with platform extension
20	Red	Operation instructions	1	In english (CE, UKCA and AS standards) : 307P222740 In german (CE and UKCA standards) : 307P222730 In chinese (CE and UKCA standards) : 4000696620 In korean (CE and UKCA standards) : 4000618590 In croatian (CE and UKCA standards) : 4000360810 In danish (CE and UKCA standards) : 307P222760 In spanish (CE and UKCA standards) : 307P222770 In estonian (CE and UKCA standards) : 4000360870 In finnish (CE and UKCA standards) : 307P222780 In french (CE and UKCA standards) : 3078149030 In greek (CE and UKCA standards) : 4000561810 In dutch (CE and UKCA standards) : 307P222790 In hungarian (CE and UKCA standards) : 4000360890 In italian (CE and UKCA standards) : 307P222800 In japanese (CE and UKCA standards) : 4000359830 In latvian (CE and UKCA standards) : 4000359840 In lithuanian (CE and UKCA standards) : 4000359850 In norwegian (CE and UKCA standards) : 4000359900 In polish (CE and UKCA standards) : 4000359860 In portuguese (CE and UKCA standards) : 307P222810 In romanian (CE and UKCA standards) : 4000359870 In slovakian (CE and UKCA standards) : 4000359880 In slovenian (CE and UKCA standards) : 4000359890 In swedish (CE and UKCA standards) : 307P222820
22	Orange	Wound foot - Do not place foot	1	4000027090
23	Red	Risk of crushing - Driving direction	1	3078145100
24	Red	Danger of electrocution	2	For CE and UKCA standards only : 4000273930 For AS standard only : 4000227500
25	Red	Risk of crushing - Closing drop rail	1	4000025080

B - Familiarization

Marking	Color	Description	Quantity	STAR 8S with platform extension
26	Red	Danger of electrocution - Ground for welding	1	4000027100
28	Red	Do not interchange	1	4000504670
31	Blue	Brake release	1	4000361570
32	Blue	Anchorage point - Tie down for transportation	4	4000027310
33	Blue	Anchorage point - Lifting eyes	4	4000027330
34	Red	Risk of electrocution - Water projection	1	4000025130
36	Red	Risk of crushing - Platform	1	4000318140
54	Green	Emergency lowering	1	4000481210
55	Yellow	Risk of electrocution - Charger - 240 V	1	For CE and UKCA standards only : 4000273940 For AS standard only : 4000307410
57	Orange	Position of the lift truck forks	2	3078143830
59	Red	Safety prop	1	4000467300
61	Orange	Risk of crushed feet	2	4000025060
64	Green	Battery verification	2	4000274040
65	Orange	Hand crushing hazard - Battery	2	4000027440
68	Blue	Transport height	1	4000529600
69	Blue	Battery isolation switch	1	4000420660
70	Other	Electric traction	2	4000425350
78	Other	QR Code ( https://www.e.technical-information.com)	1	4001089310
200	Other	"Made in Europe"	1	For CE and UKCA standards only : 4000137690
201	Red	Wearing of a safety harness is essential	1	For AS standard only : 4000275670

B- Familiarization

EAC standard - 4000424680 L - STAR 8S

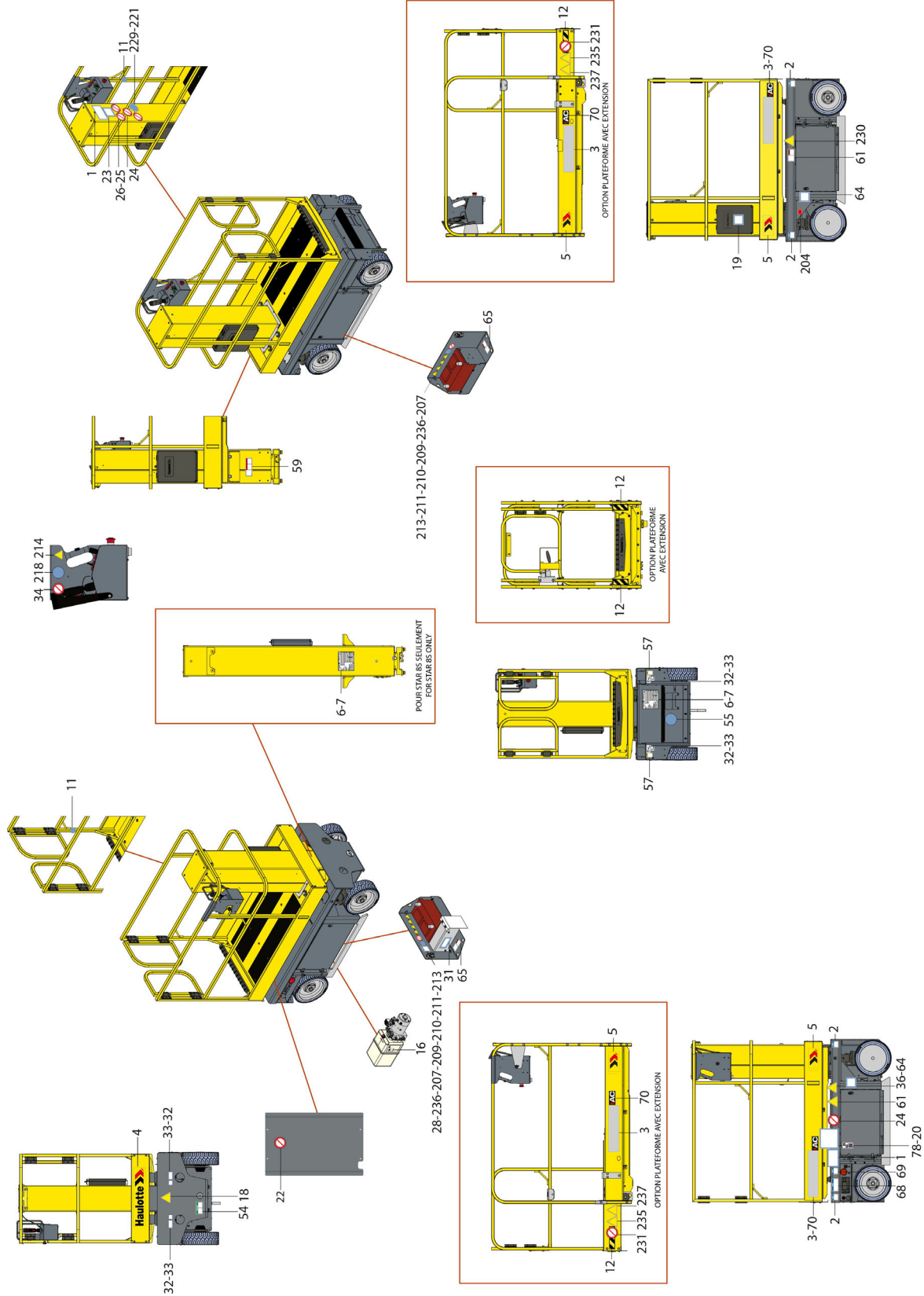

B - Familiarization

EAC standard

Marking	Color	Description	Quantity	STAR 8S with platform extension
1	Red	Height of the floor and load	2	4000816100
2	Blue	Maximum Pressure per Tire - Floor Loading	4	4000824390
3	Other	Commercial name - Bright machine	2	4000527060
3	Other	Commercial name - Dark machine	2	4000527070
5	Other	Decal HAULOTTE® - Bright machine	2	4000425360
5	Other	Decal HAULOTTE® - Dark machine	2	4000425370
5	Other	Decal HAULOTTE® - Red machine	2	4000425380
6	Other	Identification plate	1	For Russia : 4000388680 For Ukraine : 4000054150
11	Other	Lanyard attachment points	4	307P226710
12	Other	Material risk - Yellow and black adhesive tape	2	4000478920
12	Other	Material risk - Yellow and black adhesive tape	2	4000424630
16	Other	Max and min oil level	1	307P221060
18	Orange	Hand crushing hazard - Risk of crushed hands	1	307P227660
19	Red	Operation instructions	1	For Russia : 307P227190 For Ukraine : 307P227840
20	Blue	Operation instructions	1	For Russia : 4000359920 For Ukraine : 4000359910
22	Orange	Wound foot - Do not place foot	1	307P227010
23	Red	Risk of crushing - Driving direction	1	For Russia : 4000010890 For Ukraine : 4000011390
24	Red	Danger of electrocution	2	307P226960
25	Red	Risk of crushing - Closing drop rail	1	307P226950
26	Red	Danger of electrocution - Ground for welding	1	307P226970
28	Red	Do not interchange	1	4000504670
31	Blue	Brake release	1	4000361570
32	Blue	Anchorage point - Tie down for transportation	4	4000135970
33	Blue	Anchorage point - Lifting eyes	4	4000135960
34	Red	Risk of electrocution - Water projection	1	307P226780
36	Red	Risk of crushing - Platform	1	4000014290
54	Green	Emergency lowering	1	4000481210
55	Yellow	Risk of electrocution - Charger - 240 V	1	307P227520
57	Orange	Position of the lift truck forks	2	4000013830
59	Red	Safety prop	1	4000467300
61	Orange	Risk of crushed feet	2	4000270970
64	Green	Battery verification	2	For Russia : 307P227180 For Ukraine : 307P227860
65	Orange	Hand crushing hazard - Battery	2	4000027440

B- Familiarization

Marking	Color	Description	Quantity	STAR 8S with platform extension
68	Blue	Transport height	1	4000529600
69	Blue	Battery isolation switch	1	4000420660
70	Other	Electric traction	2	4000425350
78	Other	QR Code ( https://www.e.technical-information.com)	1	4001089310
204	Red	Lubrication point	2	307P219370
207	Red	Smoking forbidden	2	307P226760
209	Yellow	Battery danger	2	307P226790
210	Yellow	Fire Hazard	2	307P226800
211	Yellow	Electrical danger	2	307P226810
213	Yellow	Corrosion hazard	2	307P226830
214	Yellow	Danger unstable side	1	307P226930
218	Blue	Caution helmet compulsory	1	307P226680
221	Blue	Obligatory routing	1	307P227510
229	Red	Do not travel down slopes in high speed	1	307P226990
230	Red	No admittance to unauthorized persons	2	307P227560
231	Red	Do not park in the work area	2	307P227000
235	Yellow	Vertical crushing of the body	2	4000014270
236	Blue	Caution glasses	2	307P226670
237	Yellow	Risk of crushing	2	307P227670

B - Familiarization

ANSI and CSA standards - 4000424690 O - STAR 20

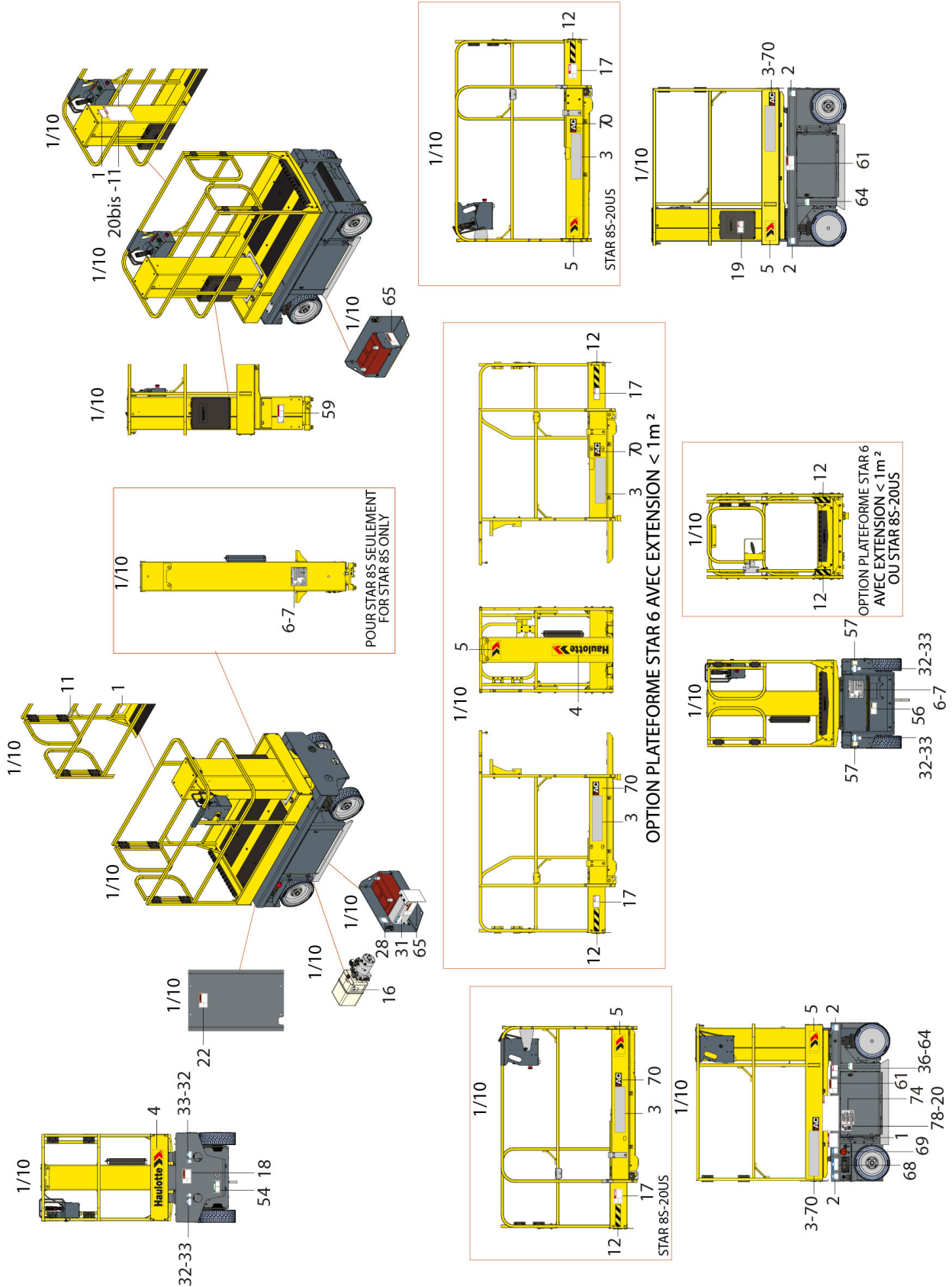

B- Familiarization

ANSI and CSA standards

Marking	Color	Description	Quantity	STAR 20 with platform extension
1	Red	Height of the floor and load	3	4000816020
2	Blue	Maximum Pressure per Tire - Floor Loading	4	4000824390
3	Other	Commercial name - Bright machine	2	4000527100
3	Other	Commercial name - Dark machine	2	4000527120
4	Other	Decal HAULOTTE® - Bright machine	1	307P217080
4	Other	Decal HAULOTTE® - Dark machine	1	307P224740
4	Other	Decal HAULOTTE® - Red machine	1	307P220360
5	Other	Decal HAULOTTE® - Bright machine	2	4000425360
5	Other	Decal HAULOTTE® - Dark machine	2	4000425370
5	Other	Decal HAULOTTE® - Red machine	2	4000425380
6	Other	Identification plate	1	4000700150
11	Other	Lanyard attachment points	4	307P216290
12	Other	Material risk - Yellow and black adhesive tape	2	4000478920
12	Other	Material risk - Yellow and black adhesive tape	2	4000424630
16	Other	Max and min oil level	1	307P221060
17	Red	Risk of crushing	2	In english : 4000275590 In french : 4000275600 In spanish : 4000275610
18	Orange	Hand crushing hazard - Risk of crushed hands	1	In english : 4000024770 In french : 4000067710 In spanish : 4000086490
19	Red	Operation instructions	1	4000025140
20	Red	Operation instructions	1	In english : 4000027580 In french : 4000083200 In spanish : 4000086650
20bis	Red	Operation instructions	1	In english : 4000326910 In french : 4000326310 In spanish : 4000326900
22	Orange	Wound foot - Do not place foot	1	In english : 4000024840 In french : 4000068180 In spanish : 4000086610
28	Red	Do not interchange	1	4000504670
31	Blue	Brake release	1	4000361570
32	Blue	Anchorage point - Tie down for transportation	4	4000027310
33	Blue	Anchorage point - Lifting eyes	4	4000027330
36	Red	Risk of crushing - Platform	1	4000318140
54	Green	Emergency lowering	1	4000481210
56	Yellow	Socket - 110 V	1	4000419150
57	Orange	Position of the lift truck forks	2	3078143830
59	Red	Safety prop	1	4000467300

B- Familiarization

Marking	Color	Description	Quantity	STAR 20 with platform extension
61	Orange	Risk of crushed feet	2	In english : 4000024780 In french : 4000067700 In spanish : 4000086480
64	Green	Battery verification	2	4000274040
65	Orange	Hand crushing hazard - Battery	2	In english : 4000025030 In french : 4000068120 In spanish : 4000086550
68	Blue	Transport height	1	4000529600
69	Blue	Battery isolation switch	1	4000420660
70	Other	Electric traction	2	4000425350
74	Other	California warning - P65	1	4001026850
78	Other	QR Code ( https://www.e.technical-information.com)	1	4001089310
Not shown	Other	Information - Canada	2	4000832390

C - Pre-operation inspection

1 - Recommendations

The owner, the site manager, the supervisor and the operator are all responsible to ensure the machine is fit for the work it is to perform; i.e. that the machine is suitable to carry out the work in complete safety and in compliance with this Operator's Manual. All managers who are responsible for persons operating the machine must be familiar with the local regulations currently applicable in the country of use and ensure that they are adhered to.

Before using the machine, read the previous chapters in this manual. Ensure that you have understood the following points :

- Safety precautions.
- Operator's responsibilities.
- Conditions and the operating principles of the machine.

2 - Working area assessment

Before carrying out any operations, ensure that the machine corresponds to the work to be done and the working environment :

- Carry out a thorough inspection of the site to identify any potential risks within the work zone.
- Take the necessary precautions to avoid collisions with other machinery within the work zone.

Ensure that :

- The weather conditions (wind, rain, etc.) allowing the machine to be used.
- The ground withstands the weight of the machine and has not been affected by the poor weather conditions.
- Check that the authorisations to work with the machine on the site in question have been obtained (.g. chemical product factories).
- Define a rescue plan for all the risks, including the risk of falls and crushing.

C- Pre-operation inspection

3 - Inspection and Functional test

3.1 - DAILY INSPECTION

Each day before the beginning of a new work session and with each change of operator, the machine must be subjected to a visual inspection and a complete functional test.



- Never use a defective or a malfunctioning aerial work platform.
- If any item on the check list is marked "No" during the inspection; machine must be tagged and placed out of service.
- Do not operate the machine until all identified items are corrected and it has been declared safe for operation.

In case of loose fasteners, refer to torque table value in maintenance book.

In case of leaks, replace the damaged part before use.

In case of structural part deformation (cracks, broken weld, paint chips) replace the part before use.

Sample of broken welds

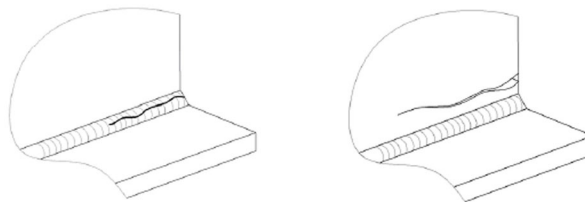

We recommend these forms to be completed daily and stored to assist with your maintenance schedule.

Each action is depicted in the daily inspection sheet using the following symbols.











Use the detailed program below.

	Oil change		Lubrication-Lubrication		Tightening
	Levelling		Systematic replacement		Functional adjustments / Checks / Cleaning
	Visual inspection		To check by test		

Serial number :	Model :
Hours of operation :	
HAULOTTE Services® contract reference :	
Intervention record number :	
Date :	
Name :	
	Signature :

C- Pre-operation inspection

Telescopic masts

	Page or associated procedure	Daily	OK	NOK	Corrected	Comments
Chassis assembly : Wheel, reducer, steering, wheel pivot						
Check state of tires/tyres and inflations						
Batteries						
Check the battery level						
Check the condition of the battery						
Check the operation of the lock on the engine casing						
Hydraulic : oils, filters and hoses						
Check the hydraulic oil level (Top up the oil if necessary ; Machine stowed)						
Check the clogging indicator on the hydraulic pressure filter (change if clogged)						
Check the hoses, blocks and pumps, fittings, cylinders and the tank for the absence of leaks, deformations and damage						
Platform						
Ensure that the gate or sliding bar shall be designed to either return automatically to the closed and latched position						
Check that the harness anchor points are not cracked or damaged						

A

B

C

D

E

F

















G

H

I

C- Pre-operation inspection

Telescopic masts

	Page or associated procedure	Daily	OK	NOK	Corrected	Comments
General						
Check for the presence, cleanliness and readability of the manufacturer's plates, security labels, user manual and maintenance manual						
Check the cleanliness and readability of the control box						
Test the opening and closure of covers (chassis, turntable, upper control box)						
Check the condition of electrical harnesses, cables and connectors						
Check for the absence of abnormal noise and jerky movements						
Check for the absence of visible deterioration and damage						
Check for the absence of cracks, broken welds and chipped paintwork on the structure						
Check for the absence of missing or loose screws and bolts						
Check for the absence of deformation, cracking and breakage of axis stops, bushing and axes						
Check for the absence of foreign bodies in joints and sliding parts						
Safety devices						
Test the operation of the upper and lower control boxes: manipulators, switches, buttons, horn, emergency stops, screens and lights						
Check the absence of visual and audible alarms						
Test the operation of the tilt system						
Test the operation of the emergency lowering system						
Test the operation of the load control system - Calibrate if necessary						

C - Pre-operation inspection

4 - Safety functional checks

To protect the user and the machine, safety systems prevent the movement of the machine beyond its operating limits. These safety systems when activated immobilize the machine and prevent further movement.

The operator must be familiar with this technology and understand that is not a malfunction but an indication that the machine has reached an operation limit.

Aerial Work platforms are equipped with two control boxes which allow operators to safely use the machine. A mast lowering device is provided on the chassis to assist in emergency situations. Each control box is equipped with an E-Stop button, which cuts all movements when pushed in.

The following checks describe the operation of the machine and the specific controls required.

For the location and description of these controls :  refer to section B 3.4 and D 2 - Ground panel and B 3.5 and D 3 - Platform panel.

4.1 - E-STOP BUTTON CHECK

Ground control box E-stop button

Step	Action
1	Pull the E-Stop button (15) at the ground control box.
2	Turn the control box activation selector key (92) downwards to activate the ground control box.
3	The ground control box screen turns on.
4	Push the E-stop button (15). The screen turns off.

Platform control box E-stop button

Step	Action
1	Pull the E-stop buttons (15, 46).
2	Turn the control box activation selector key (92) upwards to activate the platform control box.
3	Push the E-stop button (46). The system is de-energized and no function is operable.

4.2 - ACTIVATION OF CONTROLS

The enable switch must be active to allow any movement.

The "Enable Switch" system depends on the machine configuration and will consist of one of the following :

- Enable trigger on platform control joystick.
- Enable switch on the ACTIV'Screen on ground control box.

C - Pre-operation inspection

4.3 - FAULT DETECTOR

The machine is equipped with an on-board fault detection system, which indicates the type of fault to the operator.

The fault is identified by a default code.

The default code is displayed at the ground control box.

According to the type of fault, the machine MAY switch into DOWNGRADEMODE mode and certain movements are prevented to maintain Operator's safety.

Do not use the machine until the fault has been corrected.

4.3.1 - Buzzers test

From the ground control box

Step	Action
1	Pull both the E-Stop buttons (46) at platform box and (15) at ground box.
2	Turn the control box activation selector key (92) downwards or upwards to activate a control box.
3	Check that the audible beep sounds.

4.4 - OVERLOAD SENSING SYSTEM

If the platform load exceeds the maximum allowed load, no movement is possible from the 2 control boxes.

At ground and platform control boxes a buzzer sounds and an indicator light warns the operator.

To return the machine to normal operation remove weight from the platform until the load is below the maximum allowed load.

Daily check that the LED's illuminate when the machine is switched on :

- Verify that the Overload system is active : Refer to Indicator (6) at ground control box and LED (30) at platform control box display.
- Verify that the buzzers are functioning : Refer to Buzzers test.

A periodic inspection of this device must be performed according to the recommendation in Maintenance Schedule.

C - Pre-operation inspection

4.5 - SLOPE WARNING DEVICE

From each control box, a buzzer alerts the operator that the machine is not folded/stowed and is positioned on a slope exceeding the slope allowed.

N.B.-:-THE SLOPE SENSOR IS ONLY ACTIVE WHEN THE PLATFORM IS NOT IN THE STOWED POSITION.

When machine is on a slope greater than the rated slope, with extending structure out of the stowed position :

- The DRIVE and LIFTING (RAISING) commands are deactivated.

The lowering speeds are reduced.

In this case, fully lower the platform and reposition the machine on level ground before raising the platform again.

To check the tilt sensor at ground level, perform the following steps :

Daily check

Step	Action
1	Put the machine in stowed position on a slope with an angle greater than the permitted inclination (Refer to  Section B 4.1 Technical specifications).
2	Check that the tilt indicator is on (27).

4.6 - TRAVEL SPEED LIMITATION

Drive speed is proportional to control until the maximum speed is reached (machine in fully stowed position)

The only speed allowed when not in stowed position is microspeed (This speed is a default speed programmed into the machine).



Drive speed is automatically limited when the machine is traveling on slope.

4.7 - ELECTRONIC VARIABLE SPEED DRIVE

The machine is equipped with 2 electronic variable speed regulators configured for each function that manages the amount of power sent to each motor.



Do not interchange the speed controllers/regulators between machines even if they are the same model.

C - Pre-operation inspection

4.8 - ON-BOARD ELECTRONICS

The machine is equipped with a specific calculator configured for this machine's functionalities. Do not interchange the Calculator (calibration restoration) between machines..

4.9 - MACHINE BRAKING

When electric power is cut off, the machine stops automatically.

Performance levels may be reduced in the following situations :

- Descending a bumpy or slippery ramp
- Worn tires/tyres.
- Damp or muddy ground conditions.

Check that the brakes are applied automatically when the Drive joystick is released to the neutral position.

4.10 - WHEEL MOTOR BRAKE RELEASE

Each time a drive command is activated, electric power releases the brakes.

4.11 - POTHOLE PROTECTION SYSTEM

The machine is equipped with a pothole mechanism under the chassis that is deployed automatically when the platform is out of the stowed position.

Check the system for damage and ensure that it deploys when the platform is raised.

4.12 - ON-BOARD CHARGER

Battery charging starts as soon as an external supply is connected to the battery charger.



When the battery pack is being charged with an external power supply, the machine's electric system is automatically deactivated.

D - Operation instructions

1 - Operation

1.1 - INTRODUCTION

Aerial Work platforms are equipped with two control boxes which allow operators to safely use the machine.

An auxiliary device is available on the chassis to assist with the emergency rescue of people.

Each control box is equipped with an E-Stop button, which allows operators to stop all movements, if necessary.

Only trained and authorized personnel shall be permitted to operate this aerial work platform.

Prior to operation :

- Read, understand and obey all instructions and safety precautions in this manual and attached to the aerial work platform.
- Read, understand and obey all local regulations.
- Become familiar with the proper use of all controls and emergency systems.

1.2 - OPERATION FROM THE GROUND CONTROL BOX

- Turning "ON" and "OFF" of the machine is performed with selector key switch (92).
- Activation of a desired control box is achieved by turning the control box energizing selector switch (92) to the desired position.
- The ground control box is energized and is active ONLY when :
 - The emergency stop on the ground control box is not pushed in.
 - The machine is switched on.
 - Ground control box is selected.
- An E-stop button at each control box stops all movements when pressed in (deactivated).

N.B.-:-AN E-STOP BUTTON PRESSED IN DOES NOT TURN OFF THE MAIN POWER SUPPLY TO THE MACHINE.

- An Enable Switch (9) provided must be activated and maintained to authorize one or more function movements. If Enable Switch (9) is kept engaged without selecting a function movement for more than 8 s; Enable Switch is automatically de-activated.
- The release of "Enable switch" (9) while performing a movement stops all the movements. The stop of movements is progressive. If the Enable Switch system is re-pressed, the movement doesn't restart. It could restart only when the selected function switch/joystick is released to neutral position.
- All switches and joystick operating a movement, return automatically to neutral when released.

D- Operation instructions

- At power up, a switch in it's neutral position will be taken into account to authorize movement.
- The ground control box is designed for maintenance and emergency rescue operations only.
- The status of the switches is tested automatically when the machine is switched on, and checked at every starting. A switch will be active only after it has been detected to be in neutral position. The following switches are not controlled :
 - Beacon light (if fitted)

A buzzer beeps in the following conditions :

- Machine out of stowed position and on a slope greater than allowable slope.
- Hydraulic oil overheating.
- Movements option.
- Indicators / Cluster : All indicators are checked after powering on the machine

D - Operation instructions

1.3 - OPERATION FROM THE PLATFORM CONTROL BOX

- The platform control box can only be used if :
 - The E-stop buttons on both ground and platform control boxes are not pressed in.
 - Machine switched on at ground control box.
 - Platform control box selected from ground control box.
- A faulty joystick is not taken into account to control a movement. If this fault disappears, the movement is authorised again.
- An E-Stop button is present at each control box. When pushed in, it stops all functions movements.
- An Enable /Foot Switch (123) is present that should be activated and maintained to authorize one or more movements. If the Enable Switch is kept active for more than 8 seconds without selecting a function movement, then movement is disallowed. The enable switch must be released before movement can occur.
- The release of "Enable switch" (123) while performing a movement stops all the movements. The stop of movements is progressive. The function movements can only be selected when the corresponding function switch is returned to neutral position.
- All switches and joystick operating a movement, return automatically to neutral when released.
- The status of the switches and joysticks is tested automatically when the machine is switched on. A switch or joystick will be active only after it has been detected in neutral position.

A buzzer beeps in the following conditions :

- Machine elevated on a slope greater than the rated slope.
- Indicators - All the indicators are tested
 - When the machine is switched on.

D - Operation instructions

2 - Ground control box

2.1 - TO START AND STOP THE MACHINE

- Pull the E-Stop button at the ground control box.
- Turn the control box activation selector key (92) downwards to activate the ground control box.

To shut-down the machine from the ground control box :

- Turn the control box activation selector (92) key to the center.
- Press in the E-Stop button on the ground control box.

N.B.-:THE ACTIV'SCREEN AUTOMATICALLY GOES INTO STANDBY IF IT IS NOT USED FOR AN EXTENDED PERIOD. TO SWITCH THE ACTIV'SCREEN BACK ON, TURN THE KEY SELECTOR TO POSITION OFF THEN FOLLOW THE START-UP PROCEDURE.

2.2 - MOVEMENT CONTROL





Even at low movement speeds, use the controls with caution.

Press and hold 'Enable switch' button (9) to perform movements.

N.B.-:RELEASING THE ENABLE SWITCH WILL STOP ALL MOVEMENTS.

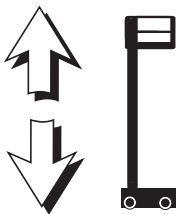
Ground box controls (emergency station)

Command	Action
Mast lifting / descent 	 Press the mast extension touchpad (1) to telescope the mast.
	 Press the mast retraction touchpad (10) to retract the mast.

2.3 - ADDITIONAL CONTROLS

For the machines equipped with beacon light :

- Press and hold the beacon button (105) to activate. Release beacon button (105) to turn OFF.

D - Operation instructions

3 - Platform control box

3.1 - TO START AND STOP THE MACHINE

To start the machine :

At the ground control box :

- The E-stop button on the ground control box must be in ON position (pulled out / activated).
- Turn the control box activation selector key (92) upwards to activate the platform control box.

At the platform :

- Pull the E-stop button (46).

To stop the machine (Only in the event of an emergency) :

- Push in the E-stop button (46).

N.B.-:-THE ACTIV'SCREEN AUTOMATICALLY GOES INTO STANDBY IF IT IS NOT USED FOR AN EXTENDED PERIOD. TO SWITCH THE ACTIV'SCREEN BACK ON, PRESS THE EMERGENCY STOP BUTTON THEN FOLLOW THE START-UP PROCEDURE.

3.2 - DRIVE AND STEER CONTROL

To operate driving/steering functions, move 2 position selector switch (112) to the right. Activate driving selection indicator (111). Simultaneously operate drive joystick (108) with joystick trigger (Enable switch (123)) pressed in and maintained.



While machine is on a slope, take extra precautions :

- to make sure that the machine does not over steer.
- to make sure there is NO loss of traction causing machine movement.



Do not drive down the slopes/grades or ramps with slippery surfaces (e.g.: paint, ice or other similar conditions) as traction may be reduced.



On ramp, select low drive speed (45) to avoid any risk of sliding.

D - Operation instructions

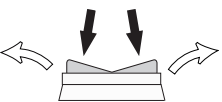
Command		Action
Driving		Move the drive joystick (108) forwards to drive the machine forwards.
		Move the drive joystick (108) backwards to drive in reverse.
Steering thumb button on joystick		Press right side of thumb button (108) on joystick to steer to the right.
		Press left side of thumb button (108) on joystick to steer to the left.

3.3 - MOVEMENT CONTROL

To operate Mast Extension / Retraction function, move 2 position selector switch (112) to the left. Mast extension / retraction indicator (110) lights up when activated. Simultaneously operate joystick (108) with joystick trigger (Enable switch (123)) pressed in and maintained for desired extension/retraction.

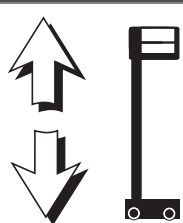
Command		Action
Mast lifting / descent		Push the joystick (108) forwards to extend the mast.
		Pull the joystick (108) backwards to retract the mast.

3.4 - ADDITIONAL CONTROLS

- Horn : Push the horn selector (43) to the right to sound the horn. The horn stops when the selector switch is released.

D - Operation instructions

4 - Rescue and emergency procedures

In case of power loss or if an operating problem prevents the platform occupant from descending, a competent operator can perform the emergency procedures from the ground level.

In an emergency, if the operator has to exit the platform while it is elevated, the transfer of the operator must respect the following recommendations. :

- Exit onto a sturdy and safe structure.
- The occupant(s) must ensure that 2 lanyards are used for security/safety. One must be attached to the designated anchorage point on platform the occupant(s) is in and the other attached to the structure intended to get on.
- Occupant(s) must exit the current platform through the normal access.

4.1 - MAST MANUAL LOWERING PROCEDURE

- Press and hold the push button (1) on front of the machine, to lower the mast.
- Release it to halt lowering.

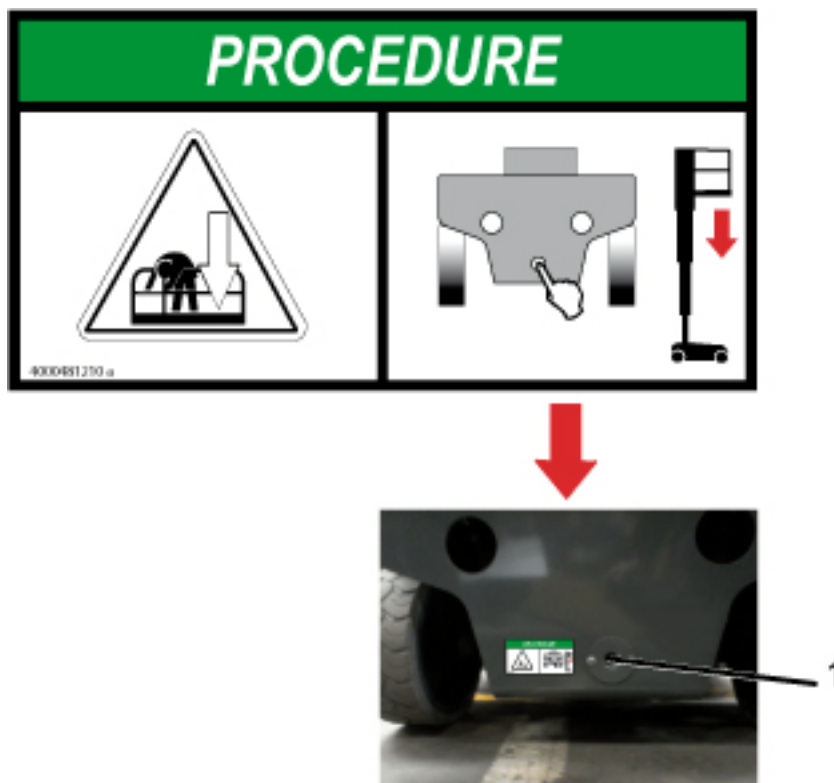

D - Operation instructions

5 - Transportation

5.1 - PUTTING IN TRANSPORT POSITION

During loading, ensure that :

- The loading ramp can support the machine weight.
- The loading ramp is correctly attached to transport vehicle.
- The loading ramp has sufficient grip surface.
- The transport vehicle must be parked on a level surface and must be secured to prevent rolling away while machine is being loaded or unloaded.

To climb the slope, move progressively the drive joystick (108).

If the slope is too steep, use a winch in addition to traction.

Do not place yourself below or too close to the machine during loading.

The machine must be completely in the stowed configuration :

- Check the platform is completely empty.
- Drive the machine onto the truck bed.
- Secure the machine to the tie down points provided (See picture).
- The covers must be locked.



The manual extension (if fitted) must be retracted and locked during transport or towing.

- Secure the machine to the tie down points provided (See picture).
- The covers must be locked.



The extension deck must be retracted and locked during transport or towing.

D - Operation instructions

5.2 - MACHINE LAYOUT — STAR 6 - STAR 13 - STAR 8S - STAR 20

STAR 6 - STAR 13 - STAR 8S - STAR 20

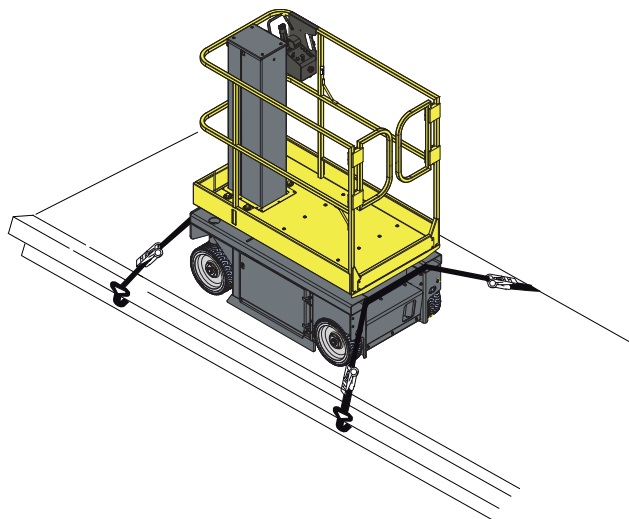

5.3 - UNLOADING

Before unloading, check that the machine is in good condition.

- Remove the tie downs.
- Switch the machine on.
- Pull out the E-stop button if it was pressed in.
- Check that the platform indicators are ON.
- Move 2 positions selector switch (112) to the right. Driving / Steering indicator (111) lights up when activated. Simultaneously operate drive joystick (108) with enable switch (123) or Foot Switch (C42) (if equipped) pressed in and maintained.



Warning : Upon starting a machine that has been secured and transported, the safety system may detect a false overload preventing all movement from the platform control box.

To reinstate the system, lift the platform a few centimetres (inches) from the ground control box.

- Switch the machine on.
- Move progressively the drive joystick (108).

D - Operation instructions

5.4 - TOWING



In the event of a machine breakdown, the machine can be towed a short distance to load it onto a transport vehicle :

- Ensure that no one is in the platform during towing.
- Prior to towing, ensure mast is fully retracted.
- The platform must be empty.
- **ALWAYS** keep personnel and obstructions clear of the aerial work platform when brakes are released.

To tow a broken-down machine, release brake (Refer to  Section D 5.4.1 - Brake release). Perform this operation on flat ground with wheels chocked.

In the towing configuration, the machine braking system is inactive. Use of a drawbar is recommended :

- Do not exceed the maximum freewheel speed (Refer to  Section B 4.1 - Technical specifications).
- Do not exceed a grade of 25%.

5.4.1 - Electric brake release

To tow a broken-down machine, the brakes can be released using the electric system.



Perform these operations on flat, horizontal ground. Failing that, block the wheels to immobilize the machine. During brake release operation, the machine is in free wheel mode and the brake system no longer functions.

D - Operation instructions

If the machine needs to be towed, the drive wheels brake release is located inside the battery bay (ground control box side).

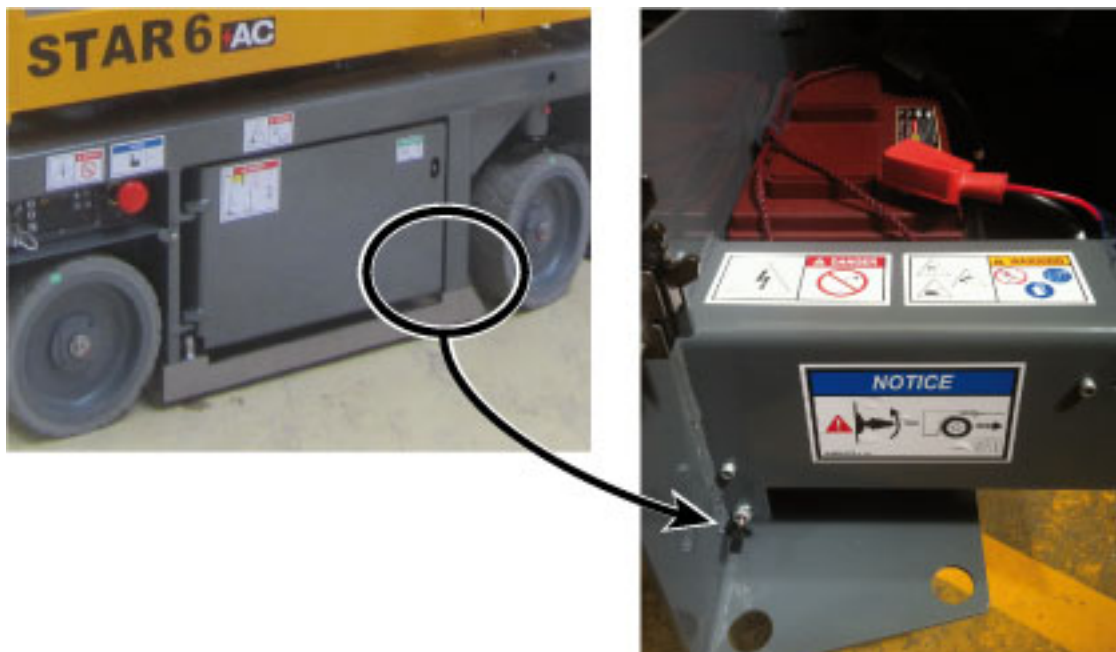

To release the machine's brakes, the following conditions must be met :

- The platform control box or the ground control box must be selected.
- The machine must be completely stowed.
- No movement selected.
- The machine must not be tilted.

Hold brake switch upwards to activate the brake release.

Push the brake release button for at least 3 s. An audible signal (beep) sounds.

Releasing the button disengages the brakes.

The brakes are re-applied automatically when the brake release button :

- is pushed again,
- any actions are taken at the control boxes,
- the machine is turned off,
- or the control box in use is changed.

D - Operation instructions

5.5 - STORAGE



The machine can be stored in a designated area when not in use. If it has been stored for longer than 3 months without use then a periodic inspection must be conducted.



Keep the batteries charged.  [Section D 7.4](#) Optimise battery life

Machine must be parked in a protected/designated area with the mast fully retracted. Make sure there is no load in the platform.

It is recommended that the machine is not stored or immobilized unfolded.

Ensure all access panels, doors and side compartment covers are shut and secured.

Turn the energizing key selector switch (92) at the ground control box to the "center" position to shut OFF the power.

Remove the ignition key to prevent unauthorized operation of the machine.



Storing of the machine with an obstacle under the platform structure is forbidden.



To avoid any risk of corrosion on rods of cylinders during a storage period of more than 1 month :

- In a normal atmospheric environment : perform a complete cycle for the cylinders every 2 months while they are in storage.
- In harsh environments (high levels of salinity in the atmosphere: close to the sea, industrial environment with chloride emissions and/or humidity >70%), we recommend applying the following protection process :
 - Wash and rinse the entire machine with plenty of clean water.
 - Dry all the cylinder rods using an air gun.
 - Apply a solvent-based oil leaving an oily film after evaporation of the solvent directly to all rods left exposed when the machine is in storage position.
 - Re-apply the product every month.



After washing the machine, make sure it is fully air-dry and does not contain moisture on corrosive parts (cylinders rods for example).

Do not wash any electrical components, particularly with high pressure washer. Wipe away dirt from around electrical components with a dry cloth.

D - Operation instructions

5.6 - LOADING BY RAMP



To avoid any risk of sliding during loading, ensure that :

- The loading ramp can bear the load.
- The loading ramp is correctly attached.
- The loading ramp has sufficient grip.



If the slope exceeds 25% grade, use a winch to assist in loading on to the ramp.



Do not drive down the slopes/grades or ramps with slippery surfaces (e.g.: paint, ice or other similar conditions) as traction may be reduced.



Never place yourself below or too close to the machine during loading.

A wrong move can lead to the tipping over of the machine and cause serious bodily and material accidents.

5.7 - UNLOADING BY RAMP



Before operating, check that the machine is in good condition.

If the machine has been damaged during transportation, contact the transporter in writing

1. Remove the tie downs.
2. Start the machine.
3. The ramp is in good condition and of sufficient capacity.



If the slope exceeds 25% grade, use a winch to assist in unloading on to the ramp.



Do not drive down the slopes/grades or ramps with slippery surfaces (e.g.: paint, ice or other similar conditions) as traction may be reduced.

A

B

C

D

E

F

G

H

I

D - Operation instructions

5.8 - LIFTING OPERATION

5.8.1 - Lifting with spreaders

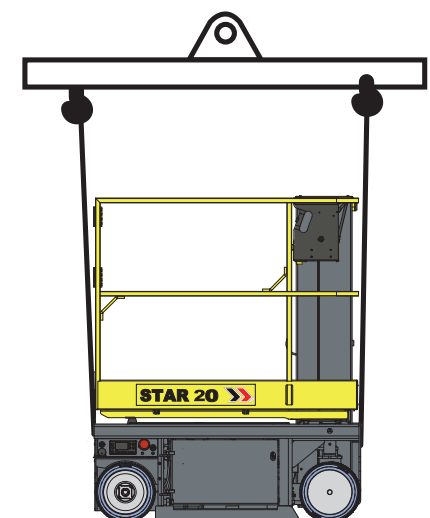

Before any lifting operation, it is necessary to take into account the following points :



ONLY trained and authorized personnel should attempt to lift the machine.

Do not operate machine unless you have :

- been fully trained and are qualified in proper operation.
- read and understood the information in the Operator's manual of the machine.

5.8.1.1 - Safety precautions

It is the responsibility of the Operator to ensure there are no personnel or obstructions to safely perform the operation.

5.8.1.2 - Necessary equipment

Technical specifications

Machine type	Maximum weight
STAR 8S - STAR 20 with platform extension	1150 kg (2,536 lbs)



- PPE (Personal Protective Equipment: glove, safety shoes, glasses, etc ...)
- Standard tool kit
- 1 spreader 2 m (6 ft 7 in) 3T
- 4 shackles 3 T
- 4 slings 3 m (9 ft 10 in) 3 T

D - Operation instructions

5.8.1.3 - Preliminary procedures

- Inspect the surrounding area and position the machine at a safe distance from electrically charged conductors to ensure that no part of the machine is within an unsafe area. Always stay clear of overhead obstructions.
- Respect the local rules and the minimum safe distance from power lines.
- Stop the machine.
- Remove the ignition key.
- Ensure that the main power is disconnected.
- Place a "DO NOT USE" decal near the start/stop switches to inform personnel that machine is not operational during the lifting process.
- Cordon off the area surrounding the machine to keep personnel, vehicles and moving equipment away from the machine.
- Remove all loose items from the machine.
- Ensure that vehicle capacity and loading equipment - hoists, slings, straps, etc. are of sufficient strength to withstand maximum machine weight.
- Attach the rigging ONLY to the designated lifting points on the machine.

5.8.1.4 - Procedure for the use of slings - with spreader

The machine must be completely stowed (Extension retracted). Designated lifting points are marked/labeled with the following symbol .

1. Position the spreader line up with the chassis.
2. Attach 4 shackles 3 T with the straps 3 m (9 ft 10 in) 3 T to the four lifting points on the chassis.

D - Operation instructions

Slings and shackles installation - Front view of the machine



Slings and shackles installation - Rear view of the machine



Pay particular attention to avoid slings over sharp edged surfaces as they may be severed/damaged.



Properly adjust rigging to keep the machine level and to minimize the risk of damage to the machine.



- Lifting procedure must be handled very carefully.
- All movements of the machine must be performed slowly and deliberately to minimize swaying of the machine being lifted.
- Always keep machine as close as possible to the ground level.

D - Operation instructions

5.8.2 - Lifting without spreader

Before any lifting operation, it is necessary to take into account the following points :



ONLY trained and authorized personnel should attempt to lift the machine.

Do not operate machine unless you have :

- been fully trained and are qualified in proper operation.
- read and understood the information in the Operator's manual of the machine.

5.8.2.1 - Safety precautions

It is the responsibility of the Operator to ensure there are no personnel or obstructions to safely perform the operation.

5.8.2.2 - Necessary equipment

Technical specifications

Machine type	Maximum weight
STAR 8S - STAR 20 with platform extension	1150 kg (2,536 lbs)



- PPE (Personal Protective Equipment: glove, safety shoes, glasses, etc ...)
- Standard tool kit
- 4 shackles 3 T
- 4 slings 3 m (9 ft 10 in) 3 T

5.8.2.3 - Preliminary procedures

- Inspect the surrounding area and position the machine at a safe distance from electrically charged conductors to ensure that no part of the machine is within an unsafe area. Always stay clear of overhead obstructions.
- Respect the local rules and the minimum safe distance from power lines.
- Stop the machine.
- Remove the ignition key.
- Ensure that the main power is disconnected.
- Place a "DO NOT USE" decal near the start/stop switches to inform personnel that machine is not operational during the lifting process.
- Cordon off the area surrounding the machine to keep personnel, vehicles and moving equipment away from the machine.
- Remove all loose items from the machine.
- Ensure that vehicle capacity and loading equipment - hoists, slings, straps, etc. are of sufficient strength to withstand maximum machine weight.
- Attach the rigging **ONLY** to the designated lifting points on the machine.

D - Operation instructions

5.8.2.4 - Procedure for the use of slings - without spreader

The machine must be completely stowed (Extension retracted). Designated lifting points are marked/labeled with the following symbol .

Attach 4 shackles 3 T with the straps 3 m (9 ft 10 in) 3 T to the four lifting points on the chassis.



Pay particular attention to avoid slings over sharp edged surfaces as they may be severed/damaged.



Properly adjust rigging to keep the machine level and to minimize the risk of damage to the machine.



- Lifting procedure must be handled very carefully.
- All movements of the machine must be performed slowly and deliberately to minimize swaying of the machine being lifted.
- Always keep machine as close as possible to the ground level.

D - Operation instructions

5.9 - LOADING AND UNLOADING WITH FORKLIFT

- Completely lower the mast.
- Ensure that the potholes are retracted.



The machine must be in the fully stowed transport position.

- Ensure that the machine controls are in the OFF position.
- Forklift used to load and unload must have adequate capacity (Refer to  Section B 4 Technical specifications).
- Adjust the forklift forks spread to match with the machine fork pockets.
- Carefully insert the forklift forks in the designated machine fork pockets.
- Slightly tilt back the forklift forks.

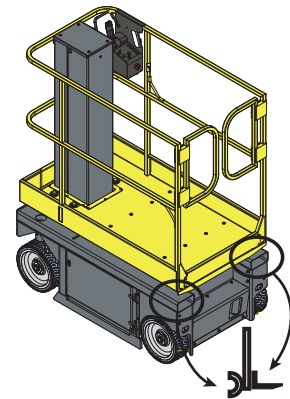

Never place yourself below or too close to the machine during loading.

Brake slowly.

A wrong move can lead to machine tipping over and may cause serious injuries and material damage.

Unloading

- Carefully lift the machine and make sure that the machine weight is properly balanced.
- Slowly lower the machine and place it on the ground.

D - Operation instructions

6 - Cold Weather Recommendations

In extreme cold conditions, machines should be equipped with optional cold start kits.

N.B.-:INITIAL STARTING SHOULD ALWAYS BE PERFORMED FROM THE GROUND CONTROL BOX.

6.1 - ENVIRONMENTAL CONDITIONS

6.1.1 - Hydraulic oil

External environmental conditions can reduce performance of the machine if the hydraulic oil temperature does not reach its optimum range.

It is recommended to use the hydraulic oil according to weather condition. Refer to the table below.

Environmental conditions	SAE Viscosity grade
Ambient temperature between - 15°C (5°F) and + 40°C (+ 104°F)	HV 46
Ambient temperature between - 20°C (- 4°F) and + 35°C (+ 95°F)	HV 32
Ambient temperature between 0°C (+ 32°F) and + 40°C (+ 104°F)	HV 68

N.B.-:IT IS RECOMMENDED TO REPLACE LOW TEMPERATURE OIL AS THE AMBIENT TEMPERATURE REACHES + 15°C (59°F). IT IS NOT ADVISABLE TO MIX OILS OF DIFFERENT BRANDS OR TYPES.

7 - Battery care and maintenance



7.1 - BATTERY RECHARGE

7.1.1 - On-board charger

The on-board charger is used to charge the semi-drive batteries. The charger's power is 750W-1000W and the maximum intensity is 10A for 220V - 240V and 110V networks. Battery charging starts as soon as it is connected via the mains supply.

N.B.-:NO MOVEMENTS ARE ALLOWED DURING BATTERIES CHARGING CYCLE AND WHILE CONNECTED TO AN EXTERNAL POWER OUTLET.

D - Operation instructions

		
Battery charger	36V / 35A	36V / 27A
Electric power supply	190 - 265 Vac / 50Hz / 10A	85 - 265 Vac / 50-60Hz / 8A max
Battery voltage	24V	
Charging time	10h	

Locations

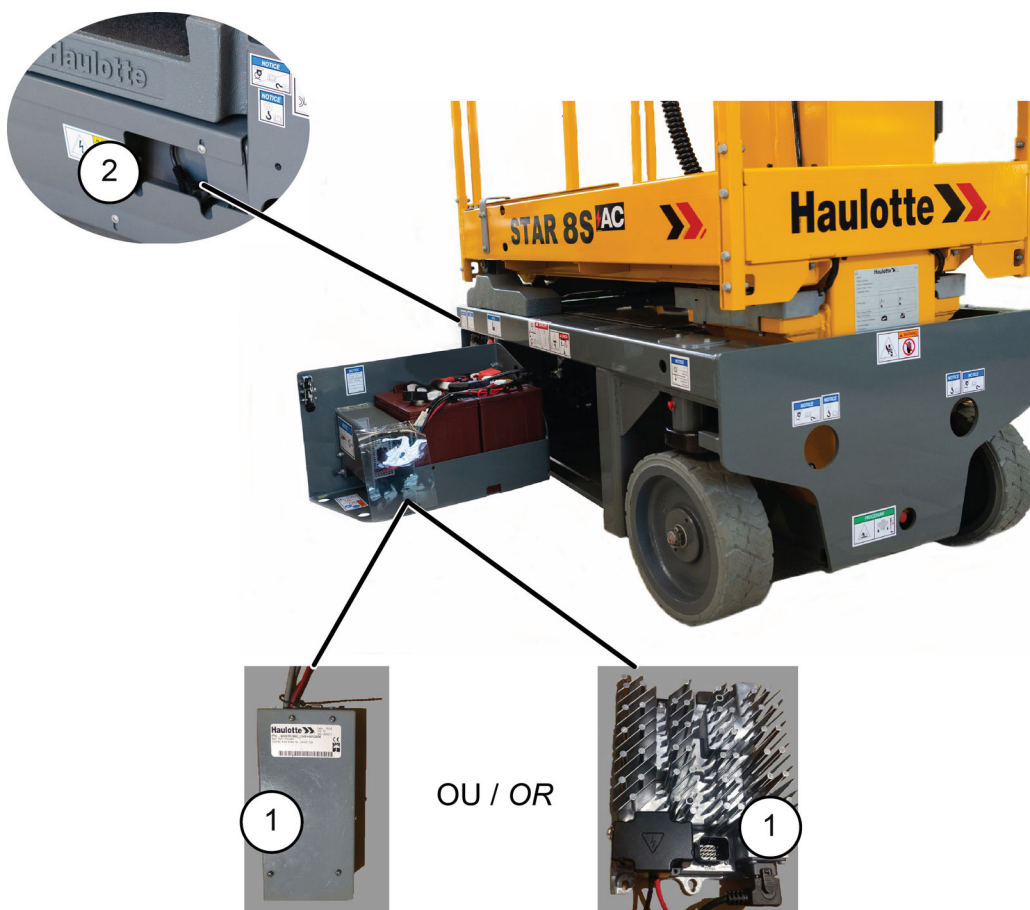

OU / OR

Marking	Description
1	On-board charger
2	Battery charger mains cable



Never replace the charging cable without written permission from HAULOTTE®.

D - Operation instructions

7.1.2 - Battery charging



- Do not use an external charger or jump the batteries.
- Ensure the mains supply is compatible :
- Do not use a cable reel with the cable wound up.
- The socket must be able to deliver a current of 10 A.

Duration of charge cycle :





- 10 hours approximately, on 220 - 240 V AC network.

The charge cycle stops automatically when charging is complete.

It can take up to 24 hours for a full charge if the battery levels are very low (Charge status less than 5 %).

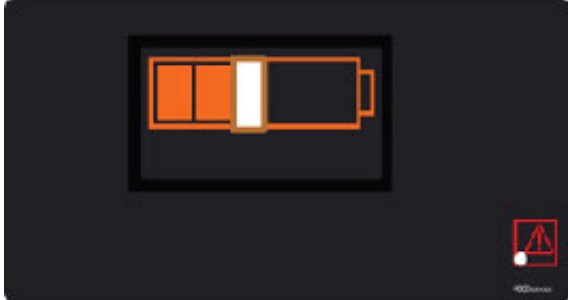
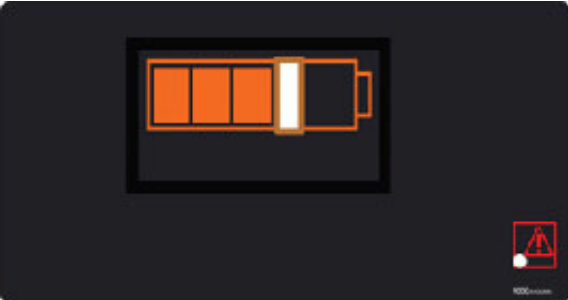
Internal parameter update		
Charging is going to start		
The first segment flashes		Charge from 0 % to 20 %
The second segment flashes		Charge from 20 % to 40 %

D - Operation instructions

<p>The third segment flashes</p>		<p>Charge from 40 % to 60 %</p>
<p>The fourth segment flashes</p>		<p>Charge from 60 % to 80 %</p>
<p>The fifth segment flashes</p>		<p>Charge from 80 % to 100 %</p>
<p>Battery equalisation</p>		<p>Leave the batteries on charge(3h)</p>
<p>Charging is complete</p>		<p>Unplug the charging cable from the machine</p>

A

B

C

D

E

F

G

H

I

D - Operation instructions

7.2 - BATTERY CARE AND MAINTENANCE

7.2.1 - Filling batteries

The procedure described below only applies to open lead acid batteries. 6 V open lead-acid battery blocks are composed of 3 2 V single cells connected together in series. The cells are immersed in an electrolyte composed of 1/3 sulfuric acid and 2/3 deionized water.



The batteries must **ONLY** be filled after charging them fully. Failure to comply with these instructions may lead to the electrolyte overflowing, etc...



The batteries **MUST** be filled when necessary or the batteries may be irreparably damaged. The lead plates oxidize in the air. They must always be covered with electrolyte.



The water level in the batteries cannot be topped up if the temperature is lower than 0° as the distilled or deionized water freezes in the centralized filling system.

D - Operation instructions

7.2.1.1 - Procedure to fill the batteries manually – Option

Single-Point Watering System

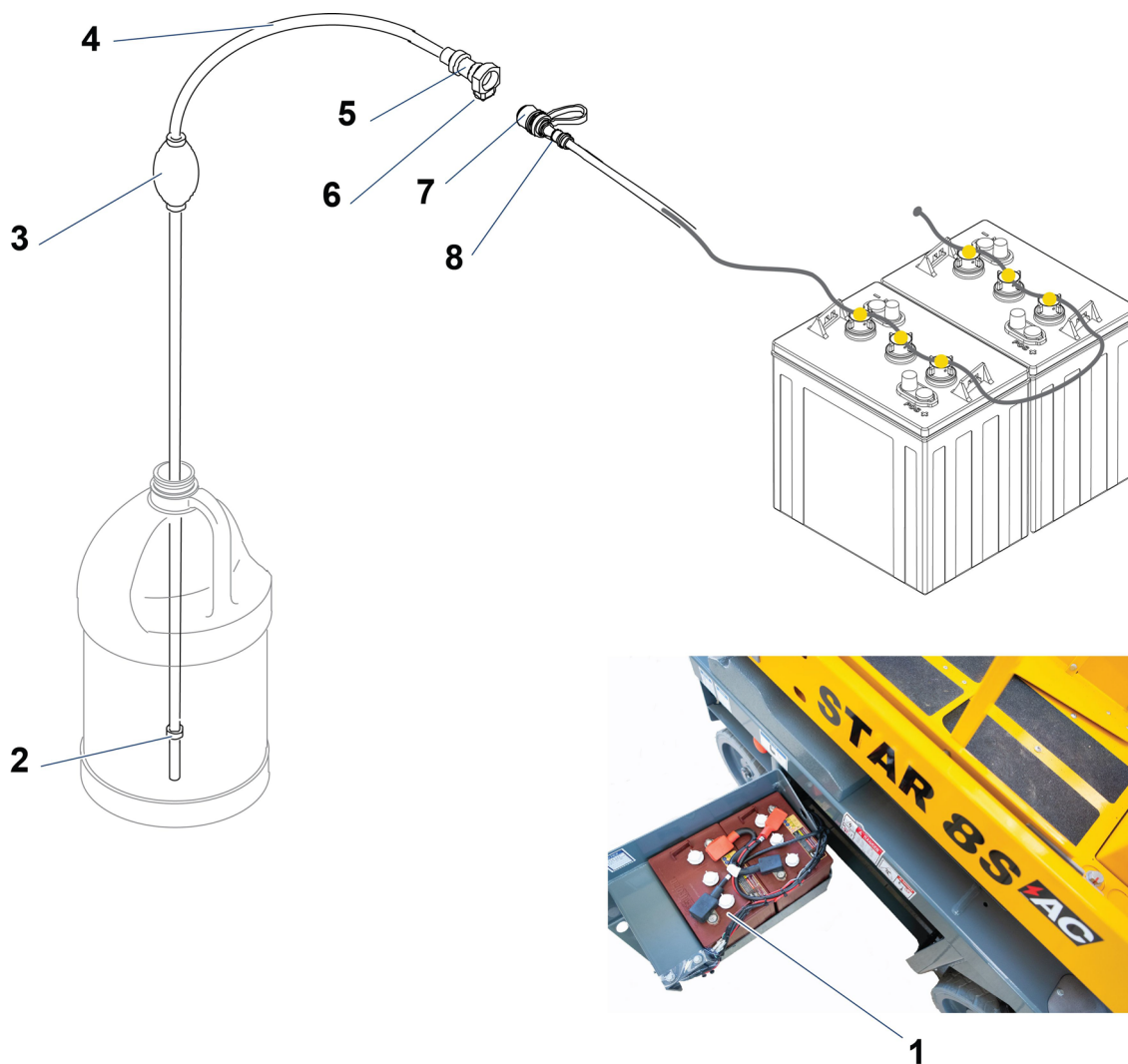

Marking	Description
1	Battery
2	Filtered intake
3	Hand pump
4	Hose
5	Female adapter
6	Push-button
7	Dust cover
8	Male adapter

N.B.:-COMPLETELY CHARGE THE BATTERIES BEFORE CONNECTING THE DISTILLED-WATER-FILLING UNIT.

D - Operation instructions

Procedure :

1. Launch a full charge of the battery and check the charge indicator.
2. Disconnect the batteries charger and put back the plug in its housing.

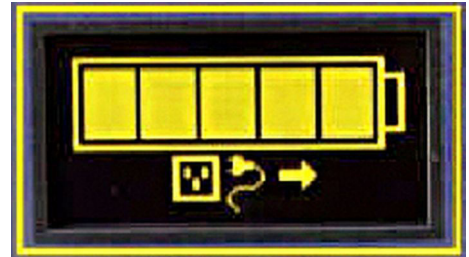

Levelling of the elements should always be done after charging the batteries. Watering a battery before charge (or with a low charge level) can lead to boil-over, resulting in potential bodily injury and potential damage to the watering system and the battery.

3. Open the battery compartment.



4. Immerse the filtered inlet (2) of the transparent hose (4) fitted with a hand pump (3) in a demineralized water canister (Supplied with the machine).
5. Press the hand pump (3) to prime it until the water rises in the hose (4)
6. Once the hand pump (3) is primed, remove the male connector (8) cap (7) from the black supply tube assembly
7. Connect the female connector (5) quick-hitch from the centralized filling system, including the hand-pump, to the male connector (8).
8. Press firmly on the hand pump to bring the distilled water to the batteries (1).
9. When the bulb (3) becomes resistant, this means that all the battery cells are filled appropriately.
10. Then uncouple the female connector (5) from the male connector (8) filling tube by pressing on the yellow button (6), then replace the cap (7) on the machine hose.
11. Close the battery compartment again.

D - Operation instructions

7.2.1.2 - Procedure to fill the batteries automatically – Option

1. Open the battery compartment.
2. Open the cap.
3. Fill the can with demineralized water.
4. Correctly close the plug and battery compartment.
5. Fully recharge the batteries in order to restart an automatic filling or activate the automatic filling from the Activ'Screen of the ground control box.



7.2.2 - Desulfation charge

Normal battery use leads to sulfation of the lead plates during discharge (Formation of lead sulfate). Recharging the battery dissolves the lead sulfate. The plates are desulfated.

Moreover, sulfation also appears if the battery self-discharges during storage in a low state-of-charge (< 70%).

As the battery ages, the lead sulfate may become harder and harder and increasingly difficult to eliminate by normal charging. This leads to a loss of autonomy. The desulfation charge is a way of regenerating the battery.



To improve the efficiency of the desulfation charge, you are advised to launch it for a battery discharged to a state-of-charge less than 30%.

Procedure :

- Go to the machine set-up menu → 3.3 Machine config → 3.3.1 Option setting → Desulfation charge.

D - Operation instructions

Desulfation charge



- The option is active and will be implemented during the next mains charge.
- Charging time is increased up to 72 h.
- For high efficiency in this charging mode, the batteries must be below 30%.

7.3 - OPTIMISE BATTERY LIFE

To optimize battery performance and life-time, you are advised to follow the recommendations below :

- Carry out regular battery maintenance as described.
- Do not store the machine discharged (Duration greater than 72 hours).
- Carry out full charges regularly.
- Do not keep a machine in a state-of-charge less than 70% for no useful purpose.



- **A full recharge of the batteries is recommended every 30 days that the machine is used.**

D- Operation instructions

Keep the top of the batteries clean and dry. Incorrect connection or corrosion may cause a high loss of power.

	Full charge	Filling control	Desulfation charge
In use			
As soon as possible	X		
If state-of-charge < 50% at the end of a working day	X		
Every 30 days of use	X		
Before placing in storage	X		
1 time a week	X	X	
1 time every 2 weeks		X	
1 time a month		X	
1 time every 6 months			X
In storage			
1 time a month	X		



The battery's water consumption depends on its use. You are advised to check the water level 1 time a week.

A

B

C

D

E

F

G

H

I

E - General Specifications

1 - Machine dimensions

Stowed / Transport position : Configuration that takes the minimum floor space necessary for storage and / or delivery of the machine - Access position.

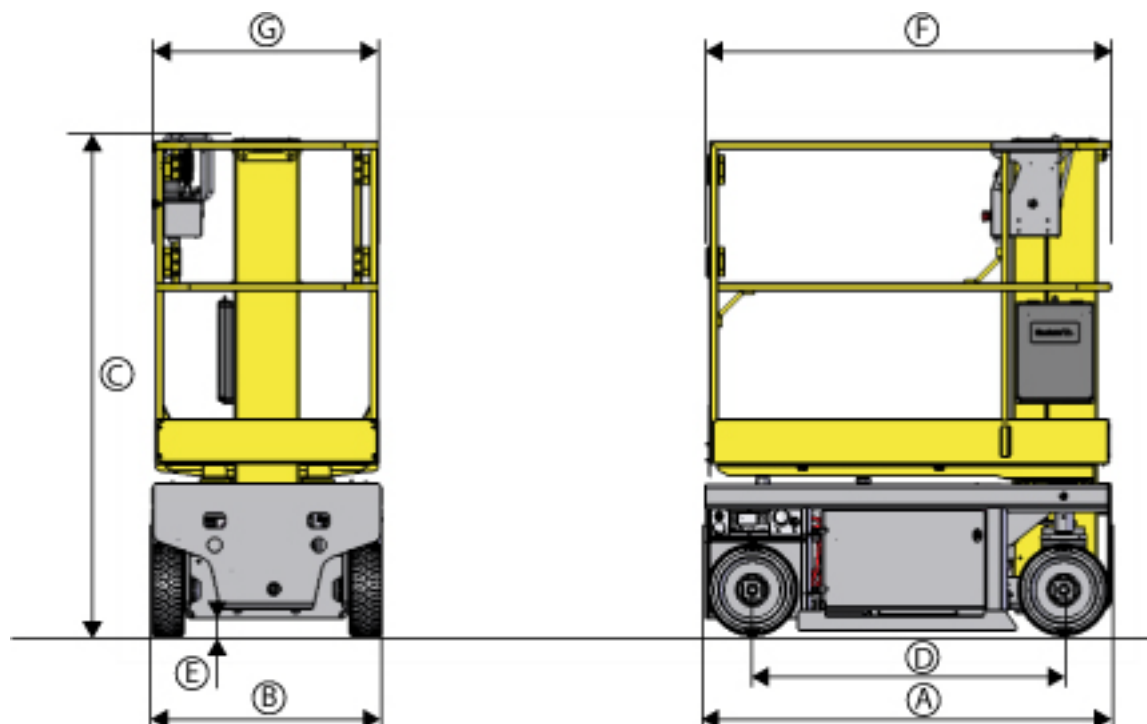

Machine		STAR 8S - STAR 20 with platform extension	
Marking	Specifications - Dimensions	SI	Imp.
A	Overall length of machine	1,40 m	4 ft 7 in
B	Overall width of machine	0,79 m	2 ft 7 in
C	Overall height of machine	1,980 m	6 ft 6 in
D	Wheel base	1,08 m	3 ft 7 in
E	Ground clearance - Pothole mechanism deployed with platform raised	1,6 cm	1 in
	Ground clearance - Pothole mechanism retracted with platform fully lowered	6 cm	3 in
F X G	Platform dimensions	1,38 m x 0,77 m	4 ft 6 in x 2 ft 6 in
	Platform extended dimensions	1,78 m x 0,77 m	5 ft 10 in x 2 ft 6 in

E - General Specifications

2 - Major component masses

N.B.-:-MASSES MEASURED WITH EMPTY TANKS.

Component	STAR 8S - STAR 20 with platform extension	
	SI	Imp.
Frame assembly mass	369 kg	814 lbs
Counterweight mass	155 kg	342 lbs
Battery mass	150 kg	331 lbs
Wheel mass	72 kg	159 lbs
Platform assembly mass	110 kg	243 lbs
Mast assembly mass	370 kg	816 lbs

3 - Acoustics and vibrations

The acoustics and vibrations specifications are based upon the following conditions :

- The airborne noise emissions at workstation are determined per European Directive 2006/42/CE.
- The guaranteed sound power level LWA (displayed on the product) is determined per European Directive 2000/14/CE.
- The vibrations transmitted by the machinery to the hand/arm system and to the whole body are determined per European Directive 2006/42/CE.

Specifications

Sound pressure level at workstation	The measured sound pressure is below 70 dBA
Vibrations hand/arm	Vibration transmitted by this MEWP to the hand-arm does not exceed 2,5 m/s ² (98,4 in/s ²)
Vibrations whole body	Vibration transmitted by this MEWP to the whole body does not exceed 0,5 m/s ² (19,6 in/s ²)

4 - Wheel/Tire assembly

4.1 - TECHNICAL SPECIFICATIONS

Component	Standard wheel
Reference number	Solideal
Type	Solid tires/tyres
Wheel mass	19 kg - 42 lbs
Size	318 mm / 108 mm (12,52 in/ 4,25 in)
Torque	250 Nm (184 ft lbs)

E- General Specifications

4.2 - INSPECTION AND MAINTENANCE

Replace the wheels and the tires if any of the following conditions exist :

- Presence of cracks, damage, deformation or other faults on the hub
- Damage to the tire :
 - Cut or hole > 3 cm (2 in) in the rubber side wall.
 - Blister or pronounced lump on the external and lateral wall.
- Damaged wheel stud.
- Damage or wear on the side wall to the extent that the reinforcing wire is visible.
- Consistent wear of the ground contact surface greater than 25%

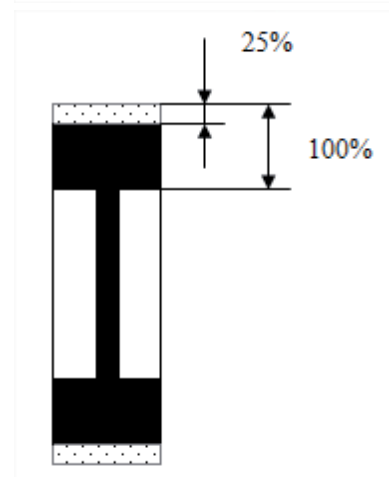
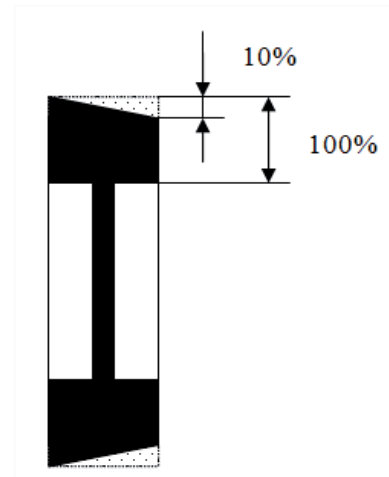

Tires and rims are critical components for the stability of the machine. For safety reasons :

- Use only HAULOTTE® spare parts according to the technical characteristics of the machine. Refer to the spare parts catalog.
- Do not replace factory-installed tires with tires of different specifications or ply rating.
- Never replace solid tire with a pneumatic (air filled) tire.

E- General Specifications

4.2.1 - Procedure of replacement

- Slightly lift the machine using a forklift.
- Place a wooden spacer under the frame to support the machine after lifting off the ground.

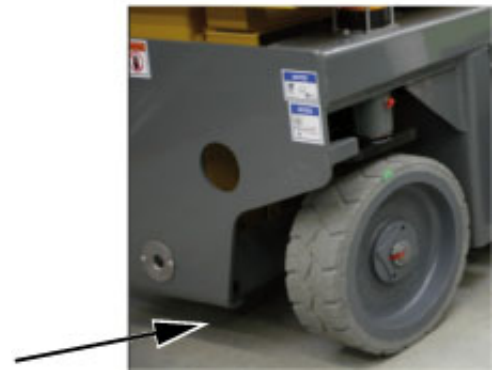

- Straighten the bent tooth of the washer which restricts the nut rotation. Use a screwdriver and a hammer.



- Use the locknut socket TMFS5 to loosen the nut.
- Remove the nut and the washer.
- Remove the wheel (use an extractor if necessary).



E- General Specifications

Reassembly of the wheel

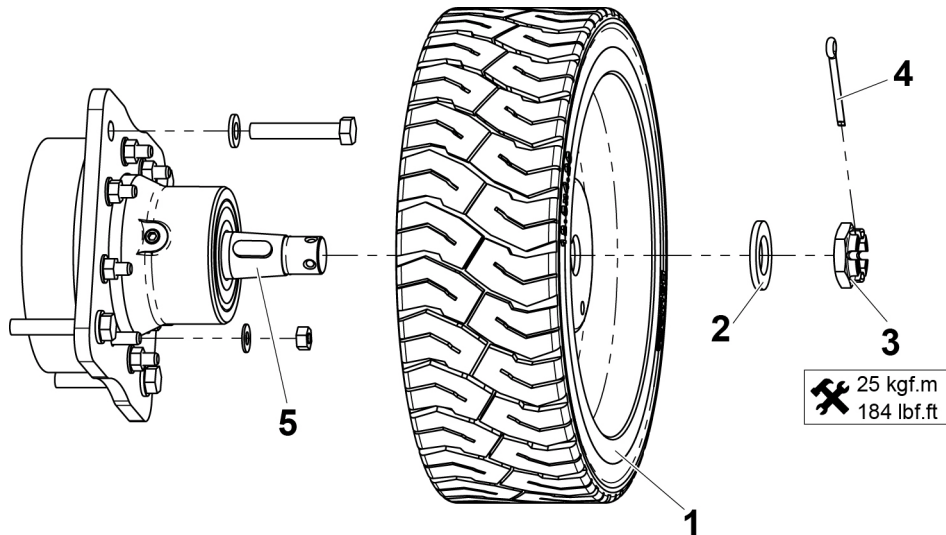

Marking	Description
1	Wheel
2	Washer
3	Nut
4	Pin
5	Motor shaft

- Use a new flat washer (2700500110).

E- General Specifications

- Use a new nut (4000503700).
 1. Check that the shaft key is well positioned in the motor shaft.
 2. Mount the wheel on the motor shaft.
 3. Install the washer first then the nut.
 4. Tighten the wheel nut to the recommended torque : 250 Nm (184 ft.lbs).
 5. Add tightening until a groove of the nut is in coincidence with one hole of the shaft of the motoreducer.
 6. Insert the pin (2352101250) into its seating.
 7. Bend over the cotter pin legs to secure the nut.



F - Maintenance

1 - General

As an owner and/or operator of Haulotte equipment, your Safety is of utmost importance to HAULOTTE®, which is why HAULOTTE® places such a high priority on product safety.

INSPECTIONS are not only required by HAULOTTE®, but may also be required by industry standards and/or local regulations.

To ensure your equipment continues to achieve the level of performance set in the factory, it is important to maintain it regularly. We remind you that it is strictly forbidden to make any modifications. Regular and timely inspections will reduce equipment down time as well as prevent possible injury.

N.B.-:DO NOT OPERATE UNLESS YOU ARE FAMILIAR AND TRAINED IN THE PRINCIPLES OF SAFE MACHINE OPERATION.

Overview :

- Walk-around inspections take only a few minutes at the beginning and end of each shift – one of the best ways to prevent mechanical problems and safety hazards.

What to Do :

- Use your senses: sight, smell, hearing and touch.

Frequency :

- Check your machine periodically during your entire workday.
- Make sure to do your inspection the same way every time.
- Complete one of these inspections at the start and end of each shift.

N.B.-:IF DAMAGE OR UNAUTHORIZED MODIFICATIONS ARE DISCOVERED, THE MACHINE MUST BE REMOVED FROM SERVICE UNTIL REPAIRS ARE MADE BY A QUALIFIED SERVICE TECHNICIAN.

It is the owner's responsibility to ensure the required maintenance as recommended by Haulotte is completed prior to the operation of the machine.

If regular maintenance is not carried out, this may :

- Void the warranty.
- Cause machine malfunction.
- Reduce machine reliability and shorten its service life.
- Jeopardize operator safety.

HAULOTTE Services® technicians are specially trained to carry out extensive repairs, interventions or adjustments on the safety systems or elements of HAULOTTE® machines. They carry genuine HAULOTTE spare parts and tools as required, and also provide fully documented reports on all work completed.

The inspection and maintenance table, identifies the role and the responsibilities of each party in periodical machine maintenance.  Section C 3 - Inspection and Functional test.

F - Maintenance

2 - Maintenance Schedule

This section provides the necessary information needed to place the machine in safe operation. In accordance with the regulations that are currently applicable, this machine is designed to have a 10 year life span in normal usage conditions. The life may be extended or reduced dependent on the severity of operating conditions, the machine condition itself and by conducting effective inspections and maintenance in addition to other external factors. There are a number of factors which can affect the design life including but not limited to, severity of operating conditions/routine maintenance which should be carried out in accordance with this manual.

Severity of operating conditions may require a reduction in time between maintenance periods. Machines that have been out of service or have not been in use for more than 3 months must undergo a periodic inspection before the machine is put back into service.

Maintenance must be carried out by a competent company or person familiar with mechanical procedures.

Maintenance operations performed must be recorded in a register / log book of the machine.

3 - Inspection program

3.1 - GENERAL PROGRAM

The machine must be inspected on a regular basis at intervals of no less than once 1 per year. The purpose of the inspection is to detect any defect which could lead to an accident during routine use of the machine. Local standards and regulations may require more frequent inspections.

HAULOTTE® requires Reinforced and Major Inspections to be carried out on the product to extend its service life.

Inspections must be carried out by a competent company or person.

The inspection results must be recorded in the safety register or machine log book controlled and overseen by the company manager. This register or machine log book and the list of competent repair persons must be made available to the government work inspector and HAULOTTE Services®.

When	Responsible	Stakeholder	What
Before sale	Owner (or renter)	Competent technician or qualified technician HAULOTTE Services®	Periodic inspection
Before rent	Owner (or renter)	Competent technician or qualified technician HAULOTTE Services®	Daily inspection
Before use or every change of user	User	User	
Annually (1 year)	Owner (or renter)	Competent technician or qualified technician HAULOTTE Services®	Periodic inspection
5 years	Owner (or renter)	Qualified technician HAULOTTE Services®	Reinforced inspection
10 years	Owner (or renter)	Qualified technician HAULOTTE Services®	Major inspection

F - Maintenance

3.2 - DAILY INSPECTION

The Daily inspection includes a visual inspection, operational checks and testing of the safety systems. This must be conducted by the operator before using the machine.

This inspection is the responsibility of the user. Refer to  Section C 3.1 - Daily inspection.

3.3 - PERIODIC INSPECTION

The Periodic inspection is a thorough evaluation of the operation and safety features of the machine.

It must be conducted before the sale / resale of the machine and/or at least once every year.

Local regulations may have specific requirements on frequency, and content of inspections.

The severity of operating conditions may require frequent inspections.

This inspection is the responsibility of the owner, and inspections must be carried out by a competent company or person.

This inspection is in addition to the daily inspection.

This inspection should also be conducted after :

- Extensive dismantling and reassembly of major components.
- Repairs involving the machine's essential components.
- Any accident causing stress to the machine.

3.4 - REINFORCED INSPECTION

The Reinforced inspection is a thorough evaluation of the machine's structural components, to ensure proper functionality of the machine.

This evaluation must occur at a frequency of 5000 hours or every 5 years.

This inspection is the responsibility of the owner, and it must be conducted by a HAULOTTE Services® technician or by a competent company or person.

This inspection includes :

- Daily inspection
- Periodic inspection

N.B.-:REFER TO THE MAINTENANCE MANUAL FOR DETAILS.

A

B

C

D

E

F

G

H

I

F - Maintenance

3.5 - MAJOR INSPECTION

The Major inspection is a thorough evaluation of the machine's integrity and proper functioning; after a normal service life of 10 years.

This evaluation must take place after 10 years of operation and then repeated every 5 years thereafter.

The severity of operating conditions may require frequent inspections.

This inspection is the responsibility of the owner, and it must be conducted by a HAULOTTE Services® technician or by a competent company or person.

This inspection includes :

- Daily inspection
- Periodic inspection
- Reinforced inspection

N.B.-:-REFER TO THE MAINTENANCE MANUAL FOR DETAILS.

F - Maintenance

4 - Repairs and adjustments

Extensive repairs, interventions or adjustments on the safety systems or components must be performed by a HAULOTTE Services® technician. Use original spare parts and components only.

N.B.-:HAULOTTE SERVICES® TECHNICIANS ARE TRAINED PROFESSIONALS TO PERFORM EXTENSIVE REPAIRS, INTERVENTIONS AND ADJUSTMENTS ON THE SAFETY SYSTEMS OR COMPONENTS OF HAULOTTE® MACHINES. THE TECHNICIAN CARRIES GENUINE HAULOTTE® SPARE PARTS AND TOOLS AS REQUIRED, AND ALSO PROVIDES FULLY DOCUMENTED REPORTS ON ALL WORK COMPLETED.

HAULOTTE Services® will not take responsibility for any outcomes resulting from inferior services or repairs performed by other unauthorised personnel.

HAULOTTE® reminds that NO modifications SHALL be carried out without the written permission of HAULOTTE®.

Any unauthorised repairs/modifications will void HAULOTTE® warranty.

To check for safety campaigns, consult our website : www.haulotte.com



N.B.-:WHEN DISPOSING OR SCRAPPING THIS MACHINE, PLEASE CONSIDER APPROPRIATE METHODS OF RECYCLING. ANY ITEMS THAT REQUIRE SPECIFIC DISPOSAL ARE LISTED WITH INSTRUCTIONS IN THE MAINTENANCE MANUAL.

G- Other information

1 - Conditions of warranty

Our warranty conditions and extension contracts are now available on the websites of our sales network : www.haulotte.com







2 - Subsidiary contact information

	<p>HAULOTTE FRANCE PARC DES LUMIERES 601 RUE NICEPHORE NIEPCE 69800 SAINT-PIERRE TECHNICAL Department: +33 (0)820 200 089 SPARE PARTS : +33 (0)820 205 344 FAX : +33 (0)4 72 88 01 43 E-mail : haulottefrance@haulotte.com www.haulotte.fr</p>		<p>HAULOTTE ITALIA VIA LOMBARZIA 15 20098 SAN GIULIANO MILANESE (MI) TEL: +39 02 98 97 01 FAX: +39 02 9897 01 25 E-mail : haulotteitalia@haulotte.com www.haulotte.it</p>		<p>HAULOTTE INDIA Unit No. 1205, 12th floor, Bhumiraj Costarica, Plot No. 1&2, Sector 18, Palm Beach Road, Sanpada, Navi Mumbai- 400 705 Maharashtra, INDIA Tel. : +91 22 66739531 to 35 E-mail : hligindia@haulotte.com www.haulotte.in</p>
	<p>HAULOTTE HUBARBEITSBÜHNEN GmbH Ehrenkirchener Strasse 2 D-79427 ESCHBACH TEL : +49 (0) 7634 50 67 - 0 FAX : +49 (0) 7634 50 67 - 119 E-mail : adv-gmbh@haulotte.com www.haulotte.de</p>		<p>HAULOTTE VOSTOK 61A, bld.1, RYABINOVAYA STREET 121471 MOSCOW RUSSIA TEL/FAX : +7 495 221 53 02 / 03 E-mail : salesrus@haulotte.com www.haulottevostok.ru</p>		<p>HAULOTTE DO BRASIL Av. Alameda Caiapós, 589 CEP: 06460-110 – TAMBORÉ BARUERI – SAO PAULO – BRASIL TEL : +55 11 4196 4300 FAX : +55 11 4196 4316 E-mail : haulottebrasil@haulotte.com www.haulotte.com.br</p>
	<p>HAULOTTE IBERICA C/ARGENTINA Nº 13 - P.I. LA GARENA 28806 ALCALA DE HENARES MADRID TEL : +34 902 886 455 TEL SAT : +34 902 886 444 FAX : +34 911 341 844 E-mail : iberica@haulotte.com www.haulotte.es</p>		<p>HAULOTTE POLSKA Sp. Z o.o. UL. GRANICZNA 22 05-090 RASZYN - JANKI TEL : +48 22 720 08 80 FAX : +48 22 720 35 06 E-mail : E-mail : haulottepolska@haulotte.com www.haulotte.pl</p>		<p>HAULOTTE MÉXICO, S.A. de C.V. Calle 40 SUR ESQUINA 13 ESTE No. S/N Colonia CIVAC, JUITEPEC, MORELOS CP 62578 México TEL : +52 77 7321 7923 FAX : +52 77 7516 8234 E-mail : haulotte.mexico@haulotte.com www.haulotte.com.mx</p>
	<p>HAULOTTE in JAPAN SBJ ShinOsaka BLDG 3F 4-6-5 Nishinakajima Yodogawa-ku, Osaka, JAPAN, Post Code: 532-0011 TEL : +81 6 6795 9008 FAX : +81 6 6795 9009 www.haulotte.com</p>		<p>HAULOTTE SINGAPORE Pte Ltd. No.26 CHANGI NORTH WAY, SINGAPORE 498812 Parts and service Hotline: +65 6546 6150 FAX : +65 6536 3969 E-mail : haulotteasia@haulotte.com www.haulotte.sg</p>		<p>HAULOTTE MIDDLE EAST FZE PO BOX 293881 Dubai Airport Free Zone DUBAÏ United Arab Emirates TEL : +971 (0)4 299 77 35 FAX : +971 (0) 4 299 60 28 E-mail : haulottemiddle-east@haulotte.com www.haulotte.ae</p>
	<p>HAULOTTE SCANDINAVIA AB Taljegårdsgatan 12 431 53 Mölndal SWEDEN TEL : +46 31 744 32 90 FAX : +46 31 744 32 99 E-mail : info@se.haulotte.com spares@se.haulotte.com www.haulotte.se</p>		<p>HAULOTTE TRADING (SHANGHAI) Co. Ltd. #7 WORKSHOP No 191 HUA JIN ROAD MIN HANG DISTRICT SHANGHAI 201108 CHINA TEL : +86 21 6442 6610 FAX : +86 21 6442 6619 E-mail : haulotteshanghai@haulotte.com www.haulotte.cn</p>		<p>HAULOTTE ARGENTINA Ruta Panamericana Km. 34,300 (Ramal A Escobar) 1615 Gran Bourg (Provincia de Buenos Aires) Argentina TEL : +54 33 27 445991 FAX : +54 33 27 452191 E-mail : haulotteargentina@haulotte.com www.haulotte.com.ar</p>
	<p>HAULOTTE UK Ltd 1 Gravely Way Four Ashes Wolverhampton WV10 7GW ENGLAND TEL : +44 (0)1216 199753 FAX : +44 (0)1952 292758 E-mail : salesuk@haulotte.com www.haulotte.co.uk</p>		<p>HAULOTTE GROUP / BILJAX 125 TAYLOR PARKWAY ARCHBOLD, OH 43502 – USA TEL : +1 419 445 8915 FAX : +1 419 445 0367 Toll free : +1 800 537 0540 E-mail : sales@us.haulotte.com www.haulotte-usa.com</p>		<p>HAULOTTE NORTH AMERICA 3409 Chandler Creek Rd. VIRGINIA BEACH, VA 23453 – USA TEL : +1 757 689 2146 FAX : +1 757 689 2175 Toll free : +1 800 537 0540 E-mail : sales@us.haulotte.com www.haulotte-usa.com</p>
	<p>HAULOTTE NETHERLANDS BV Koopvaardijweg 26 4906 CV OOSTERHOUT - Nederland TEL : +31 (0) 162 670 707 FAX : +31 (0) 162 670 710 E-mail : info@haulotte.nl www.haulotte.nl</p>		<p>HAULOTTE AUSTRALIA PTY Ltd 51 Port Link Drive DANDENONG – VIC – 3175 TEN : 1 300 207 683 FAX : +61 (0)3 9792 1011 E-mail : sales@haulotte.com.au www.haulotte.com.au</p>		<p>HAULOTTE CHILE Panamerica Norte Altura Km 21,5 Colina (Cruce c/Lo Pinto) Santiago (RM) TEL : + 562 2 3727630 E-mail : haulotte-chile@haulotte.com www.haulotte-chile.com</p>

G- Other information

2.1 - CALIFORNIA WARNING

For the US destined machines (ANSI and CSA standards)

<p>CALIFORNIA</p> <p> Proposition 65 Warning</p> <p>Operating, servicing and maintaining a passenger vehicle or off-road vehicle can expose you to chemicals including engine exhaust, carbon monoxide, phthalates, and lead, which are known to the State of California to cause cancer and birth defects or other reproductive harm. To minimize exposure, avoid breathing exhaust, do not idle the engine except as necessary, service your vehicle in a well-ventilated area and wear gloves or wash your hands frequently when servicing your vehicle.</p> <p>For more information go to  www.P65Warnings.ca.gov/passenger-vehicle</p>
<p>CALIFORNIE</p> <p> Avertissement de la Proposition 65</p> <p>L'exploitation, l'entretien et la maintenance d'un véhicule de tourisme ou d'un véhicule tout-terrain peuvent vous exposer à des produits chimiques, y compris les gaz d'échappement, le monoxyde de carbone, les phthalates et le plomb, identifiés par l'État de Californie comme pouvant causer le cancer et des malformations congénitales ou autres effets nocifs sur la reproduction. Pour limiter toute exposition: évitez de respirer les gaz d'échappement, ne laissez pas tourner le moteur au ralenti sauf si nécessaire, faites l'entretien du véhicule dans une zone bien aérée et portez des gants ou lavez vous fréquemment les mains lors de cette opération.</p> <p>Pour de plus amples informations, consulter  www.P65Warnings.ca.gov/passenger-vehicle</p>
<p>CALIFORNIA</p> <p> Advertencia de la Proposición 65</p> <p>Operar, dar servicio y mantenimiento a un vehículo de pasajeros o vehículo todo terreno puede exponerle a químicos incluyendo gases del escape, monóxido de carbono, ftalatos y plomo, los cuales son conocidos por el Estado de California como causantes de cáncer y defectos de nacimiento u otros daños reproductivos. Para minimizar la exposición, evite respirar los gases del escape, no encienda el motor excepto si es necesario, dé servicio a su vehículo en un área bien ventilada y utilice guantes o lave sus manos frecuentemente cuando dé servicio a su vehículo.</p> <p>Para mayor información visite  www.P65Warnings.ca.gov/passenger-vehicle</p>

G- Other information

For electric (battery operated) machines

CALIFORNIA



Proposition 65 Warning

Battery posts, terminals and related accessories contain lead and lead compounds, chemicals known to the State of California to cause cancer and reproductive harm. Batteries also contain other chemicals known to the State of California to cause cancer.

WASH HANDS AFTER HANDLING.

For more information go to  www.P65Warnings.ca.gov

CALIFORNIE



Avertissement de la Proposition 65

Les batteries, les bornes et autres accessoires contiennent du plomb et des composés à base de plomb, agents chimiques identifiés par l'État de Californie comme pouvant provoquer le cancer et des effets nocifs sur la reproduction. Les batteries contiennent également d'autres agents chimiques identifiés par l'Etat de Californie comme pouvant provoquer le cancer.

SE LAVER LES MAINS APRES MANIPULATION.

Pour de plus amples informations, consulter  www.P65Warnings.ca.gov

CALIFORNIA



Advertencia de la Proposición 65

Los bornes, los terminales y los accesorios de las baterías contienen plomo y compuestos de plomo, químicos conocidos por el Estado de California como causantes de cáncer y daños reproductivos. Las baterías también contienen otros químicos conocidos por el Estado de California como causantes de cáncer.

LAVESE LAS MANOS DESPUES DE MANIPULARLOS.

Para mayor información visite  www.P65Warnings.ca.gov

H- Intervention register

1 - Intervention register

The intervention register keeps a record of maintenance and repair work carried out inside or outside the maintenance programme.

N.B.-:IN THE CASE OF A HAULOTTE SERVICES® INTERVENTION, THE QUALIFIED TECHNICIAN MUST INDICATE THE HAULOTTE SERVICES® INTERVENTION NUMBER.

Date	Type of intervention	Number of hours	Intervenor	HAULOTTE Services® intervention number

A

B

C

D

E

F

G

H

I

H- Intervention register

Date	Type of intervention	Number of hours	Intervenor	HAULOTTE Services® intervention number