



## SJ40/45 T TELESCOPIC BOOMS

### STANDARD FEATURES

- Axle based 4WD system
- "Detroit Locker" type rear differential and limited slip front differential
- Oscillating axle
- Drivable at full height
- 50% Gradeability
- Diesel or dual fuel engine
- Swing out engine tray
- Swing up cowlings
- Modular platform railing system
- Tri-entry sliding mid rails
- 110V AC outlet on platform with GFI
- Direction sensing drive and steer controls
- Proportional controls
- Relay based control system
- Color coded and numbered wiring
- 360° continuous turret rotation
- Hourmeter
- Operator horn
- All motion alarm
- Tie down/lifting lugs
- Wet disc SAHR brakes (rear axle)
- 12 x 16.5 grip lug air-filled tires
- Telematics ready

\* Standard lead times may be increased when optional equipment is added, consult factory.

† Capacities, and machine weights may differ when options are added.

### ACCESSORIES AND OPTIONS

- 36 x 72" Platform
- 3.5 kW generator (Includes hydraulic oil cooler)
- Welder ready package (Includes 12 kW generator, hydraulic oil cooler, 3-phase power connection in platform, and welder mount)
- Welder package (Includes 12 kW generator, hydraulic oil cooler, 3-phase power connection in platform, welder mount, and Lincoln V275-S welder)
- Cold weather start kit (Includes cold start engine oil, battery blanket, and hydraulic tank heater)
- Arctic weather package (Includes arctic engine oil, battery blanket, hydraulic tank heater, block heater, arctic hydraulic oil, arctic platform rotator and arctic gear oil in the axles and swing drive. Glow plugs, arctic hydraulic hoses (all), and oversized foot switch cover are also included (standard equipment).
- Hydraulic oil cooler
- Side gate
- Flashing light
- 1/2" airline to platform
- Positive air shut-off valve
- Non destructive testing
- Glazier kit
- Control box cover
- Auxiliary top rail (36 x 96" platform only)
- Warranty Options (3 year or 5 year plans available)

### TIRE OPTIONS

- Grip lug foam-filled tires
- High flotation air-filled tires

# SJ40/45 T TELESCOPIC BOOMS

Dimensions	SJ40 T	SJ45 T
Work Height	46'7" (14.20 m)	51'2" (15.60 m)
Platform Height	40'7" (12.37 m)	45'2" (13.77 m)
Horizontal Reach	34' (10.36 m)	39'9" (12.12 m)
<b>A</b> Platform Size	36" x 96" (0.91 x 2.44 m)	36" x 96" (0.91 x 2.44 m)
<b>B</b> Stowed Width	90" (2.29 m)	90" (2.29 m)
<b>C</b> Tailswing	37" (0.94 m)	37" (0.94 m)
<b>D</b> Stowed Height	94" (2.39 m)	94" (2.39 m)
<b>E</b> Stowed Length	25'5" (7.74 m)	28'10" (8.79 m)
<b>F</b> Wheelbase	96" (2.44 m)	96" (2.44 m)
<b>G</b> Ground Clearance	11" (0.28 m)	11" (0.28 m)

Specifications	SJ40 T	SJ45 T
Rotation	360° Continuous	
Platform Rotation	170°	170°
Jib Length	-	5' (1.5 m)
Jib Range +/-	-	+65° / -60°
Weight	13,960 lbs (6,332 kg)	14,830 lbs (6,727 kg)
Gradeability	50%	50%
Turning Radius (Inside)	84" (2.13 m)	84" (2.13 m)
Turning Radius (Outside)	198" (5.03 m)	198" (5.03 m)
Axle Oscillation	5" (12.70 cm)	5" (12.70 cm)
Drive Speed (High speed)	4.5 mph (7.2 km/h)	4.5 mph (7.2 km/h)
Capacity	650 lbs (295 kg)	500 lbs (227 kg)
Local Floor Load ( With Rated Load)	130 psi (896 kPa)	135 psi (931 kPa)
Overall Floor Load (With Rated Load)	193 psf (9.24 kPa)	200 psf (9.58 kPa)
Maximum # of Persons	2	2
Tire Type	Air Filled	Air Filled
Tire Size	12 x 16.5	12 x 16.5
Diesel Engine	48 HP	
Dual Fuel Engine	82 HP	
Fuel Tank Capacity	45 gallon (170 L)	
Hydraulic Reservoir	59 gallon (223 L)	

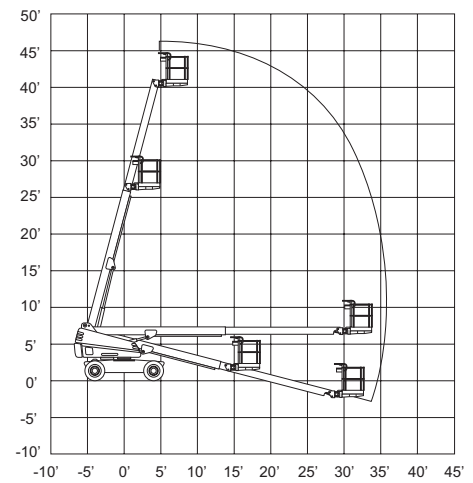
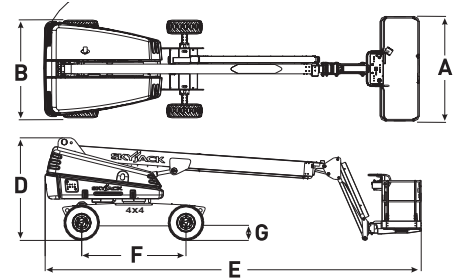

SJ40 T Work Height

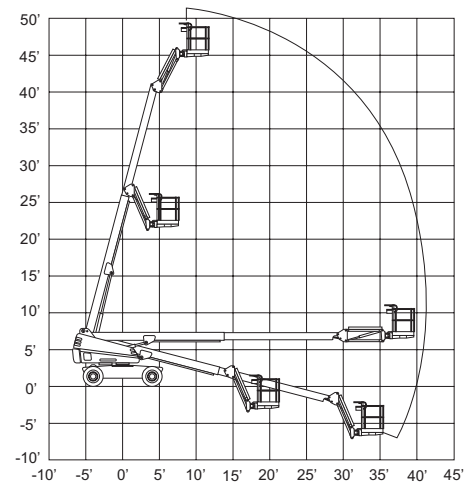

SJ45 T Work Height

**Skyjack Head Office**  
 55 Campbell Rd. Guelph, ON Canada N1H 1B9  
 Sales Inquiries: 1-877-755-4387 (1-877-SJLIFTS)  
 Main Switchboard: 1-800-265-2738  
 Phone: 519-837-0888  
 Fax: 519-837-8104  
 Email: skyjack@skyjack.com  
 www.skyjack.com

This brochure is for illustrative purpose only and based on the latest information at the time of printing. Skyjack Inc. reserves the right to make changes at any time, without notice, to specifications, standard and optional equipment. Consult the Operating Maintenance and Parts Manuals for proper procedures. Work platforms have been tested to comply with ANSI and CSA standards as interpreted by Skyjack Inc.

