

For online reference and to download the manuals for your machines , go to:-

<https://www.e-technical-information.com>

or, scan the QR Code below



OPERATOR'S MANUAL

SIGMA 16 - SIGMA 46 - SIGMA 16 PRO - SIGMA 46 PRO

Touch screen display

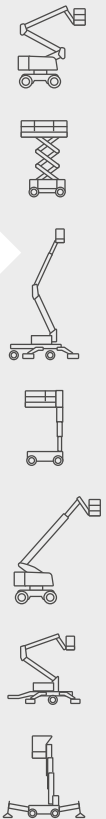

A-Foreword

1	Foreword.....	3
2	Responsibilities.....	4
2.1	Owner's responsibility.....	4
2.2	Employer's responsibility.....	4
2.3	Trainer's responsibility.....	4
2.4	Operator's responsibility.....	4
3	Safety.....	5
3.1	Safety instructions.....	5
4	Safety inquiries.....	12
5	Incident notification.....	13
6	Compliance.....	14
6.1	Product modification.....	14
6.2	Product specifications.....	14
6.3	Change of Ownership Notification.....	14
6.4	Declaration of conformity.....	16

B-Familiarization

1	General safety.....	3
1.1	Intended use.....	3
1.2	Decal content.....	3
1.3	Level of severity.....	4
1.4	Symbols legend and definitions.....	5
1.5	Symbols and colors.....	7
2	Models description.....	8
3	Primary machine components.....	9
3.1	Layout.....	9
3.2	Ground control box - Service / Emergency station.....	11
3.3	Platform control box - Main station.....	30
4	Performance Specifications.....	35
4.1	Technical characteristics.....	35
4.2	Working area / Range of motion.....	43
5	Decals and markings locations.....	45

C-Pre-operation inspection

1	Recommendations.....	3
2	Working area assessment.....	4
3	Inspection and Functional test.....	5
3.1	Daily inspection.....	5
4	Safety functional checks.....	9
4.1	Emergency Stop button check.....	9
4.2	Activation of controls.....	9
4.3	Fault detector.....	10
4.4	Overload sensing system.....	11
4.5	Slope warning device.....	11

Contents

4.6	Travel speed limitation.....	12
4.7	On-board electronics.....	12
4.8	Braking test.....	12
4.9	Overload test.....	13

D-Operation instructions

1	Operation.....	3
1.1	Introduction.....	3
1.2	Major description.....	3
1.3	Operation from the ground control box (Service / Emergency station).....	3
1.4	Operation from the platform control box (Main station).....	4
2	Ground control box - Service / Emergency station.....	6
2.1	To start and stop the machine.....	6
2.2	Movement control.....	6
2.3	Additional controls.....	8
3	Platform control box - Main station.....	9
3.1	To start and stop the machine.....	9
3.2	Drive and steer control.....	9
3.3	Movement control.....	10
3.4	Additional controls.....	12
4	Rescue and emergency procedures.....	14
4.1	Main power supply failure.....	14
4.2	To rescue operator in platform.....	15
4.3	Operation of overriding system from ground control box.....	15
5	Transportation.....	16
5.1	Transport configuration.....	16
5.2	Machine stowage for transport -SIGMA 16 - SIGMA 46 - SIGMA 16 PRO - SIGMA 46 PRO.....	16
5.3	Unloading.....	18
5.4	Towing.....	18
5.5	Storage.....	19
5.6	Lifting operation.....	20
6	Cold Weather Recommendations.....	22
6.1	Hydraulic oil.....	22
7	Battery care and maintenance.....	23
7.1	Battery recharge.....	23
7.2	Battery care and maintenance.....	26
7.3	Optimise battery life.....	29

E-General Specifications

1	Machine dimensions.....	3
2	Major component masses.....	5
3	Acoustics and vibrations.....	6
4	Wheel/Tire assembly.....	7
4.1	Technical specifications.....	7
4.2	Inspection and maintenance.....	8
5	Options.....	10

Contents

5.1	Compatibility.....	10
5.2	Advanced Access Management - Access control and usage restriction.....	10
5.3	Platform.....	22
5.4	Swing gate.....	23
5.5	Plumber's kit.....	24
5.6	Signalling cones holder.....	27
5.7	Neon tube holder.....	30
5.8	Activ' Shield Bar - Secondary crush risk reduction system (If fitted)	33

F-Maintenance

1	General.....	3
2	Maintenance Schedule.....	4
3	Inspection program.....	5
3.1	General program.....	5
3.2	Daily inspection.....	5
3.3	Periodic inspection.....	5
3.4	Reinforced inspection.....	6
3.5	Major inspection.....	6
4	Repairs and adjustments.....	7

G-Other information

1	Conditions of warranty.....	3
2	Subsidiary contact information.....	4
2.1	California warning.....	5

H-Records

1	Intervention register.....	3
---	----------------------------	---

Contents

A - Foreword

1	Foreword.....	3
2	Responsibilities.....	4
2.1	Owner's responsibility.....	4
2.2	Employer's responsibility.....	4
2.3	Trainer's responsibility.....	4
2.4	Operator's responsibility.....	4
3	Safety.....	5
3.1	Safety instructions.....	5
4	Safety inquiries.....	12
5	Incident notification.....	13
6	Compliance.....	14
6.1	Product modification.....	14
6.2	Product specifications.....	14
6.3	Change of Ownership Notification.....	14
6.4	Declaration of conformity.....	16

1 Foreword

You have just purchased a HAULOTTE® product and we would like to thank you for your business.

The aerial work platform is a device for lifting people designed and manufactured with the intent to enable users to access overhead elevated temporary workplaces with the necessary tools and equipment. All other uses or alterations/modifications to the aerial work platform must be approved by HAULOTTE®.

This manual shall be considered a permanent component of the machine and shall be kept with the aerial work platform in the designated Manual Holder, at all times.

Safe operation of this product can only be assured if you follow the operating instructions contained in this manual. To ensure the safe and appropriate use of this equipment, only trained personnel are authorised to use and carry out maintenance on the aerial work platform.

We would particularly like to draw your attention to 2 essential points:

- Comply with safety instructions.
- Use this equipment within the performance limits specified by this user manual.

With regard to the designation of our equipment, we stress that this is purely for commercial purposes and not to be confused with the technical specifications. Only the specifications in this manual should be used to study the suitability of the equipment for the intended use.

This operator's manual is specific to the HAULOTTE® products listed on the cover page of this manual.



Original language and version: Manuals in English and French are the original instructions. Manuals in other languages are translations of the original instructions.

The user manual does not replace the necessary training that is required for all of this machine's operators. HAULOTTE® has compiled this manual to assist in safe and efficient operation of the products covered in the manual.

The manual must be available to all operators and must be kept in a legible condition. Additional copies can be ordered from HAULOTTE Services®.

Stay Safe and keep working with HAULOTTE®!

For online reference and to download the manuals for your machines HAULOTTE®, go to:

<https://www.e-technical-information.com>

Or, scan the QR Code below:



2 Responsibilities

2.1 Owner's responsibility

The owner (or hirer) has the obligation to:

- To inform operators of the instructions contained in the Operator's Manual.
- Follow local regulations regarding operation of the machine.
- Replace all manuals or labels that are missing or in poor condition. Additional copies can be ordered from HAULOTTE Services®.
- To establish a preventive maintenance program in accordance with the manufacturer's recommendations, taking into account the environment and severity of use of the machine.
- To perform periodic inspections in accordance with HAULOTTE® recommendations and local regulations.

All malfunctions and problems identified during the inspection shall be corrected before the aerial work platform is returned to service.

2.2 Employer's responsibility

The employer (or plant superintendent) is required:

- To train and check the training of users.
- To authorise the trained user(s) to use the machine.
- To inform and familiarize the operator with the local regulations.
- Forbid anyone from operating the machine if:
 - Under the influence of drugs, alcohol, etc.
 - Subject to fits, convulsions, dizziness, etc.

2.3 Trainer's responsibility

- The trainer must be qualified to provide training to operators in accordance with applicable local regulations.
- The training must include all of the instructions in this manual.
- The training must be given in an obstacle-free area until the trainee is considered competent as defined by the training program undertaken.

2.4 Operator's responsibility

The operator has the obligation to:

- Read and understand the contents of this manual and familiarize himself/herself with the decals affixed on the machine.
- To inspect the machine before use according to HAULOTTE®'s recommendations..
- Inform the owner (or hirer) if the manual or any decals are missing or are not legible.
- Inform the owner (or hirer) of any machine malfunction.

Operators must ensure that the inspections have been carried out by the owner and that they can use the machine for the purpose intended by the manufacturer.



All users (driver, passenger, maintainer, transporter, etc.) must familiarise themselves with the emergency controls and machine operation in case of an emergency.

The operator has the obligation to stop using the machine in the event of malfunction or safety problems on the machine or in the work area and report the problem immediately to his/her supervisor.

3 Safety

3.1 Safety instructions

3.1.1 Incorrect use

- Do not use the machine outside of the conditions specified in this manual.
- Do not use the machine as a crane, material lift or elevator.



- Do not use the work platform as a hoisting machine (crane) by suspending a load outside of the platform.
- Do not tie the boom or platform to an adjacent fixed or mobile structure.
- Do not use/operate the machine when alone. A survey person or immediate Supervisor must be present on the ground in case of emergency.
- Do not use a faulty or poorly maintained machine. Remove defective/damaged machine from service.
- Do not climb onto the compartment covers of the machine.
- Do not replace items critical to machine stability with items of different weight or specification.
- Do not replace the wheels installed in the factory with wheels with different characteristics
- Do not alter or disable machine components that in any way affect safety and stability.
- Do not disable the safety devices.
- Do not use the machine if a label is missing or illegible.
- Do not damage, modify or hide machine labels or inscriptions.

3.1.2 Falling Hazards

N.B.-:THE GUARDRAIL IS THE MAIN PROTECTION SYSTEM AGAINST FALLS FROM THE MOBILE LIFTING PLATFORM (PEMP) .

Before commencing operation:

- Ensure that guard rails are correctly installed and secured.
- Ensure that gate or sliding bar is in its securely locked position.
- If using a machine that has a swing gate, check that the entry gate closes by itself and gate latches and locks.



- Remove oil or grease from the steps, floor, handrail and the guardrails.
- Clean the floor of the platform (no debris).

To enter or exit from the platform:

- The machine must be completely stowed (Access position) .
- Face the machine to access the opening to the platform.
- Keep 3 points of contact on the steps and the guardrail.
- Keep fingers away from moving parts near entry gate.



A - Foreword

When in the platform:

- Where personal fall protection equipment (FPE) is required by the employer, a competent authority or local regulations, we recommend using a full harness with a safety line.
- Personal fall protection equipment must only be fastened to approved fall protection anchoring points on the platform provided for this purpose.
- Refer to this decal located on the platform.
- Safety lines must never be attached to an object or structure outside of the work platform.
- Hold on securely to the guardrails.
- Always keep your feet firmly on the floor of the platform.
- Do not sit, stand, or climb on the platform guard rails.
- Do not lean on the gate or sliding bar.
- Do not lean over the guard rails or climb over them. Only work in the platform area within the guard rails.
- Do not exit the platform until it is in the completely stowed position.
- Do not use the guardrail as a means of access to climb in or out of the platform.

**3.1.3 Overturning / Tip-over Hazards****Before positioning and operating the machine:**

- Ensure that the surface is capable of supporting the machine weight including the rated capacity. Check the load bearing capacity of the supporting ground.  B 4.1 - Technical characteristics.
- Remain vigilant of driving direction reversal at the platform. Check the direction of movement with the help of the red or white arrows on the chassis and on the platform control box.
- Do not exceed the maximum rated capacity that includes the weight of both material and allowed number of occupants. Do not exceed the allowable number of occupants.
- Do not increase the working height (using extensions, ladder, etc.).
- Do not place ladders or scaffolds in the platform or against any part of this machine.
- Position loads uniformly in the centre of the work platform.
- Do not use the machine at wind speeds that are above the permissible threshold. Refer to the display on the work platform to view the permissible wind speed.
- Do not increase the surface area of the platform exposed to wind. This includes adding panels, mesh, banners. Failure to follow this instruction may lead to a loss of stability and as a result, the machine could tip over.
- Do not raise the platform or move the machine with the platform raised on a slope with a gradient greater than the machine's permissible limit.



A - Foreword

- Do not drive the machine on slopes or grades exceeding the specified limits.



- Do not replace components critical to stability with components of different weight or specification.
- Do not use the machine with material or objects hanging from the guardrail or the boom.



- Do not pull or push towards any object outside of the platform. Do not exceed the maximum allowable side force stated in the performance specifications.
- Do not use the machine to support any external structure.
- Do not use the machine to tow other machines or to drag materials.

Using the machine on a slope:



Do not drive the machine on slopes with gradients exceeding the authorised transversal and lateral limits for the machine.  B 4.1 - Technical characteristics.

WIND: the aerial work platform can be used up to the maximum wind speed indicated in the specifications in this manual. To identify the local wind speed, use the Beaufort scale below, a wind gauge or an anemometer.

N.B.:-THE BEAUFORT SCALE OF WIND FORCE IS ACCEPTED INTERNATIONALLY AND IS USED WHEN COMMUNICATING WEATHER CONDITIONS. A WIND SPEED RANGE AT 10 M (32 FT 9 IN) ABOVE FLAT, CLEAR LAND IS ASSOCIATED WITH EACH DEGREE.

Beaufort scale

Force	Meteorological description	Observed effects	m/s	km/h	mph
0	Calm	Smoke rises vertically.	0 - 0,2	0 - 1	0 - 0,62
1	Very light breeze	Smoke indicates the wind direction.	0,3 - 1,5	1 - 5	0,62 - 3,11
2	Light breeze	Wind felt on the face. Leaves rustle. Weather vanes turn.	1,6 - 3,3	6 - 11	3,72 - 6,84
3	Slight breeze	Leaves and small twigs in constant motion. Flags move slightly.	3,4 - 5,4	12 - 19	7,46 - 11,8
4	Nice breeze	Raised dust and loose papers. Small branches are moved.	5,5 - 7,9	20 - 28	12,43 - 17,4

A - Foreword

Force	Meteorological description	Observed effects	m/s	km/h	mph
5	Nice breeze	Small trees in leaf to sway. Crested wavelets form on inland waterways.	8,0 - 10,7	29 - 38	18,02 - 23,6
6	Cool wind	Large branches in motion. Power lines and chimneys 'sing'. Umbrellas used with difficulty.	10,8 - 13,8	39 - 49	24,23 - 30,45
7	Near gale	Whole trees in motion. Inconvenience felt when walking against wind.	13,9 - 17,1	50 - 61	31 - 37,9
8	Gale	Some branches break. Generally we cannot walk against the wind.	17,2 - 20,7	62 - 74	38,53 - 45,98
9	Strong gale	The wind causes slight damage to buildings. Tiles and chimney stacks are blown off.	20,8 - 24,4	75 - 88	46,60 - 54,68

3.1.4 Risk of electric shock (electrocution)



Risk of death or serious injuries.

The machine is not electrically insulated and does not provide protection from contact or proximity to electrically charged conductors.

Always position all parts of the aerial work platform, the occupants, accessories and tools at a reasonable distance from power lines to ensure that no part of the work platform accidentally comes into contact with a power line.

Apply the local regulations or those of the employer with regard to the safety distances. If this is not possible, follow the distances in the table below at a minimum:

Minimum safe approach distances

Electric voltage	Minimum safety distance	
	Mètre	Feet
0 - 300 V	Avoid contact	
300 V - 50 kV	3	10
50 - 200 kV	5	15
200 - 350 kV	6	20
350 - 500 kV	8	25
500 - 750 kV	11	35
750 - 1000 kV	14	45

A - Foreword

- Do not operate the machine when close to live power lines, consider the movement of the machine and the sway of the electric power lines particularly in windy conditions.
- Do not operate the machine during lightning, thunderstorms, snow/ice or any weather condition that could compromise operator safety.
- Do not use the machine as a ground for welding.
- Do not weld on the machine without first disconnecting the battery terminals.
- Always disconnect ground cable first.
- The machine must not be used while charging the batteries.
- When using the AC power supply, ensure it is protected with a circuit breaker and residual current device.
- Never expose the batteries or electrical components to water (high pressure washer, rain).



Keep away from the machine if it contacts energized power lines. Personnel on the ground or in the platform must not touch or operate the machine until energized power lines are shut off.



The user must not leave the platform if it comes into contact with a power line.

3.1.5 Explosion / Fire Hazards

- Always wear protective clothing and eye wear when working with batteries and power sources/systems.

N.B.: ACID IS NEUTRALIZED WITH SODIUM BICARBONATE AND WATER.



- Do not work on or operate a machine in an explosive or flammable atmosphere / environment.
- Do not touch hot components.
- Do not bridge the battery terminals with metallic objects.



- Do not service the battery in proximity of spark, open flame, lit cigarettes.
- Do not fill the fuel tank with the engine running, close to naked flames and/or while smoking.







3.1.6 Crushing / Collision Hazards



Before using the machine, mark out the machine's work and circulation area using a marking system appropriate to the task at hand and the work environment.

A - Foreword

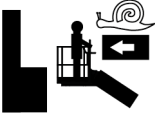
When in the platform:

- Check the work area for overhead clearance, for any obstacles besides and below the platform when raising/lowering the platform and or before driving.
- 
- 
- During movement, keep all the parts of the body inside the platform. Hold onto the guardrails on the opposite side to any surrounding structures.
 - To position machine close to a building/structure, it is recommended using the upper boom and or arms movement control functions to position, rather than driving machine closer to structure.
- 
- Warn personnel not to work, stand, or walk under a raised boom/platform.
 - Be aware of the boom position and tail swing when rotating the turret (turntable).
 - Always ensure that the chassis is never kept any closer than 1 m (3 ft 3 in) to holes, bumps, slopes, obstructions, debris and ground coverings that may hide holes and other dangers.
 - Maintain a distance of at least 1 m (3 ft 3 in) or any signs on the worksite.
 - Keep non-operating personnel at least 5 m (16 ft 5 in) away from the machine when driving and slewing.
 - Become familiar with the driving direction.
 - When turret is slewed/rotated 180°, the platform is now facing the rear of the machine.
 - Check the direction of movement with the help of the red or white arrows on the chassis and on the platform control box.
 - Also note that when changing the driving direction (Forward \leftrightarrow Reverse) the joysticks or switches must return to the neutral position before reversing the drive direction and for movement to occur.
- 
- When driving, position the platform so as to provide the best possible visibility and to avoid any blind spots.
 - Hold on securely to the guardrails.
 - **Personal Protection Equipment (EPI) :**
 - The occupants of the aerial work platform must wear personal protection equipment and comply with local regulations in force.
 - Operators must comply with the safety standards of the job site and the employer, as well as the applicable state regulations relating to the use of personal protective equipment.
 - All personal fall protection equipment (PFPE) must comply with current regulations, must be inspected and used in accordance with the manufacturer's instructions.
 - Avoid contact with fixed or mobile obstacles (other machines).
 - Other machines (crane, aerial work platform, etc.) operating in the work area increase the risk of crushing or collision. Restrict the operation of machines moving within the aerial work platform work area.
 - Take into consideration the stopping distance, reduced visibility and blind spots of the machine.
 - Limit travel speed to suit the ground surface condition, slope (incline), and people in the vicinity.

3.1.7 Risk of involuntary movements

Never use a damaged or malfunctioning machine.

A - Foreword

Always respect the following rules:

- Maintain clearance from high voltage lines.
- Maintain clearance from generators, radar, electromagnetic fields.
- Never expose the batteries or electrical components to water (high pressure washer, rain).

4 Safety inquiries

Inquiries relating to design criteria/specifications of a product, standards compliance, or overall machine safety should be sent to the HAULOTTE® PRODUCT SAFETY department.

Each inquiry or request should include all relevant information; including contact name, telephone number, mailing address, email address, plus the machine model and serial number.

The HAULOTTE® Product Safety department will evaluate each request/inquiry and will provide a written response.

5 Incident notification

Notify HAULOTTE® immediately when a HAULOTTE® product has been involved in an incident/accident leading to personal injury or death, or when there is a major property damage.

HAULOTTE Group - EUROPE Product Safety Department

Address: Rue Emile Zola - 42420 Lorette - France

Tel: +33 (0)4 77 29 24 24

Email: productsafety.europe@haulotte.com

HAULOTTE Group - Australia, India and Asia Product Safety Department

Address: No.26 Changi North Way - Singapore 498812 - Singapore

Tel: +65 6546 0123

Email: productysafety.apac@haulotte.com

HAULOTTE Group - North & South America Product Safety Department

Address: 3409 Chandler Creek Rd. - Virginia Beach, VA 23453 - United States

Tel: +1 757 689 2146

Email: productsafety.americas@haulotte.com

Connect to our website: www.haulotte.com



6 Compliance

6.1 Product modification

It is strictly forbidden to modify a HAULOTTE® product. Any modification may violate Haulotte design parameters, local regulations and industry standards.

Any requests for modification must be formulated in writing (form) and be approved by the manufacturer.

Do not hesitate to contact HAULOTTE Services®, should you have any questions relating to the issued bulletin(s) or with questions on the policy itself.

6.1.1 Implementing manufacturer safety campaigns

It is essential to implement the safety campaigns issued by the manufacturer. All of these campaigns are accessible on our website.

Connect to our website: www.haulotte.com



Never market (or sell) a machine without first having carried out all of the safety campaigns.

6.2 Product specifications

HAULOTTE® cannot be held liable for any changes to the technical characteristics/specifications contained in this manual. HAULOTTE® has a continuous improvement policy in place for its product range. Given this policy, the Company reserves the right to modify products technical characteristics / specifications without notice.

6.3 Change of Ownership Notification

It is important and necessary to keep HAULOTTE Services® updated with current ownership of the machine. This way, HAULOTTE® will be able to provide the necessary support for the product. If you have sold or transferred this machine(s); it is your responsibility to notify HAULOTTE Services®. It is not required to include Lessees/Renters of Leased/Rented machines on this form.

Connect to our website: www.haulotte.com

A - Foreword



6.4 Declaration of conformity



The CE declarations of conformity only apply to machines that have been approved and commissioned within the European Community (EC).

6.4.1 Declaration of conformity - All machines



The UKCA declarations of conformity only apply to machines that have been approved and commissioned within the United Kingdom (UK).

Declaration of conformity - UKCA and CE directive



UKCA / EC DECLARATION OF CONFORMITY

HAULOTTE Factory



Declares under our own responsibility that the machine described below :

Mobile Elevating Work Platform

Commercial name
Type
Serial number

Commercial name of the concerned machine
Model type of concerned machine
Serial number of the machine

Conforms with provisions of the Regulations listed below :

CE

EC Machinery Directive 2006/42/CE
EC Directive electromagnetic compatibility 2014/30/EU
EU RED Directive on radio equipment (if machine equipped) 2014/53/UE

UKCA

Supply of Machinery (safety) 2008 SI2008/1597 amended SI2011/1043/2157 2019/696
Electromagnetic compatibility 2016 SI 2016/1091 amended SI 2017/1206, 2019/696
Radio equipment (if machinery equipped) 2017

This machine has been type examined by :

Name of the Authorized body :

Name of the Approved body :

Certificate number :

Certificate number :

Harmonized standard(s) used as reference(s) :
EN280

Designed standard(s) used as reference(s) :
BS EN280

Person authorised to compile the technical file :

HAULOTTE GROUP
Compliance Manager
RUE EMILE ZOLA
CS 30045 42420 LORETTE FRANCE

HAULOTTE UK Ltd
General Manager UK and Ireland
Unit 1 Gravelly Way, Four Ashes
Wolverhampton, West Midlands WV10 7GW
ENGLAND

Name and Signature
Division Director

Date and place

haulotte.com

777365830192340017NW2591PF-02
NW25910H-CE-UKCA-V2.0.5

6.4.2 Declaration of conformity - Electric platforms

Declaration of conformity - CE directive



DECLARATION CE DE CONFORMITE
(EC DECLARATION OF CONFORMITY)



Fabricant et personne autorisée à constituer le dossier technique : <i>(Manufacturer and the person authorised to compile the technical file.)</i>	Compliance & Regulation Director HAULOTTE GROUP S.A. RUE EMILE ZOLA
HAULOTTE GROUP	42420 LORETTE FRANCE
Adresse du site de production <i>(Address of the Division)</i>	Nacelle élévatrice de personnel <i>(Mobile Elevating Work Platform)</i>
en conformité avec le modèle type <i>(In compliance with the Model Type)</i>	Modèle type de la machine concernée <i>(Type model of the concerned machine)</i>
Nom commercial <i>(Commercial name)</i>	Nom commercial de la machine concernée <i>(Commercial name of the concerned machine)</i>
Numéro de série <i>(Serial number)</i>	Numéro de série de la machine concernée <i>(Serial number of the concerned machine)</i>
Organisme notifié <i>(Notified body)</i>	Nom et adresse de l'organisme notifié <i>(Name and address of the notified body)</i>
Numéro de certificat <i>(Certificate number)</i>	Numéro de certificat du type de machine <i>(Certificate number of the type of machine)</i>
Charge maximale d'utilisation <i>(Rated capacity)</i>	Charge maximale d'utilisation de la machine concernée <i>(Rated capacity of the concerned machine)</i>

Nous déclarons que cette machine est conforme aux dispositions des Directives suivantes
(We hereby declare that this machine conforms with all the relevant provisions of the Directives listed below)

Directive CE Machine <i>(EC Machinery Directive)</i>	2006/42/CE
Se conforme aux principales exigences de la norme harmonisée <i>(This machine also fulfils the principles of the harmonised standard)</i>	EN280
Directive CE concernant la compatibilité électromagnétique <i>(EC Directive on electromagnetic compatibility)</i>	2014/30/EU
Directive CE RED concernant les équipements radioélectriques (si machine équipée) <i>(RED EC Directive on radio electrical equipment (if machine equipped))</i>	2014/53/EU

Cetle déclaration porte exclusivement sur la machine dans l'état où elle a été placée sur le marché
(This declaration relates exclusively to the machinery in the state in which it was placed on the market)

Toute modification de la machine décrite ci-dessus a pour effet d'invalider cette déclaration
(Any modification to the above described machine violates the validity of this declaration)

Nom et signature du Directeur du site de production <i>(Name and signature of the Division Director)</i>	Lieu <i>(Place)</i>
	Date <i>(Date)</i>



B - Familiarization

1	General safety.....	3
1.1	Intended use.....	3
1.2	Decal content.....	3
1.3	Level of severity.....	4
1.4	Symbols legend and definitions.....	5
1.5	Symbols and colors.....	7
2	Models description.....	8
3	Primary machine components.....	9
3.1	Layout.....	9
3.2	Ground control box - Service / Emergency station.....	11
3.3	Platform control box - Main station.....	30
4	Performance Specifications.....	35
4.1	Technical characteristics.....	35
4.2	Working area / Range of motion.....	43
5	Decals and markings locations.....	45

B - Familiarization

1 General safety

1.1 Intended use

Do not operate the product in the following situations:

- On soft, unstable or cluttered ground.
- With wind blowing faster than the permissible limit:
 - Check the allowable wind speed specified in the performance specifications tabulation.
 - Consult the Beaufort scale.
- Close to power lines. Keep a safe distance.
- If the machine is stored at a temperature out of range - 20°C / + 50°C (- 4°F / + 122°F).
- In an explosive atmosphere / environment.
- During storms.
- In the presence of strong electromagnetic fields.

N.B.-:USE THE MACHINE UNDER "NORMAL" CLIMATIC CONDITIONS. IF YOU NEED TO USE THE MACHINE IN CLIMATIC CONDITIONS LIKELY TO CAUSE DETERIORATION (EXTREME : HUMIDITY, TEMPERATURES, SALINITY, CORROSIVENESS, ATMOSPHERIC PRESSURE), CONTACT HAULOTTE SERVICES®. REDUCE INTERVALS BETWEEN SERVICING.

N.B.-:IN HARSH ENVIRONMENTS (HIGH LEVELS OF SALINITY IN THE ATMOSPHERE: CLOSE TO THE SEA, INDUSTRIAL ENVIRONMENT WITH CHLORIDE EMISSIONS AND/OR HUMIDITY > 70%), WE RECOMMEND APPLYING SOLVENT-BASED OIL TO THE ENTIRE MACHINE.

1.2 Decal content

The purpose of the labels on the machine is to alert the user to the conditions of use and risks related to aerial work platforms.

Decals provide the following information:

- The level of severity.
- The specific hazard.
- A method to avoid, suppress or reduce the hazard.
- Descriptive text (where required).

Familiarize yourself with the decals and the hazard severity levels.

The decals must be kept in good condition. Promptly replace all decals that are no longer legible.

Familiarize yourself with the decals and their respective color codes.

Additional decals can be ordered from HAULOTTE Services®.

CE, UKCA, AS and EAC standards - Label warning risk



Marking	Description
1	Risk identification symbol
2	Avoidance symbol pictorial

B - Familiarization

CE, UKCA, AS and EAC standards - Label informing about an important function of the machine

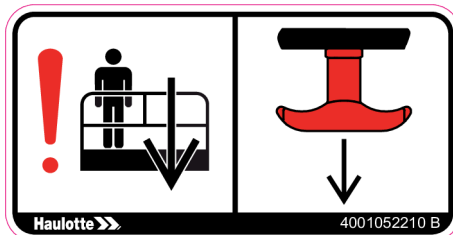

ANSI and CSA standards



Marking	Description
1	Risk identification symbol
2	Level of severity
3	Avoidance symbol pictorial
4	Avoidance text

1.3 Level of severity





















Color	Title	Description
		Danger: Indicates a hazardous situation which if not avoided, WILL result in death or serious injury.
		Warning: Indicates a hazardous situation which if not avoided, COULD result in death or serious injury.
		Caution: Failure to comply could result in minor or moderate injury.
		Notice: Indicates recommended practices if not followed, may result in a malfunction or damage the machine or its components.
		Procedure: Indicates a maintenance operation.

B - Familiarization















1.4 Symbols legend and definitions

Symbols are used throughout this manual to depict hazards, avoidance measures and indicate when information is required.

Refer to the following table to familiarize yourself with these symbols.

Symbol	Description	Symbol	Description	Symbol	Description
	Risk of crushing or pinning		Foot crushing hazard		High pressure fluid ejection hazard
			Hand crushing hazard		Crushing hazard
			Health/safety hazards related to chemicals		Burn hazard
	Risk of electrocution		Burns and scalds from contact with flames, explosion or radiation from heat sources		Injury from Electric arcs - Energy supply disconnecting devices - Batteries fire, emissions, etc
	Fall hazard		Tip over due to excessive loading / wind load and excessive ground slope		Relate and coordinate directional arrows on the chassis with those on the control box
	Do not put foot in this area		Do not put your hand in this area		Keep away from product working area
	Use of high-pressure cleaners prohibited		Ensure entry drop rail is down		

B - Familiarization







Symbol	Description	Symbol	Description	Symbol	Description
	Flames prohibited		Maintain safe clearance from high voltage electrically charged conductors as described in manual - Do not use in thunderstorms		Overload
	Refer to operator manual		Safety belt		Use appropriate lanyard attached to dedicated anchor point.
	Wheel pressure		Enable switch		Use safety prop before attempting any maintenance work
	Tow point		Tie down point		Lift point
	Keep away from hot surfaces		Wear protective equipment		

B - Familiarization

1.5 Symbols and colors

Symbols and colors are used to alert the operator of safety precautions and/or to highlight important safety information.

The following safety symbols are used throughout this manual to indicate specific hazards and the hazard severity level when operating or maintaining the Aerial Work Platform.

Symbol	Description
	Danger: Risk of injury or death
	Caution: Risk of material damage
	Prohibited action
	Reminder to use good practice or follow pre-operation checks
	Cross-reference to another part of the manual
	Cross-reference to another manual
	Cross-reference to repair (contact HAULOTTE Services®)
N.B.:	Additional technical information

B - Familiarization**2 Models description**

Models	Regulations						
	CE	UKCA	ANSI	CSA	EAC	AS	JIS
SIGMA 16	✓	✓	✗	✗	✓	✓	✓
SIGMA 16 PRO	✓	✓	✗	✗	✓	✓	✓
SIGMA 46	✗	✗	✓	✓	✗	✗	✗
SIGMA 46 PRO	✗	✗	✓	✓	✗	✗	✗
Legend							
✓	Available						
✗	Not available						

B - Familiarization

3 Primary machine components

3.1 Layout

SIGMA 16 - SIGMA 46 - SIGMA 16 PRO - SIGMA 46 PRO

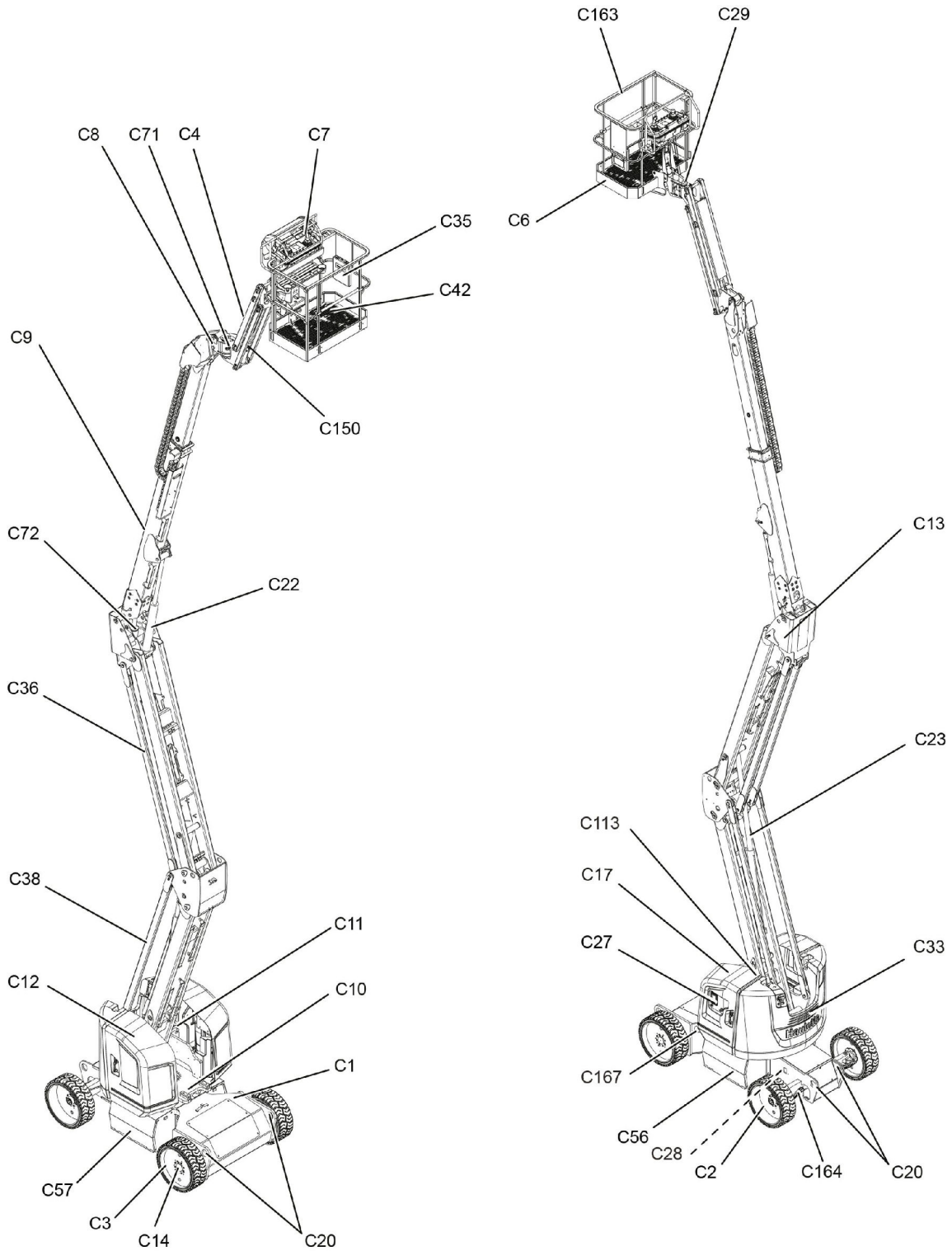

B - Familiarization

Marking	Description	Marking	Description
C1	Chassis	C27	Ground control box+Universal plug
C2	Steering wheel	C28	Tilt sensor
C3	Drive wheel	C29	Platform rotation cylinder
C4	Jib	C33	Counterweight
C6	Platform	C35	Document holder
C7	Platform control box	C36	Top arm
C8	Input jib leveling cylinder	C38	Bottom arm
C9	Upper boom	C42	Foot Switch
C10	Slew ring	C56	Battery box-Right (4 6 V batteries)
C11	Turntable assembly	C57	Battery box-Left (4 6 V batteries)
C12	Hydraulic block - Emergency manual lowering	C71	Jib rotation cylinder (If equipped)
C13	Arm/Boom link piece	C72	Output jib compensation cylinder
C14	Electric drive motor and reducer	C113	Beacon light (Optional)
C17	Right side compartment	C150	Jib lifting cylinder
C20	Tie-down (and/or lifting) points	C163	Hand (grab) rail
C22	Boom lift cylinder	C164	Front steering axle
C23	Arm lifting cylinder	C167	Battery charger socket

Universal plug



B - Familiarization

3.2 Ground control box - Service / Emergency station













3.2.1 Layout-Touch screen display

General view









B - Familiarization





Controls and indicators

Marking	Name	Description	Function
1	SA720U	Platform tilt control	By pressing on  : Tilt the platform towards the front of the machine.
	SA720D		By pressing on  : Tilt the platform towards the back of the machine.
2	SA620U	Jib raising / lowering control	By pressing on  : Jib raising.
	SA620D		By pressing on  : Jib lowering.
3	SA530O	Boom telescoping switch	By pressing on  : Boom extending.
	SA530I		By pressing on  : Boom retracting.
4	SA520U	Boom raising / lowering control	By pressing on  : Boom raising.
	SA520D		By pressing on  : Boom lowering.
5	SA420U	Arm raising / lowering control	By pressing on  : Arm raising.
	SA420D		By pressing on  : Arm lowering.
6	SA905EN	Enable Switch	By pressing on Enable Switch  and simultaneously a desired function will activate a movement.
7	SA250L	Turntable rotation switch	By pressing on  : Counter clockwise (CCW) rotation.
	SA250R		By pressing on  : Clockwise (CW) rotation.

B - Familiarization

Marking	Name	Description	Function
8	SA750L	Platform rotation switch	By pressing on  : Clockwise (CW) rotation.
	SA750R		By pressing on  : Counter clockwise (CCW) rotation.
9	SB801	Emergency Stop button	Pulled out: Ground control box energized.
			Pushed in (activated): De-energizes control system.
10	HL905	Indicator, ground control box selected	LED lights up - ground control box icon.
11	SA801	Overriding system control	By pressing on  : Authorize movements from the ground control box in case of overload - Use ONLY in case of emergency.
12	SB907	Horn button	By pressing on  : Horn activation.
13	HL906	Indicator of the platform control box selection	LED lights up - platform control box icon.
14	SA903	Beacon light on/off (Optional)	By pressing on  : Beacon light ON / OFF.
15	HL909	Overload indicator - Alarm	Alarm icon 
			<ul style="list-style-type: none"> - The icon lights up for 1 s when switched on. - The icon flashes slowly if the machine is not configured (country, model or component not set). - The icon flashes quickly if the "Overriding system" is in use. - The icon lights up steadily in case of overload or weighing system fault. The machine overload status is displayed on the onboard screen.
16	HL908	Fault indicator	Warning icon 
			<ul style="list-style-type: none"> - The icon lights up for 1 s when switched on. - The icon flashes slowly if the machine is not configured (country, model or component not set). - The icon flashes quickly if the "Overriding system" is in use. - The icon lights up steadily if a fault is detected. An error code is displayed on the onboard screen.

B - Familiarization

Marking	Name	Description	Function
21	SA901	Control box activation key switch	 : De-energizes control system.
			 : Platform control box energized.
			 : Ground control box energized.
22		Touch screen display	
23	SA650L	Jib rotation selector	By pressing on  : Clockwise (CW) rotation.
	SA650R		By pressing on  : Counter clockwise (CCW) rotation.

3.2.2 Touch screen display

Upon starting and during operation of the machine, the touch screen display located on the ground control box displays in real time the machine operating status.

B - Familiarization

Touch screen display

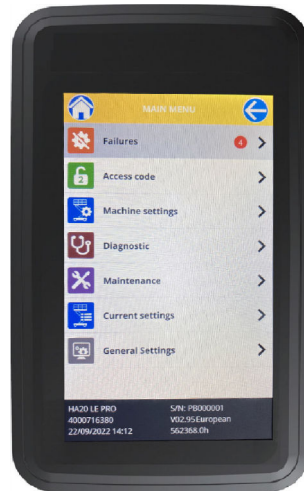

	Home Button
	Back button
	Access menu button
	Failures
	Access code
	Machine settings
	Diagnostic
	Maintenance
	Current settings
	General settings

N.B.-:PRESS YOUR FINGER ON THE TOUCH SCREEN TO NAVIGATE THROUGH THE DIFFERENT MENUS. FOR EXAMPLE, PRESS CURRENT SETTINGS, THE FOLLOWING WINDOW WILL OPEN

B - Familiarization

Navigation in the menus

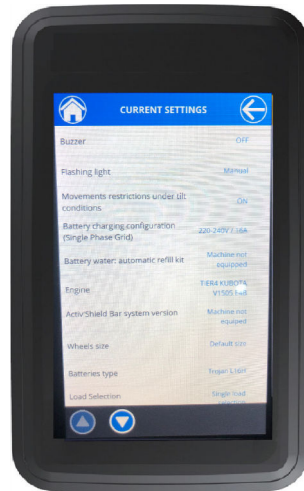







Scroll down screen button (Scrolling is possible by sliding your finger vertically on the screen)

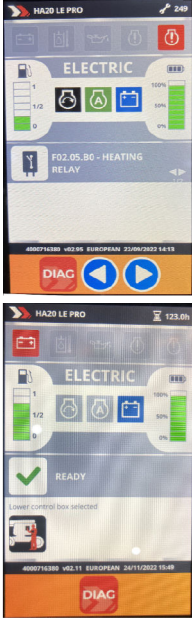

Scroll up button (Scrolling is possible by sliding your finger vertically on the screen)

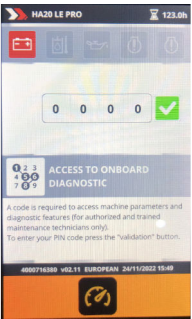

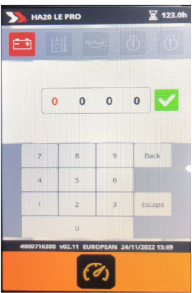
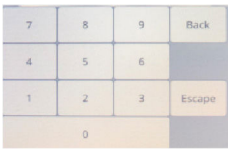

B - Familiarization

Controls and indicators



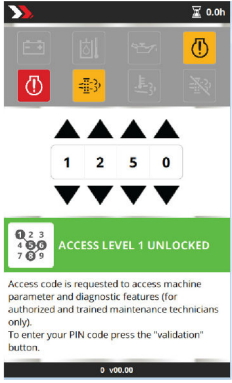

Icon	Description	Icon	Description
			<p>Press this icon to enter the diagnostic access code</p>
	<p>Access code (Will be visible - depending on the machine)</p>		<p>Access code not yet entered</p>
			<p>Access code entered is correct (Level 1, 2 or 3 depending on authorization of technician)</p>
			<p>Access code entered is incorrect</p>
	<p>Enter access code (Will be visible - depending on the machine)</p>		<p>Enter the access code using the keypad (Press the touch screen)</p>
			<p>Validation of the access code (Press the touch screen)</p>

B - Familiarization



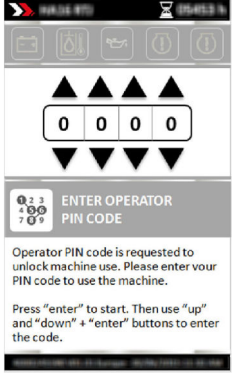

Controls and indicators

Icon	Description	Icon	Description
	Access code NIV 1 (Will be visible - depending on the machine)	The machine can be personalized with a user identification code. Personalization is only possible with NIV 1 : 1250 access. Machine properties display: Soft version, machine serial number, adjustment parameters. Possible change of parameters: Language, fault display format, brightness setting, time, and some options available.	
			Operator PIN code not yet entered
			Operator PIN code entered is correct
			Operator PIN code entered is incorrect

Controls and indicators

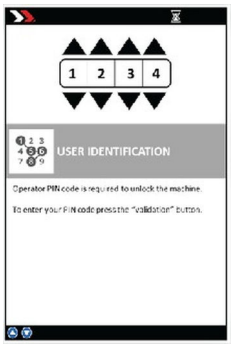



Icon	Description	Icon	Function
	Operator PIN code (Will be visible - depending on the machine)	The machine can be personalized with a user identification code. Personalization is only possible with NIV 2 access. Contact HAULOTTE Services®.	
			Operator PIN code not yet entered
			Operator PIN code entered is correct
			Operator PIN code entered is incorrect

Controls and indicators







Icon	Description	Icon	Description	Function
	Access code (Will be visible - depending on the machine)		Access code not yet entered	
			Access code entered is correct (Level 1, 2 or 3 depending on authorization of technician)	
			Access code entered is incorrect	

B - Familiarization

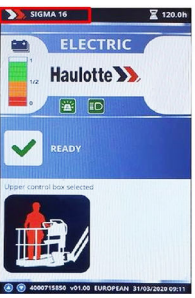
Controls and indicators

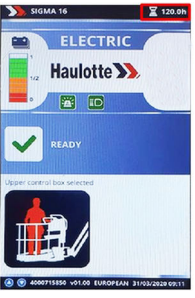

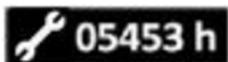
Icon	Description	Icon	Description	Function
	Operator PIN code (Will be visible - depending on the machine)	The machine can be personalized with a user identification code. Personalization is only possible with NIV 2 access. Contact HAULOTTE Services®.		
		Operator PIN code not yet entered		
		Operator PIN code entered is correct		
		Operator PIN code entered is incorrect		

Controls and indicators

Icon	Function	Icon	Description	Function
Home screen (dashboard) - Will be visible - depending on the machine				
	Machine model zone		Machine model	Machine model display
		Hour meter/next maintenance zone		Hourmeter
			Maintenance use	The Maintenance Tool icon and the number of hours remaining until the next maintenance are displayed for 5 seconds when the machine is started up.
				The maintenance tool icon turns RED when the next scheduled maintenance must be carried out in under 25 hours.

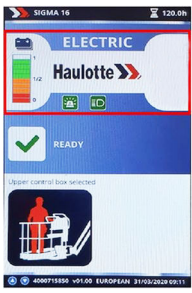
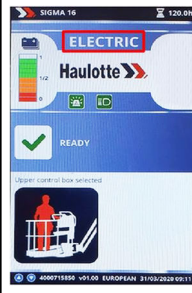
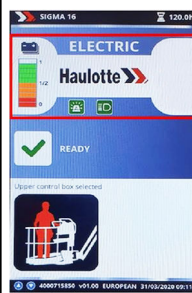
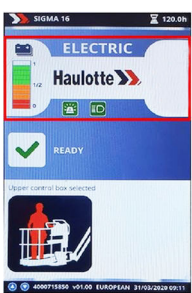
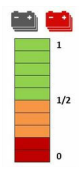
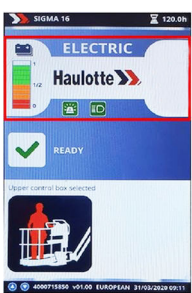
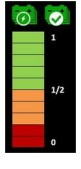

B - Familiarization

Controls and indicators



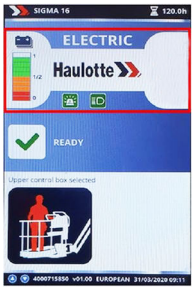
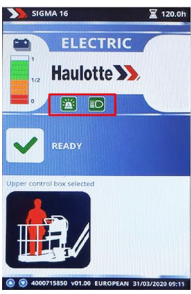

Icon	Function	Icon	Description	Function
Home screen (dashboard) - Will be visible - depending on the machine				
	Functional information zone		Power mode used	- Electrical
		Bargraph		
	Functional information zone		Analog Gauge-Battery charging indicator	The battery discharge indicator turns from GREEN to RED when the battery status is less than 20%
			Analog Gauge-Battery charging indicator (Machine is charging)	 : Charging  : Battery charged

B - Familiarization

Controls and indicators

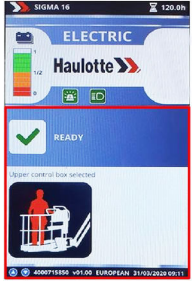



Icon	Function	Icon	Description	Function
Home screen (dashboard) - Will be visible - depending on the machine				
	Functional information zone		Additional functions	
			Beacon	The icon is ON when the flashing light is switched on
			Activ' Lighting System	The icon is ON when the Activ' Lighting System is switched on in auto or manual mode

Controls and indicators

Icon	Function	Icon	Description	Function
Home screen (dashboard) - Will be visible - depending on the machine				
	Machine status zone		Pictogram and title	Displays the pictogram and machine status
			Ready	Machine ready, displayed when no failures and no other machine state icons is active
			Alarm	The alarm icon blinks in case of <ul style="list-style-type: none"> - Machine failure - Failure detected - Machine overloaded - Machine on excessive slope Another icon will be displayed to show the machine's status, the failure or the malfunction

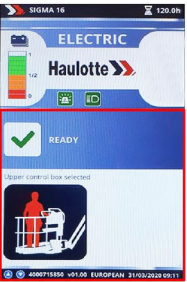
B - Familiarization

Controls and indicators



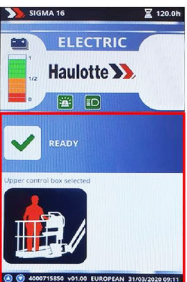
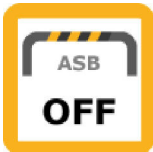

Icon	Function	Icon	Description	Function
Home screen (dashboard) - Will be visible - depending on the machine				
	Machine status zone		Platform control selected	Selector switch is in platform control box position
			Ground control selected	Selector switch is in ground control box position
			Tilt	The machine is elevated , and is on a slope greater than the permitted slope. Depending on the machine configuration, machine raise and extend functions may be slowed or prevented.
			Overload	The platform is overloaded. Remove the excessive load to or below the rated capacity, to restore functions. In case of an emergency, to rescue the operator in platform, use the Overriding system.

Controls and indicators



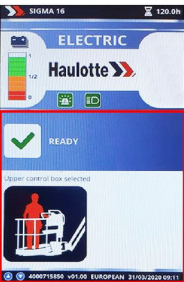

Icon	Function	Icon	Description	Function
Home screen (dashboard) - Will be visible - depending on the machine				
	Machine status zone		Activ' Shield Bar disable	The secondary safety system is switched off

B - Familiarization

Controls and indicators

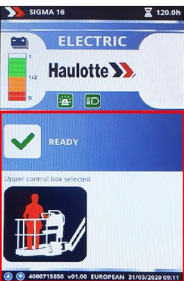

Icon	Function	Icon	Description	Function
Home screen (dashboard) - Will be visible - depending on the machine				
	Machine status zone		Activ' Shield Bar triggered	<div style="display: flex; align-items: center;">  <div style="margin-left: 10px;"> <p>The secondary safety system is triggered. An operator may be trapped on the platform</p> <ul style="list-style-type: none"> - In this situation, supervisor(s) at ground level must turn the control box key selector (21) to the ground position to take control. - The platform box controls are now de-energized. - Check that the Emergency Stop button (9) at ground is not pressed in. - To safely activate movements from the ground control box, the Enable Switch (6)  must be pressed and held. </div> </div>

Controls and indicators



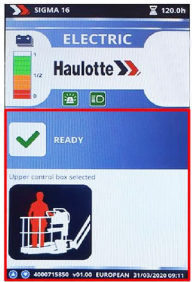
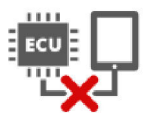

Icon	Function	Icon	Description	Function
Home screen (dashboard) - Will be visible - depending on the machine				
	Machine status zone		Movement restricted due to critical battery level	The battery level is critical. Battery recharge is mandatory.
			Battery level low	Recharge batteries.
			Battery charge complete	

B - Familiarization

Controls and indicators

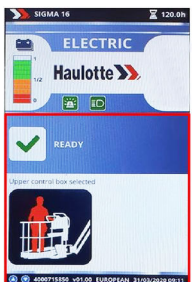

Icon	Function	Icon	Description	Function
Home screen (dashboard) - Will be visible - depending on the machine				
	Machine status zone		F12.01 bus CAN fault	CAN network fault between the screen and the rest of the machine
			Screen software obsolete	Screen software update essential Contact HAULOTTE Services®
			Diagnostic in progress	The HaulotteDiag console is connected to the machine

Controls and indicators

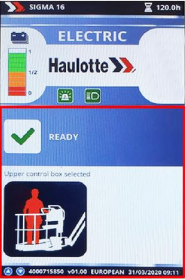

Icon	Function	Icon	Description	Function
Home screen (dashboard) - Will be visible - depending on the machine				
	Machine status zone		Platform control box Emergency Stop button	Emergency Stop at platform control box has been pushed in (de-energized). The machine will switch off after several seconds. In an emergency, use this mode.
			Emergency mode valid	Emergency Mode, use only to rescue trapped or incapacitated operator. Press and hold this Emergency Button AND the movement button required.
			Emergency mode not active	This is for emergency use. Only active when the load detection system is on.

B - Familiarization

Controls and indicators

Icon	Function	Icon	Description	Function
Home screen (dashboard) - Will be visible - depending on the machine				
	Machine status zone		Auto beacon	Flashing light control is in automatic mode.
			Activ' Lighting System	The function is off. To switch it on, go to the 'Settings' menu

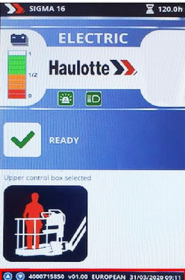
Controls and indicators

Icon	Function	Icon	Description	Function
Home screen (dashboard) - Will be visible - depending on the machine				
	General information zone		Machine software version and code	Displays the reference and version of the software installed on the machine
			Machine date and time	Displays the date and time of the machine ECU

B - Familiarization

Controls and indicators





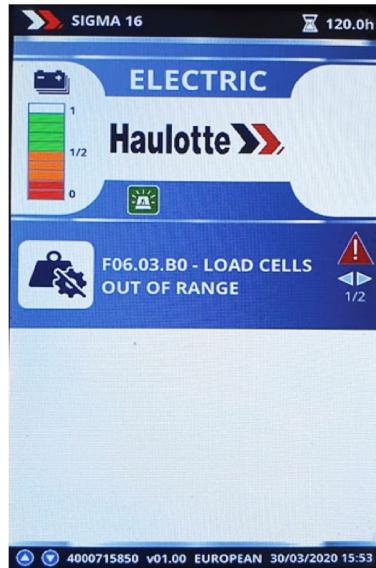

Icon	Description	Function	Icon	Description	Function
------	-------------	----------	------	-------------	----------

Machine fault

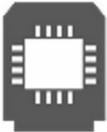
(Will be visible - depending on the machine)



Machine fault icons

	Failure code F01.xx	Fault-Inverter		Failure code F10.xx	Fault - Functions
	Failure code F02.xx	Fault - power contactor		Failure code F11.xx	Fault - machine safety
	Failure code F03.xx	Fault - command relay		Failure code F12.xx	Fault - electronic control unit ECU - CAN
	Failure code F04.xx	Fault - electro-valve			

B - Familiarization

Controls and indicators







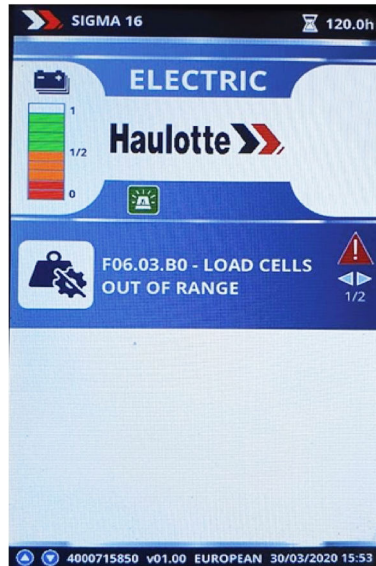

Icon	Description	Function	Icon	Description	Function
------	-------------	----------	------	-------------	----------

Machine fault

(Will be visible - depending on the machine)



Machine fault icons



	Failure code F05.xx	Fault - joystick		Failure code F13.xx	Fault - Switches
	Failure code F06.xx	Fault - weight management system		Failure code F15.xx	Fault - data communication system CAN
	Failure code F07.xx	Fault - limit switch or sensor		Failure code F16.xx	Fault - Drive motors
	Failure code F08.xx	Fault - electrical circuit		Failure code F17.xx	Fault - Pump motor

B - Familiarization

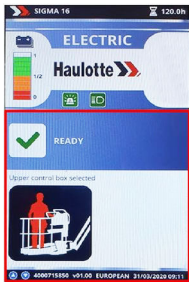
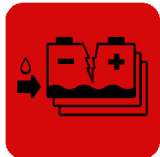
Controls and indicators

Icon	Function	Icon	Description	Function
Filling if battery level alarm (Without automatic centralised filling option)				
If "low water level" battery sensor is active 			Low battery water level	<p>Low battery water level</p> <ul style="list-style-type: none"> - You must first fully recharge the batteries and then refill the batteries with demineralized water - When the water level is low, high risk of batteries damage

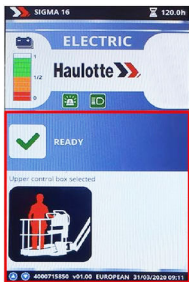
Controls and indicators

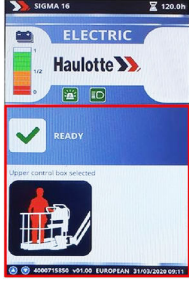
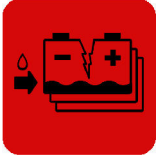



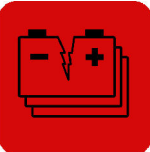

Icon	Function	Icon	Description	Function
Filling if battery level alarm (With automatic centralized filling option)				
If low water level tank sensor is active 			Low Water level tank - Refill the water battery tank with demineralized water.	
If "low water level" battery sensor is active 			Low battery water level	<p>Low battery water level</p> <ul style="list-style-type: none"> - You must first refill the tank with demineralized water and then make a full recharge. - If the level of water is not correct, risk of damage the battery.

B - Familiarization

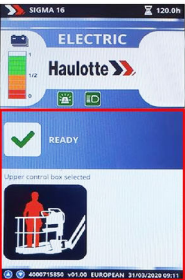
Controls and indicators

Icon	Function	Icon	Description	Function
A full charge every 45 hours				
	35 hours without full recharge	Battery recharge	Warning next recharge must be a full recharge by plugging the machine electrical socket to external source of power to prevent damage on the batteries	
	45 hours without full recharge		You must full recharge by plugging the machine electrical socket to external source of power Risk of damage on the batteries.	

Controls and indicators



Icon	Function	Icon	Description	Function
Home screen (dashboard) - Will be visible - depending on the machine				
	Machine status zone		Schedule maintenance	 Refer to the Service Manual
			Too hot to charge	The battery temperature is too high. Charging them now would cause damage.
			Too cold to charge	The battery temperature is too low. Charging them now would cause damage.
			High temperature	In order to protect your machine, it is currently on a derating mode.

B - Familiarization

3.3 Platform control box - Main station

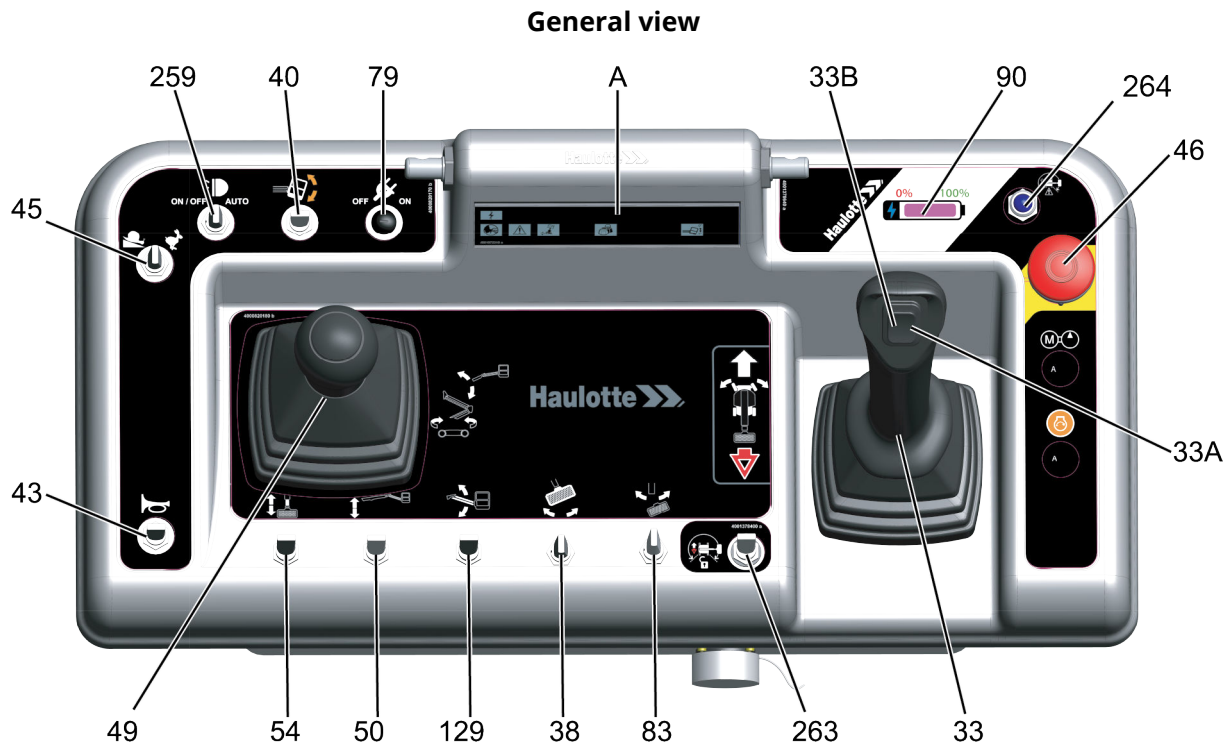
3.3.1 Layout



**Controls and indicators**

Marking	Name	Description	Function
33	SM902	Drive joystick	Move forward: Forward drive
			Move backwards: Reverse drive
33A		Steering button (Steering thumb / rocker switch)	Press right side of button: Steer right
33B	Press left side of button: Steer left		
38	SA751	Platform rotation switch	Move to the right: Counter clockwise (CCW) rotation
			Move to the left: Clockwise (CW) rotation
40	SA721	Platform leveling switch	Move forward: Platform tilt up
			Move backwards: Platform tilt down
43	SA907	Horn button	Horn
45	SA110	Drive speed selector	 High-speed drive
			 Low-speed drive - Ramps

B - Familiarization

Marking	Name	Description	Function
46	SB802	Emergency Stop button	Pulled out: Platform control box energized
			Pressed in: De-energizes control system
49	SM900	Turntable rotation joystick	Move to the right: Counter clockwise (CCW) rotation
			Move to the left: Clockwise (CW) rotation
		Boom raise / lower joystick	Move forward: Raise boom
			Move backwards: Lower boom
50	SA421	Arm lifting selector	Move forward: Arm raises
			Move backwards: Arm lowers
54	SA531	Boom telescoping switch	Move forward: Boom retracts
			Move backwards: Boom extends
79	SA906	Power converter control	Move to the left: Control deactivated
			Move to the right: Control activated
83	SA651	Jib rotation selector	Move to the right: Counter clockwise (CCW) rotation
			Move to the left: Clockwise (CW) rotation
90	LBB02	Battery charging indicator	<p>Battery charge status.</p> <p>After 45 hours of use without recharging, the last digit of the bargraph will flash red whatever the charge status of the battery</p> <p>On the screen (22) of the ground control box, the current charge status of the battery will be displayed as well as the message that recharging is complete after 45 hours</p>
129	SA621	Jib raising / lowering control	Move forward: Jib raising
			Move backwards: Jib lowering

B - Familiarization





Marking	Name	Description	Function
259	SA910	Activ' Lighting System selector	Move to the left:  ON / OFF
			Move to the right:  Automatic lighting
263	SA260	Drive Orientation Assist selector ⁽¹⁾	Activated: Authorize drive movement in restricted area
264	HL260	Drive Orientation Assist Indicator ⁽¹⁾	Constantly on: <ul style="list-style-type: none"> - The machine is in restricted area - Movement is not authorized
			Rapid flashing: <ul style="list-style-type: none"> - When the (263) selector is activated - When the machine is in restricted area and a drive movement is in progress
A	LBB01	Upper control box display (LED 101 - 116)	

⁽¹⁾ For Australia only

B - Familiarization

3.3.2 Battery charging indicator(90)

Battery charge status

Icon	Function
	From 100% to 50%, the LED is green with the battery charge level displayed
	From 50% to 20%, the LED is orange with the battery charge level displayed
	- From 10% to 20%, the second LED is red with the battery charge level displayed
	- From 0% to 10%, the first 2 LEDs are alternately red with the battery charge level displayed



After 45 hours of machine movement without fully recharging the batteries and whatever the battery charge status, the first 2 LEDs are alternately red with the battery charge level displayed.







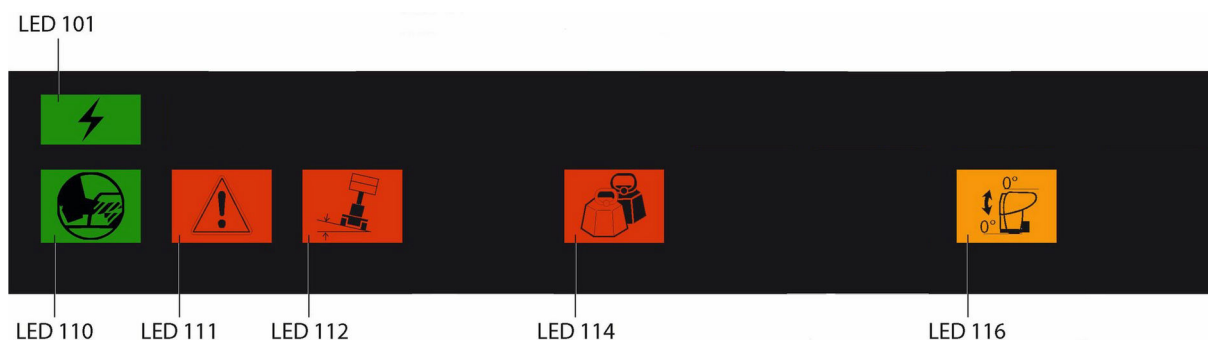

On the screen (22) of the ground control box, the current charge status of the battery will be displayed as well as the message that recharging is complete after 45 hours.

3.3.3 Display Panel (LED'S 101 - 116)

Upper control box display



B - Familiarization

Marking	Name	Symbol	Function
LED 101	HL900		Machine switched on: <ul style="list-style-type: none"> - Rapid flashing: Machine is ON, but platform control box is not active but the ground control box is ON - Illuminated: Machine is turned on and platform control panel is active
LED 110	HL807		Foot Switch: <ul style="list-style-type: none"> - Illuminated when Foot Switch activated
LED 111	HL801		Faults: <ul style="list-style-type: none"> - Rapid flashing: If a fault is active (current fault)
LED 112	HL800		Tilt sensor: <ul style="list-style-type: none"> - Illuminated when in tilt, machine stowed or unfolded
LED 114	HL802		Overload: <ul style="list-style-type: none"> - Rapid flashing: Faulty weighing / overload system - Illuminated when overloaded
LED 116	HL720		Platform leveling +/- 10°: <ul style="list-style-type: none"> - Illuminated if the angle of the platform reaches +/- 10° in relation to the horizontal and movement control

B - Familiarization

4 Performance Specifications

4.1 Technical characteristics

Use the table to select the right Haulotte machine for the job.



Do not replace parts that are essential to the stability of the machine, such as batteries or tyres, with parts that have a different weight or different specifications. The stability of the machine could be affected.

CE, UKCA, AS, EAC, CSA and ANSI A92.20 standards

Machine	SIGMA 16	
	SI	Imp.
Maximum working height	16,10 m	52 ft 10 in
Maximum platform height	14,10 m	46 ft 3 in
Maximum horizontal reach	8,35 m	27 ft 5 in
Maximum outreach above the ground	7,85 m	25 ft 9 in
Maximum boom articulation point height	7,40 m	24 ft 3 in
Maximum load capacity	230 kg	500 lbs
Jib working range	- 65° / + 65°	
Basket rotation angle	- 82,5° / + 82,5°	
Boom rotation angle	75°	
Turntable rotation	355°	
Maximum number of occupants	2	
Maximum wind speed	45 km/h (12,5 m/s)	28 mph (41 ft/s)
Gradeability	25 %	
Sideslope	25 %	
Maximum rated slope allowed	4°	
Manual lateral force at platform	400 N - 90 lbf	
Maximum load on wheel	3 670 kg	8,092 lbs
Outside turning radius	3,90 m	12 ft 10 in
Inside turning radius	2,52 m	8 ft 3 in
Maximum ground pressure of wheel on paved ground ⁽¹⁾	13,7 daN/cm ²	28 613 lb/ft ²
Total weight	6 900 kg	15,215 lbs

⁽¹⁾ The pressure values are given for standard machines without Option

B - Familiarization

Machine	SIGMA 16	
	SI	Imp.
Drive speed	0,4 km/h	0.25 mph
- Micro speed (Machine elevated)	2 km/h	1.2 mph
- Slow speed (Machine elevated)	5 km/h	3.10 mph
- High speed (Machine folded/stowed)		
Maximum freewheel speed during towed operation	5 km/h	3.10 mph

Specifications - Performance

Operating temperature	From - 20°C to + 50°C (From - 68°F to + 122°F)
Operating temperature For EAC only - If machine equipped with the option	From - 30°C to + 50°C (From - 22°F to + 122°F)
Storage temperature	From - 40°C to + 70°C (From - 104°F to + 158°F)

Power source - Electric

Type of battery		Battery weight	System voltage	Capacity
Semi-traction battery	Standard	57 kg (125 lb) per block	48V (6V x 8 blocks)	357 Ah (C5)
Battery AGM	Option	54,2 kg (120 lb) per block	48V (6V x 8 blocks)	331 Ah (C5)
Battery AGM	Option	49 kg +/- 5kg (108 lb +/- 11 lb) per block	48V (6V x 8 blocks)	331 Ah (C5)
Traction battery	Option	22,5 kg (50 lb) per item	48V (6V x 24 items)	360 Ah (C5)
Hydraulic tank capacity			21 L	6 gal US

B - Familiarization**CE, UKCA, AS, EAC, CSA and ANSI A92.20 standards**

Machine	SIGMA 46	
	SI	Imp.
Maximum working height	16,10 m	52 ft 10 in
Maximum platform height	14,10 m	46 ft 3 in
Maximum horizontal reach	8,35 m	27 ft 5 in
Maximum outreach above the ground	7,85 m	25 ft 9 in
Maximum boom articulation point height	7,40 m	24 ft 3 in
Maximum load capacity	230 kg	500 lbs
Jib working range	- 65° / + 65°	
Basket rotation angle	- 82,5° / + 82,5°	
Boom rotation angle	75°	
Turntable rotation	355°	
Maximum number of occupants	2	
Maximum wind speed	45 km/h (12,5 m/s)	28 mph (41 ft/s)
Gradeability	25 %	
Sideslope	25 %	
Maximum rated slope allowed	4°	
Manual lateral force at platform	400 N - 90 lbf	
Maximum load on wheel	3 670kg	8,092 lbs
Outside turning radius	3,90 m	12 ft 10 in
Inside turning radius	2,52 m	8 ft 3 in
Maximum ground pressure of wheel on paved ground ⁽¹⁾	13,7 daN/cm ²	28 613 lb/ft ²
Total weight	6 900 kg	15,215 lbs
Drive speed	0,4 km/h	0.25 mph
- Micro speed (Machine elevated)	2 km/h	1.2 mph
- Slow speed (Machine elevated)	5 km/h	3.10 mph
- High speed (Machine folded/stowed)		
Maximum freewheel speed during towed operation	5 km/h	3.10 mph
Specifications - Performance		
Operating temperature	From - 20°C to + 50°C (From - 68°F to + 122°F)	

B - Familiarization

Machine	SIGMA 46	
	SI	Imp.
Operating temperature For EAC only - If machine equipped with the option	From - 30°C to + 50°C (From - 22°F to + 122°F)	
Storage temperature	From - 40°C to + 70°C (From - 104°F to + 158°F)	

Power source - Electric

Type of battery		Battery weight	System voltage	Capacity
Semi-traction battery	Standard	57 kg (125 lb) per block	48V (6V x 8 blocks)	357 Ah (C5)
Battery AGM	Option	54,2 kg (120 lb) per block	48V (6V x 8 blocks)	331 Ah (C5)
Battery AGM	Option	49 kg +/- 5 kg (108 lb +/- 11 lb) per block	48V (6V x 8 blocks)	331 Ah (C5)
Traction battery	Option	22,5 kg (50 lb) per item	48V (6V x 24 items)	360 Ah (C5)
Hydraulic tank capacity			21 L	6 gal US

B - Familiarization

Machine	SIGMA 16 PRO	
Characteristics - Dimensions	SI	Imp.
Maximum working height	15,70 m	41 ft 6 in
Maximum platform height	13,70 m	44 ft 11 in
Maximum horizontal reach	8,05 m	27 ft 5 in
Maximum outreach above the ground	7,55 m	24 ft 9 in
Maximum boom articulation point height	7,40 m	24 ft 3 in
Maximum load capacity	230 kg	500 lbs
Jib working range	- 65°/ + 65°	
Horizontal jib rotation	- 55°/ + 55°	
Basket rotation angle	- 82,5°/ + 82,5°	
Boom rotation angle	75°	
Turntable rotation	355°	
Maximum number of occupants	2	
Maximum wind speed	45 km/h (12,5 m/s)	28 mph (41 ft/s)
Gradeability	25 %	
Sideslope	25 %	
Maximum rated slope allowed	4°	
Manual force	400 N - 90 lbf	
Maximum load on wheel	3 670 kg	8,092 lbs
Outside turning radius	3,90 m	12 ft 10 in
Inside turning radius	2,52 m	8 ft 3 in
Maximum ground pressure of wheel on paved ground ⁽¹⁾	13,7 daN/cm ²	28 613 lb/ft ²
Total weight	6 950 kg	15,325 lbs
Drive speed	0,4 km/h	0.25 mph
- Micro speed (Machine elevated)	2 km/h	1.2 mph
- Slow speed (Machine elevated)	5 km/h	3.10 mph
- High speed (Machine folded/stowed)		
Maximum freewheel speed during towed operation	5 km/h	3.10 mph
Specifications-Performance		
Operating temperature	From - 20°C to + 50°C (From - 68°F to + 122°F)	

B - Familiarization

Machine	SIGMA 16 PRO
Operating temperature For EAC only - If machine equipped with the option	From - 30°C to + 50°C (From - 22°F to + 122°F)
Storage temperature	From - 40°C to + 70°C (From - 104°F to + 158°F)

Power source - Electric

Type of battery		Battery weight	System voltage	Capacity
Semi-traction battery	Standard	57 kg (125 lb) per block	48V (6V x 8 blocks)	357 Ah (C5)
Battery AGM	Option	54,2 kg (120 lb) per block	48V (6V x 8 blocks)	331 Ah (C5)
Battery AGM	Option	49 kg +/- 5 kg (108 lb +/- 11 lb) per block	48V (6V x 8 blocks)	331 Ah (C5)
Traction battery	Option	22,5 kg (50 lb) per item	48V (6V x 24 items)	360 Ah (C5)
Hydraulic tank capacity			21 L	6 gal US

B - Familiarization

Machine	SIGMA 46 PRO	
Characteristics - Dimensions	SI	Imp.
Maximum working height	15,70 m	41 ft 6 in
Maximum platform height	13,70 m	44 ft 11 in
Maximum horizontal reach	8,05 m	27 ft 5 in
Maximum outreach above the ground	7,55 m	24 ft 9 in
Maximum boom articulation point height	7,40 m	24 ft 3 in
Maximum load capacity	230 kg	500 lbs
Jib working range	- 65° / + 65°	
Horizontal jib rotation	- 55° / + 55°	
Basket rotation angle	- 82,5° / + 82,5°	
Boom rotation angle	75°	
Turntable rotation	355°	
Maximum number of occupants	2	
Maximum wind speed	45 km/h (12,5 m/s)	28 mph (41 ft/s)
Gradeability	25 %	
Sideslope	25 %	
Maximum rated slope allowed	4°	
Manual force	400 N - 90 lbf	
Maximum load on wheel	3 670kg	8,092 lbs
Outside turning radius	3,90 m	12 ft 10 in
Inside turning radius	2,52 m	8 ft 3 in
Maximum ground pressure of wheel on paved ground ⁽¹⁾	13,7 daN/cm ²	28 613 lb/ft ²
Total weight	6 950 kg	15,325 lbs
Drive speed	0,4 km/h	0.25 mph
- Micro speed (Machine elevated)	2 km/h	1.2 mph
- Slow speed (Machine elevated)	5 km/h	3.10 mph
- High speed (Machine folded/stowed)		
Maximum freewheel speed during towed operation	5 km/h	3.10 mph
Specifications-Performance		
Operating temperature	From - 20°C to + 50°C (From - 68°F to + 122°F)	

B - Familiarization

Machine	SIGMA 46 PRO
Operating temperature For EAC only - If machine equipped with the option	From - 30°C to + 50°C (From - 22°F to + 122°F)
Storage temperature	From - 40°C to + 70°C (From - 104°F to + 158°F)

Power source - Electric

Type of battery		Battery weight	System voltage	Capacity
Semi-traction battery	Standard	57 kg (125 lb) per block	48V (6V x 8 blocks)	357 Ah (C5)
Battery AGM	Option	54,2 kg (120 lb) per block	48V (6V x 8 blocks)	331 Ah (C5)
Battery AGM	Option	49 kg +/- 5 kg (108 lb +/- 5 kg) per block	48V (6V x 8 blocks)	331 Ah (C5)
Traction battery	Option	22,5 kg (50 lb) per item	48V (6V x 24 items)	360 Ah (C5)
Hydraulic tank capacity			21 L	6 gal US

B - Familiarization

4.2 Working area / Range of motion

SIGMA 16 - SIGMA 46

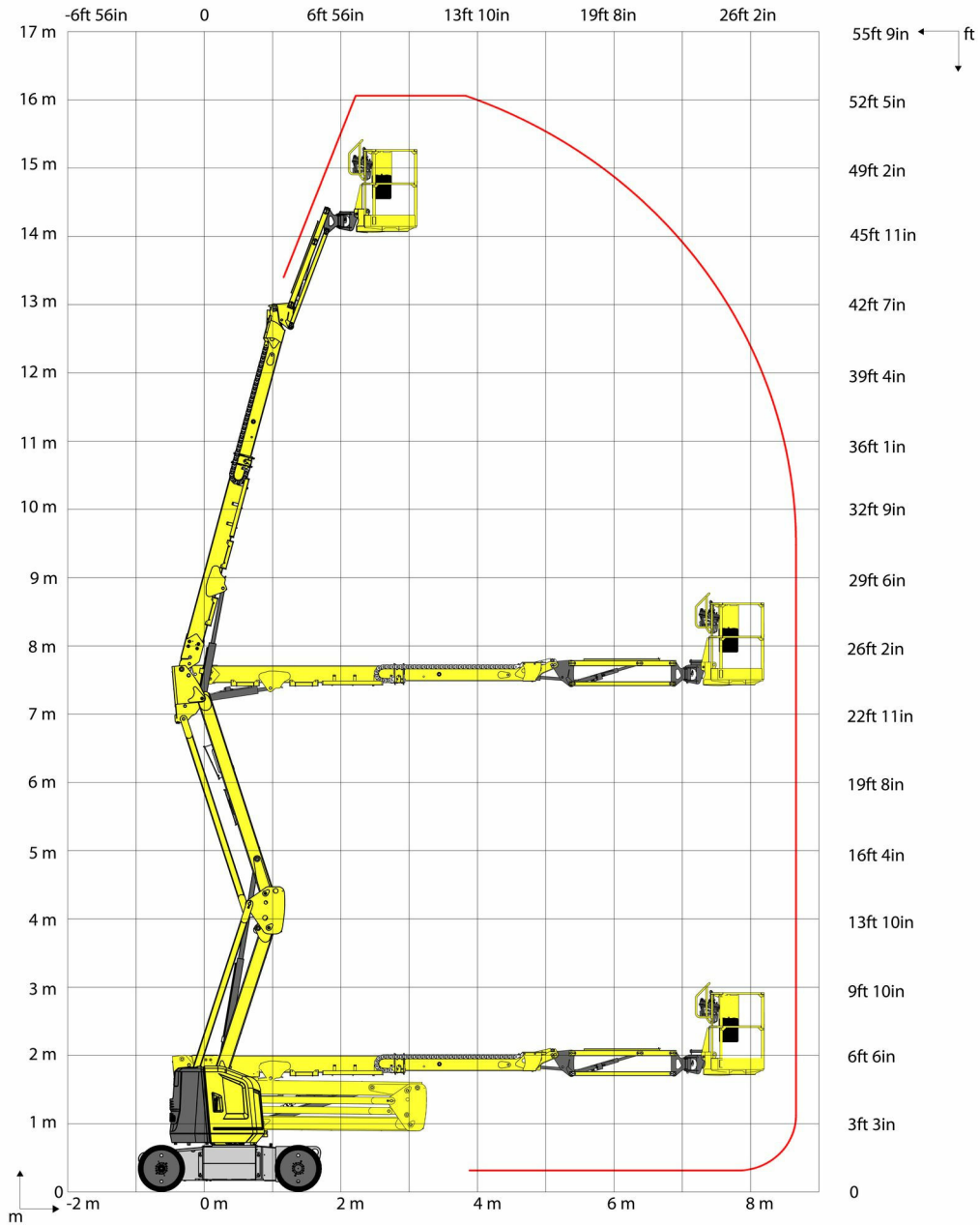

B - Familiarization

SIGMA 16 PRO - SIGMA 46 PRO

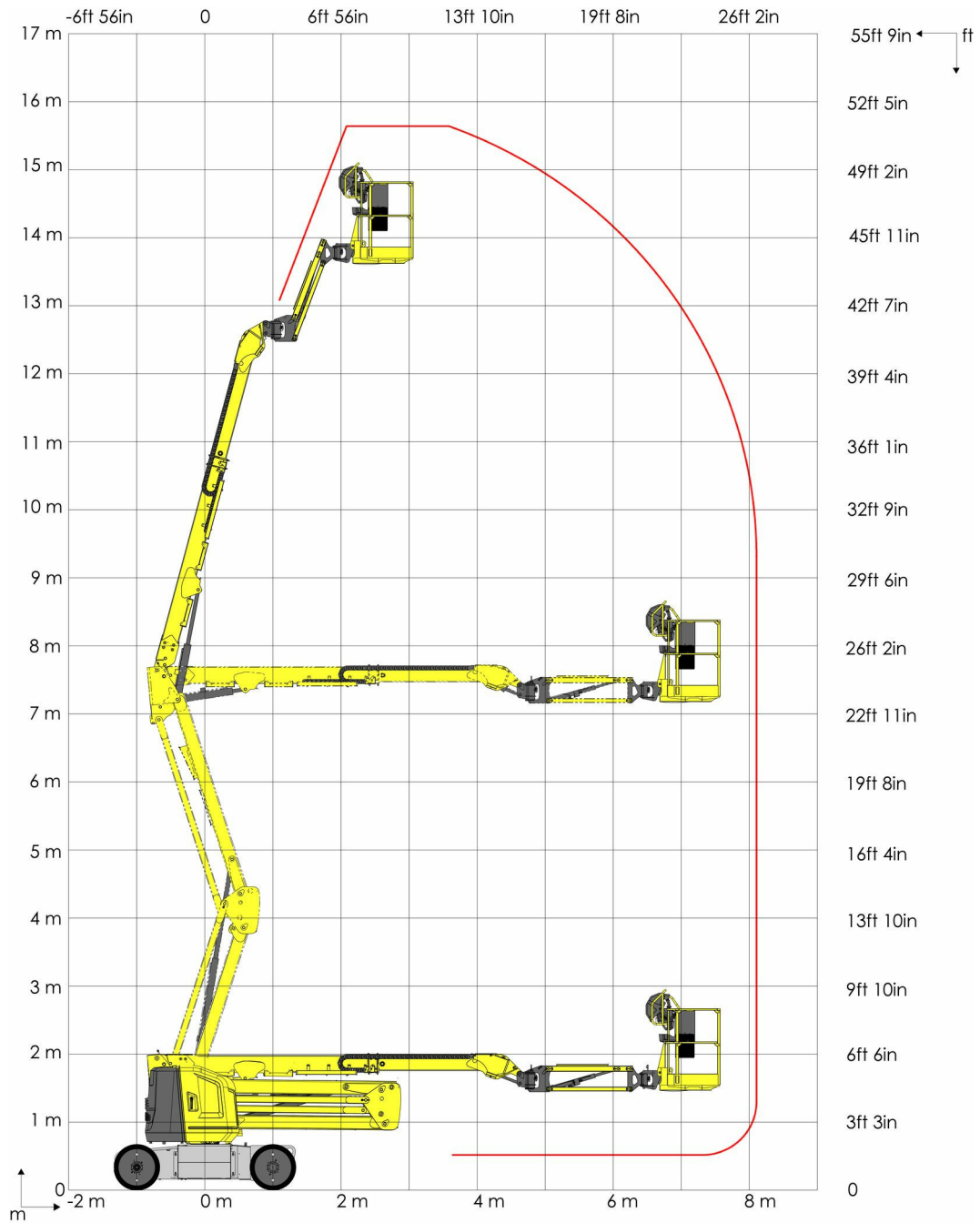

B - Familiarization

5 Decals and markings locations

CE, UKCA, AS and EAC standards - 4001102610 J - SIGMA 16

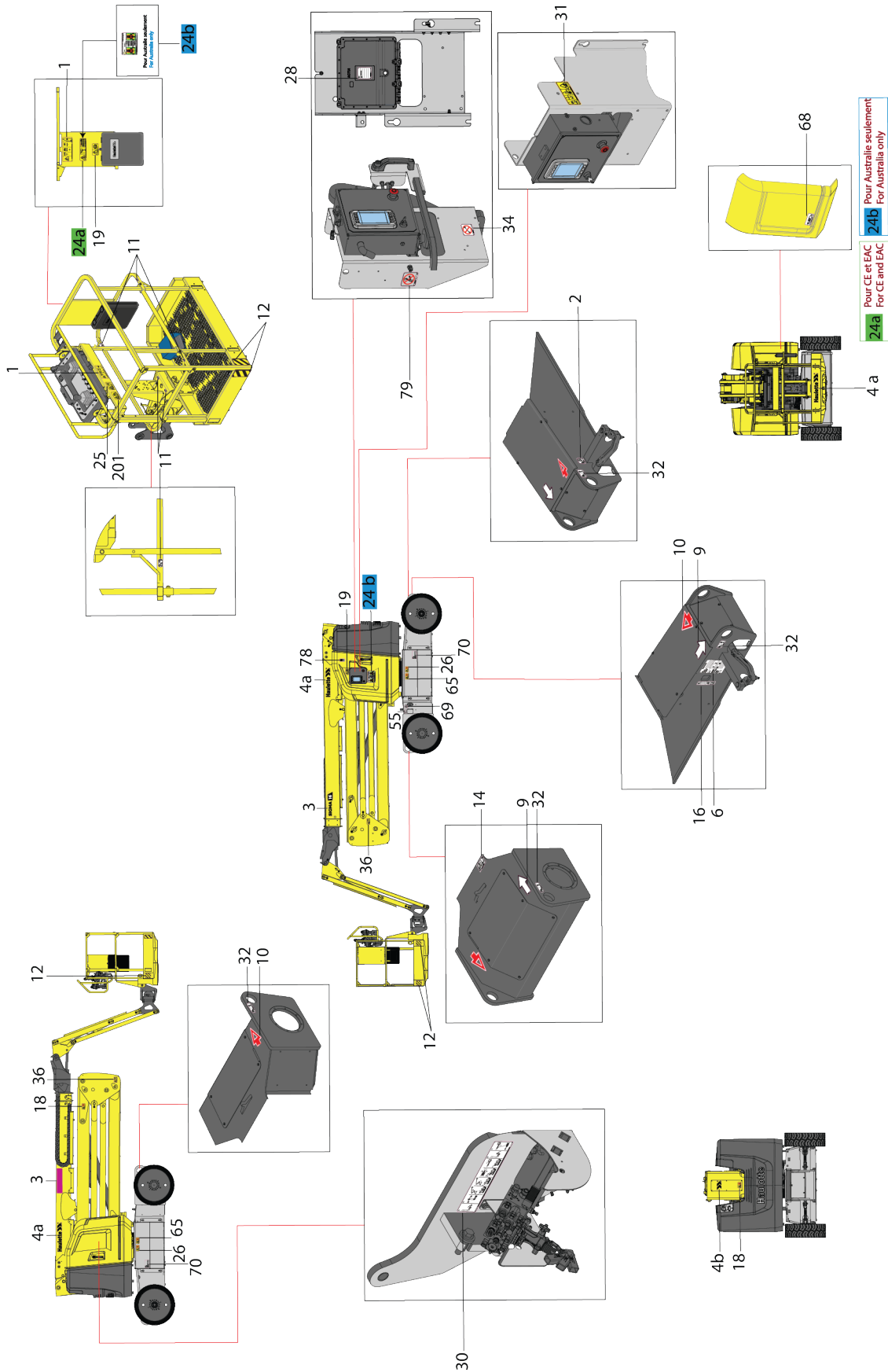

B - Familiarization

Options

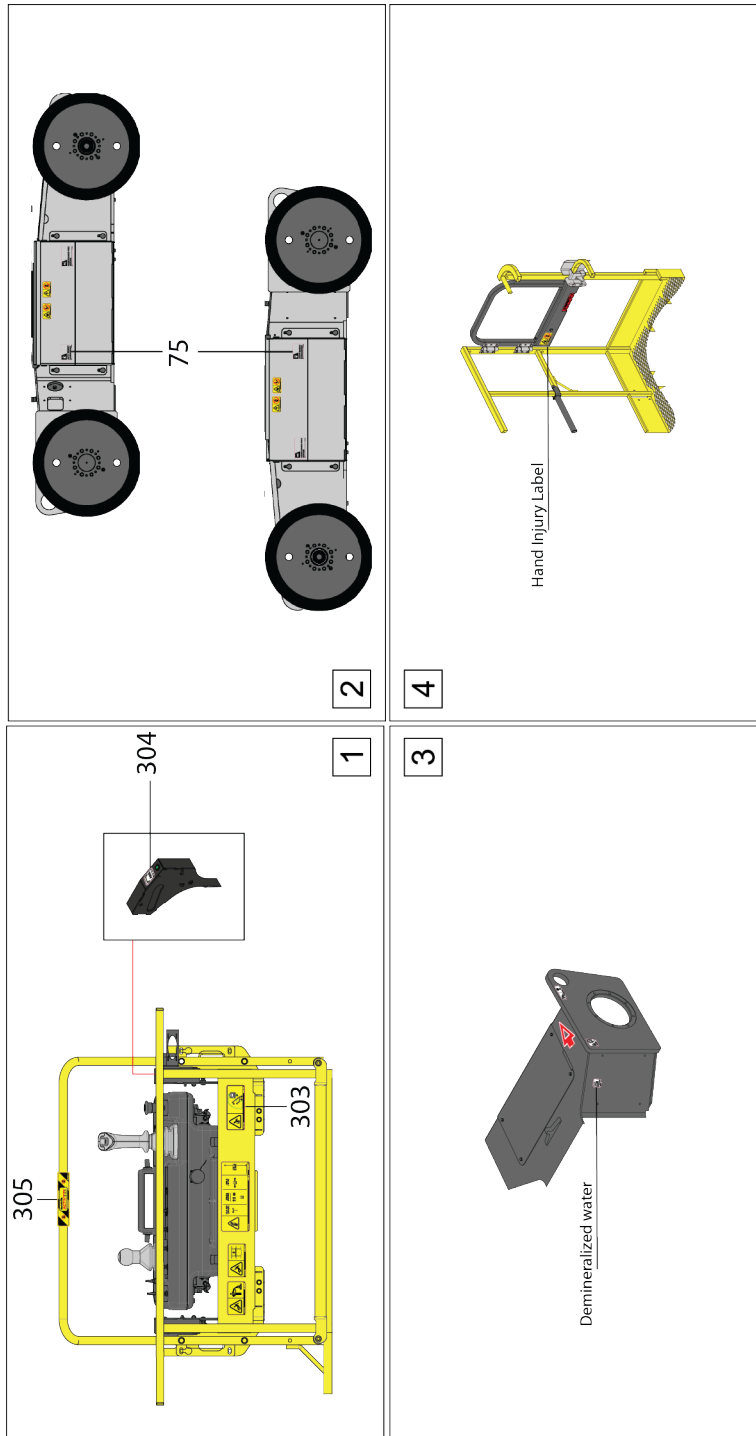

1. Activ' Shield Bar
2. Activ' Energy Management
3. Demineralized Water
4. Swing gate

B - Familiarization

Options

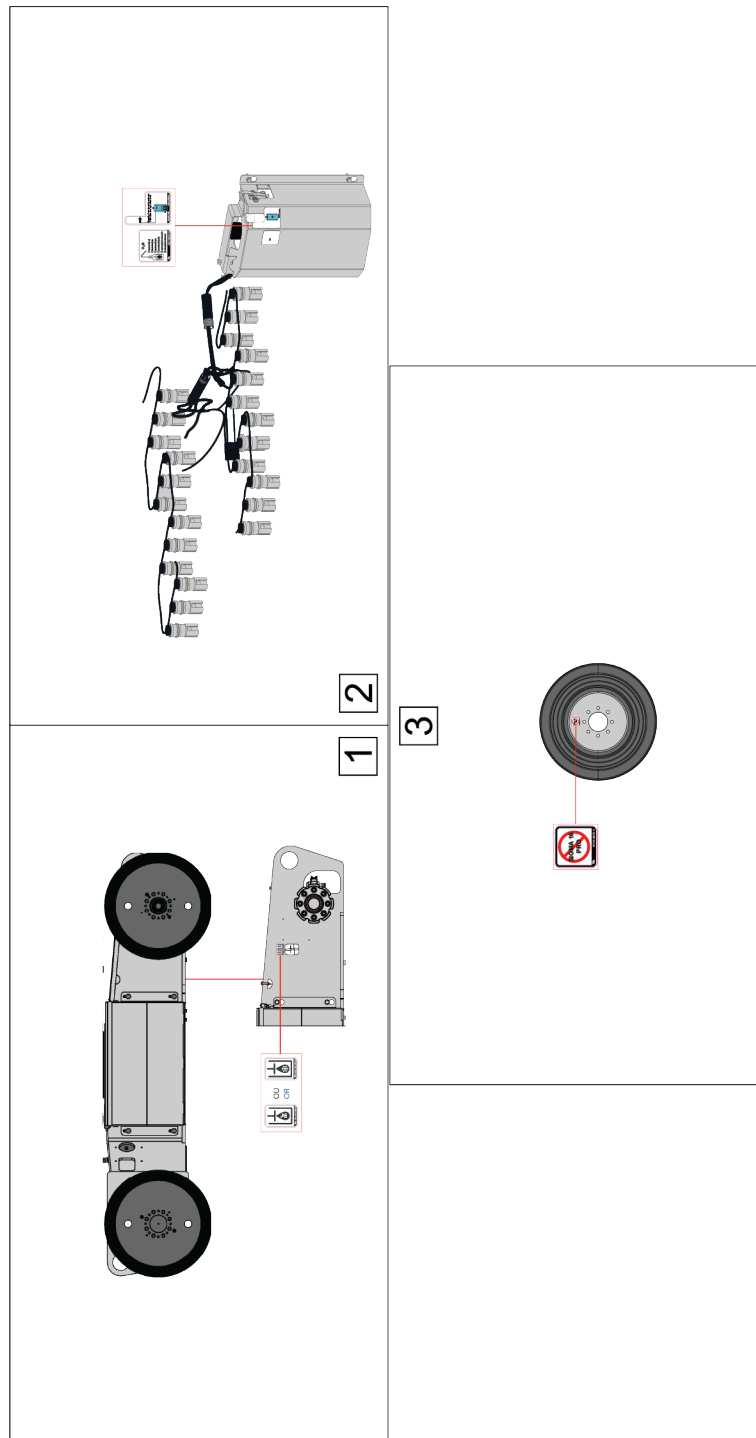

1. Biodegradable hydraulic oil option / Bio HFE 32 / Cold country
2. Automatic water filling on battery
3. Wheel Assembly (672x229 - Exmile GNM) (The wheels are forbidden for SIGMA16 PRO)

B - Familiarization

CE, UKCA, AS and EAC standards - 4001102620 I - SIGMA 16 PRO

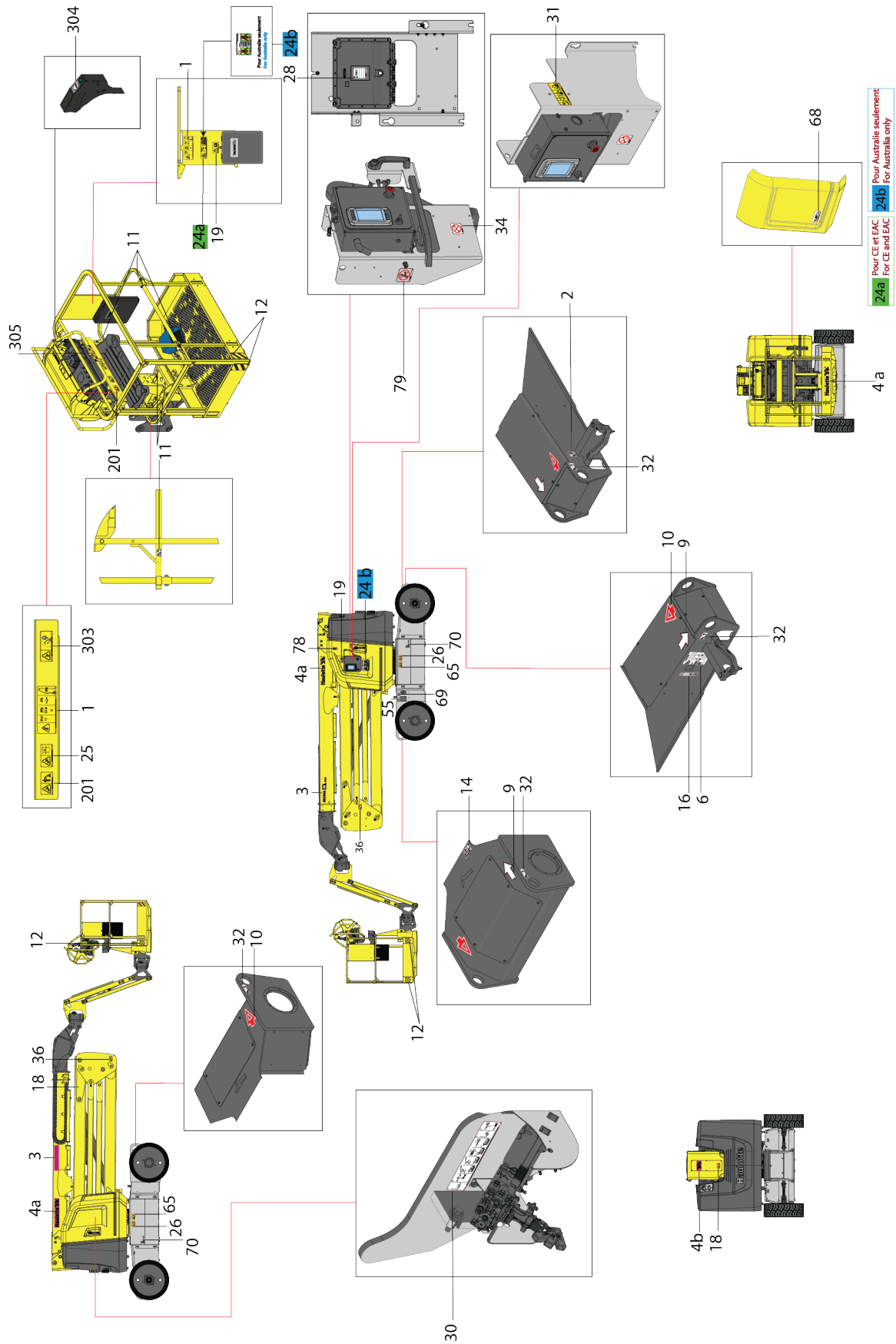

B - Familiarization

Options

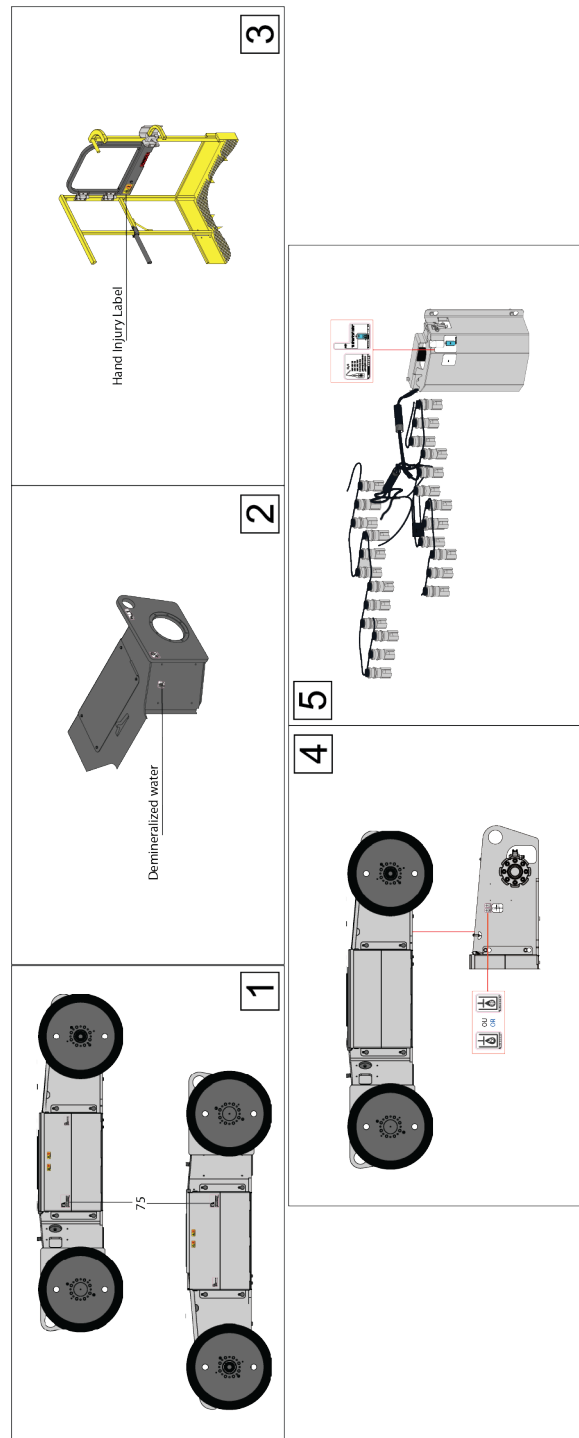

1. Activ' Energy Management
2. Demineralized Water
3. Swing gate
4. Biodegradable hydraulic oil option / Bio HFE 32 / Cold country
5. Automatic water filling on battery

B - Familiarization

CE, UKCA, AS and EAC standards

Marking	Description	Quantity	SIGMA 16	SIGMA 16 PRO
1	Height of the floor and load	2	4001082720	4001082760
2	Maximum Pressure per Tire - Floor Loading	4	4001083100	
3	Commercial name - Bright machine	2	4001082410	4001082390
3	Commercial name - Dark machine	2	4001122420	4001122430
4a	Decal HAULOTTE® - Bright machine	3	4001072210	
4a	Decal HAULOTTE® - Dark machine	3	4001072220	
4b	Decal HAULOTTE® - Bright machine	1	4001072250	
4b	Decal HAULOTTE® - Dark machine	1	4001072260	
6	Identification plate	1	4000700160	
9	Control of movements - WHITE directional arrow	2	4001083270	
10	Control of movements - RED directional arrow	2	4001083390	
11	Lanyard attachment points	6	4001052020	
12	Material risk - Yellow and black adhesive tape	3	4001083240	
12	Material risk - Yellow and black adhesive tape	2	4001083250	
14	Collision hazard - Turntable rotation locking pin	1	4001081530	
16	Max and min oil level	1	4001052060	
18	Hand crushing hazard - Risk of crushed hands	2	4001052080	
19	Operation instructions	2	4001052090	
24a	Danger of electrocution	1	For CE, UKCA and EAC standards only: 4001052120	
24b	Danger of electrocution	2	For AS standard only: 4001052140	
25	Risk of crushing - Closing drop rail	1	4001052150	
26	Danger of electrocution - Ground for welding	2	4001052160	
28	Software version	1	4000504670	
30	Hand pump	1	4001083080	

B - Familiarization

Marking	Description	Quantity	SIGMA 16	SIGMA 16 PRO
31	Brake release	1	4001083070	
32	Anchorage point - Traction	4	4001052180	
34	Risk of electrocution - Water projection	1	4001052200	
36	Risk of crushing - Emergency lowering	2	4001081590	
55	Risk of electrocution - Charger - 240 V - 15 A	1	4001074270	
65	Fire Hazard	2	4001052270	
68	Transport height	1	4001081770	
69	Battery isolation switch	1	4001073740	
70	Information - AC MAINTENANCE - FREE MOTORS - Bright machine	2	4001053450	
70	Information - AC MAINTENANCE - FREE MOTORS - Dark machine	2	4001053500	
75	Information - ACTIV' ENERGY MANAGEMENT - Bright machine	2	4001053460	
75	Information - ACTIV' ENERGY MANAGEMENT - Dark machine	2	4001053510	
78	QR Code - MyCompanion	1	4001281820	
79	Electrical connection	1	4001101260	
201	Wearing of a safety harness is essential	1	4001052300	
303	Activ' Shield Bar	1	Option - 4001081630	Standard - 4001081630
304	Activ' Shield Bar	1	Option - 4001069620	Standard - 4001069620
305	Activ' Shield Bar - Do not lean on the bar	1	Option - 4001069640	Standard - 4001069640
Not shown	Option - Demineralized Water	1	4001052340	
Not shown	Option - Swing gate	1	4001052080	
Not shown	Pipe holder option	1	4001098410	
Not shown	Option - Plate holder	1	4000131830	
Not shown	Option - Biological hydraulic oil	1	4001052380	

B - Familiarization

Marking	Description	Quantity	SIGMA 16	SIGMA 16 PRO
Not shown	Option - Cold weather oil	1	4001052390	
Not shown	Compressed air option	1	4000130880	
Not shown	Option - Automatic centralized filling	1	4001052340	
		1	4001347850	
Not shown	Option - Wheel Assembly 672X229 EXMILE GNM	1	4001329080	

B - Familiarization

ANSI and CSA standards- 4001102950 K - SIGMA 46

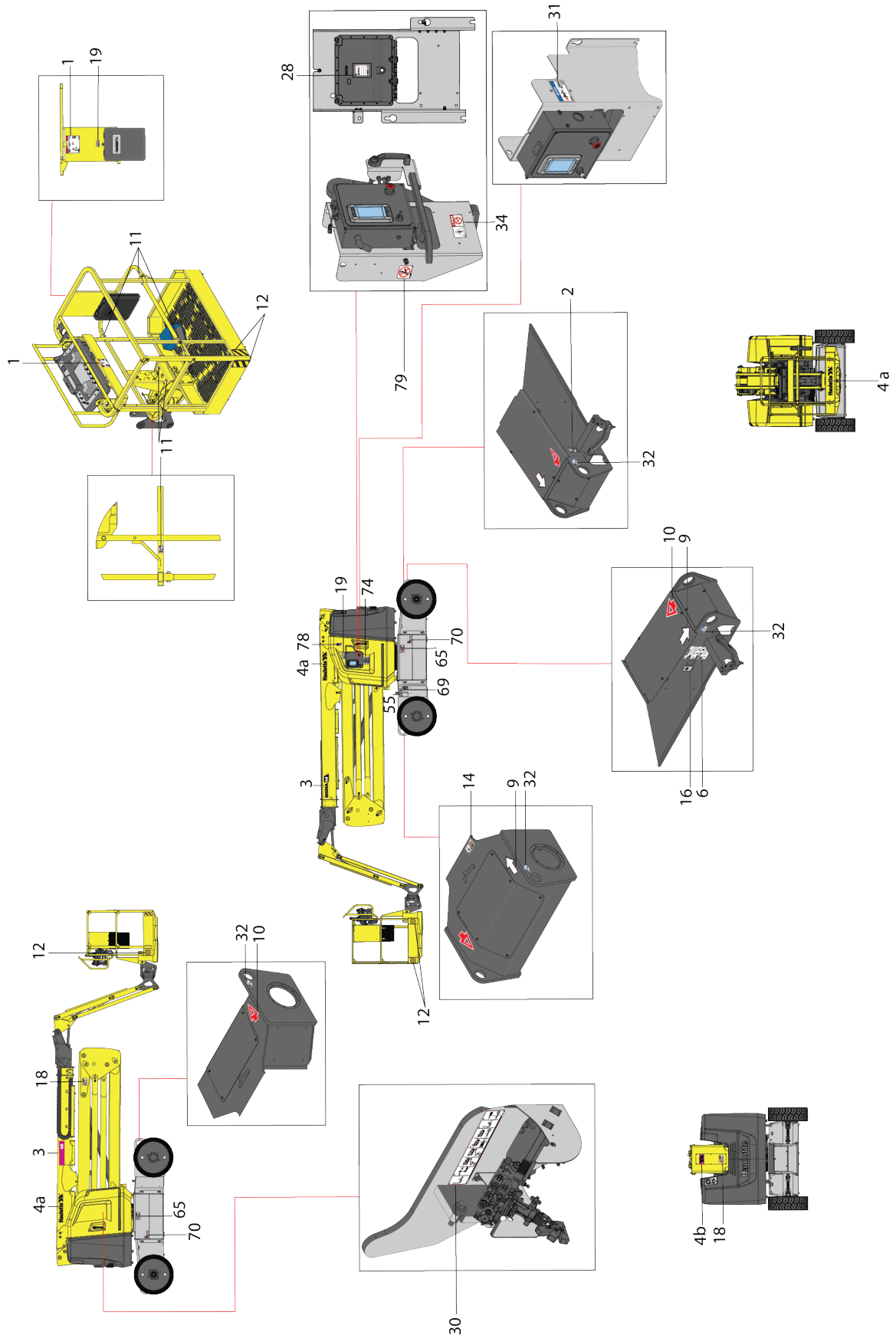

B - Familiarization

Options

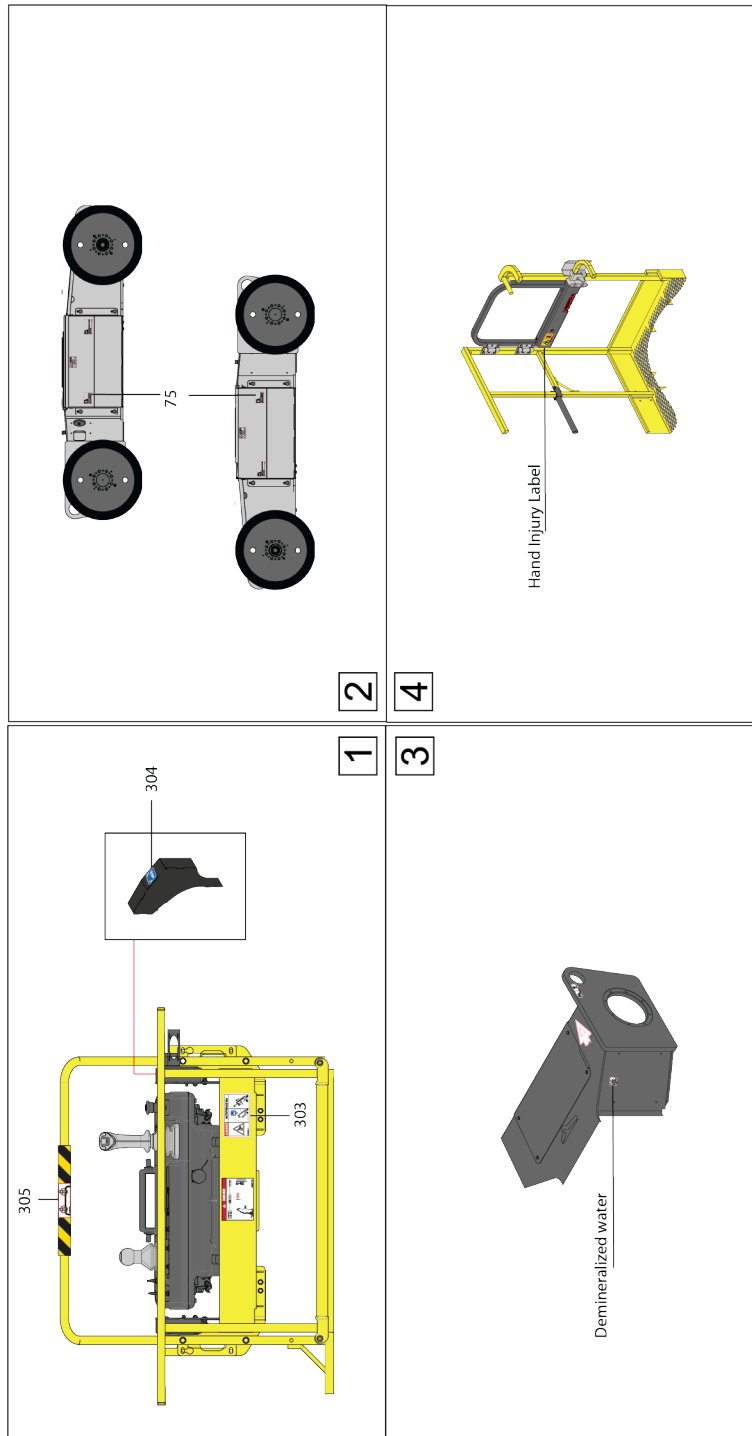

1. Activ' Shield Bar
2. Activ' Energy Management
3. Demineralized Water
4. Swing gate

B - Familiarization

Options

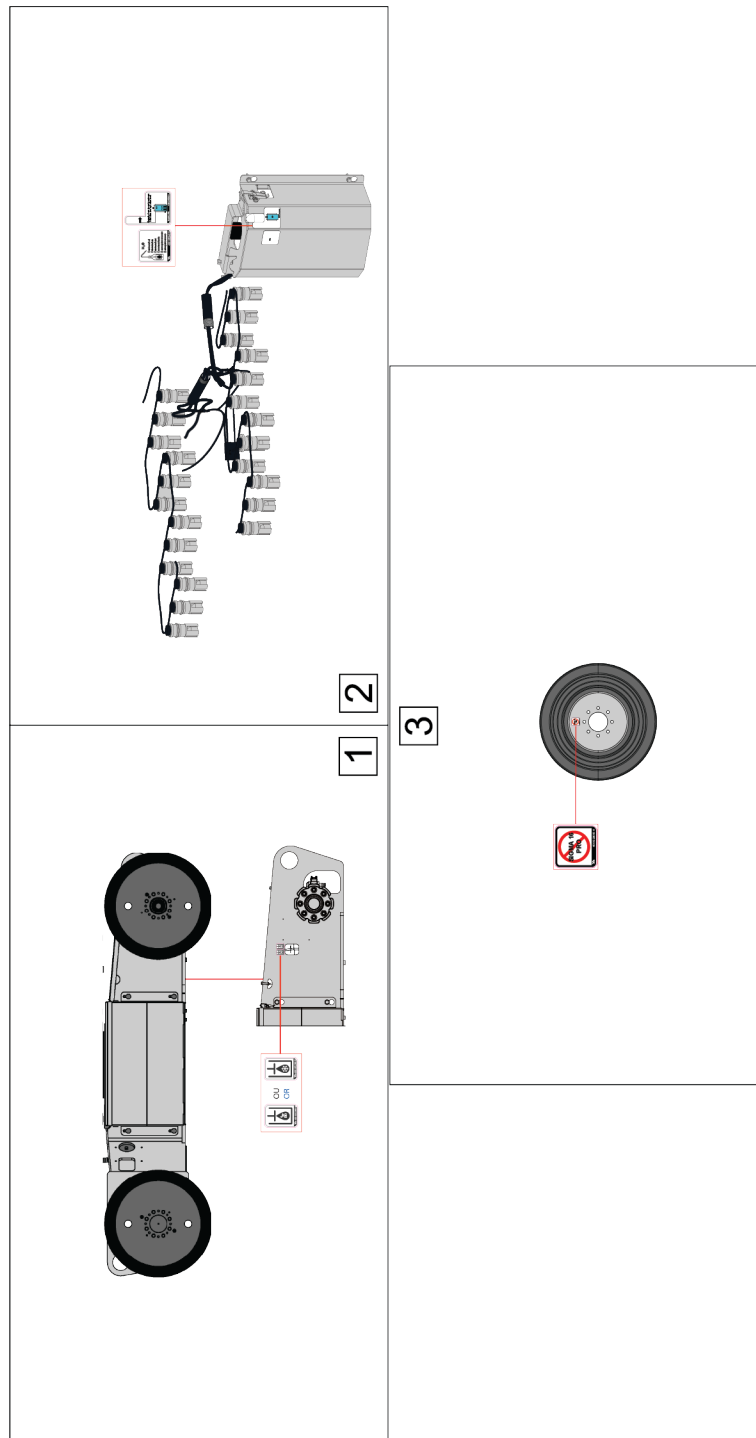

1. Biodegradable hydraulic oil option / Bio HFE 32 / Cold country
2. Automatic water filling on battery
3. Wheel Assembly (672x229 - Exmile GNM) (The wheels are forbidden for SIGMA46 PRO)

B - Familiarization

ANSI and CSA standards - 4001102960 J - SIGMA 46 PRO

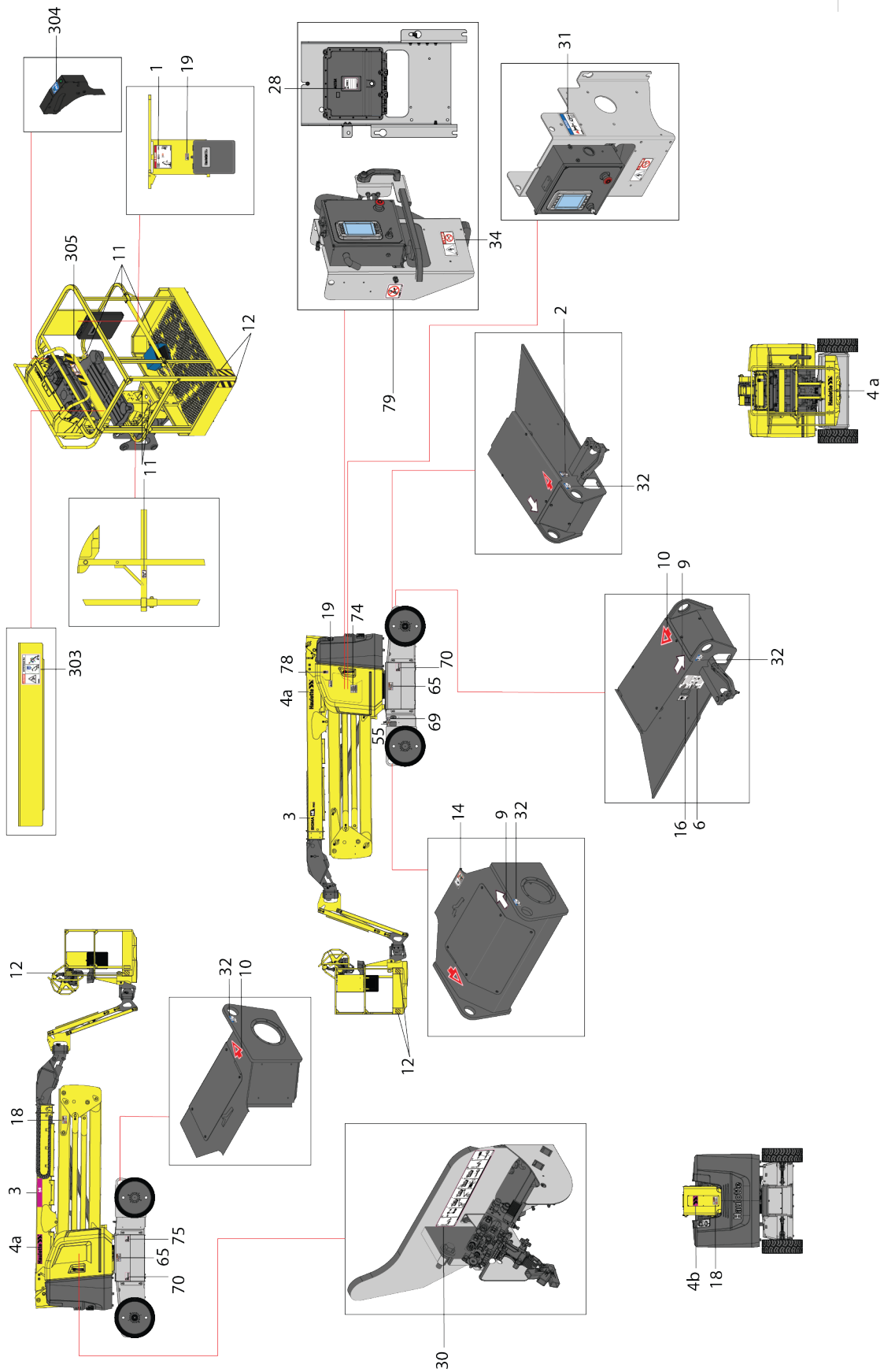

B - Familiarization

Options

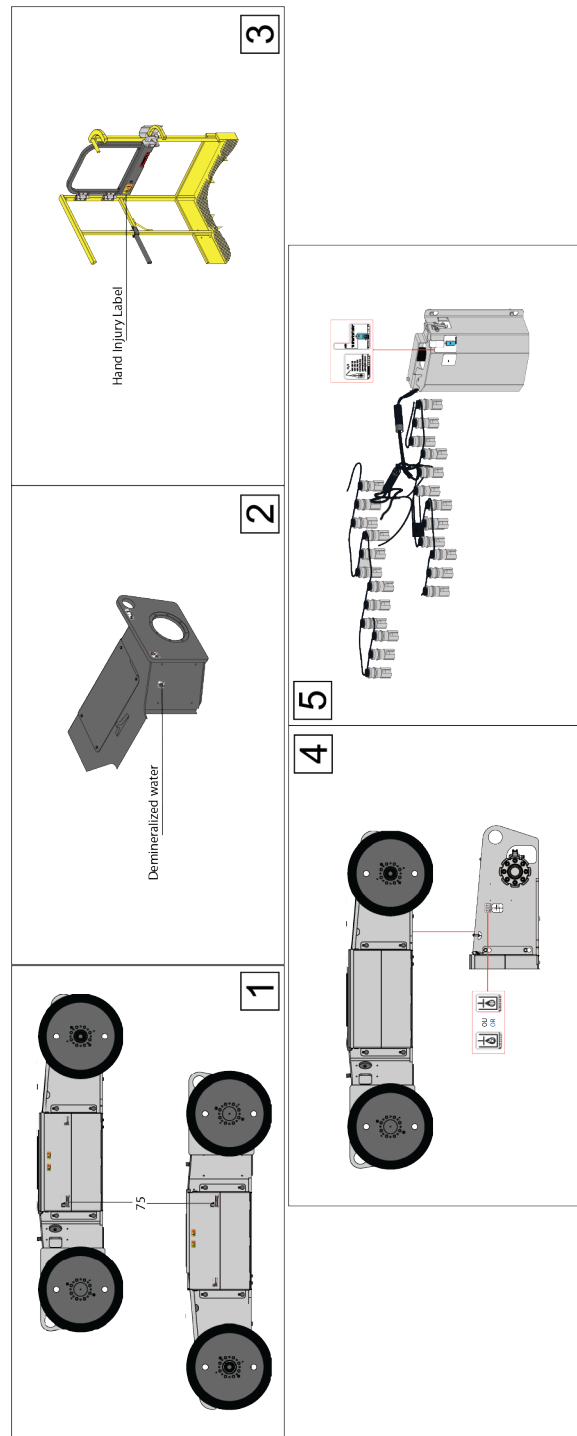

1. Activ' Energy Management
2. Demineralized Water
3. Swing gate
4. Biodegradable hydraulic oil option / Bio HFE 32 / Cold country
5. Automatic water filling on battery

B - Familiarization

ANSI and CSA standards

Marking	Description	Quantity	SIGMA 46	SIGMA 46 PRO
1	Height of the floor and load	2	4001083740	4001083780
2	Maximum Pressure per Tire - Floor Loading	4	4001083100	
3	Commercial name - Bright machine	2	4001082520	4001082460
3	Commercial name - Dark machine	2	4001082480	4001082440
4a	Decal HAULOTTE® - Bright machine	3	4001072210	
4a	Decal HAULOTTE® - Dark machine	3	4001072220	
4b	Decal HAULOTTE® - Bright machine	3	4001072250	
4b	Decal HAULOTTE® - Dark machine	1	4001072260	
6	Identification plate	1	4000700160	
9	Control of movements - WHITE directional arrow	2	4001083270	
10	Control of movements - RED directional arrow	2	4001083390	
11	Lanyard attachment points	6	4001052020	
12	Material risk - Yellow and black adhesive tape	3	4001083240	
12	Material risk - Yellow and black adhesive tape	2	4001083250	
14	Collision hazard - Turntable rotation locking pin	1	4000027080	
16	Max and min oil level	1	307P221060	
18	Hand crushing hazard - Risk of crushed hands	2	In english: 4000024770 In french: 4000067710 In spanish: 4000086490	
19	Operation instructions	2	4000025140	
28	Software version	1	4000504670	
30	Hand pump	1	4001083080	
31	Brake release	1	4000361570	
32	Anchorage point - Traction	4	4000027310	
34	Risk of electrocution - Water projection	3	4000025130	
55	Risk of electrocution - Charger - 110 V	1	4000419150	

B - Familiarization

Marking	Description	Quantity	SIGMA 46	SIGMA 46 PRO
65	Fire Hazard	2	In english: 4000025030 In french: 4000068120 In spanish: 4000086550	
69	Battery isolation switch	1	4001167960	
70	Information - AC MAINTENANCE-FREE MOTORS - Bright machine	2	4001053450	
70	Information - AC MAINTENANCE-FREE MOTORS - Dark machine	2	4001053500	
74	California warning - P65	1	4001026850	
75	Information - ACTIV' ENERGY MANAGEMENT - Bright machine	2	4001053460	
75	Information - ACTIV' ENERGY MANAGEMENT - Dark machine	2	4001053510	
78	QR Code - MyCompanion	1	4001281820	
79	Electrical connection	1	4001101260	
303	Activ' Shield Bar	1	Option - 4000609540	Standard 4000609540 -
304	Activ' Shield Bar	1	Option - 4000596720	Standard 4000596720 -
305	Activ' Shield Bar - Do not lean on the bar	1	Option - 4000206690	Standard 4000206690 -
Not shown	Option - Demineralized Water	1	4001052340	
Not shown	Option - Swing gate	1	4001052080	
Not shown	Pipe holder option	1	4001098410	
Not shown	Option - Biological hydraulic oil	1	4001052380	
Not shown	Option - Cold weather oil	1	4001052390	
Not shown	Compressed air option	1	4000130880	
Not shown	Option - Automatic centralized filling	1	4001052340	
		1	4001347850	
Not shown	Option - Wheel Assembly 672X229 EXMILE GNM	1	4001329080	

C - Pre-operation inspection

1	Recommendations.....	3
2	Working area assessment.....	4
3	Inspection and Functional test.....	5
3.1	Daily inspection.....	5
4	Safety functional checks.....	9
4.1	Emergency Stop button check.....	9
4.2	Activation of controls.....	9
4.3	Fault detector.....	10
4.4	Overload sensing system.....	11
4.5	Slope warning device.....	11
4.6	Travel speed limitation.....	12
4.7	On-board electronics.....	12
4.8	Braking test.....	12
4.9	Overload test.....	13

C - Pre-operation inspection

1 Recommendations

The owner, the site manager, the supervisor and the operator are all responsible to ensure the machine is fit for the work it is to perform; i.e. that the machine is suitable to carry out the work in complete safety and in compliance with this Operator's Manual. All managers who are responsible for persons operating the machine must be familiar with the local regulations currently applicable in the country of use and ensure that they are adhered to.

Before using the machine, read the previous chapters in this manual. Ensure that you have understood the following points:

- Safety precautions.
- Operator's responsibilities.
- Conditions and the operating principles of the machine.

C - Pre-operation inspection

2 Working area assessment

Before carrying out any operations, ensure that the machine corresponds to the work to be done and the working environment:

- Carry out a thorough inspection of the site to identify any potential risks within the work zone.
- Take the necessary precautions to avoid collisions with other machinery or people within the work area.
- Mark out the work area.
- **Ensure that:**
 - The weather conditions (wind, rain, etc.) allowing the machine to be used.
 - The ground withstands the weight of the machine and has not been affected by the poor weather conditions.
- Check that the authorisations to work with the machine on the site in question have been obtained (.g. chemical product factories).
- Define a rescue plan for all the risks, including the risk of falls and crushing.

C - Pre-operation inspection

3 Inspection and Functional test

3.1 Daily inspection

Each day before the beginning of a new work session and with each change of operator, the machine must be subjected to a visual inspection and a complete functional test.



- Never use a defective or a malfunctioning aerial work platform.
- If any item on the check list is marked "No" during the inspection; machine must be tagged and placed out of service.
- Do not operate the machine until all identified items are corrected and it has been declared safe for operation.

In case of loose fasteners, refer to torque table value in maintenance book.

In case of leaks, replace the damaged part before use.

In case of structural part deformation (cracks, broken weld, paint chips) replace the part before use.



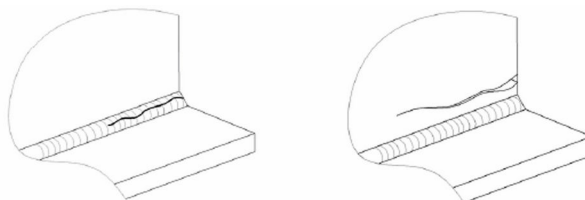





Examples of cracked welds



We recommend these forms to be completed daily and stored to assist with your maintenance schedule.

Each action is depicted in the daily inspection sheet using the following symbols.









Use the detailed program below.

	Oil change		Lubrication-Lubrication		Tightening
	Levelling		Systematic replacement		Functional adjustments / Checks / Cleaning
	Visual inspection		To check by test		

Serial number: Hours of operation: HAULOTTE Services® contract reference: Intervention record number: Date: Name:	Model: Signature:
--	----------------------













C - Pre-operation inspection

Electric articulated platforms







Haulotte	Daily	OK	NOK	Corrected	Comments
Chassis assembly: Wheel, reducer, steering, wheel pivot					
Check state of tires/tyres and inflations					
Check that the ground strap is present and in good condition					
Batteries					
Check the condition of the battery					
Turntable					
Test the operation of the turntable locking system					
Hydraulic : oils, filters and hoses					
Check the hydraulic oil level (Top up the oil if necessary ; Machine stowed)					
Check the hoses, blocks and pumps, fittings, cylinders and the tank for the absence of leaks, deformations and damage					
Platform					
Ensure that the gate or sliding bar shall be designed to either return automatically to the closed and latched position					
Check that the harness anchor points are not cracked or damaged					

C - Pre-operation inspection

Electric articulated platforms

	Daily	OK	NOK	Corrected	Comments
General					
Check for the presence, cleanliness and readability of the manufacturer's plates, security labels, user manual and maintenance manual					
Check the cleanliness and readability of the control box					
Test the opening and closure of covers (chassis, turntable, upper control box)					
Check the condition of electrical harnesses, cables and connectors					
Check for the absence of abnormal noise and jerky movements					
Check for the absence of visible deterioration and damage					
Check for the absence of cracks, broken welds and chipped paintwork on the structure					
Check for the absence of missing or loose screws and bolts					
Check for the absence of deformation, cracking and breakage of axis stops, bushing and axes					
Check for the absence of foreign bodies in joints and sliding parts					
Safety devices					
Test the operation of the upper and lower control boxes: manipulators, switches, buttons, horn, emergency stops, screens and lights					

C - Pre-operation inspection

	Daily	OK	NOK	Corrected	Comments
Test the operation of visual and audible alarms					
Check the absence of visual and audible alarms					
Test the operation of the Emergency manual lowering system					
Test the operation of the loading control system (visual alarm on the control box)					
Test the operation of the Activ Shield Bar (If equipped)					

C - Pre-operation inspection

4 Safety functional checks

To protect the user and the machine, safety systems prevent the movement of the machine beyond its operating limits. These safety systems when activated immobilize the machine and prevent further movement.

The operator must be familiar with this technology and understand that is not a malfunction but an indication that the machine has reached an operation limit.

The aerial work platforms are fitted with a platform control box (main control box) and a ground control box (emergency control box) enabling users to use the machine safely. An auxiliary system (Overriding system) is available on the ground control box in order to rescue anyone trapped on the platform.

The following checks describe the operation of the machine and the specific controls required.



For the location and description of these controls: refer to section B 3.2 and D 2 - Ground control box and B 3.3 and D 3 - Platform control box.

4.1 Emergency Stop button check

Ground control box Emergency Stop button

Step	Action
1	Pull the Emergency Stop button (9) at the ground control box.
2	Set the key switch (21) at ground box to the  position.
3	The indicator (10) lights up on ground control box.
5	Push the Emergency Stop button (9).
6	Check that the screen and the LED 10 switch off.
7	Check no movements are functional.

Platform control box Emergency Stop button

Step	Action
1	Pull both Emergency Stop buttons (9) at ground box and (46) at platform box.
2	Set the key switch (21) at ground box to the  position.
3	The indicator (13) lights up on ground control box.
4	Push in Emergency Stop button (46) at platform.
5	Check that the indicators go out.
6	Check no movements are functional.

4.2 Activation of controls

The enable foot pedal (enable switch) must be activated to allow any movement.

The "Enable Switch" system depends on the machine configuration and will consist of one of the following:

- Enable switch at ground box (6).

C - Pre-operation inspection

- Foot pedal (enable switch) in the platform (C42).

N.B.-:THE ENABLE SWITCH MUST BE ACTIVATED FIRST BEFORE ANY ACTION ON THE JOYSTICK OR SWITCHES.

4.3 Fault detector

The machine is equipped with an on-board fault detection system, which indicates the type of fault to the operator.

The fault is identified by a default code.

The default code is displayed at the ground control box.

According to the type of fault, the machine MAY switch into DOWNGRADEMODE mode and certain movements are prevented to maintain Operator's safety.

Do not use the machine until the fault has been corrected.

4.3.1 Indicators/LED's test

From the ground control box

Step	Action
1	Pull the Emergency Stop button (9) at the ground control box.
2	Set the key switch (21) at ground box to the  position
3	Check that the LEDs (10, 13, 15, 16) and that the touch screen (22) light up.
4	Check that the LED's (13, 15, 16) on the display are all turned off after 1 sec.

From the platform control box

Step	Action
1	Pull the Emergency Stop button (9) at the ground control box.
2	Pull the Emergency Stop button (46) at the platform control box
3	Set the key switch (21) at ground box to the  position
4	Check that the LEDs (10, 13, 15, 16) and that the touch screen (22) light up.
5	First push in the Emergency Stop button (46) at platform box, then pull out.
6	Check that the LED's (110, 111, 112, 114, 116) light up on the platform display panel.
7	Check that the LED's (110, 111, 112, 114, 116) on the display are all turned off after 1 sec.

C - Pre-operation inspection

4.3.2 Buzzers test

From the ground control box

Step	Action
1	Pull the Emergency Stop button (9) at the ground control box.
2	Set the key switch (21) at ground box to the  position.
3	Verify that the buzzers at the ground and platform beep.

4.4 Overload sensing system

If the platform load exceeds the maximum allowed load, no movement is possible from the 2 control boxes. At ground and platform control boxes a buzzer sounds and an indicator light warns the operator.

To return the machine to normal operation remove weight from the platform until the load is below the maximum allowed load.

Daily check that the LED's illuminate when the machine is switched on:

- Verify that the Overload system is active: Refer to Indicator (15) at ground control box and LED (114) at platform control box display.
- Verify that the buzzers are functioning: Refer to  Buzzers test.

A periodic inspection of this device must be performed according to the recommendation in  Maintenance Schedule.

4.5 Slope warning device

From each control box, a buzzer alerts the operator that the machine is not folded/stowed and is positioned on a slope exceeding the slope allowed.

N.B.-:THE SLOPE SENSOR IS ONLY ACTIVE WHEN THE PLATFORM IS NOT IN THE STOWED POSITION.

When machine is on a slope greater than the rated slope, with extending structure out of the stowed position:

- The DRIVE and LIFTING (RAISING) commands are deactivated.

The lowering speeds are reduced.

In this case, fully lower the platform and reposition the machine on level ground before raising the platform again.



Do not rotate the turret while on a slope greater than 10%. Ensure boom is positioned between the wheels.

To check the tilt sensor at ground level, perform the following steps:

C - Pre-operation inspection

To check the tilt sensor at ground level

Step	Action
1	Put the machine in stowed position.
2	Position the machine on an incline that is greater than the maximum permitted incline ( B 4.1 - Technical specifications) .
3	Check that the "tilt" LED 112 indicator is lit up.
4	Lift the platform. Ensure the movement is stopped.
5	Buzzers at ground and platform will beep.

4.6 Travel speed limitation

Drive Speed Selector switch (45) at the platform control provides a 2 speed selection (high or low).

All driving speeds are authorised when extending structure of the machine is in stowed position (transport configuration). Drive speed is proportional to the movement of the drive joystick (33). Adjust position of Jib to enhance field of vision during driving.

Whatever the position of the drive speed selector switch (45) on the platform control box, the drive speed is limited when the machine is unfolded.

Daily check that the speed is limited to less than 0,5 km/h (0.3 mph) when:

- The boom is raised by more than 10° above horizontal.
- The boom is telescoped/extended more than 400 mm (16 in).
- The arm is raised by more than 2 m (6 ft 7 in) above horizontal.

The electronic variable speed unit controls movement and driving speed.

It receives information from the control joystick concerning the movements to be performed.

It also manages the safety systems status.

Poor knowledge of the characteristics and operation of the machine can lead the operator to think that a normal safety operation is a malfunction.

N.B.-:IF HIGH-SPEED DRIVE IS SELECTED AND THE MACHINE IS MOVING ON A SLOPE GREATER THAN 12,5°, THE DRIVE SPEED IS AUTOMATICALLY REDUCED.

4.7 On-board electronics

The machine is equipped with a specific calculator configured for this machine's functionalities.

Do not interchange calculators between machines, as this may result in the loss of parameters, settings, calibrations, and render the machine inoperable.

4.8 Braking test



Check that there are no hazards in the test area:

- Position the machine on a flat and firm surface, clear of obstructions (beware of power lines).
- The machine must be completely stowed.
- Ensure that there is sufficient distance to stop the machine in complete safety.
- Position the steered wheels so that they are straight.
- To set up a beaconing of safety around the test area.
- Personal fall protection equipment (PFPE) is compulsory to carry out this test.

C - Pre-operation inspection





Platform control box

Step	Action
1	Pull both Emergency Stop buttons; at ground box and at platform box.
2	Turn the ground control box selector key to platform control box position.
3	Select low drive speed , then slowly move the drive joystick.
4	Drive the machine forward in low speed on a ramp inclined at less than the maximum authorized slope.
5	Release joystick.
6	The machine comes to a complete stop. Keep the machine immobilized for 5 seconds.
7	Check the ability of the brakes to keep the machine immobilized. The machine must remain immobile.

4.9 Overload test

The overload system is an essential part of machine safety. The following tests must be performed periodically-

You will need:

 <ul style="list-style-type: none"> - Personal protective equipment - DO NOT OPERATE tag - Standard tool kit - Lifting equipment adapted and suitable for placing and removing the load from the platform - 2 loads of 100% and 120% of the nominal load: Refer to section B  - Technical specifications. 	 <ul style="list-style-type: none"> - Place barriers around the perimeter of the work area 		
	1 person		

Procedure:

Platform control box

Step	Action
1	Position the machine on a flat and firm surface, clear of obstructions (beware of power lines).
2	Start the machine.
3	Put the machine in stowed position.
4	Mark out the work area (barriers, cones, marking tape) .
5	Restrict access to the area (restricted access sign).
6	Place a do not operate tag at the start/stop switch location to inform personnel that the equipment is being worked on.

C - Pre-operation inspection

Step	Action
7	Use external lifting equipment to position 100% of the nominal load in the center of the platform.
8	From the ground control box: Check that there is no overload alarm.
9	Remove the weight from the platform.
10	Use external lifting equipment to position 120% of the nominal load in the center of the platform.
11	Check that the overload/fault indicators are lighted on the 2 control boxes.
12	Check that the overload alarms are displayed on the screens of the 2 control boxes.
13	Remove the load from the platform.

D - Operation instructions

1	Operation.....	3
1.1	Introduction.....	3
1.2	Major description.....	3
1.3	Operation from the ground control box (Service / Emergency station).....	3
1.4	Operation from the platform control box (Main station).....	4
2	Ground control box - Service / Emergency station.....	6
2.1	To start and stop the machine.....	6
2.2	Movement control.....	6
2.3	Additional controls.....	8
3	Platform control box - Main station.....	9
3.1	To start and stop the machine.....	9
3.2	Drive and steer control.....	9
3.3	Movement control.....	10
3.4	Additional controls.....	12
4	Rescue and emergency procedures.....	14
4.1	Main power supply failure.....	14
4.2	To rescue operator in platform.....	15
4.3	Operation of overriding system from ground control box.....	15
5	Transportation.....	16
5.1	Transport configuration.....	16
5.2	Machine stowage for transport -SIGMA 16 - SIGMA 46 - SIGMA 16 PRO - SIGMA 46	
PRO	16
5.3	Unloading.....	18
5.4	Towing.....	18
5.5	Storage.....	19
5.6	Lifting operation.....	20
6	Cold Weather Recommendations.....	22
6.1	Hydraulic oil.....	22
7	Battery care and maintenance.....	23
7.1	Battery recharge.....	23
7.2	Battery care and maintenance.....	26
7.3	Optimise battery life.....	29

D - Operation instructions

1 Operation

1.1 Introduction

Only trained and authorized personnel shall be permitted to operate this aerial work platform.

Prior to operation:

- Read, understand and obey all instructions and safety precautions in this manual and attached to the aerial work platform.
- Read, understand and obey all local regulations.
- Become familiar with the proper use of all controls and emergency systems.

1.2 Major description

All the machines are equipped with:

- Platform control box.
- Ground control box.



- An Emergency Stop button is present at each control box.
- The Emergency Stop button at the ground control box stops all movements when pressed in.
- The Emergency Stop button at the platform control box stops all movements when pressed in and the platform control box is selected. The Emergency Stop button at the platform control box is neutralized when the ground control box is selected.

1.3 Operation from the ground control box (Service / Emergency station)

The ground control box is designed for maintenance and emergency rescue operations only.

- Turning "ON" and "OFF" of the machine is performed with the Control box activation key switch (21).
- Activation of a desired control box is achieved by turning the Control box activation key switch (21) to



the desired position .

- The ground control box is energized and is active ONLY when:
 - The emergency stop on the ground control box is not pushed in.
 - The machine is switched on.
 - Ground control box is selected.

N.B.-:DO NOT TURN OFF THE POWER SUPPLY OF THE MACHINE USING THE EMERGENCY STOP BUTTON (USE ONLY IN CASE OF EMERGENCY). TURN OFF THE POWER SUPPLY OF THE MACHINE USING THE CONTROL BOX



ACTIVATION KEY SWITCH (21) TO POSITION.

- An Enable Switch (6) provided must be activated and maintained to authorize one or more function movements. If Enable Switch (6) is kept engaged without selecting a function movement for more than 8 s; Enable Switch is automatically de-activated.

N.B.-:THE ENABLE SWITCH (6) MUST BE ACTIVATED FIRST BEFORE ANY ACTION ON THE JOYSTICK OR SWITCHES.

- Drive and steer movements are not possible from the ground control box.
- All switches and joystick operating a movement, return automatically to neutral when released.
- Overriding system: The ground control box is an auxiliary control box to use in emergencies only. Refer to  D 4.2 - To rescue operator in platform.
- The status of the switches is tested automatically when the machine is switched on. A switch will be active only after it has been detected to be in neutral position. The following switches are not controlled:
 - Beacon light (if fitted)
- A buzzer beeps in the following conditions:
 - When power is switched on.

D - Operation instructions

- Overload.
 - Slope if machine is out of stowed position.
 - Hydraulic oil overheating.
 - Movement buzzer option.
 - Drive buzzer option.
- Indicators: Indicators (10), (13), (15) and (16) are checked when the machine is powered on.

1.4 Operation from the platform control box (Main station)

- The platform control box is energized only when:
 - The Emergency Stop buttons on both ground and platform control boxes are not pressed in.
 - The platform control box is selected.
- A faulty joystick is not taken into account to control a movement. If this fault disappears, the movement is authorised again.

N.B.-:DO NOT TURN OFF THE POWER SUPPLY OF THE MACHINE USING THE EMERGENCY STOP BUTTON (USE ONLY IN CASE OF EMERGENCY). TURN OFF THE POWER SUPPLY OF THE MACHINE USING THE CONTROL BOX



ACTIVATION KEY SWITCH (21) TO POSITION.

- A Foot Switch (C42) is present and should be activated and maintained to authorize one or more movements. If Foot Switch is kept engaged without selecting a function movement for more than 8 s seconds ; Enable switch is automatically de-activated.

N.B.-:THE ENABLE SWITCH (C42) MUST BE ACTIVATED FIRST BEFORE ANY ACTION ON THE JOYSTICK OR SWITCHES

N.B.-:IT IS RECOMMENDED THAT OPERATOR REMOVES THE FOOT FROM THE FOOT SWITCH WHENEVER A MOVEMENT HAS CEASED.

- The release of control box enable switch while performing a movement stops all the movements. The stop of movements is progressive.
 - If the Foot Switch is pressed again quickly within 0,5 s the movement restarts.
 - If the Foot Switch and / or Enable Switch is not pressed again quickly enough within + 0,5 s the movement will not restart. It could restart only when the selected function switch/joystick is released to neutral position.
- All switches and joystick operating a movement, return automatically to neutral when released.
- At power up, all switches and joysticks must be in their neutral position.
- The status of the switches is tested automatically when the machine is switched on and checked at every starting. A switch will be activated only after it has been detected in neutral position.
- A manual emergency pump is available in case the machine's main energy source fails ( D 4.1 - Main power supply failure) .
- Indicators: All indicators (LEDs 110, 111, 112, 114, 116) are checked when the machine is powered on.
- A buzzer beeps in the following conditions:
 - When power is switched on.
 - Overload.
 - Slope if machine is out of stowed position.
 - Hydraulic oil overheating.
 - Movement buzzer option.
 - Drive buzzer option.

D - Operation instructions



While driving on a slope:

- While driving, always place the boom above the rear axle, in the direction of movement.
- Always orientate the machine in the direction of the slope.
- Always place the boom in fully retracted and in stowed position.
- Always place the basket down.
- Do not travel down slopes in high speed.
- Do not drive fast in narrow or cluttered areas. Keep the speed under control.

D - Operation instructions

2 Ground control box - Service / Emergency station

2.1 To start and stop the machine

- Check that the Emergency Stop buttons (9) at ground control box and (46) at platform control box are not pressed in.



- Turn the control box selector (21) to position  to energize the ground control box.

To shut-down the machine from the ground control box



- Turn the activation selector key switch (21) to off position .
- Power supply is now switched off.

N.B.:-THIS OPERATION TURNS OFF THE POWER SUPPLY TO MACHINE AND IT IS REQUIRED TO PREVENT BATTERY DISCHARGE.

N.B.:-THE TOUCHSCREEN AUTOMATICALLY GOES INTO STANDBY IF IT IS NOT USED FOR AN EXTENDED PERIOD. TO SWITCH THE TOUCHSCREEN BACK ON, TURN THE KEY SELECTOR TO THE OFF POSITION THEN FOLLOW THE START-UP PROCEDURE.

N.B.:-THE TOUCHSCREEN STOPS A FEW SECONDS AFTER THE POWER IS SWITCHED OFF.

2.2 Movement control

Even at low movement speeds, use the controls with caution.









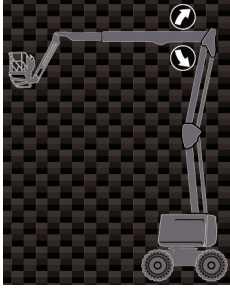

N.B.:-RELEASING THE ENABLE SWITCH (6) WILL STOP ALL MOVEMENTS.

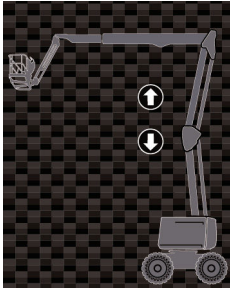
Activate the desired control and the 'Enable switch' (6) simultaneously to perform that selected function.

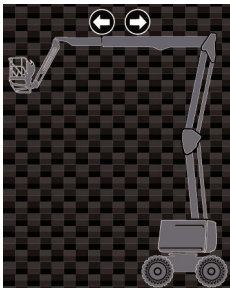

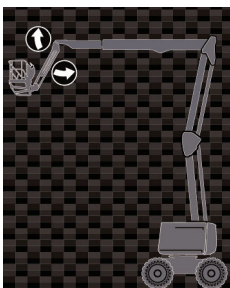

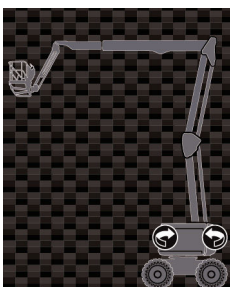

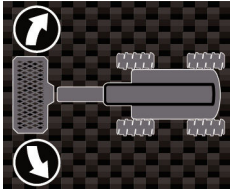

N.B.:-THE ENABLE SWITCH (6) MUST BE ACTIVATED FIRST BEFORE ANY ACTION ON THE JOYSTICK OR SWITCHES

D - Operation instructions

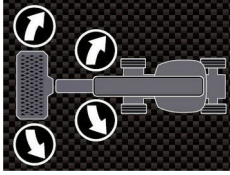
Ground box controls (emergency station)

Command		Action
Raising / lowering of boom		Press the boom raising control (4)  to raise the boom.
		Press the boom lowering control (4)  to lower the boom.
Raising / lowering of arm		Press the arm raising control (5)  to raise the arm.
		Press the arm lowering control (5)  to lower the arm.
Boom telescoping extend / retract		Press the boom telescoping control (3)  to extend the boom.
		Press the boom retracting control (3)  to retract the boom.
Jib raising / lowering		Press the jib raising control (2)  to raise the jib.
		Press the jib lowering control (2)  to lower the jib.
Turntable rotation		Press the turntable rotation control (7)  for a clockwise (CW) rotation. Press the jib rotation control for an anti-clockwise rotation
		Press the turntable rotation control (7)  for a counter-clockwise (CCW) rotation.

D - Operation instructions

Command		Action
Platform rotation		Press the platform rotation control (8)  for a clockwise (CW) rotation.
		Press the platform rotation control (8)  for a counter-clockwise (CCW) rotation.
Jib rotation (If equipped)		Press the jib rotation control (23)  for a clockwise rotation
		Press the jib rotation control (23)  for an anti-clockwise rotation
Platform leveling		Press the platform levelling control (1)  to tilt the platform upwards Press the platform levelling control (1)  to tilt the platform downwards

2.3 Additional controls

For the machines equipped with beacon light:

- Press the beacon light selector switch (14) to turn ON the beacon light.
- Press the beacon light selector switch (14) to turn OFF the beacon light.
- Push the horn selector (12) to the right to sound the horn. The horn stops when the selector switch is released.

D - Operation instructions

3 Platform control box - Main station

3.1 To start and stop the machine

3.1.1 To start the machine

At the ground control box

- Check that the Emergency Stop button (9) is not pressed in.

- Turn the control box activation key selector (21) to platform control box position  to switch on the platform control box.

At the platform control box

- Check that the Emergency Stop button (46) is not pressed in.
- The power on LED (101) at the platform display lights up.

3.1.2 To stop the machine

- Push in the Emergency Stop button (46).

- Turn the activation selector key switch (21) to off position .

The machine's power supply can only be turned OFF from the ground control box by turning the control box

activation key selector (21) to the OFF  position.



The touchscreen automatically goes into standby if it is not used for an extended period. To switch the touchscreen back on, press the emergency stop button then follow the start-up procedure.

3.2 Drive and steer control

To activate drive and steer function, press the Foot Switch and simultaneously operate the joystick (33) for the desired function.







N.B.-:-THE ENABLE SWITCH (C42) MUST BE ACTIVATED FIRST BEFORE ANY ACTION ON THE JOYSTICK OR SWITCHES.

Before moving, locate the white and red directional arrows on the chassis and the platform control box.

Move the drive control joystick (33) in the direction matching the directional arrows.

N.B.-:-ON UNEVEN TERRAIN, LOWER THE BOOM TO IMPROVE THE DRIVE PERFORMANCE.

D - Operation instructions

Command		Action
Steering		Press thumb/rocker switch on joystick (33 A) to the right to steer right.
		Press thumb/rocker switch on joystick (33 B) to the left to steer left.
Driving		Move joystick (33) forwards for the machine to travel in the forward direction (WHITE directional arrow) .
		Pull joystick (33) backwards for the machine to travel in the reverse direction (RED directional arrow) .
Drive speed		Position the drive speed selector switch (45) on  for high-speed driving.
		Position the driving speed selector (45) on  for low-speed driving (short distance, final approach, unloading from lorries/trucks).

3.3 Movement control

N.B.-:THE ENABLE SWITCH (C42) MUST BE ACTIVATED FIRST BEFORE ANY ACTION ON THE JOYSTICK OR SWITCHES.

N.B.-:RELEASING THE ENABLE SWITCH (C42) WILL STOP ALL MOVEMENTS.

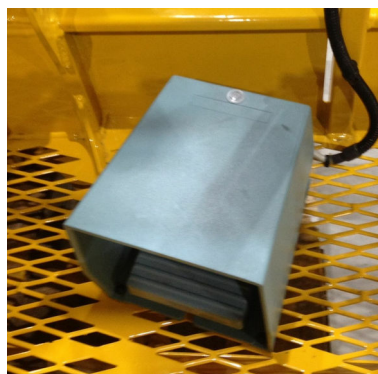

Foot Switch

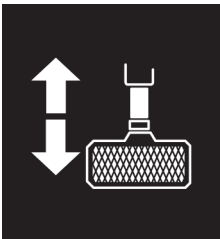
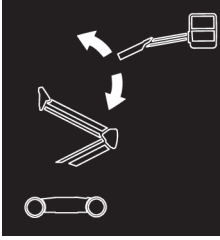
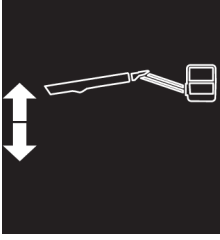
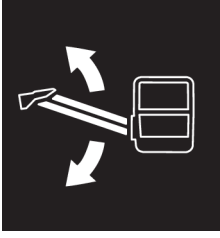
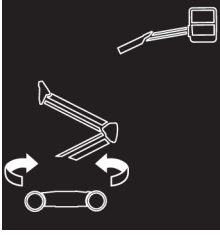

D - Operation instructions

Command		Action
Boom telescoping extend / retract		Push the boom telescoping switch (54) upwards to retract the boom.
		Push the boom telescoping switch (54) downwards to extend the boom.
Boom raising / lowering		Move the boom/turntable joystick (49) forward to raise the boom.
		Move the boom/turntable joystick (49) backwards to lower the boom.
Arm raising / lowering		Push the arm raise / lower selector (50) upwards to raise the arm.
		Push the arm lift/lower selector (50) downwards to lower the arm.
Jib raising / lowering		Push the jib switch (129) upwards to raise the jib.
		Push the jib switch (129) downwards to lower the jib.
Turntable rotation		Move the boom/turntable joystick (49) to the left for a clockwise (CW) rotation.
		Move the boom/turntable joystick (49) to the right for a counter clockwise (CCW) rotation.

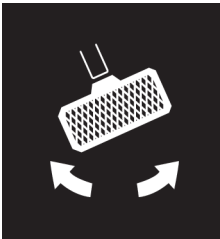
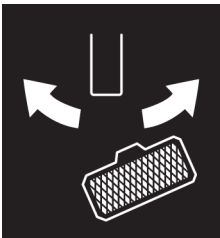
D - Operation instructions

Command		Action
Platform rotation		Move the platform rotation switch (38) to the left for a clockwise (CW) rotation.
		Move the platform rotation switch (38) to the right for a counter clockwise (CCW) rotation.
Jib rotation (If equipped)		Push the jib rotation selector switch (83) to the left for a counter clockwise (CCW) rotation
		Push the jib rotation selector switch (83) to the right for a clockwise (CW) rotation
Platform leveling		Move the platform levelling switch (40) upwards to raise the platform to the front of the machine.
		Move the platform levelling switch (40) downwards to tilt the platform to the rear of the machine.

3.4 Additional controls

- Horn: Push the horn selector (43) to the right to sound the horn. The horn stops when the switch is released.

3.4.1 Activ' Lighting System

Refer to  B 3.3 - Platform control box.

This option means that the operator will be able to safely load (or unload) the machine onto the truck.

Located on the turntable, boom and platform, the Activ' Lighting System system lights up the controls and surrounding areas of the machine. Users can then safely move the machine.

3.4.2 Drive Orientation Assist system (If equipped)

Drive Orientation Assist is a secondary prevention and driving assistance system.

The system completes the choice of drive direction via the white and red directional arrows located on the chassis and the upper control panel.

When the turret rotates more than 60° to the left or right:

- The system alerts the operator of the turret orientation.
- Drive release is required to enable movement.

D - Operation instructions

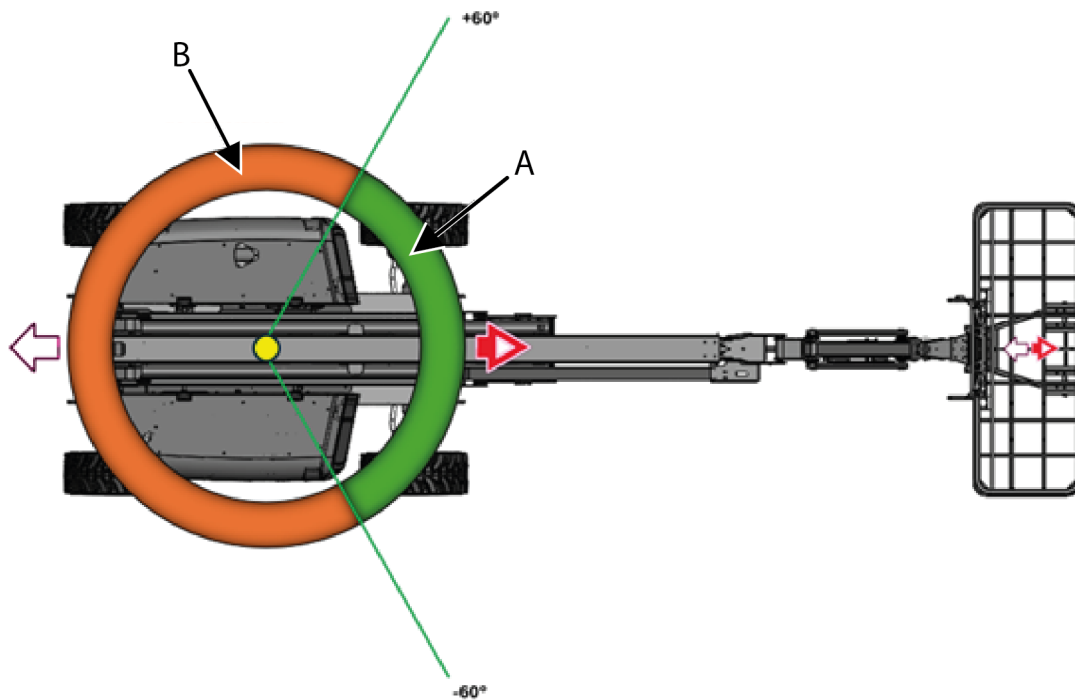

Marking	Description
A	Unrestricted area: Area without drive restriction
B	Restricted area: Area with drive release

Unrestricted area:

In this area, the drive function is allowed. The selector (263) and indicator light (264) are inactive.

Restricted area:

The indicator light (264) is lit in this area. To authorize driving, the operator must:

- Determine the driving direction of the machine using the white and red directional arrows.
- Push the selector (263).
- Slowly move the joystick (33) in the desired direction.

If the operator attempts to perform a drive movement while selector (263) has not been activated, indicator light (264) flashes, and an audible alarm (2 beeps) sounds.

N.B.: -IF THERE IS NO ACTION ON THE JOYSTICK (33) FOR 8S, DRIVE RELEASE IS CANCELLED. THE OPERATOR MUST REACTIVATE THE SELECTOR (263) TO AUTHORIZE MOVEMENT.

D - Operation instructions

4 Rescue and emergency procedures

4.1 Main power supply failure

If the main energy source (electricity) fails, a hand pump located next to the hydraulic distributors on the turntable is used to perform a manual descent.

This pump can be used in combination with manual control of the solenoid valve block assembly to perform the following movements

- Arm lift down.
- Boom descent.
- Turntable rotation.
- Jib raising / lowering.



This procedure is exclusively reserved for lowering in emergency situations only.



All safety functions are inoperative and hazardous situations may occur. Improper use of equipment will result in death or serious injuries.

4.1.1 Procedure

- Make sure the tap (1) is closed.
- Insert the lever (2) in the return bend of the pump (3).
- Push the lever from top to bottom several times whilst holding down the manual control of the solenoid valve block (4) for the required movement as shown on the label (30) (Please refer to paragraph B.5 -Decals and markings locations).

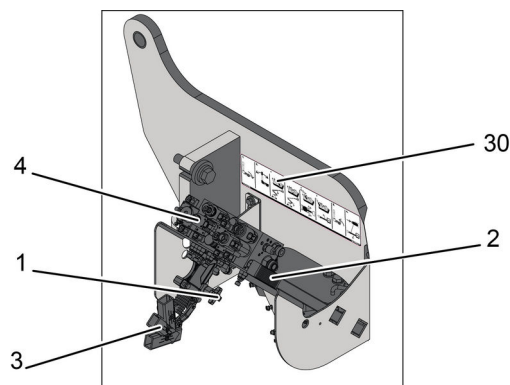

Manual repair-Marking(30)

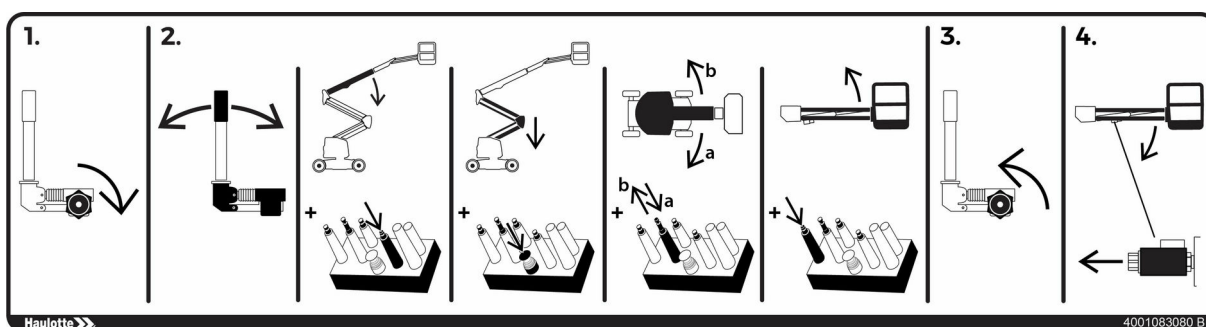

In an emergency, if the operator has to exit the platform while it is elevated, the transfer of the platform occupant(s) must respect the following recommendations

- Exit onto a sturdy and safe structure.
- Allowance must be made for the possibility of boom deflection when egressing from the platform.
- The occupant(s) must ensure that 2 lanyards are used for security/safety. One must be attached to the designated anchorage point on platform the occupant(s) is in and the other attached to the structure intended to get on.
- Do not leave the platform without having taken into account the possibility that it may move during transfer of the occupants.

D - Operation instructions

- Occupant(s) must exit the current platform through the normal access.



Do not detach the lanyard from the current platform if the transfer to the new structure poses any danger or until the transfer is safely completed. Do not attempt to climb down from the platform. Wait for assistance to leave the cradle safely.



If the operator cannot be lowered by any of the above mentioned methods, contact HAULOTTE Services® immediatly.

4.2 To rescue operator in platform

In a situation where an operator located in the platform needs to be rescued (for example in case of illness, injury or trapped against a structure making the control box inaccessible), the rescue personel at ground level needs to obtain rapid and direct access to operating functions.

HAULOTTE® has implemented a control system for safely lowering the operator to the ground in the event of an emergency to enable him to receive the necessary treatment.



The system allows occupant(s) to be lowered to the ground level, even if an Emergency Stop is engaged or if an overload is detected.







4.3 Operation of overriding system from ground control box

N.B.:-A SAFETY DEVICE DOES NOT ALLOW NORMAL MOVEMENT FROM THE GROUND CONTROL BOX, USE THE OVERRIDING SYSTEM.



Operation of the "overriding system" switch must be an exception. The system is only active in case of overload.

Procedure

- Press and hold the "overriding" system control (11) .
- Press simultaneously the telescoping boom control (3)  to retract the boom.
- Press the boom raising control (4)  to raise or  lower the boom.
- Press the arm raising control (5)  to raise or  lower the arm.

N.B.:-ONCE RESCUE OPERATIONS ARE COMPLETE, WRITE AN INCIDENT REPORT.

D - Operation instructions

5 Transportation

5.1 Transport configuration



During loading, ensure that:

- The loading ramp can support the machine weight.
- The loading ramp is correctly attached to transport vehicle.
- The loading ramp has sufficient grip surface.
- The transport vehicle must be parked on a level surface and must be secured to prevent rolling away while machine is being loaded or unloaded.
- The floor of the transport truck and/or the trailer can bear the weight of the machine.



Do not place yourself below or too close to the machine during loading.

The machine must be completely in the stowed configuration:

- Check the platform is completely empty.

To climb the slope, select low driving speed.

If the slope is too steep, use a winch in addition to the low speed drive.

- Ensure that the jib is raised as necessary to give ground clearance when driving the machine onto the loading ramp.
- Drive onto the truck bed slowly. While constantly checking the wheel position.
- Secure the machine to the tie down points provided ( Section D - Machine layout) .
- Lock the turntable with the rotation stop pin located under the turntable before transporting ( Section D - Machine layout) .
- The platform/basket must be chocked and the boom strapped to prevent bouncing up and down, thus preventing possible material damage during transporting.
- Do not use excessive downward force when securing boom section.



A wrong move can lead to machine tipping over and may cause serious injuries and material damage.



Always align the boom in the axis of the machine and climb slopes with the platform lowered and on the downhill side of the machine.



To enter or exit from the platform: Falling Hazards ( A 2.1.2) .

5.2 Machine stowage for transport -SIGMA 16 - SIGMA 46 - SIGMA 16 PRO - SIGMA 46 PRO

Turntable rotation pin - Locked



D - Operation instructions

Turntable rotation pin - Unlocked



Machine stowing

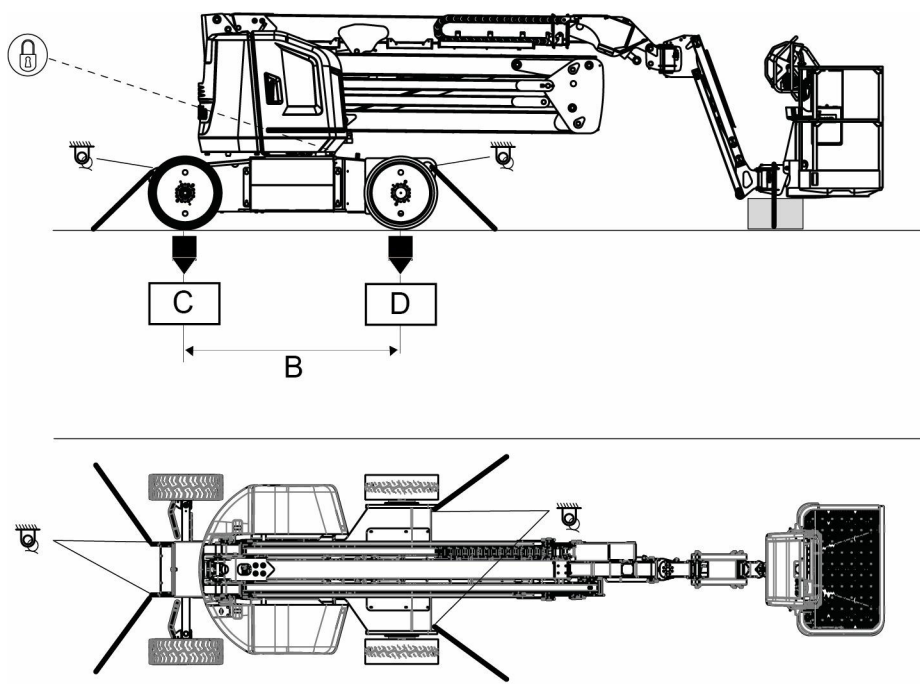

N.B.:-SECURE THE TURNTABLE WITH THE TURNTABLE LOCKING PIN BEFORE HAULING THE MACHINE ON A TRUCK.

N.B.:-THE JIB CYLINDER LOWERS BY GRAVITY AND DOES NOT ALLOW THE PLATFORM TO BE FOLDED UNDER THE BOOM. THE ONLY TRANSPORT POSITION IS ACHIEVED WITH THE PLATFORM IN ACCESS POSITION.

Loading characteristics

Marking	Description	SIGMA 16 - SIGMA 46	SIGMA 16 PRO - SIGMA 46 PRO
B	Lateral distance between the wheels		2 m (6 ft 7 in)
C	Front wheel ground pressure		13,7 daN/cm ²
D	Rear wheel ground pressure		13,7 daN/cm ²
	Anchorage point		

D - Operation instructions

5.3 Unloading

Before unloading, check that the machine is in good condition and that it has not suffered any damage during transport.

- Remove the turntable rotation locking pin ( Section D - Machine layout).
- Remove the tie downs.
- Select low drive speed at the platform control box.
- Start the machine from platform control box.



Upon starting a machine that has been secured and transported, the safety system may detect a false overload preventing all movement from the platform control box.

To reinstate the system, lift the jib a few centimetres (inches) using the ground control box.

5.4 Towing



In the event of a machine breakdown, the machine can be towed a short distance to load it onto a transport vehicle:

- Ensure that no one is in the platform during towing.
- Ensure boom is in the stowed position and the turntable is locked, prior to towing.
- The platform must be empty.

To tow a broken-down machine, release brake (Refer to  D 5.4.1 - Brake release) .

In the towing configuration, the machine braking system is inactive. Use a drawbar to avoid any risk of accident:

- Do not exceed the maximum freewheel speed (Refer to  B 4.1 - Technical specifications) .
- To go up or down a slope, use the appropriate winch.



Perform these operations on flat, horizontal ground. Block the wheels to immobilize the machine. The machine is in free wheel mode, so the braking system is not active.

5.4.1 Electric brake release

To tow a broken-down machine, the brakes can be released using the electric system.



Perform these operations on flat, horizontal ground. Failing that, block the wheels to immobilize the machine. During brake release operation, the machine is in free wheel mode and the brake system no longer functions.



When travelling over obstacles or a ramp, the use of an adapted winch is obligatory.

If the machine needs to be towed, the drive wheels brake release is located inside the right-hand compartment (ground control box side).

D - Operation instructions

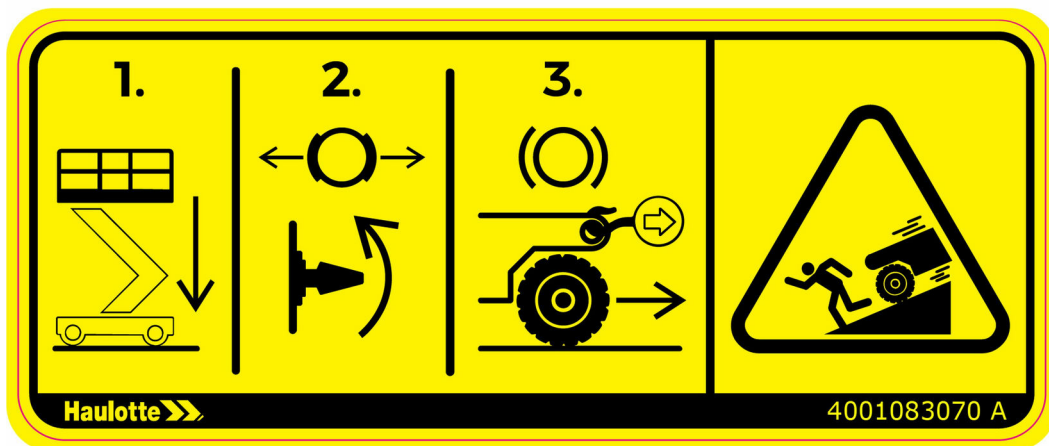
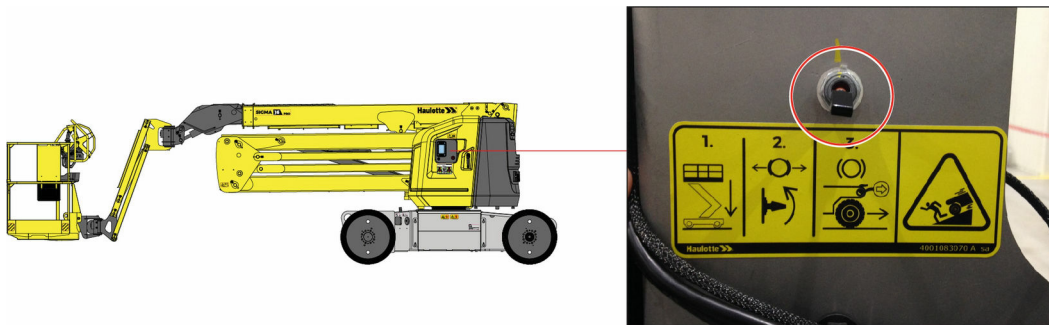

To release the machine's brakes, the following conditions must be met:

- The platform control box or the ground control box must be selected.
- The machine must be completely stowed.
- No movement selected.
- The machine must not be tilted.

Procedure

- Open the turntable cover. The brake release switch SA103 is located on the right of the ground control box.
- Hold brake switch upwards to activate the brake release.
- Hold down the brake release switch for more than 3 s. An audible signal (beep) sounds.
- Releasing the switch releases the brakes.

Brakes are applied automatically

- When the brake release switch is pressed again,
- When a command is sent from the lower or platform control box,
- The machine is turned off,
- Or the control box in use is changed.

N.B.: - IF THE USER IDENTIFICATION OPTION IS ACTIVE, THE IDENTIFICATION CODE MUST BE ENTERED TO ACTIVATE THE BRAKE RELEASE.

5.5 Storage



The machine can be stored in a designated area when not in use. If it is stored for more than 3 months without being used, an inspection must be carried out before it is put back into service.



Keep the batteries charged. Refer to  Section D - Optimise battery life.

D - Operation instructions

Machine must be parked in a protected/designated area with the boom in a stowed configuration, however the boom can be raised but must not be extended. Make sure there is no load in the platform.

Do not store or immobilise the machine when it is unfolded.

Ensure all access panels, doors and side compartment covers are shut and secured.

Turn the control box activation key switch (21) at the ground control box to the extreme left  to shut OFF the power.

Ensure that the turntable rotation locking pin is shifted to the disabled position (Refer to  D 5.2 - Machine layout).

Remove the ignition key to prevent unauthorized operation of the machine.

Turn off the circuit breaker (Opened position).



Storing of the machine with an obstacle under the boom structure is forbidden.



To avoid any risk of corrosion on rods of cylinders during a storage period of more than 1 month:

- In a normal atmospheric environment: perform a complete cycle for the cylinders every 2 months while they are in storage.
- In harsh environments (high levels of salinity in the atmosphere: close to the sea, industrial environment with chloride emissions and/or humidity >70%), we recommend applying the following protection process:
 - Wash and rinse the entire machine with plenty of clean water.
 - Dry all the cylinder rods using an air gun.
 - Apply a solvent-based oil leaving an oily film after evaporation of the solvent directly to all rods left exposed when the machine is in storage position.
 - Re-apply the product every month.



After washing the machine, make sure it is fully air-dry and does not contain moisture on corrosive parts (cylinders rods for example). Do not wash electrical components with a high pressure washer. Wipe away dirt from around electrical components with a dry cloth.

5.6 Lifting operation

During loading / unloading operation with an overhead crane, it is important to respect the following

- Put the machine in stowed position, boom and arm fully retracted and lowered.
- Platform must be empty.
- Align the turntable with the chassis, jib in lowered position and boom horizontal.
- Lock the turntable with the rotation stop pin located under the turntable.
- Verify that lifting attachments are in good operating condition and match the technical specifications. Lifting devices must be attached only to the designated lifting eyes.
- Each of the slings used for lifting the machine must be adjusted to keep the machine level and to minimize the risk of damage to the machine.



- Anchorage point for lifting are identified / labeled by the following symbol .
- ONLY trained and authorized personnel should attempt to lift the machine.



Never lift the machine with slings attached to counterweight.

D - Operation instructions

Procedure for the use of slings

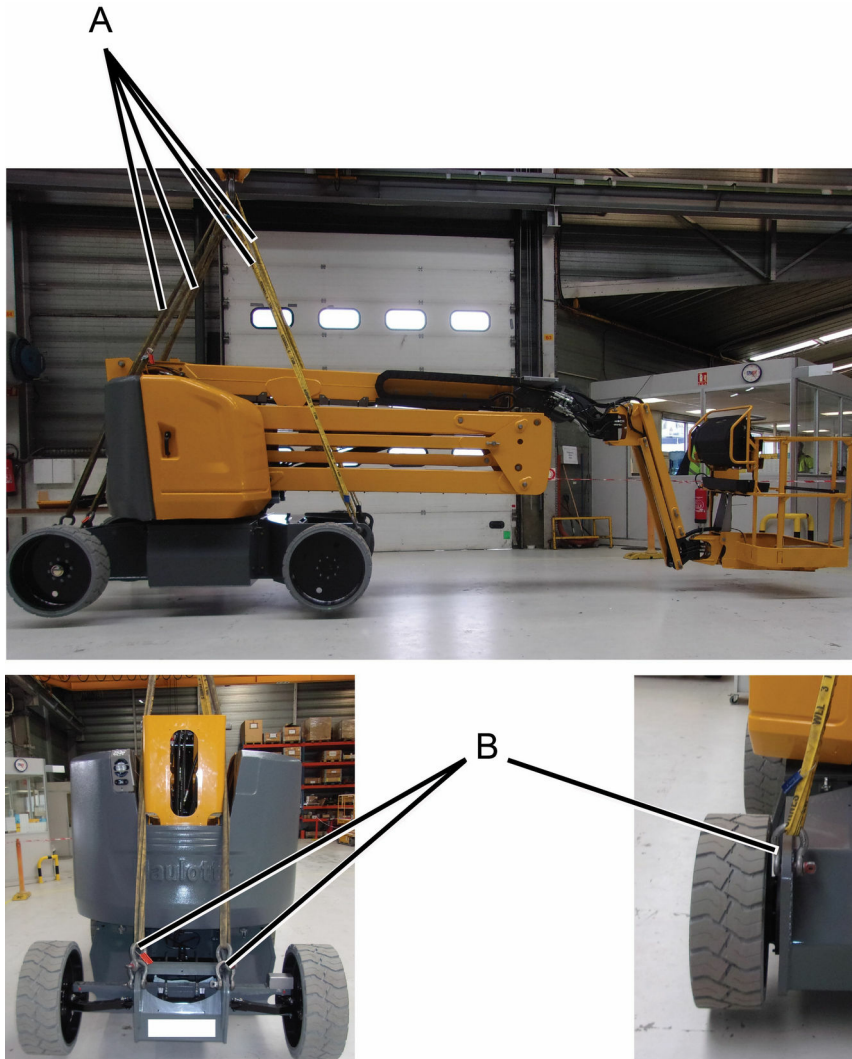

		Strap		Shackle	
	Number of slings	Minimum length	Minimum capacity	Number of shackles	Minimum capacity
A	4	3 m (9 ft 10 in)	3 T (6614 lbf)		
B				4	3 T (6614 lbf)



The 4 slings must be the same length.

D - Operation instructions

6 Cold Weather Recommendations

In extreme cold conditions, machines should be equipped with optional cold start kits.



In cold weather, do not store the machine with discharged batteries.

Please refer to paragraph  D-6-2 -Li-ion battery

Please refer to paragraph  D-7-2 -Optimise battery life

6.1 Hydraulic oil

External environmental conditions can reduce performance of the machine if the hydraulic oil temperature does not reach its optimum range.

It is recommended to use the hydraulic oil according to weather condition. Refer to the table below.

Environmental conditions	SAE Viscosity grade
Ambient temperature between - 15°C (5°F) and + 40°C (+ 104°F)	HV 32
Ambient temperature between - 35°C (- 31°F) and + 35°C (+ 95°F)	HV 32 Arctic

N.B.-:IT IS RECOMMENDED TO REPLACE LOW TEMPERATURE OIL AS THE AMBIENT TEMPERATURE REACHES + 15°C (59°F). IT IS NOT ADVISABLE TO MIX OILS OF DIFFERENT BRANDS OR TYPES.

D - Operation instructions

7 Battery care and maintenance

7.1 Battery recharge

7.1.1 On-board charger

The on-board charger is used to charge the semi-drive batteries. The charger's power is 3000W and the maximum intensity is 14A for 220V / 240V and 110V / 120V networks. Battery charging starts as soon as it is connected via the mains supply.

N.B.:-NO MOVEMENTS ARE ALLOWED DURING BATTERIES CHARGING CYCLE AND WHILE CONNECTED TO AN EXTERNAL POWER OUTLET.

Battery charger	69 V / 50 A or 60 A
Electric power supply	85 - 265 V AC / 50-60 Hz / 16 A
Battery voltage	48 V
Charging time	Between 10 h and 20 h

Locations

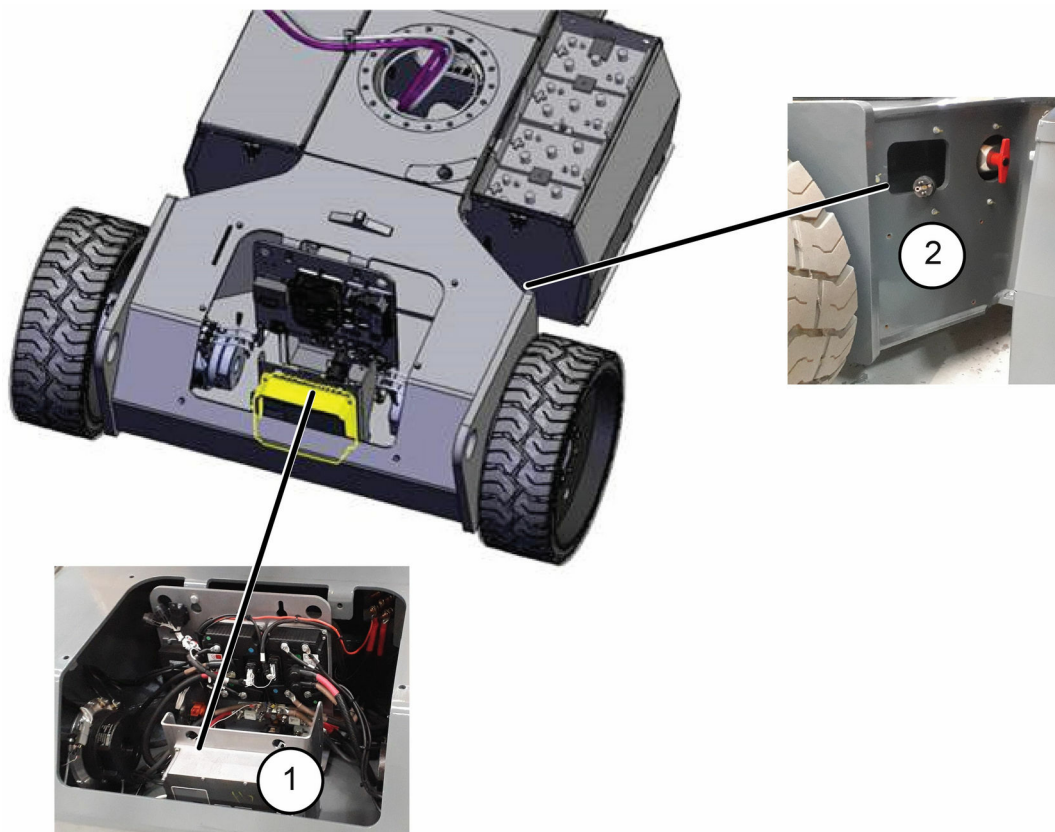

Marking	Description
1	On-board charger
2	Battery charger mains cable



Never replace the charging cable without written permission from HAULOTTE®.

D - Operation instructions

7.1.2 Battery charging



- Do not use an external charger or jump the batteries.
- Ensure that the mains power supply is adapted and equipped with circuit breakers ensuring it is safe:
 - If a "cable reel" type extension is used, the cable must be completely unwound before recharging.
 - The cable cross-section must be at least 2,5 mm² or more, depending on the length of the cable.
 - The socket must be able to deliver a current of 16 A.
 - If power of the supply is not great enough, a limited charge power can be selected from the (22) screen (Accessible with level 1 code) .

Machine settings/Machine configuration/Option setting/Battery charge configuration/

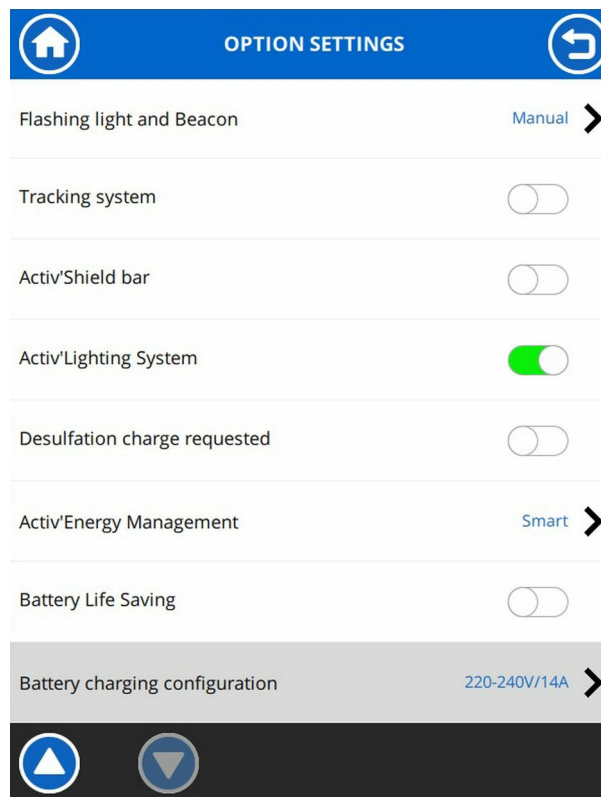

D - Operation instructions

Machine settings/Machine configuration/Option setting/Battery charge configuration/

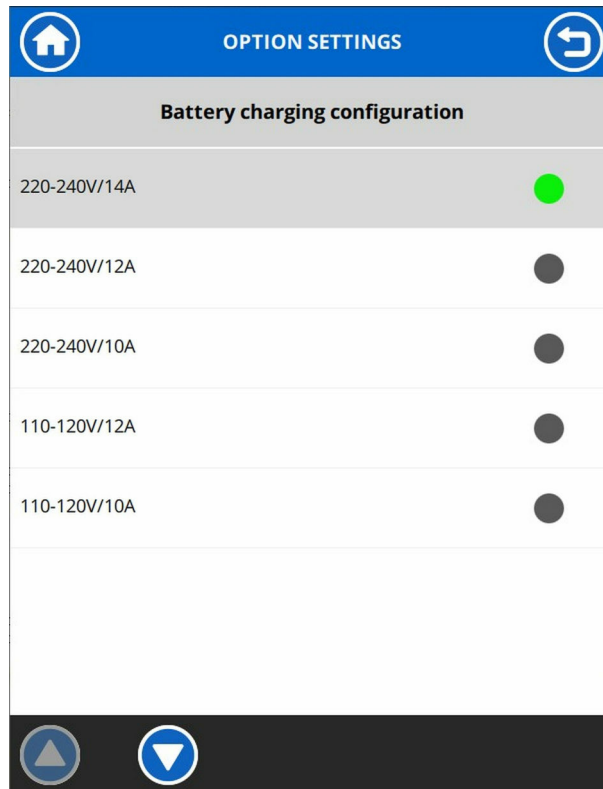

- Do not charge the battery when the outside temperature is -20°C .
- ALWAYS charge batteries in open, well-ventilated areas.
- You are advised to fully charge the battery at least 1 time every 7 days. If this is not done, a reminder will appear on the (22) screen of the ground control box.

Duration of charge cycle:

- 10 hours approximately, on 220 - 240 V AC / 14A network.
- 20 hours approximately, on 110 V AC / 12A network.

The charge cycle stops automatically when charging is complete.

It can take up to 24 hours for a full charge if the battery levels are very low (Charge status less than 5 %).

D - Operation instructions

Charge screen

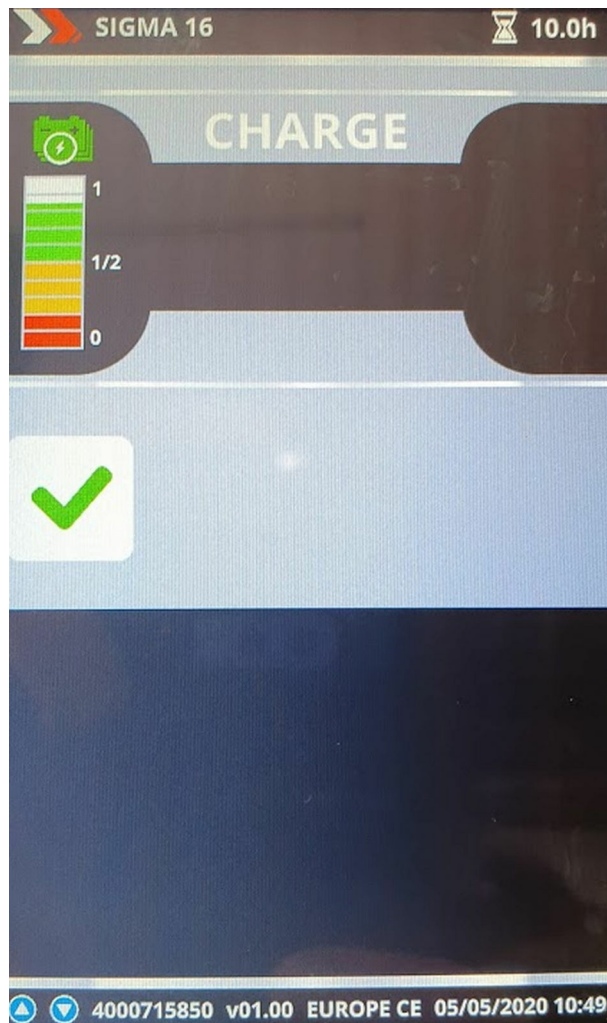

7.2 Battery care and maintenance

7.2.1 Filling batteries

The procedure described below only applies to open lead acid batteries. 6 V open lead-acid battery blocks are composed of 3 2 V single cells connected together in series. The cells are immersed in an electrolyte composed of 1/3 sulfuric acid and 2/3 deionized water.



The batteries must **ONLY** be filled after charging them fully. Failure to comply with these instructions may lead to the electrolyte overflowing, etc...



The batteries **MUST** be filled when necessary or the batteries may be irreparably damaged. The lead plates oxidize in the air. They must always be covered with electrolyte.



If the lead plates are no longer submerged, top up with de-ionized water and cover the plates to the top. Then charge the batteries completely and top up the level with de-ionized water if necessary..



The water level in the batteries cannot be topped up if the temperature is lower than 0° as the distilled or deionized water freezes in the centralized filling system.



For machines equipped with the traction battery option: Refilling the batteries is not permitted until they have reached 10 complete charging cycles..

D - Operation instructions

7.2.1.1 Procedure to fill the batteries manually-Option

Single-Point Watering System

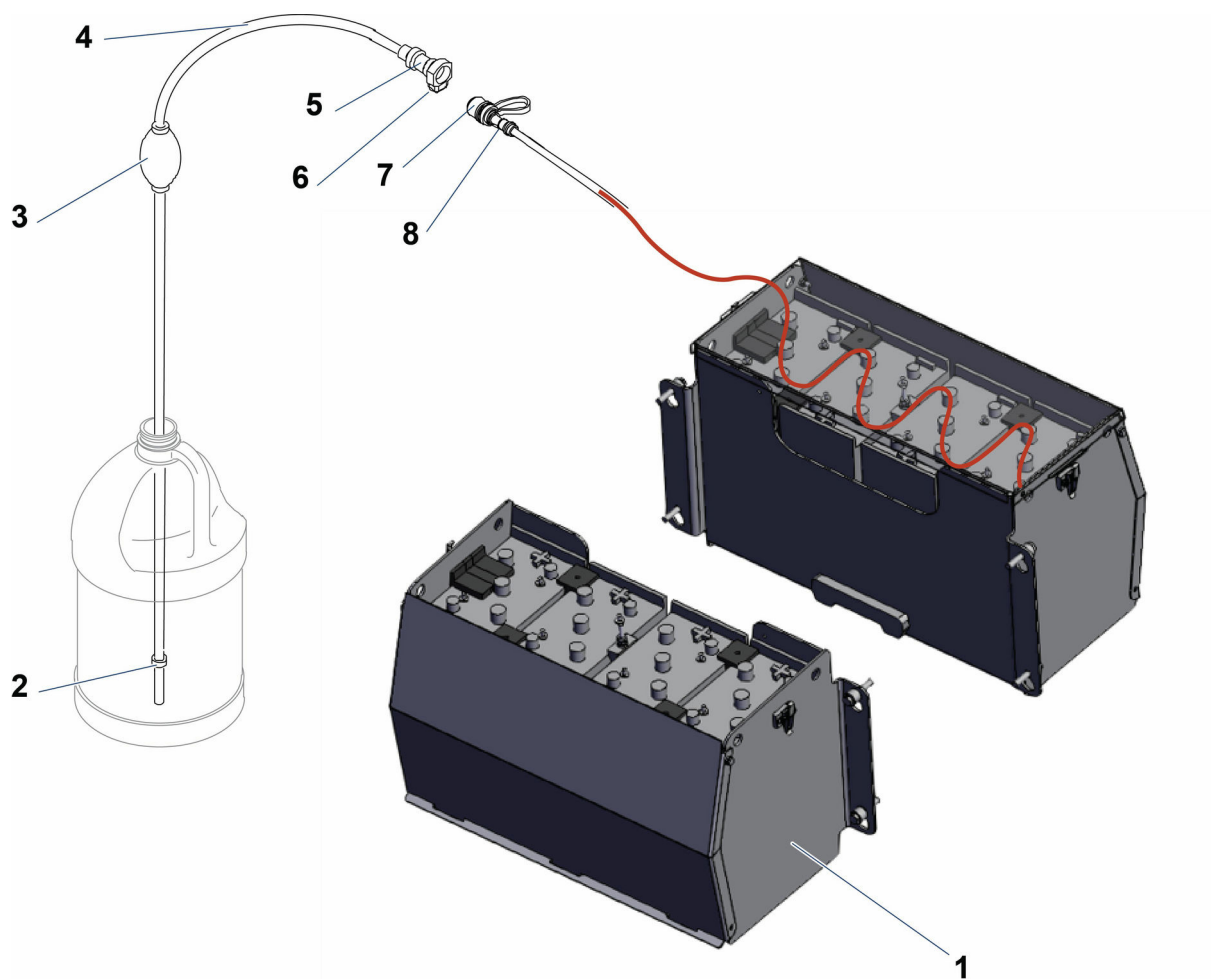

Marking	Description
1	Battery
2	Filtered intake
3	Hand pump
4	Hose
5	Female adapter
6	Push-button
7	Dust cover
8	Male adapter

Completely charge the batteries before connecting the distilled-water-filling unit.

Procedure:

1. Launch a full charge of the battery and check the charge indicator.

D - Operation instructions

2. Disconnect the batteries charger and put back the plug in its housing.



Levelling of the elements should always be done after charging the batteries. Watering a battery before charge (or with a low charge level) can lead to boil-over, resulting in potential bodily injury and potential damage to the watering system and the battery.

1. Unlock both locks.
2. Remove the covers.
3. Immerse the filtered inlet (2) of the transparent hose (4) fitted with a hand pump (3) in a demineralized water canister (Supplied with the machine) .
4. Press the hand pump (3) to prime it until the water rises in the hose (4)
5. Once the hand pump (3) is primed, remove the male connector (8) cap (7) from the black supply tube assembly
6. Connect the female connector (5) quick-hitch from the centralized filling system, including the hand-pump, to the male connector (8) .
7. Press firmly on the hand pump to bring the distilled water to the batteries (1) .
8. When the bulb (3) becomes resistant, this means that all the battery cells are filled appropriately.
9. Then uncouple the female connector (5) from the male connector (8) filling tube by pressing on the yellow button (6), then replace the cap (7) on the machine hose.
10. Close the machine covers.
11. Do not let the can to connect after filling is finished because this could cause the batteries to overflow.
12. Place the cover in the correct position on the batteries.
13. Unlock both locks on each side of the battery container.

7.2.1.2 Procedure to fill the batteries automatically-Option

1. Open the cap.
2. Fill the can with demineralized water.
3. Close the cap properly.
4. Fully recharge the batteries in order to restart automatic filling or activate automatic filling from the ground control box touchscreen.



D - Operation instructions

Navigation in the menus:



7.2.2 Desulfation charge

Normal battery use leads to sulfatation of the lead plates during discharge (Formation of lead sulfate) . Recharging the battery dissolves the lead sulfate. The plates are desulfated.

Moreover, sulfatation also appears if the battery self-discharges during storage in a low state-of-charge (< 70%).

As the battery ages, the lead sulfate may become harder and harder and increasingly difficult to eliminate by normal charging. This leads to a loss of autonomy. The desulfation charge is a way of regenerating the battery.



To improve the efficiency of the desulfation charge, you are advised to launch it for a battery discharged to a state-of-charge less than 30%.

Procedure:

- Go to the machine set-up menu->Option->Desulfation request (Code HAULOTTE DIAG level 2) ;
- The option is active and will be implemented during the next mains charge ;
- Charging time is increased up to 30 h ;

7.3 Optimise battery life

To optimize battery performance and life-time, you are advised to follow the recommendations below:

- Carry out regular battery maintenance as described.
- Do not store the machine discharged (Duration greater than 72 hours) .
- Carry out full charges regularly.
- Do not keep a machine in a state-of-charge less than 70% for no useful purpose.



- A full battery recharge is OBLIGATORY every 35 hours of use of the machine.
- After 45 hours of use without a full recharge, there is a risk of damaging the batteries.

Keep the top of the batteries clean and dry. Incorrect connection or corrosion may cause a high loss of power.

D - Operation instructions

	Full charge	Filling control	Desulfation charge
In use			
If state-of-charge < 50% at the end of a working day	X		
Every 35 hours of use	X		
Before placing in storage	X		
1 time a week	X	X	
1 time every 2 weeks		O	
1 time a month		O	
1 time every 6 months			X
In storage			
1 time a month	X		



In case of extended storage, you are advised to fully charge the battery then disconnect the power circuit  D 5.5 Storage. Charging the battery monthly is still recommended.



The battery's water consumption depends on its use. You are advised to check the water level 1 time a week.

E - General Specifications

1	Machine dimensions.....	3
2	Major component masses.....	5
3	Acoustics and vibrations.....	6
4	Wheel/Tire assembly.....	7
4.1	Technical specifications.....	7
4.2	Inspection and maintenance.....	8
5	Options.....	10
5.1	Compatibility.....	10
5.2	Advanced Access Management - Access control and usage restriction.....	10
5.3	Platform.....	22
5.4	Swing gate.....	23
5.5	Plumber's kit.....	24
5.6	Signalling cones holder.....	27
5.7	Neon tube holder.....	30
5.8	Activ' Shield Bar - Secondary crush risk reduction system (If fitted)	33

E - General Specifications

1 Machine dimensions

Stowed / Transport position: Configuration that takes the minimum floor space necessary for storage and / or delivery of the machine-Access position- SIGMA 16 - SIGMA 46 - SIGMA 16 PRO - SIGMA 46 PRO.

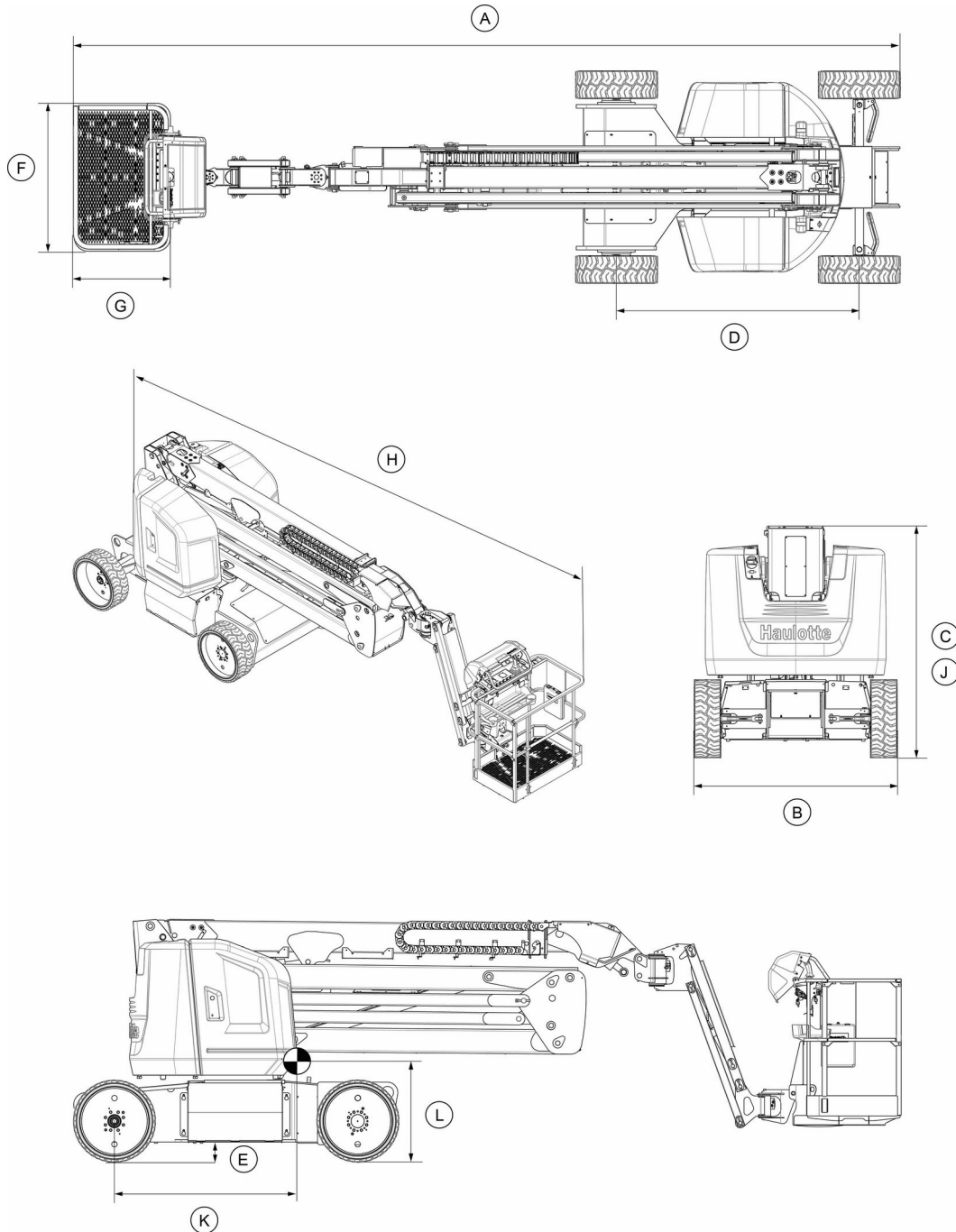

E - General Specifications

Machine		SIGMA 16 - SIGMA 46		SIGMA 16 PRO - SIGMA 46 PRO	
Marking	Specifications-Dimensions	SI	Imp.	SI	Imp.
A	Overall length of machine	6,60 m	21 ft 8 in	6,65 m	21 ft 10 in
B	Overall width of machine	1,75 m	5 ft 9 in	1,75 m	5 ft 9 in
C	Overall height of machine	2,00 m	6 ft 60 in	2,00 m	6 ft 60 in
D	Wheel base	2,00 m	6 ft 60 in	2,00 m	6 ft 60 in
E	Ground clearance	17 cm	7 in	17 cm	7 in
F X G	Platform dimensions	1,2 x 0,8 m	3 ft 11 in x 2 ft 7 in	1,2 x 0,8 m	3 ft 11 in x 2 ft 7 in
H	Storage length	6,60 m	21 ft 8 in	6,65 m	21 ft 10 in
J	Storage height	2,00 m	6 ft 60 in	2,00 m	6 ft 60 in
K	Center of gravity- X	1,13 m	3 ft 8 in	1,20 m	3 ft 11 in
L	Center of gravity- Y	0,95 m	3 ft 2 in	0,95 m	3 ft 2 in

E - General Specifications

2 Major component masses

N.B.:-MASSES MEASURED WITH EMPTY TANKS.

Component	SIGMA 16 - SIGMA 46	SIGMA16 PRO - SIGMA 46 PRO
Wheel mass	85 kg - 187 lbs	
Frame assembly mass	906 kg - 1,998 lbs	
Counterweight mass	2 700 kg - 5,954 lbs	
Turret assembly mass	589 kg - 1,299 lbs	
Engine compartment mass	168 kg - 370 lbs	
Arm assembly mass	753 kg - 1660 lbs	
Boom assembly mass	549 kg - 1,211 lbs	558 kg - 1,230 lbs
Jib assembly mass	113 kg - 249 lbs	148 kg - 326 lbs
Platform assembly mass	131 kg - 289 lbs	

E - General Specifications

3 Acoustics and vibrations

The acoustics and vibrations specifications are based upon the following conditions:

- The airborne noise emissions at workstation are determined per European Directive 2006/42/CE.
- The guaranteed sound power level LWA (displayed on the product) is determined per European Directive 2000/14/CE.
- The vibrations transmitted by the machinery to the hand/arm system and to the whole body are determined per European Directive 2006/42/CE.

Specifications	
Sound pressure level at workstation	68 dBA
Vibrations hand/arm	Vibration transmitted by this MEWP to the hand-arm does not exceed 2,5 m/s ² (98,4 in/s ²)
Vibrations whole body	Vibration transmitted by this MEWP to the whole body does not exceed 0,5 m/s ² (19,6 in/s ²)

E - General Specifications

4 Wheel/Tire assembly

4.1 Technical specifications

Component	Standard wheel	Variant wheels	Option wheel - SIGMA 16 - SIGMA 46 only	
Reference number	Camsco 675 x 230	Exmile 676 x 229	Exmile 676 x 229	
Type	Solid Tire		Rugged Tire	Solid Tire
Wheel mass	85.2 kg (+/- 2.6 kg) (188 lbs(+/- 6 lbs))	82.6 kg (+/- 12 kg) (182 lbs (+/- 26 lbs))	96 kg (+/- 8 kg) (212 lbs (+/- 18 lbs))	91.2 kg (+/- 8 kg) (201 lbs (+/- 18 lbs))
Size	675/230 mm (26 in / 9 in)	676/229 mm (26 in / 9 in)	676/229 mm (26 in / 9 in)	
Torque	170 Nm (125 lbs ft)			

E - General Specifications

4.2 Inspection and maintenance

Replace the wheels and the tires if any of the following conditions exist

- Presence of cracks, damage, deformation or other faults on the hub
- Damage to the tire:
 - Cut or hole > 3 cm (2 in) in the rubber side wall.
 - Blister or pronounced lump on the external and lateral wall.
 - Damaged wheel stud.
 - Damage or wear on the side wall to the extent that the reinforcing wire is visible.
 - Consistent wear of the ground contact surface greater than 25%

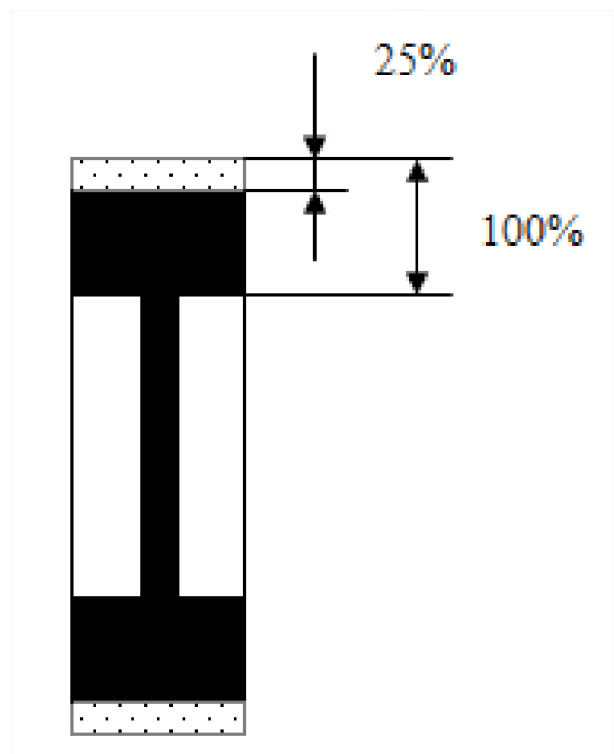
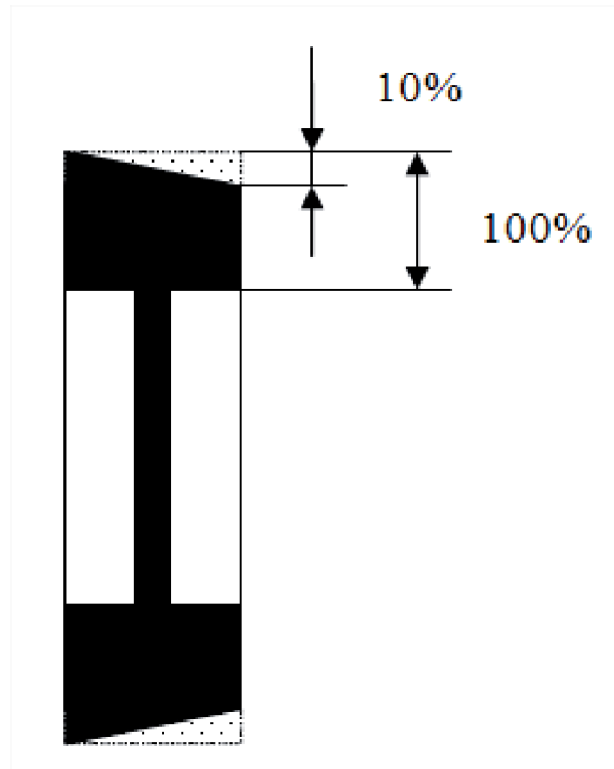

E - General Specifications



Tires and rims are critical components for the stability of the machine. For safety reasons

- Use only HAULOTTE® spare parts according to the technical characteristics of the machine. Refer to the spare parts catalog.
- Do not replace factory-installed tires with tires of different specifications or ply rating.
- Never replace solid tire with a pneumatic (air filled) tire.

Procedure of replacement:

- Raise the machine using a jack or a hoist.
- Loosen the wheel nuts on the wheel to be removed.
- Remove the wheel nuts.
- Remove the wheel.
- Install the new wheel.
- Tighten the wheel nuts to the recommended torque.
- Lower the machine to the ground.

N.B.-:IF A WHEEL HAS BEEN REPLACED, LOOK AT THE DIRECTION OF THE CLAMPS (WHICH INDICATES ROTATION IN THE AV DIRECTION) TO MAKE SURE IT IS CORRECTLY INSTALLED.

E - General Specifications

5 Options

5.1 Compatibility



Before installing any options or accessories, consult HAULOTTE® to check compatibility.

5.2 Advanced Access Management - Access control and usage restriction

5.2.1 Description

Access control and usage restriction are options available on a machine equipped with the SHERPAL solution. These options enable the use of the machine to be limited.

These limitations are set and managed from the MyHaulotte platform by the fleet manager.

5.2.1.1 Access control

The purpose of the access control is to prohibit lifting by an unauthorised operator. Access to the machine is via the RFID code and/or RFID board on the keyboard of the remote RFID reader.

Access control also allows the machine owner to block access to the machine's diagnostic screens for users without the level 3 code (Code available to authorised technicians only) . The level 3 code must be entered on the machine's screen.

5.2.1.2 Usage restriction

The usage restriction is a machine-related limitation. The usage restriction restricts the use of the machine when it is outside of the conditions of use predefined by the manager.

This function can be set from the MyHaulotte platform by those with the appropriate roles and rights.

The configurable conditions of use are as follows:

- GEOFENCE:-Authorisation for geolocalised use
- TIMEFENCE:-Authorisation for use according to defined time slots
- Remote restriction:-Forced activation of a usage restriction, regardless of the GEOFENCE and TIMEFENCE conditions
- Tracker fault:-Activation of the restriction if tracker in default

When the machine is outside of its conditions of use, only movements allowing micro-speed movement and folding are authorized.

When the machine is subject to a restriction, a message indicates this on the screen of the ground control panel. The user in the basket is notified by the indicator light on the control panel  which flashes at a frequency of 1s ON - 1s OFF.

5.2.1.3 GEOFENCE

The manager can activate the GEOFENCING restrictions in order to limit the machine's use inside a so-called AUTHORIZED geographical zone or outside a so-called PROHIBITED geographical zone, which he has defined. If the machine leaves this perimeter, its functionality will be restricted..

5.2.1.4 TIMEFENCE

The manager can activate the TIMEFENCING restrictions in order to restrict the usage during the defined period (Day, Time slot, ...) . If the machine is used outside of the time slot defined by the manager, its functionalities will be restricted.

A GEOFENCING and/or TIMEFENCING restriction becomes active after the machine is folded.

5.2.1.5 Remote restriction

It is also possible for the fleet manager to set a restriction remotely.

This is equivalent to the forced activation of a restriction, independent of the temporary TIMEFENCING or geolocalized GEOFENCING conditions of use.

E - General Specifications

5.2.2 Additional functions

5.2.2.1 Access control and usage restriction combination

The access control can be combined with the machine's usage restriction. If access control and usage restriction are active, the combination of the two applies so that the user is subject to the constraints of the strongest restriction.

5.2.2.2 tracker default function

This function allows you to force activation of the restriction in the event of a problem (e.g. tracker removed, unplugged or defective)..

This function is deactivated by default. This function can be activated on the Machine Sheet from the MyHaulotte platform.

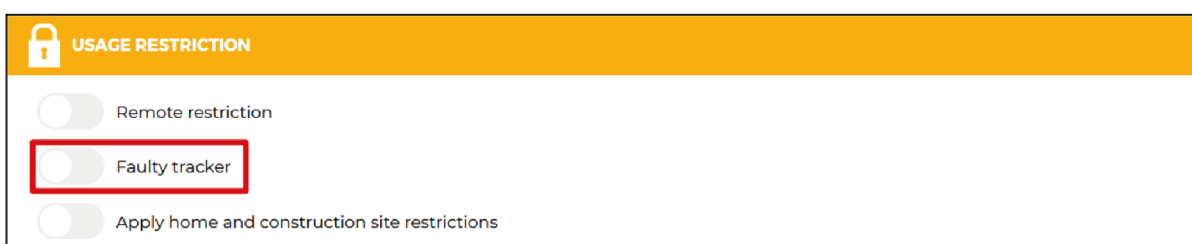
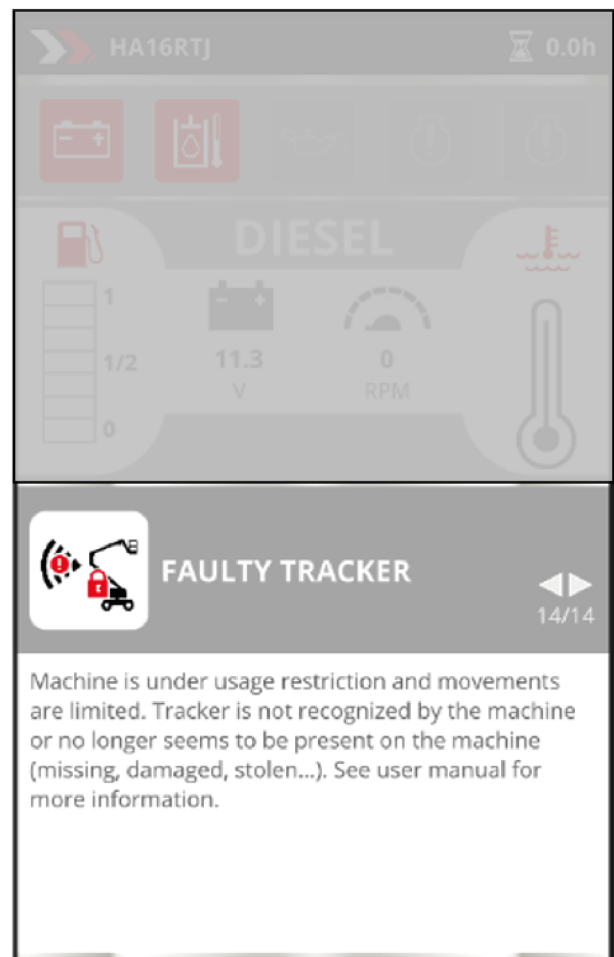

E - General Specifications

5.2.3 SUPER USER status

The fleet manager can add Super User status to a user from the MyHaulotte platform. The Super User profile enables the machine to be used, even if it is subject to a usage restriction.

The Super User profile can be connected to one or more machines.

The Super User profile can then start these machines using the PIN code generated by the fleet manager on MyHaulotte or using the RFID card assigned to him.

5.2.4 Code for removing restrictions

This code enables all restrictions to be permanently removed from a machine (Access control, usage restriction and remote restriction).

The code for removing restrictions is generated by the fleet manager on MyHaulotte. This code must then be entered on the machine's Restrictions Removal Code screen to unlock it permanently.

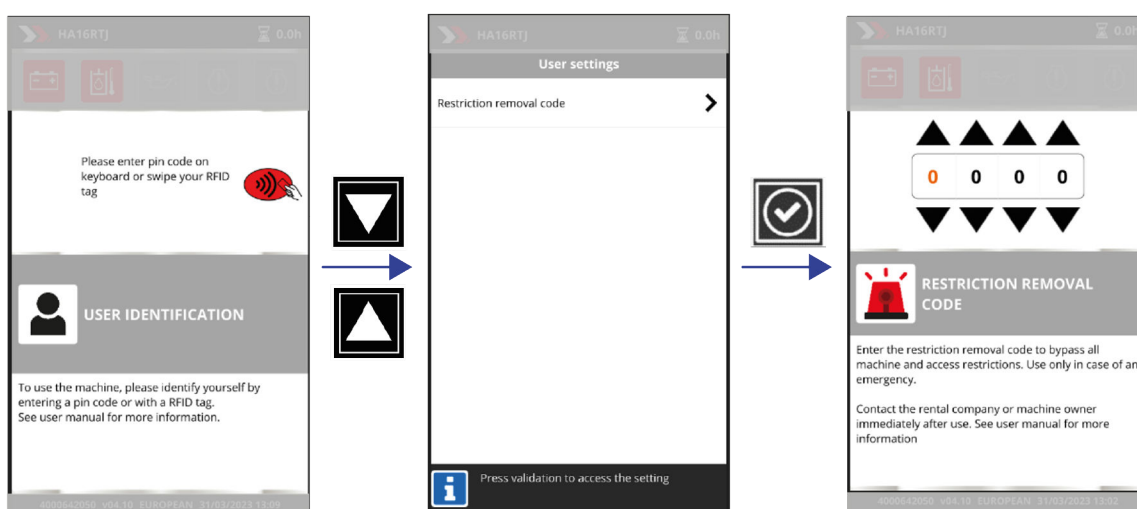

Enter the restriction removal code.



Permanently disable the restrictions and access control.

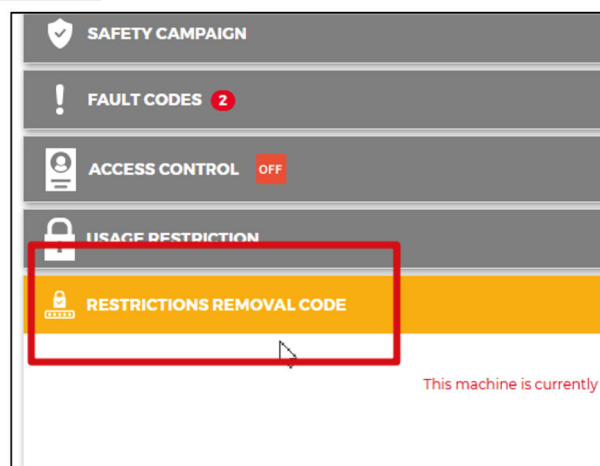

E - General Specifications

5.2.5 Operation

5.2.5.1 Using a machine with access control enabled

The following screen appears when starting up (energizing) the machine.

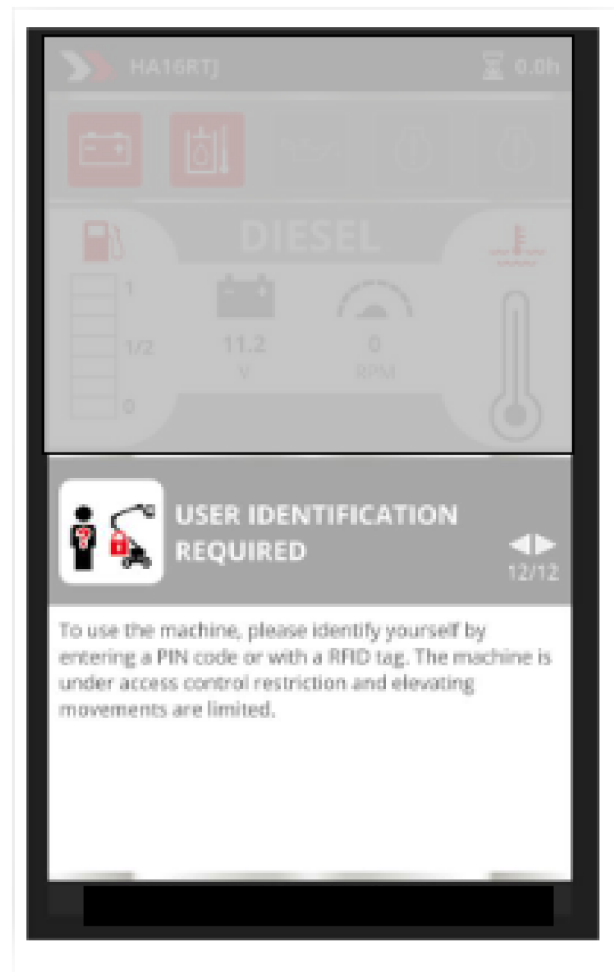

The machine can then be started by:

- A user with a User Identification start-up code. This code must be entered on the remote RFID keyboard.
- A Haulotte® technician with a Haulotte technician Identification. The level 3 code must be entered on the machine's screen.
- A user with a Restrictions Removal Code. This code is owned by the fleet manager or machine owner. The code is generated on the MyHaulotte platform and must be entered on the machine's screen. This code cannot be provided by Haulotte®.

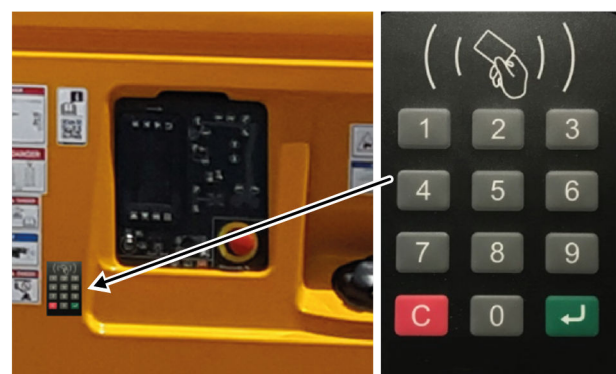



Start-up when access control is enabled:

- Enter the access code or use the RFID swipe card.
- Enter the Super User access code or use the Super User RFID swipe card.
- An authorized technician can use the level 3 code.
- Enter the restriction removal code on the machine's screen.

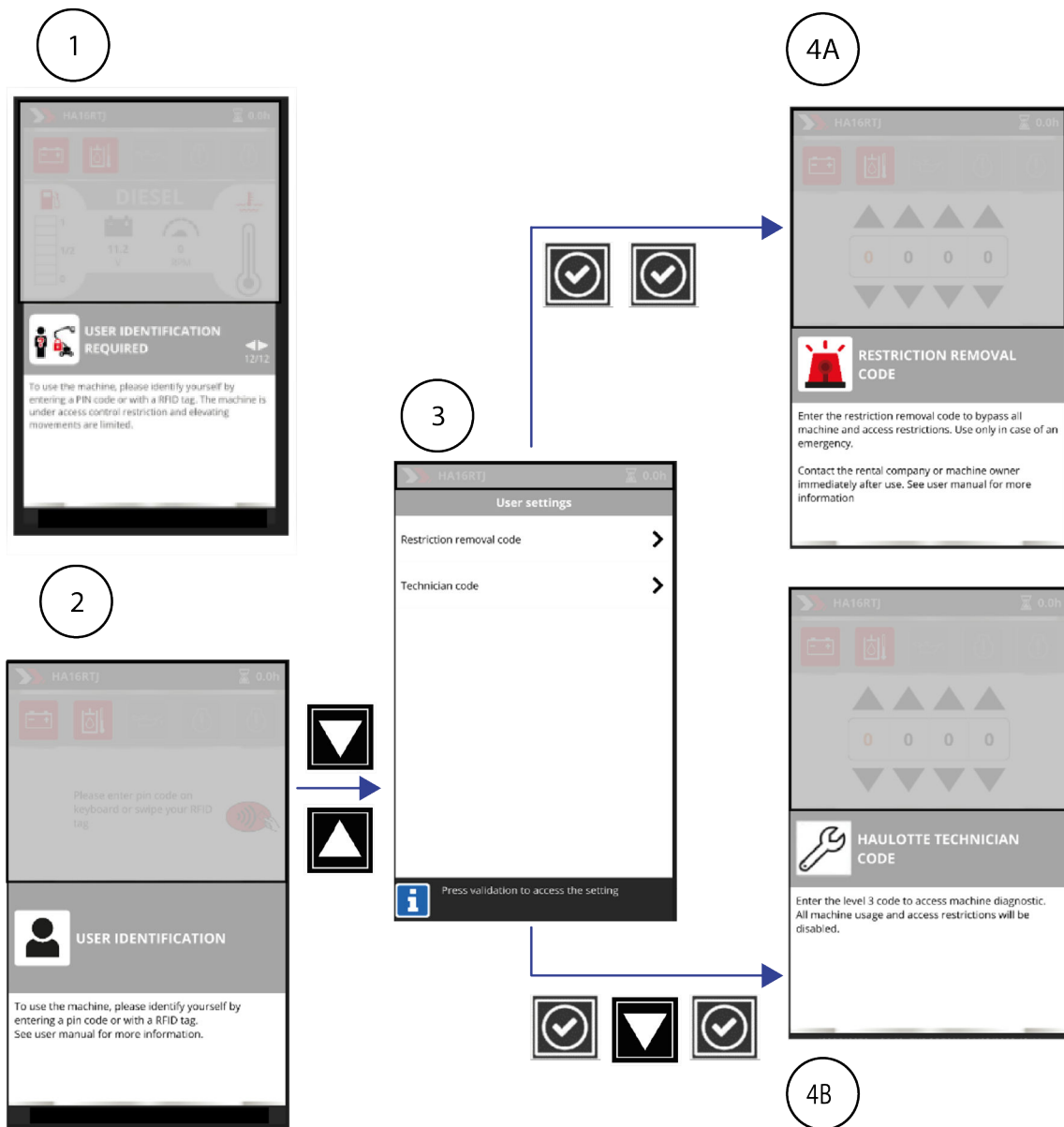
E - General Specifications



Marking	Actions
1	On the RFID keyboard, enter the PIN code or use an RFID card or enter the Super User code
2	/
3	/
4A	Enter the restriction removal code  Permanently disable the restrictions and access control. Return to normal operation.
4B	Enter the level 3 code  Temporary deactivation (until the machine is switched off) of the restrictions and access control.

E - General Specifications

5.2.5.2 Starting a machine with usage restriction enabled

Timefencing restriction activated and use within the time slot authorized

Conventional start-up without access code:

- The following screen indicates that a restriction is in place on the machine.

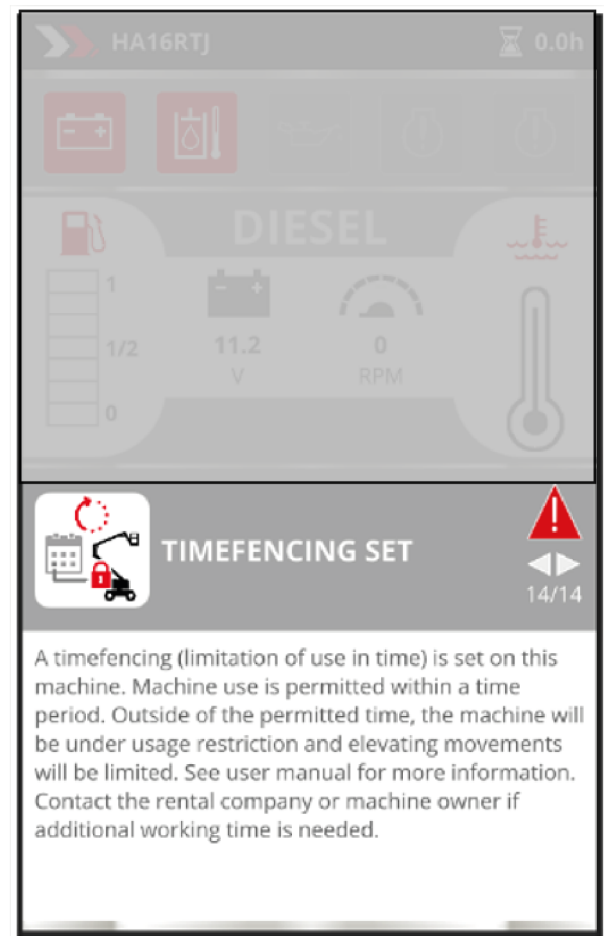



Timefencing restriction enabled and use outside range is permitted

Start-up when a TIMEFENCING usage restriction is programmed and enabled:

- A message on the screen indicates that a restriction is enabled.
- Enter a Super User access code or use the Super User RFID swipe card.
- An authorized technician can use the level 3 code.
- A user with a code can enter the restriction removal code on the machine's screen.

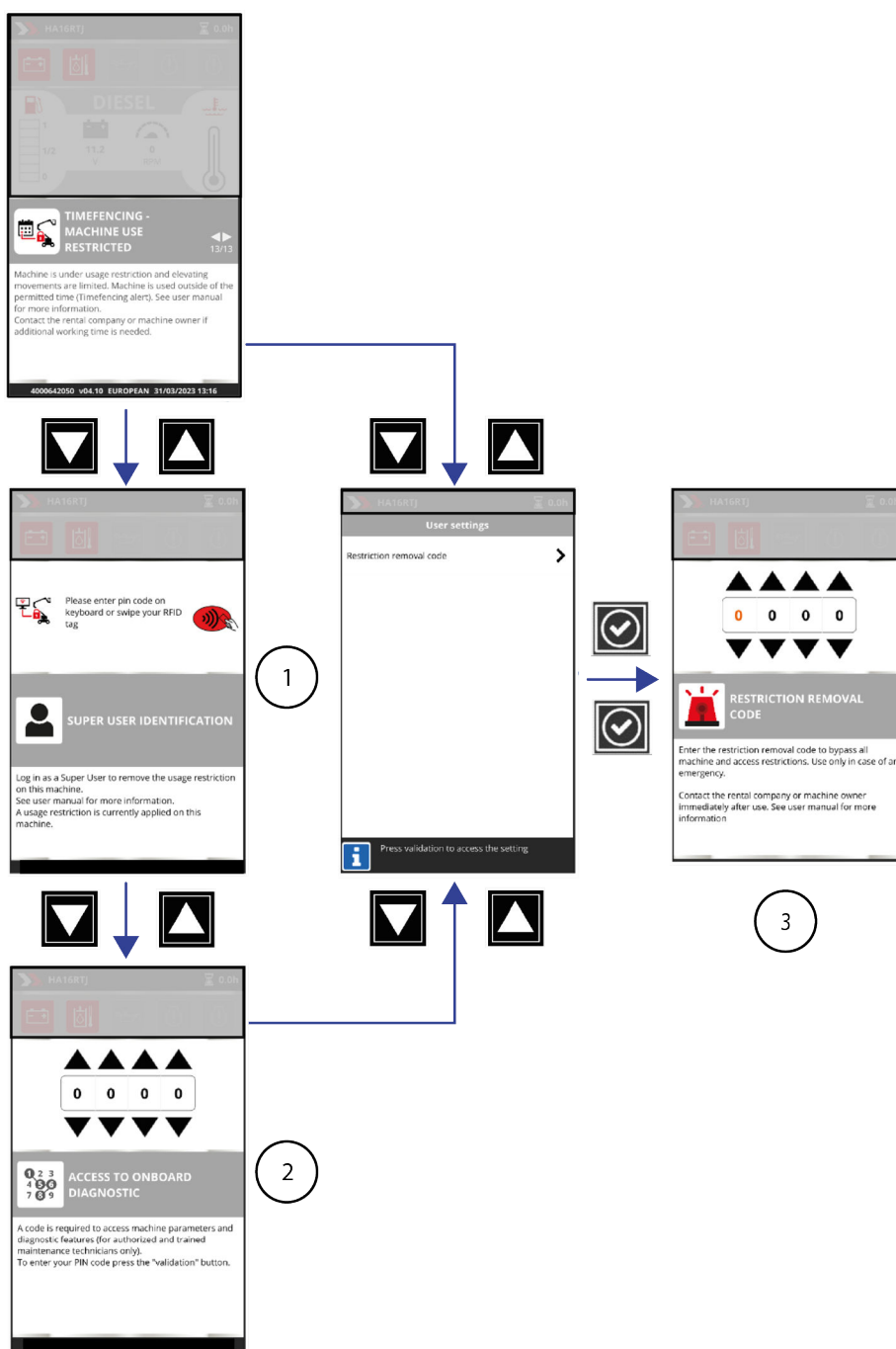
E - General Specifications



Marking	Actions
1	On the RFID keyboard, enter the PIN Super User code or use an RFID card or enter the Super User code
2	Enter the level 3 code  Temporary deactivation of restrictions and access control.
3	Enter the restriction removal code  Permanently disable the restrictions and access control. Return to normal operation.

E - General Specifications

Geofencing restriction enabled and used in an authorized geographical zone

Conventional start-up without access code:

- The following screen indicates that a restriction is in place on the machine.





Geofencing restriction enabled and used outside of the authorized geographical zone

Start-up when a GEOFENCING usage restriction is programmed and enabled:

- A message on the screen indicates that a restriction is enabled.
- Enter a Super User access code or use the Super User RFID swipe card.
- An authorized technician can use the level 3 code.
- Enter the restriction removal code on the machine's screen.

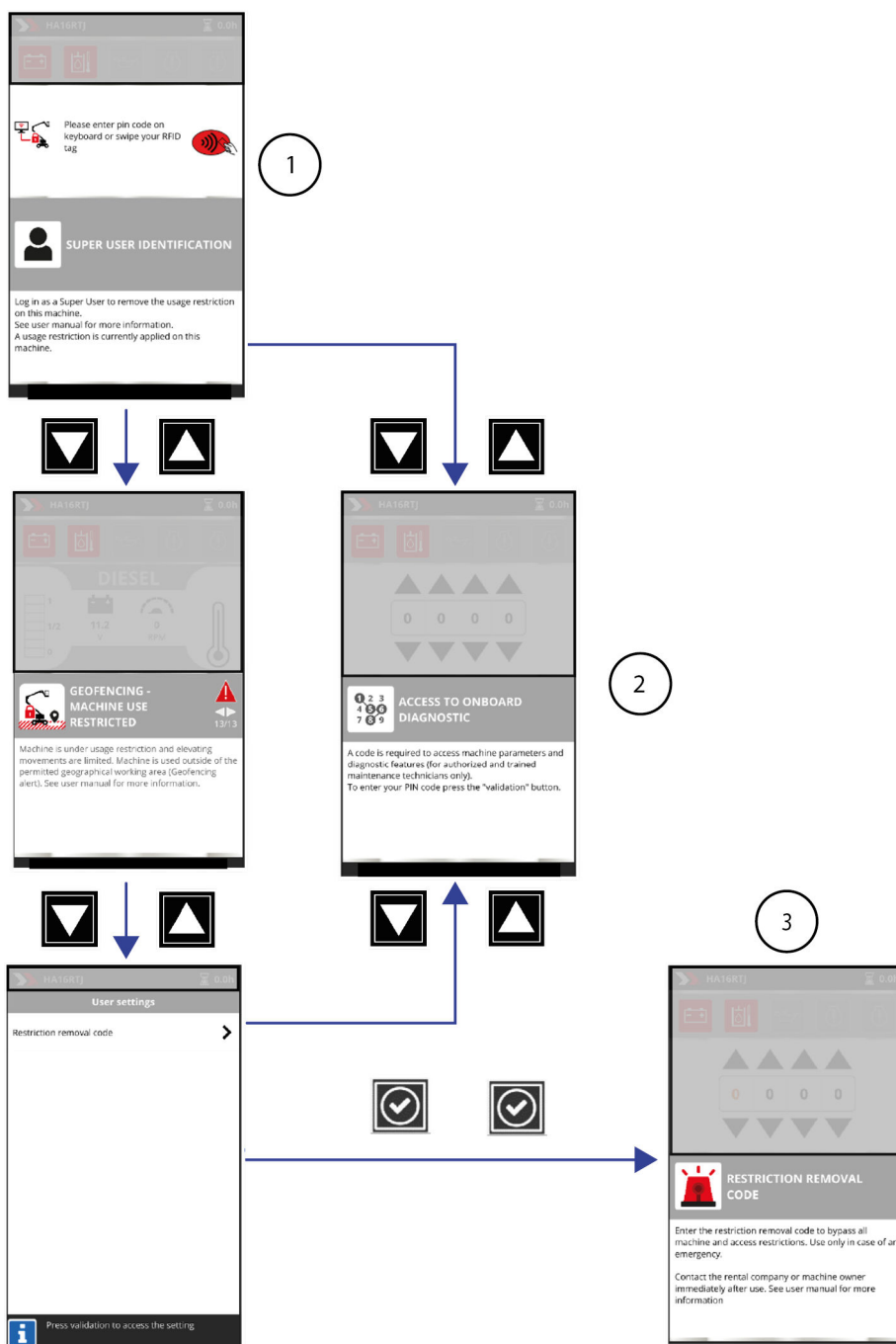
E - General Specifications



Marking	Actions
1	On the RFID keyboard, enter the PIN Super User code or use an RFID Super User card or enter the Super User code
2	Enter the level 3 code  Temporary deactivation of restrictions and access control.
3	Enter the restriction removal code  Permanently disable the restrictions and access control. Return to normal operation.

E - General Specifications



Remote restriction

Start-up when remote restriction is programmed and enabled:

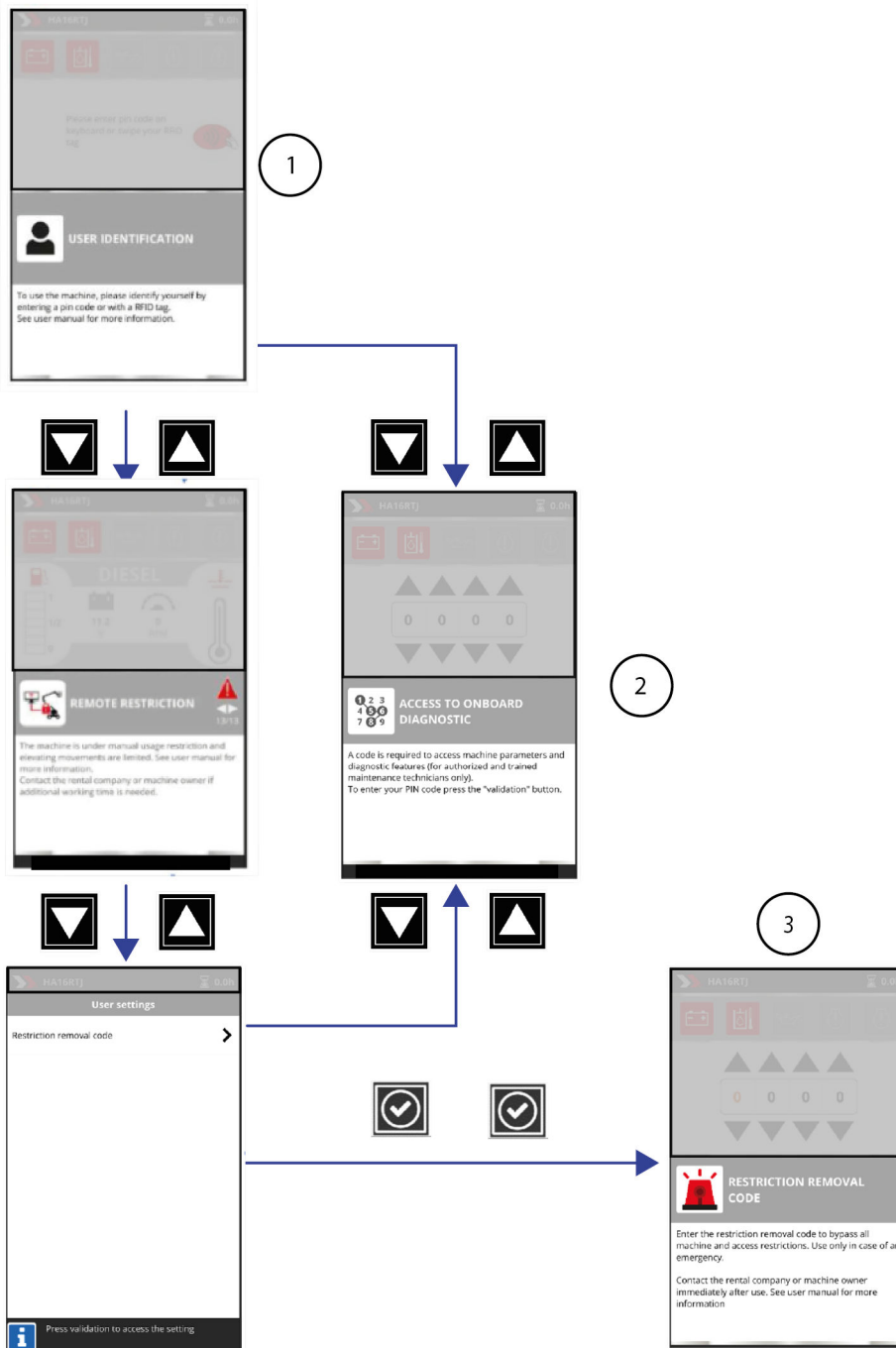
- A message on the screen indicates that a restriction is enabled.
- Enter a Super User access code or use the Super User RFID swipe card.
- An authorized technician can use the level 3 code.
- Enter the restriction removal code on the machine's screen.



E - General Specifications



Marking	Actions
1	On the RFID keyboard, enter the PIN Super User code or use an RFID Super User card or enter the Super User code
2	Enter the level 3 code  Temporary deactivation of restrictions and access control.
3	Enter the restriction removal code  Permanently disable the restrictions and access control. Return to normal operation.

Access control and usage restriction combination

- Enter the machine's access code or use the RFID swipe card (the machine remains under restricted use) or use the RFID Super User swipe card or use the Super User code.
- An authorized technician can use the level 3 code.
- Enter the restriction removal code on the machine's screen.

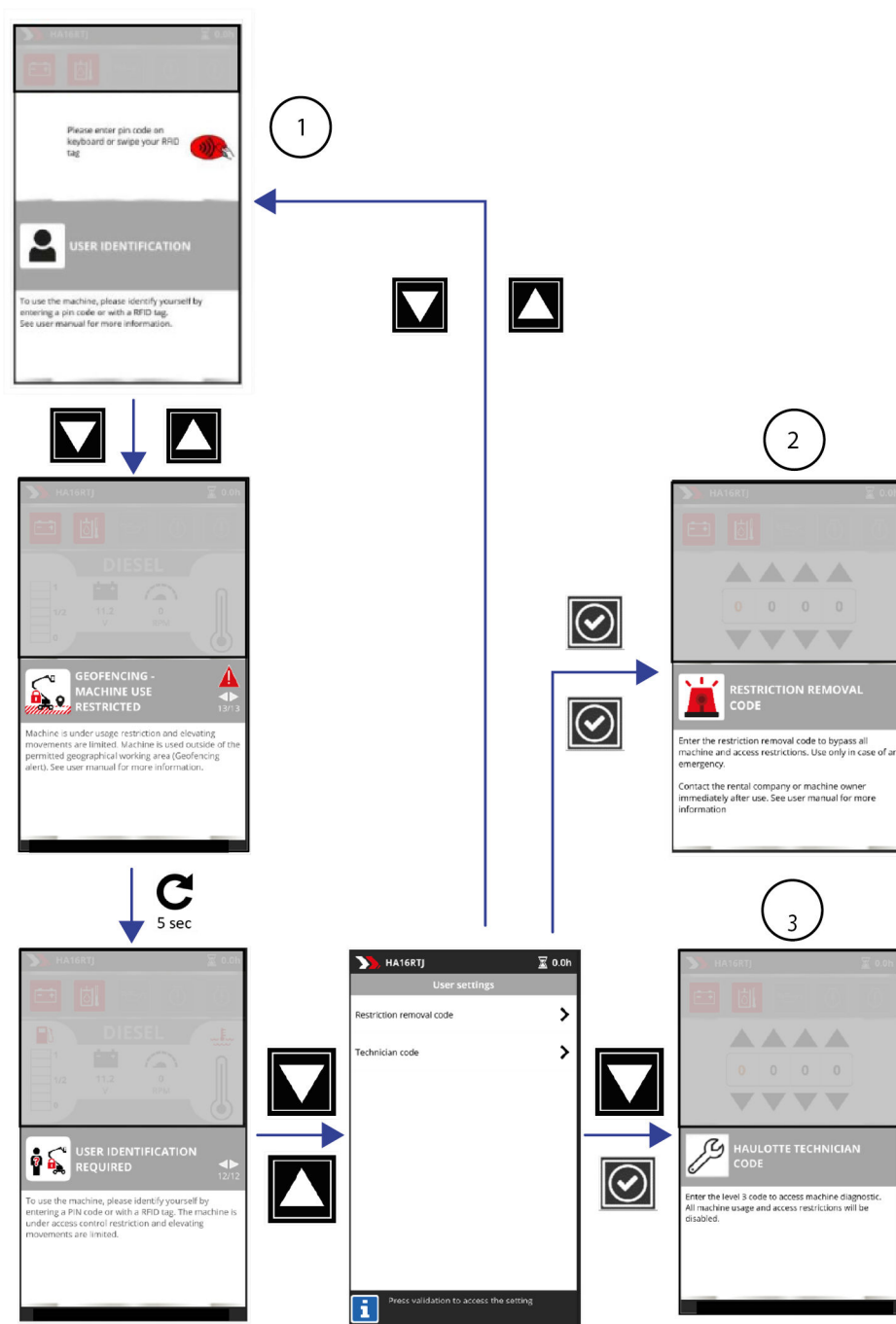
E - General Specifications



Marking	Actions
1	On the RFID keyboard, enter the PIN code or use an RFID card or enter the Super User code
2	Enter the restriction removal code  Permanently disable the restrictions and access control. Return to normal operation.
3	Enter the level 3 code  Temporary deactivation of restrictions and access control.

E - General Specifications

5.3 Platform

Technical specifications

Type	SIGMA 16 - SIGMA 16 PRO - SIGMA 46 - SIGMA 46 PRO		Platform entry
Small/standard platform	Platform length	1,2 m - 3 ft 11 in	Sliding bar (Standard)
	Platform width	0,8 m - 2 ft 7 in	
Large platform (Option)	Platform length	1,5 m - 4 ft 11 in	Sliding bar (Standard)
	Platform width	0,8 m - 2 ft 7 in	Swing gate (Option)

Swing gate



E - General Specifications

Sliding bar



5.4 Swing gate

5.4.1 Description

SWING GATE consists of a laterally mounted pivoting $\frac{1}{2}$ gate with closing latch, which enables a better access to platform. Spring loaded hinges and a latching mechanism allows the gate to swing inwards only.

Swing gate



5.4.2 Specifications

Width of the gate: 500 mm / 19.68 in.

E - General Specifications

5.4.3 Safety precautions



- The door forms part of the guardrail system and must be closed after entering the platform.



- Pay attention to the toeboard when entering or leaving the platform.

5.4.4 Pre-operation instructions

- Check that the locking mechanism is correctly fastened.
- Check the hinges and latch operate correctly and are not deformed.
- Ensure that the gate returns automatically to the closed and fastened position after entering or exiting the platform.

5.4.5 Specific decals, optional

Location of the decals

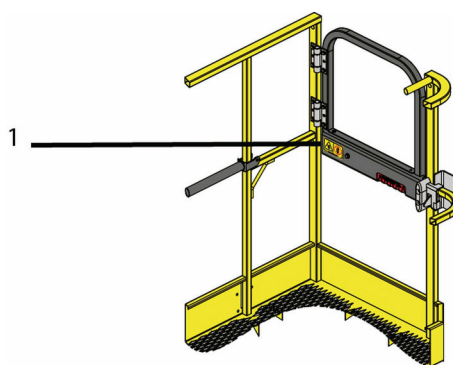

Marking	Description	Quantity	Part number
1	Hand crushing hazard	1	4001052080

5.5 Plumber's kit

5.5.1 Description

This attachment is an assembly designed to transport pipes and tubes. The assembly comprises of 2 cradles securely attached to the platform. The load (material) should be placed in both the cradles and secured with a strap (not supplied).

5.5.2 Characteristics

Type	SIGMA 16 - SIGMA 16 PRO - SIGMA 46 - SIGMA 46 PRO		Platform entry	Plumber's kit
Small/standard platform	Platform length	1,2 m - 3 ft 11 in	Sliding bar (Standard)	
	Platform width	0,8 m - 2 ft 7 in		
Large platform (Option)	Platform length	1,5 m - 4 ft 11 in	Sliding bar (Standard)	
	Platform width	0,8 m - 2 ft 7 in	Swing gate (Option)	

E - General Specifications

Component	Characteristics
Weight of the carrier	8 kg (20 lbs)
Weight of the equipment on the carrier	60 kg (132 lbs)
Maximum load surface	0,3 m ² (Ø 0,06 m x 1,5 m / 0,06 m x 1,2 m) / 3.23 sq.ft (Ø 0.19 ft x 4 ft 11 in / Ø 0.19 ft x 3 ft 9 in)
Maximum wind speed allowed	12,5 m/s - 45 km/h - 28 mph

5.5.3 Safety precautions



- Please read and assimilate the instructions before using the attachment.
- This accessory is designed to transport pipes and tubes. Do not use this attachment for transporting other types of load. .
- Do not suspend loads.
- Do not overload the attachment and ensure that the equipment is correctly attached by means of a strap (not supplied).
- Do not exceed the maximum allowable platform capacity. The combined weight of the attachment, load, the occupants, the tools and any other equipment must not exceed the maximum allowable platform capacity.
- Do not load tubes whose surface area exceeds the maximum authorized surface area. Exposing an additional surface area to the wind reduces machine stability. Do not install any other attachments that increase the surface area exposed to the wind.
- Do not use the machine if the wind speed exceeds the authorized limit of the attachment.
- The cradles should always be positioned such that they are within the platform. Position the bottom end of the cradles such that they are resting on the platform floor.
- Ensure that the tube does not extend beyond the dimensions of the platform.

5.5.4 Pre-operation inspection



- Check that the cradle has no cracks or other damage.
- Check that the cradle is correctly installed and secured to the platform.
- Check that the information decal is present on the cradle and is legible.
- Check that the strap is not twisted or torn.
- Check that the position of the load and attachment is not obstructing access to the platform or the controls.
- Check that the position of the attachment and the load is not reducing visibility during maneuvers in the work environment.

5.5.5 Operation

- Position the load to rest on the 2 cradles.
- Center the load on the cradles.
- Securely attach the load to each cradle with strap of adequate strength and dimensions.

E - General Specifications

Strapping example(s)

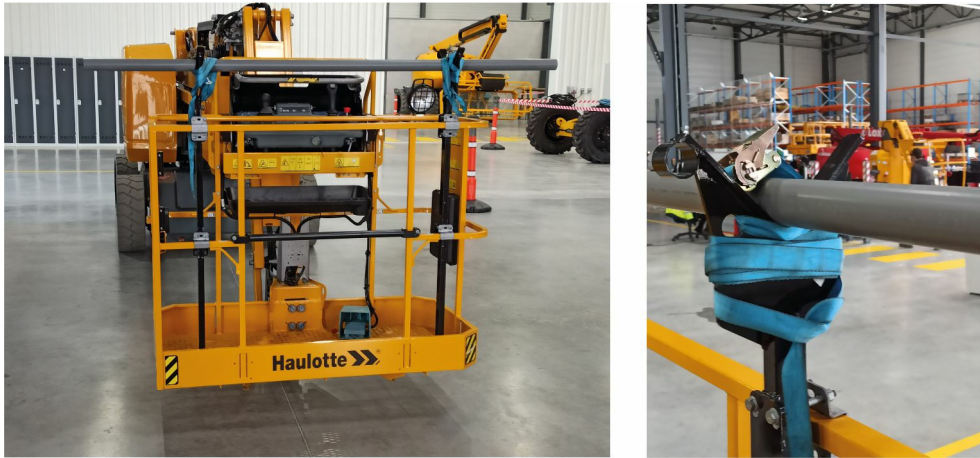

5.5.6 Assembly-Dis-assembly

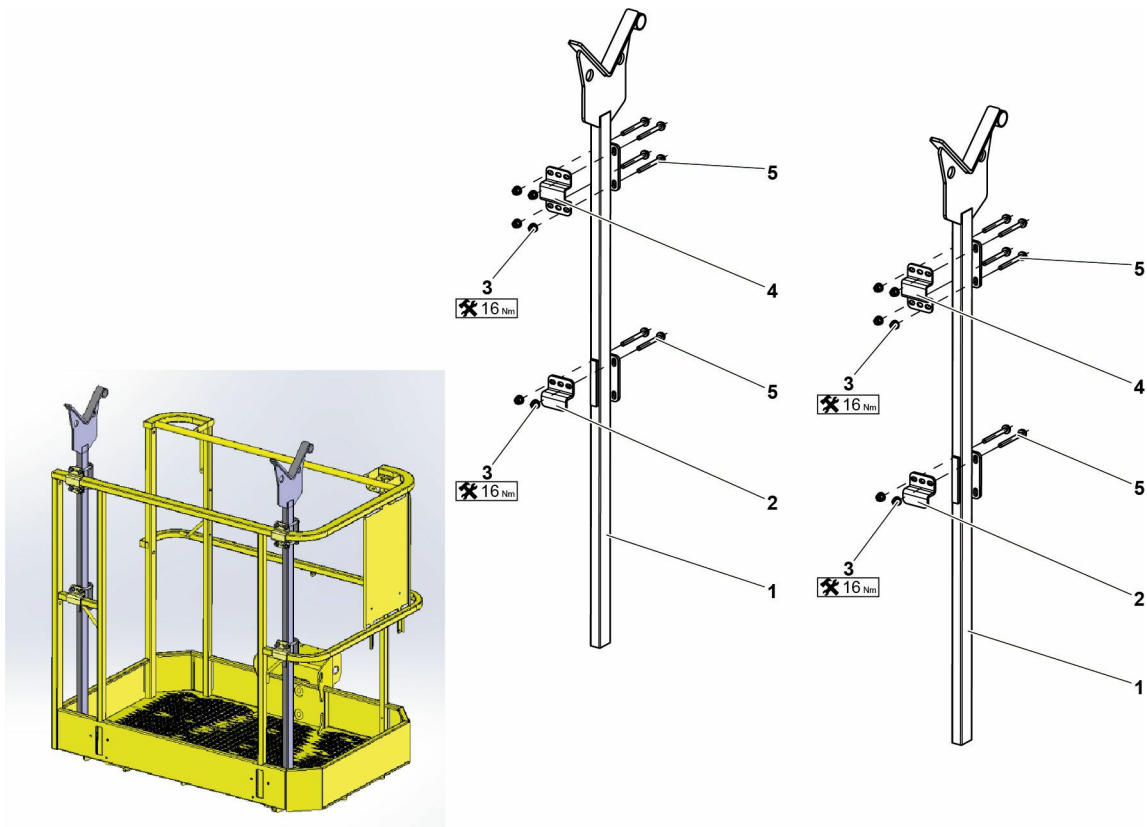

Marking	Description
1	Cradle
2	Flange
3	Nuts
4	Flange
5	Fastening screw

E - General Specifications

- Locate the cradles such that the load will be parallel to the length of the platform.
- Install cradles (1) to the guard rail using 4 supplied flanges (2) (4).
- Tighten up the flange using 4 supplied screw (5) and 4 nuts (3), wherever a cradle and the horizontal guard rail tubes intersect.

N.B.-:TORQUE REQUIREMENTS: 16 NM (11.8 FT LBS)

- Ensure that the bottom of cradle is resting on the platform floor.
- Ensure that the distance between the 2 cradles support and center the load.
- Pre-operation test: Place and secure the load of 60 kg (132 lbs) on the cradles. Ensure that the cradles can support the load and that there is no visual structural damage.

5.5.7 Specific decals, optional

Location of the decals

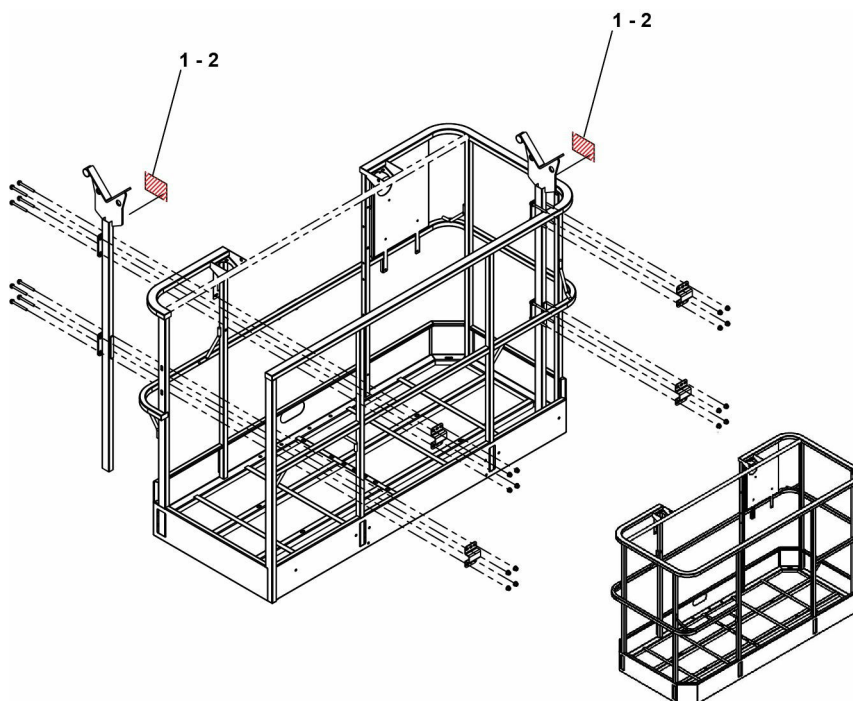

Marking	Description	Quantity	Part number
1	Risk of overturning	2	ANSI and CSA standards: In english4000131600 In french4000131610 In spanish4000131620 In german4000708570
2	Limit use of the option	2	CE, UKCA, AS and EAC standards: 4001098410

5.6 Signalling cones holder

5.6.1 Description

This accessory is a set designed for hanging signalling cones.

E - General Specifications

5.6.2 Characteristics

Component	Characteristics
Weight of the carrier	1,5 kg (3 lbs)
Weight of the equipment on the carrier	12 kg (26 lbs)

5.6.3 Safety precautions



- Please read and assimilate the instructions before using the attachment.
- Do not use this attachment for installing any other type of welder unit. This accessory is designed for hanging signalling cones.
- Do not overload the carrier (12 kg(26 lb) maximum).

5.6.4 Pre-operation inspection



- Check that the cradle has no cracks or other damage.
- Check that the support is correctly secured.

5.6.5 Operation

- Lower the holder.
- Place the cones in the holder.



E - General Specifications

Raised position



Position with traffic cones



E - General Specifications

5.6.6 Assembly-Dis-assembly

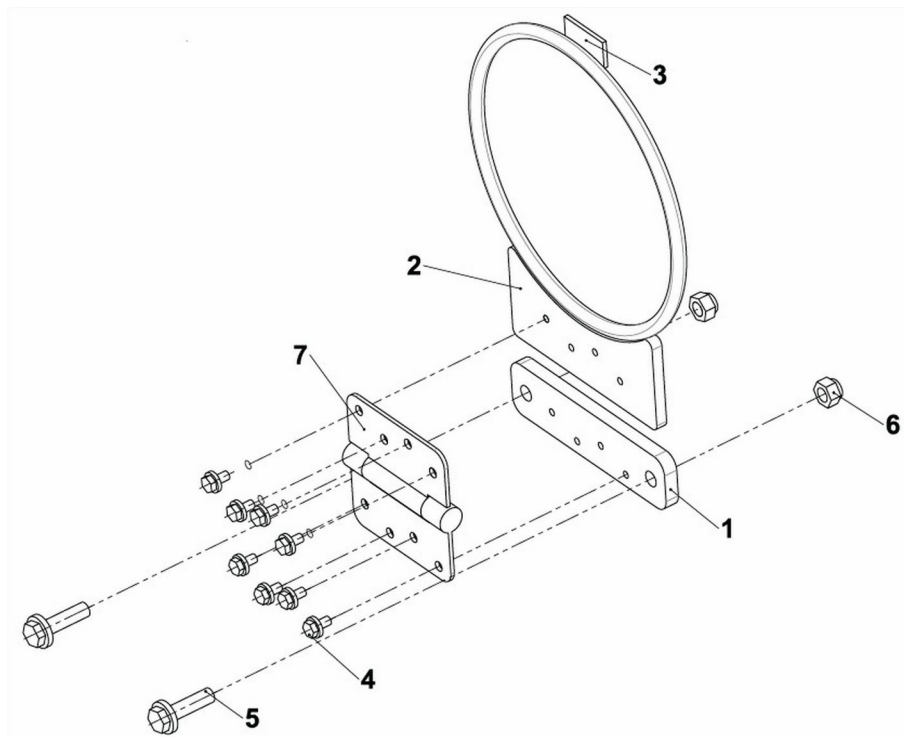

Marking	Description
1	Support plate
2	Carrier
3	Flat seal
4	Fastening screw (Tightening torques: 10 Nm (7,37 ft lbs))
5	Fastening screw (Tightening torques: 44 N.m (32,45 ft lbs))
6	Nut
7	Hinge

N.B.:-TORQUE REQUIREMENTS: 10 NM (7,37 FT LBS) (4) - 44 N.M (32,45 FT LBS) (5)

5.7 Neon tube holder

5.7.1 Description

This accessory is an assembly designed to store and transport neon lights safely.

E - General Specifications

5.7.2 Characteristics

Component	Characteristics
External height	1,28 m (4 ft 2 in)
External width	0,21 m (9 in)
External length	0,19 m (8 in)
Weight of the carrier	0,8 kg (2 lbs)
Weight of the equipment on the carrier	4,1 kg (9 lbs)

5.7.3 Safety precautions



- Please read and assimilate the instructions before using the attachment.
- Do not use this attachment for transporting other types of load. This accessory is designed for the safe handling of neon lights.
- Do not overload the carrier:
 - Capacity: maximum 47 tubes Ø 26 mm or maximum 125 tubes Ø 16 mm. Length 1200 mm.
- The carrier should always be positioned so that it is within the platform.

5.7.4 Pre-operation inspection



- Check that the cradle has no cracks or other damage.
- Check that the cradle is correctly installed and secured to the platform.
- Check that the strap is not twisted or torn.

5.7.5 Operation

- Strap the bracket to the tube holder.
- Position the bracket on the guardrail.
- Attach the bracket.



E - General Specifications

5.7.6 Assembly-Dis-assembly

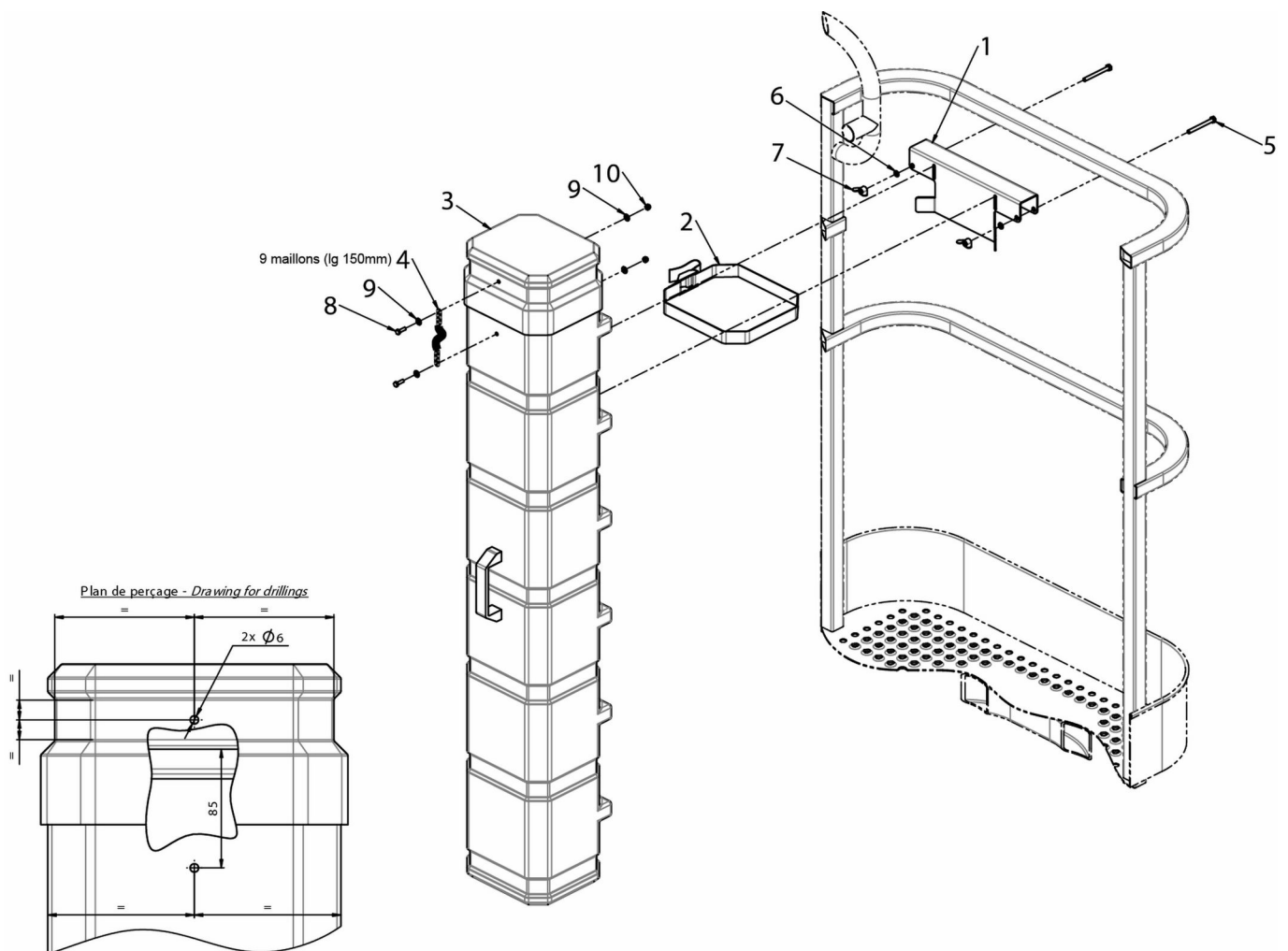

Marking	Description
1	Carrier
2	Strap
3	Neon tube holder (Length 1200 mm)
4	Chain (9 links - Length 150 mm)
5	Fastening screw
6	Washer
7	Nut
8	Fastening screw
9	Washer
10	Nut

E - General Specifications

5.8 Activ' Shield Bar - Secondary crush risk reduction system (If fitted)

5.8.1 Description



General Specification Activ' Shield Bar:

- The Activ' Shield Bar system is a device designed to reduce the risk of crushing against the control console when the machine moves, and to notify ground personnel if it is triggered.
- If the Activ' Shield Bar is triggered, all movements are stopped, the horn will sound and the blue light will activate.
- From the platform control console, only movements allowing the user to be freed are possible.
- System status:
 - The green indicator light on the Activ' Shield Bar system is off when the system is inactive or disabled.
 - The green indicator light on the Activ' Shield Bar system flashes when the system is active (machine not moving).
 - The green indicator light on the Activ' Shield Bar system is on when the system is active (machine moving).



- The system does not protect against external collisions when the machine is not moving.
- The system does not reduce the risk of crushing when the speed of movements is excessive and/or not adapted to the environment.



This system does not relieve the operator from the responsibilities of learning and practicing the principles of safe use and operation of the machine as provided by the user manual, employer's safety rules and worksite regulations.

5.8.2 Characteristics

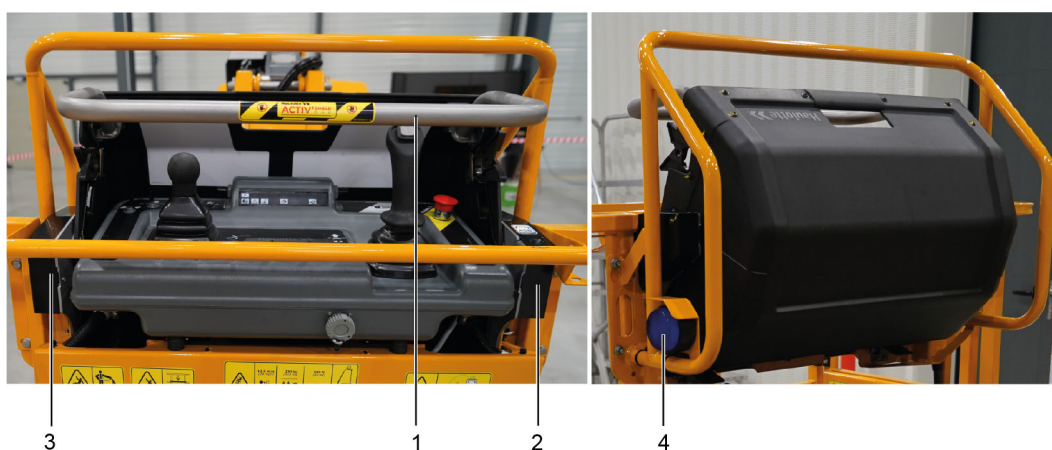

Marking	Description
1	Activation bar
2	Green indicator light
3	Sensor
4	Flashing light

E - General Specifications

5.8.3 Safety precautions



It is mandatory to ensure that the Activ' Shield Bar is functional at each start-up of the machine



Do not use the Activ' Shield Bar as a handhold. This could result in an inadvertent triggering of the Activ' Shield Bar.

- Check the work area for overhead clearances, obstructions or other possible hazards.
- When driving, position the platform so as to provide the best visibility possible and avoid any blind spots.
- Always ensure that the wheels are never driven any closer than 1 m from holes, bumps, tilts, obstructions, debris and ground coverings that may hide dangers.
- During operation, keep all the parts of the body inside the platform.
- To position the machine close to obstacles, you are advised to use the movements of the boom (arm, boom, etc.) instead of the drive movements.
- Do not drive fast in narrow or cluttered areas. Keep speed under control while making turns or sharp bends.

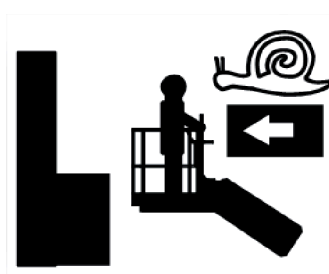
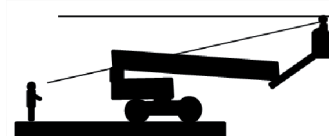

5.8.4 Pre-operation inspection



- If any item on the checklist is marked NO during the inspection; machine must be tagged and locked out and placed out of service.
- DO NOT operate the machine until all identified items are corrected and it has been declared safe for operation.

You will need: All machine functional tests to result positive.

E - General Specifications

Description	Yes	No
To ensure Activ' Shield Bar device is functioning correctly, perform the following:		
Select the upper console.		
Press the activation pedal and check that the green indicator light (2) flashes (machine not moving).		
Perform a movement and check that the green indicator light (2) is on.		
Simultaneously make a movement and push forward the activation bar to trigger the system: <ul style="list-style-type: none"> - Check that all movements are interrupted. - Check that the horn and blue indicator light (4) are working. 		

N.B.-:TO RESET THE ACTIV' SHIELD BAR SYSTEM, RELEASE THE ACTIVATION BAR, THE ACTIVATION PEDAL, THE CONTROLS, AND PRESS THE ACTIVATION PEDAL.

5.8.5 Operation

The Activ' Shield Bar system is triggered by pushing the activation bar. All movements are interrupted, the horn sounds and the blue indicator light comes on. Only movements allowing the user to be freed are possible (all necessary precautions must be taken during these operations to prevent any collision with or entrapment against the structures).

For safety procedures, refer to  D 4 Rescue and Emergency Procedures.

To reset the Activ' Shield Bar system, release the activation bar, the activation pedal, the controls, and press the activation pedal.

5.8.6 Specific decals

Location of the decals

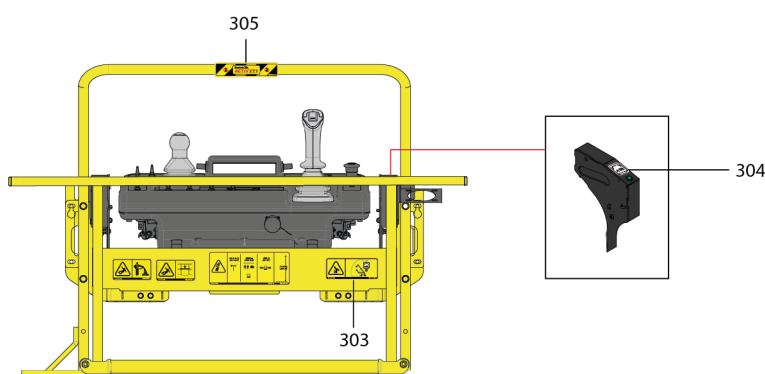

Marking	Description	Quantity	Part number - CE, UKCA, AS and EAC standards	Part number - ANSI and CSA standards
303	Activ' Shield Bar controls	1	4001364700	4001364690
304	Activ' Shield Bar controls	1	4001069620	4000596720
305	Do not lean on the bar	1	4001069640	4000206690

E - General Specifications

Activ' Shield Bar instructions - CE, UKCA, AS and EAC standards

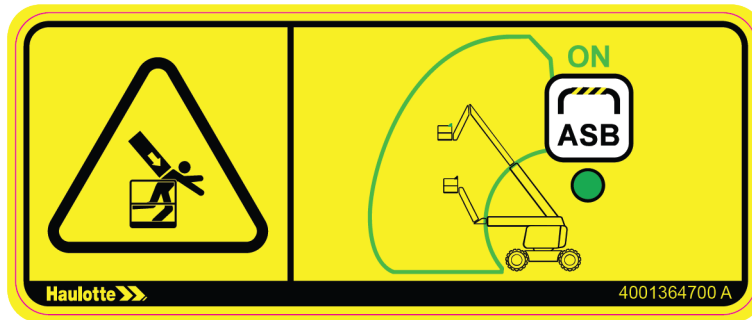

Activ' Shield Bar instructions - ANSI and CSA standards

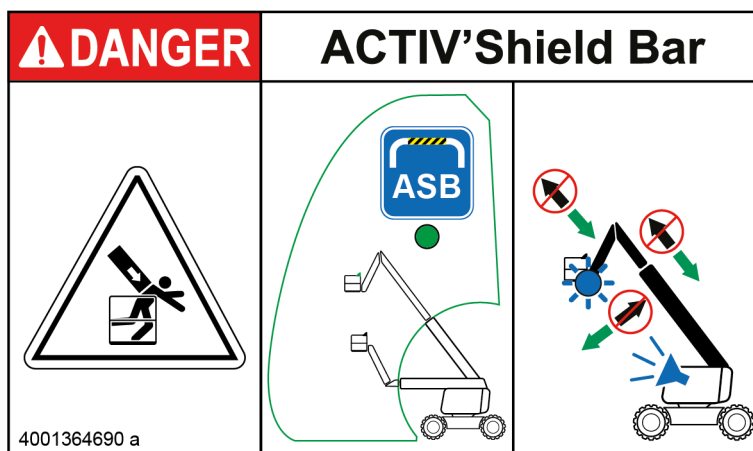

F - Maintenance

1	General.....	3
2	Maintenance Schedule.....	4
3	Inspection program.....	5
3.1	General program.....	5
3.2	Daily inspection.....	5
3.3	Periodic inspection.....	5
3.4	Reinforced inspection.....	6
3.5	Major inspection.....	6
4	Repairs and adjustments.....	7

F - Maintenance

1 General

As an owner and/or operator of Haulotte equipment, your Safety is of utmost importance to HAULOTTE® , which is why HAULOTTE® places such a high priority on product safety.

INSPECTIONS are not only required by HAULOTTE®, but may also be required by industry standards and/or local regulations.

To ensure your equipment continues to achieve the level of performance set in the factory, it is important to maintain it regularly. We remind you that it is strictly forbidden to make any modifications. Regular and timely inspections will reduce equipment down time as well as prevent possible injury.

N.B.-:DO NOT OPERATE UNLESS YOU ARE FAMILIAR AND TRAINED IN THE PRINCIPLES OF SAFE MACHINE OPERATION.

Overview:

- A walk-around inspection of the machine takes only a few minutes at the beginning and end of each shift
- The best way to prevent issues.

What to Do:

- Use your senses: sight, smell, hearing and touch.

Frequency:

- Check your machine periodically during your entire workday.
- Make sure to do your inspection the same way every time.
- Complete one of these inspections at the start and end of each shift.

N.B.-:IF DAMAGE OR UNAUTHORIZED MODIFICATIONS ARE DISCOVERED, THE MACHINE MUST BE REMOVED FROM SERVICE UNTIL REPAIRS ARE MADE BY A QUALIFIED SERVICE TECHNICIAN.

It is the owner's responsibility to ensure the required maintenance as recommended by Haulotte is completed prior to the operation of the machine.

If regular maintenance is not carried out, this may:

- Void the warranty.
- Cause machine malfunction.
- Reduce machine reliability and shorten its service life.
- Jeopardize operator safety.

HAULOTTE Services® technicians are specially trained to carry out extensive repairs, interventions or adjustments on the safety systems or elements of HAULOTTE® machines. They carry genuine HAULOTTE spare parts and tools as required, and also provide fully documented reports on all work completed.

The inspection and maintenance table, identifies the role and the responsibilities of each party in periodical machine maintenance.  C 3 - Inspection and Functional test.

2 Maintenance Schedule

This section provides the necessary information needed to place the machine in safe operation. In accordance with the regulations that are currently applicable, this machine is designed to have a 10 year life span in normal usage conditions. The life may be extended or reduced dependent on the severity of operating conditions, the machine condition itself and by conducting effective inspections and maintenance in addition to other external factors. There are a number of factors which can affect the design life including but not limited to, severity of operating conditions/routine maintenance which should be carried out in accordance with this manual.

Severity of operating conditions may require a reduction in time between maintenance periods. Machines that have been out of service or have not been in use for more than 3 months must undergo a periodic inspection before the machine is put back into service.

Maintenance must be carried out by a competent company or person familiar with mechanical procedures.

Maintenance operations performed must be recorded in a register / log book of the machine.

F - Maintenance

3 Inspection program

3.1 General program

The machine must be inspected on a regular basis at intervals of no less than once 1 per year. The purpose of the inspection is to detect any defect which could lead to an accident during routine use of the machine. Local standards and regulations may require more frequent inspections.

HAULOTTE® requires Reinforced and Major Inspections to be carried out on the product to extend its service life.

Inspections must be carried out by a competent company or person.

The inspection results must be recorded in the safety register or machine log book controlled and overseen by the company manager. This register or machine log book and the list of competent repair persons must be made available to the government work inspector and HAULOTTE Services®.

When	Person-in-charge	Stakeholder	What
Before sale	Owner (or renter)	Competent technician or qualified technician HAULOTTE Service®	Periodic inspection
Before rent	Owner (or renter)	Competent technician or qualified technician HAULOTTE Service®	Daily inspection
Before use or every change of user	Operator	Operator	Daily inspection
Annually (1 year)	Owner (or renter)	Competent technician or qualified technician HAULOTTE Service®	Periodic inspection
5 years	Owner (or renter)	Competent technician or qualified technician HAULOTTE Service®	Reinforced inspection
10 years	Owner (or renter)	Competent technician or qualified technician HAULOTTE Service®	Major inspection

3.2 Daily inspection

The Daily inspection includes a visual inspection, operational checks and testing of the safety systems. This must be conducted by the operator before using the machine.

This inspection is the responsibility of the user. Refer to  C 3.1 - Daily inspection.

3.3 Periodic inspection

The Periodic inspection is a thorough evaluation of the operation and safety features of the machine.

It must be conducted before the sale / resale of the machine and/or at least once every year.

Local regulations may have specific requirements on frequency, and content of inspections.

The severity of operating conditions may require frequent inspections.

This inspection is the responsibility of the owner, and inspections must be carried out by a competent company or person.

This inspection is in addition to the daily inspection.

This inspection should also be conducted after:

- Extensive dismantling and reassembly of major components.
- Repairs involving the machine's essential components.
- Any accident causing stress to the machine.

3.4 Reinforced inspection

The Reinforced inspection is a thorough evaluation of the machine's structural components, to ensure proper functionality of the machine.

This evaluation must occur at a frequency of 5000 hours or every 5 years.

This inspection is the responsibility of the owner, and it must be conducted by a HAULOTTE Services® technician or by a competent company or person.

This inspection includes:

- Daily inspection
- Periodic inspection

N.B.-:REFER TO THE MAINTENANCE MANUAL FOR DETAILS.

3.5 Major inspection

The Major inspection is a thorough evaluation of the machine's integrity and proper functioning; after a normal service life of 10 years.

This evaluation must take place after 10 years of operation and then repeated every 5 years thereafter.

The severity of operating conditions may require frequent inspections.

This inspection is the responsibility of the owner, and it must be conducted by a HAULOTTE Services® technician or by a competent company or person.

This inspection includes:

- Daily inspection
- Periodic inspection
- Reinforced inspection

N.B.-:REFER TO THE MAINTENANCE MANUAL FOR DETAILS.

4 Repairs and adjustments

Extensive repairs, interventions or adjustments on the safety systems or components must be performed by a HAULOTTE Services® technician. Use original spare parts and components only.

N.B.-HAULOTTE SERVICES® TECHNICIANS ARE TRAINED PROFESSIONALS TO PERFORM EXTENSIVE REPAIRS, INTERVENTIONS AND ADJUSTMENTS ON THE SAFETY SYSTEMS OR COMPONENTS OF HAULOTTE® MACHINES. THE TECHNICIAN CARRIES GENUINE HAULOTTE® SPARE PARTS AND TOOLS AS REQUIRED, AND ALSO PROVIDES FULLY DOCUMENTED REPORTS ON ALL WORK COMPLETED.

HAULOTTE Services® will not take responsibility for any outcomes resulting from inferior services or repairs performed by other unauthorised personnel.

HAULOTTE® reminds that NO modifications SHALL be carried out without the written permission of HAULOTTE®.

Any unauthorised repairs/modifications will void HAULOTTE® warranty.

To check for safety campaigns, consult our website: www.haulotte.com



N.B.-WHEN DISPOSING OR SCRAPPING THIS MACHINE, PLEASE CONSIDER APPROPRIATE METHODS OF RECYCLING. ANY ITEMS THAT REQUIRE SPECIFIC DISPOSAL ARE LISTED WITH INSTRUCTIONS IN THE MAINTENANCE MANUAL.

G - Other information

1	Conditions of warranty.....	3
2	Subsidiary contact information.....	4
2.1	California warning.....	5

G - Other information

1 Conditions of warranty

Our warranty conditions and extension contracts are now available on the websites of our sales network: www.haulotte.com







G - Other information

2 Subsidiary contact information

	<p>HAULOTTE FRANCE PARC DES LUMIERES 601 RUE NICEPHORE NIEPCE 69800 SAINT-PRIEST TECHNICAL Department: +33 (0)820 200 089 SPARE PARTS : +33 (0)820 205 344 FAX : +33 (0)4 72 88 01 43 E-mail : haulottefrance@haulotte.com www.haulotte.fr</p>		<p>HAULOTTE ITALIA VIA LOMBARDIA 15 20098 SAN GIULIANO MILANESE (MI) TEL: +39 02 98 97 01 FAX: +39 02 9897 01 25 E-mail : haulotteitalia@haulotte.com www.haulotte.it</p>		<p>HAULOTTE INDIA Unit No. 1205, 12th floor, Bhumiraj Costarica, Plot No. 1&2, Sector 18, Palm Beach Road, Sanpada, Navi Mumbai- 400 705 Maharashtra, INDIA Tel. : +91 22 66739531 to 35 E-mail : hlindia@haulotte.com www.haulotte.in</p>
	<p>HAULOTTE HUBARBEITSBÜHNEN GmbH Ehrenkirchener Strasse 2 D-79427 ESCHBACH TEL : +49 (0) 7634 50 67 - 0 FAX : +49 (0) 7634 50 67 - 119 E-mail : adv-gmbh@haulotte.com www.haulotte.de</p>		<p>HAULOTTE AUSTRALIA PTY Ltd 51 Port Link Drive DANDENONG - VIC - 3175 TEL : 1 300 207 683 FAX : +61 (0)3 9792 1011 E-mail : sales@haulotte.com.au www.haulotte.com.au</p>		<p>HAULOTTE DO BRASIL Av. Alameda Caiapós, 589 CEP: 06460-110 - TAMBORE BARUERI - SAO PAULO - BRASIL TEL : +55 11 4196 4300 FAX : +55 11 4196 4316 E-mail : haulottebrasil@haulotte.com www.haulotte.com.br</p>
	<p>HAULOTTE IBERICA C/ARGENTINA Nº 13 - P.I. LA GARENA 28806 ALCALA DE HENARES MADRID TEL : +34 902 886 455 TEL SAT : +34 902 886 444 FAX : +34 911 341 844 E-mail : iberica@haulotte.com www.haulotte.es</p>		<p>HAULOTTE POLSKA Sp. Z.o.o. UL. GRANICZNA 22 05-090 RASZYN - JANKI TEL : +48 22 720 08 80 FAX : +48 22 720 35 06 E-mail : haulottepolska@haulotte.com www.haulotte.pl</p>		<p>HAULOTTE MÉXICO, S.A. de C.V. Calle 40 SUR ESQUINA 13 ESTE No. S/N Colonia CIVAC, JUITEPEC, MORELOS CP 62578 México TEL : +52 77 7321 7923 FAX : +52 77 7516 8234 E-mail : haulotte.mexico@haulotte.com www.haulotte.com.mx</p>
	<p>HAULOTTE in JAPAN SBJ ShinOsaka BLDG 3F 4-6-5 Nishinakajima Yodogawa-ku, Osaka, JAPAN, Post Code: 532-0011 TEL : +81 6 6795 9008 FAX : +81 6 6795 9009 www.haulotte.com</p>		<p>HAULOTTE SINGAPORE Pte Ltd. No.26 CHANGI NORTH WAY, SINGAPORE 498812 Parts and service Hotline: +65 6546 6150 FAX : +65 6536 3969 E-mail : haulotteasia@haulotte.com www.haulotte.sg</p>		<p>HAULOTTE MIDDLE EAST FZE PO BOX 293881 Dubai Airport Free Zone DUBAI United Arab Emirates TEL : +971 (0)4 299 77 35 FAX : +971 (0) 4 299 60 28 E-mail : haulottemiddle-east@haulotte.com www.haulotte.ae</p>
	<p>HAULOTTE SCANDINAVIA AB Taljegårdsgatan 12 431 53 Mölndal SWEDEN TEL : +46 31 744 32 90 FAX : +46 31 744 32 99 E-mail : info@se.haulotte.com spares@se.haulotte.com www.haulotte.se</p>		<p>HAULOTTE TRADING (SHANGHAI) Co. Ltd. Room 606A, Tower 3, Ronshine Sunkwan Center Lane 77, Sunkun Road MINHANG DISTRICT SHANGHAI 201105 CHINA TEL : +86 21 6442 6607 FAX : +86 21 6442 6619 E-mail : haulotteshanghai@haulotte.com www.haulotte.cn</p>		<p>HAULOTTE ARGENTINA Ruta Panamericana Km. 34,300 (Ramal A Escobar) 1615 Gran Bourg (Provincia de Buenos Aires) Argentina TEL : +54 33 27 445991 FAX : +54 33 27 452191 E-mail : haulotteargentina@haulotte.com www.haulotte.com.ar</p>
	<p>HAULOTTE UK Ltd 1 Gravely Way Four Ashes Wolverhampton WV10 7GW ENGLAND TEL : +44 (0)1216 199753 FAX : +44 (0)1952 292758 E-mail : salesuk@haulotte.com www.haulotte.co.uk</p>		<p>HAULOTTE GROUP / BILJAX 125 TAYLOR PARKWAY ARCHBOLD, OH 43502 - USA TEL : +1 419 445 8915 FAX : +1 419 445 0367 Toll free : +1 800 537 0540 E-mail : sales@us.haulotte.com www.haulotte-usa.com</p>		<p>HAULOTTE NORTH AMERICA 3409 Chandler Creek Rd. VIRGINIA BEACH, VA 23453 - USA TEL : +1 757 689 2146 FAX : +1 757 689 2175 Toll free : +1 800 537 0540 E-mail : sales@us.haulotte.com www.haulotte-usa.com</p>
	<p>HAULOTTE NETHERLANDS BV Koopvaardijweg 26 4906 CV OOSTERHOUT - Nederland TEL : +31 (0) 162 670 707 FAX : +31 (0) 162 670 710 E-mail info@haulotte.nl www.haulotte.nl</p>				<p>HAULOTTE CHILE Panamerica Norte Altura Km 21,5 Colina (Cruce c/Lo Pinto) Santiago (RM) TEL : + 562 2 3727630 E-mail : haulotte-chile@haulotte.com www.haulotte-chile.com</p>

2.1 California warning

For the US destined machines (ANSI and CSA standards)

<p>CALIFORNIA</p>  <p>Proposition 65 Warning</p> <p>Operating, servicing and maintaining a passenger vehicle or off-road vehicle can expose you to chemicals including engine exhaust, carbon monoxide, phthalates, and lead, which are known to the State of California to cause cancer and birth defects or other reproductive harm. To minimize exposure, avoid breathing exhaust, do not idle the engine except as necessary, service your vehicle in a well-ventilated area and wear gloves or wash your hands frequently when servicing your vehicle.</p> <p>For more information go to  www.P65Warnings.ca.gov/passenger-vehicle</p>
<p>CALIFORNIE</p>  <p>Avertissement de la Proposition 65</p> <p>L'exploitation, l'entretien et la maintenance d'un véhicule de tourisme ou d'un véhicule tout-terrain peuvent vous exposer à des produits chimiques, y compris les gaz d'échappement, le monoxyde de carbone, les phthalates et le plomb, identifiés par l'État de Californie comme pouvant causer le cancer et des malformations congénitales ou autres effets nocifs sur la reproduction. Pour limiter toute exposition: évitez de respirer les gaz d'échappement, ne laissez pas tourner le moteur au ralenti sauf si nécessaire, faites l'entretien du véhicule dans une zone bien aérée et portez des gants ou lavez vous fréquemment les mains lors de cette opération.</p> <p>Pour de plus amples informations, consulter  www.P65Warnings.ca.gov/passenger-vehicle</p>
<p>CALIFORNIA</p>  <p>Advertencia de la Proposición 65</p> <p>Operar, dar servicio y mantenimiento a un vehículo de pasajeros o vehículo todo terreno puede exponerle a químicos incluyendo gases del escape, monóxido de carbono, ftalatos y plomo, los cuales son conocidos por el Estado de California como causantes de cáncer y defectos de nacimiento u otros daños reproductivos. Para minimizar la exposición, evite respirar los gases del escape, no encienda el motor excepto si es necesario, dé servicio a su vehículo en un área bien ventilada y utilice guantes o lave sus manos frecuentemente cuando dé servicio a su vehículo.</p> <p>Para mayor información visite  www.P65Warnings.ca.gov/passenger-vehicle</p>

For electric (battery operated) machines

CALIFORNIA



Proposition 65 Warning

Battery posts, terminals and related accessories contain lead and lead compounds, chemicals known to the State of California to cause cancer and reproductive harm. Batteries also contain other chemicals known to the State of California to cause cancer.
WASH HANDS AFTER HANDLING.

For more information go to  www.P65Warnings.ca.gov

CALIFORNIE



Avertissement de la Proposition 65

Les batteries, les bornes et autres accessoires contiennent du plomb et des composés à base de plomb, agents chimiques identifiés par l'État de Californie comme pouvant provoquer le cancer et des effets nocifs sur la reproduction. Les batteries contiennent également d'autres agents chimiques identifiés par l'Etat de Californie comme pouvant provoquer le cancer.
SE LAVER LES MAINS APRES MANIPULATION.

Pour de plus amples informations, consulter  www.P65Warnings.ca.gov

CALIFORNIA



Advertencia de la Proposición 65

Los bornes, los terminales y los accesorios de las baterías contienen plomo y compuestos de plomo, químicos conocidos por el Estado de California como causantes de cáncer y daños reproductivos. Las baterías también contienen otros químicos conocidos por el Estado de California como causantes de cáncer.

LAVESE LAS MANOS DESPUES DE MANIPULARLOS.

Para mayor información visite  www.P65Warnings.ca.gov

1 Intervention register..... 3

1 Intervention register

The intervention register keeps a record of maintenance and repair work carried out inside or outside the maintenance programme.

N.B.:-IN THE CASE OF A HAULOTTE SERVICES® INTERVENTION, THE QUALIFIED TECHNICIAN MUST INDICATE THE HAULOTTE SERVICES® INTERVENTION NUMBER.

Date	Type of intervention	Number of hours	Intervenor	Intervention number

