

LGMG SR0818E OPERATION MANUAL



Table of Contents

[Table of Contents](#)

[Foreword](#)

[Safety precautions](#)

[Danger](#)

[No Operation Except Following Cases](#)

[Dangers Classification](#)

[Design Intent](#)

[Maintenance of Safety Mark](#)

[Danger of Electric Shock](#)

Danger of Tip-Over

Safety of Work Area

Smashing and Pressing Hazards

Hazards of Operating on Slopes

Falling Hazards

Collision Hazards

Hazard of Component Damage

Hazard of Explosion and Fire

Hazard of Machine Damage

Hazard of Bodily Injuries

Battery Safety

Ground Information

Ground Control Unit (GCU)

Platform Control Unit (PCU)

Basic Operations

No Operation will be Allowed Before

Basic Principles

Pre-operation Inspection

No Operation, Except Following Cases

Basic Principles

Workplace Check

No Operation will be Allowed Before

Basic Principles

Functional Test

On the Ground Control Unit

Test on the platform control unit

Test the tilt sensor operation

No Operation will be Allowed Before

Basic Principles

Emergency Stop

Emergency Lowering

Operation on the Ground

Operation on the Platform

Driving on a Slope

Operation on the Ground Using the Platform Control Unit

Extending and Retracting of the Platform

How to Operate the Safety Arm

Auxiliary Descent

Fall Protection

Instructions for Battery and Charger

After Each Use

Compliance

Freewheel Configuration for Trailers

Fixed to a Truck or Trailer during Transportation

Ensure the Transportation Safety

Guidance for Lifting

Other ManualsLib Projects



Operation Manual

SR0818E/SR1018E/SR1218E/SR1418E

**Rough Terrain
Mobile Elevating Work Platform**



WARNING

Before operation and maintenance, the drivers and service personnel shall always read and thoroughly understand all information in this manual. Failure to do so may result in, fatal accidents or personal injury.

This manual must be kept with this machine at all times.

LINGONG HEAVY MACHINERY CO., LTD.

Rough Terrain Mobile Elevating Work Platform Operation Manual

880*1230 mm 16 format 8 printed sheets

Eighth edition August 2022 1st printed

Lingong Heavy Machinery Co., Ltd.

Add: 12th Floor, Building 3, Lushangguoaocheng, 9777 Jingshi Road, Lixia District, Jinan, China

Tel: 86-0531-67605017

Fax: 86-0531-67605017

Technical service: 86-0531-67605017

Web: www.LGMG.com.cn

Accessories sales: 86-0531-67605016

Contents

Foreword.....	IV
Safety precautions	V
Chapter 1 Safety	1
1.1 Danger.....	3
1.2 No Operation Except Following Cases	3
1.3 Dangers Classification	3
1.4 Design Intent	3
1.5 Maintenance of Safety Mark	3
1.6 Danger of Electric Shock	3
1.7 Danger of Tip-Over	4
1.8 Safety of Work Area.....	4
1.9 Smashing and Pressing Hazards.....	6
1.10 Hazards of Operating on Slopes	6
1.11 Falling Hazards.....	6
1.12 Collision Hazards.....	6
1.13 Hazard of Component Damage	7
1.14 Hazard of Explosion and Fire.....	7
1.15 Hazard of Machine Damage	7
1.16 Hazard of Bodily Injuries	7
1.17 Battery Safety	7
1.18 Ground Information.....	8
Chapter 2 Legend	11
Chapter 3 Label.....	15
Chapter 4 Specification	21
Chapter 5 Control Unit.....	35
5.1 Ground Control Unit (GCU).....	37
5.2 Platform Control Unit (PCU).....	39
5.3 Basic Operations	40
Chapter 6 Pre-operation Inspection.....	47
6.1 No Operation will be Allowed Before.....	49
6.2 Basic Principles	49
6.3 Pre-operation Inspection.....	49
Chapter 7 Workplace Check.....	51
7.1 No Operation, Except Following Cases.....	53
7.2 Basic Principles	53
7.3 Workplace Check.....	53
Chapter 8 Functional Test	55

8.1 No Operation will be Allowed Before.....	57
8.2 Basic Principles	57
8.3 Functional Test	57
8.4 On the Ground Control Unit	57
8.5 Test on the platform control unit.....	58
8.6 Test the tilt sensor operation.....	59
Chapter 9 Operation Instruction	61
9.1 No Operation will be Allowed Before.....	63
9.2 Basic Principles	63
9.3 Emergency Stop	63
9.4 Emergency Lowering	63
9.5 Operation on the Ground	63
9.6 Operation on the Platform.....	63
9.7 Driving on a Slope	64
9.8 Operation on the Ground Using the Platform Control Unit	65
9.9 Extending and Retracting of the Platform.....	65
9.10 How to Operate the Safety Arm	65
9.11 Auxiliary Descent.....	65
9.12 Fall Protection.....	65
9.13 Instructions for Battery and Charger	65
9.14 After Each Use.....	66
Chapter 10 Instructions for Transportation and Lifting	67
10.1 Compliance.....	68
10.2 Freewheel Configuration for Trailers	68
10.3 Fixed to a Truck or Trailer during Transportation.....	69
10.4 Ensure the Transportation Safety.....	69
10.5 Guidance for Lifting.....	69

Foreword

You are welcome to purchase and use the mobile elevating work platform produced by Lingong Heavy Machinery Co., Ltd. This machine is designed according to BS EN280-1:2022. This manual introduces the mechanism, drive and operation, maintenance and adjustment, technical parameters and maintenance adjustment data of mobile elevating work platform for safety guidance and proper operation and maintenance of the machine.

How to get the best benefit from the machine is the goal we pursue together with you, which to a great extent, depends on whether you are familiar with the machine and the maintenance is careful and comprehensive. We sincerely hope that you will be able to read this manual carefully before starting and operating the machine for the first time and before repairing and servicing the machine, and that you are familiar with the operation and maintenance described.

The illustrations and descriptions in this manual are correct at the time of publication, but the structure and performance of our products are constantly being improved. Changes in design, operation and maintenance instructions are subject to change without notice. For the latest information on the machine and questions about this manual, please consult our company.

This manual is applicable to mobile elevating work platform. Users should strictly follow the maintenance intervals specified in the maintenance schedule for maintenance.

This manual should always be placed at the specified location so that you can read it at any time. This manual is part of the machine. When the ownership or use right of the machine are transferred, please hand over this manual. If the manual is lost, damaged or illegible, please replace it in time!

This manual is copyrighted by Lingong Heavy Machinery Co., Ltd. and may not be copied or reproduced without the written permission of the company.



Only personnel who have been properly trained and qualified to operate or maintain this machine can operate, repair and maintain this machine.

Improper operation, maintenance, and repair are dangerous and can cause personal injury and death.

Before any operation or maintenance, the operator shall thoroughly read this manual. Do not operate, perform any maintenance or make any repairs on this machine before reading and understanding this manual.

The user shall load the platform strictly according to the load rating of the platform. Do not overload the platform or make any modifications to the platform without permission from LGMG.

The operation regulations and preventions in this manual are only applicable for the specified use of this machine.

Safety precautions

Operators should be aware of and follow the current national and local safety regulations, and if there are no national or local regulations, the safety instructions in this manual should apply.

Most of the accidents are caused by failure to follow the requirements on the machine operation and maintenance. In order to avoid accidents, please read, understand and follow all warnings and precautions in this manual and on the machine before operation and maintenance.

Safety precautions will be detailed in the “Safety” section of Chapter 1.

Since it is impossible to foresee all possible hazards, the safety instructions in this manual and on the machine may not include all safety precautions. If you use the procedures and operations not recommended in this manual, you must ensure that you and others are safe and the machine will not be damaged. If you are not sure about the safety of certain operations, please contact us or your dealer.

The precautions for operation and maintenance specified in this manual are applicable only when the machine is used for the intended purpose. If the machine is used for the purposes not covered in this manual, our company will not assume any responsibility for safety. The safety responsibility in such operations will be borne by the user and the operator.

Under no circumstances should the operations prohibited in this manual be performed.

The following markers are used to identify the safety information in this manual:



DANGER - If not avoided, the dangerous consequence may result in serious injury or death. This marker also means that if not avoided, it may cause serious damage to the machine.



WARNING - If not avoided, the potentially dangerous consequence may result in serious injury or death. This marker also means that if not avoided, it may cause serious damage to the machine.



CAUTION - If not avoided, it may cause mild or moderate injury. This marker also means that if not avoided, it may cause damage to the machine or shorten the life of the machine.

Chapter 1 Safety

1.1 Danger

Failure to disobey the instructions and safety rules in this manual may cause death or serious injuries.

1.2 No Operation Except Following Cases

You have known and practiced the rules for safe operation of machine in the Operation Manual.

- 1) Avoid the dangers. Know and understand the safety rules before next step.
- 2) Always check before operation.
- 3) Always perform the function test before operation.
- 4) Check the work place.
- 5) Use the machine only as per the design intent of the machine.
- 6) Read, understand and obey the instructions and safety rules of manufacturer-safe operation manual and machine label.
- 7) Read, understand and obey the safety rules for users and regulations of work site.
- 8) Read, understand and obey all applicable government laws and regulations.
- 9) You need to accept proper training for safe operation of the machine.

1.3 Dangers Classification



NOTICE:

Classification of hazards

The meanings of symbols, color codes and characters of LGMG's products are as follows:

Security warning symbol: are used for warning of potential personal injuries. Observe all safety instructions below these signs, to avoid situations causing potential personal injury and death.



Red: Signifies dangerous situations. If

not avoided, will result in personal death or severe injury.



Orange: Signifies dangerous situations. If not avoided, may result in personal death or severe injury.



Yellow: Signifies dangerous situations. If not avoided, may result in minor or intermediate personal injury.



Blue: Signifies dangerous situations. If not avoided, property loss or damage can occur.

1.4 Design Intent

The use of the machine is only limited to lift staff, tools and materials to the high work place.



NOTICE: It is forbidden to carry cargo.

1.5 Maintenance of Safety Mark

- 1) Replace any lost or damaged safety mark to make the operator remember the safety at any time.
- 2) Wash the safety mark by mild soap and clean water.
- 3) Do not use solvent cleaner since it may damage the materials of the safety mark.

1.6 Danger of Electric Shock

- 1) The machine is not insulated, and does not provide the electrical shock protection when contacting or being closed to the wire.

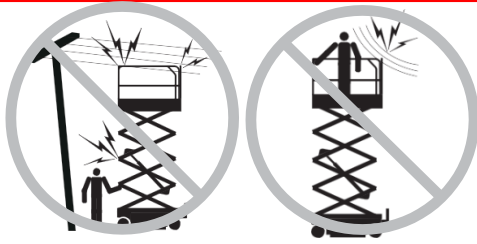

Keep enough safety distance from the machine to the power supply line and electric machine according to the applicable government laws and regulations, and instructions of the following table.

Voltage	Required safety distance
0-50 KV	3.05 m
50 KV-200 KV	4.6 m
200 KV-350 KV	6.10 m
350 KV-500 KV	7.62 m
500 KV-750 KV	10.67 m
750 KV-1,000 KV	13.72 m

- 2) Beware of strong winds or gusts. Consider the factors such as platform movement, wire swing or droop.
- 3) If the machine contacts the wire with power, please be far away from the machine. Staff on the ground or platform is forbidden to contact or operate the machine before cutting off the power supply.
- 4) Do not operate the machine when there is lightning or storm.
- 5) Do not use the machine as the ground wire during welding.

1.7 Danger of Tip-Over

Staff, equipment and materials on the platform cannot exceed the maximum bearing capacity of the platform and extension platform.

Item	SR0818E	
Maximum capacity	Indoor: 4 persons	Outdoor: 4 persons
Maximum operating load of platform	680kg	680Kg
Recommended Load capacity of extension deck	140kg	140Kg

Item	SR1018E	
Maximum capacity	Indoor: 4 persons	Outdoor: 2 persons
Maximum operating load of platform	454kg	454Kg
Recommended Load capacity of extension deck	140kg	140Kg

Item	SR1218E	
Maximum capacity	Indoor: 3 persons	Outdoor: 2 persons
Maximum operating load of platform	365kg	365Kg
Recommended Load capacity of extension deck	140kg	140Kg

Item	SR1418E	
Maximum capacity	Indoor: 2 persons	Outdoor: 2 persons
Maximum operating load of platform	365kg	365Kg
Recommended Load capacity of extension deck	140kg	140Kg

1.8 Safety of Work Area

- 1) The platform can only be raised on a solid and flat level ground.



- 2) The speed shall not exceed 0.5 km/h when the platform is raised.
- 3) The inclination alarm cannot be regarded as level indicator. When the machine is seriously inclined, the inclination alarm of the chassis and platform will ring.
- 4) If inclination alarm rings, lower the platform

and move the machine to a solid level ground. If the inclination alarm rings when the platform is raised, the platform shall be lowered very carefully.

- 5) In case the machine is used outdoor, do not lift the platform when the wind speed is above 12.5m/s. If the wind speed exceeds the limit after lifting the platform, please immediately lower the platform and stop the machine operation.
- 6) Do not operate the machine in strong winds or gusts. The surface area of the platform or load cannot be increased. Increase of the area exposed to the wind will reduce the stability of the machine.

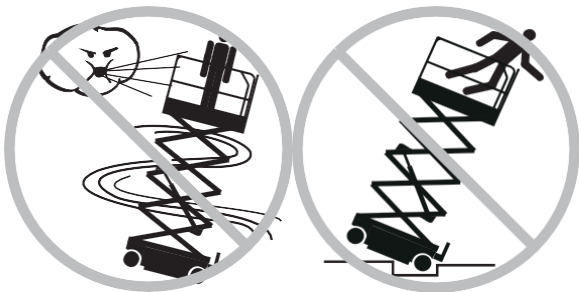

- 7) In the raising state of the platform, the machine cannot run on uneven terrain and unstable surface, or in other dangerous situations, or near these areas.
- 8) In the folding state, the machine must run very carefully and reduce its speed when it runs on uneven terrain, unstable or smooth surface with stones, or the place near the tunnel, or the steep slope.
- 9) Do not use the platform control unit (PCU) to release the platform when the platform is tripped, stuck, or its normal operation is obstructed by other nearby matters. Before using the ground control unit (GCU) to release the platform, all staff must leave the platform.
- 10) Don't push or pull anything outside the platform.



Maximum allowable manual force

Model	Manual Force
SR0818E	Indoor: 400N Outdoor:400N
SR1018E	Indoor: 400N Outdoor:400N
SR1218E	Indoor: 400N Outdoor:400N
SR1418E	Indoor: 400N Outdoor:400N

- 11) Don't use the machine as a crane.
- 12) Don't place, fasten and fix or suspend loads on any component of the machine.

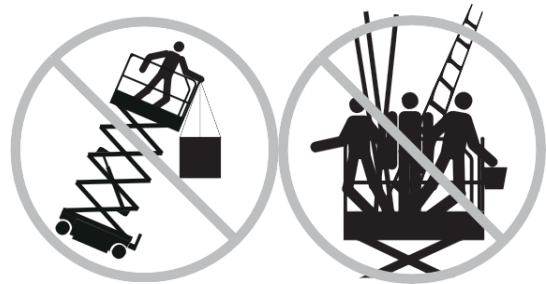

- 13) Don't place ladders or scaffolds within the platform or against any component of the machine.
- 14) Don't attach platforms to adjacent buildings.
- 15) Don't change or disable limit switch.
- 16) Don't tie platforms to adjacent components.
- 17) Don't place loads outside the platform guardrail.
- 18) Don't change or damage any component that may affect the safety and stability of the machine.
- 19) Don't replace key parts that affect machine stability with parts of different weights or specifications.
- 20) Don't amend or modify the aerial work platform. Install additional equipment for placing tools or other materials on platforms, pedals or guardrails, which will increase platform weight and surface area or load.
- 21) Don't push machines or other objects on the platform.
- 22) Only transport tools and materials that are evenly distributed and can be safely moved by people on the platform.
- 23) Don't use machines on moving surfaces and vehicles.
- 24) Ensure that all tires are in good condition and nuts have been properly tightened.
- 25) Ambient temperature for machine operation

is -20°C-40°C.



- 26) Ambient relative humidity for machine operation shall be no greater than 90% (at 20°C)
- 27) The allowable fluctuation of machine power supply voltage is ±10%.
- 28) Total vibration value to which the hand/arm system is subjected does not exceed 2.5 m/s². Highest root mean square value of weighted acceleration to which the whole body is subjected does not exceed 0.5 m/s².

1.9 Smashing and Pressing Hazards

- 1) Don't move your hands and arms near parts that are in danger of cutting or smashing, and keep them out of scissors arms.
- 2) Don't place your hands in a position where you may get pinched when folding the guardrail.
- 3) Grasp the platform guardrail all the time when removing the pins fixed on the guardrail. Don't let the platform guard railing fall off.
- 4) Please maintain good judgment and planning when operating the machine with controllers on the ground. Maintain a safe distance among operators, machines and stationary objects.

1.10 Hazards of Operating on Slopes

Don't drive the machine on slopes that exceed the ratings of machine slopes and side slopes. Slope ratings are applicable to machines in a Stowed state.

Item	SR1018E SR1218E SR1418E	SR0818E
 Maximum slope rating in the retracted state	35%(19 °)	40%(22 °)
 Maximum side	35%(19 °)	40%(22 °)

slope rating in the retracted state		
-------------------------------------	--	--

1.11 Falling Hazards

- 1) During operation, the operator on the platform must wear a full body safety device and be secured on approved rope anchorage points with safety strap hooks. Each rope anchorage point can only be tied with one hook.



- 2) Don't climb or stand on the platform guard railing. Stand firmly on the platform floor at all times.
- 3) Don't climb down from the platform when the platform is lifted.
- 4) Keep the platform floor free from debris.
- 5) Please close the entrance door before operation.
- 6) Don't operate the machine if guard railings are not installed properly or safe operation cannot be guaranteed at the entrance door.
- 7) Don't move in and out of the platform unless the machine is in a folding state.

1.12 Collision Hazards

- 1) Pay attention to range of visibility and blind spots when starting or manipulating the machine.
- 2) Pay attention to the position of the extension platform when moving the machine.
- 3) Check the operation areas to avoid obstacles overhead or other possible hazards.
- 4) Be careful of extrusion hazards when grasping the platform guard railing.
- 5) Users must comply with service regulations of personal protection equipment as required by the employer, in workplace and stipulated in government laws and regulations.

- 6) Observe and use the direction arrows of driving and steering functions on the PCU and platform labels when driving and steering.
- 7) Don't operate the machine on any running route of crane or high-altitude machinery unless the crane controller has been locked and/or precautions have been taken to prevent any potential collision.
- 8) Prohibit dangerous driving or play when the machine is operated.
- 9) It is allowed to lower the platform when there are no staff and obstacles in the area under the platform.



- 10) Restrict driving speed according to ground condition, jamming degree, gradient, staff position and any other factors that may cause collision.
- 11) Recommend the operator to wear qualified safety helmet when the machine is operated.

1.13 Hazard of Component Damage

- 1) Do not use the machine as the ground wire during welding.
- 2) Do not use the machine in the place where there may be magnetic field.

1.14 Hazard of Explosion and Fire

- 1) Do not use the machine in hazardous place or the place where there may be inflammable or explosive gas or particles.
- 2) It is allowed to charge the battery only in the open and well-ventilated places far away from sparks, flames, burning cigarettes, etc.
- 3) Do not operate or charge the machine at the location with possible inflammable or explosive gas or particles.

1.15 Hazard of Machine Damage

- 1) Do not use the damaged or faulted machine.
- 2) Be sure to perform a thorough check before operation of machine and test all functions before each shift. The damaged or faulted machine shall be marked immediately, and the operation shall be stopped.
- 3) Ensure that all maintenance operations have been performed as specified in this manual.
- 4) Ensure that all labeling positions are proper and easy to be identified.
- 5) Ensure that this manual is stored in document box on the platform.

1.16 Hazard of Bodily Injuries

- 1) Do not operate the machine when hydraulic oil or air leaks. Leakage of hydraulic oil or air may penetrate or burn the skin.
- 2) Always operate the machine in a well-ventilated place to avoid poisoning of carbon monoxide.
- 3) Wrong contact with any component under the cover may cause serious injuries. Trained maintainers are only allowed to overhaul the compartment. Suggestion: Only when the check before operation is performed, can operator overhaul the compartment. During operation, all compartments must be closed and locked.

1.17 Battery Safety

Combustion Hazard

- 1) The battery contains acidic substances. Be sure to wear protective clothing and protective glasses when the battery is used.
- 2) Avoid overflow of acidic substance or contact with it in the battery. Use soda and water to neutralize the overflowing acidic substances in the battery.
- 3) Avoid exposition of the battery or charger to water or rain during charging.
- 4) If the vehicle is parked for a long time, disconnect the main power switch.

Explosion Hazard

- 1) Prohibit sparks, flames, and lighted cigarettes to be near the battery, because the battery can release explosive gas.

- 2) Do not use tools that may cause sparks to contact battery terminal or cable clamp.

Component damage hazard

Do not charge the battery with any above 48V battery charger.

Electric shock/ burn hazard

- Only connect the battery charger to a grounded AC three wire power outlet.
- Check cables, cables and wiring daily for damage. Replace damaged items before operation.

Tip-over Hazard

It is forbidden to use a battery weighing less than the original battery. The battery installed on the chassis is used as counterweight and is vital for the stability of machine. Every battery has a different weight (as detailed in the following table).

Model	Battery weight (Kg)
SR0818E	40
SR1018E	
SR1218E	
SR1418E	47

Lifting Hazard

Use the appropriate number of people and proper lifting techniques when lifting batteries.

1.18 Ground Information



WARNING: Rollover and personal

injury will be caused under severe working conditions and complex and unsafe ground conditions, and stable ground conditions and good working conditions can ensure the normal operation of the machine; therefore before operation, verify that the ground in the working area is safe and strong enough to support the machine.



DANGER: Rollover and personal

injury may occur under the following conditions:

- on steep slopes or in caves;
- when there are protrusions, obstacles or debris on the ground;
- on the inclined surface;
- on the unstable or smooth surface;
- near the mining area where the soil foundation is soft soil;
- on saturated soil or frozen soil;
- on suspended floor;
- on kerbs and road edges;
- on surface support that is not strong enough to withstand the full load of the machine;
- under other possible unsafe situations.

The ground load bearing information of the machine is shown in the table below:

Model	Tire contact pressure (kPa)	Ground pressure of tire (kPa)	Ground pressure of outrigger (kPa)
SR0818E (Without outrigger)	492.07	8.01	-
SR1018E	526.37	8.75	7.16
SR1218E	577.09	9.95	8.15
SR1418E	651.95	11.74	9.88



CAUTION: The ground load

bearing information given herein is for reference only, and does not consider the optional devices of the machine. Before using the machine, always verify that the ground of the working area is safe and strong enough to support the machine.

Tire specification:

Model	Drive wheel load-6km/h (Kg)	Maximum static load (Kg)
SR0818E	2060	3000
SR1018E	2060	3000
SR1218E	2060	3000
SR1418E	2060	3000

Chapter 2 Legend

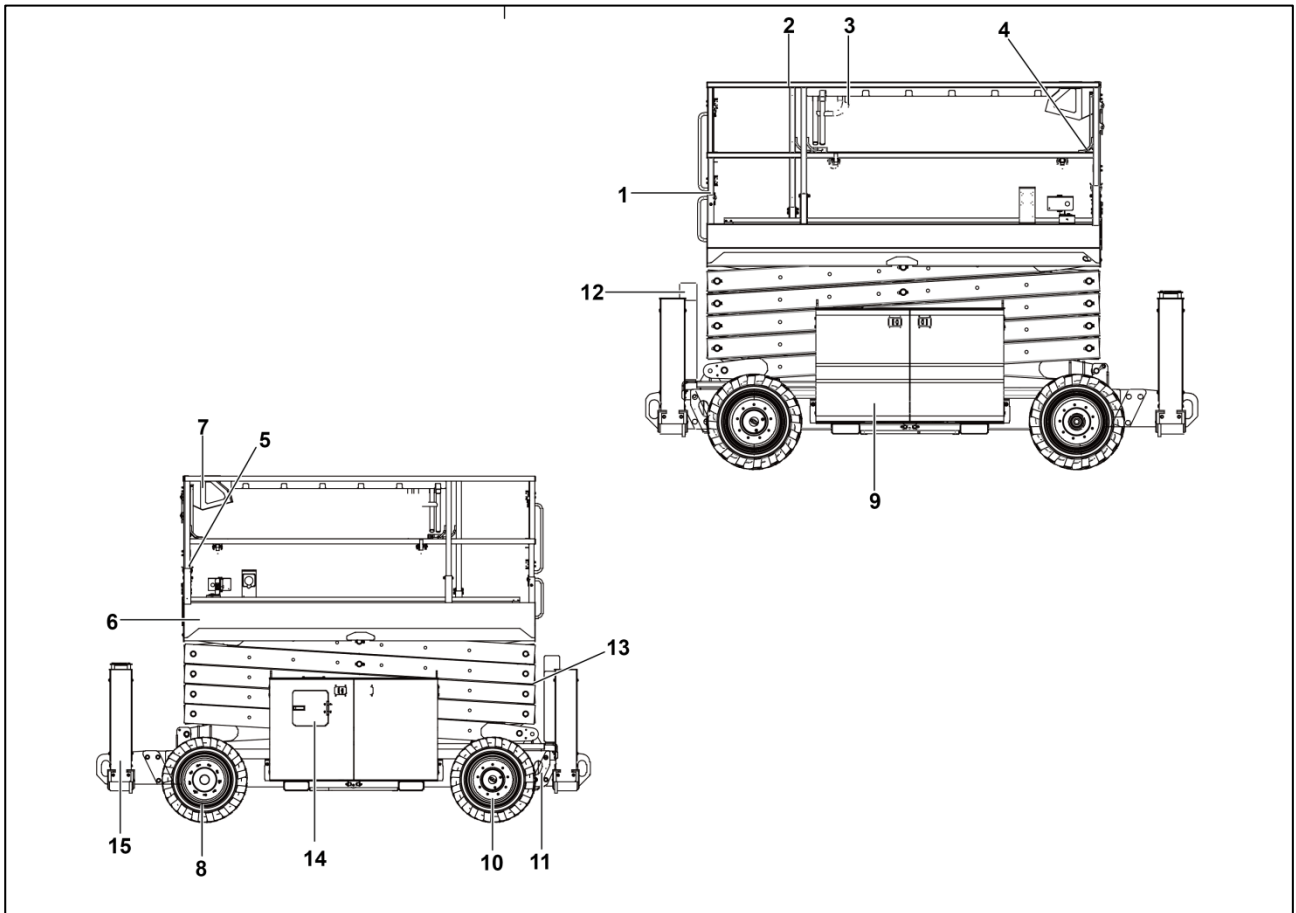

No.	Name	No.	Name
1	Platform entrance door	9	Battery side
2	Platform fence	10	Non-steering wheel
3	Platform extension locking handle	11	Transport tie point
4	Tackle fixing point	12	Entrance ladder
5	File box	13	Safety arm
6	Extension platform	14	Lower control box and Hydraulic valve component
7	Platform control unit	15	Outrigger (If equipped)
8	Steering wheel		

Chapter 3 Label

SR0818E/SR1018E/SR1218E/SR1418E Label

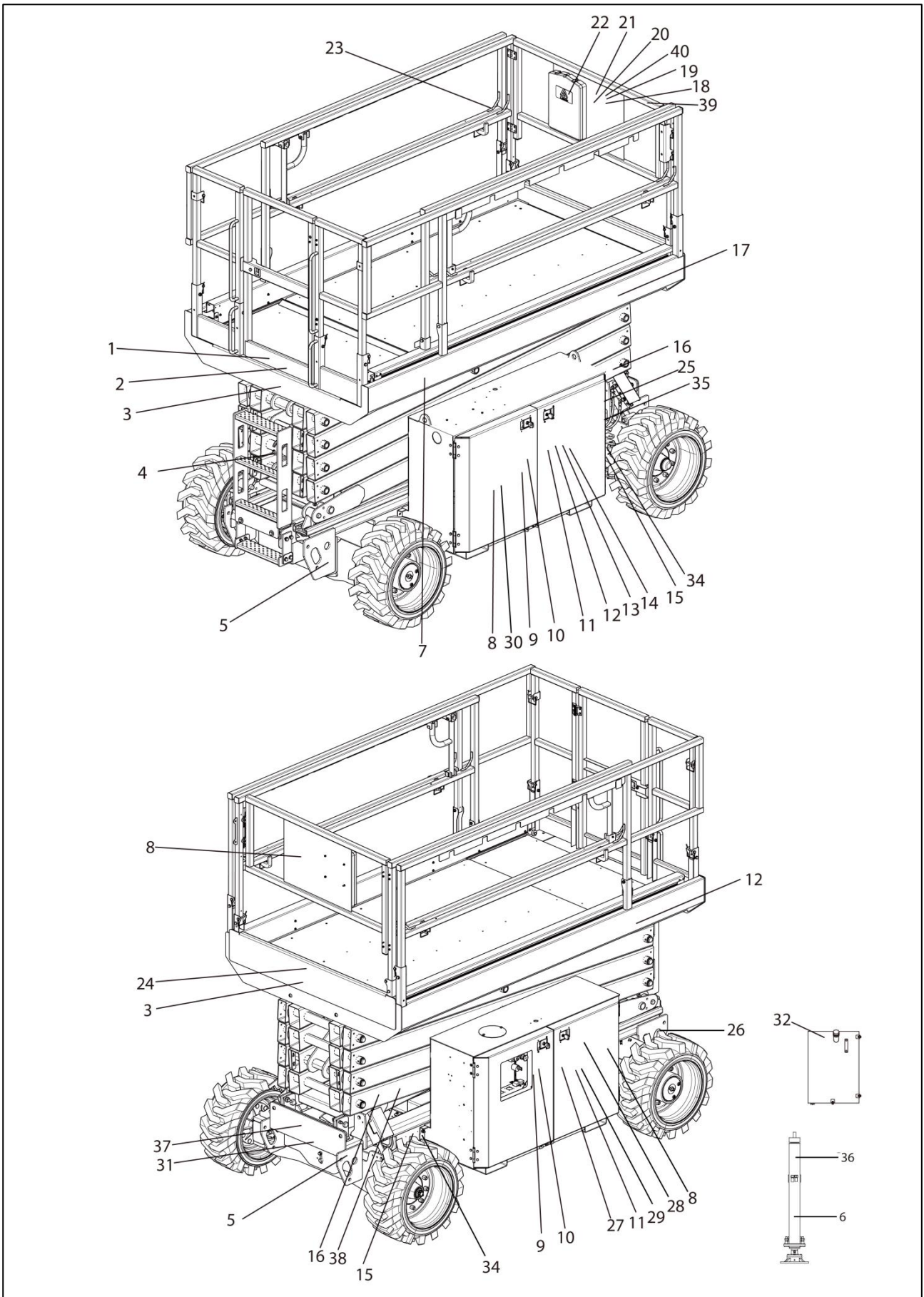

SR0818E/SR1018E/SR1218E/SR1418E Label

1-2534000390/1003/2504/2295	2-2534000179	3-2534000024	4-2534000032	5-2831990027	6-2534002158
7-2534000218	8-2534000220	9-2534000022	10-2534000011	11-2534000009	12-2534000029
13-2534000004	14-2534000008	15-2534000102	16-2534000019	17-2534001201/1202/2501/2640	18-2534000172
				SR1218E SR1018E SR0818E SR1418E	
19-2534000033	20-2534000229	21-2534000013	22-2534000119	23-2534000017	24-2534000272
					I P A F
25-2534000018	26-2534000034	27-2534000145	28-2534000167	29-2534000276	30-2534001166
		<p>WARNING THIS MACHINE MUST NOT BE USED UNTIL IT IS INSPECTED AND OPERATING PROPERLY. 1 Do not operate, repair and maintenance on the platform unless you are trained and qualified. 2 Any failure to follow safety or operation, repair and maintenance can result in injury and death. 3 Do not perform operation until all maintenance procedure unless you read, understand the manual completely. 4 To check before the start loading capacity, any compensation device to ensure and/or modification should be acceptable by the user. 5 The operation procedure and precaution should be taken and well explained to the special operator of the machine. Be always assured that any operator out of the specification but not prohibited will not be anyone.</p>	<p>WARNING Pressurized vessel Discharge prior to disassembly. Use only nitrogen or other inert gases pre-charging medium. Do not knock, drill and weld the accumulator. Keep it away from the hot source or sparks.</p>		
31-2534001173	32-2534001377	33-2534001610	34-2534001922	35-2534002181	36-2534003526
	<p>Max</p> <p>Min</p>				

SR0818E/SR1018E/SR1218E/SR1418E Label List

No.	Code	Name
1	2534000390/1003/2504/2295	Rated load -SR1218E/SR1018E/SR0818E/SR1418E
2	2531000179	Maximum hand force sign
3	2534000024	Warning line
4	2534000032	Forklift safety arm sign
5	2831990027	Lifting lug sign
6	2534002158	Outrigger load
7	2534000218	Group LOGO
8	2534000220	Group LOGO
9	2534000022	Crash hazard
10	2534000011	Caution-Compartment Access
11	2534000009	Label-Electrocution Hazard
12	2534000029	Label-Skin Injection Hazard
13	2534000004	Exploding and burn hazard
14	2534000008	Danger-Tip-over
15	2534000102	Label-Directional Arrows
16	2534000019	Away from the machine warning sign
17	2534001201/1202/2501/2640	Cosmetic-SR1218E/SR1018E/SR0818E/SR1418E
18	2534000172	Danger
19	2534000033	Direction arrow sign
20	2534000229	Prohibition sign
21	2534000013	Platform lowering warning sign
22	2534000119	Instructions reading sign
23	2534000017	Tackle fixed point sign
24	2534000272	IPAF sign
25	2534000018	Charge the battery
26	2534000034	Emergency lowering
27	2534000145	Warning signs
28	2534000167	Energy accumulator
29	2534000276	Label-CE
30	2534001166	Danger
31	2534001173	Label-Transport Tie-down
32	2434001377	Oil sign
33	2534001610	Whole machine nameplate
34	2534001922	Wheel load
35	2534002181	Turn off the power
36	2534003526	Decal-Ground check
37	2534000015	Decal-Tilt hazard
38	2534003478	Decal-Risk of pinching hand
39	2534003479	Decal-handrail position
40	2534000791	Decal-Risk of outrigger

Chapter 4 Specification

Specification

SR0818E (S081800WDQ0CE3000) machine parameters

Machine performance parameters

Item	Parameter	Item	Parameter
Rated load (kg)	680	Lifting speed (S)	35±4
Recommended Load capacity of extension deck (kg)	140	lowering speed (S)	30±4
Machine weight (kg)	3720	Maximum manual force	indoor (N) 400
Maximum number of people (in door)	4		outdoor (N) 400
Maximum number of people (out door)	4	Maximum outrigger leveling angle (front to rear) (if equipped)	5.7°
Maximum working height (m)	9.7	Maximum outrigger leveling angle (left to right) (if equipped)	12°
Maximum platform height (m)	7.7	Maximum allowable working angle (front and rear)	3°
Minimum turning radius (m)	4.75	Maximum allowable working angle (left and right)	2°
Machine travel speed (in the retracted state) (km/h)	6.1±0.2	Maximum allowable wind speed(m/s)	12.5
Machine travel speed (in the lifting state) (km/h)	1.1±0.1	Drive mode	Rear-wheel drive
Theoretical climbing ability	40%		Front wheel steering
Braking distance (no-load stowed) (m)	1.5		

Main dimensions

Item	Parameter	Item	Parameter
Machine length-with ladder (mm)	3110	Extended platform size (mm)	1520
Machine length-without ladder (mm)	3020	Wheelbase (front/rear) (mm)	2290
Machine width (mm)	1790	Tread(mm)	1507
Machine height - platform guide rail unfolded (mm)	2580	Ground clearance (lifted) (mm)	230
Machine height - platform guide rail folded (mm)	1890	Tire size (diameter x width) (mm)	Φ663x283
Main platform size (length x width) (mm)	2790x1600		

Drive system

Item		Specification/Content
Traveling reducer	Rated output torque (N.m)	3500

Hydraulic system

Item		Specification/Content
Function system	Model	Open system
	Pump displacement (ml/r)	4.5
	Lifting system	Max working pressure (Mpa) 19.7
	Steering system	Max working pressure (Mpa) 10.3
	Floating system	Max working pressure (Mpa) 22.8

Electrical System

Item		Specification/Content
Drive motor	Rated Voltage (V)	29
	Rated current (A)	125
	Rated power (kW)	3.56
	Rated speed (r/min)	3400
Lifting motor	Rated Voltage (V)	48
	Rated current (A)	330
	Rated power (kW)	8.9
	Rated speed (r/min)	3290
Battery	Output voltage (V)	6
	Capacity (Ah)	315 (20 hours)
Charger	Nominal AC input voltage (V)	85-265 AC
	Maximum AC input current (A)	15
	Nominal DC output voltage (V)	48
	Maximum DC output current (A)	35
Control system	Voltage (V)	24

Oil capacity

Item	Parameter
Hydraulic oil (L)	50
Traveling reducer gear oil(L)	0.68*2

Note: The corresponding hydraulic oil should be selected according to the environment and temperature when adding hydraulic oil. Refer to the following:

Item	Condition	Oil viscosity brand	Remarks
Hydraulic oil	-25℃ < The lowest	L-HV 32 low	Recommended

	temperature	temperature hydraulic oil	chevron brand
	-40°C < The lowest temperature ≤ -25°C	L-HS 32 Ultralow temperature hydraulic oil	
	The lowest temperature ≤ -40°C	10# Aviation hydraulic oil	
Driving Reducer oil	30° C < The lowest temperature	85W/140	API GL-5
	-10° C < The lowest temperature < 30° C	85W/90	
	-30° C < The lowest temperature < -10° C	80W/90	
	The lowest temperature < -30° C	75W	

Specification

SR1018E (S10181DTCE30) machine parameters

Machine performance parameters

Item	Parameter	Item	Parameter
Rated load (kg)	454	Lifting speed (S)	39 ± 4
Recommended Load capacity of extension deck (kg)	140	lowering speed (S)	46 ± 4
Machine weight (kg)	4350	Maximum manual force	indoor (N) 400
Maximum number of people (in door)	4		outdoor (N) 400
Maximum number of people (out door)	2	Leveling angle(Front and rear)	5.7° /5.5°
Maximum working height (m)	11.7	Leveling angle(Left and right)	12°
Maximum platform height (m)	9.7	Maximum allowable working angle (front and rear)	3°
Minimum turning radius (m)	4.75	Maximum allowable working angle (left and right)	2°
Machine travel speed (in the retracted state) (km/h)	6.1 ± 0.5	Maximum allowable wind speed(m/s)	12.5
Machine travel speed (in the lifting state) (km/h)	0.5 ± 0.2	Drive mode	Rear-wheel drive
Theoretical climbing ability	35%		Front wheel steering
Braking distance (no-load stowed) (m)	1.5		

Main dimensions

Item	Parameter	Item	Parameter
Machine length (mm)	3760	Extended platform size (mm)	1520
Machine width (mm)	1790	Wheelbase (front/rear) (mm)	2290
Machine height - platform guide rail unfolded (mm)	2550	Tread(mm)	1507
Machine height - platform guide rail folded (mm)	1890	Ground clearance (lifted) (mm)	230
Main platform size (length × width) (mm)	2790×1600	Tire size (diameter × width) (mm)	Φ663×283

Drive system

Item		Specification/Content
Traveling reducer	Rated output torque (N*m)	3500

Hydraulic system

Item		Specification/Content
Function system	Model	Open system
	Pump displacement (ml/r)	4.5
	Lifting system	Max working pressure (Mpa) 19.7
	Steering system	Max working pressure (Mpa) 10.3
	Floating system	Max working pressure (Mpa) 22.8

Electrical System

Item		Specification/Content
Drive motor	Rated Voltage (V)	29
	Rated current (A)	125
	Rated power (kW)	3.56
	Rated speed (r/min)	3400
Lifting motor	Rated Voltage (V)	48
	Rated current (A)	330
	Rated power (kW)	8.9
	Rated speed (r/min)	3290
Battery	Output voltage (V)	6
	Capacity (Ah)	315 (20 hours)
Charger	Nominal AC input voltage (V)	85-265 AC
	Maximum AC input current (A)	15
	Nominal DC output voltage (V)	48
	Maximum DC output current (A)	35
Control system	Voltage (V)	24

Oil capacity

Item	Parameter
Hydraulic oil (L)	50
Traveling reducer gear oil(L)	0.68*2

Note: The corresponding hydraulic oil should be selected according to the environment and temperature when adding hydraulic oil. Refer to the following:

Item	Condition	Oil viscosity brand	Remarks
Hydraulic oil	-25℃ < The lowest temperature	L-HV 32 low temperature hydraulic oil	Recommended chevron brand
	-40℃ < The lowest temperature ≤ -25℃	L-HS 32 Ultralow temperature hydraulic oil	
	The lowest temperature ≤ -40℃	10# Aviation hydraulic oil	

Driving Reducer oil	30° C < The lowest temperature	85W/140	API GL-5
	-10° C < The lowest temperature < 30° C	85W/90	
	-30° C < The lowest temperature < -10° C	80W/90	
	The lowest temperature < -30° C	75W	

Specification

SR1218E (S12181DTCE30) machine parameters

Machine performance parameters

Item	Parameter	Item	Parameter
Rated load (kg)	365	Lifting speed (S)	61 ± 4
Recommended Load capacity of extension deck (kg)	140	lowering speed (S)	55 ± 4
Machine weight (kg)	5100	Maximum manual force	indoor (N) 400
Maximum number of people (in door)	3		outdoor (N) 400
Maximum number of people (out door)	2	Leveling angle(Front and rear)	5.7° /5.5°
Maximum working height (m)	13.9	Leveling angle(Left and right)	12°
Maximum platform height (m)	11.9	Maximum allowable working angle (front and rear)	3°
Minimum turning radius (m)	4.75	Maximum allowable working angle (left and right)	2°
Machine travel speed (in the retracted state) (km/h)	6.1 ± 0.5	Maximum allowable wind speed(m/s)	12.5
Machine travel speed (in the lifting state) (km/h)	0.5 ± 0.2	Drive mode	Rear-wheel drive
Theoretical climbing ability	35%		Front wheel steering
Braking distance (no-load stowed) (m)	1.5		

Main dimensions

Item	Parameter	Item	Parameter
Machine length (mm)	3760	Extended platform size (mm)	1520
Machine width (mm)	1790	Wheelbase (front/rear) (mm)	2290
Machine height - platform guide rail unfolded (mm)	2700	Tread(mm)	1507
Machine height - platform guide rail folded (mm)	2040	Ground clearance (lifted) (mm)	230
Main platform size (length x width) (mm)	2790×1600	Tire size (diameter x width) (mm)	Φ663×283

Drive system

Item		Specification/Content
Traveling reducer	Rated output torque (N.m)	3500

Hydraulic system

Item		Specification/Content
Function system	Model	Open system
	Pump displacement (ml/r)	4.5
	Lifting system	Max working pressure (Mpa) 19.7
	Steering system	Max working pressure (Mpa) 10.3
	Floating system	Max working pressure (Mpa) 22.8

Electrical System

Item		Specification/Content
Drive motor	Rated Voltage (V)	29
	Rated current (A)	125
	Rated power (kW)	3.56
	Rated speed (r/min)	3400
Lifting motor	Rated Voltage (V)	48
	Rated current (A)	330
	Rated power (kW)	8.9
	Rated speed (r/min)	3290
Battery	Output voltage (V)	6
	Capacity (Ah)	315 (20 hours)
Charger	Nominal AC input voltage (V)	85-265 AC
	Maximum AC input current (A)	15
	Nominal DC output voltage (V)	48
	Maximum DC output current (A)	35
Control system	Voltage (V)	24

Oil capacity

Item	Parameter
Hydraulic oil (L)	50
Traveling reducer gear oil(L)	0.68*2

Note: The corresponding hydraulic oil should be selected according to the environment and temperature when adding hydraulic oil. Refer to the following:

Item	Condition	Oil viscosity brand	Remarks
Hydraulic oil	-25°C < The lowest temperature	L-HV 32 low temperature hydraulic oil	Recommended chevron brand
	-40°C < The lowest temperature ≤ -25°C	L-HS 32 Ultralow temperature hydraulic oil	
	The lowest temperature ≤ -40°C	10# Aviation hydraulic oil	
Driving Reducer oil	30° C < The lowest	85W/140	API GL-5

	temperature		
	-10° C<The lowest temperature<30° C	85W/90	
	-30° C<The lowest temperature<-10° C	80W/90	
	The lowest temperature<-30° C	75W	

Specification

SR1418E (S141800WDQ0CE3001) machine parameters

Machine performance parameters

Item	Parameter	Item	Parameter
Rated load (kg)	365	Lifting speed (S)	80±2
Recommended Load capacity of extension deck (kg)	140	lowering speed (S)	60±2
Machine weight (kg)	6260	Maximum manual force	indoor (N) 400
Maximum number of people (in door)	2		outdoor (N) 400
Maximum number of people (out door)	2	Leveling angle(Front and rear)	5.7°
Maximum working height (m)	15.8	Leveling angle(Left and right)	12°
Maximum platform height (m)	13.8	Maximum allowable working angle (front and rear)	3°
Minimum turning radius (m)	4.75	Maximum allowable working angle (left and right)	2°
Machine travel speed (in the retracted state) (km/h)	6.1±0.5	Maximum allowable wind speed(m/s)	12.5
Machine travel speed (in the lifting state) (km/h)	0.5±0.2	Drive mode	Rear-wheel drive
Theoretical climbing ability	35%		Front wheel steering
Braking distance (no-load stowed) (m)	1.5		

Main dimensions

Item	Parameter	Item	Parameter
Machine length (mm)	3730	Extended platform size (mm)	1500
Machine width (mm)	1840	Wheelbase (front/rear) (mm)	2290
Machine height - platform guide rail unfolded (mm)	2900	Tread(mm)	1557
Machine height - platform guide rail folded (mm)	2240	Ground clearance (lifted) (mm)	230
Main platform size (length x width) (mm)	2790×1600	Tire size (diameter x width) (mm)	Φ663×283

Drive system

Item		Specification/Content
Traveling reducer	Rated output torque (N.m)	3500

Hydraulic system

Item		Specification/Content
Function system	Model	
	Open system	
	Pump displacement (ml/r)	
	Lifting system	Max working pressure (Mpa)
	Steering system	Max working pressure (Mpa)
Floating system	Max working pressure (Mpa)	

Electrical System

Item		Specification/Content
Drive motor	Rated Voltage (V)	29
	Rated current (A)	125
	Rated power (kW)	3.56
	Rated speed (r/min)	3400
Lifting motor	Rated Voltage (V)	48
	Rated current (A)	330
	Rated power (kW)	8.9
	Rated speed (r/min)	3290
Battery	Output voltage (V)	6
	Capacity (Ah)	390(20 hours)
Charger	Nominal AC input voltage (V)	85-265 AC
	Maximum AC input current (A)	10
	Nominal DC output voltage (V)	48
	Maximum DC output current (A)	35
Control system	Voltage (V)	24

Oil capacity

Item	Parameter
Hydraulic oil (L)	50
Traveling reducer gear oil(L)	0.68*2

Note: The corresponding hydraulic oil should be selected according to the environment and temperature when adding hydraulic oil. Refer to the following:

Item	Condition	Oil viscosity brand	Remarks
Hydraulic oil	$-25^{\circ}\text{C} < \text{The lowest temperature}$	L-HV 32 low temperature hydraulic oil	Recommended chevron brand
	$-40^{\circ}\text{C} < \text{The lowest temperature} \leq -25^{\circ}\text{C}$	L-HS 32 Ultralow temperature hydraulic oil	
	$\text{The lowest temperature} \leq -40^{\circ}\text{C}$	10# Aviation hydraulic oil	
Driving Reducer oil	$30^{\circ}\text{C} < \text{The lowest}$	85W/140	API GL-5

	temperature		
	-10° C < The lowest temperature < 30° C	85W/90	
	-30° C < The lowest temperature < -10° C	80W/90	
	The lowest temperature < -30° C	75W	

Chapter 5 Control Unit

5.1 Ground Control Unit (GCU)

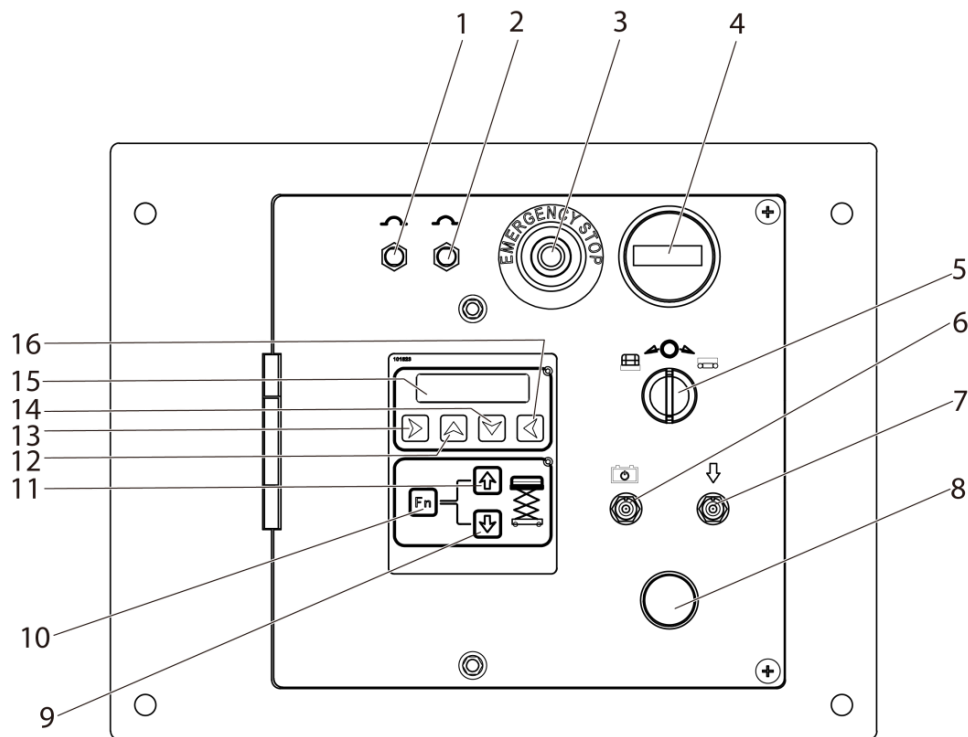

No.	Name	Operation function description
1	Fuse	
2	Fuse	
3	Emergency stop switch	Press the emergency stop switch to stop all functions; pull the emergency stop switch to operate the machine.
4	Timer(if equipped)	The timer displays hours that the machine has been running. The running time of machine can also be displayed by ground controller.
5	Key switch	Turn the key switch to the platform position and the platform control unit will operate; turn the key switch to the neutral position and the machine will stop; turn the key switch to the chassis position and the ground control unit will operate.
6	Function enable button switch for emergency lowering	Press this button to activate emergency lowering
7	Emergency lowering button switch	Press this button to activate emergency lowering
8	Buzzer	
9	Platform lowering button	Press this button to lower the platform
10	Lift function enable button	Press and hold this button to activate the lift function
11	Platform lift button	Press this button to lift the platform

12	Menu up button	
13	Menu exit button	
14	Menu down button	
15	Display	
16	Menu entry button	

5.2 Platform Control Unit (PCU)

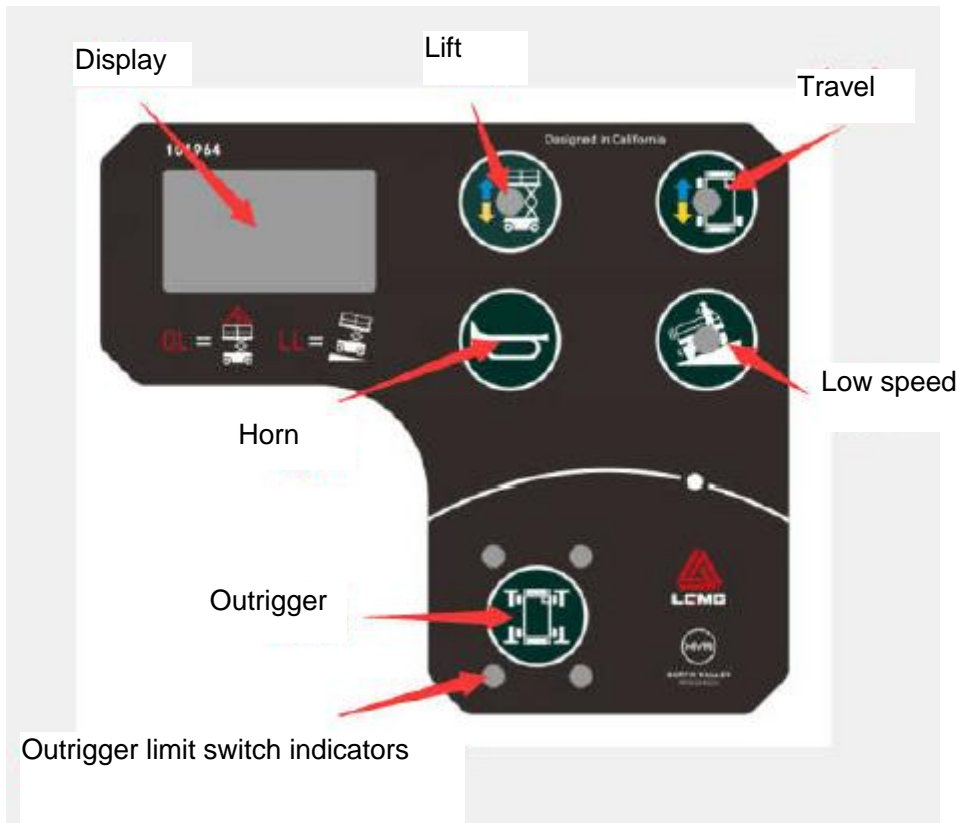

5.3 Basic Operations

Main power source and safety

- 1) The key switch supplies power to the emergency stop switch and the selector switch on the chassis or platform. The power will be cut off when the key switch is in the middle position, and the machine remains in the selected operating mode when the key is removed at any of the three positions.
- 2) Both the chassis and the platform control unit are provided with emergency stop switches, which are connected in series and must be pulled out before normal operation. Pressing any of the emergency stop switches on the chassis or the platform will cut off the power. The safety function is based on a complete circuit, which will be disconnected after pressing any emergency stop switch.
- 3) The enable switch on the handle must be pressed before operating the traveling, steering, Outriggers, lifting or lowering function.

Lifting and safety

- 1) Tilt switch (Built-in Ground control Unit) or The chassis tilt sensor indicates the chassis is either level or not.
- 2) The load may not exceed the rated load of the machine of the model.
- 3) The platform can be lifted or lowered from two positions: on the chassis or on the platform. The key switch is used to select from which position to operate.
- 4) At the chassis position, only the lifting or lowering of the platform can be operated by the ECU button.
- 5) At the platform position, the operator on the platform is allowed to select the lift mode. The lifting/lowering and speed can be controlled by moving the handle. The platform will be lifted when moving the handle forward and will be lowered when moving the handle backward.
- 6) If there is a load sensing option among the

function options, the electronic control unit (ECU) on the chassis will sound and alarm and prohibit the operation when the platform is overloaded.

- 7) If there is a fault in the lifting or lowering valve, an error code will be displayed on the PCU's LED and the ECU's LCD.

Traveling and safety

- 1) Traveling can only be controlled by the handle on the PCU, and the key switch should be set at the platform position.
- 2) If you want the machine to travel, you must select the travel mode and press the enable switch on the handle.
- 3) Move the handle forward or backward to control the travel direction and speed.
- 4) You can select "High speed" or "Low speed" only when the platform is in the retracted state. However, when the platform is in the lifted state (beyond the lower limit), the machine can only work at the "speed after lifting".
- 5) If the platform is overloaded, all actions are prohibited.
- 6) In any non-travel mode, the brake will be disabled.
- 7) If the outrigger function is enabled and any of the outriggers touch the ground, driving is prohibited.

Steering and safety

- 1) The key switch must be set at the platform position.
- 2) Steering can only be controlled by the left and right buttons on the top of the handle on the PCU.
- 3) If you want to turn the machine, you must select the travel mode and press the enable switch on the handle.

Outriggers and outrigger safety

- 1) The key switch must be selected in the platform position.
- 2) The outriggers can only be controlled by the Joystick on the PCU.

- 3) There is an outrigger function in the function options. You must open Outrigger Function to perform outrigger operation. backward, the outrigger will extend or retract.
- 4) There are 4 status lights on the PCU corresponding to the status of the four outriggers. When the light is on, the outriggers touch the ground. When the light is off, the outriggers are retracted. After any outriggers touch the ground, the vehicle is prohibited from driving.
- 5) After turning on the outrigger function, press the outrigger button and enable button of the upper control PCU, push the handle forward to control the outrigger extend, and pull the handle back to control the outrigger recovery. After all of 4 outriggers touch the ground, they will automatically enter the outrigger Leveling mode. After the leveling, the buzzer will sound, indicating that the outrigger leveling is over.
- 6) Outrigger operation must ensure that the platform height is below the lower limit.
- 7) Failure of outrigger solenoid valve can be displayed on PCU and ECU.

Other operations

- 1) When lifting or traveling, the stopwatch on the chassis will work. (If equipped)
- 2) The left two-digit LED on the PCU is used to display the battery status and the right two-digit LED is used to display the system status or error code.

Operation at low battery level

- 1) The battery level status is determined by the operator setting the battery level and the battery level bars are displayed on the PCU.
- 2) Normal traveling will be allowed when there are two or more battery level bars.
- 3) The traveling speed will be decelerated when there is one battery level bar.

Outrigger

Turn the key switch to the upper control mode, press the outrigger buttons, press the enable switch and move the control handle forward or

Operation mode	PCU display	ECU display
Powered on but not moved	Battery level	Ready +Running time Ground Mode+ Battery level
Travel forward or backward	Battery level	Ready + Running time Platform Mode+ Battery level
Lift the platform	Battery level + machine mode code	Machine mode code
Lower the platform	Battery level + software version	Software version
An error occurred	Battery level + error code	Error code
Chassis control mode	CH	Ready + Running time Ground Mode+ Battery level

System troubleshooting and fault code

In the error alarm state, the alarm code will flash once per second on the PCU display.

Table: Alarm code

Display	Description	Machine response
01	System initialization error	Stop all actions
02	System communication error	Stop all actions
03	The machine type is not set for the first use	Stop all actions
04	Machine type setting invalid	Stop all actions
05	BMS communication error	Stop all actions
10	BMS Fault	Show alarm only
12	The chassis up or down button is enabled incorrectly when starting	Stop all chassis controls
13	Limit switch redundancy error	Stop lifting and driving
14	Communication failure with ZAPI controller 1	Stop lifting and driving
15	Communication failure with ZAPI controller 2	Stop lifting and driving
16	Outrigger 1 solenoid coil failure	Stop lifting and driving
17	Outrigger 2 solenoid valve coil failure	Stop lifting and driving
19	Outrigger 3 solenoid valve coil failure	Stop lifting and driving
23	Prompt of stopping walking while lifting	Show alarm only
27	Proportional solenoid valve coil error	Stop lifting and driving
31	Pressure sensor error	Stop all actions
32	Angle sensor error	Stop all actions
33	Outrigger 4 solenoid valve coil failure	Stop lifting and driving
34	Perform emergency drop 1S after overload alarm	Save fault code only
35	No load full load calibration data error	Show alarm only
36	Low-voltage alarm I	low speed walking
40	Communication interruption with GPS	Stop lifting
41	GPS locking fault	Stop lifting

42	The platform left turn button is pressed incorrectly when starting.	Show alarm only
43	The platform right turn button is pressed incorrectly when starting.	Show alarm only
44	ZAPI controller failure	Show fault only
46	The platform handle enable switch button is pressed incorrectly when starting.	Stop platform control
47	The platform handle is not in the neutral position when starting	The speed drops to the speed after lifting
49	Platform leg button pressed incorrectly during startup	Stop platform controls
50	Left bridge floating coil error	Stop lifting and driving
51	Right bridge floating coil error	Stop lifting and driving
52	Forward coil error	Stop lifting and driving
53	Reversing coil error	Stop lifting and driving
54	Lifting up coil error	Stop lifting and driving
56	Right turn coil error	Stop lifting and driving
57	Left turn coil error	Stop lifting and driving
58	Accumulator pressure sensor error	Stop lifting and driving
59	Floating enable coil error	Stop lifting and driving
68	Low-voltage alarm II	low speed walking、stop lifting
80	Above 80% load alarm	Alarm only
90	Above 90% load alarm	Alarm only
93	Horizontal calibration error	Stop all actions
94	Calibration error of angle analog limit switch	Stop all actions
99	Above 99% load alarm	Alarm only
OL	Platform overload alarm	Stop all actions
LL	The machine is tilted beyond the safety limit	Stop lifting and driving

Troubleshooting guidance

Display	description
01	System initialization error: ECU may be faulty, replace ECU
02	System communication error: check the connection of communication lines and other cables. If the fault still cannot be solved, please replace PCU or ECU
03	The machine type is not set for the first use: set the appropriate machine type
04	The selected machine type is not in the scope of application, please choose again according to the model
05	Communication interruption error: check ECU and PCU wiring
12	Wrong pressing of chassis up or down button during startup: Check if the up or down button of the ECU mask is damaged
13	Limit switch redundancy error: check 4 outrigger limit switches and lower limit switches, check switch wiring
14	Communication failure with ZAPI controller 1: check the wiring between ZAPI controller 1 and ECU
15	Communication failure with ZAPI controller 2: check the wiring between ZAPI controller 2 and ECU

16	Outrigger 1 solenoid valve coil failure: Check the coil connections to make sure there are no problems. If there is no problem, check the coil itself for short circuit or open circuit
17	Outrigger 2 solenoid valve coil failure: Check the coil connection to make sure there is no problem If there is no problem, check the coil itself for short circuit or open circuit
19	Outrigger 3 solenoid valve coil failure: Check the coil connection to make sure there is no problem. If there is no problem, check the coil itself for short circuit or open circuit
27	Check that the proportional valve is wired correctly
31	Pressure sensor error: Check the sensor wiring and the sensor itself. You can also check to make sure that the correct machine option with overload detection is selected
32	Angle sensor error: Check the sensor wiring and the sensor itself. You can also check to make sure that the correct machine option with overload detection is selected
33	Outrigger 4 solenoid valve coil failure: Check the coil connection to make sure there is no problem. If there is no problem, check the coil itself for short circuit or open circuit.
34	Perform emergency descending 1S after overload alarm: only record emergency descending action
35	Check the calibration process
42	When starting, the platform left turn button was pressed incorrectly: make sure nothing is holding down the button on the handle. If not, consider replacing the handle or PCU
43	When starting, the platform turn right button was pressed incorrectly: make sure that nothing is holding down the button on the handle. If not, consider replacing the handle or PCU
44	ZAPI controller failure: check ZAPI controller and its wiring
46	When starting, the platform handle enable switch was pressed incorrectly: Make sure that nothing is holding down the enable switch on the handle. If not, consider replacing the handle or PCU
47	When starting, the platform handle is not in the center position error: Make sure the handle is in the center position. Check the median parameter setting. If there is no problem, consider replacing the handle or PCU
49	Platform leg button pressed incorrectly during startup: Make sure that nothing is pressing the button on the handle. If not, consider replacing the handle or PCU
50	Left bridge floating coil error: Check the connection of the coil to make sure there is no problem. If there is no problem, whether the scissor coil itself is short-circuited or open-circuited
51	Right bridge floating coil error: Check the coil connection to make sure there is no problem. If there is no problem, check the coil itself for short circuit or open circuit
54	Lifting coil error: Check the connection of the coil to make sure there is no problem. If there is no problem, check the coil itself for short circuit or open circuit
56	Right turn coil error: Check the connection of the coil to make sure there is no problem. If there is no problem, check the coil itself for short circuit or open circuit
57	Left turn coil error: Check the connection of the coil to make sure there is no problem. If there is no problem, check the coil itself for short circuit or open circuit
58	Accumulator pressure sensor error: Check the sensor wiring and the sensor itself
59	Floating enable coil error: Confirm that there is no problem. If there is no problem, check the coil itself for short circuit or open circuit
68	Low voltage alarm: check whether the vehicle voltage is too low and whether it needs to be charged
80	More than 80% load alarm: The load limit is approaching on the platform. Consider not increasing the load
90	Over 90% load alarm: The load limit is approaching on the platform. Consider not increasing the load
93	Horizontal calibration error: horizontal calibration by key
99	Over 99% load alarm: The load limit has been reached on the platform. Do not increase the load
OL	Platform overload error: Remove excessive load immediately

LL	Machine tilt exceeds safety limit error: If the machine is tilted, find a way to bring it back to level. If the machine is level, check the wiring of the level sensor or the sensor itself
----	---

Chapter 6 Pre-operation Inspection

6.1 No Operation will be Allowed Before

- 1) You have understood and practiced the principles of safe operation of the machine in this manual.
- 2) Avoid dangerous situations.
- 3) Always perform a pre-operation inspection.
- 4) You should understand pre-operation inspection before proceeding with the next step.
- 5) Inspect the workplace.
- 6) Always perform pre-operation functional tests.
- 7) Use the machine only for the design purpose.

6.2 Basic Principles

- 1) It is the operator's responsibility to perform pre-operation inspection and routine maintenance.
- 2) Pre-operation inspection is a very intuitive process that is performed by the operator before each shift. The purpose of the inspection is to determine if there is a significant problem with the machine before the operator performs a functional test.
- 3) Pre-operation inspection can also be used to determine if a routine maintenance procedure is necessary. The operator can only perform the routine maintenance items specified in this manual.
- 4) See the checklist on the next page and check each item and position for any parts change, damage, looseness or missing.
- 5) Machines that have been damaged or modified may not be used. In the event of any damage or any unauthorized changes different from the normal status, the machine should be marked and prohibited from putting into operation.
- 6) Only qualified service technicians are allowed to maintain the machine according to the manufacturer's instructions. After the maintenance is completed, the operator

must perform a pre-operation inspection again before continuing the functional test.

- 7) Regular maintenance inspections should be performed by qualified service technicians according to the manufacturer's specifications and the requirements listed in the responsibilities manual.

6.3 Pre-operation Inspection

- 1) Make sure the manual is complete, easy to read, and stored in a file box on the platform.
- 2) Make sure all labels are clear, legible, and in the right place. See the label section.
- 3) Check hydraulic oil for leakage and appropriate oil level. Please fill the oil as needed. See the "Maintenance" section.
- 4) Check the battery fluid for leakage and appropriate liquid level. Add the distilled water as needed. See the "Maintenance" section
- 5) Check the following parts or areas for damage, improper installation, parts missing or unauthorized changes:
 - Electrical components, wires and cables
 - Hydraulic hoses, joints, valve blocks, hydraulic cylinders
 - Drive motor
 - Wear pad
 - Tire and wheel
 - Limit switch, alarm and horn
 - Nuts, bolts and other fasteners
 - Platform extension
 - Platform entry port
 - Indicators and alarms
 - Safety arm
 - Pins and fasteners
 - Platform control handle
 - Outrigger cover and foot pad
- 6) Check the entire machine for:
 - Crack in the weld or structural member

- Dent or damage to the machine
- Make sure all structural members and other critical components are complete, and all associated fasteners and pins are in the right position and tightened
- The fence has been installed, the fence bolts are in place and the bolts are properly tightened.



CAUTION: If the platform must be lifted to check the machine, make sure the safety arm is in the right position. See the "Operating Instruction" section.

Chapter 7 Workplace Check

7.1 No Operation, Except Following Cases

- 1) You have known and practiced the rules for safe operation of machine in the Operation Manual.
- 2) Avoid the dangers.
- 3) Always check before operation.
- 4) Check the work place.
- 5) Know and understand the workplace check and then perform the next operation.
- 6) Always perform the function test before operation.
- 7) Use the machine only as per the design intent of the machine.

7.2 Basic Principles

- 1) The workplace check helps operators determine whether the workplace ensures safe operation of machine. The operator shall carry out the work before moving the machine to the workplace.
- 2) Knowing and remembering the hazards in the workplace is the responsibility of the operator, who can be aware of and avoid them when moving, installing, and operating machines.

7.3 Workplace Check

Beware and avoid the following dangerous situations.

- 1) Steep slopes or caves.
- 2) Protrusions, ground obstacles or debris.
- 3) Declining surface.
- 4) Unstable or smooth surface.
- 5) Aerial obstacles and high voltage lines.
- 6) Hazardous area.
- 7) Surface support insufficient to withstand the full load applied by the machine.
- 8) Wind and weather conditions.
- 9) There are unauthorized personnel.
- 10) Other possible unsafe conditions.

Chapter 8 Functional Test

8.1 No Operation will be Allowed Before

- 1) You have understood and practiced the principles of safe operation of the machine in this manual.
- 2) Avoid dangerous situations.
- 3) Always perform pre-operation checks.
- 4) Inspect the workplace.
- 5) Always perform pre-operation functional tests.
- 6) You should understand the functional test and inspection before proceeding with the next step.
- 7) Use the machine only for the design purpose.

8.2 Basic Principles

- 1) Functional tests are used to detect faults before operating the machine. The operator must follow the steps to test all the functions of the machine.
- 2) Do not use a malfunctioning machine. If a fault is found, the machine must be marked and stopped.
- 3) Only qualified service technicians are allowed to maintain the machine according to the manufacturer's instructions.
- 4) After the maintenance is completed, the operator must perform the pre-operation inspection and functional test again before operating the machine.

8.3 Functional Test

- 1) Choose a test place that is solid, level and free of obstacles. Make sure the battery has been connected.

8.4 On the Ground Control Unit

- 1) Pull the red emergency stop button on the platform and ground to the "ON" position.
- 2) Turn the key switch to the ground control unit.

- 3) Observe the LCD display window on the ground control unit.

Result: The LCD screen will light up and the operator interface will be displayed.

Test the emergency stop function

- 1) Push the ground red emergency stop button inward to the "OFF" position.

Result: The machine will be stopped and all functions will not work.

- 2) Pull the red emergency stop button to the "ON" position.

Test the lifting/lowering function

The audible alarms on the machine and the standard horn are from the same central alarm. The horn will send a continuous sound. The lowering alarm will sound 60 times per minute. The alarm that sounds when the machine is tilted sounds 180 times per minute.

- 1) Do not press the lifting function enable button. Press and hold the platform lifting or lowering button.

Result: The platform should not be lifted or lowered.

- 2) Do not press the platform lifting or lowering button.
- 3) Press the lifting function enable button.

Result: The lifting function should not be operated.

- 4) Press and hold the lifting function enable button and press the platform lifting button.

Result: The platform should be lifted.

- 5) Press and hold the lift function enable button and press the platform lowering button.

Result: The platform should be lowered. The lowering alarm should sound when the platform is lowered.

Test the emergency lowering function

- 1) Press and hold the lift function enable button while lifting the platform by approximately 60 cm.
- 2) Push the ground red "Emergency Stop"

button inward to the "OFF" position.

- 3) Pull the red "Emergency Stop" button to the "ON" position.
- 4) Turn the key switch to the platform controller operation mode.
- 5) Move and hold the emergency lowering function enable button switch.
- 6) Move and hold the emergency lowering button switch.

Result: The platform should be lowered. The lowering alarm will not sound.

8.5 Test on the platform control unit

Test the emergency stop function

- 1) Push the platform red "Emergency Stop" button to the "OFF" position.

Result: The machine should be stopped and all functions will not work.

- 2) Pull out the red "Emergency Stop" button to the "ON" position.

Result: The platform control unit should display the operator interface and can work normally.

Test the horn

- 1) Press the horn button.
- 2) Result: The horn will sound.

Test the traveling function enable button

- 1) Do not press the traveling function enable button on the control handle.
- 2) Slowly move the control handle in the direction indicated by the blue arrow and slowly move the control handle in the direction indicated by the yellow arrow.

Result: All functions will not work.

Test the lifting/lowering function and enable the function

- 1) In the direction indicated by the blue and yellow arrows, activate the up/down rocker switch.

Result: The platform should not be lifted or lowered.

- 2) Press the lifting function enable button.

- 3) Press and hold the enable switch on the control handle.
- 4) Activate the lifting/lowering rocker switch in the direction indicated by the blue arrow.

Result: The platform should be lifted and the lifting alarm should sound.

- 5) Press the lifting function enable button.
- 6) Press and hold the enable switch on the control handle.
- 7) Press and hold the direction indicated by the yellow arrow to activate the lifting/lowering rocker switch.

Result: The platform should be lowered. When the platform is lowered, the lowering alarm should sound.

Test the steering function



CAUTION: When performing the

steering and drive function tests, stand in the middle of the platform and face the steering end of the machine.

- 1) Press the driving function enable button.
- 2) Press and hold the enable switch on the control handle.
- 3) Press the thumb rocker switch on the top of the control handle in the direction indicated by the blue triangle on the control panel.

Result: The steering wheel should be turned in the direction indicated by the blue triangle on the control panel.

- 4) Press the thumb rocker switch in the direction indicated by the yellow triangle on the control panel.

Result: The steering wheel should be rotated in the direction indicated by the yellow triangle on the control panel.

Test the drive and brake functions

- 1) Press the driving function enable button.
- 2) Press and hold the enable switch on the control handle.

- 3) Slowly move the control handle in the direction indicated by the blue arrow on the control panel until the machine begins to move, and then reset the handle to the center position.

Result: The machine should move in the direction indicated by the blue arrow on the control panel and then stop suddenly.

- 4) Press and hold the enable switch on the control handle.
- 5) Slowly move the control handle in the direction indicated by the yellow arrow on the control panel until the machine begins to move, and then reset the handle to the center position.

Result: The machine should move in the direction indicated by the yellow arrow on the control panel and then stop suddenly.



CAUTION: The brake must be able to stop the machine stably at any slope the machine can climb.

Test the lifting drive speed

- 1) Raise the platform to a height of approximately 2.4 m from the ground.
- 2) Press the driving function enable button.
- 3) Press and hold the enable switch on the control handle.
- 4) Slowly move the control handle to the fully driven position.

Result: The maximum drive speed that can be achieved when the platform is lifted should not exceed 0.5 km/h.

If the maximum drive speed exceeds when the platform is lifted, mark the machine immediately and stop it.

8.6 Test the tilt sensor operation



CAUTION: This test should be performed on the ground with the

platform control unit. Do not stand in the platform.

- 1) Fully lower the platform.
- 2) Place a 2x4(in) or similar piece of wood under both wheels on one side and drive the machine up onto them.
- 3) Raise the platform to a certain height.
- 4) The platform should stop and the tilt alarm will sound at 180 beeps per minute. The platform controls LED readout should display LL and the ground controls LCD should display LL. (Machine Tilted)
- 5) Press the drive function button.
- 6) Press and hold the function enable switch on the control handle.
- 7) Move the control handle in the direction indicated by the blue arrow, then move the control handle in the direction indicated by the yellow arrow.

Result: The drive function should not work in either direction.

- 8) Lower the platform and remove both pieces of wood.

Chapter 9 Operation Instruction

9.1 No Operation will be Allowed Before

You have understood and practiced the principles of safe operation of the machine in this manual.

- 1) Avoid dangerous situations.
- 2) Always perform pre-operation checks
- 3) Inspect the workplace.
- 4) Always perform pre-operation functional tests.
- 5) Use the machine only for the design purpose.

9.2 Basic Principles

- 1) This machine is an electric drive lifting device that is equipped with a working platform on the scissor mechanism. The vibration generated when the machine is working will not be dangerous to the operator who is standing on the work platform. This machine can be used to load workers and their portable tools to a certain height from the ground, or to reach a certain working area above the machine or equipment.
- 2) The “Operating Instruction” section provides specific instructions for all aspects of machine operation. It is the operator’s responsibility to follow all safety rules and instructions in the Operation and Maintenance Manual.
- 3) In addition to lifting personnel and tools to the overhead workplace, it is unsafe or even dangerous to use this machine for other purposes.

 **CAUTION: This machine is**

strictly prohibited from carrying goods.

- 4) Only trained and authorized personnel can operate the machine. If more than one operators use the same machine at different times during the same work shift, they must be qualified operators and follow

all safety rules and instructions in the Operation and Maintenance Manual. This means that every new operator should perform pre-operation inspections, functional tests and workplace inspections before operating the machine.

9.3 Emergency Stop

- 1) On the ground control unit or platform control unit, push the red emergency stop button to the “OFF” position to stop all functions.
- 2) The function should be fixed if it is still working when any of the red emergency stop buttons is pressed.

9.4 Emergency Lowering

- 1) On the ground control unit, turn the key switch to the Platform control unit.
- 2) Make sure the ground and platform red “Emergency Stop” buttons are pulled out to the “ON” position.
- 3) Move and hold the emergency lowering function enable button switch.
- 4) Move and hold the emergency lowering button switch.

9.5 Operation on the Ground

- 1) Make sure the battery is connected before operating the machine.
- 2) Turn the key switch to the ground control unit.
- 3) Pull the red “Emergency Stop” buttons on the ground and platform to the “ON” position.

Adjust the platform position

- 4) Press and hold the lifting function enable button.
- 5) Press the platform up or down button.

The drive and steering functions are not available through the ground control unit.

9.6 Operation on the Platform

- 1) Make sure the battery is connected before operating the machine and turn the key

switch to the platform control unit.

- 2) Pull out the red "Emergency Stop" buttons on the ground and platform to the "ON" position.

Adjust the platform position

- 1) Press the lift function enable button.
- 2) Press and hold the enable switch on the control handle.
- 3) Move the control handle in the desired direction.

Turn

- 1) Press the drive function enable button.
- 2) Press and hold the enable switch on the control handle.
- 3) Turn the steering wheel with the thumb rocker switch located on the top of the control handle.

Drive mode

- 1) Press the drive function enable button.
- 2) Press and hold the enable switch on the control handle.
- 3) Increase the speed: Slowly move the control handle away from the center position.

Reduce the speed: Slowly move the control handle to point to the center position.

Stop: Return the control handle to the center position or release the function enable switch.

Determine the direction in which the machine will move using the platform control unit and the directional arrow on the platform.

When the platform is lifted, the speed of the machine will be limited.



The battery condition will affect the machine performance. When the battery indicator flashes, the drive speed and function speed of the machine will decrease.

Drive speed selector switch

Symbol when the machine is on a slope:
Operate in a low speed range when tilting.

9.7 Driving on a Slope

Determine the machine's ratings of the slope and side slope. The slope rating applies to the machine in the stowed state.

Item	SR1018E SR1218E SR1418E	SR0818E
 Maximum slope rating in the retracted state	35%(19 °)	40%(22 °)
 Maximum side slope rating in the retracted state	35%(19 °)	40%(22 °)

⚠ CAUTION: The slope rating is limited by the ground conditions and traction.

- 1) Determine the slope: Measure the slope with a digital inclinometer or follow the steps below.
- 2) Required tools: carpentry's ruler, straight block with a length of at least 1m, tape measure
- 3) Place the block on the slope and place the carpentry's ruler on the upper edge of the block at the end of the downhill slope and raise the end of the block until it is level. Keep the block level and measure the vertical distance from the bottom of the block to the ground. Divide the tape measure distance (the raised height) by the block length (travel) and multiply by 100 to get the slope value.

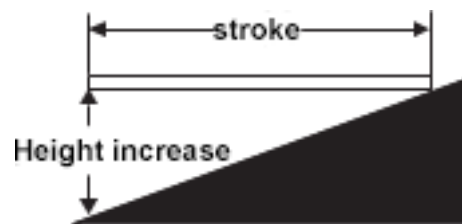

- 4) If the slope exceeds the maximum uphill, downhill or side slope rating, the machine

must be lifted or transported up and down the slope. See the "Transportation and Lifting" section.

9.8 Operation on the Ground Using the Platform Control Unit

- 1) Maintain a safe distance between the operator, the machine and the stationary object.
- 2) When operating the control unit, pay attention to the travel direction of the machine.

9.9 Extending and Retracting of the Platform

- 1) Lift the platform extension lock handle to the horizontal position.
- 2) Push the platform extension lock handle to extend the platform to the desired position.

Do not stand on the extension platform when trying to extend the platform.

- 3) Press the platform extension lock handle to engage the upper and lower teeth to lock the extension platform.

9.10 How to Operate the Safety Arm

- 1) Lift the platform to a height of about 3.2 m from the ground.
- 2) Lift the safety arm and move it to the middle of the scissor shaft bushing and rotate it up to the vertical status.
- 3) Lower the platform until the safety arm is in full contact with the shaft sleeve.

9.11 Auxiliary Descent

When unable to lower the platform normally due to a fault, pull the cable assembly that is located at the rear of the machine outward.

Result: The platform will lower.

9.12 Fall Protection

Personal Fall Protection Equipment (PFPE) is not required to operate this machine. If PFPE is required in the workplace or employer rules, the following rules apply:

All PFPEs must comply with the appropriate government regulations and must be inspected and used according to the manufacturer's instructions.

9.13 Instructions for Battery and Charger

Keep in mind the followings:

- 1) Do not use an external charger or a booster battery.
- 2) Charge the battery in a well-ventilated area.
- 3) Charge the battery using the correct AC input voltage indicated on the charger.

Charge the battery

- 1) Make sure the battery is connected before charging.
- 2) Open the battery compartment cover. The compartment cover should remain open throughout the charging process.

Maintenance-free batteries

- 1) Connect the battery charger to a grounded AC circuit.
- 2) The charger will give an indication when the battery is fully charged.

Standard Batteries

- 1) Remove the battery vent cap and check the battery acid level. If necessary, only add the distilled water necessary for covering the plate. Do not add excessive distilled water before charging.
- 2) Reset the battery vent cap.
- 3) Connect the battery charger to a grounded AC circuit.
- 4) The charger will give an indication when the battery is fully charged.
- 5) Check the battery acid level at the end of the charge cycle. Add the distilled water to the bottom of the filling pipe. Do not add excessive distilled water.

Instructions for dry battery filling and charging

- 1) Remove the battery vent cap and permanently remove the plastic seal from the battery vent.
- 2) Fill the battery acid till the indication level of every unit can be over the plate.
- 3) Do not fill to the maximum level until the battery charging process is completed. Excessive filling may cause the battery acid to overflow during charging. Sodium hydrogen carbonate and water can be used to neutralize the overflowed battery acid.
- 4) Install the battery vent cap.
- 5) Charge the battery.
- 6) Check the battery acid level at the end of the charge cycle. Add the distilled water to the bottom of the filling pipe. Do not add excessive distilled water.

9.14 After Each Use

- 1) Choose a safe parking position, which can be a solid level surface, without obstacles and heavy traffic.
- 2) Lower the platform.
- 3) Turn the key switch to the "OFF" position and remove the key to avoid unauthorized use.
- 4) Charge the battery.
- 5) Cut off the power when the machine is repaired or not used for long period.

Chapter 10 Instructions for Transportation and Lifting

10.1 Compliance

- 1) When the machine is lifted by a crane or forklift, maintain normal judgment and planning to control the movement of the machine.
- 2) Only personnel with high-altitude lifting qualifications can load and unload the machine.
- 3) The transport vehicle must be parked on a level surface.
- 4) When loading the machine, the transport vehicle must be fixed to prevent movement.
- 5) Make sure the vehicle's capacity, loading surface, chain or belt is sufficient to withstand the weight of the machine. Please see the "Specification" for the weight of the machine.
- 6) The machine must be parked on a level surface or fixed before releasing the brake.
- 7) Do not drive the machine on slopes that exceeds the uphill, downhill or side slope rating. See the "Driving on a Slope" in the "Operating Instructions".
- 8) If the slope of the transport vehicle exceeds the maximum slope rating, the winch must be used to load and unload the machine as described in "Brake Release Operation".
- 9) Prevent the guide rail from falling when removing the latch. Always hold the guide rail when folding it.

10.2 Freewheel Configuration

for Trailers

- 1) Wedge the wheel to prevent the vehicle from moving.

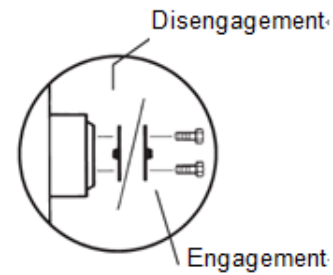

- 2) Turn over all four driving wheel hub separating covers to release wheel brakes. Make sure that the winch cable is properly secured to the fastening point of the drive chassis and that there are no obstacles in the moving direction.
- 3) Reverse the above procedures to reengage the brakes.
- 4) Wedge the wheel to prevent the vehicle from moving.

Key release-(If equipped)



Before release the brake, the main power supply should be connected, and the emergency stop switch on the chassis and platform must be cut off.

- 1) Chock wheels to prevent machine from rolling.
- 2) Be sure winch line is properly secured to drive chassis tie points and path is clear of all obstructions.
- 3) Turn the key switch to one side to release the brake.

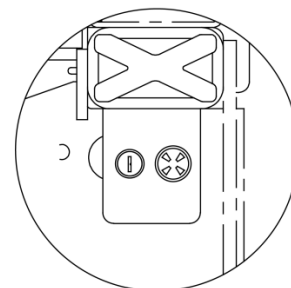

After brake release operation:

- 1) Chock wheels to prevent machine from rolling.
- 2) Turn the key switch to the off position to engage the brake.

10.3 Fixed to a Truck or Trailer during Transportation

- 1) The machine wheels must always be blocked when preparing for transport.
- 2) Secure the machine to the transport surface with the tie points on the chassis.
- 3) Use at least 4 chains or belts. Make sure the chain or belt used has sufficient load strength.
- 4) Turn the key switch to the "OFF" position and remove the key before transporting.

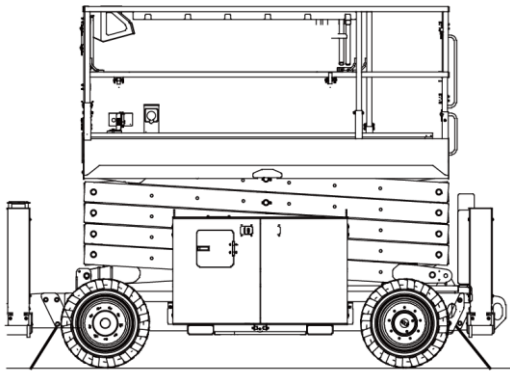
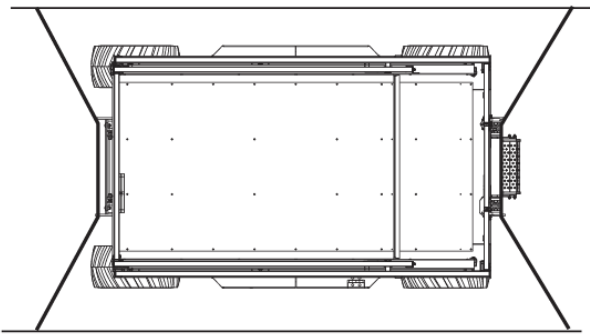

10.4 Ensure the Transportation Safety

- 1) The machine wheels must always be locked when preparing for transport.
- 2) Retract and fix the extension platform.
- 3) Before transporting, turn the key switch to the "OFF" position and remove the key.
- 4) Thoroughly inspect the machine to prevent loose or unsecured parts.

- 5) Secure the machine to the transport surface with the tie points on the chassis.
- 6) Use at least four chains or belts.
- 7) Make sure the chain or belt used has sufficient load strength.
- 8) If the platform guide rail has been folded, secure it with a belt before transporting.

Compliance

- 1) Only qualified hook operators can assemble the lock and lift the machine.
- 2) Make sure the crane's lifting capacity, loading surface, belt or rope is sufficient to withstand the weight of the machine. Please see the serial number plate.

10.5 Guidance for Lifting

- 1) Lower the platform completely. Make sure that the extension platform, control unit and chassis tray are fixed securely. Remove all moving parts from the machine.
- 2) Only connect the lock to the specified lifting point on the machine.
- 3) Adjust the lock to avoid damaging the machine and keeping the machine level.

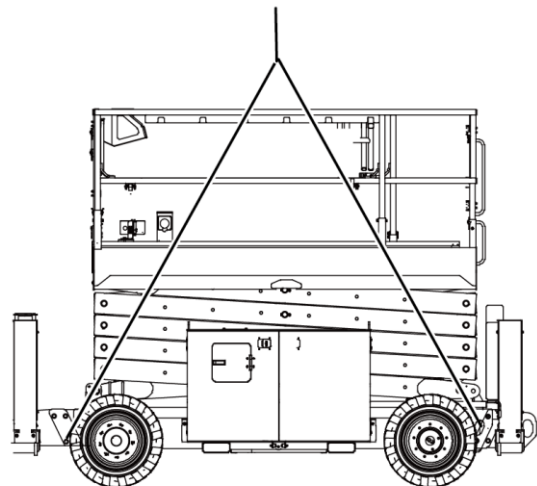

Other ManualsLib Projects



www.manualslib.com



www.manualslib.de



www.manualslib.es



www.manualslib.fr



www.manualslib.nl



www.manualslib.mx



www.manualslib.tech 30+ Languages