



OPERATING MANUAL (ANSI/CSA)

# TELESCOPIC BOOMS

MODELS **SJ40T** **SJ45T** **SJ61T** **SJ66T**

207518AEA November 2018

**SKYJACK**<sup>TM</sup>

**This manual is based on Serial Number(s):**

SJ40T SJ45T 98 001 767 & Above  
SJ61T SJ66T 97 001 833 & Above

Please refer to the website ([www.skyjack.com](http://www.skyjack.com)) for older Serial Numbers.

**Skyjack Service Center**

3451 Swenson Ave. St. Charles,  
Illinois, 60174 USA  
Phone: 630-262-0005  
Toll Free: 1-800-275-9522  
Fax: 630-262-0006  
Email: [service@skyjack.com](mailto:service@skyjack.com)

**Parts (North America)**

Toll Free: 1-800-965-4626  
Toll Free Fax: 1-888-782-4825  
E-mail: [parts@skyjack.com](mailto:parts@skyjack.com)

**Skyjack Australia Pty Ltd.**

Unit 1, 35 Honeycomb Drive  
Eastern Creek  
New South Wales 2766  
Australia  
Tel: +61 (0) 2 9854 0700  
Fax: +61 (0) 2 9854 0777

**Parts & Service (Europe)**

Unit 1 Maes Y Clawdd  
Maesbury Road Industrial Estate  
Oswestry, Shropshire SY10 8NN UK  
Phone: +44-1691-676-235  
Fax: +44-1691-676-238  
E-mail: [info@skyjackeurope.co.uk](mailto:info@skyjackeurope.co.uk)

**Skyjack Brasil**

Alameda Júpiter, 710  
Loteamento American Park Empresarial  
Indaiatuba, SP, Brasil 13347-653  
Tel: +55 19 3936 0132

---

The Safety Alert Symbol identifies important safety messages on aerial platform, safety signs in manuals or elsewhere. When you see this symbol, be alert to the possibility of personal injury or death. Follow the instructions in the safety message.



**This Safety Alert Symbol means attention!**

**Become alert! Your safety is involved.**



**DANGER**

**DANGER indicates an imminently hazardous situation which, if not avoided, will result in death or serious injury.**



**WARNING**

**WARNING indicates a potentially hazardous situation which, if not avoided, could result in death or serious injury.**



**CAUTION**

**CAUTION indicates a potentially hazardous situation which, if not avoided, may result in minor or moderate injury. It may also be used to alert against unsafe practices.**

**IMPORTANT**

**IMPORTANT indicates a procedure essential for safe operation and which, if not followed, may result in a malfunction or damage to the aerial platform.**

---

## Table of Contents

<b>Section 1 - About Your Aerial Platform</b> .....	<b>5</b>
Read and Heed .....	5
Safety Rules.....	6
<b>Section 2 - Familiarization</b> .....	<b>13</b>
2.1 Familiarization of Telescopic Boom Series .....	13
2.2 Component Identification .....	14
2.3 Visual & Daily Maintenance Inspections .....	21
2.4 Function Tests.....	29
2.5 Winching and Towing Procedure .....	39
2.6 Emergency Lowering Procedures.....	41
<b>Section 3 - Operation</b> .....	<b>43</b>
3.1 General .....	43
3.2 Major Components.....	44
3.3 Major Assemblies .....	45
3.4 Serial Number Nameplate .....	45
3.5 Component Identification .....	46
3.6 Component Identification (Optional Equipment/Attachments).....	47
3.7 Operator's Responsibility .....	50
3.8 Start Operation .....	51
3.9 Refueling Procedure.....	58
3.10 Loading/Unloading .....	59
3.11 Chassis Tilt.....	62
<b>Section 3 - Diagrams</b> .....	<b>63</b>
<b>Section 4 - Tables</b> .....	<b>69</b>
Table 4.1 Standard and Optional Features .....	69
Table 4.2a Specifications and Features .....	70
Table 4.2b Specifications and Features .....	71
Table 4.3 Owner's Annual Inspection Record.....	72
Table 4.4 Maximum Platform Capacities.....	72
Table 4.5 Tire/Wheel Specifications .....	73
Table 4.6 Floor Loading Pressure .....	74
Table 4.7 Maintenance and Inspection Schedule.....	75
Table 4.8 Operator's Checklist .....	76
<b>Section 5 - Labels</b> .....	<b>77</b>
<b>Section 6 - Skyjack Features</b> .....	<b>103</b>

SKYJACK is continuously improving and expanding product features on its equipment, therefore, specifications and dimensions are subject to change without notice.

### Aerial Platform Definition

A mobile device that has an adjustable position platform supported from ground level by a structure.

### Purpose of Equipment

The SKYJACK Telescopic Boom Series (Models SJ 40T, SJ 45T, 61T & 66T) aerial platform is designed to transport and raise personnel, tools and materials to overhead work areas.

### Use of Equipment

The aerial platform is a highly maneuverable, mobile work station. Work platform elevation and elevated driving must only be done on a firm, level surface. It can be driven over uneven terrain only when the platform is fully lowered.

### Manual

The operating manual is considered a fundamental part of the aerial platform. It is a very important way to communicate necessary safety information to users and operators. A complete and legible copy of this manual must be kept in the provided weather-resistant storage compartment on the aerial platform at all times.

### Operator

The operator must read and completely understand both this operating manual and the safety panel label located on the platform and all other warnings in this manual and on the aerial platform. Compare the labels on the aerial platform with the labels found within this manual. If any labels are damaged or missing, replace them immediately.

### Service Policy and Warranty

SKYJACK warrants each new SJT series work platform to be free of defective parts and workmanship for the first 24 months. Any defective part will be replaced or repaired by your local SKYJACK dealer at no charge for parts or labor. Contact SKYJACK Service Department for warranty statement extensions or exclusions.

### Optional Accessories

The SKYJACK aerial platform is designed to accept a variety of optional accessories. These are listed under “Standard and Optional Features” in [Table 4.1](#). Operating instructions for these options (if equipped) are located in [Section 3](#) of this manual.

For non-standard components or systems, contact the SKYJACK Service Department at:

☎ : 800 275-9522

☎ : 630 262-0006

Include the model and serial number for each applicable aerial platform.

### Scope of this Manual

a. **This manual applies** to the ANSI/SIA and CSA versions of the Telescopic Boom aerial platform models listed on [Table 4.1](#).

- **Equipment identified** with “ANSI” meets the ANSI/SIA A92.5-2006 standard.
- **Equipment identified** with “CSA” meets the CSA B354.4-02 standard.

b. **CSA (Canada)**

Operators are required to conform to national, territorial/provincial and local health and safety regulations applicable to the operation of this aerial platform.

c. **ANSI/SIA (United States)**

Operators are required by the current ANSI/SIA A92.5 standards to read and understand their responsibilities in the manual of responsibilities before they use or operate this aerial platform.

**WARNING**

**Failure to comply with your required responsibilities in the use and operation of the aerial platform could result in death or serious injury!**

**Operator Safety Reminders**

A study conducted by St. Paul Travelers showed that most accidents are caused by the failure of the operator to follow simple and fundamental safety rules and precautions.

You, as a careful operator, are the best insurance against an accident. Therefore, proper usage of this aerial platform is mandatory. The following pages of this manual should be read and understood completely before operating the aerial platform.

Common sense dictates the use of protective clothing when working on or near machinery. Use appropriate safety devices to protect your eyes, ears, hands, feet and body.

Any modifications from the original design are strictly forbidden without written permission from SKYJACK.

**Electrocution Hazard**

This aerial platform is not electrically insulated. Maintain a Minimum Safe Approach Distance (MSAD) from energized power lines and parts as listed below. The operator must allow for the platform to sway, rock or sag. This aerial platform does not provide protection from contact with or proximity to an electrically charged conductor.

Per ANSI A92.5-2006 8.10(7)

“The operator shall perform only the work for which he or she is qualified, in compliance with all applicable safety related work practices intended to prevent electric shock covered by the Code of Federal Regulations (CFR) 1910.333. The operator’s level of competence shall be established only by persons qualified to do so. Operators shall maintain the appropriate minimum approach distance (**MAD**) from energized power lines and parts covered by CFR 1910.333 (c).”

Unqualified persons must maintain a minimum approach distance of 10 feet from any energized power line up to 50 kV. Energized power lines over 50 kV require a greater minimum approach distance to be maintained. Refer to CFR 1910.333.

As per CSA B354.4-02

“The operator shall maintain the minimum safe approach distance (**MSAD**) from energized conductors at all times in accordance with the authority having jurisdiction.”

Refer to CFR 1910.333 or the authority having jurisdiction.

**DO NOT USE AERIAL PLATFORM AS A GROUND FOR WELDING.  
DO NOT OPERATE AERIAL PLATFORM DURING LIGHTNING OR STORMS.  
DO NOT OPERATE THE AERIAL PLATFORM NEAR POWER LINES. MAINTAIN A MINIMUM SAFE APPROACH DISTANCE (MSAD) FROM ENERGIZED POWER LINES.**

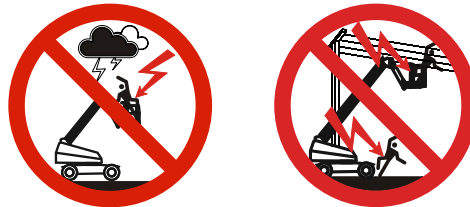

 <b>DANGER</b> Avoid Power Lines	
<b>Minimum Safe Approach Distance</b>	
ANSI/SIA A92.6-2006 & CSA B354.2-01 Requirements	
Voltage Range (Phase to Phase)	Minimum Safe Approach Distance (Feet)
0 to 300V	Avoid Contact
Over 300V to 50KV	10
Over 50KV to 200KV	15
Over 200KV to 350KV	20
Over 350KV to 500KV	25
Over 500KV to 750KV	35
Over 750KV to 1000KV	45
<b>FAILURE TO AVOID THIS HAZARD WILL RESULT IN DEATH OR SERIOUS INJURY!</b>	

60023AD-ANSI

Safety Precautions

Know and understand the safety precautions before going on to next section.



**WARNING**

Failure to heed the following safety precautions could result in tip over, falling, crushing, or other hazards leading to death or serious injury.

- **KNOW** all national, state or territorial/provincial and local rules which apply to your aerial platform and jobsite.
- **TURN** main power disconnect switch “O” off when leaving the aerial platform unattended. Remove the key to prevent unauthorized use of the aerial platform.
- **WEAR** all the protective clothing and personal safety devices issued to you or called for by job conditions.

- **DO NOT** wear loose clothing, dangling neckties, scarves, rings, wristwatches or other jewelry while operating this aerial platform .



- **AVOID** entanglement with ropes, cords or hoses.



- **AVOID** falling. Stay within the boundaries of the guardrails. Maintain firm footing on the platform floor at all times while working thereon.



- **ENSURE** all occupants wear personal fall protection equipment.

- **DO NOT** raise the platform in windy or gusty conditions.



- **DO NOT** increase the lateral surface area of the platform. Increasing the area exposed to the wind will decrease aerial platform stability. Avoid tenting.



- **DO NOT** elevate the aerial platform if it is not on a firm, level surface.

- **DO NOT** drive elevated near depressions or holes of any type, loading docks, debris, drop-offs and surfaces that may affect the stability of the aerial platform.



- **DO NOT** elevate or drive elevated on a slope. Elevated driving must be done on a firm, level surface.



- **If operation in areas with holes or drop-offs is absolutely necessary**, elevated driving shall not be allowed. Position the aerial platform horizontally only with the platform fully lowered. After ensuring that all 4 wheels or outriggers (if equipped) have contact with a firm, level surface, the aerial platform can be elevated. After elevation, the drive function must not be activated.



- **DO NOT** drive elevated on a soft or uneven surface.



- **DO NOT** ascend or descend a grade steeper than 50% (2WD & 4WD). Boom elevated driving must only be done on firm level surfaces.



Safety Precautions (Continued)

Know and understand the safety precautions before going on to next section.

- **DO NOT** operate an aerial platform that has ladders, scaffolding or other devices mounted on it to increase its size or work height. It is prohibited.



- **BE AWARE** of blind spots when operating the aerial platform.



- **DO NOT** exert side forces on aerial platform while elevated.



- **ENSURE** that there are no personnel or obstructions in the path of travel, including blind spots.



- **DO NOT** use the aerial platform as a crane. It is prohibited.



- **DO NOT** lower the platform unless the area below is clear of personnel and obstructions.



- **DO NOT** climb on boom arm assembly. It is prohibited.



- **DO NOT** use boom to push, pull other objects or to lift the chassis.



- **DO NOT** sit, stand or climb on the guardrails. It is prohibited.



- **DO NOT** raise the aerial platform while it is on a truck, forklift or other device or vehicle.



- **AVOID** overhead obstructions. Be aware of overhead obstructions or other possible hazards around aerial platform when lifting or driving.



- **STUNT** driving and horseplay are prohibited.



- **DO NOT** use with improperly inflated/damaged tires or wheels. Refer to [Section 2: Wheel/Tire Assembly](#).



- **AVOID** crushing hazards. Be aware of crushing hazards when lifting or driving. Keep all body parts inside the aerial platform.



- **DO NOT** alter or disable limit switches or other safety devices.

- **DO NOT** use the aerial platform without guardrails, locking pins and the entry gate in place.

Safety Precautions (Continued)

Know and understand the safety precautions before going on to next section.

- **DO NOT** exceed the rated capacity of the aerial platform.

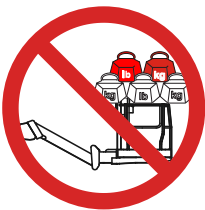

- **DO NOT** position the aerial platform against another object to steady the platform.

- **DO NOT** place materials on the guardrails or materials that exceed the confines of the guardrails unless approved by Skyjack.

- **DO NOT** distribute load unevenly.

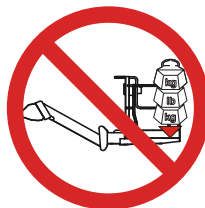

- **DO NOT** operate if aerial platform is not working properly or if any parts are damaged or worn.



- **DO NOT** use under influence of alcohol or drugs.



- **DO NOT** leave aerial platform unattended with key in key switch.



- **DO NOT** attempt to free a snagged platform with lower controls until personnel are removed from the platform.

### Safety Precautions (Continued)

Know and understand the safety precautions before going on to next section.

#### Fall Protection

All occupants of this aerial platform must wear personal fall protection equipment.



#### **WARNING**

**Failure to wear personal fall protection equipment may result in death or serious injury.**

As per the ANSI A92.5-2006 standard, “Principal fall protection is provided by the guardrail system. The user shall direct and monitor the operator to ensure that all components of the guardrail system are in place. The user shall direct and monitor the occupants of the work platform to ensure that they wear a personal fall arrest system to protect against the potential effects of ejection or a fall restraint system to prevent a free fall.”

Fall restraint and fall arrest systems are defined within the ANSI A92.5 Manual of Responsibilities shipped with this aerial platform.

Skyjack recommends the use of a fall restraint system to keep an occupant within the confines of the platform, and thus not expose the occupant to any fall hazard requiring a fall arrest.

CSA B354.4-02 requires the use of a fall arrest system, therefore Canadian users must use personal fall arrest protection as opposed to fall restraint.

All personal fall protection equipment must comply with applicable governmental regulations and must be inspected and used in accordance with the manufacturer’s recommendations.

All personal fall protection equipment must be attached only to approved anchorage points within the platform of the aerial platform.



#### **WARNING**

**Entering and exiting the aerial platform should only be done using the three points of contact.**

- Use only equipped access openings.
- Enter and exit only when the aerial platform is in the fully retracted position.
- Do use three points of contact to enter and exit the platform. Enter and exit the platform from the ground only. Face the aerial platform when entering or exiting the platform.
- Three points of contact means that two hands and one foot or one hand and two feet are in contact with the aerial platform or the ground at all times during entering and exiting.



#### **WARNING**

**An operator should not use any aerial platform that:**

- does not appear to be working properly.
- has been damaged or appears to have worn or missing parts.
- has alterations or modifications not approved by the manufacturer.
- has safety devices which have been altered or disabled.
- has been tagged or locked out for non-use or repair.

**Failure to avoid these hazards could result in death or serious injury.**

#### Jobsite Inspection

- Do not use in hazardous locations.
- Perform a thorough jobsite inspection prior to operating the aerial platform, to identify potential hazards in your work area.
- Be aware of moving equipment in the area. Take appropriate actions to avoid collision.



2.1 Familiarization of Telescopic Boom Series



**WARNING**

**Aerial Platform Familiarization should be given only to individuals who are QUALIFIED And TRAINED to operate an aerial platform.**

**Do not operate this aerial platform without proper authorization and training. Failure to avoid this hazard could result in death or serious injury.**

**It is the responsibility of the operator to read, completely understand and follow all instructions and warnings contained in this operating manual and on the aerial platform.**

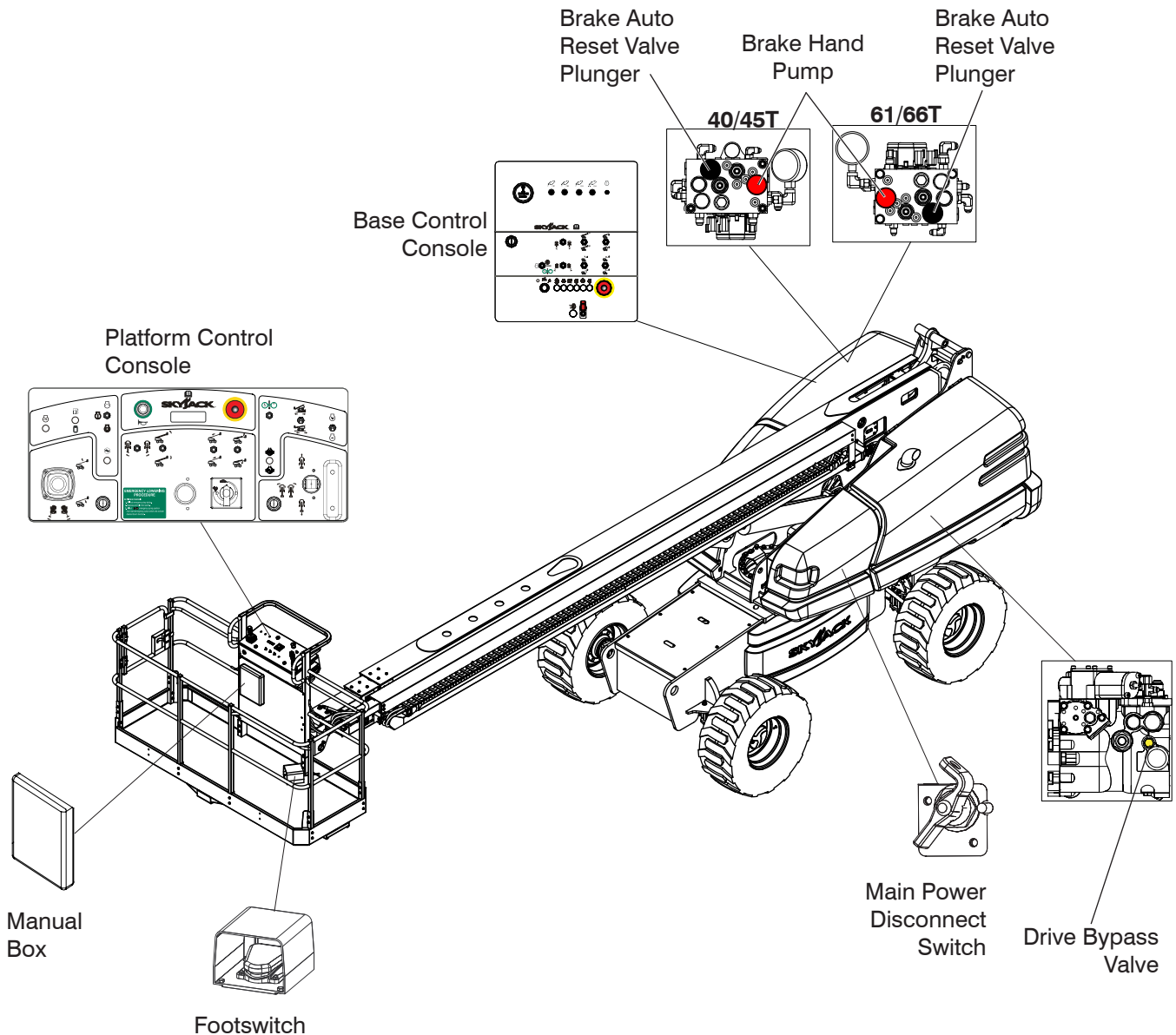

FAMILIARIZATION

## 2.2 Component Identification

The following descriptions are for identification, explanation and locating purposes only.

### 2.2-1 Drive Bypass Valve

This valve is located on the inboard side of the drive pump and can be identified with a yellow paint mark on it.

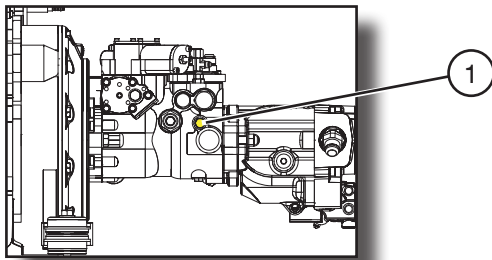

Figure 2-1. Drive Bypass Valve

#### 1. Drive Bypass Valve with Override Stems

- This valve, when loosened two revolutions counterclockwise, is used to override drive relief valves so that the aerial platform can be loaded or unloaded from a trailer using a winch line.

### 2.2-2 Main Power Disconnect Switch

This switch is located in the engine compartment near the battery.

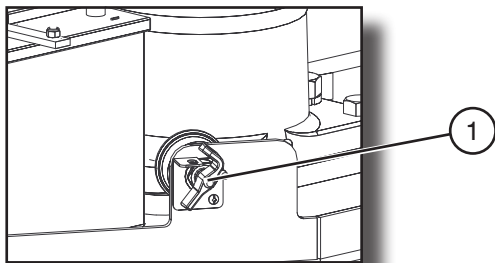

Figure 2-2. Main Power Disconnect Switch

1. **Main Power Disconnect Switch** - This switch, when in “○” off position, disconnects power to all circuits. Switch must be in “I” on position to operate any circuit. Turn switch “○” off when transporting aerial platform.

### 2.2-3 Brake System

The brake system is located in the control compartment. The brakes must be manually disengaged before pushing, winching or towing. Refer to [Section 2.5-1](#) for procedure on how to release brakes manually. The system contains the following controls:

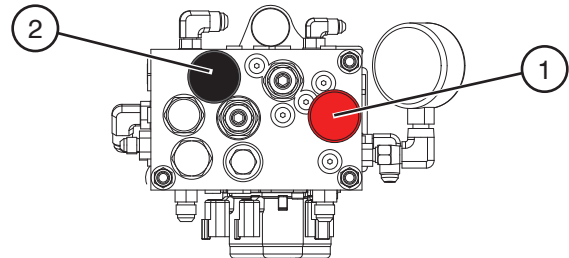

Figure 2-3a. Brake System - SJ40/45T

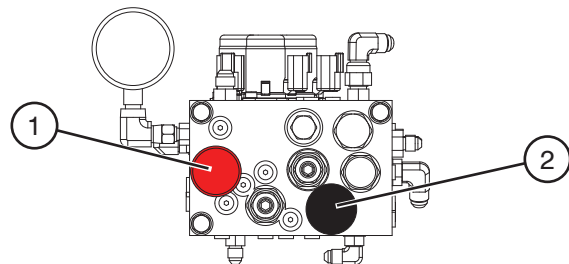

Figure 2-3b. Brake System - SJ61/66T

1. Brake Hand Pump
2. Brake Auto Reset Valve Plunger

### 2.2-4 Tilt Switch

The tilt switch is located on top of the base control console. It is designed to prevent driving when aerial platform is on a slope greater than a predetermined limit.



#### **WARNING**

**If aerial platform becomes tilted causing alarm to sound, the platform must be fully lowered immediately. Ensure that aerial platform is on a firm level surface before operating the aerial platform. Refer to Section 3.11 for instructions regarding recovery from an inclined position.**

### 2.2-5 Differential Lock Switch

This switch is located on the platform control console. The differential locking system provides more traction by providing equal drive to each wheel regardless of traction. Differential locks are used to prevent from getting stuck when driving on loose, muddy, or rocky terrain. Refer to Section 2.4-3 for instruction regarding testing differential lock switch.



#### **WARNING**

**Before engaging differential lock, ensure drive/steer controller is in neutral position.**

### 2.2-6 Footswitch

The footswitch is located on the floor of the platform. When depressed and held, it enables controls on platform control console.

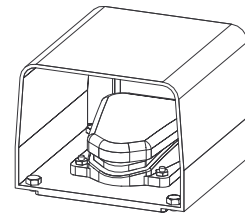

Figure 2-4. Footswitch

#### **NOTE**

The footswitch is equipped with a 15-second anti-tiedown feature that deactivates footswitch when operator depresses it for 15 seconds without activating any function.

2.2-7 Base Control Console

This control console is located in the panel mounted in the control compartment.

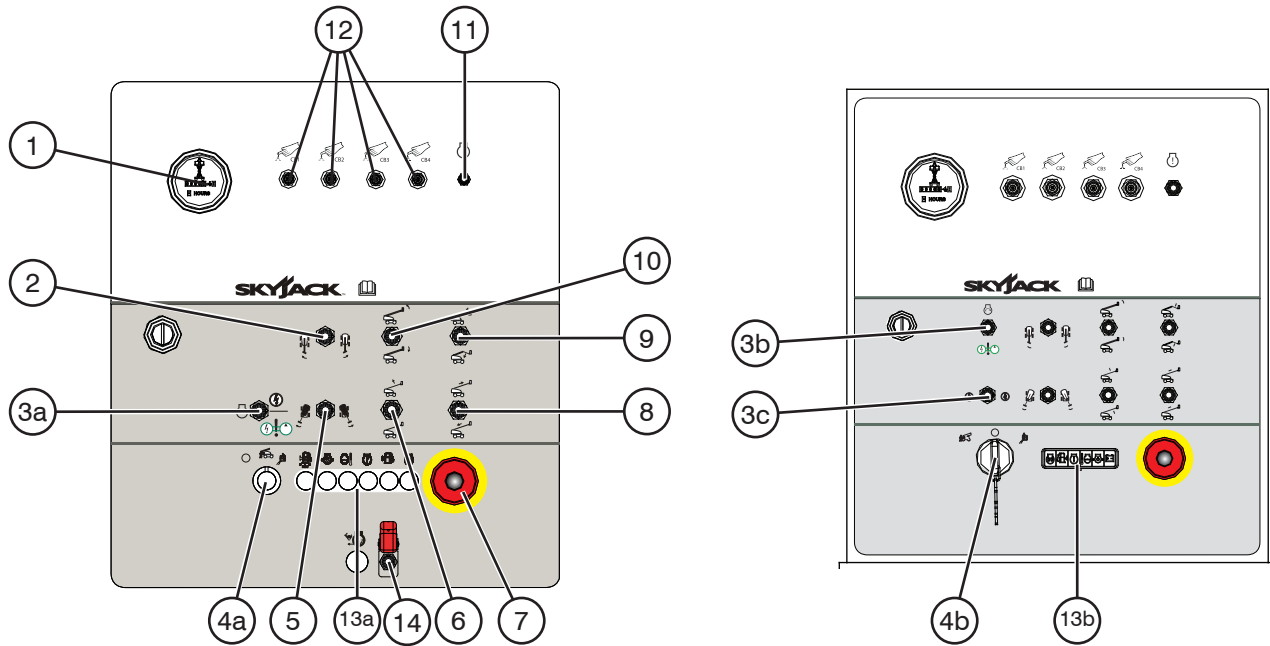

Figure 2-5. Base Control Console

1. **Hourmeter** - This gauge records accumulated operating time of engine.
2. **Platform Rotation Switch** - This switch controls left or right rotation of platform.
- 3a. **Start/Function Enable/Emergency Power Switch** - This momentary switch, when held in start position, starts engine. When held in function enable position, allows base control functions to operate. Engine speed increases when selected. With engine off, and when held in emergency power unit position, allows base control functions to operate using emergency power unit.
- b. **Start/Emergency Power Switch** - This switch starts engine or enables emergency power unit.
- c. **Function Enable Switch** - When held in either direction, this momentary switch allows base control functions to operate.
- 4a. **Off/Base/Platform Key Switch** - This three-way selector switch allows operator to turn off power to aerial platform or to activate either base or platform control console.
- b. **Base/Off/Platform Key Switch** - This three-way selector switch allows operator to turn off power to aerial platform or to activate either base or platform control console.
5. **Turret Rotation Switch** - This switch controls left or right rotation of turret.
6. **Main Boom Raise/Lower Switch** - This switch controls raising or lowering of main boom.
7. **Emergency Stop Button** - This red "mushroom-head" pushbutton disconnects power to control circuit and shuts engine off.

2.2-7 Base Control Console (Continued)

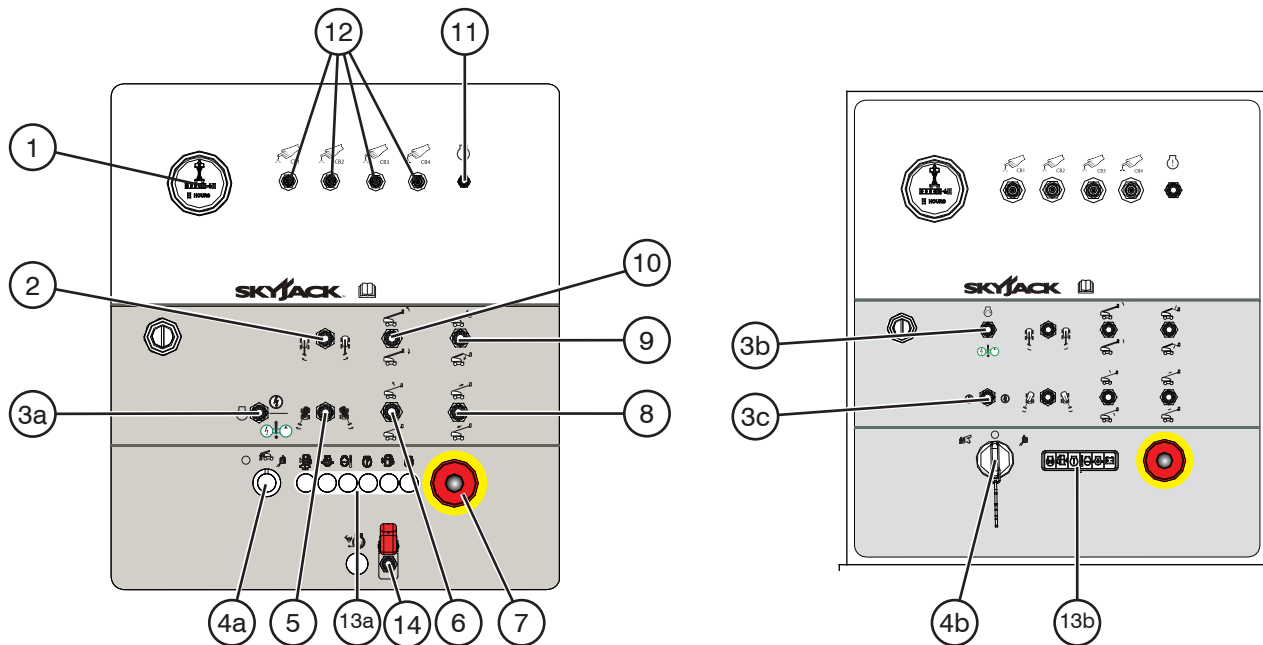
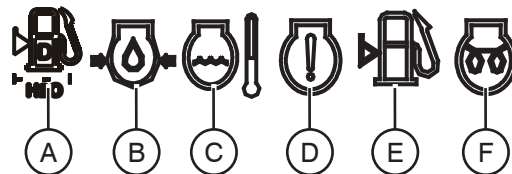

Figure 2-5. Base Control Console

- 8. **Fly Boom Extend/Retract Switch** - This switch controls “” extension or “” retraction of fly boom.
- 9. **Jib Up/Down Switch (If Equipped)** - This switch controls “” up or “” down movement of jib.
- 10. **Platform Leveling Override Switch** - This switch overrides automatic leveling of platform and controls “” tilting up or “” tilting down of platform.
- 11. **Engine Diagnosis Switch** - When held in either direction, this switch “” enables an error blink code for engine control unit (ECU).
- 12. **Circuit Breakers** - In the event of a power overload or positive circuit grounding, the circuit breaker pops out. Push breaker back in to reset.

- 13a. **Status Indicator Pilot Lights** - These lights indicate operational status and errors in any function in the controls/engine.



- A. **Water In Fuel Light** - This light indicates water separator is full. Open drain to release water. Engine damage could occur if ignored for excessive length of time.
- B. **Engine Oil Pressure** - This light indicates low engine oil pressure.
- C. **Engine Coolant Temperature/Level** - This light indicates overheating of engine coolant and low level of engine coolant.
- D. **Engine** - This light indicates failure in engine control system.
- E. **Fuel** - This light indicates low fuel level.
- F. **Glow Plug (Diesel)** - This light illuminates until glow plugs have completed their timed cycle. When the lamp goes out, the engine is ready to be started.

2.2-7 Base Control Console (Continued)

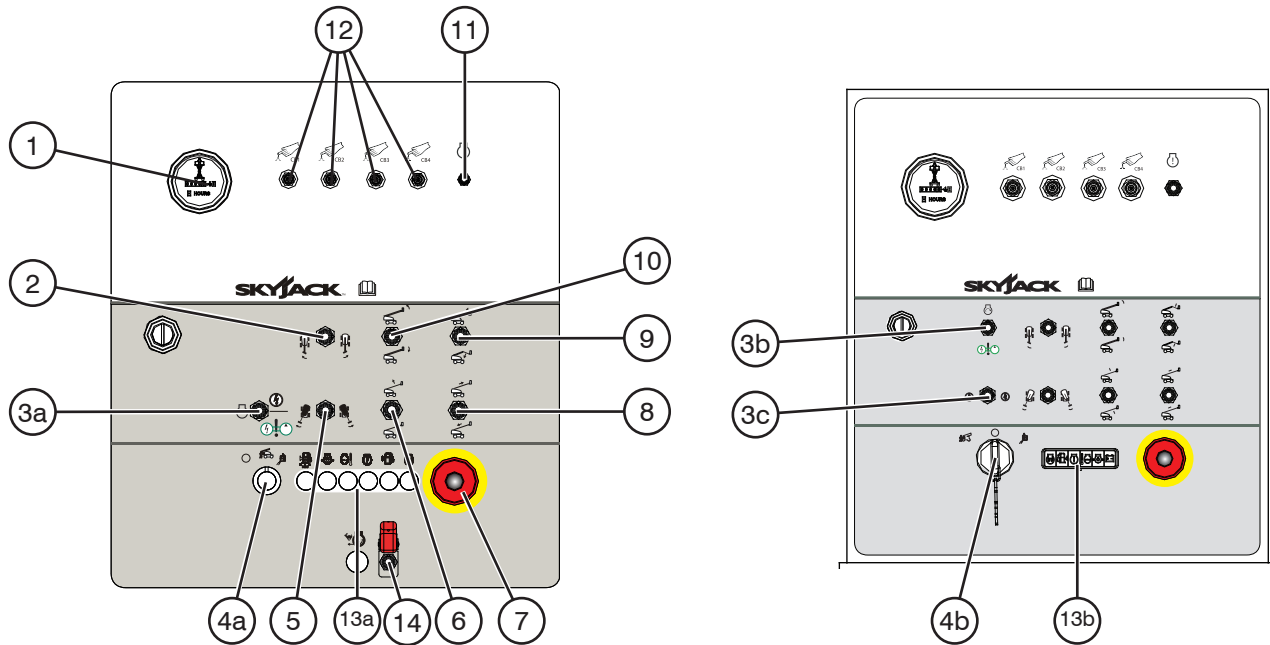
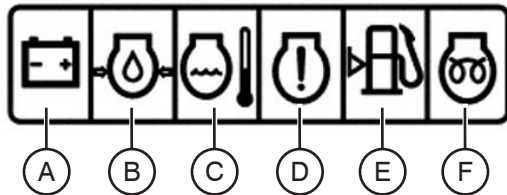

Figure 2-5. Base Control Console

**13b. Status Indicator Pilot Lights** - These lights indicate operational status and errors in any function in the controls/engine.

**14. Positive Air Shutoff Switch (If Equipped)** - This switch allows the operator to shut off the air supply to the engine if the engine continues running after the main power is shut down.



- A. Charging Circuit** - This light indicates charger circuit malfunction.
- B. Engine Oil Pressure** - This light indicates low engine oil pressure.
- C. Engine Coolant** - This light indicates overheating of engine coolant.
- D. Engine** - This light indicates failure in engine control system.
- E. Fuel** - This light indicates low fuel level.
- F. Glow Plug (Diesel)** - This light illuminates until glow plugs have completed their timed cycle. When the lamp goes out, the engine is ready to be started.

2.2-8 Platform Control Console

This control console is mounted at front guardrail of the platform. It has the following controls:

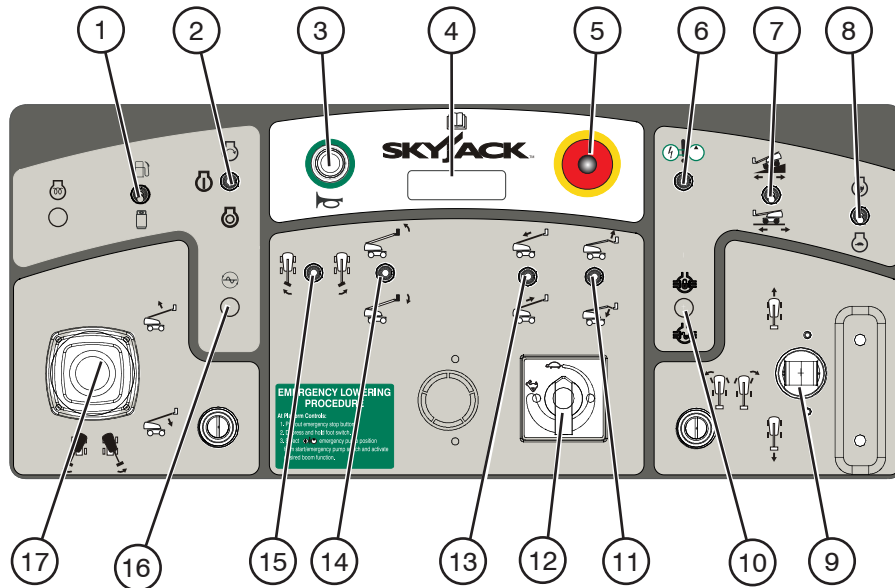
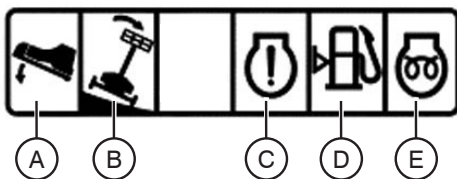

Figure 2-6. Platform Control Console

- 1. **Dual Fuel Switch (If Equipped)** - This switch selects between “” gasoline or “” liquid propane gas.
- 2. **Engine Start/On/Off Switch** - This switch, when held momentarily in “” start position, starts engine. Once started, the switch returns to “” on position. When in “” off position, it turns engine off.
- 3. **Horn Pushbutton** - This “” pushbutton sounds an automotive-type horn.
- 4. **Status Indicator Pilot Lights** - These lights indicate operational status and errors in any function in the controls/engine.
  - B. **Chassis Tilt** - This light illuminates when the aerial platform chassis is at an inclination that activates the tilt sensor. At this inclination, an audible alarm will sound at the platform. Refer to [Section 3.11](#) for instructions regarding recovery from an inclined position.
  - C. **Engine** - This light indicates failure in engine control system.
  - D. **Fuel** - This light indicates low fuel level.
  - E. **Glow Plug (Diesel)** - This light illuminates until glow plugs have completed their timed cycle. When the lamp goes out, the engine is ready to be started.
- 5. **Emergency Stop Button** - This red “mushroom-head” “” pushbutton disconnects power to control circuit and shuts engine off.
- 6. **Emergency Power Unit** - This switch “” enables emergency power unit.
- 7. **Torque Switch** - This switch selects “” low or “” high torque. Select “” low torque (higher speed) or “” high torque (lower speed). Select “” high torque when driving on a slope.



- A. **Footswitch** - This light illuminates when footswitch is depressed. A 15-second anti-tiedown feature deactivates footswitch when operator depresses it for 15 seconds without activating any function.

## 2.2-8 Platform Control Console (Continued)

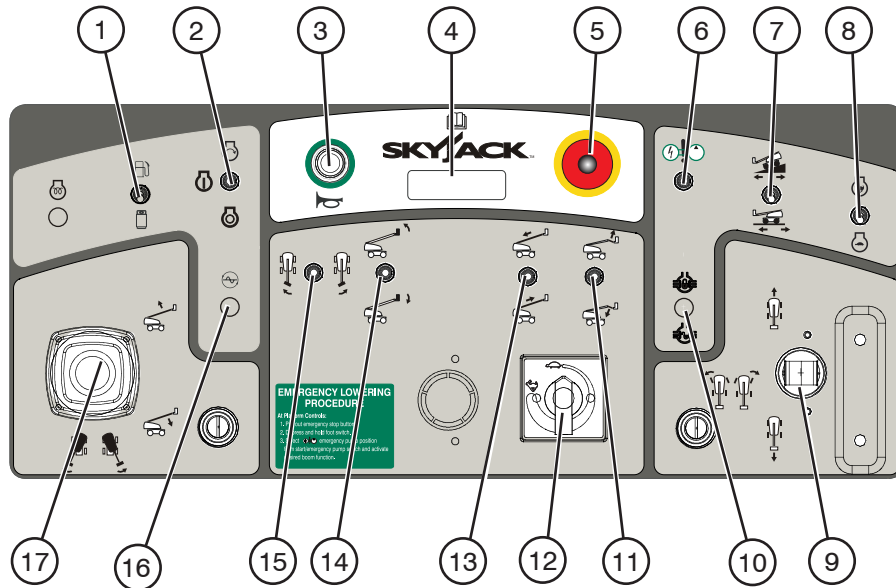











Figure 2-6. Platform Control Console

**8. Low/High Throttle Switch** - This switch allows selection between “” low and “” high engine throttle speeds.



**9. Drive/Steer Controller** - This single-axis lever controls driving “” forward or “” backward.



The rocker switch controls steering “” left or “” right. Internal springs return it to neutral when stick is released.



**10. Differential Lock Switch** - This momentary switch, when pushed forward and then released, engages “” differential lock and turns differential light on. When pulled backward and then released, disengages “” differential lock and turns differential light off.



**11. Jib Up/Down Switch** - This switch controls “” up or “” down movement of jib.





**12. Function Speed Adjuster Dial** - This variable-speed adjuster “” controls speed of fly boom extension/retraction, jib raising/lowering and platform rotation movements. This is used with switches 10, 12 and 14.

**13. Fly Boom Extend/Retract Switch** - This switch controls “” extension or “” retraction of fly boom.

**14. Platform Leveling Override Switch** - This switch overrides automatic leveling of platform and controls “” tilting up or “” tilting down of platform.

**15. Platform Rotation Switch** - This switch controls “” left or “” right rotation of platform.

**16. Generator On/Off Switch (If Equipped)** - This switch turns the hydraulic generator “” on or “” off.

**17. Boom/Turret Controller** - This dual-axis lever controls “” raising or “” lowering of main boom or rotating “” left or “” right of turret

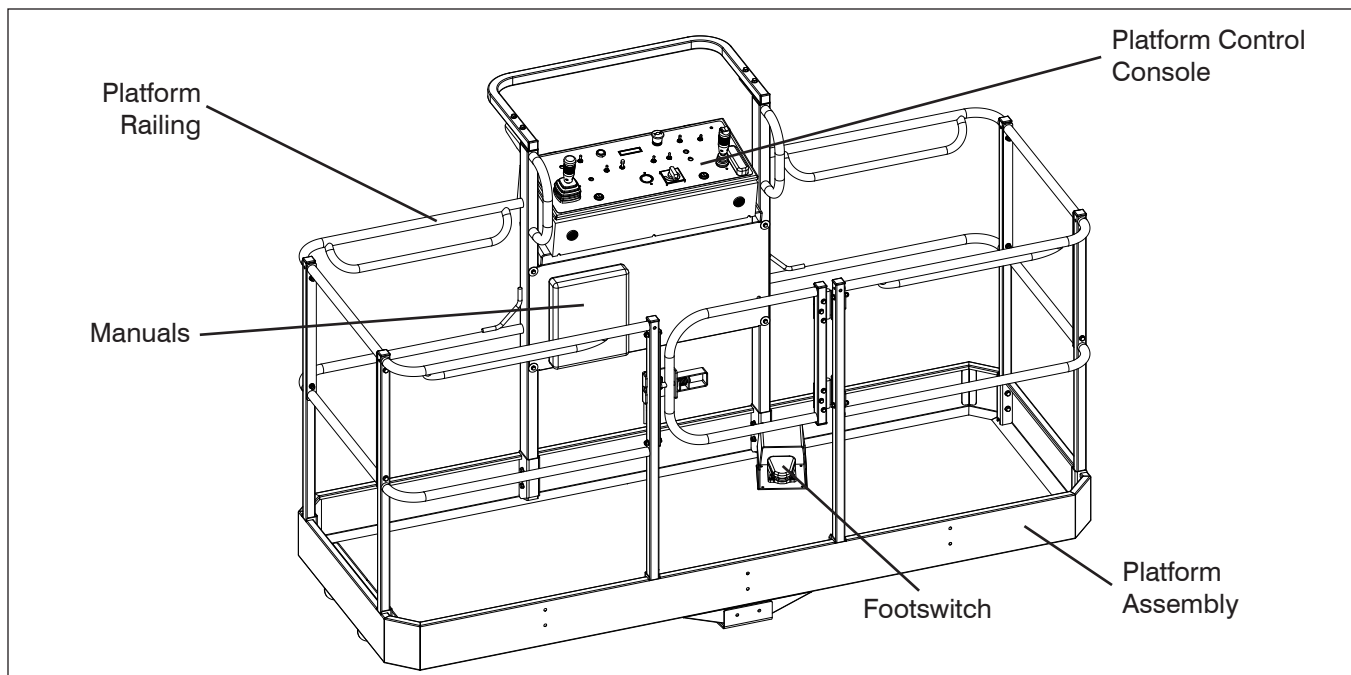

### 2.3 Visual & Daily Maintenance Inspections

Begin the visual and daily maintenance inspections by checking each item in sequence for the conditions listed in this section.



#### **WARNING**

**To avoid injury, do not operate an aerial platform until all malfunctions have been corrected.**



#### **WARNING**

**To avoid possible injury, ensure aerial platform power is off during your visual and daily maintenance inspections.**

#### **NOTE**

While doing visual and daily inspections in different areas, be aware to also inspect limit switches, electrical and hydraulic components.

#### 2.3-1 Labels

Refer to [Section 5 - Labels](#) in this manual and determine that all labels are in place and are legible.

#### 2.3-2 Electrical

Maintaining the electrical components is essential to good performance and service life of the aerial platform.

Inspect the following areas for chafed, corroded and loose wires:

- boom to platform cable harness
- engine compartment electrical panel
- engine wiring harness
- rotary manifold wiring

#### 2.3-3 Limit Switches

Ensure limit switches are properly secured with no signs of visible damage and movement is not obstructed.

#### 2.3-4 Hydraulic

Maintaining the hydraulic components is essential to good performance and service life of the aerial platform.

Perform a visual inspection around the following areas:

- hydraulic tank filter, fittings, hoses, emergency power unit and turret/base surface
- engine compartment fittings, hoses, main pump, filter and turret/base surface
- all hydraulic cylinders
- all hydraulic manifolds
- the underside of the turret
- the underside of the base
- ground area under the aerial platform

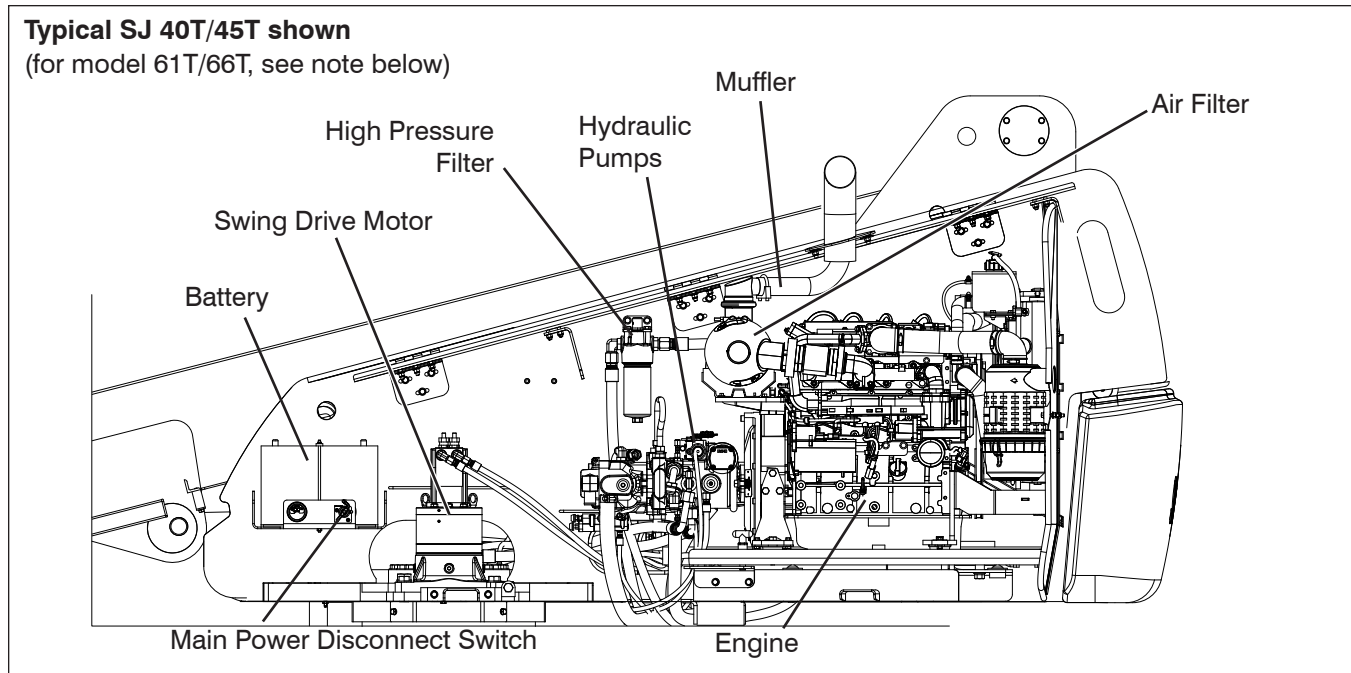

**2.3-5 Engine Compartment**

- Ensure all compartment latches are secure and in proper working order.
- **Main Power Disconnect Switch**  
(see right side for 61T/66T)
  - Turn main power disconnect switch to “○” off position.
  - Ensure there are no loose or missing parts and there is no visible damage.
  - Ensure all cables are secure and switch is in proper working condition.

- **Battery**  
Proper battery condition is essential to good engine performance and operational safety. Improper fluid levels or damaged cables and connections can result in engine component damage and hazardous conditions.

1. Check battery case for damage.
2. Clean battery terminals and cable ends thoroughly with a terminal cleaning tool or wire brush.
3. Ensure all battery connections are tight.
4. If applicable, check battery fluid level. If plates are not covered by at least 1/2” (13 mm) of solution, add distilled or demineralized water.
5. Replace battery if damaged or incapable of holding a lasting charge.



**WARNING**  
Use original or manufacturer-approved parts and components for the aerial platform.



**WARNING**  
Explosion hazard. Keep flames and sparks away. Do not smoke near batteries.



**WARNING**  
Battery acid is extremely corrosive - Wear proper eye and facial protection as well as appropriate protective clothing. If contact occurs, immediately flush with cold water and seek medical attention.

- **Swing Drive Motor**
  - Ensure there are no loose or missing parts and there is no visible damage.
  - Ensure all bolts are properly tightened.
  - Ensure all fittings and hoses are properly tightened and there is no evidence of hydraulic leakage.

**Typical SJ 40T/45T shown**  
(for model 61T/66T, see note below)

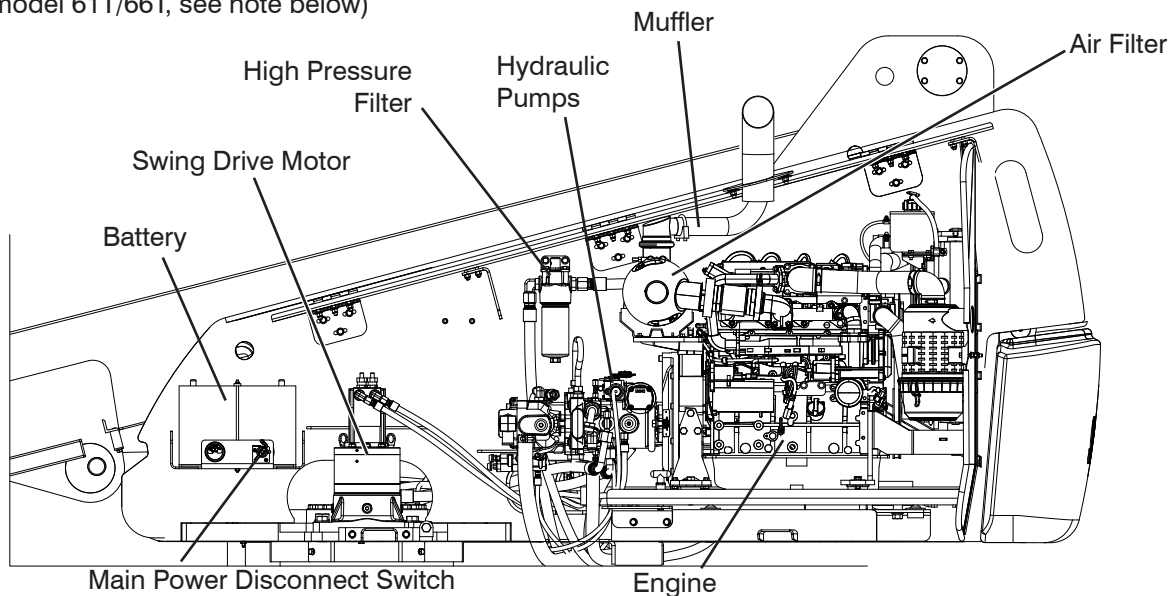

- **Turret Rotation Gear**
    - Ensure there are no loose or missing parts and there is no visible damage.
  - **Rotary Manifold**
    - Ensure all hoses are properly tightened and there is no evidence of hydraulic leakage.
  - **High Pressure Filter (40T/45T)**  
(see Control Compartment for 61T/66T)
    - Ensure housing is secure and shows no visible damage or leakage.
  - **Hydraulic Pumps**
    - Ensure there are no loose or missing parts and there is no visible damage.
    - Ensure all bolts are properly tightened.
    - Ensure all fittings and hoses are properly tightened and there is no evidence of hydraulic leakage.
  - **Muffler and Exhaust**
    - Ensure muffler and exhaust system are properly secured, with no evidence of damage.
  - **Engine Pivot Tray**
    - Ensure there are no loose or missing parts and no visible damage to the engine pivot tray. Ensure that each tray-securing bolt is in place.
  - **Engine Oil Level**
    - Maintaining the engine components is essential to good performance and service life of the aerial platform.
- ⚠ WARNING**  
**Beware of hot engine components.**
- Check oil level on dipstick**
- Oil level should be in the “safe” zone. Add oil as needed. Refer to [Table 4.2b](#) for recommended oil type.
- **Engine Air Filter**
    - Ensure there are no loose or missing parts and there is no visible damage.
  - **Fuel Leaks**
    - Ensure that there no fuel leaks.
- ⚠ DANGER**  
**Engine fuels are combustible. Inspect the aerial platform in an open, well-ventilated area away from heaters, sparks and flames. Always have an approved fire extinguisher within easy reach.**
- Ensure fuel tank, shutoff valve, hoses and fittings show no visible damage and no evidence of fuel leakage.

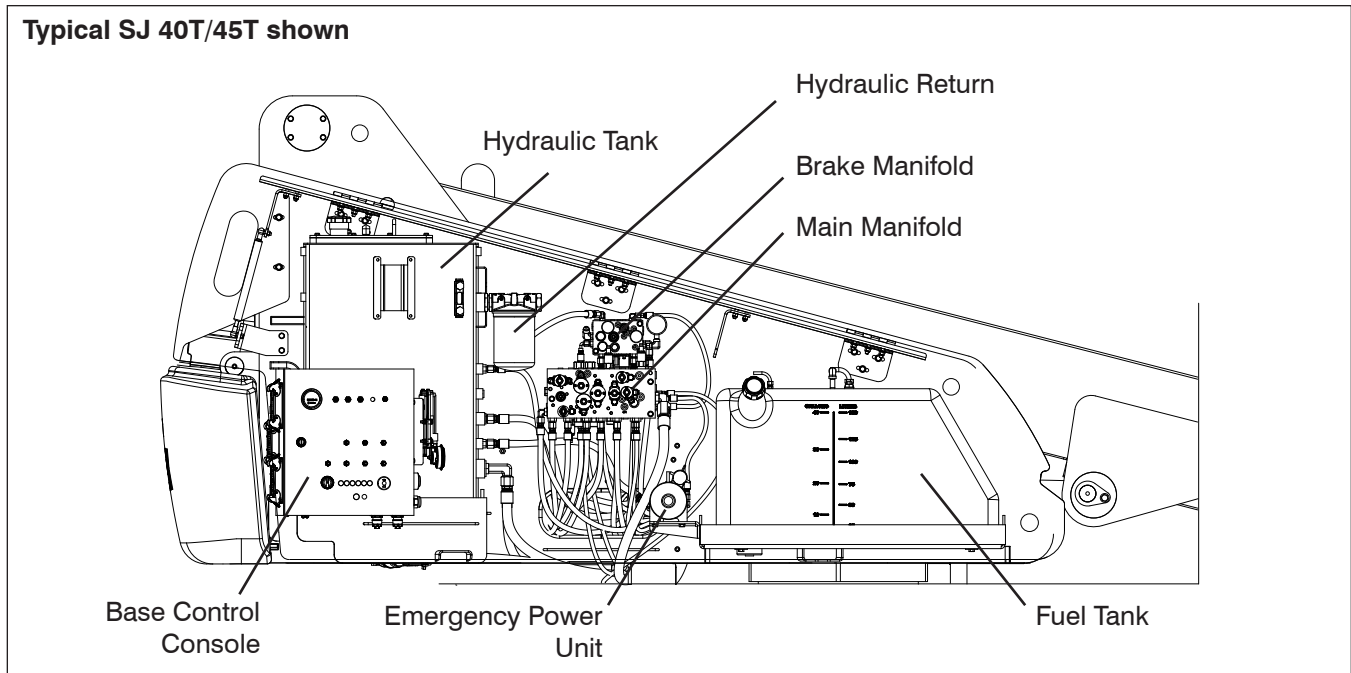

**2.3-6 Control Compartment**

- Ensure all compartment latches are secure and in proper working order.
- **Base Control Console**
  - Ensure all switches are returned to their neutral positions.
  - Ensure there are no loose or missing parts and there is no visible damage.
- **Hydraulic Tank**
  - Ensure hydraulic filler cap is secure.
  - Ensure tank shows no visible damage and no evidence of hydraulic leakage.
- **Hydraulic Oil**
  - Be sure that the boom is in the stowed position, and then visually inspect the sight gauge located on the side of the hydraulic oil tank.
  - The hydraulic oil level should be between the minimum and maximum marks on the sight glass. Add oil as needed. Refer to [Table 4.2b](#) for recommended oil type.
- **Hydraulic Return Filter**
  - Ensure filter element is secure.
  - Ensure there are no signs of leakage or visible damage.

- **Brake and Main Manifolds**
  - Ensure all fittings and hoses are properly tightened and there is no evidence of hydraulic leakage.
  - Ensure there are no loose wires or missing fasteners.
- **Emergency Power Unit**
  - Ensure there are no loose or missing parts and there is no visible damage.
  - Ensure there are no loose wires or missing fasteners.
  - Ensure all fittings and hoses are properly tightened and there is no evidence of hydraulic leakage.
- **Fuel Tank**

**IMPORTANT**

**Before using your aerial platform ensure there is enough fuel for expected use.**

- Ensure fuel filler cap is secure.
- Ensure tank shows no visible damage and no evidence of fuel leakage.

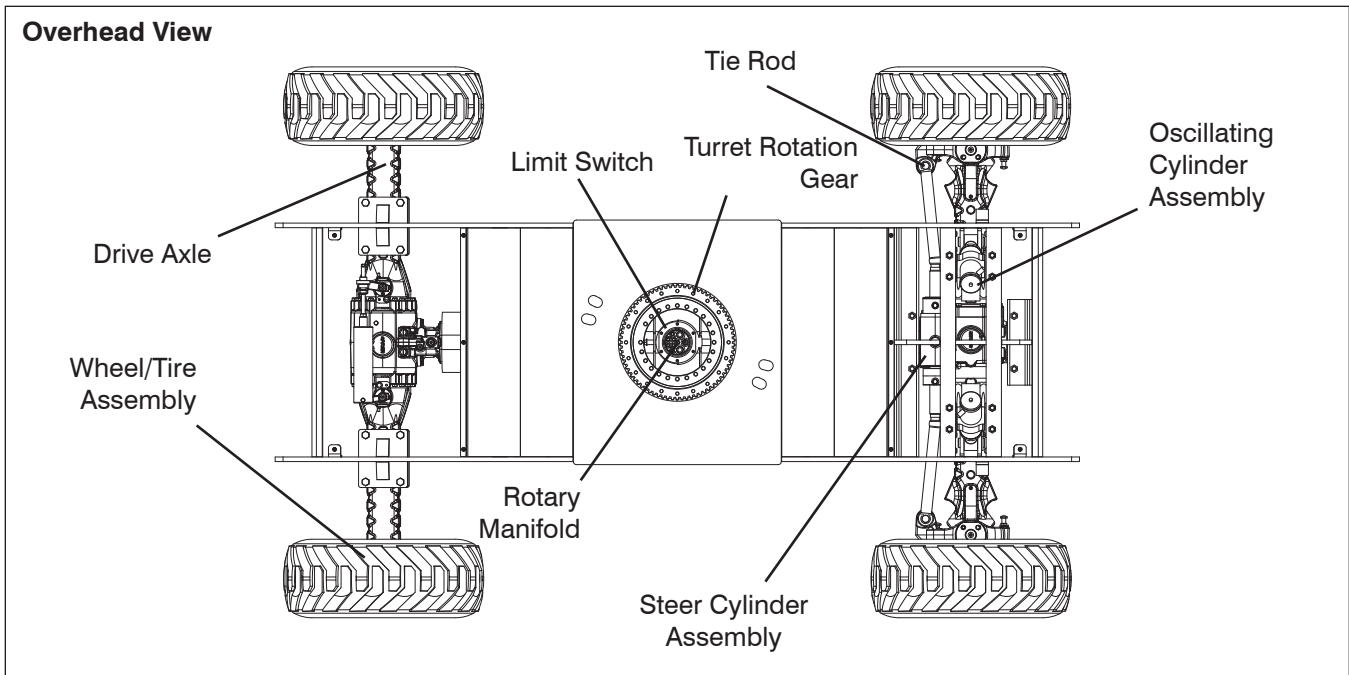

- **Fuel Leaks**
  - Ensure that there no fuel leaks.



**Engine fuels are combustible. Inspect the aerial platform in an open, well-ventilated area away from heaters, sparks and flames. Always have an approved fire extinguisher within easy reach.**

- Ensure fuel tank, shutoff valve, hoses and fittings show no visible damage and no evidence of fuel leakage.

**2.3-7 Base**

- **Turret Transportation Lock**
  - Ensure turret transportation lock is unlocked, there are no loose or missing parts and there is no visible damage.
- **Drive Axle**
  - Ensure drive axle is properly secured, there are no loose or missing parts, all fittings and hoses are properly tightened and there is no evidence of hydraulic leakage.

- **Oscillating Cylinder Assembly**
  - Ensure oscillating cylinder assembly is properly secured, there are no loose or missing parts, all fittings and hoses are properly tightened and there is no evidence of hydraulic leakage.

**NOTE**

Oscillating axle is locked when aerial platform is in low speed. Refer to [Diagram 3.5 Axle Oscillation Diagrams](#).

- **Steer Cylinder Assembly**
  - Ensure steer cylinder assembly is properly secured, there are no loose or missing parts, all fittings and hoses are properly tightened and there is no evidence of hydraulic leakage.

- **Tie Rod**
  - Ensure there are no loose or missing parts, tie rod end studs are locked and there is no visible damage.

- **Wheel/Tire Assembly**

The aerial platform is either equipped with air tires or foam-filled tires. Tire and/or wheel failure could result in an aerial platform tip over. Component damage may also result if problems are not discovered and repaired in a timely fashion.

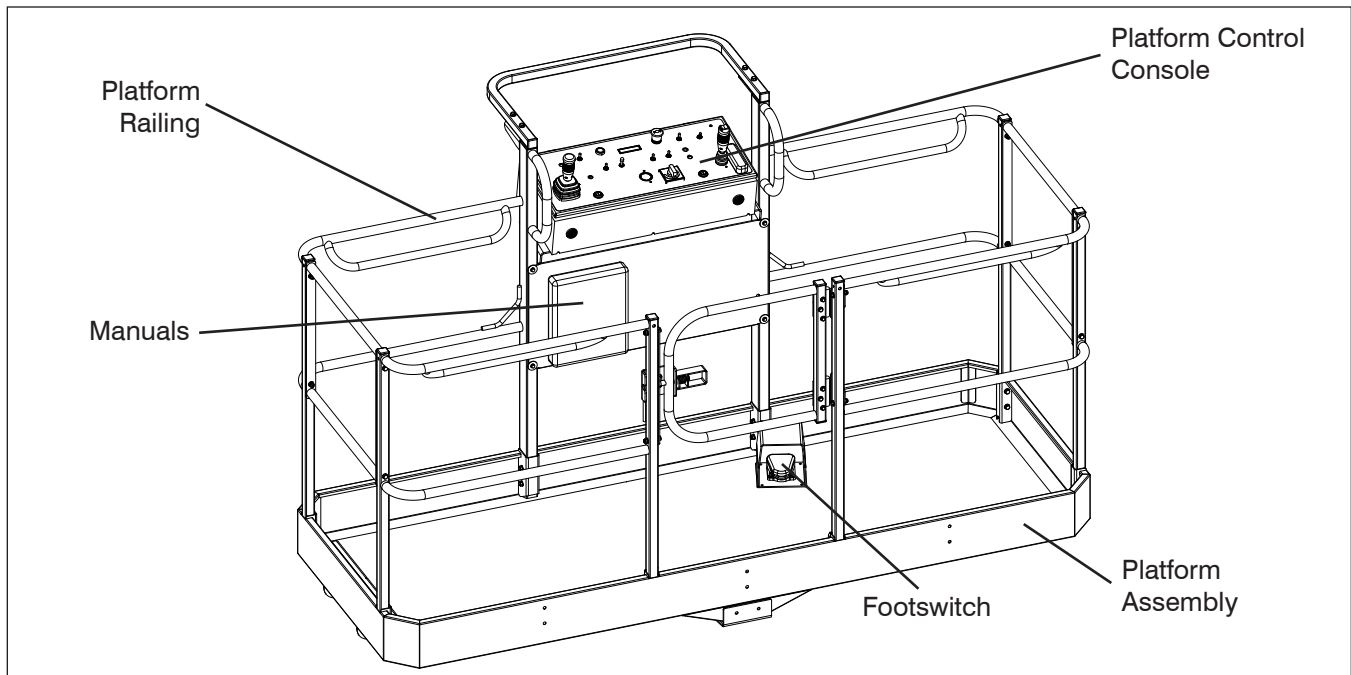

**WARNING**

**An over-inflated tire can explode and may cause death or serious injury.**

- Check all tire treads and sidewalls for cuts, cracks, punctures and unusual wear.
- Check each wheel for damage and cracked welds.
- Check each lug nut for proper torque to ensure none are loose.

To maximize stability, it is essential to maintain proper pressure in all air-filled tires.

- Check each tire with an air pressure gauge and add air as needed.

Refer to [Table 4.4](#) for wheel/tire specifications.



**WARNING**

**Intermixing tires of different types or using tires of types other than those originally supplied with this equipment can adversely affect stability. Therefore, replace tires only with the exact Skyjack-approved type. Failure to operate with matched approved tires in good condition may result in death or serious injury.**

**2.3-8 Manuals**

Ensure a copy of operating manual, and other important documents are enclosed in manual storage box.

- Check to be sure manual storage box is present and in good condition.
- Ensure manuals are legible and in good condition.
- Always return manuals to the manual storage box after use.

**2.3-9 Platform Assembly**

- Ensure there are no loose or missing parts and there is no visible damage.
- Ensure all fasteners are securely in place.
- Ensure all railings are properly positioned and secured.
- Ensure gate is in good working order.
- Ensure footswitch is in good working order and has not been modified, disabled or blocked.

**2.3-10 Platform Control Console**

- Ensure all switches/controllers are returned to neutral and are properly secured.
- Ensure there are no loose or missing parts and there is no visible damage.

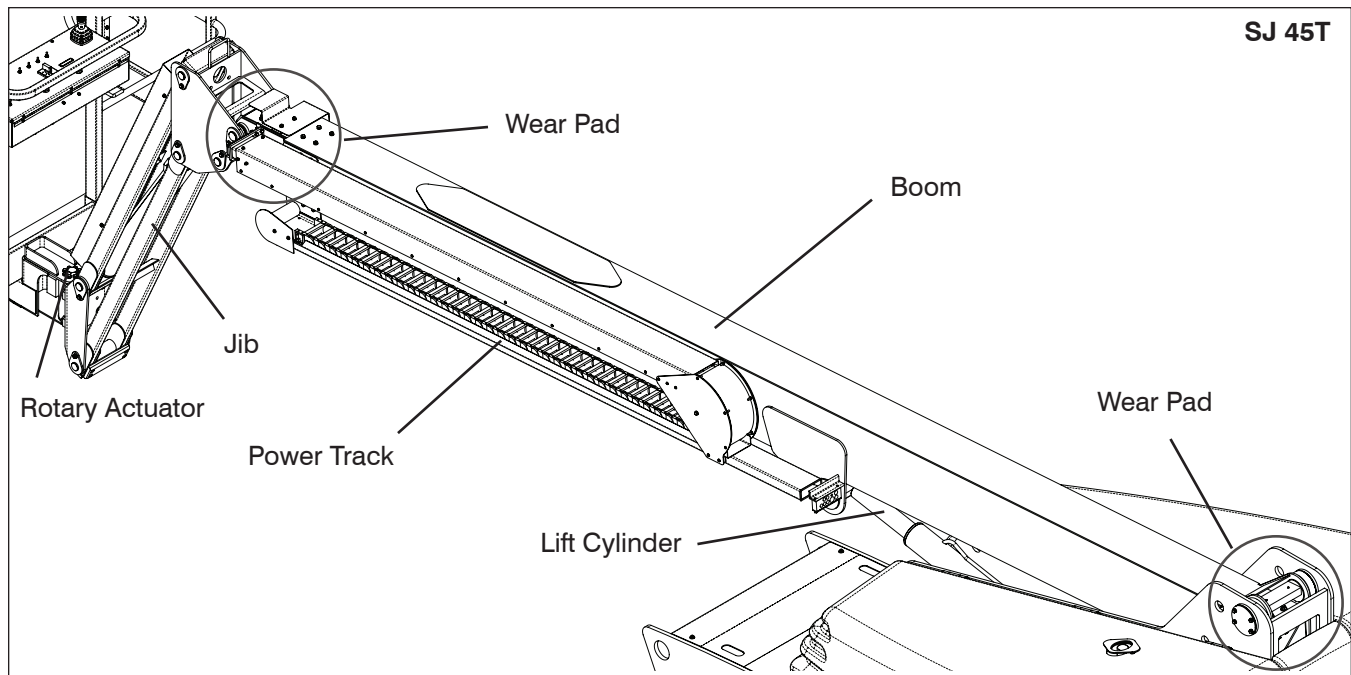

SJ 45T

### 2.3-11 Rotary Actuator

- Ensure there are no loose or missing parts and there is no visible damage.
- Ensure all bolts and pins are properly tightened.
- Ensure all hoses are properly tightened and there is no evidence of hydraulic leakage.

### 2.3-12 Jib (If Equipped)

- Ensure there are no loose or missing parts and there is no visible damage.
- Ensure all bolts and pins are properly tightened.
- Ensure all hoses are properly tightened and there is no evidence of hydraulic leakage.

### 2.3-13 Boom

- Ensure there are no loose or missing parts and there is no visible damage.
- Ensure all bolts and pins are properly tightened.
- Ensure there are no visible cracks in welds or structure and there are no signs of deformation.
- Ensure all hoses are properly tightened and there is no evidence of hydraulic leakage.

### • Cylinders

- Ensure all cylinders are properly secured and there is no evidence of leakage.

### • Wear Pads

- Ensure all bolts are tight, there is no visible damage to the wear pads and that no parts are missing.

### • Hoses

- Ensure all hoses are properly tightened and there is no evidence of hydraulic leakage.

### • Power Track

- Ensure there are no loose or missing parts and there is no visible damage.

### • Cables (61T/66T)

- Ensure there are no loose or missing parts with no signs of visible damage.
- Ensure that nuts are not loose and are locked together.
- Ensure that there are no gaps between springs (see [Figure 2-7](#)). If there are gaps, tighten nuts to remove gaps and then add another half turn more.

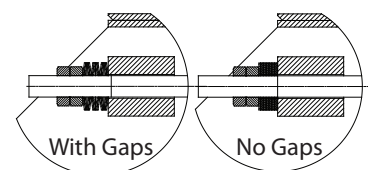
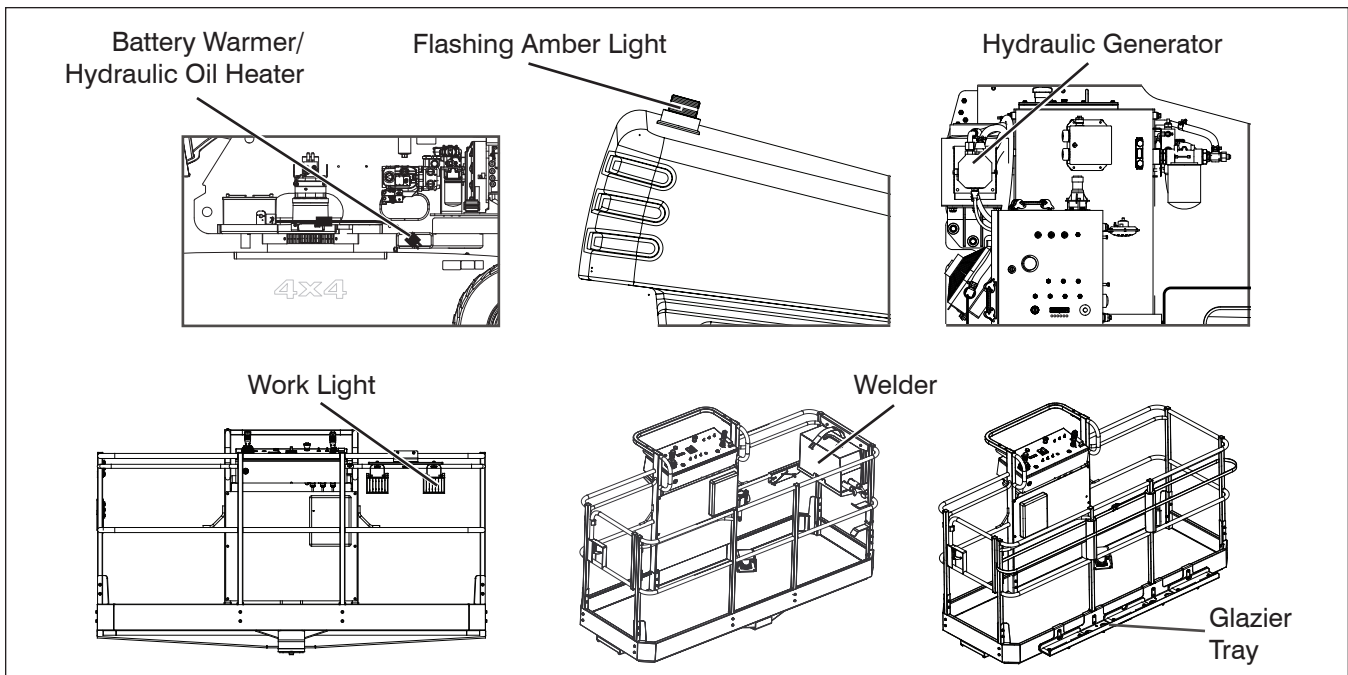

Figure 2-7. Springs



2.3-14 Optional Equipment/Attachments

- **Hydraulic Generator (If Equipped)**
  - Ensure there are no loose or missing parts with no signs of visible damage.
  - Ensure all hoses are properly tightened and there is no evidence of hydraulic leakage.
- **Battery Warmer/Hydraulic Oil Heater (If Equipped)**
  - Ensure battery warmer/hydraulic oil heater cord is properly secured with no signs of visible damage and hydraulic leakage.
- **Welder (If Equipped)**
  - Ensure welder and welder tray are properly secured.
  - Ensure there are no loose or missing parts and there is no visible damage.
  - Ensure there are no loose wires or missing fasteners.

- **Work Light (If Equipped)**
  - Ensure lamps are properly secured with no signs of visible damage.
  - Ensure mounting bracket is properly secured.
  - Ensure there are no loose wires or missing fasteners.
- **Flashing Amber Light (If Equipped)**
  - Ensure lamp is properly secured with no signs of visible damage.
- **Glazier Tray (If Equipped)**
  - Ensure tray, strap, foam supports and cover bumpers are properly secured with no signs of visible damage.
- **Arctic Weather Package (If Equipped)**
  - Ensure battery/hydraulic oil/engine oil heater plug is properly secured with no signs of visible damage and hydraulic leakage.

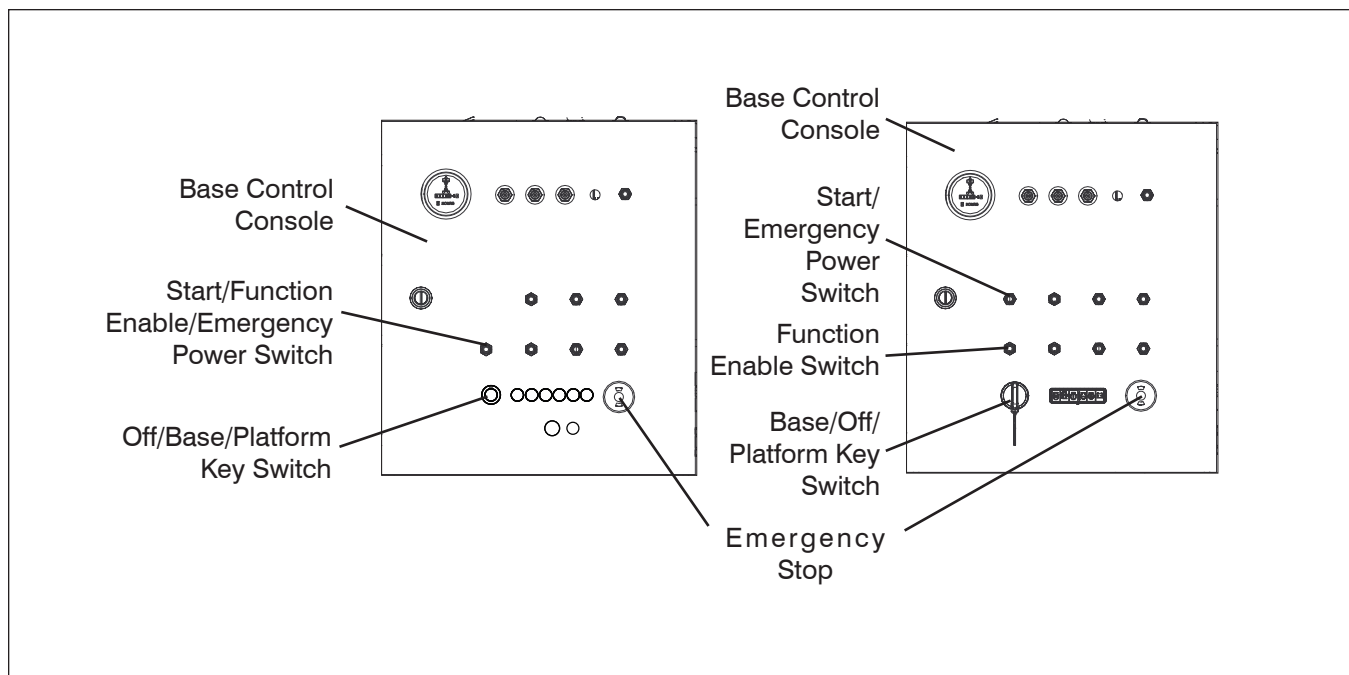

## 2.4 Function Tests

Function tests are designed to discover any malfunctions before aerial platform is put into service. The operator must understand and follow step-by-step instructions to test all aerial platform functions.

### IMPORTANT

**Never use a malfunctioning aerial platform. If malfunctions are discovered, aerial platform must be tagged and placed out of service. Repairs to aerial platform may only be made by a qualified service technician.**

After repairs are completed, operator must perform a pre-operation inspection and a series of function tests again before putting aerial platform into service.

Prior to performing function tests, be sure to read and understand [Section 3.8 - Start Operation](#).

### NOTE

All-function motion alarm should sound while operating any boom and drive function.

### 2.4-1 Test Main Power Disconnect Switch

- In engine compartment, turn main power disconnect switch to “○” off position.  
**Result:** Aerial platform functions should not operate.

- In engine compartment, turn main power disconnect switch to “I” on position.

### NOTE

Close all cowlings before proceeding to next item.

### 2.4-2 Base Control Console

- On platform control console, pull out “●” emergency stop button.
- On base control console, pull out “●” emergency stop button.
- Turn off/base/platform (base/off/platform) key switch to “🔑” base position.
- Start engine by selecting “🔧” start position from start/function enable/emergency power (start/emergency power) switch.

#### • Test Emergency Stop

- Push in “●” emergency stop button.  
**Result:** Engine should shut down and aerial platform functions should not operate.
- Pull out “●” emergency stop button and restart engine.

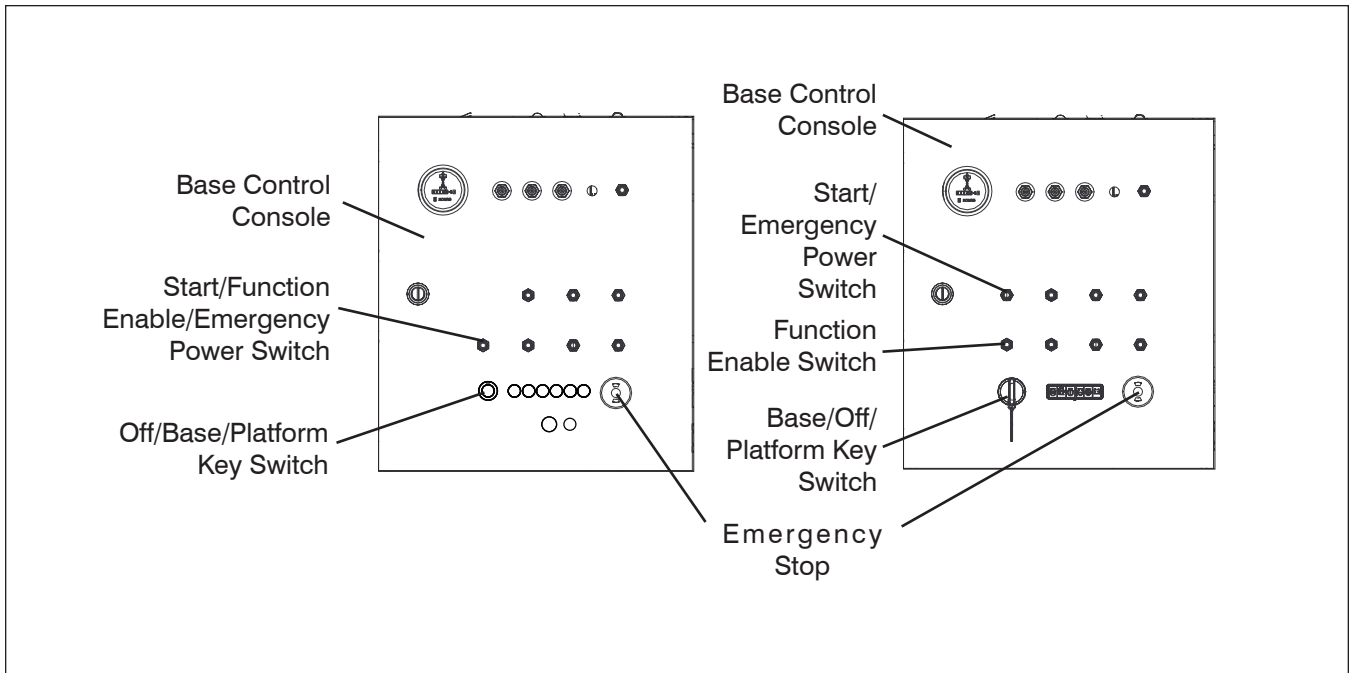



- Test Start/Function Enable/Emergency Power Switch (Function Enable) and All Boom Functions





**WARNING**

Ensure that there are no personnel or obstructions in test area and there is sufficient room for boom to swing.



1. Ensure “” emergency stop button is pulled out.
2. Start engine.
3. Do not hold “” start/function enable/emergency power (function enable) switch in function enable position. Attempt to activate each boom and platform switch.  
**Result:** All boom and platform functions should not operate.
4. Hold “” start/function enable/emergency power (function enable) switch in function enable position and activate each boom and platform function.  
**Result:** Engine speed increases from idle to intermediate. All boom and platform functions should operate as selected.

- Test Platform Self-leveling

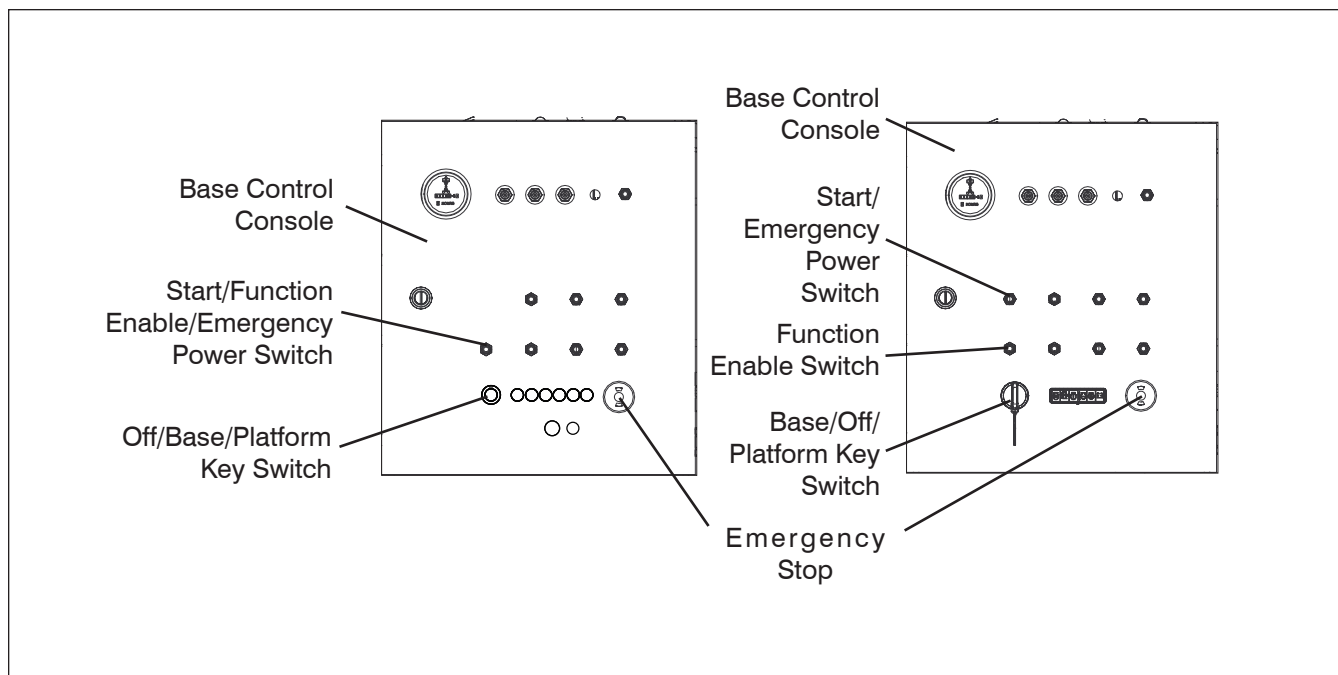
1. Lower boom to stowed position.
2. Adjust platform to a level position using platform leveling switch.
3. Raise “” and lower “” main boom through a full cycle.  
**Result:** Platform should remain level at all time.



• **Test Emergency Power**

1. On base control console, push in “” emergency stop button to turn engine off.
2. On platform control console, push in “” emergency stop button.

 **CAUTION**

**When operating on auxiliary power, do not operate more than one function at a time to avoid overloading 12-Volt auxiliary pump motor. Do not use emergency power unit continuously for more than two minutes.**

**NOTE**

To conserve battery power, test each function through a partial cycle.

 **WARNING**

**Ensure that there are no personnel or obstructions in test area and there is sufficient room for boom to swing.**



3. On base control console, pull out “” emergency stop button.

4. Select “” emergency power position from start/function enable/emergency power (start/emergency power) switch and activate each boom function.  
**Result:** All selected functions should operate.

**NOTE**



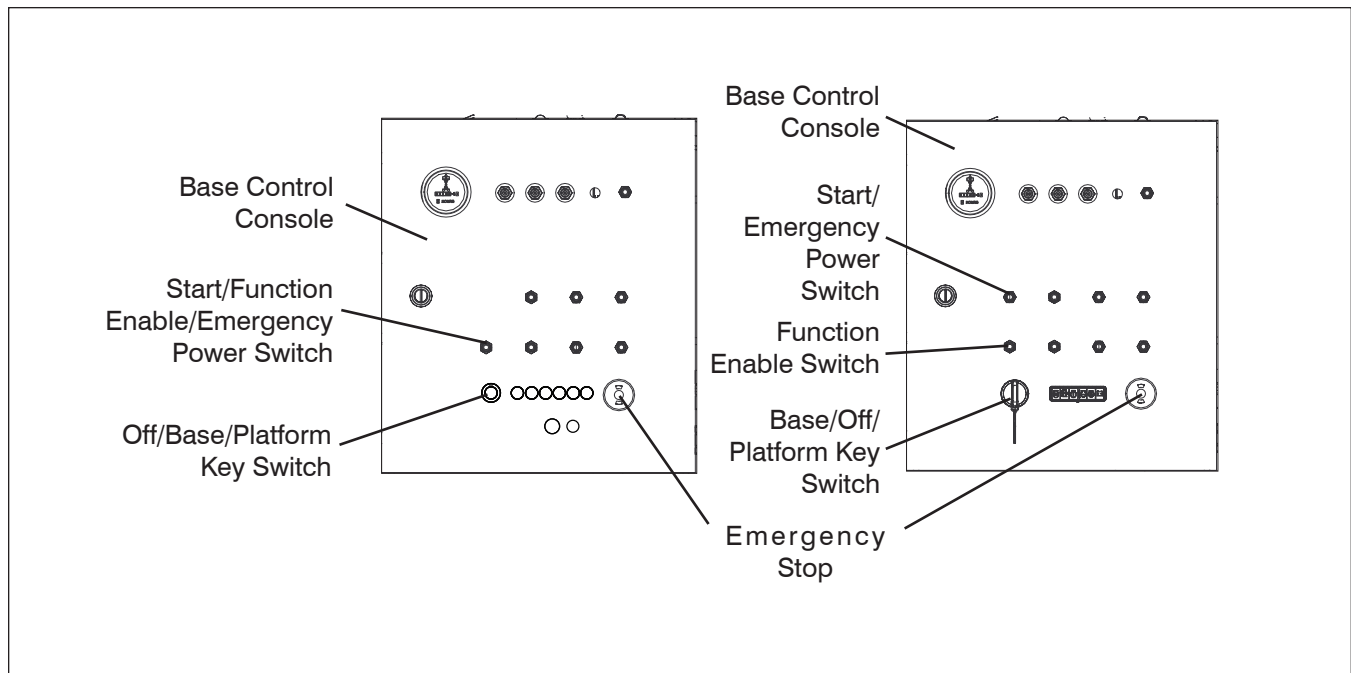

The emergency power unit has two-minute duty cycle.

• **Test Off/Base/Platform (Base/Off/Platform) Switch**

1. Ensure “” emergency stop button is pulled out.
2. Start engine.
3. On base control console, turn off/base/platform (base/off/platform) key switch to “” off position.  
**Result:** Engine should shut down and aerial platform functions should not operate.
4. On base control console, turn off/base/platform (base/off/platform) key switch to “” platform position.

**WARNING**

**Ensure that you maintain three points of contact to mount/dismount platform.**

5. Enter platform and close gate.
6. On platform control console, select “” on position from engine start/on/off switch.
7. Select “” start position from engine start/on/off switch until engine starts.
8. Dismount from platform.
9. On base control console, attempt to activate each boom and platform switch while holding start/function enable/emergency power (function enable) switch in function enable position.  
**Result:** All boom and platform functions should not operate while holding start/function enable/emergency power (function enable) switch in function enable position.
10. Push in “” emergency stop button to turn engine off.
11. Pull out “” emergency stop button.

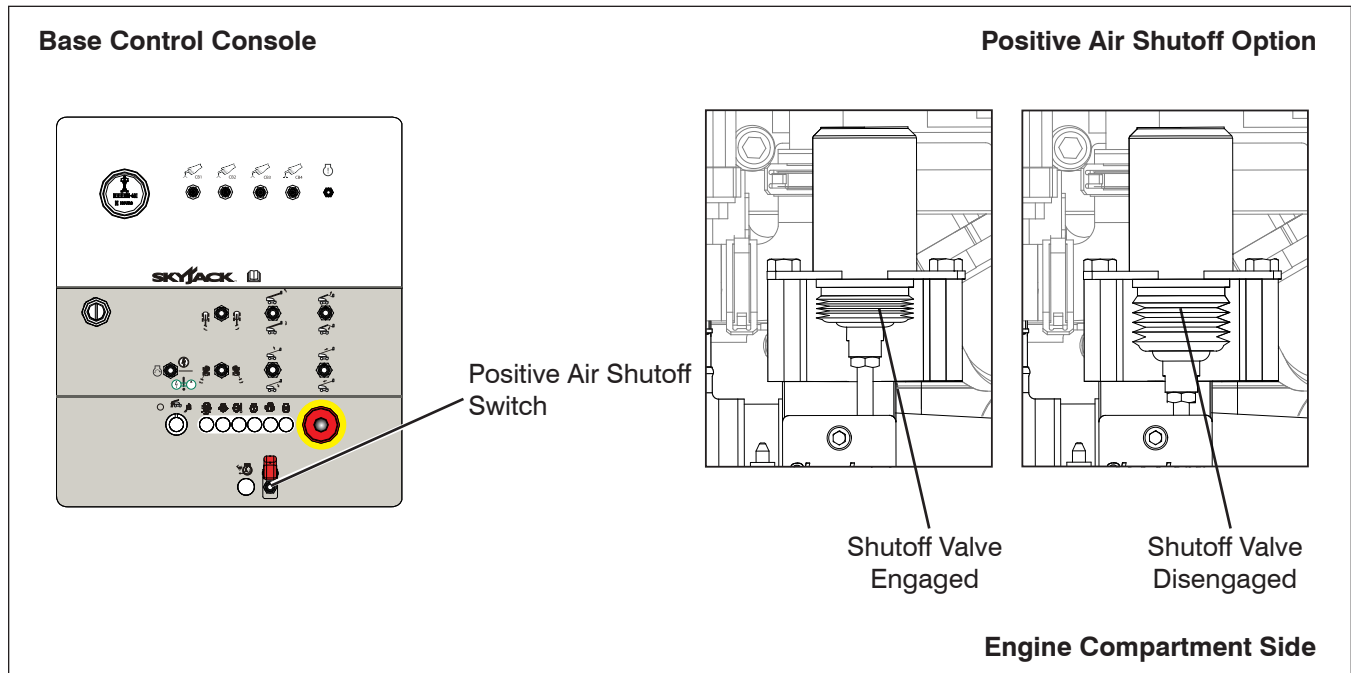

- Test Positive Air Shutoff (If Equipped)



### CAUTION

**This function test should NOT be performed while the engine is running.**

1. Open engine compartment cover.
2. On the base control console, lift switch guard and push rocker switch to “on” position.
3. Push rocker switch to “off” position. LED light should continuously illuminate. Walk back to the engine compartment side of the aerial platform.  
**Result:** The shutoff valve should disengage after 20 seconds (refer to shutoff valve diagrams).
4. Close engine compartment cover. Ensure switch is returned to “off” position and switch guard is down.

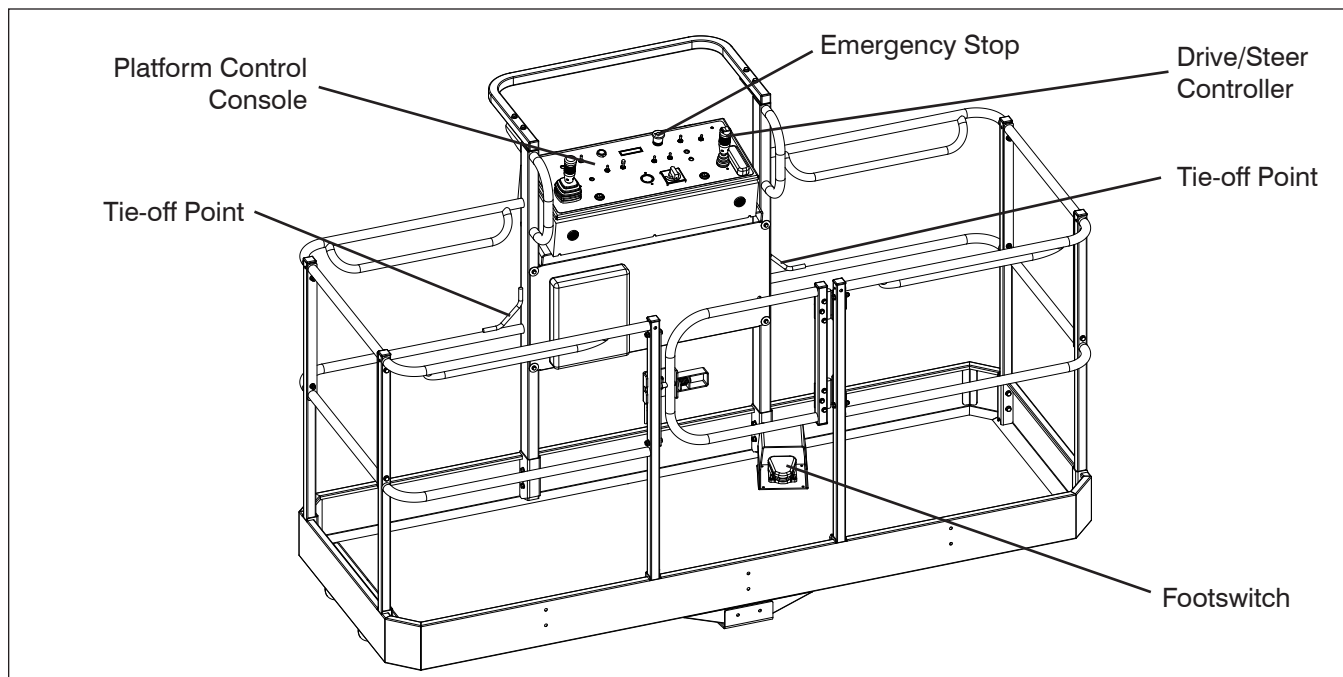

2.4-3 Platform Control Console



**WARNING**

Ensure that you maintain three points of contact to mount/dismount platform.

1. Enter platform and close gate.



**WARNING**



**DO NOT** operate any control on platform control console without proper fall protection secured to designated location in platform. Failure to avoid this hazard could result in death or serious injury!



**WARNING**

Ensure that there are no personnel or obstructions in test area and that there is sufficient room for boom to swing.

• Test Footswitch

1. Pull out “” emergency stop button.
2. Ensure engine start/on/off switch is in “” on position.
3. Do not start engine.

4. Select generator on/off switch to off position (if equipped).
5. Depress and hold footswitch and attempt to start engine by selecting “” start position from engine start/on/off switch.  
**Result:** Engine should not start.
6. Without depressing footswitch, try to start engine.  
**Result:** Engine should start.
7. With engine running and without depressing footswitch, test each boom and platform function.  
**Result:** Aerial platform functions should not operate.

**NOTE**



The emergency power unit has two-minute duty cycle.

**NOTE**

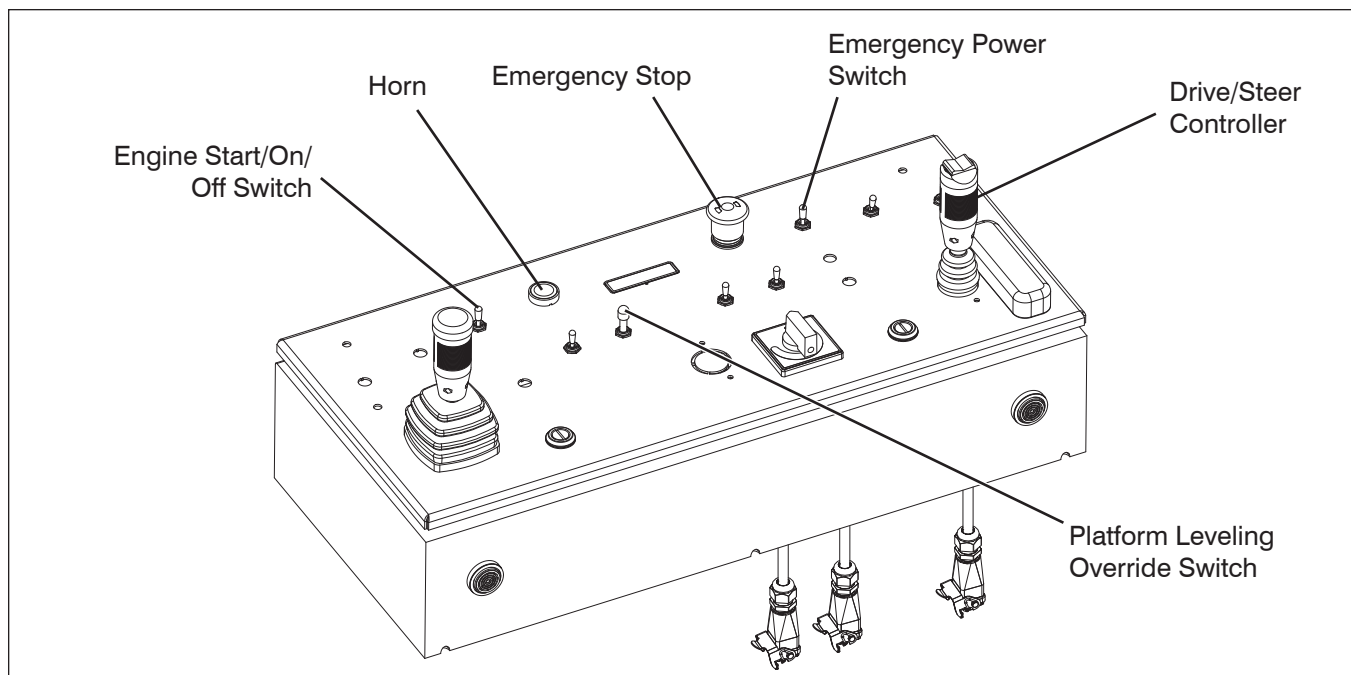
A 15-second anti-tiedown feature deactivates footswitch when operator depresses it for 15 seconds without activating any function.



- **Test Engine Start/On/Off Switch**

1. Ensure engine is running.
2. Select “” off position from engine start/on/off switch.  
**Result:** Engine should shut down and platform control console is disabled.
3. Select “” on position from engine start/on/off switch.  
**Result:** Platform control console is enabled.
4. Start engine by selecting “” start position from engine start/on/off switch.

- **Test Emergency Stop**



1. Ensure engine is running.
2. Push in “” emergency stop button.  
**Result:** Engine should shut down and aerial platform functions should not operate.

- **Test Steering**



1. Pull out “” emergency stop button.

2. Start engine by selecting “” start position from engine start/on/off switch.

3. Depress and hold footswitch.



4. Press rocker switch on top of drive/steer controller to “” left and “” right.  
**Result:** Steer wheels should turn left and right.

- **Test Driving Function**

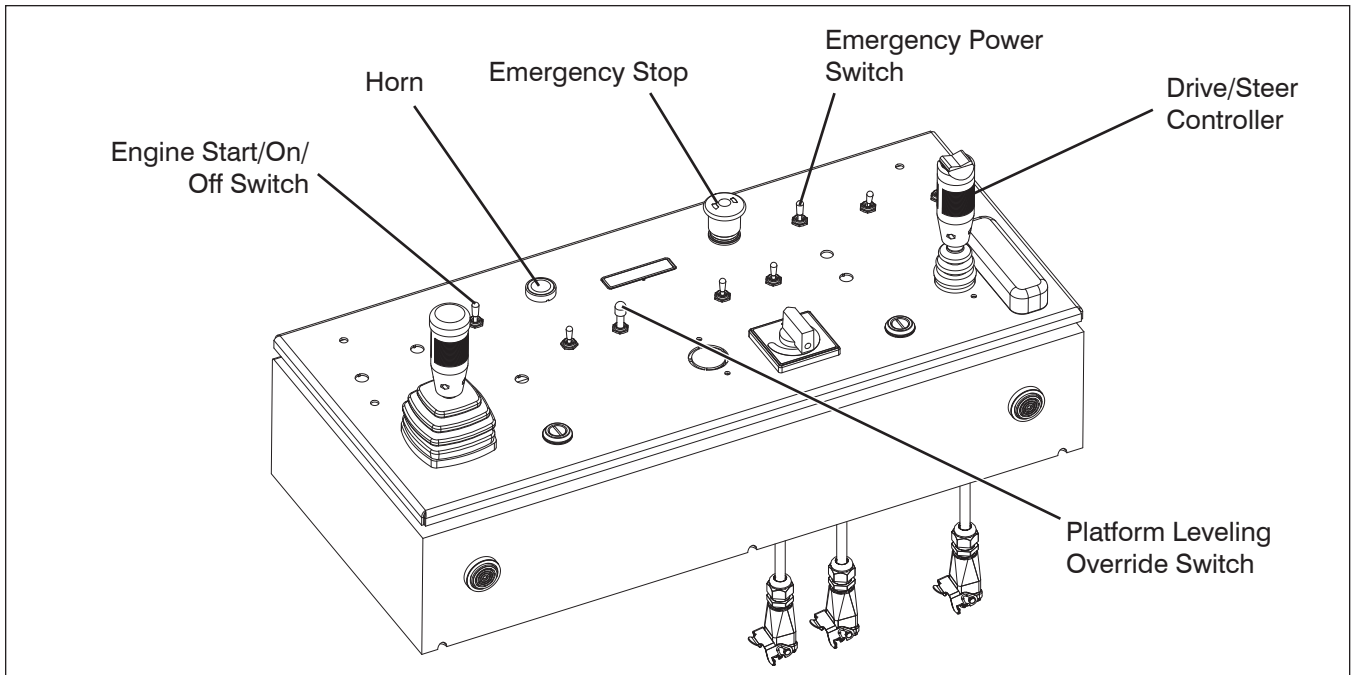
1. Ensure path of intended motion is clear.
2. Ensure boom is in stowed position and fly boom fully retracted.
3. Depress and hold footswitch.
4. Slowly move drive/steer controller in “” forward or “” reverse direction until aerial platform begins to move, and then return handle to center position.  
**Result:** Aerial platform should move in forward or reverse direction, and then come to a stop.







• Test Driving Speed

1. Depress and hold footswitch.
2. Raise “” main boom approximately 14 ft. (4 m) and then slowly move drive/steer controller to full drive position.  
**Result:** The maximum achievable drive speed should be significantly less than stowed drive speed.
3. Lower boom to stowed position.
4. Extend “” fly boom approximately 12 in. (30 cm) and then slowly move drive/steer controller to full drive position.  
**Result:** The maximum achievable drive speed should be significantly less than stowed drive speed.

**NOTE**

To conserve battery power, test each function through a partial cycle.

1. On platform control console, push in “” emergency stop button to turn engine off.
2. Pull out “” emergency stop button.
3. Select “” on position from engine start/on/off switch.
4. Depress and hold footswitch.
5. Turn “” emergency power switch to “” on position and activate each function control handle or switch.  
**Result:** All boom and steer functions should operate. Drive functions should not operate.

• Test Emergency Power



**CAUTION**

**When operating on auxiliary power, do not operate more than one function at a time to avoid overloading 12-Volt auxiliary pump motor. Do not use emergency power unit continuously for two minutes.**

**NOTE**

The emergency power unit has two-minute duty cycle.

• Test Horn

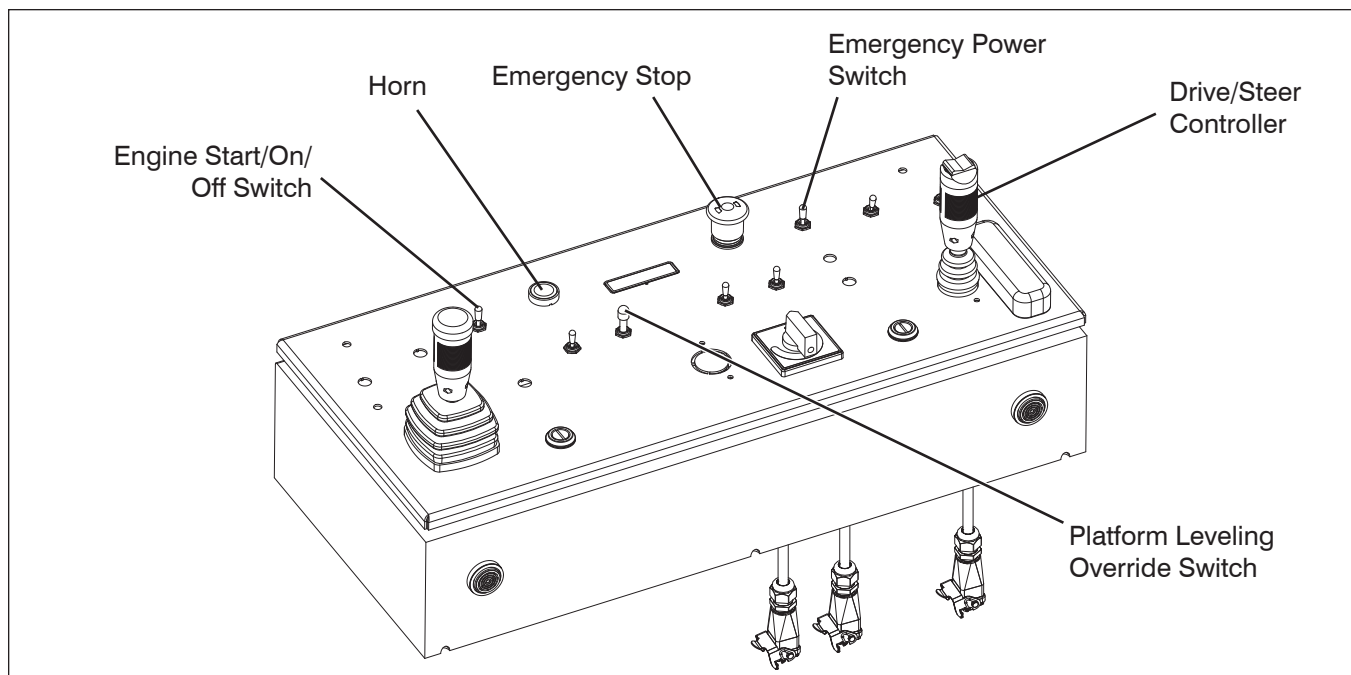

1. Push “” horn pushbutton.  
**Result:** Horn should sound.



- Test Brakes

**WARNING**



**Brakes will engage instantly when you release footswitch, causing aerial platform to stop immediately.**

1. Move aerial platform to a firm level surface to ensure similar traction on left and right.
2. Ensure boom is in stowed position.
3. Depress and hold footswitch and drive aerial platform first “” forward then “” reverse at full speed.

4. Remove your foot from footswitch.  
**Result:** Aerial platform should come to an instant and abrupt stop. If aerial platform does not stop immediately, or if aerial platform pulls to one side while stopping, do not operate aerial platform until brake adjustments have been checked.

- Test Manual Platform Leveling



1. Depress and hold footswitch.

2. On platform leveling override switch, select “” up position to tilt platform up or “” down position to tilt platform down.  
**Result:** Platform should tilt up or down.

- Test Differential Lock Switch

**WARNING**

**Before engaging differential lock, ensure drive/steer controller is in neutral position.**

1. On platform control console, push differential lock switch forward “” to the locked position and then release.  
**Result:** Differential light should turn on. Differential lock should be engaged.
2. Pull differential lock switch backward “” to the unlocked position and then release.  
**Result:** Differential light should turn off. Differential lock will disengage when drive torque is released. Refer to Section 3 for operation.

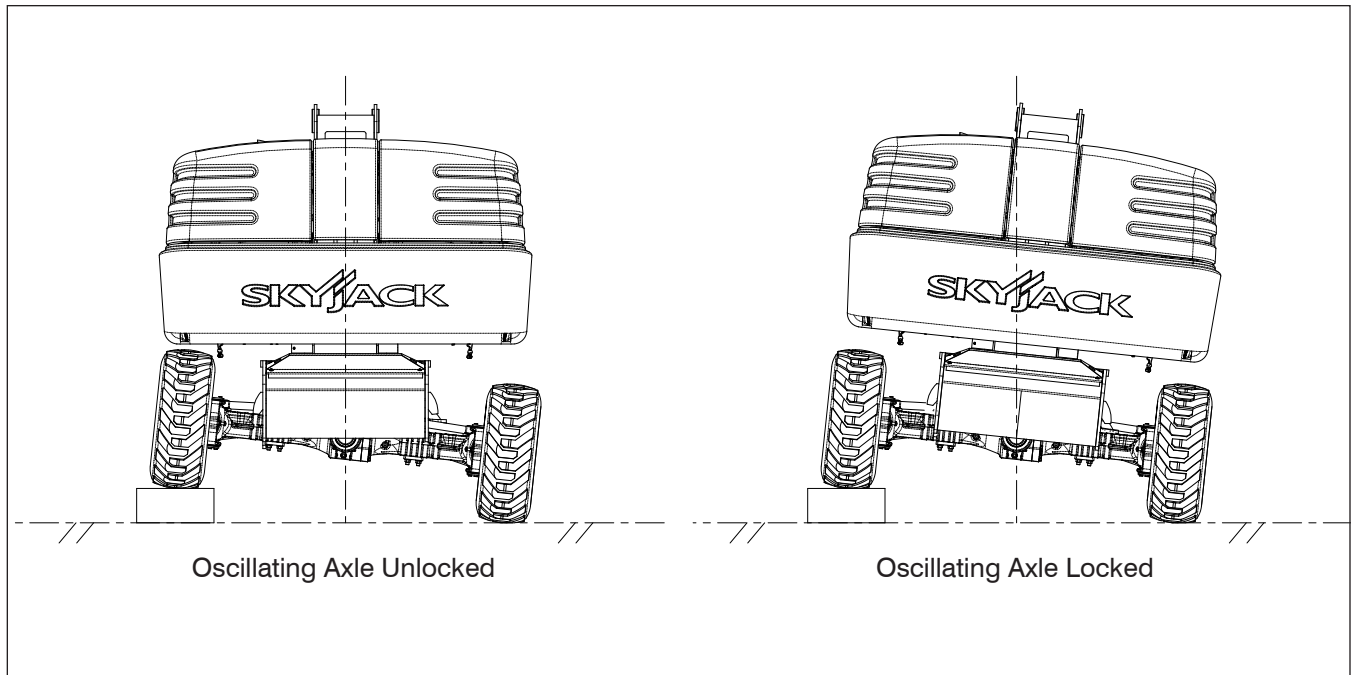

- Test Oscillating Axles



**WARNING**

**DO NOT** operate any control on platform control console without proper fall protection secured to designated location in platform. Failure to avoid this hazard could result in death or serious injury!

1. Extend fly boom 12 in. (30 cm) while on a firm level ground.  
**Result:** The steer axles should be locked.
2. Drive one of the steer tires up onto a 6 in. (15 cm) block or curb.  
**Result:** An appropriate tilt of the aerial platform chassis should occur.
3. Retract fly boom while in tilt position.  
**Result:** The steer axles should unlock and the aerial platform chassis should level itself to ground.

- Test Cables (61T/66T)

1. Raise the main boom to approximately horizontal.
2. Extend and retract the boom sections.  
**Result:** There should be no delay in the movement of the fly boom section.

## 2.5 Winching and Towing Procedure

This section provides the operator with procedure about winching and towing and on how to manually release brakes.



### WARNING

Ensure boom is in stowed position before winching or towing. Sudden motion could cause aerial platform to become unstable. Death or serious injury could result.



### WARNING

In emergency situations where aerial platform functions are not available and lowering is impeded by an obstacle, utmost care must be taken to move aerial platform far enough to clear obstacle. In such cases, operation must be extremely smooth with no sudden movements and must not exceed a speed of 2 in./sec (50 mm/sec).



### WARNING

When pushing, winching or towing, do not exceed 2 mph (3.2 km/h).



### WARNING

Do not winch or tow aerial platform on grade steeper than 50% (2WD & 4WD).



### WARNING

Do not winch or tow aerial platform onto a slope, or brake the towing vehicle rapidly. Do not pull aerial platform down an incline towards a winch.

1. Before winching or towing aerial platform, fully retract, lower and position boom over rear drive wheels in line with direction of travel.
2. Manually release brakes (refer to [Section 2.5-1](#)).
3. Remove wheel chocks or blocks, and then winch or tow aerial platform to desired location.

4. Position aerial platform on a firm and level surface.
5. Chock or block wheels to prevent aerial platform from rolling.
6. Apply brakes by pulling out black brake auto reset valve.

### NOTE

Brakes automatically apply when platform controls are engaged.



### WARNING

Brakes must be applied immediately after reaching desired location.

**2.5-1 To Release Brakes Manually**

Brakes must be manually disengaged for winching or towing.



**WARNING**

**Do not manually disengage brakes if aerial platform is on a slope.**

1. Ensure aerial platform is on level ground. Chock or block wheels to keep aerial platform from rolling.
2. Turn main power disconnect switch to “O” off position.



**CAUTION**

**Do not use hydraulic power with brake disengaged.**

3. Locate the bypass valve on the inboard side of the drive pump. Bypass the drive pump by loosening the valve stem (item 1 - marked with yellow paint) two revolutions counterclockwise.

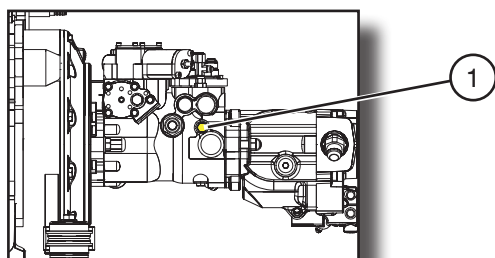

Figure 2-8. Drive Bypass Valve



**CAUTION**

**Do not release brakes before disengaging drive motor!**

4. Push in black brake valve plunger (item 3).

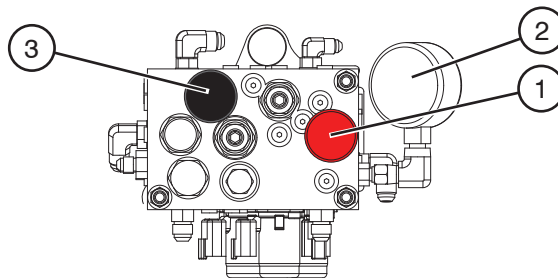

Figure 2-9a. Brake Manifold - SJ40/45T

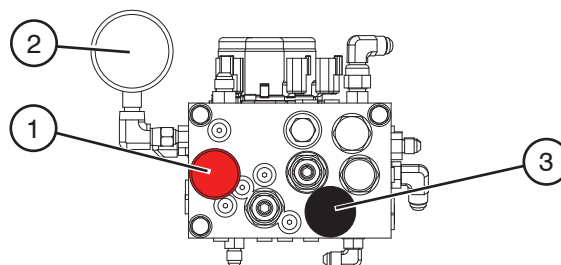

Figure 2-9b. Brake Manifold - SJ61/66T

5. Actuate red hand pump (item 1) slowly by moving knob in and out until pressure gauge (item 2) (if equipped) registers 300 psi/21 bar. DO NOT exceed 350 psi/24 bar. Brake is now released. If MEWP is not equipped with a pressure gauge, refer to the Service manual for instructions on how to install the pressure gauge.



**WARNING**

**Brakes must be applied immediately after reaching desired location. Refer to Section 2.5 on how to reengage brakes.**

## 2.6 Emergency Lowering Procedures

This section guides the operator on how to use emergency lowering system. This system allows platform lowering in the event of an emergency or engine malfunction.

### NOTE



The emergency power unit has two-minute duty cycle.







### CAUTION

**Do not use emergency power unit continuously for more than two minutes.**

### 2.6-1 Base Control Console

1. Ensure engine is off.
2. Pull out “” emergency stop button.
3. Turn key switch to “” base position.
4. Select “” emergency power position from start/function enable/emergency power (start/emergency power) switch and activate desired boom function.

### 2.6-2 Platform Control Console

1. Ensure engine is off.
2. Pull out “” emergency stop button.
3. Select “” on position from engine start/on/off switch.
4. Depress and hold footswitch.
5. Turn “” emergency power switch to “” on position and activate desired boom function.



## 3.0 Operation

This section provides the necessary information needed to operate the aerial platform. It is important that the user reads and understands this manual before operating the aerial platform.

### 3.1 General

In order for this aerial platform to be in good working condition, it is important that the operator meets the necessary qualifications and follow the maintenance and inspection schedule referred to in this manual.

#### 3.1-1 Operator Qualifications

- Only trained and authorized personnel shall be permitted to operate an aerial platform.
- Safe use of this aerial platform requires the operator to understand the limitations and warnings, operating procedures and operator's responsibility for maintenance. Accordingly, the operator must understand and be familiar with this operating manual, its warnings and instructions, and all warnings and instructions on the aerial platform.
- The operator must be familiar with employer's work rules and related government regulations and be able to demonstrate the ability to understand and operate this make and model of aerial platform in the presence of a qualified person.

#### 3.1-2 Operator's Responsibility for Maintenance



#### **WARNING**

**Maintenance must be performed by trained and competent personnel who are familiar with mechanical procedures.**

**Death or serious injury could result from the use of an aerial platform that is not properly maintained or kept in good working condition.**

- The operator must be sure that the aerial platform has been properly maintained and inspected before using it.
- The operator must perform all the daily inspections and function tests found in [Table 4.7](#), even if the operator is not directly responsible for the maintenance of this aerial platform.

#### 3.1-3 Maintenance and Inspection Schedule

- The inspection points covered in [Table 4.7](#) indicate the areas of the aerial platform to be maintained or inspected and at what intervals the maintenance and inspections are to be performed.
- The actual operating environment of the aerial platform may affect the maintenance schedule.



#### **WARNING**

**Use original or manufacturer-approved parts and components for the aerial platform.**

#### 3.1-4 Owner's Inspections

It is the responsibility of the owner to arrange daily, quarterly (or 150 hours) and annual inspections of the aerial platform. Refer to [Table 4.7](#) for recommended maintenance and inspection areas and intervals. A record of annual inspection is kept on a label located close to the base control console on the cowling. Refer to [Table 4.3](#) in this manual.

3.2 Major Components

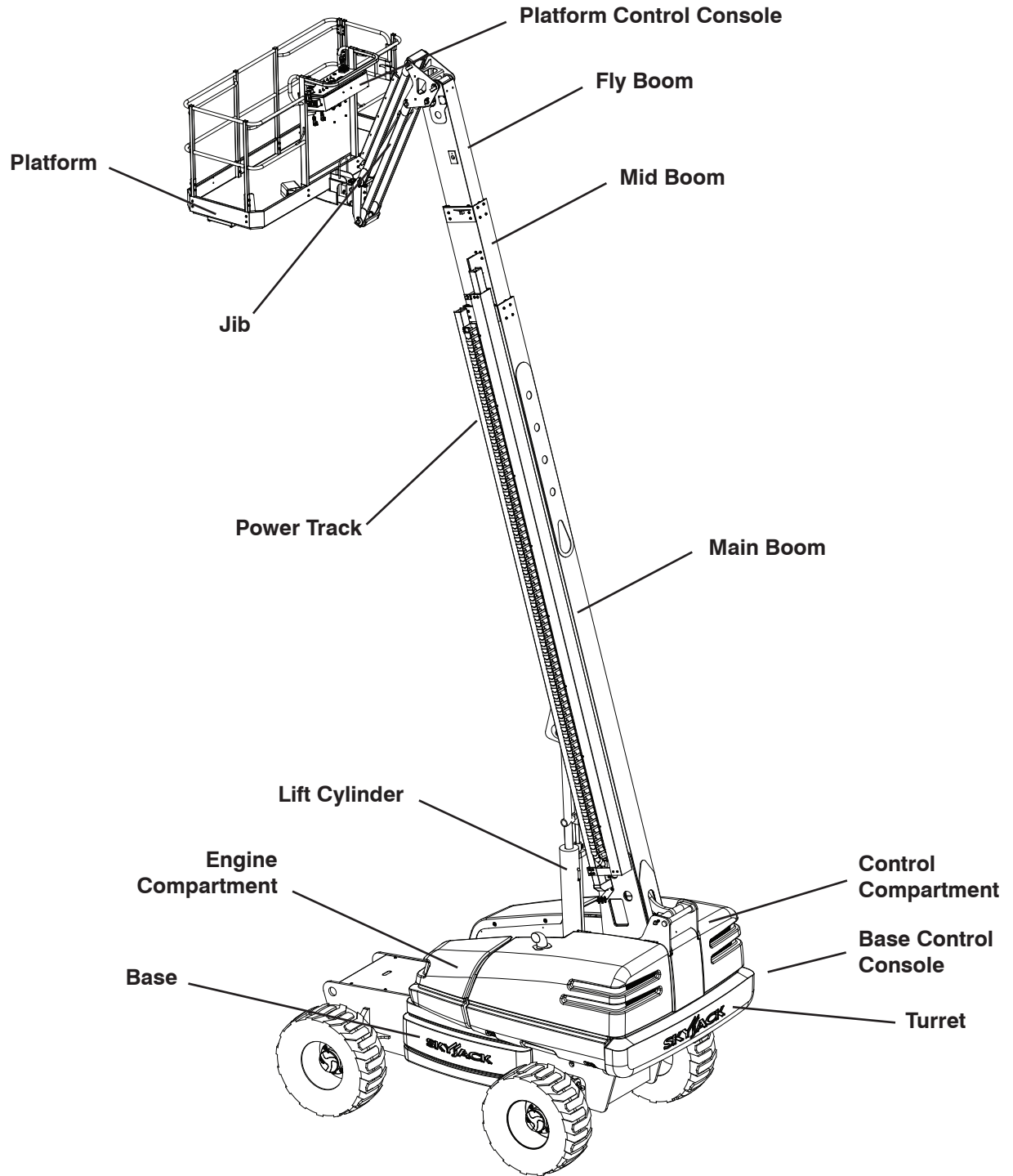

**SKYJACK Telescopic Boom**

### 3.3 Major Assemblies

The aerial platform consists of four major assemblies: the base, turret, boom assembly and platform.

#### 3.3-1 Base

The base is a rigid one-piece weldment. Models equipped with dual-fuel engine have mounting straps for propane tank on each side. The rear axle is hydraulic motor-driven and has a spring-applied, hydraulically released brakes. The front axle is steerable by a hydraulic cylinder.

##### 4WD Models:

The rear axle is coupled to the front axle by a drive shaft.

##### 2WD Models:

The front axle has two non-driven wheels.

#### 3.3-2 Turret

The turret rotates 360 degrees continuously. Upon the turret are two compartments. One compartment contains the engine, hydraulic pumps, battery and swing drive. The other compartment contains the base control console, main hydraulic manifold, function valves, the hydraulic and fuel tanks.

#### 3.3-3 Boom Assembly

The boom is mounted on the turret and consists of a telescoping fly and main boom assembly. Model 66T has an additional mid boom section. The telescoping boom mechanism uses two double-acting hydraulic cylinders with holding valves to control vertical movement. Cables are used to extend the fly boom section in the 66T model. SJ 45T & SJ 66T models are equipped with a 60 in. (150 cm) boom jib, controlled by a double-acting hydraulic cylinder.

#### 3.3-4 Platform

The platform is constructed of a skid-resistant deck surface allowing visibility through the deck and a 43 in. (109 cm) high tubular steel railing system with mid rails and 6 in. (15 cm) toe boards. The platform can be entered through a swing side gate or an optional swing gate at the center of the railing system. The platform can be rotated in either direction. An AC GFI outlet is also located on the platform.

### 3.4 Serial Number Nameplate

The serial number nameplate, located at the rear of the aerial platform, lists the following:

- Model number
- Serial number
- Maximum capacities
- Maximum number of persons permissible on the platform
- Maximum manual force
- Aerial platform weight
- Maximum drivable height
- Maximum platform height
- System pressure
- Lift pressure
- Maximum wheel load
- Voltage

### 3.5 Component Identification

The following descriptions are for identification, explanation and locating purposes only.

#### 3.5-1 Turret Transportation Lock

This locking device is located in the turret.

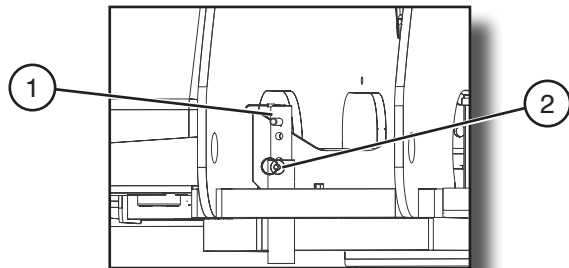

Figure 3-1. Turret Transportation Lock

1. **Turret Transportation Lock** - This locking device is used to lock turret in place during shipping only.
2. **Turret Transportation Lock Retaining Pin** - This retaining pin is used to hold transportation lock in either locked or unlocked position.

Refer to [Section 3.10-2](#) for procedure on how to lock the turret.

#### 3.5-2 All Motion Alarm

This alarm produces an audible sound when any boom function is activated. On aerial platforms with certain options, a flashing amber light will accompany this alarm.

#### 3.5-3 Manual Storage Box

This weather-resistant box is mounted under the control console on the platform. It contains operating manual and other important documents. The operating manual for this make and model of aerial platform must remain with the aerial platform and should be stored in this box.



### 3.6 Component Identification (Optional Equipment/Attachments)

The following descriptions are for identification, explanation and locating purposes only.

#### 3.6-1 Tire Sealant (If Equipped)

This option is identified with a tire sealant label located at the rim of the wheel.

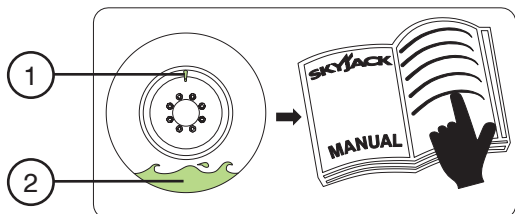

Figure 3-2. Tire Sealant Label

**Tire Sealant Label** - This label indicates that tire sealant is present inside the tires.

1. **Tire Valve Stem Cap** - This green valve stem cap is substituted onto air tires to indicate sealant has been installed.
2. **Sealant** - This symbol signifies that tire is equipped with sealant.



#### **WARNING**

**The operator must properly handle tires with sealant.**

- **When depressurizing, inflating or checking tire pressure, ensure that valve stem is at the top to prevent sealant from entering the stem (refer to Figure 3-2).**
- **If tire no longer holds pressure, replace tire.**



#### **WARNING**

**The sealant contains propylene glycol. Do not ingest, inhale or get into eyes. If it gets into your eyes, flush with water for 15 minutes. Consult physician.**

#### 3.6-2 AC Outlet on Platform (If Equipped)

This outlet is a source of AC power on the platform. The outlet is located on the right side of platform control console and the plug is located beside hydraulic tank in control compartment.



Figure 3-3. AC Outlet and Electrical Plug

#### 3.6-3 Cold Weather Start (If Equipped)

The battery warmer/hydraulic oil heater cord is located on the engine compartment near the battery.

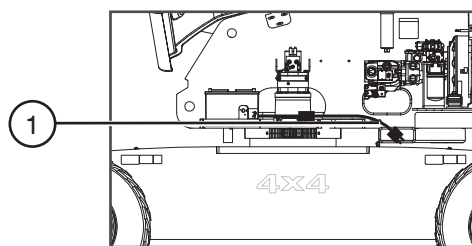

Figure 3-4. Battery Warmer/Hydraulic Oil Heater Cord

1. **Battery Warmer/Hydraulic Oil Heater Cord** - This cord is plugged into the AC outlet at least 4 hours before starting engine when temperature gets below  $-10^{\circ}\text{C}$  ( $+14^{\circ}\text{F}$ ).

**3.6-4 Flashing Amber Light (If Equipped)**

The flashing amber light is located on top of the turret of the aerial platform.

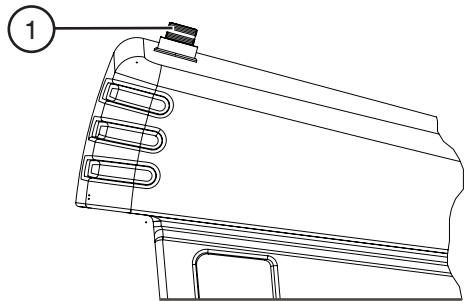

Figure 3-5. Flashing Amber Light

1. **Flashing Amber Light** - This light flashes when boom function is activated. This works in conjunction with all motion alarm.

**3.6-5 Work Light (If Equipped)**

The work light assembly is mounted on the railings of the platform.

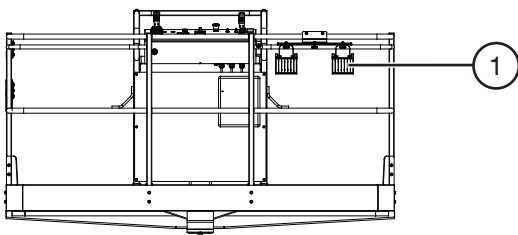

Figure 3-6. Work Light

1. **Work Light** - This light turns on when plugged into the AC outlet on the platform.



**WARNING**

**Work lights are not intended to replace the ambient lighting required to navigate and operate this aerial platform.**

**3.6-6 Glazier Tray (If Equipped)**

The tray is installed on the front side of the platform.

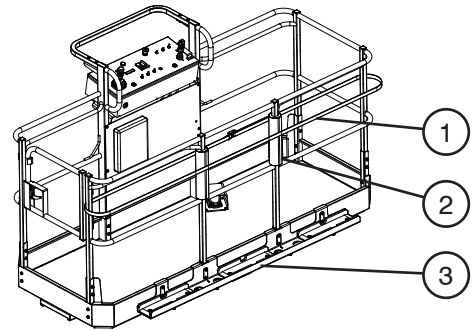

Figure 3-7. Glazier Tray

1. **Strap** - This strap is used to secure panel in place.
2. **Foam Support** - This foam support with cover bumper is used as a cushion to protect the panel.
3. **Glazier Tray** - This tray is used to carry the panel.

**NOTE**

The combined weight of attachment, panels, occupants and tools should not exceed platform rated capacity.

**3.6-7 Welder (If Equipped)**

The welder is installed on the platform. Refer to welder's operating manual for proper operation and maintenance.

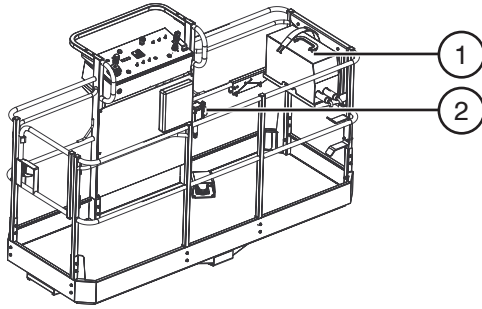

Figure 3-8. Welder

1. **Welder** - This equipment is plugged into its dedicated AC outlet on the platform.
2. **Welder AC Outlet** - This AC outlet is dedicated for the welder.

**NOTE**

In sub-zero temperatures, the hydraulic oil should be warmed, prior to operating the welder.

**NOTE**

This option adds 90 lb. (41 kg) to the platform. This weight must be included when determining the total load on the platform, including personnel and other materials.

**WARNING**

Only qualified persons should install, operate, maintain and repair the welder.

**CAUTION**

Breathing welding fumes and gases can be hazardous to your health.

**3.6-8 Arctic Weather Package (If Equipped)**

The heater plug is located on the engine compartment near the battery.

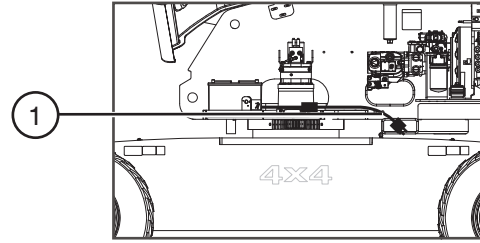

Figure 3-9. Heater Plug

1. **Battery/Hydraulic Oil/Engine Oil Heater Plug** - This cord is plugged into the AC outlet at least 3 hours before starting engine when temperature gets below  $-18^{\circ}\text{C}$  ( $0^{\circ}\text{F}$ ).

### 3.7 Operator's Responsibility

It is the responsibility of the operator, prior to each work shift, to perform the following:

#### 1. Visual and Daily Maintenance Inspections

- are designed to discover any damage of components before the aerial platform is put into service.
- are done before the operator performs the function tests.



#### **WARNING**

**Failure to locate and repair damage, and discover loose or missing parts may result in an unsafe operating condition.**

#### 2. Function Tests

- are designed to discover any malfunctions before the aerial platform is put into service.

#### **IMPORTANT**

**The operator must understand and follow the step-by-step instructions to test all aerial platform functions.**

The operator should make a copy of the Operator's Checklist (see [Table 4.8](#)) and fill out the visual and daily maintenance inspections and the function tests sections while performing the items outlined in [Section 2.3](#) and [Section 2.4](#).

#### **IMPORTANT**

**If aerial platform is damaged or any unauthorized variation from factory-delivered condition is discovered, aerial platform must be tagged and removed from service.**

Repairs to the aerial platform may only be made by a qualified service technician. After repairs are completed, the operator must perform visual and daily maintenance inspections & function tests again.

Scheduled maintenance inspections shall only be performed by qualified service technician (see [Table 4.7](#)).

### 3.8 Start Operation

Carefully read and completely understand the Operating Manual and all warnings and instruction labels (refer to [Section 5 - Labels](#)) on the aerial platform.



#### **WARNING**

**DO NOT operate this aerial platform without proper authorization and training. Failure to avoid this hazard could result in death or serious injury.**

Before operating this aerial platform, perform the following steps:

1. Visual and daily maintenance inspections (see [Section 2.3](#))
2. Function tests (see [Section 2.4](#))
3. Jobsite inspection  
It is the responsibility of the operator to perform a jobsite inspection and avoid the following hazardous situations:
  - holes or drop-offs
  - ditches or soft fills
  - floor obstructions, bumps or debris
  - overhead obstructions
  - electrical cords, hoses and high voltage conductors
  - hazardous locations
  - inadequate surface support to withstand all load forces imposed by the aerial platform
  - wind and weather conditions
  - the presence of unauthorized personnel
  - other possible unsafe conditions



#### **WARNING**

**An operator should not use any aerial platform that:**

- does not appear to be working properly.
- has been damaged or appears to have worn or missing parts.
- has alterations or modifications not approved by the manufacturer.
- has safety devices which have been altered or disabled.
- has been tagged or locked out for non-use or repair.





**Failure to avoid these hazards could result in death or serious injury.**

#### 3.8-1 To Activate Base Control Console



#### **WARNING**

**Ensure that you maintain three points of contact to mount/dismount the platform.**

1. Enter platform and close gate.
2. On platform control console, pull out “” emergency stop button.
3. In engine compartment, turn main power disconnect switch to “I” on position.
4. On base control console, turn off/base/platform (base/off/platform) key switch to “” base position.
5. Pull out “” emergency stop button.
6. Select “” start position from start/function enable/emergency power (start/emergency power) switch until engine starts.



#### **WARNING**

**DO NOT over crank the starter. If engine fails to start after multiple attempts, consult “Troubleshooting Information,” in the Service and Maintenance Manual.**

For aerial platform with cold weather start option:

7. Disconnect battery warmer/hydraulic oil heater from AC outlet after engine starts.
8. Allow engine to run, for approximately 10 minutes, to reach operating temperature before driving.

**3.8-2 To Rotate Platform Using Base Control Console**

1. Activate function enable “

**3.8-3 To Rotate Turret Using Base Control Console**



**WARNING**  
When rotating the turret, ensure that there are no personnel or obstructions in the path of rotation, including blind spots.

1. Activate function enable “

**NOTE**

Turret can be rotated continuously 360 degrees.

**3.8-4 To Move Jib Up and Down Using Base Control Console (If Equipped)**

1. Activate function enable “

**3.8-5 To Raise or Lower Main Boom Using Base Control Console**

1. Activate function enable “

**3.8-6 To Extend or Retract Fly Boom Using Base Control Console**

1. Activate function enable “

**3.8-7 To Level Platform Using Base Control Console**

1. Activate function enable “

**SKYJACK**  
Page 52

### 3.8-8 To Operate Using Emergency Power Switch at Base Control Console

This is a momentary-type switch. This switch allows all functions except the drive function to operate in the event of engine malfunction. Refer to [Section 2.6](#) for the emergency lowering procedure.

#### NOTE



The emergency power unit has two-minute duty cycle.



#### CAUTION

**Do not use emergency power unit continuously for two minutes.**

### 3.8-9 To Activate Platform Control Console

1. In engine compartment, turn main power disconnect switch to “I” on position.
2. On base control console, turn off/base/platform (base/off/platform) key switch to “” platform position.
3. On base control console, pull out “” emergency stop button.





#### WARNING

**Ensure that you maintain three points of contact to mount/dismount the platform.**



#### WARNING

**DO NOT operate any control on operator’s control console without proper fall protection secured to the designated location in the platform. Failure to avoid this hazard could result in death or serious injury.**

4. Enter platform and close gate.
5. Attach body harness lanyards of each occupant to platform lanyard rings.
6. On platform control console, pull out “” emergency stop button.
7. Select “” start position from engine start/on/off switch until engine starts.





#### WARNING

**DO NOT over crank the starter. If engine fails to start after multiple attempts, consult “Troubleshooting Information,” in the Service and Maintenance Manual.**

#### NOTE

Engine will not start if you are pressing down on the footswitch.

8. Select desired engine RPM using throttle switch: “” high or “” low.





#### WARNING

- **DO NOT drive or steer the aerial platform when the platform position does not allow you a clear view of the base.**
- **Your area of operation should be cordoned from other personnel or equipment.**

**3.8-10 To Drive Forward or Reverse Using Platform Control Console**



**When you are in the platform and positioned over an axle, the direction you are facing will be forward.**

1. Depress and hold footswitch.
2. Push and hold drive/steer controller in this direction  to drive forward or  to drive backward.
3. Release controller handle to stop.





**The drive orientation can change when the turret is swung 90 degrees off center of the normal driving position (roughly when boom is swung past the rear tire). Drive re-orientation will not occur while driving and rotating until the joystick is released for 6 seconds or when the footswitch is released.**



- When driving on a slope:**
- **Torque Switch MUST be in high torque mode.**
  - **DO NOT exceed the rated gradeability listed in Table 4.2a.**
  - **Ensure fuel level is above half to avoid a possible stall condition.**



**3.8-11 To Steer Using Platform Control Console**

1. Depress and hold footswitch.
2. Press rocker on top of drive/steer controller in this direction  to steer left or  to steer right.



**NOTE**

Driving and steering may be active at the same time.



**3.8-12 To Move Jib Up and Down Using Platform Control Console (If Equipped)**

1. Depress and hold footswitch.
2. On jib up/down switch, select  to move jib up or  to move jib down. Vary speed with  boom speed adjuster dial. Release switch to stop.



**3.8-13 To Extend or Retract Fly Boom Using Platform Control Console**

1. Depress and hold footswitch.
2. On fly boom extend/retract switch, select  to extend fly boom or  to retract fly boom. Vary speed with  boom speed adjuster dial. Release switch to stop.



**3.8-14 To Level Platform Using Platform Control Console**

1. Depress and hold footswitch.
2. On platform leveling override switch, select  to tilt platform up or  to tilt platform down. Release switch to stop.

**3.8-15 To Rotate Platform Using Platform Control Console**

1. Depress and hold footswitch.
2. On platform rotation switch, select  to rotate platform left or  to rotate platform right. Vary speed with  boom speed adjuster dial. Release switch to stop.

### 3.8-16 To Raise or Lower Main Boom Using Platform Control Console



1. Depress and hold footswitch.
2. Push and hold boom/turret controller in this direction  to raise main boom or  to lower main boom.
3. Release controller handle to stop.

### 3.8-17 To Rotate Turret Using Platform Control Console



#### WARNING

When rotating the turret, ensure that there are no personnel or obstructions in the path of rotation, including blind spots.

1. Depress and hold footswitch.
2. Push and hold boom/turret controller in this direction  to rotate clockwise or  to rotate counterclockwise.
3. Release controller handle to stop.

#### NOTE

Turret can be rotated continuously 360 degrees.

### 3.8-18 To Sound Horn

1. Press  horn pushbutton to sound horn. Release pushbutton to stop sounding horn.

### 3.8-19 To Operate Using Emergency Power Switch at Platform Control Console

This is a momentary-type switch. This switch allows all functions except drive function to operate in the event of engine malfunction. Refer to [Section 2.6](#) for the emergency lowering procedure.

#### NOTE

The emergency power unit has two-minute duty cycle.



#### CAUTION

Do not use emergency power unit continuously for two minutes.

### 3.8-20a To Engage Differential Lock Switch

1. Depress and hold footswitch.
2. On platform control console, push differential lock switch forward  to the locked position and then release.



### 3.8-20b To Disengage Differential Lock Switch

1. Ensure path of intended motion is clear.
2. Depress and hold footswitch.
3. Pull differential lock switch backward  to the unlocked position and then release.

#### NOTE

To disengage differential lock mechanism, it may be necessary to release drive torque. This can be accomplished by operating drive (alternating directions) and/or steer functions (alternating directions).

### 3.8-21 Shutdown Procedure

1. Completely retract boom and lower platform.
2. Push in  emergency stop button on platform control console and on base control console.
3. Turn base/off/platform key switch to  off position. Remove key.
4. Turn main power disconnect switch to  off position.

For aerial platform with cold weather start option:

#### NOTE

When temperature gets below  $-10^{\circ}\text{C}$  ( $+14^{\circ}\text{F}$ ), ensure aerial platform is parked close to AC outlet.

5. Plug in battery warmer/hydraulic oil heater into AC outlet at least 4 hours before starting engine.

**3.8-22 Hydraulic Generator (If Equipped)****To start the hydraulic generator:**

1. Ensure that engine is running.
2. On platform control console, turn generator on/off switch to “” on position.

**To restore normal operation:**

1. On platform control console, turn generator on/off switch to “” off position.

**NOTE**

An engine shut down will turn the generator off. Normal boom functions are disabled while the generator is on.

**3.8-23 Glazier Tray (If Equipped)**

1. Ensure that boom is retracted and platform fully lowered.
2. Place panel on tray and center it to make sure weight is evenly balanced on the platform.
3. Secure panel in place using the strap provided.

3.8-24 Arctic Weather Package (If Equipped)

**WARNING**

- Do not use heaters if temperature is above freezing.
- Use the correct fluids, and the proper diesel fuel. (refer to Cold Weather Operation Chart)
- At temperatures below -7°C (20°F), run engine at idle for at least 5 minutes before operating aerial platform.

1. Ensure the aerial platform is on level ground, boom is in stowed position and hydraulic oil level is between the minimum and maximum marks on the sight gauge.
2. Locate heater plug (item 1) on engine compartment.
3. Plug heater into a 110V / 15 Amp protected circuit for a minimum of 3 hours.
4. Start engine from base control console (refer to Section 3.8-1).

**WARNING**

**DO NOT** over crank the starter. If engine fails to start after multiple attempts, consult “Troubleshooting Information” in the Service and Maintenance Manual.

**IMPORTANT**

Ensure heater is unplugged before operating aerial platform.

**NOTE**

- If aerial platform is to be parked for an extended period of time, remove the battery and store it in a warm place.
- Refer to the cold weather operation chart (Figure 3-11) to assist in operating the aerial platform in cold weather conditions.

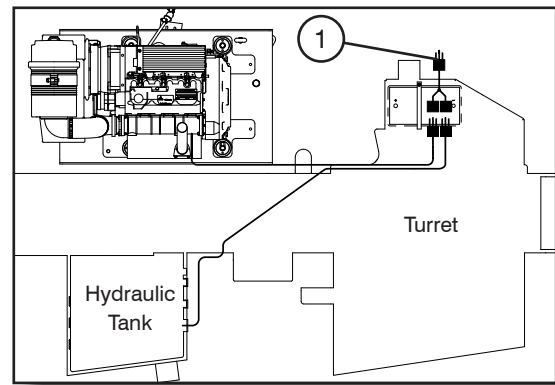

Figure 3-10. Heater Plug

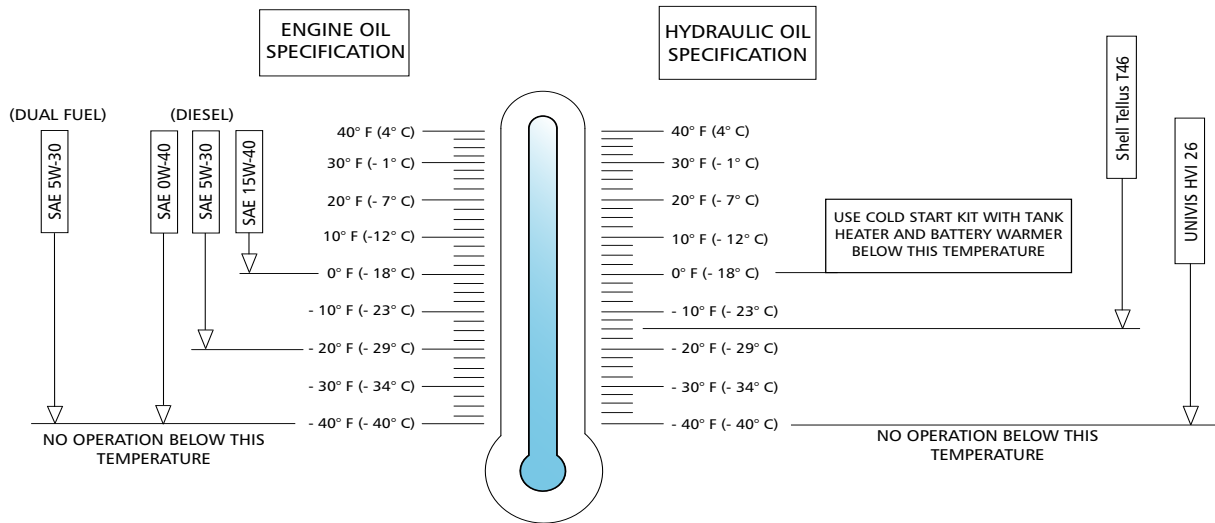

Figure 3-11. Cold Weather Operation Chart

### 3.9 Refueling Procedure

This section provides the operator with procedure on how to refuel engine with regular fuel.



#### **WARNING**

**Failure to heed the following safety precautions could result in death or serious injury:**

- **Use extreme caution while refueling aerial platforms.**
- **Ensure that engine and all systems are turned off before refueling.**
- **Refuel the aerial platform only in a well ventilated area away from open flame and other sources of ignition, authorized by your employer and supervisor.**
- **Never try to start an aerial platform if you smell gasoline or propane.**
- **Gasoline engine models:  
Use only unleaded gasoline with an octane rating 87 or higher.**



#### **WARNING**

**Do not smoke in an area where aerial platforms are stored or refueled.**



#### **CAUTION**

**When operating on a slope, ensure fuel level is above half to avoid a possible stall condition.**

#### **IMPORTANT**

**Before using your aerial platform ensure there is enough fuel for expected use.**

#### 3.9-1 Regular Fuel (Gasoline or Diesel)

#### **IMPORTANT**

**Use unleaded gasoline only.**

1. Ensure engine and all systems are turned off and emergency stop buttons are depressed.
2. Open control compartment and remove fuel cap.
3. Carefully fill the fuel tank ensuring that no spillage occurs.
4. Securely replace fuel cap.
5. Ensure there are no leaks in fuel system.
6. Wipe up any spilled fuel.
7. Dispose of rags in an approved container.

### 3.10 Loading/Unloading

Know and heed all national, state/provincial and local rules which apply to transporting of aerial platforms.

Only qualified personnel shall operate machinery during loading/unloading.

Be sure vehicle capacity and loading equipment hoists, chains, straps, etc., are sufficient to withstand maximum aerial platform weight.

The transport vehicle must be parked on a level surface and must be secured to prevent rolling while aerial platform is being loaded or unloaded.

#### 3.10-1 Loading and Tie-down

1. Lock turret using turret transportation lock (refer to [Section 3.10-2](#)).
2. Turn key switch to “○” off position and remove key before transporting.

3. Turn main power disconnect switch to “○” off position.
4. Chock aerial platform wheels (if necessary).
5. Remove all loose items.
6. Anchor down aerial platform to transport surface using tie-down points (refer to [Figure 3-12](#)).
7. Secure boom from side-to-side movement using lower platform mount between boom end and platform. Do not use excessive downward force when securing boom section.



#### WARNING

**Inspect aerial platform for loose or unsecured items.**

#### NOTE

For loading and unloading using a winch line, refer to [Section 3.10](#).

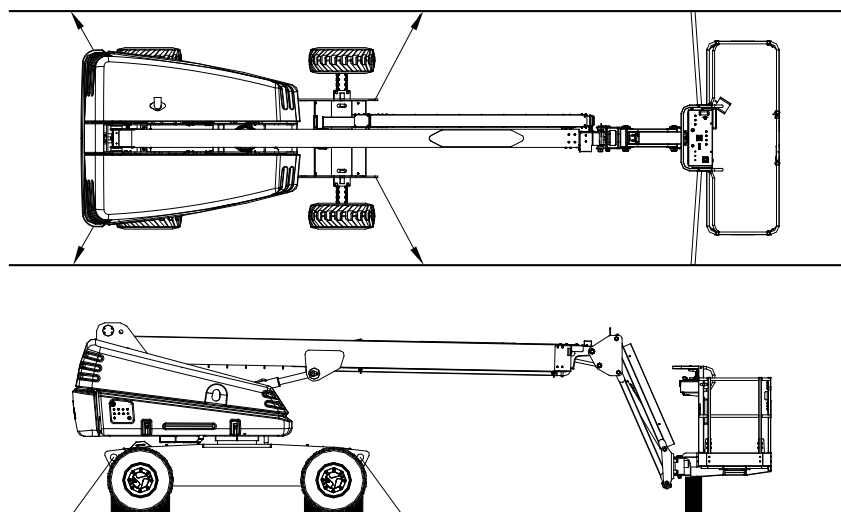

Figure 3-12. Tie-down Points

3.10-2 Locking the Turret

1. Ensure that turret is positioned so that turret transportation lock (item 1 - Figure 3-13) is aligned into one of four turret locking points.
2. Pull out turret lock retaining pin (item 2 - Figure 3-13). Lower turret lock into locked position and reinsert turret lock retaining pin.

3.10-3a Lifting (40T/45T)

1. Place boom in stowed position (boom lowered and fully retracted, jib fully down, if equipped) centered between drive wheels. Lock turret using turret transportation locking pin (refer to Section 3.10-2) into one of two transport/lift points only (refer to Figure 3-13).
2. Turn main power disconnect switch to “○” off position.

3. Clear platform of all personnel, tools and materials.



**WARNING**

When lifting the aerial platform, lifting devices must be attached to designated lift points only (refer to Figure 3-14).



**WARNING**

Use chains with load capacity sufficient to withstand aerial platform weight. Refer to the serial plate of the aerial platform for specific weight.

4. Properly adjust rigging to ensure aerial platform remains level during lifting. See Center of gravity location (Figure 3-14).

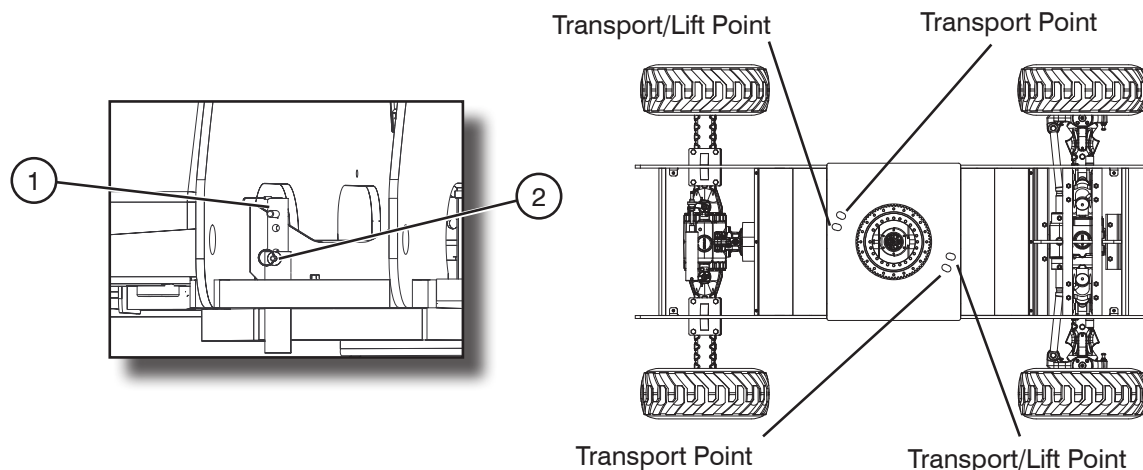

Figure 3-13. 40/45T Turret Transportation Lock & Locking Points

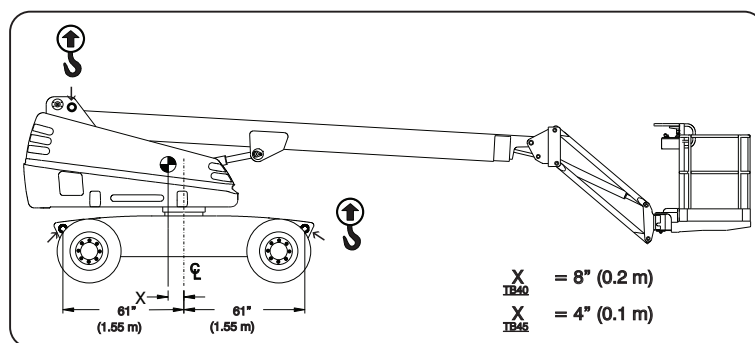

Figure 3-14. 40/45T Lifting Points

3.10-3b Lifting (61T/66T)

1. Rotate the boom and position the aerial platform as shown in Figure 3-15 and Figure 3-16..
2. Turn main power disconnect switch to “○” off position.
3. Clear platform of all personnel, tools and materials.



**WARNING**

**When lifting the aerial platform, lifting devices must be attached to designated lift points only (refer to Figure 3-16 and Figure 3-17).**



**WARNING**

**Use chains with load capacity sufficient to withstand aerial platform weight. Refer to the serial plate of the aerial platform for specific weight.**

4. Properly adjust rigging to ensure aerial platform remains level during lifting. See Center of gravity location (Figure 3-15).

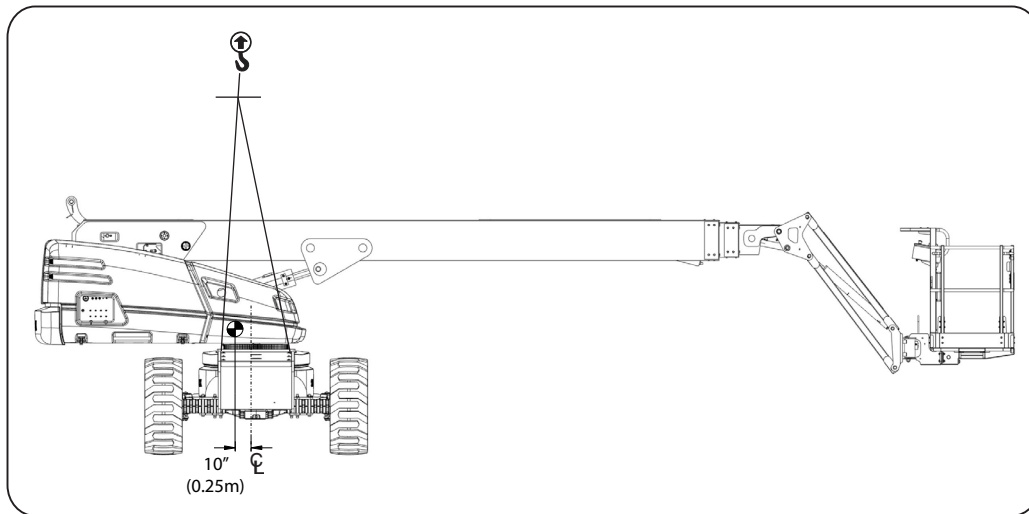

Figure 3-15. 61/66T Center of Gravity

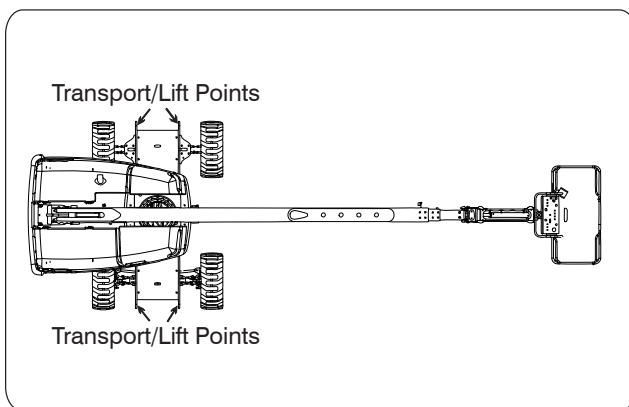

Figure 3-16. 61/66T Overhead View Lifting Points

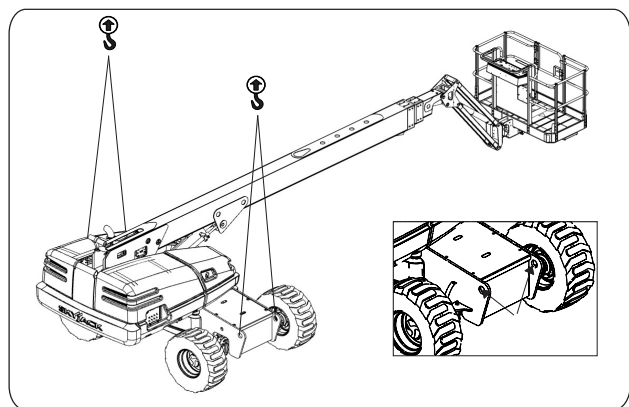

Figure 3-17. 61/66T Lifting Points

### 3.11 Chassis Tilt

This section guides the operator with regard to recovering from an inclined position.

**IMPORTANT**

**When the boom is raised or extended, the aerial platform must only be operated on firm level surfaces.**



**WARNING**

**When the aerial platform becomes tilted causing the alarm to sound, the platform must be fully lowered and retracted immediately. Drive functions are not available when the tilt alarm is active.**

#### 3.11-1 Counterweight Uphill

If the aerial platform becomes tilted with the counterweight uphill (refer to [Figure 3-18](#)) follow the steps below to return to a lowered and retracted position.

1. Retract the fly boom completely
2. Drive to a firm level surface.

#### 3.11-2 Counterweight Downhill

If the aerial platform becomes tilted with the counterweight downhill (refer to [Figure 3-19](#)) follow the steps below to return to a lowered and retracted position.

1. Lower the jib to horizontal (if equipped).
2. Retract the fly boom completely.
3. Lower the main boom completely.
4. Drive to a firm level surface.

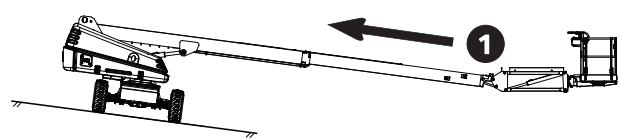
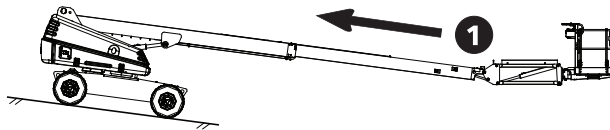

Figure 3-18. Counterweight Uphill

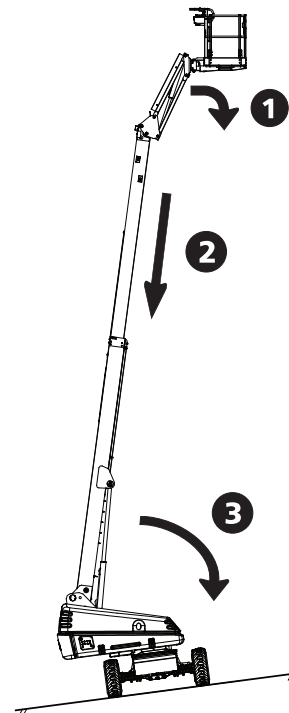
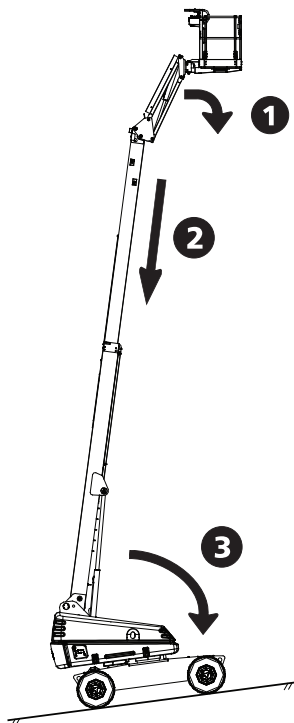

Figure 3-19. Counterweight Downhill

Diagram 3.1 Dimension and Reach Diagram - SJ 40T

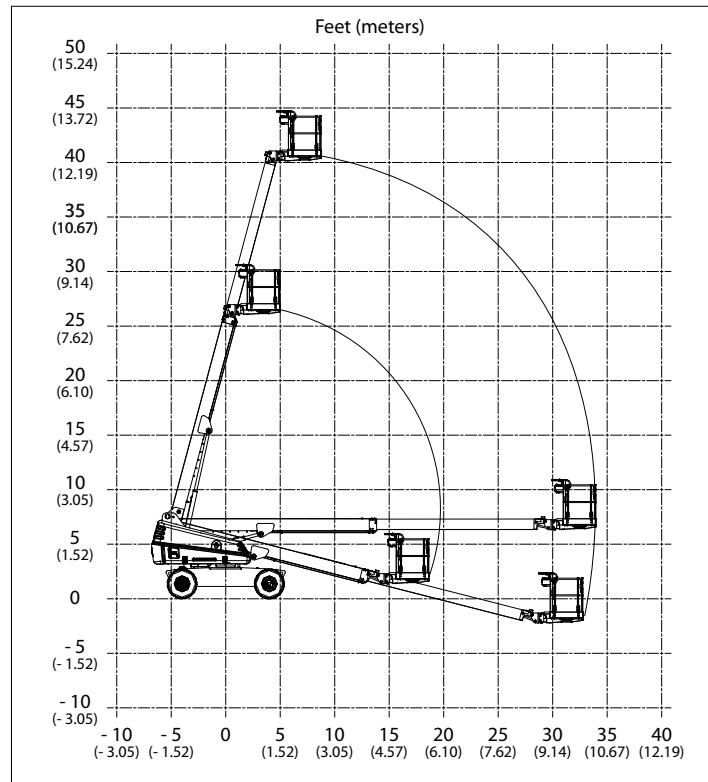

Figure 3-20. Reach Diagram - 40T

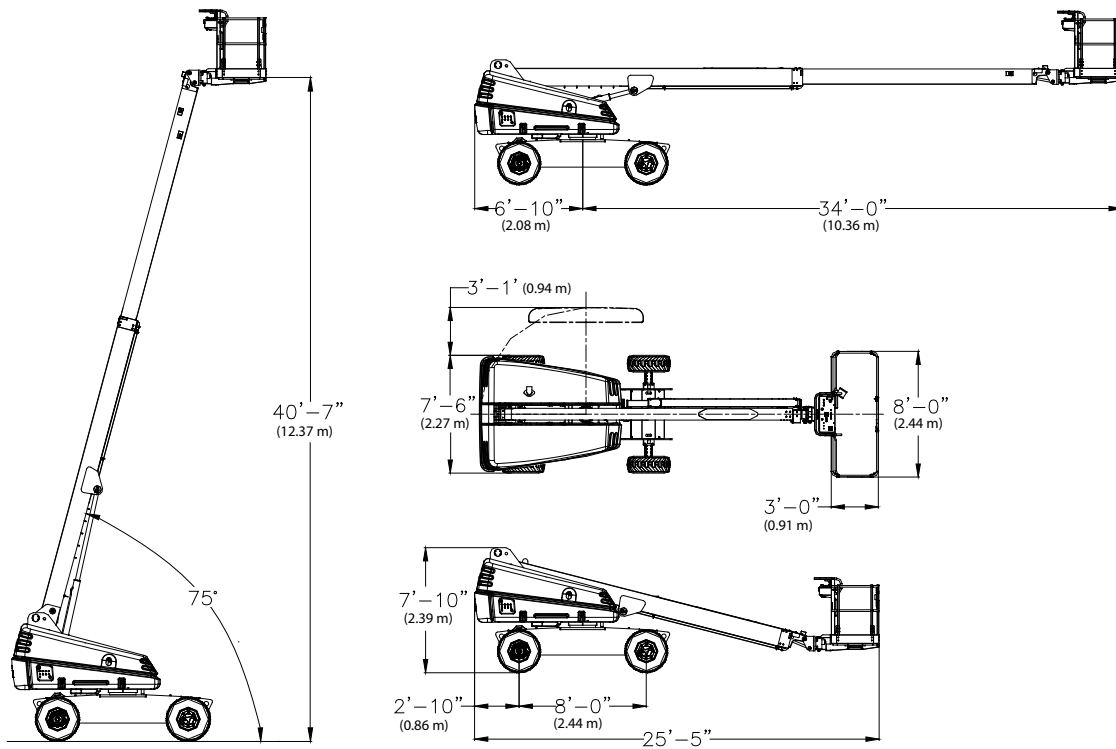

Figure 3-21. Dimension - 40T

Diagram 3.2 Dimension and Reach Diagram - SJ 45T

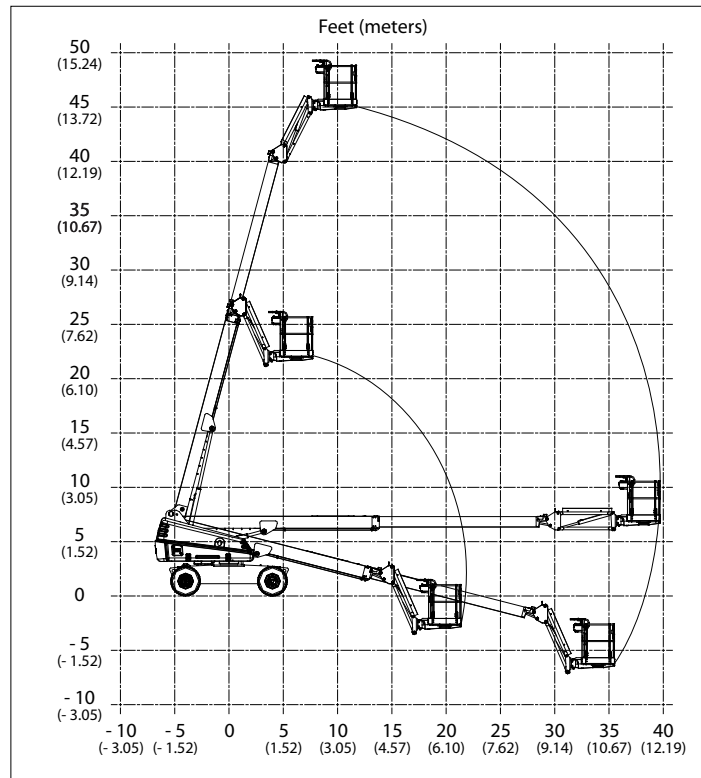

Figure 3-22. Reach Diagram - 45T

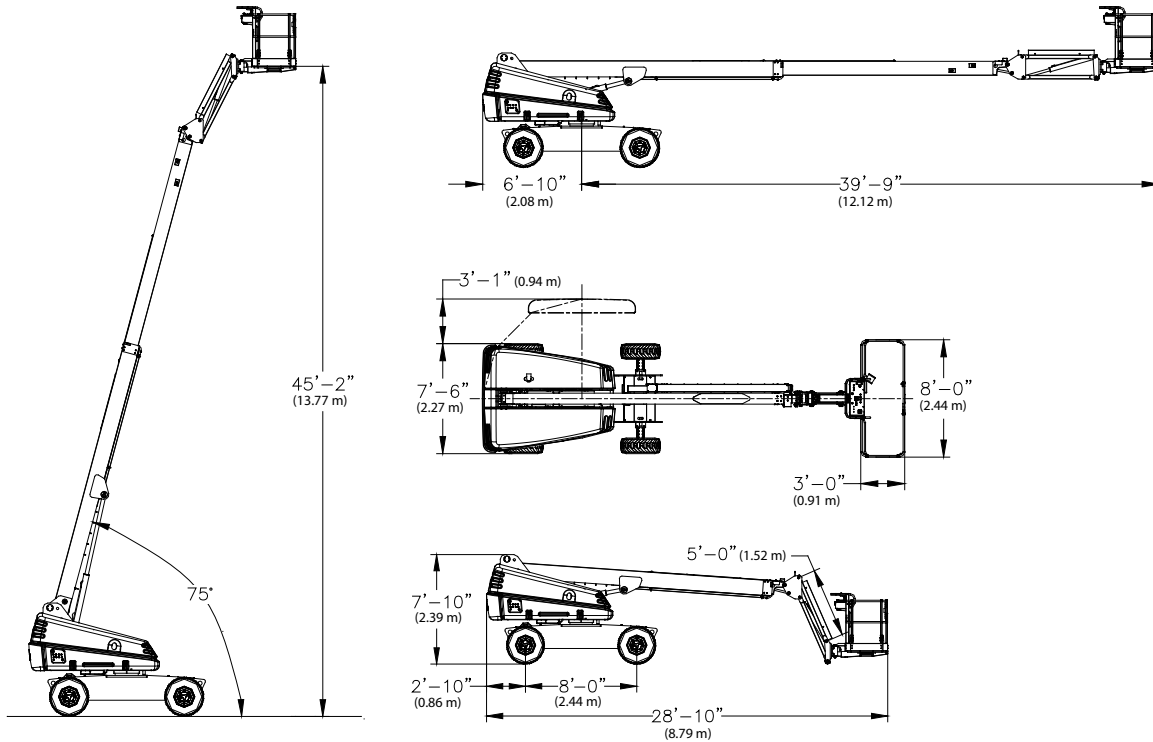

Figure 3-23. Dimensions - 45T

Diagram 3.3 Dimension and Reach Diagram - SJ 61T

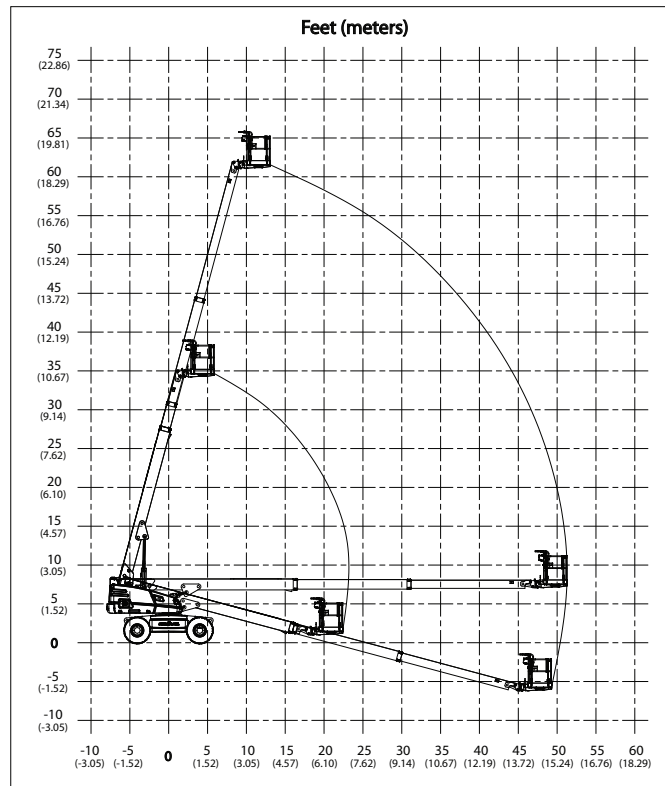

Figure 3-24. Reach Diagram - 61T

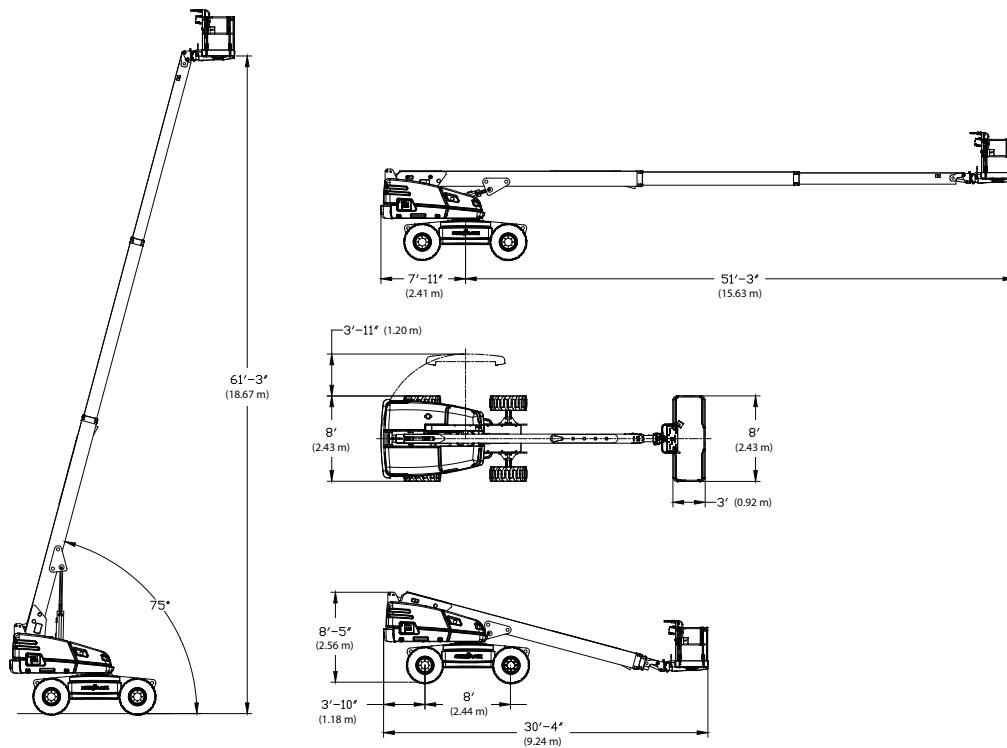

Figure 3-25. Dimension - 61T

Diagram 3.4 Dimension and Reach Diagram - SJ 66T

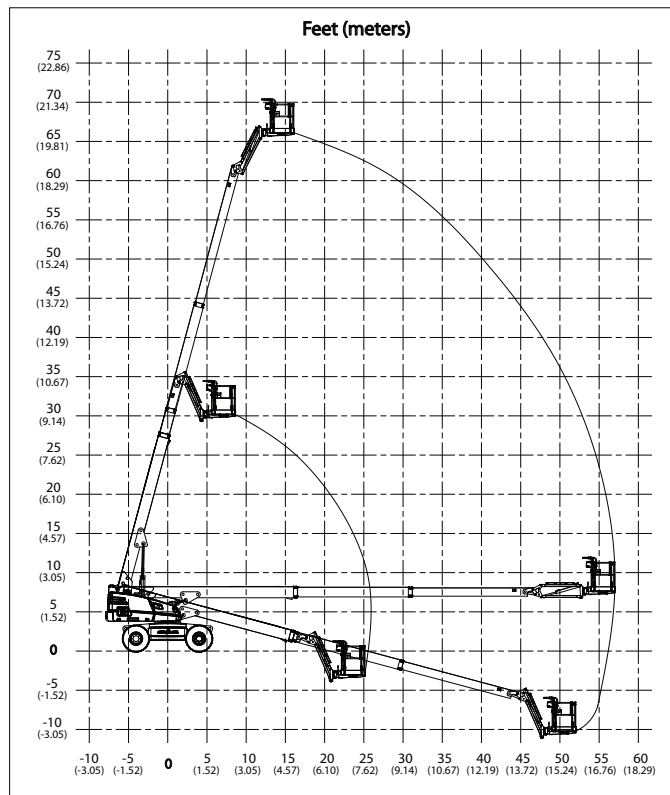

Figure 3-26. Reach Diagram - 66T

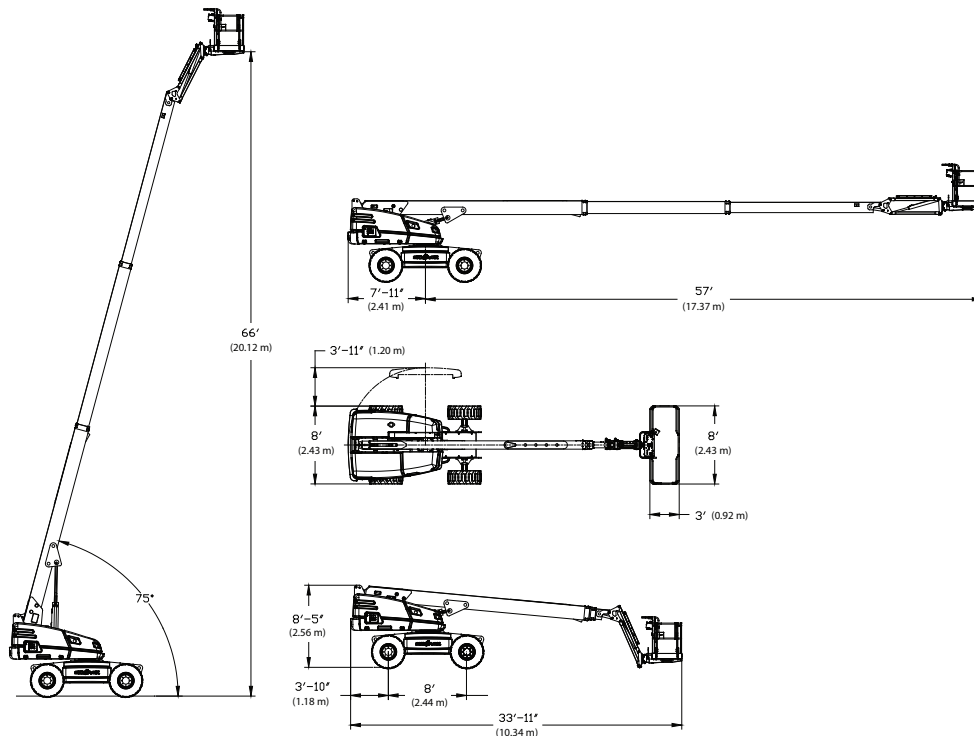

Figure 3-27. Dimensions - 66T

Diagram 3.5 Axle Oscillation Diagrams



**WARNING**

**Do not raise the platform in work mode if it is not on a firm level surface.**

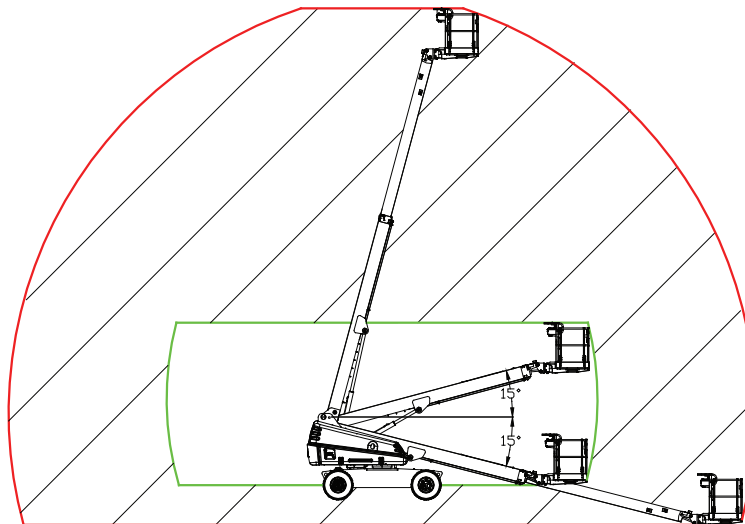



-  Axle oscillation free (travel mode) - drive speed 4.5 mph (7.2 km/h) max.
-  Axle oscillation locked (work mode) - drive speed 0.5 mph (0.8 km/h) max.

Figure 3-28. Axle Oscillation - SJ 40T/61T



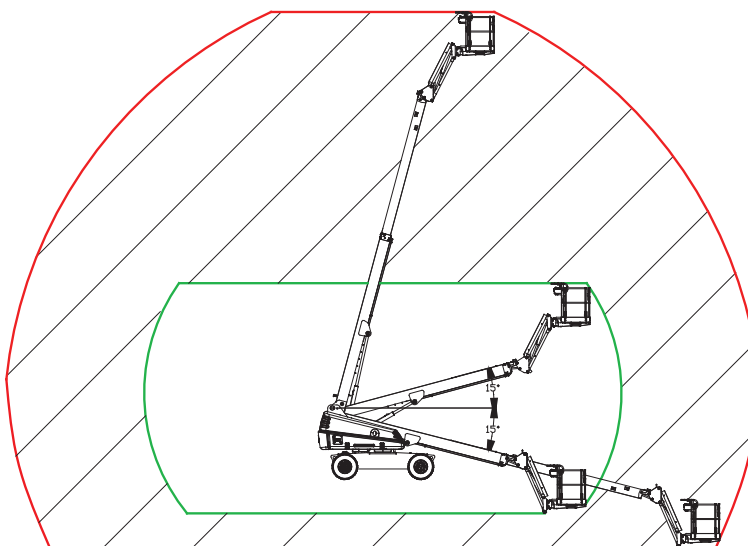

-  Axle oscillation free (travel mode) - drive speed 4.5 mph (7.2 km/h) max.
-  Axle oscillation locked (work mode) - drive speed 0.5 mph (0.8 km/h) max.

Figure 3-29. Axle Oscillation - SJ 45T/66T



Table 4.1 Standard and Optional Features

MODEL	SJ 40T	SJ 45T	SJ 61T	SJ 66T
<b>STANDARD EQUIPMENT</b>				
Platform controls	✓	✓	✓	✓
Base controls	✓	✓	✓	✓
Four-wheel drive	✓	✓	✓	✓
Oscillating axle (steer)	✓	✓	✓	✓
Side entry spring hinged gate	✓	✓	✓	✓
Variable speed drive and function controls	✓	✓	✓	✓
Continuous drive and steer directional sensing	✓	✓	✓	✓
12 Volt DC emergency power	✓	✓	✓	✓
Engine anti-restart protection	✓	✓	✓	✓
Glow plug heaters (diesel only)	✓	✓	✓	✓
Spring-applied hydraulically released parking brake	✓	✓	✓	✓
110V outlet on platform with GFI	✓	✓	✓	✓
Diesel engine	✓	✓	✓	✓
Operator horn	✓	✓	✓	✓
All function motion alarm	✓	✓	✓	✓
Manual brake release	✓	✓	✓	✓
Air-filled tires	✓	✓	✓	✓
5-foot jib	Not Applicable	✓	Not Applicable	✓
<b>OPTIONAL EQUIPMENT</b>				
GM 3.0L dual fuel engine (gas/propane)	✓	✓	✓	✓
Two-wheel drive	✓	✓	✓	✓
Welder package with 12kW hydraulic generator	✓	✓	✓	✓
3500W hydraulic generator	✓	✓	✓	✓
Cold weather start kit (diesel or dual fuel)	✓	✓	✓	✓
Flashing amber light	✓	✓	✓	✓
Platform work light	✓	✓	✓	✓
Base driving light	✓	✓	Not Available	Not Available
Glazier package	✓	✓	✓	✓
Air line or hydraulic line to platform	✓	✓	✓	✓
72 x 36 inch platform	✓	✓	✓	✓
Extra propane tank	✓	✓	✓	✓
Tire sealant	✓	✓	✓	✓
Oil cooler (included with generators)	✓	✓	✓	✓
Foam filled tires	✓	✓	✓	✓
High flotation tires	✓	✓	✓	✓
Diesel scrubber (Level 1)	✓	✓	✓	✓
Diesel scrubber (Level 2)	Not Available	Not Available	✓	✓
Positive Air Shutoff	✓	✓	✓	✓

60551AI-ANSI

4

Table 4.2a Specifications and Features

MODEL		SJ 40T	SJ 45T	SJ 61T	SJ 66T
Maximum Load Capacity		650 lb (295 kg)	500 lb (227 kg)	500 lb (227 kg)	500 lb (227 kg)
Platform Size	Total Platform Length (Outside)	96 in. (243.8 cm)	96 in. (243.8 cm)	96 in. (243.8 cm)	96 in. (243.8 cm)
	Total Platform Depth (Outside)	36 in. (91.4 cm)	36 in. (91.4 cm)	36 in. (91.4 cm)	36 in. (91.4 cm)
Height	Working	46.5 ft. (14.2 m)	51 ft. (15.6 m)	68 ft. (20.6 m)	72.3 ft. (22.0 m)
	Platform Elevated	40 ft. (12.4 m)	45 ft. (13.8 m)	61 ft. (18.8 m)	66 ft. (20.2 m)
	Drive	driveable at all heights		driveable at all heights	
	Turret	7 ft. 10 in. (2.4 m)	7 ft. 10 in. (2.4 m)	8 ft. 6 in. (2.6 m)	8 ft. 6 in. (2.6 m)
Length	Overall with platform	25 ft. 5 in. (7.7 m)	28 ft. 11.5 in. (8.83 m)	30 ft. 4 in. (9.2 m)	34 ft. 2 in. (10.4 m)
	Base and tires	12 ft. 3 in. (3.7 m)	12 ft. 3 in. (3.7 m)	11 ft. 5 in. (3.5 m)	11 ft. 5 in. (3.5 m)
Width	Outside std. tires	7 ft. 6 in. (2.3 m)	7 ft. 6 in. (2.3 m)	8 ft. (2.4 m)	8 ft. (2.4 m)
	Turret	7 ft. 4 in. (2.2 m)	7 ft. 4 in. (2.2 m)	7 ft. 6 in. (2.3 m)	7 ft. 6 in. (2.3 m)
Weight	Weight (with air tires)	14,100 lb. (6,400 kg)	14,815 lb. (6,720 kg)	23,500 lb. (10,650 kg)	26,700 lb. (12,100 kg)
	Weight (with foam-filled tires)	14,900 lb. (6,760 kg)	15,615 lb. (7,085 kg)	25,000 lb. (11,340 kg)	28,200 lb. (12,790 kg)
Platform Rotation		170 degrees	175 degrees	170 degrees	175 degrees
Horizontal Reach		34 ft. (10.34 m)	39 ft. 8 in. (12.1 m)	51 ft. 3 in. (15.6 m)	57 ft. (17.4 m)
Wheelbase		8 ft. (2.4 m)	8 ft. (2.4 m)	8 ft. (2.4 m)	8 ft. (2.4 m)
Turret Rotation		360 degrees continuous		360 degrees continuous	
Turret Tailswing		44 in. (1.12 m)	44 in. (1.12 m)	52.5 in. (1.33 m)	52.5 in. (1.33 m)
Gradeability (torque equivalent to)		50%		50%	
Ground Clearance Between Wheels		11 in. (28 cm)	11 in. (28 cm)	16 in. (41 cm)	16 in. (41 cm)
Turning Radius	Inside	2WD	7 ft. 4 in. (2.2 m)	7 ft. 4 in. (2.2 m)	6 ft. 4 in. (1.9 m)
		4WD	9 ft. (2.7 m)	9 ft. (2.7 m)	9 ft. 3 in. (2.8 m)
	Outside	2WD	17 ft. (5.2 m)	17 ft. (5.2 m)	16 ft. 7 in. (5.0 m)
		4WD	18 ft. 7 in. (5.7 m)	18 ft. 7 in. (5.7 m)	16 ft. 7 in. (5.0 m)
System Voltage		12 VDC		12 VDC	
Battery	Type	Lead Acid		Lead Acid	
	Cold Cranking Amperes	800 A		800 A	
Operating Times	Main boom up	27 - 33 seconds (approx.)		50 - 56 seconds (approx.)	
	Main boom down	27 - 33 seconds (approx.)		50 - 56 seconds (approx.)	
	Fly boom extend	27 - 33 seconds (approx.)		62 - 68 seconds (approx.)	
	Fly boom retract	27 - 33 seconds (approx.)		37 - 43 seconds (approx.)	
	Jib up	18 - 28 seconds (approx.)		18 - 28 seconds (approx.)	
	Jib down	10 - 16 seconds (approx.)		10 - 16 seconds (approx.)	
	Turret rotate - counterclockwise 360° (fully stowed)	80 - 110 seconds (approx.)		90 - 110 seconds (approx.)	
	Platform rotate - full	5 - 9 seconds (approx.)		5 - 9 seconds (approx.)	
Driving Speeds	Drive Speed (maximum-stowed)	4.5 mph (7.2 km/h)		4.5 mph (7.2 km/h)	
	Drive Speed (maximum-elevated)	0.5 mph (0.8 km/h)		0.5 mph (0.8 km/h)	





60629AE-ANSI

Table 4.2b Specifications and Features

MODEL				SJ 40T	SJ 45T	SJ 61T	SJ 66T	
Engine - Deutz	Engine Type			Deutz D2.9		Deutz TD2.9		
	Fuel Type			Diesel				
	Fuel Tank Capacity			45 gal (170.3 L)				
	Standard Oil Factory Fill	Ambient Temperature Limits	0°F to 115°F (-18°C to +45°C)	SAE 15W-40 API CF/CG/CH-4				
	Cold Lube Oil Option		-20°F to 90°F (-29°C to +32°C)	SAE 5W-30 API CF/CG/CH-4				
	Arctic Lube Oil Option		-40°F to 115°F (-40°C to +45°C)	SAE 0W-40 API CF/CG/CH-4				
	Approved Alternates			See Engine Manual				
	Lube Oil Sump Capacity			2.11 gal (8 L)		2.38 gal (9 L)		
	Radiator Capacity			2.38 gal (9 L)		3.43 gal (13L)		
	Radiator Fluid Type			DELO ELC 50/50				
Engine - Deutz	Engine Type			Deutz D2011L03i		Deutz D2011L04i		
	Fuel Type			Diesel				
	Fuel Tank Capacity			45 gal (170.3 L)				
	Standard Oil Factory Fill	Ambient Temperature Limits	0°F to 115°F (-18°C to +45°C)	SAE 15W-40 API CF/CG/CH-4				
	Cold Lube Oil Option		-20°F to 90°F (-29°C to +32°C)	SAE 5W-30 API CF/CG/CH-4				
	Arctic Lube Oil Option		-40°F to 115°F (-40°C to +45°C)	SAE 0W-40 API CF/CG/CH-4				
	Approved Alternates			See Engine Manual				
	Lube Oil Sump Capacity			1.45 gal (5.5 L)		2.64 gal (10.0 L)		
	Engine - GM	Engine Type			3.0L GM Dual Fuel			
		Fuel Type - Dual			Gasoline/Propane			
Fuel Tank Capacity			45 gal (170.3 L)					
Standard Oil Factory Fill		Ambient Temperature Limits	-40°F to 115°F (-40°C to +45°C)	SAE 5W-30 API SL				
Approved Alternates				See Engine Manual				
Lube Oil Capacity			1.19 gal (4.5 L)					
Standard Coolant		Ambient Temperature Limits	-20°F to 115°F (-29°C to +45°C)	GM 50/50 Extended Life Coolant				
Arctic Coolant Option			-40°F to 115°F (-40°C to +45°C)	GM 60/40 Extended Life Coolant				
Coolant Capacity			3.0 gal (11.4 L)					
Engine - Kubota		Engine Type			2.5L Kubota Dual Fuel			
	Fuel Type - Dual			Gasoline/Propane				
	Fuel Tank Capacity			45 gal (170.3 L)				
	Standard Oil Factory Fill	Ambient Temperature Limits	-40°F to 115°F (-40°C to +45°C)	SAE 5W-30 API SL				
	Approved Alternates			See Engine Manual				
	Lube Oil Capacity			2.5 gal (9 L)				
	Standard Coolant	Ambient Temperature Limits	-20°F to 115°F (-29°C to +45°C)	Recochem 50/50 Extended Life Coolant				
	Arctic Coolant Option		-40°F to 115°F (-40°C to +45°C)	Recochem 60/40 Extended Life Coolant				
	Coolant Capacity			3.17 gal (12 L)				
	Hydraulic Oil	Hyd Cooler Option	Ambient Temperature Limits	100°F to 115°F (+38°C to +45°C)	Oil cooler option recommended			
Standard Factory Fill		-15°F to 100°F (-26°C to +38°C)		Shell Tellus T46				
Arctic Oil Option		-40°F to 100°F (-40°C to +38°C)		Esso/Mobil UNIVIS HVI 26 Petro-Canada HYDREX EXTREME				
Approved Alternates		-15°F to 100°F (-26°C to +38°C)		Mobilfluid 424, Esso UNIVIS N46, Chevron Ryon MV				
		-40°F to 80°F (-40°C to +27°C)		Mobil DTE 13M, Esso UNIVIS N22 Petro-Canada HYDREX MV Arctic 15				
Hydraulic Tank Capacity				59 gal (223.3 L)				

60628AG-ANSI

Table 4.3 Owner’s Annual Inspection Record

										
 <b>Model Number:</b> _____ <b>Serial Number:</b> _____										
*		20__	20__	20__	20__	20__	20__	20__	20__	20__
**										

1000AB

This decal is located on the control compartment cowling. It must be completed after an annual inspection has been completed. Do not use the aerial platform if an inspection has not been recorded in the last 13 months.



	Pictorial	Description
*		Inspection Date
**		Inspector Signature

Table 4.4 Maximum Platform Capacities

	SJ 40T	SJ 45T	SJ 61T	SJ 66T
Total Capacity	650 lb. (295 kg)	500 lb. (227 kg)	500 lb. (227 kg)	500 lb. (227 kg)
	2 Persons	2 Persons	2 Persons	2 Persons
Maximum Wind	28 mph(12.5 m/s)	28 mph(12.5 m/s)	28 mph(12.5 m/s)	28 mph(12.5 m/s)
Maximum Side Force	90 lbf (400 N)	90 lbf (400 N)	90 lbf (400 N)	90 lbf (400 N)

1062AB\_ANSI

Table 4.5 Tire/Wheel Specifications

	SJ 40T/45T	SJ 61T/66T
Tire Size	12" x 16.5" (30.5 cm x 41.9 cm)	15" x 19.5" (38.1 cm x 49.5 cm)
Pressure	65 psi (448.2 kPa)	95 psi (655 kPa)
Tire Ply Rating	10	16
Wheel Nuts Torque	290 ft-lb (393.2 Nm)	290 ft-lb (393.2 Nm)

60565AD-ANSI

**WARNING**

**Intermixing tires of different types or using tires of types other than those originally supplied with this equipment can adversely affect stability. Therefore, replace tires only with the exact Skyjack-approved type. Failure to operate with matched approved tires in good condition may result in death or serious injury.**

Table 4.6 Floor Loading Pressure

MODEL (with Air Filled Tires)	Gross Aerial Platform Weight		Total Aerial Platform Load					
			Wheel		LCP		OUP	
	lb.	kg	lb.	kg	psi	kPa	psf	kPa
SJ 40T	14,750	6,695	7,600	3,450	130	900	193	9.3
SJ 45T	15,315	6,950	8,000	3,630	135	930	200	9.5
SJ 61T	24,000	10,890	12,360	5,600	145	1000	330	15.8
SJ 66T	27,200	12,340	13,900	6,300	165	1140	372	17.8

MODEL (with Foam Filled Tires)	Gross Aerial Platform Weight		Total Aerial Platform Load					
			Wheel		LCP		OUP	
	lb.	kg	lb.	kg	psi	kPa	psf	kPa
SJ 40T	15,550	7,055	7,600	3,450	130	900	193	9.3
SJ 45T	16,115	7,310	8,000	3,630	135	930	200	9.5
SJ 61T	25,500	11,567	12,360	5,600	145	1000	330	15.8
SJ 66T	28,700	13,018	13,900	6,300	165	1140	372	17.8

60562AH-ANSI

- Gross Aerial Platform Weight = Weight + platform capacity
- LCP – Locally Concentrated Pressure – is a measure of how hard the aerial platform tire tread presses on the area in direct contact with the floor. The floor covering (tile, carpet, etc.) must be able to withstand more than the indicated values above.
- OUP – Overall Uniform Pressure – is a measure of the average load the aerial platform imparts on the whole surface projected directly underneath it. The structure of the operating surface (beams, etc.) must be able to withstand more than the indicated values above.
- Welder option will add approximately 350 lb. (158.8 kg) to total aerial platform weight and 175 lb. (79.4 kg) to max. wheel load.

**NOTE:**

The LCP or OUP that an individual surface can withstand varies from structure to structure and is generally determined by the engineer or architect for that particular structure.

**Locally Concentrated Pressure (LCP):**

Foot Print Area identified by test.

$$LCP = \frac{\text{Wheel Load}}{\text{Foot Print Area}}$$

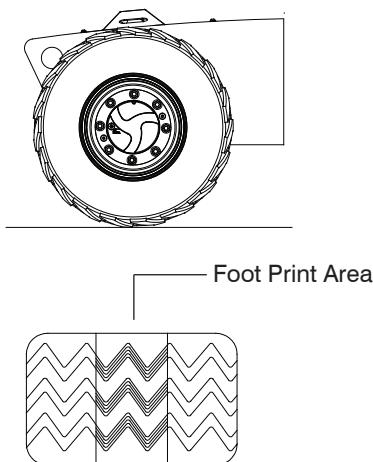

**Overall Uniform Pressure (OUP):**

Base Area = Length x Width

$$OUP = \frac{\text{Aerial Platform Weight} + \text{Capacity}}{\text{Base Area}}$$

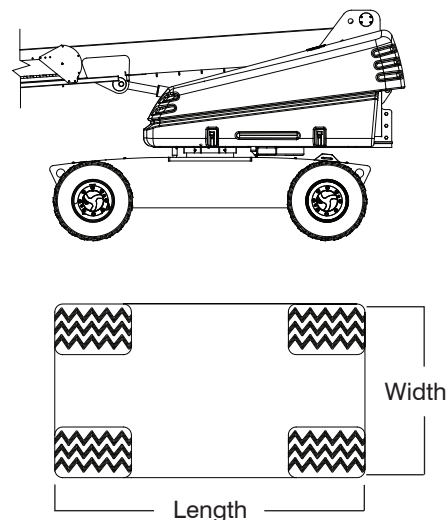

**General Maintenance**

Before attempting any repair work, disconnect battery by turning main power disconnect switch to “○” off position. Preventive maintenance is the easiest and least expensive type of maintenance.

**Table 4.7 Maintenance and Inspection Schedule**

Frequency	Daily	3 months or 150 hours	Yearly	Frequency	Daily	3 months or 150 hours	Yearly	
<b>Visual and Daily Maintenance Inspections</b>				<b>Rotary Actuator</b>				A
Labels	A			<b>Jib (If Equipped)</b>	A			
Electrical	A			<b>Boom</b>	A			
Limit Switches	A			Cylinders	A			
Hydraulic	A			Wear Pads	A			
<b>Engine Compartment</b>				Hoses	A			
Main Power Disconnect Switch	A			Power Track	A			
Battery	A			Cables (61T/66T)	A			
Swing Drive Motor	A			<b>Optional Equipment/Attachments</b>				
Turret Rotation Gear	A			Hydraulic Generator (If Equipped)	A			
Rotary Manifold	A			Battery Warmer/Hydraulic Oil Heater (If Equipped)	A			
High Pressure Filter (40T/45T)	A			Welder (If Equipped)	A			
Hydraulic Pumps	A			Work Light (If Equipped)	A			
Muffler and Exhaust	A			Flashing Amber Light (If Equipped)	A			
Engine Pivot Tray	A			Glazier Tray (If Equipped)	A			
Engine Oil Level	A			Arctic Weather Package (If Equipped)	A			
Engine Air Filter	A			<b>Function Tests</b>				
Fuel Leaks	A			<b>Test Main Power Disconnect Switch</b>	A			
<b>Control Compartment</b>				<b>Base Control Console</b>				
Base Control Console	A		B*†	Test Emergency Stop	A			
Hydraulic Tank	A			Test Function Enable Switch & All Boom Functions	A			
Hydraulic Oil	A			Test Platform Self-leveling	A			
Hydraulic Return Filter	A			Test Emergency Power	A			
Brake and Main Manifolds	A			Test Base/Off/Platform Switch	A			
Emergency Power Unit	A			Test Positive Air Shutoff (If Equipped)	A			
Fuel Tank	A			<b>Platform Control Console</b>				
Fuel Leaks	A			Test Footswitch	A			
<b>Base</b>				Test Emergency Stop	A			
Turret Transportation Lock	A			Test Steering	A			
Drive Axle	A			Test Driving Function	A			
Oscillating Cylinder Assembly	A			Test Driving Speed	A			
Steer Cylinder Assembly	A			Test Emergency Power	A			
Tie Rod	A			Test Horn	A			
Wheel/Tire Assembly	A			Test Brakes	A			
<b>Manuals</b>	A			Test Manual Platform Leveling	A			
<b>Platform Assembly</b>	A			Test Differential Lock Switch	A			
<b>Platform Control Console</b>	A			Test Oscillating Axles	A			
				Test Cables (61T/66T)	A			

60559AL-ANSI

**A** - Perform Visual and Daily Maintenance Inspections & Functions Test. Refer to Section 2.3 and Section 2.4 of this manual.

**B** - Perform Scheduled Maintenance Inspection. Refer to Service & Maintenance manual.

\* - Maintenance must be performed only by trained and competent personnel who are familiar with mechanical procedures.

† - Refer to Skyjack's website @ [www.skyjack.com](http://www.skyjack.com) for latest service bulletins prior to performing quarterly or yearly inspection.



**WARNING**

**Use original or manufacturer-approved parts and components for aerial platform.**

Table 4.8 Operator's Checklist



Serial Number: \_\_\_\_\_  
 Model: \_\_\_\_\_  
 Hourmeter Reading: \_\_\_\_\_  
 Date: \_\_\_\_\_  
 Time: \_\_\_\_\_

Operator's Name (Printed): \_\_\_\_\_

Operator's Signature: \_\_\_\_\_

Each item shall be inspected using the appropriate section of the Skyjack operating manual. As each item is inspected, check the appropriate box.

- P** - PASS
- F** - FAIL
- R** - REPAIRED
- NA** - NOT APPLICABLE

**INSPECTION FREQUENCY**

- DAILY
- FREQUENTLY
- ANNUALLY
- BI-ANNUALLY

	N/A	P	F	R
<b>Visual and Daily Maintenance Inspections</b>				
<b>Labels</b>				
<b>Electrical</b>				
<b>Limit Switches</b>				
<b>Hydraulic</b>				
<b>Engine Compartment</b>				
Main Power Disconnect Switch				
Battery				
Swing Drive Motor				
Turret Rotation Gear				
Rotary Manifold				
High Pressure Filter (40T/45T)				
Hydraulic Pumps				
Muffler and Exhaust				
Engine Pivot Tray				
Engine Oil Level				
Engine Air Filter				
Fuel Leaks				
<b>Control Compartment</b>				
Base Control Console				
Hydraulic Tank				
Hydraulic Oil				
Hydraulic Return Filter				
Brake and Main Manifolds				
Emergency Power Unit				
Fuel Tank				
Fuel Leaks				
<b>Base</b>				
Turret Transportation Lock				
Drive Axle				
Oscillating Cylinder Assembly				
Steer Cylinder Assembly				
Tie Rod				
Wheel/Tire Assembly				
<b>Manuals</b>				
<b>Platform Assembly</b>				
<b>Platform Control Console</b>				

	N/A	P	F	R
<b>Rotary Actuator</b>				
<b>Jib (If Equipped)</b>				
<b>Boom</b>				
Cylinders				
Wear Pads				
Hoses				
Power Track				
Cables (61T/66T)				
<b>Optional Equipment/Attachments</b>				
Hydraulic Generator (If Equipped)				
Battery Warmer/Hydraulic Oil Heater (If Equipped)				
Welder (If Equipped)				
Work Light (If Equipped)				
Flashing Amber Light (If Equipped)				
Glazier Tray (If Equipped)				
Arctic Weather Package (If Equipped)				
<b>Function Tests</b>				
<b>Test Main Power Disconnect Switch</b>				
<b>Base Control Console</b>				
Test Emergency Stop				
Test Function Enable Switch & All Boom Functions				
Test Platform Self-leveling				
Test Emergency Power				
Test Base/Off/Platform Switch				
Test Positive Air Shutoff (If Equipped)				
<b>Platform Control Console</b>				
Test Footswitch				
Test Emergency Stop				
Test Steering				
Test Driving Function				
Test Driving Speed				
Test Emergency Power				
Test Horn				
Test Brakes				
Test Manual Platform Leveling				
Test Differential Lock Switch				
Test Oscillating Axles				
Test Cables (61T/66T)				

60560AL-ANSI

**Note:**  
 Make a copy of this page or visit the Skyjack web site:  
[www.skyjack.com](http://www.skyjack.com) for a printable copy.

### Label Legend



A red horizontal bar at the top of a white rounded rectangle contains a warning triangle icon and a book icon. Below the bar, the text reads "Safety Red indicates DANGER." An arrow points from the text "Safety Red" to the red bar.

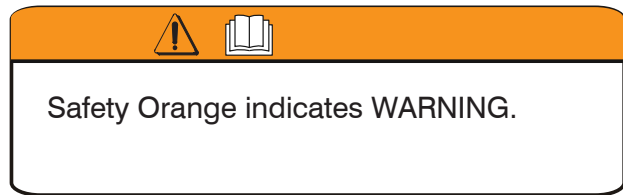

An orange horizontal bar at the top of a white rounded rectangle contains a warning triangle icon and a book icon. Below the bar, the text reads "Safety Orange indicates WARNING." An arrow points from the text "Safety Orange" to the orange bar.

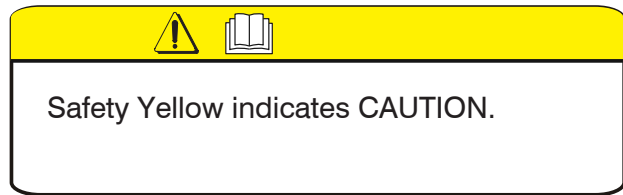

A yellow horizontal bar at the top of a white rounded rectangle contains a warning triangle icon and a book icon. Below the bar, the text reads "Safety Yellow indicates CAUTION." An arrow points from the text "Safety Yellow" to the yellow bar.

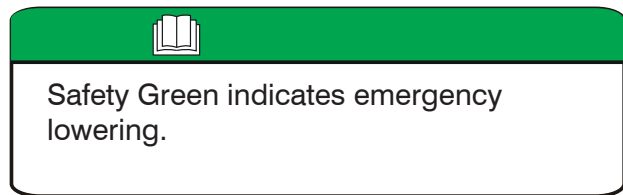

A green horizontal bar at the top of a white rounded rectangle contains a book icon. Below the bar, the text reads "Safety Green indicates emergency lowering." An arrow points from the text "Safety Green" to the green bar.



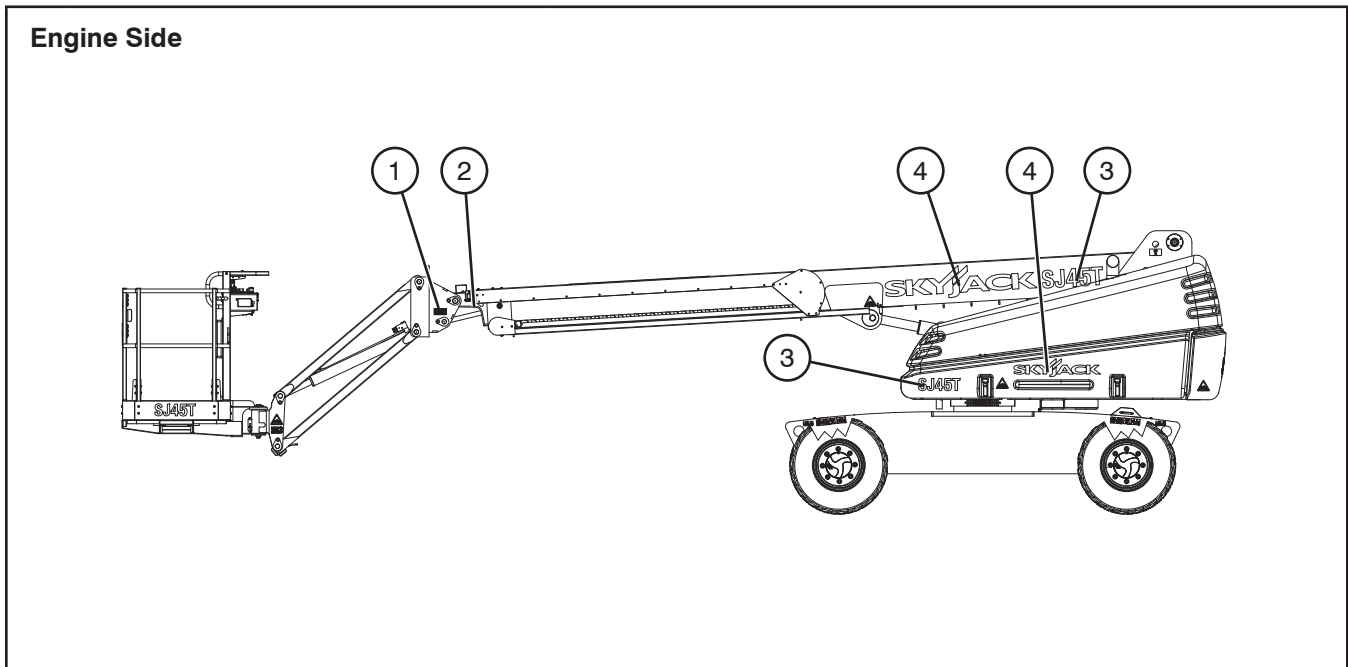

A blue horizontal bar at the top of a white rounded rectangle contains a book icon. Below the bar, the text reads "Safety Blue indicates safety information." An arrow points from the text "Safety Blue" to the blue bar.

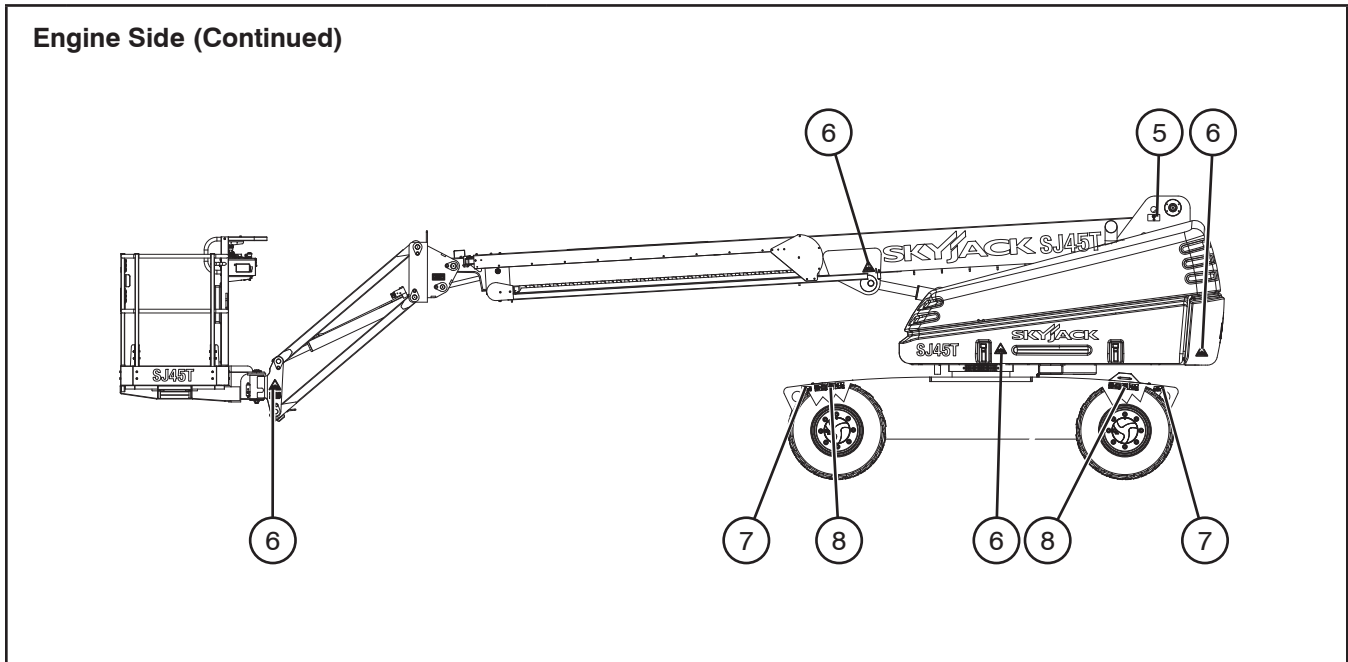

No.	Label Pictorial	Description
1		<p><b>Crushing Hazard</b></p> <p>Danger - Crushing hazard</p>
2		<p><b>Warning - Do Not Alter</b></p> <p>Do not alter or disable limit switches or other safety devices.</p>
3		<p><b>Model Number*</b></p> <p>Product Identifier *Model number will vary, may not be as shown.</p>
4		<p><b>Skyjack Logo</b></p> <p>Skyjack</p>

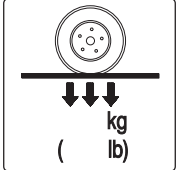

No.	Label Pictorial	Description
5		<p><b>Lift Points</b></p> <p>Only use these points for lifting.</p>
6		<p><b>Body Crushing Hazard</b></p> <p>Danger - Body crushing hazard</p>
7		<p><b>Lift and Tie Down Points</b></p> <p>Only use these points for lifting or tying down.</p>
8		<p><b>Wheel Load*</b></p> <p>Indicates rated wheel load. *Wheel load will vary over different aerial platforms.</p>

Engine Side (Continued)

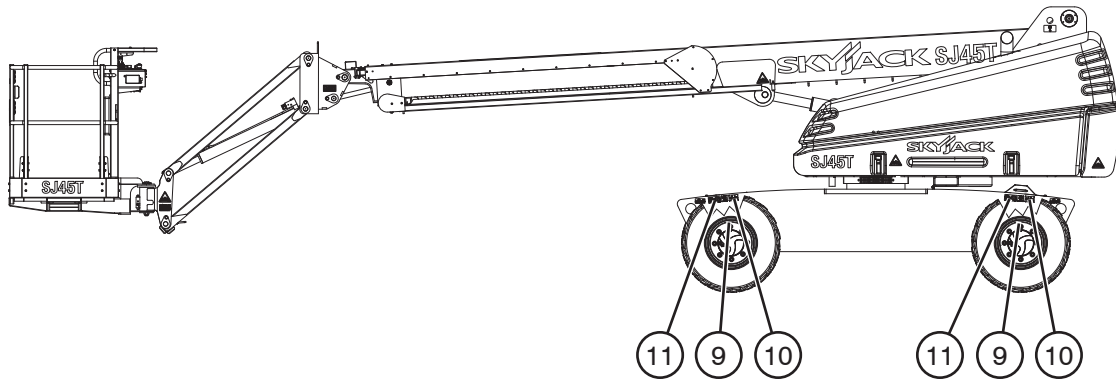

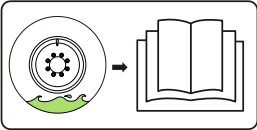
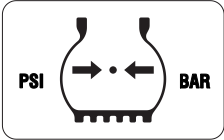
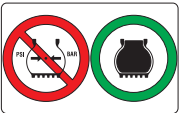
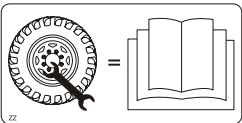

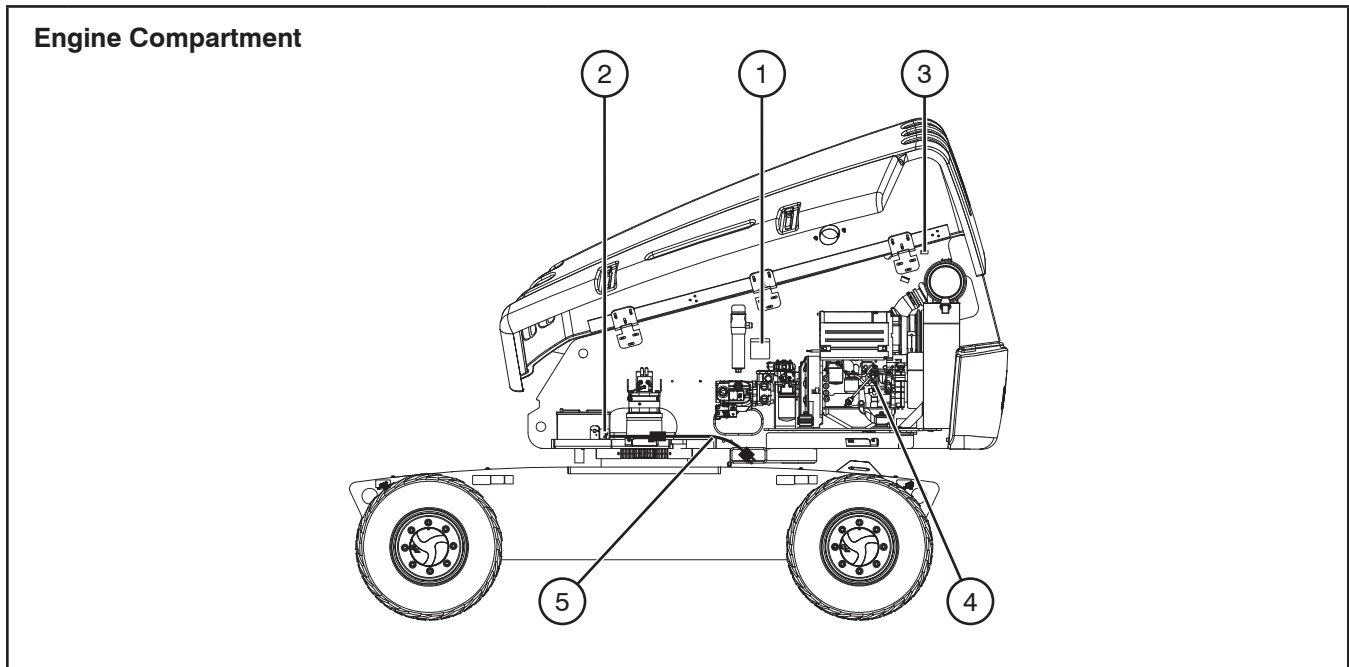

No.	Label Pictorial	Description
9		<p><b>Tire Sealant (If Equipped)</b> Indicates that tire sealant is present inside the tires.</p>
10		<p><b>Tire Pressure</b> Indicates rated tire pressure.</p>
		<p><b>Foam-filled Tire (If Equipped)</b> Indicates foam-filled tire.</p>
11		<p><b>Wheel Specifications</b> Refer to manual for wheel type, offset, pressure and torque.</p>

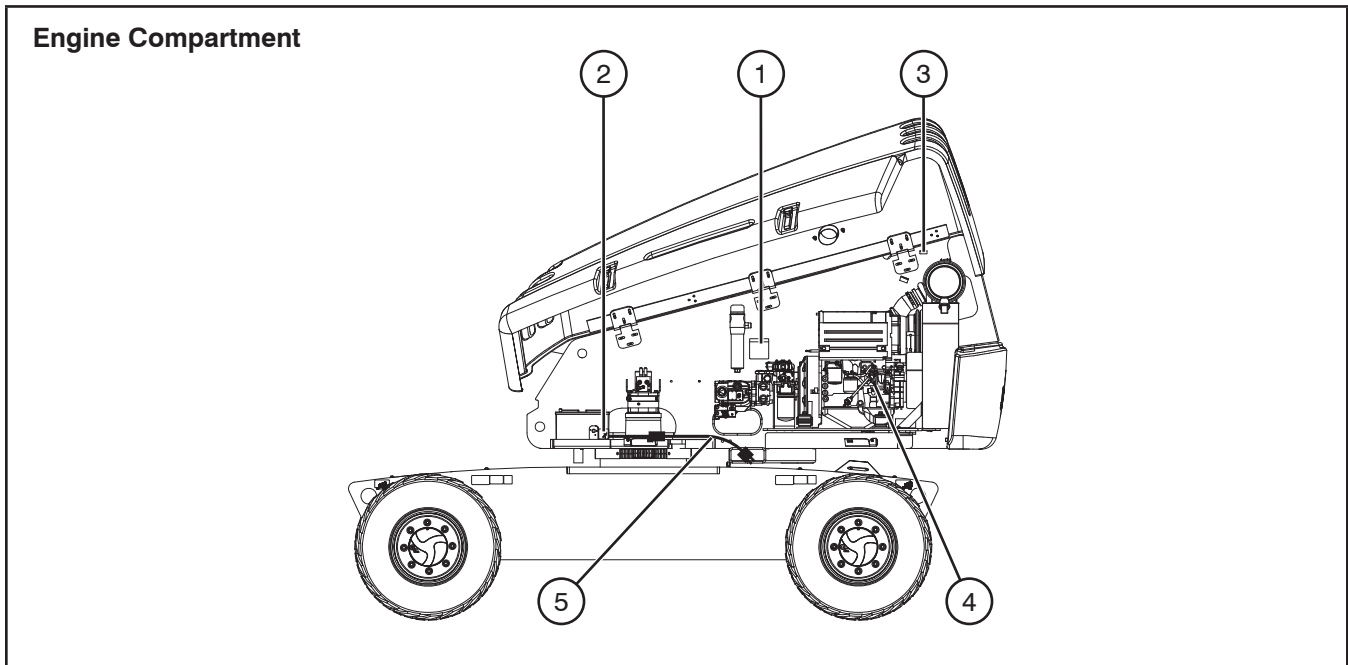

No.	Label Pictorial	Description
1		<p><b>Winching/Towing/Pushing Procedure</b> Refer to Operating manual.</p> <ol style="list-style-type: none"> <li>Block or chock wheels to prevent aerial platform from rolling.</li> <li>Turn main power disconnect switch to off position. At engine side:</li> <li>Locate bypass valve (marked with yellow colour) on inboard side of drive pump.</li> <li>Rotate bypass valve flat using pliers or 1/4" (7mm) wrench by 90 degrees (clockwise). At hydraulic tank side:</li> <li>Locate brake valve and pump.</li> <li>Push in black knob.</li> <li>Pump by slowly pushing red knob in and out until 300 psi/ 21 bar shows on the gauge (if equipped). Brake is now released. Refer to <a href="#">Section 2.5 Winching &amp; Towing Procedure</a>.</li> <li>A) Remove blocks from wheels. B) Push/tow/winch to desired location.</li> <li>Block or chock wheels to prevent aerial platform from rolling. At hydraulic tank side:</li> <li>Reset brake by pulling out black knob. At engine side:</li> <li>Close bypass valve by rotating 90 degrees (counterclockwise) to normal condition (flat is parallel to shaft axis).</li> </ol> <p style="text-align: center;"><b>NOTE</b></p> <p style="text-align: center;">Before operation, ensure all blocks are removed from wheels.</p>





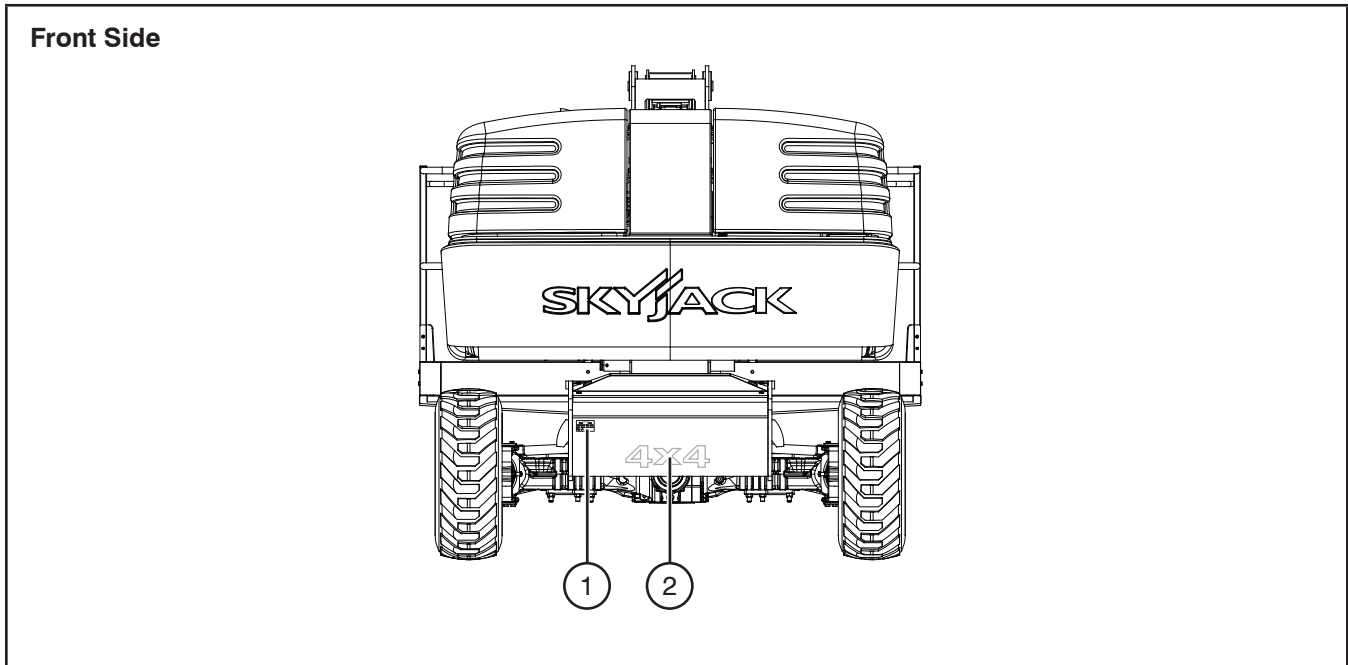

No.	Label Pictorial	Description
2		<p><b>Main Power Disconnect</b></p> <p>Main power disconnect lever</p>
3		<p><b>Warning - Do Not Alter</b></p> <p>Do not alter or disable limit switches or other safety devices.</p>
4		<p><b>Cold Weather Factory Oil (If Equipped)</b></p> <p>Recommended factory oil (5W-30) for cold weather start option</p>
5		<p><b>Battery Warmer/Hydraulic Oil Heater (If Equipped)</b></p> <p>Battery warmer/hydraulic oil heater cord</p>

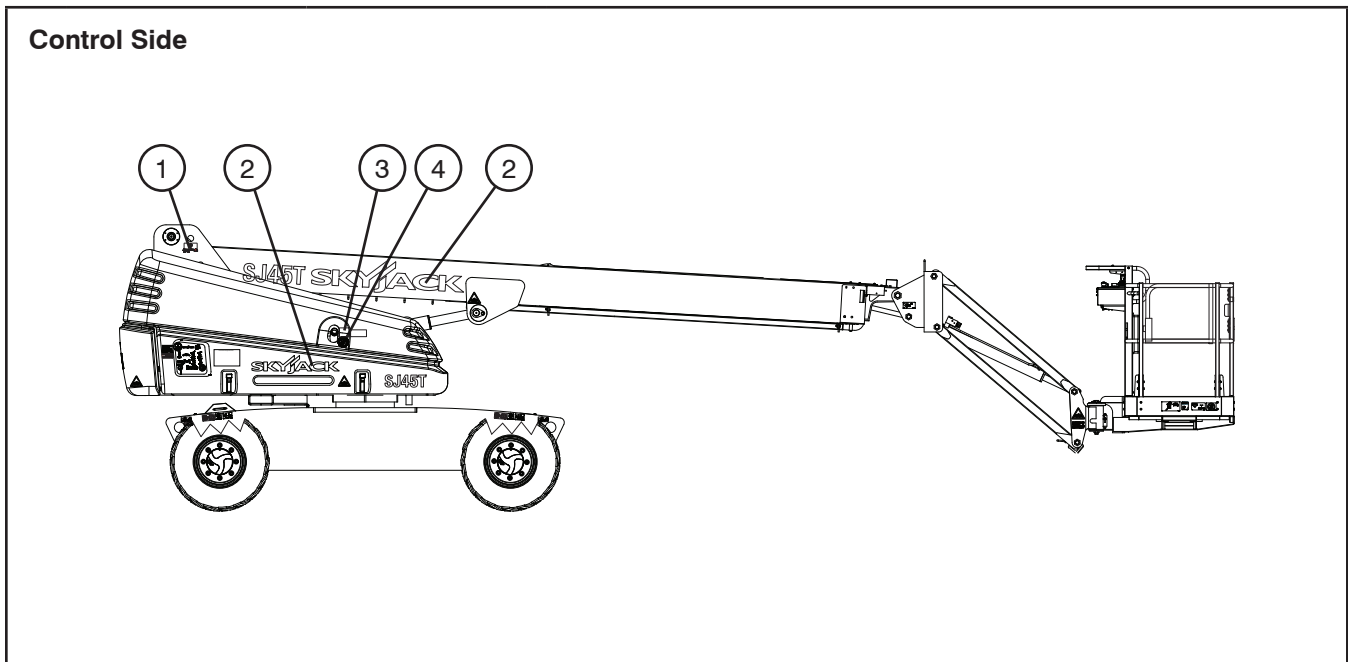

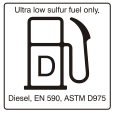
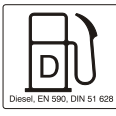

No.	Label Pictorial	Description
1		<p><b>Serial Plate*</b></p> <p>Product identification and specifications                      *Serial plate will vary, may not be as shown.</p>
2		<p><b>4x4 (If Equipped)</b></p> <p>Product Identifier - 4 wheel drive</p>

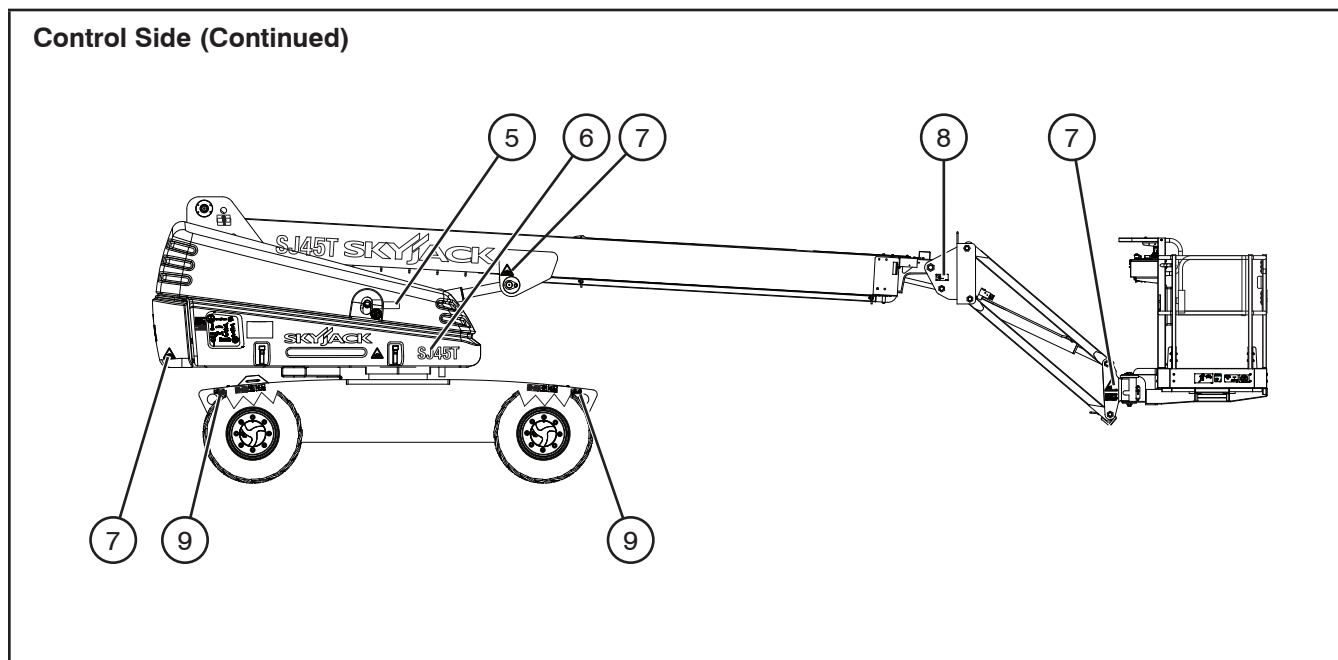

No.	Label Pictorial	Description
1		<p><b>Lift Points</b> Only use these points for lifting.</p>
2		<p><b>Skyjack Logo</b> Skyjack</p>
3		<p><b>Diesel Ultra Low Sulfur Only</b> Diesel Ultra Low Sulfur Only</p>
		<p><b>Diesel</b> Use diesel fuel only.</p>
		<p><b>Unleaded Fuel</b> Use unleaded gasoline only.</p>
4		<p><b>No Smoking</b> Do not smoke near this location.</p>

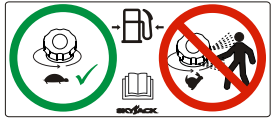

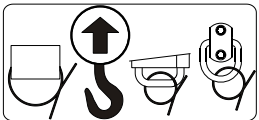
No.	Label Pictorial	Description
5		<p><b>Open Fuel Cap Slowly</b> Refer to Operating manual.</p> <p>Open fuel cap slowly to prevent fuel from spraying out of fuel tank.</p>
6	<p>SJ45T</p>	<p><b>Model Number*</b></p> <p>Product Identifier *Model number will vary, may not be as shown.</p>
7		<p><b>Body Crushing Hazard</b></p> <p>Danger - Body crushing hazard</p>
8		<p><b>Crushing Hazard</b></p> <p>Danger - Crushing hazard</p>
9		<p><b>Lift and Tie Down Points</b></p> <p>Only use these points for lifting or tying down.</p>

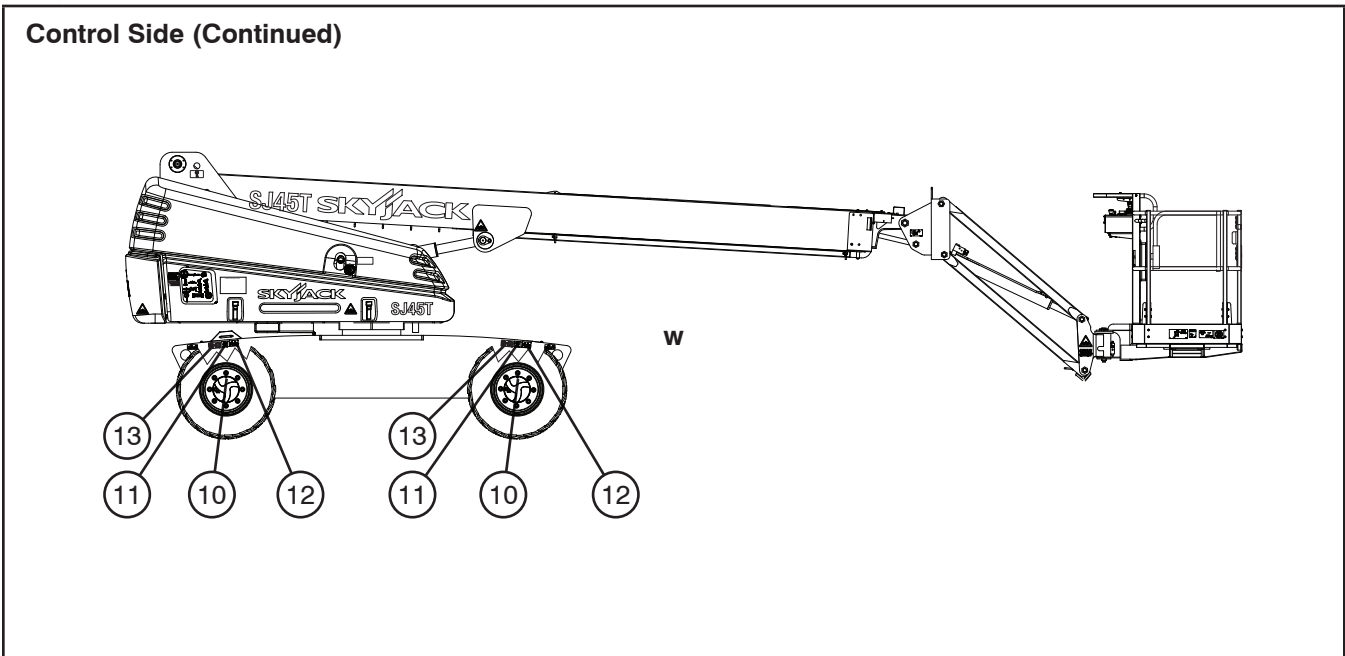



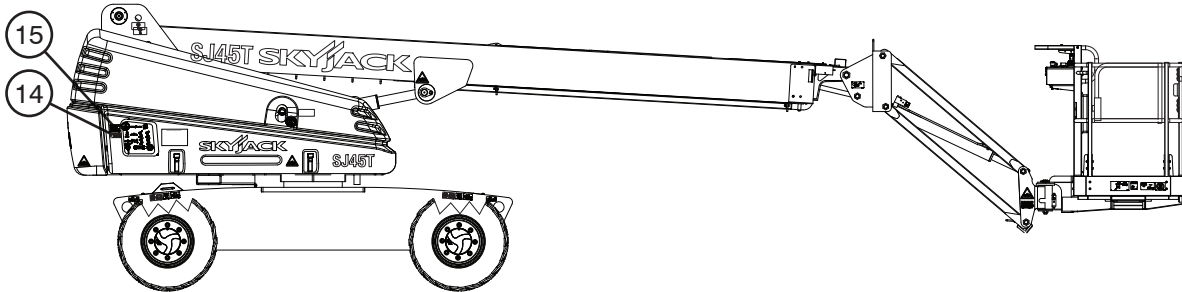

No.	Label Pictorial	Description
10		<p><b>Tire Sealant (If Equipped)</b> Indicates that tire sealant is present inside the tires.</p>
11		<p><b>Wheel Load*</b> Indicates rated wheel load. *Wheel load will vary over different aerial platforms.</p>
12		<p><b>Tire Pressure</b> Indicates rated tire pressure.</p>
		<p><b>Foam-filled Tire (If Equipped)</b> Indicates foam-filled tire.</p>
13		<p><b>Wheel Specifications</b> Refer to manual for wheel type, offset, pressure and torque.</p>

Control Side (Continued)

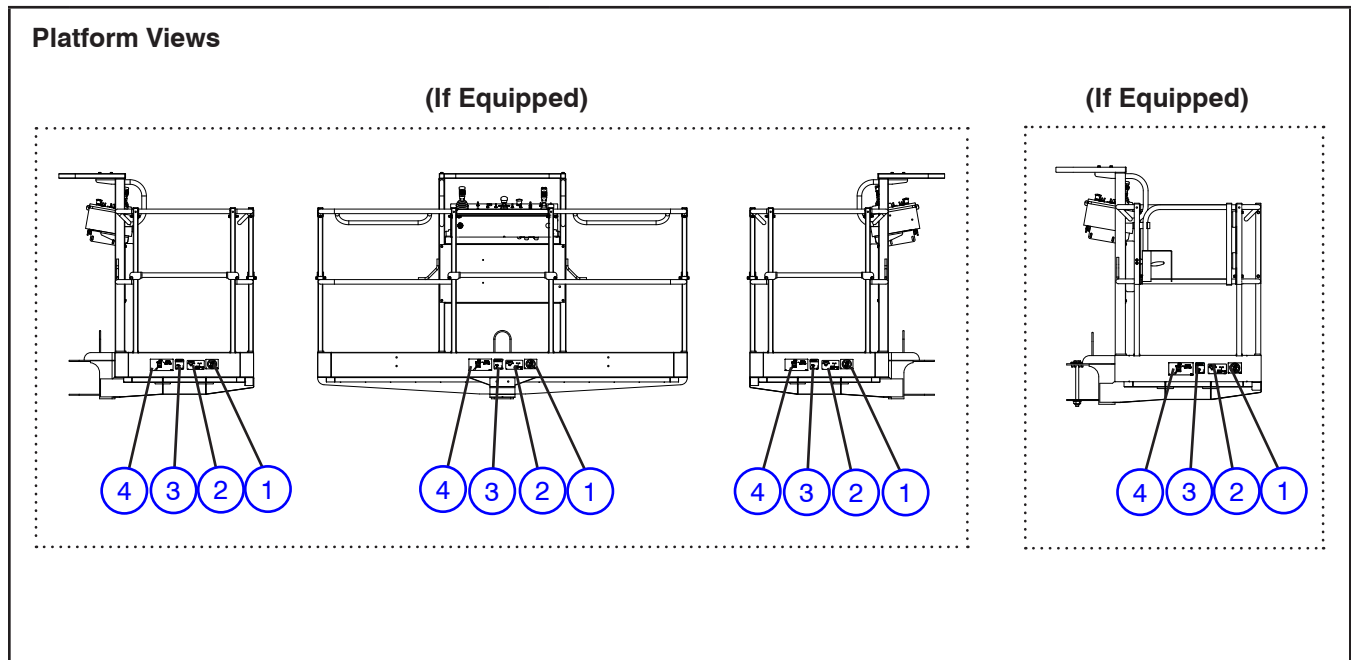

No.	Label Pictorial	Description
14	<p>The label pictorial for item 14 features an orange header with a warning triangle. Below it is a table with columns for 'Model' and 'S/N', each followed by a series of blank lines for handwritten entry. To the left of the table is a key icon and the Skyjack logo.</p>	<p><b>Annual Inspection</b></p> <p>Ensure that work platform has received annual inspection prior to operation.</p>
15	<p>The label pictorial for item 15 has a green background with white text. It is titled 'EMERGENCY LOWERING PROCEDURE' and lists three steps for the base controls.</p>	<p><b>Emergency Lowering Procedure</b></p> <p>In case of emergency, follow procedure outlined in label to lower the platform.</p>

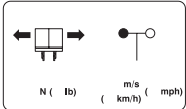

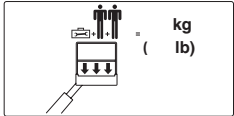
No.	Label Pictorial	Description
1		<p><b>No Jewelry</b></p> <p>Caution - Do not wear jewelry.</p>
2	 <p>N ( lb)      m/s ( km/h) ( mph)</p>	<p><b>Horizontal Load Rating</b></p> <p>Apply no more than the indicated side load. Operate below indicated wind speed only.</p>
3		<p><b>Operator's Daily Inspection</b></p> <p>Refer to the Operating manual. Perform visual inspection and function tests at the beginning of each shift. Refer to <a href="#">Table 4.7 Maintenance and Inspection Schedule</a>.</p>
4	 <p>kg ( lb)</p>	<p><b>Platform Capacity</b></p> <p>Rated work load in each configuration. Rated work load includes the weight of both personnel and material, and maximum number of people in each configuration. Do not exceed total weight or maximum number of people. Load platform uniformly. *Platform capacity will vary over different aerial platforms.</p>

Control Compartment

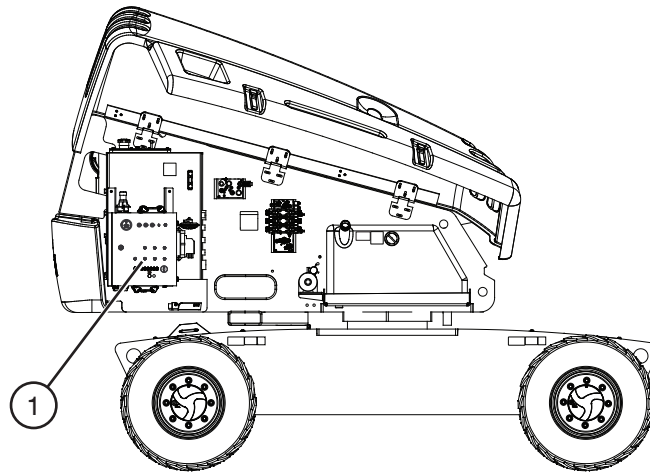

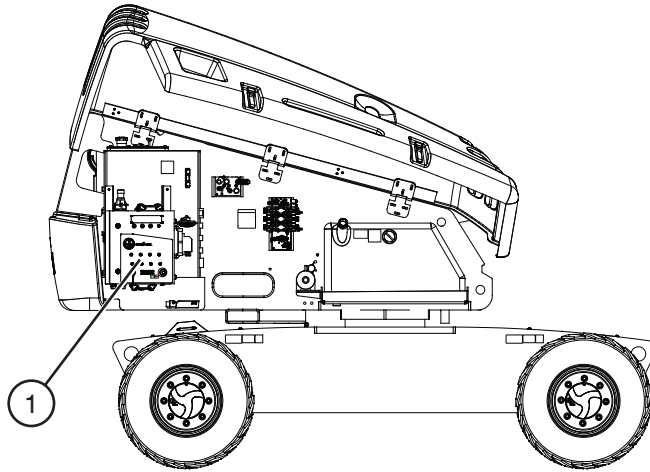

No.	Label Pictorial	Description
1a		<p><b>Base Control Console</b></p> <p>Push “” breaker back in to reset. Select and hold “” to enable error blink code for engine control unit (ECU). Read “” operating manual.</p> <p>Push and hold “” to start engine, “” to enable the emergency power unit or “” to enable base control functions.</p> <p>Select “” to rotate platform to the left or “” to rotate to the right.</p> <p>Select “” to tilt platform up or “” to tilt platform down.</p> <p>Select “” to move jib up or “” to move jib down.</p> <p>Select “” to rotate turret to the left or “” to rotate to the right.</p> <p>Select “” to raise main boom or “” to lower main boom.</p> <p>Select “” to extend fly boom or “” to retract fly boom.</p> <p>Select “” to turn engine off, “” to enable base control console or “” to enable platform control console.</p> <p>Push “” emergency stop to stop engine and disable controls.</p>

Control Compartment

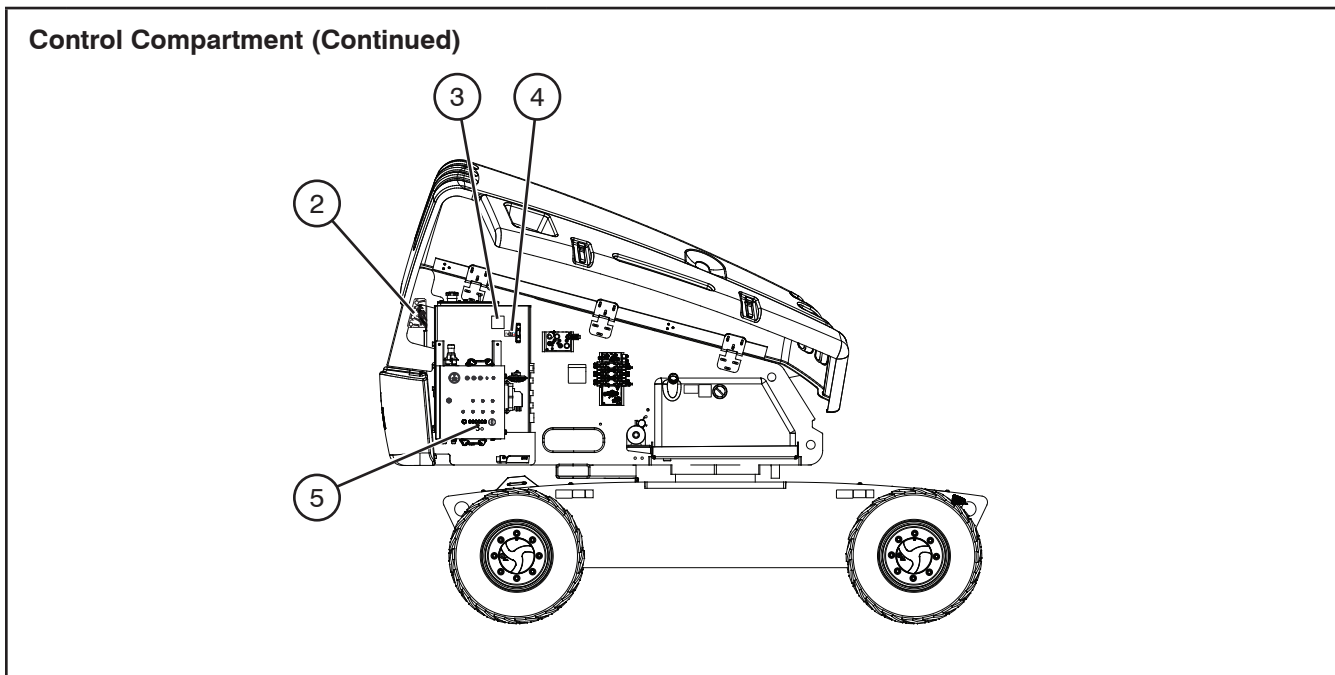

No.	Label Pictorial	Description
1b		<p><b>Base Control Console</b></p> <p>Push “” breaker back in to reset. Select and hold “” to enable error blink code for engine control unit (ECU).          Read “” operating manual.</p> <p>Push and hold “” to start engine or “” to enable the emergency power unit.</p> <p>Select “” to rotate platform to the left or “” to rotate to the right.</p> <p>Select “” to tilt platform up or “” to tilt platform down.</p> <p>Select “” to move jib up or “” to move jib down.</p> <p>Push and hold “” in either direction to enable base control functions.</p> <p>Select “” to rotate turret to the left or “” to rotate to the right.</p> <p>Select “” to raise main boom or “” to lower main boom.</p> <p>Select “” to extend fly boom or “” to retract fly boom.</p> <p>Select “” to enable base control console, “” to turn engine off or “” to enable platform control console.</p> <p>Push “” emergency stop to stop engine and disable controls.</p>



No.	Label Pictorial	Description
2		<p><b>Grease Points Maintenance</b></p> <p>Refer to service and maintenance manual “” for lubricating aerial platform.</p>
3		<p><b>Hydraulic Oil</b></p> <p>Replace hydraulic fluid with Shell Tellus T46 or approved alternate (see <a href="#">Table 4.2b</a>).</p> <p>(Note: Cold weather starting temperatures can be improved with Skyjack options. Please consult your nearest Skyjack service center.)</p>
4		<p><b>Hydraulic Oil Level</b></p> <p>Indicates minimum/maximum oil level.</p>
5		<p><b>Positive Air Shutoff (If Equipped)</b></p> <p>Use this switch to trigger the positive air shutoff valve.</p>

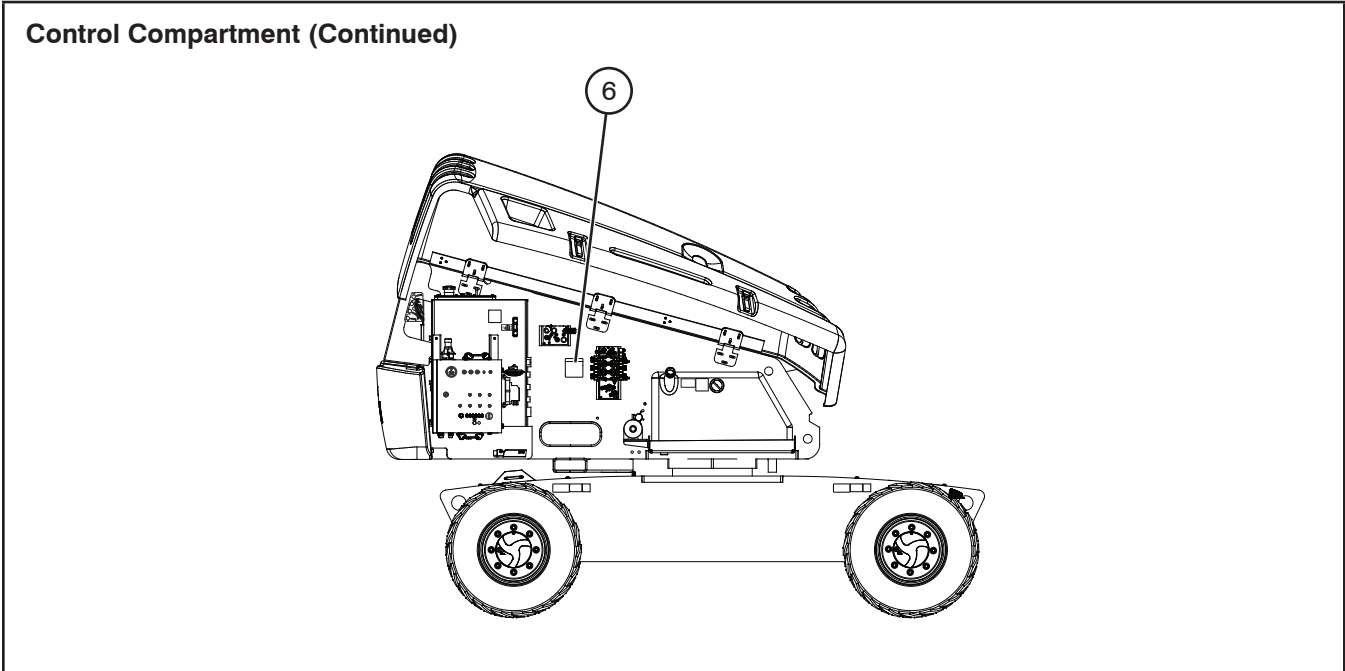

No.	Label Pictorial	Description
6		<p><b>Winching/Towing/Pushing Procedure</b> Refer to Operating manual.</p> <ol style="list-style-type: none"> <li>1. Block or chock wheels to prevent aerial platform from rolling.</li> <li>2. Turn main power disconnect switch to off position. At engine side:</li> <li>3. Locate bypass valve (marked with yellow colour) on inboard side of drive pump.</li> <li>4. Rotate bypass valve flat using pliers or 1/4" (7mm) wrench by 90 degrees (clockwise). At hydraulic tank side:</li> <li>5. Locate brake valve and pump.</li> <li>6. Push in black knob.</li> <li>7. Pump by slowly pushing red knob in and out until 300 psi/ 21 bar shows on the gauge (if equipped). Brake is now released. Refer to <a href="#">Section 2.5 Winching &amp; Towing Procedure</a>.</li> <li>8. A) Remove blocks from wheels. B) Push/tow/winch to desired location.</li> <li>9. Block or chock wheels to prevent aerial platform from rolling. At hydraulic tank side:</li> <li>10. Reset brake by pulling out black knob. At engine side:</li> <li>11. Close bypass valve by rotating 90 degrees. (counterclockwise) to normal condition (flat is parallel to shaft axis).</li> </ol> <p style="text-align: center;"><b>NOTE</b></p> <p style="text-align: center;">Before operation, ensure all blocks are removed from wheels.</p>

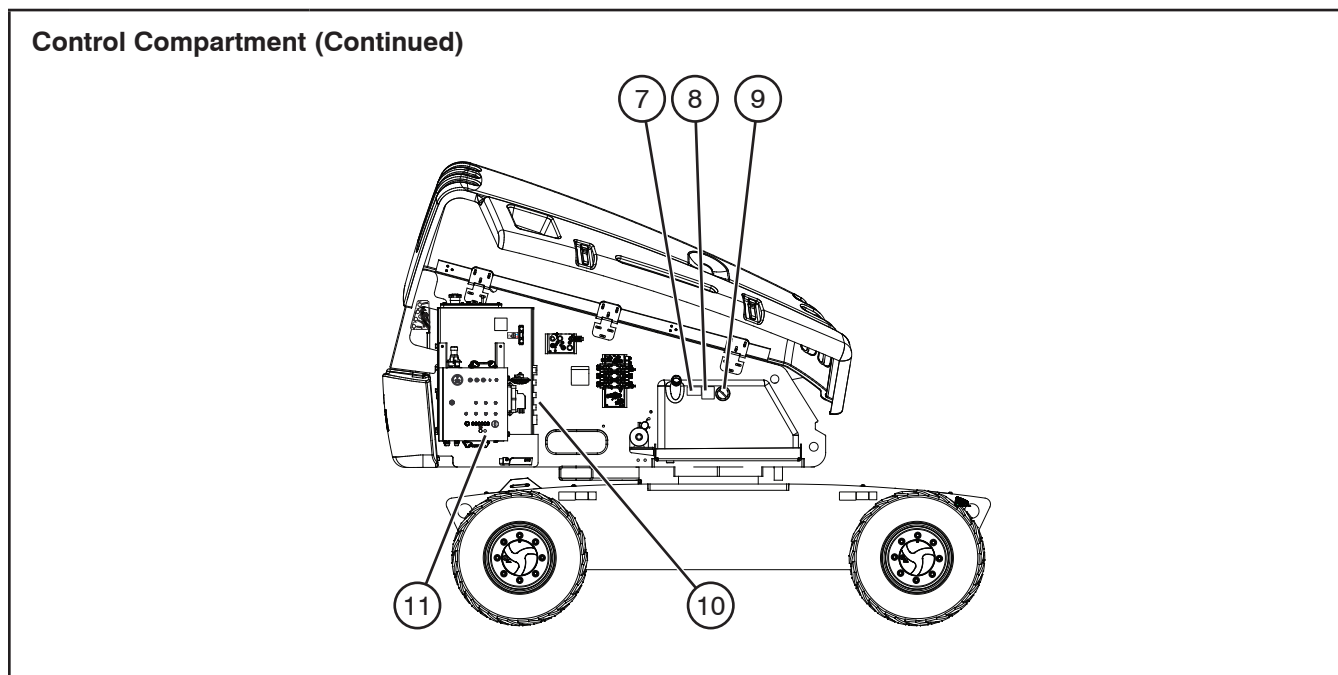

No.	Label Pictorial	Description
7		<p><b>Open Fuel Cap Slowly</b> Refer to Operating manual.</p> <p>Open fuel cap slowly to prevent fuel from spraying out of fuel tank.</p>
8		<p><b>Diesel Ultra Low Sulfur Only</b> Diesel Ultra Low Sulfur Only</p>
		<p><b>Diesel</b> Use diesel fuel only.</p>
		<p><b>Unleaded Fuel</b> Use unleaded gasoline only.</p>
9		<p><b>No Smoking</b> Do not smoke near this location.</p>
10		<p><b>Connect AC Supply</b> Connect AC supply here.</p>
11		<p><b>Glow Plug Procedure</b></p> <p>When “” glow plug (diesel) light is on, “” wait and do not “” start engine.</p>

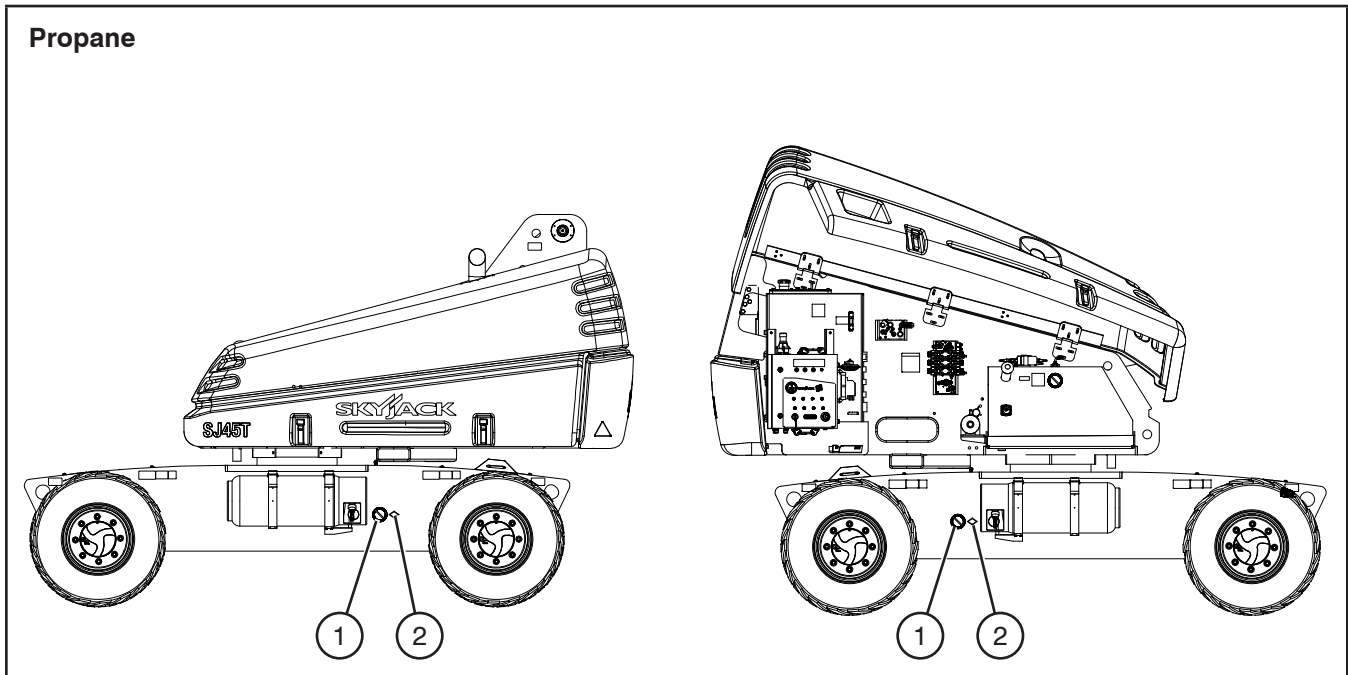

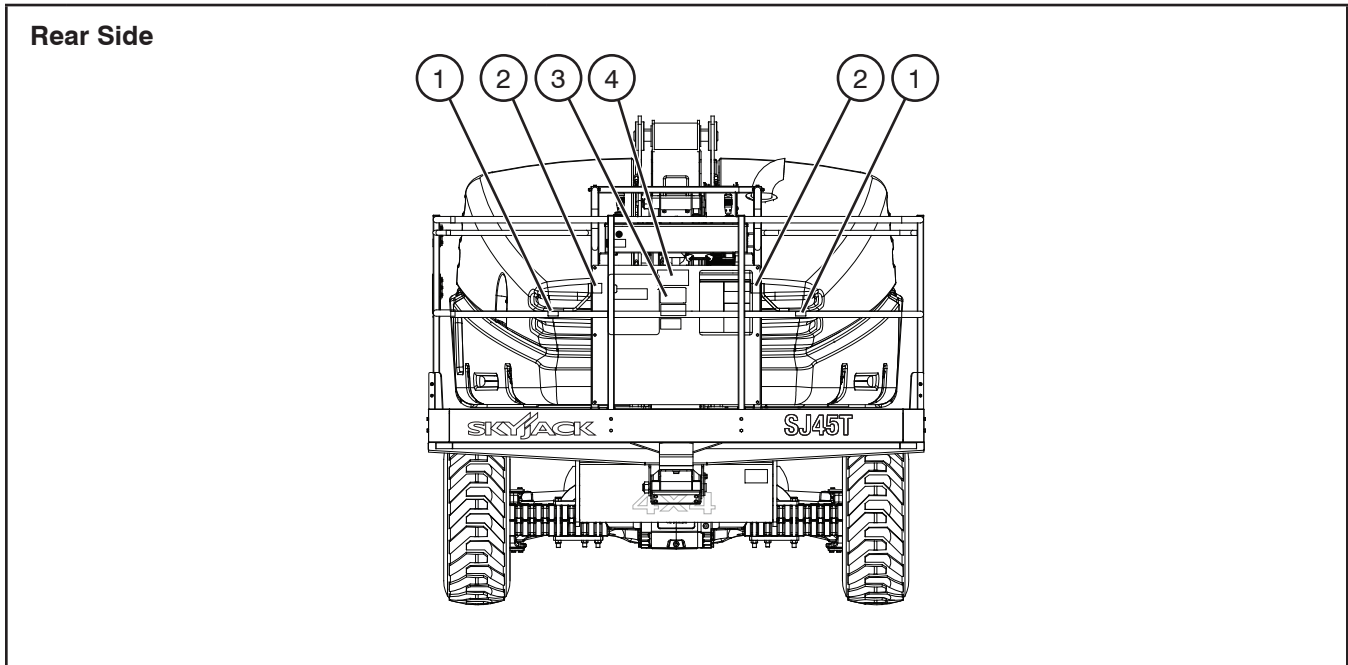

No.	Label Pictorial	Description
1		<p><b>No Smoking</b> Do not smoke near this location.</p>
2		<p><b>Propane</b> Indicates propane storage location.</p>



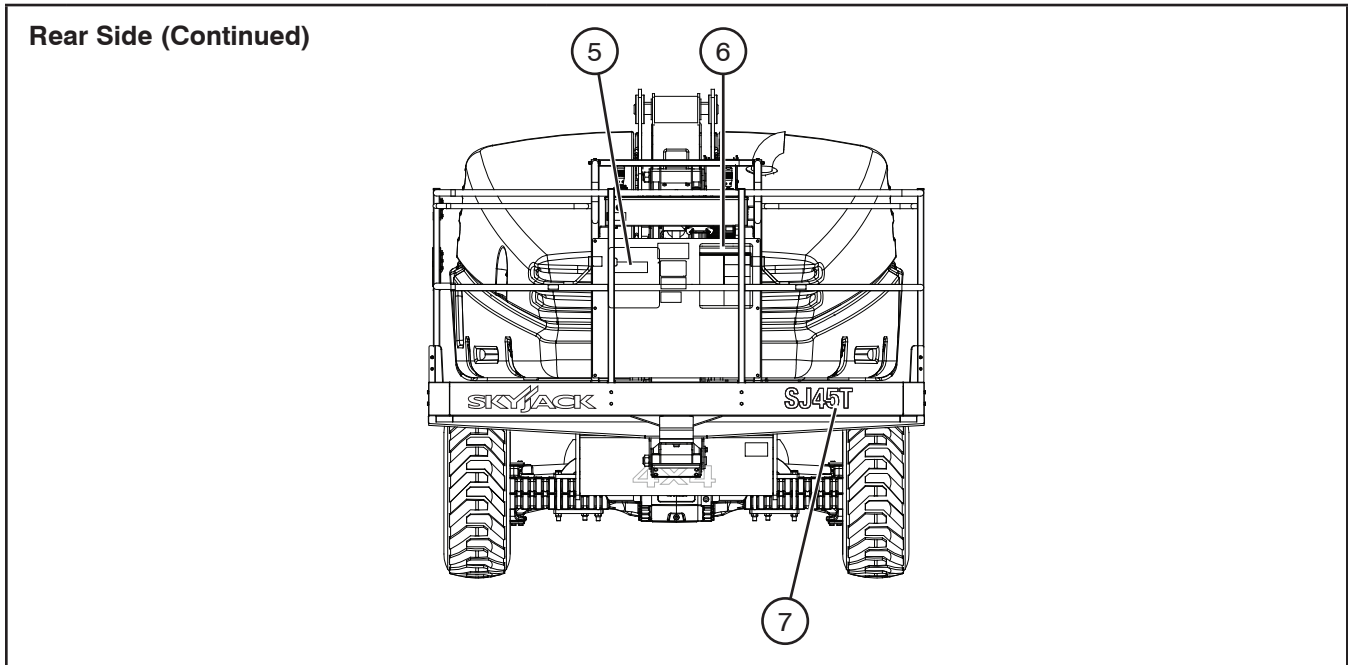



No.	Label Pictorial	Description
1		<p><b>Warning - No Step</b></p> <p>No step warning</p>
2		<p><b>Fall Protection Anchorage</b></p> <p>Anchor safety belt/harness tethers here. Rated for one (1) person per anchorage.</p>
3		<p><b>Horizontal Load Rating</b></p> <p>Apply no more than indicated side load. Operate below indicated wind speed only.</p>
4		<p><b>Platform Capacity*</b></p> <p>Rated work load in each configuration. Rated work load includes the weight of both personnel and material, and maximum number of people in each configuration. Do not exceed total weight or maximum number of people. Load platform uniformly. *Platform capacity will vary over different aerial platforms.</p>

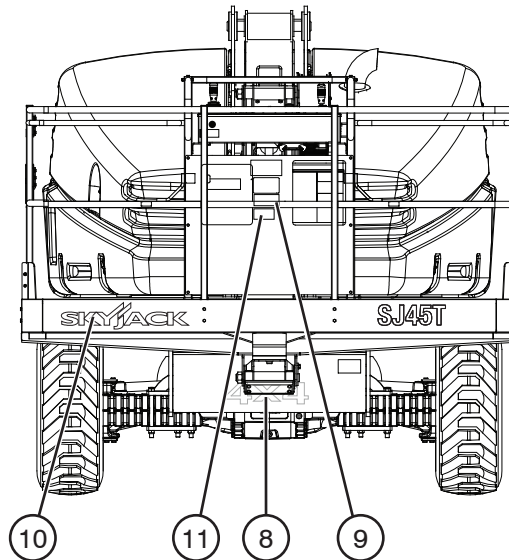

No.	Label Pictorial	Description
5		<p><b>Manual Box</b></p> <p>Indicates location of operating manual.</p>
6		<p><b>Hazard Identification</b></p> <p>Refer to <a href="#">Section 1: Safety Rules</a>. Read and understand outlined risks associated with this work platform prior to operation.</p>
7		<p><b>Model Number*</b></p> <p>Product Identifier *Model number will vary, may not be as shown.</p>

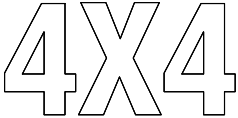
Rear Side (Continued)





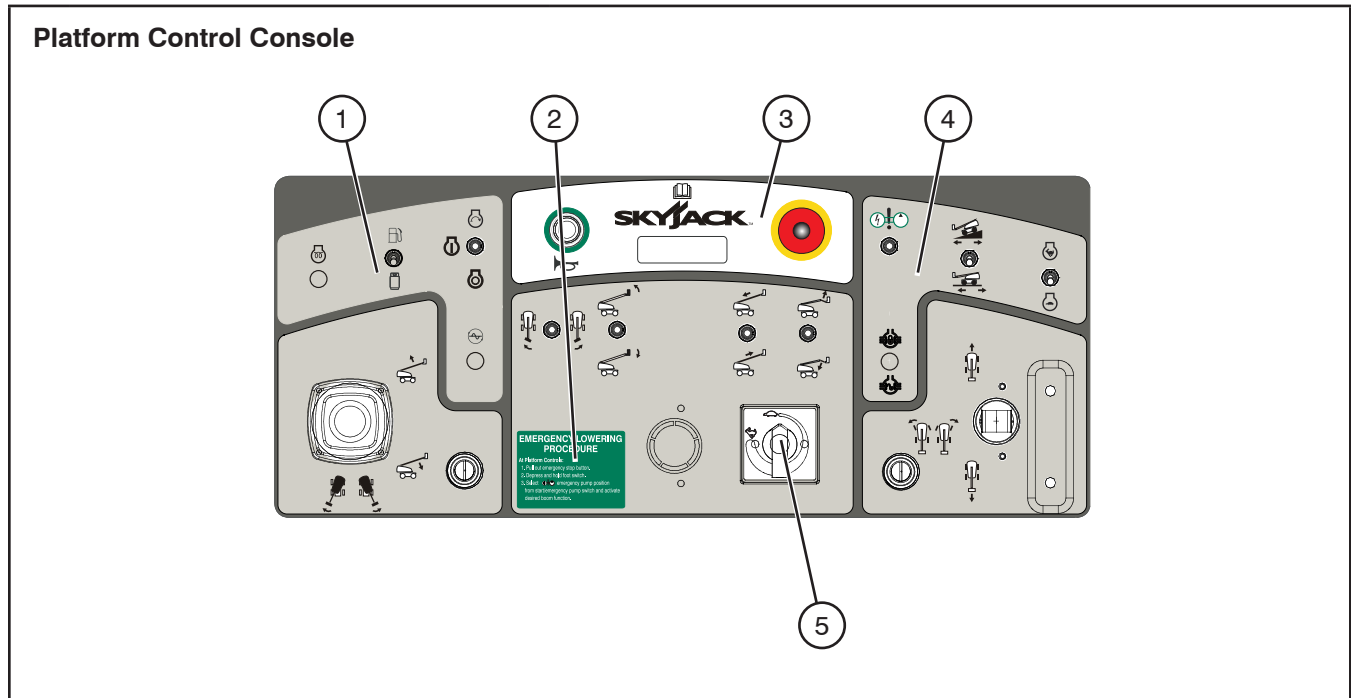



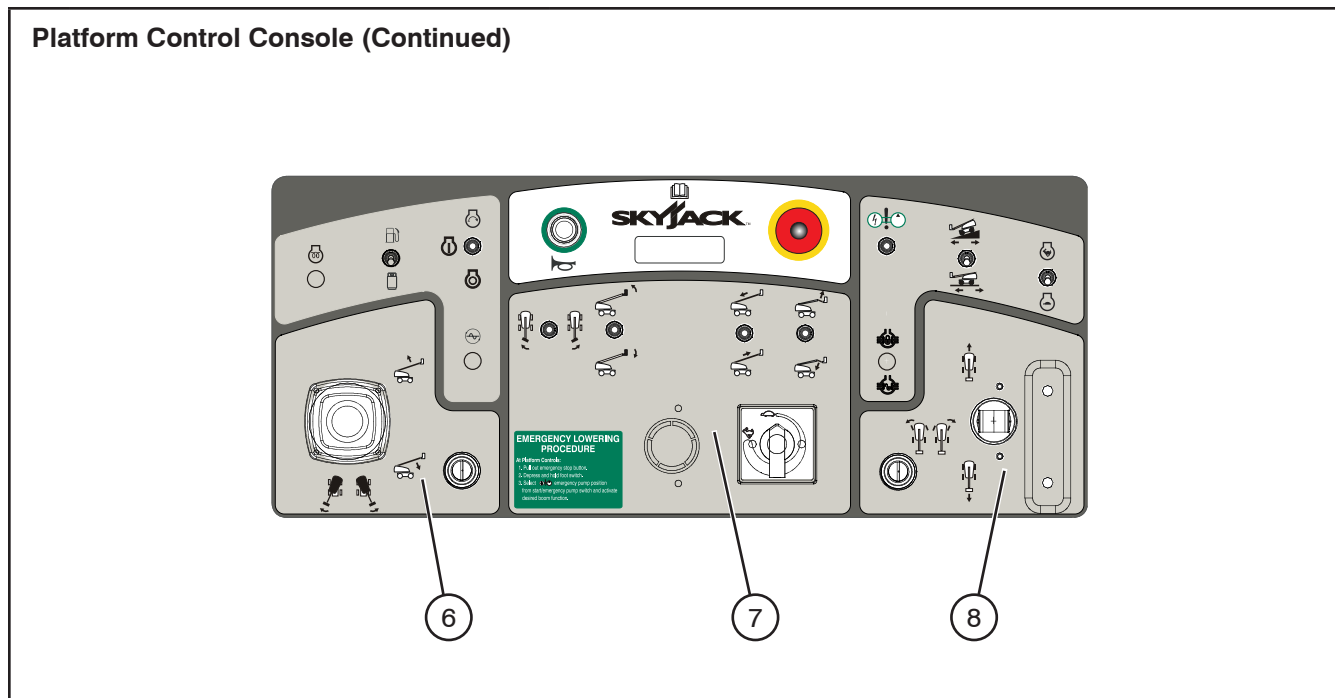

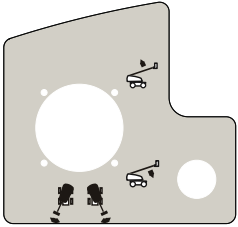



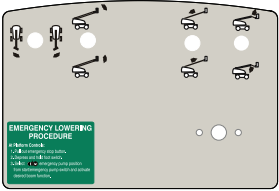



No.	Label Pictorial	Description
8		<p><b>4x4 (If Equipped)</b></p> <p>Product Identifier - 4 wheel drive</p>
9		<p><b>AWPT "Click It!"</b></p> <p>Indicates full body harness awareness.</p>
10		<p><b>Skyjack Logo</b></p> <p>Skyjack</p>
11		<p><b>Warning - California Proposition 65</b></p> <p>Cancer and Reproductive Harm-  <a href="https://www.p65warnings.ca.gov/">https://www.p65warnings.ca.gov/</a>.</p>



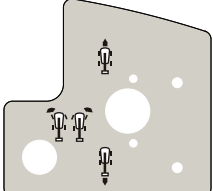



No.	Label Pictorial	Description
1		<p><b>Glow Plugs/Start Engine</b></p> <p>Select “” to energize glow plugs.                      Select “” for diesel fuel or “” for propane fuel.                      Push and hold “” to start engine and then return to “” on position or select “” to turn engine off.                      Select “” to turn hydraulic generator on or “” to turn it off.</p>
2		<p><b>Emergency Lowering Procedure</b></p> <p>Follow procedure outlined in label to lower the platform.</p>
3		<p><b>E-Stop/Horn</b></p> <p>Select “” to sound horn.                      Read operating manual “”.                      Push “” emergency stop to stop engine and disable controls.</p>
4		<p><b>Engine Controls/Emergency Power Unit</b></p> <p>Select “” to enable emergency power unit.                      Select “” low torque (higher speed) or “” high torque (lower speed). Select “” high torque when driving on a slope.                      Select either “” high or “” low engine throttle speed.                      Select “” to engage differential lock or “” to disengage differential lock.</p>

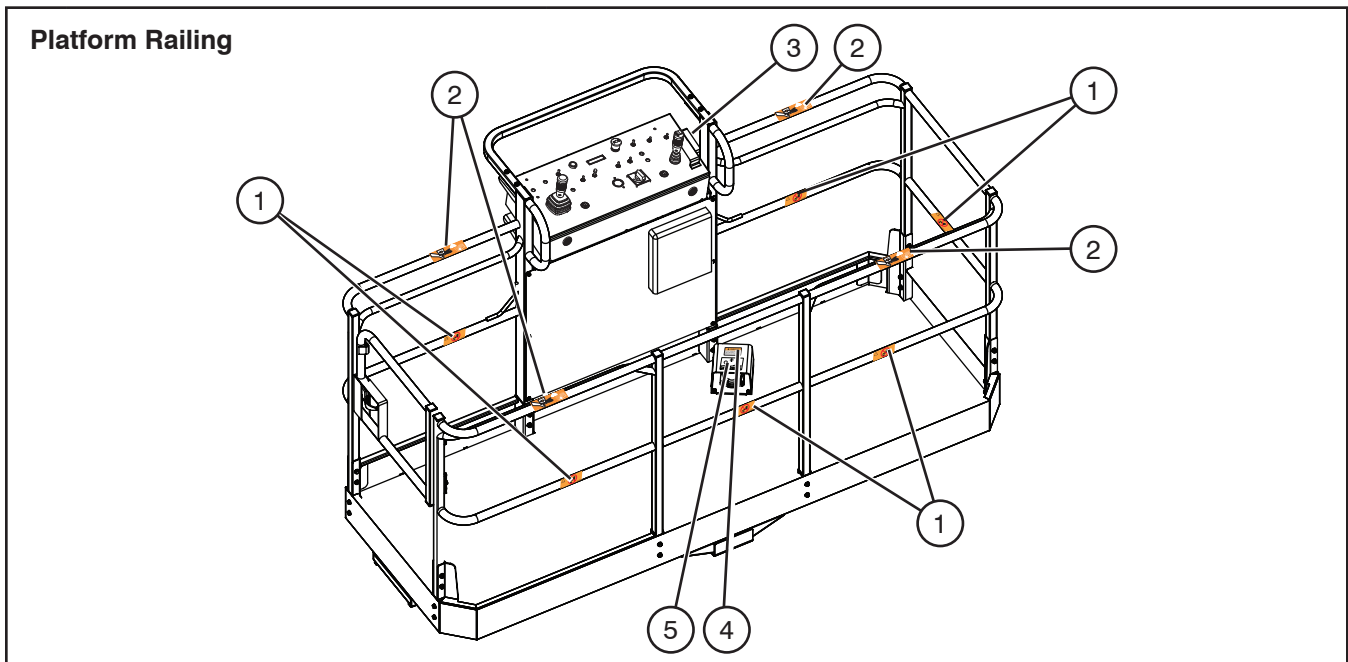

No.	Label Pictorial	Description
5		<p><b>Boom Speed Adjuster Dial</b></p> <p>Adjust dial to vary speed of fly boom extension/retraction, jib raising/lowering and platform rotation movements.</p>
6		<p><b>Boom/Turret Controller</b></p> <p>Push and hold controller in this direction “” to rotate turret to the left or “” to rotate turret to the right.</p> <p>Push and hold the controller in this direction “” to raise main boom or “” to lower main boom.</p>
7		<p><b>Boom/Jib/Platform Controls</b></p> <p>Select “” to rotate platform to the left or “” to the right.</p> <p>Select “” to tilt platform up or “” to tilt platform down.</p> <p>Select “” to extend fly boom or “” to retract fly boom.</p> <p>Select “” to move jib up or “” to move jib down.</p>
8		<p><b>Drive/Steer Controller</b></p> <p>Push and hold controller in this direction “” to drive forward or “” to drive backward.</p> <p>Push and hold controller in this direction “” to steer left or “” to steer right.</p>

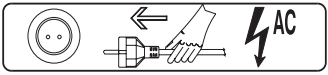

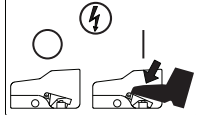
No.	Label Pictorial	Description
1		<p><b>Warning - No Step</b> No step warning</p>
2		<p><b>Crushing Hazard</b> Danger - Crushing hazard</p>
3		<p><b>Connect AC Supply</b> Connect AC supply here.</p>
4		<p><b>Warning - Do Not Alter</b> Do not alter or disable limit switches or other safety devices.</p>
5		<p><b>Footswitch Enable (On/Off)</b> Depress and hold footswitch to enable platform function.</p>

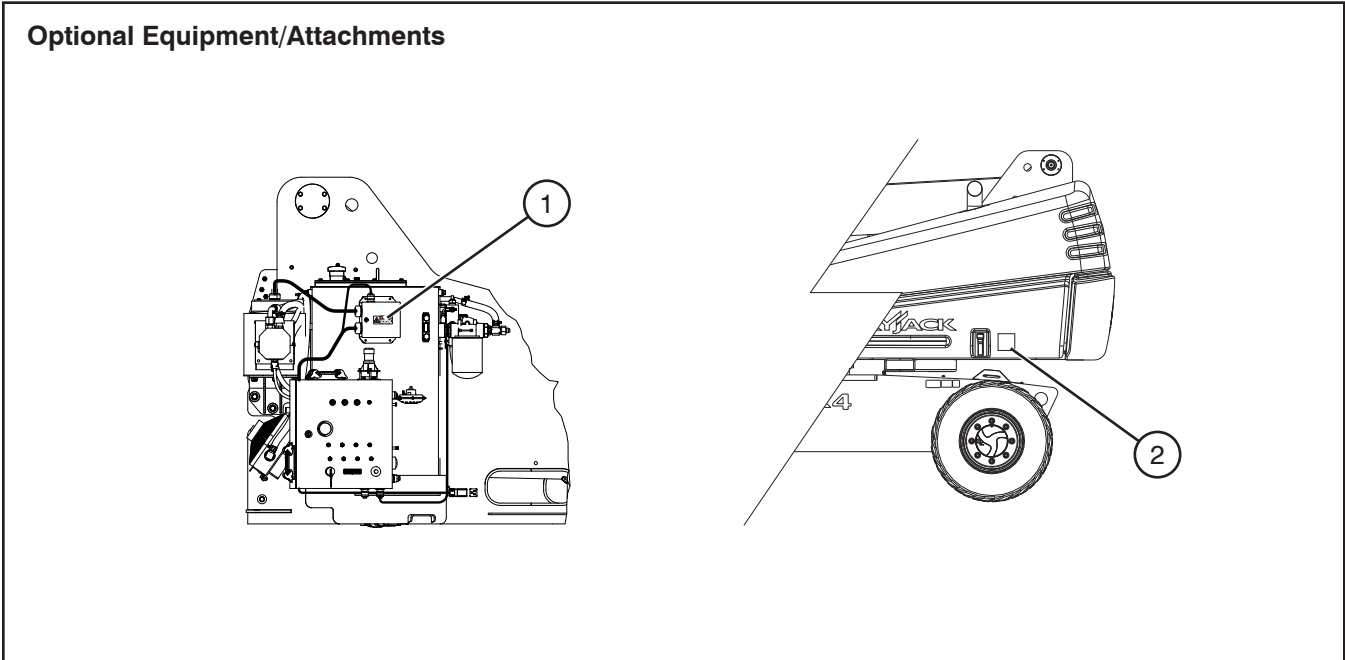

No.	Label Pictorial	Description
1		<p><b>Warning - Hazardous Voltage</b></p> <p>Electric shock warning.</p>
2		<p><b>Catalytic Muffler Lower Emissions</b></p> <p>Indicates lower emissions.</p>

Optional Equipment/Attachments (Continued)

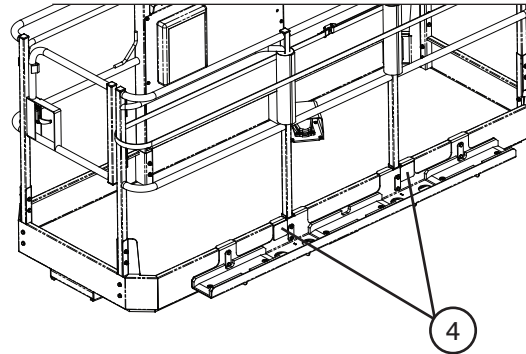
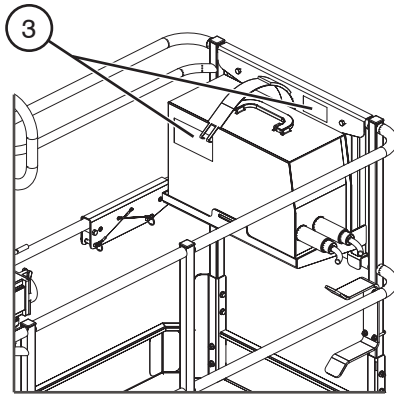

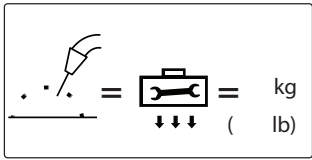
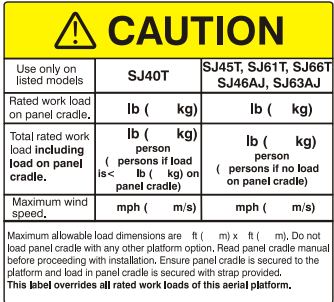
No.	Label Pictorial	Description
3		<p><b>Welder Weight</b></p> <p>Indicates rated weight of welder.</p>
4		<p><b>Glazier Tray Capacity</b></p> <p>Indicates rated capacity of glazier tray.</p>

## 6.0 Skyjack Features

Your Skyjack machine may be equipped with the following features:

### **SKYCODED™**

At the heart of every Skyjack machine, proven and simplistic control systems using Skyjack's colour coded and numbered wiring system make our machines the easiest to trouble shoot and repair. – Black #14 is for the lift function on a 3219, and it is lift on a 63AJ. Using an analog based control system allows Skyjack AWP's to operate using a simplified system with fewer and less expensive components – less maintenance and lower costs.

### **AXLDRIVE™**

Skyjack's mechanical "axle based" drive system gives positive traction and excellent rough ground "terrainability". This industry leading terrain capability means one can use the Skyjack Rough Terrain Scissor Lifts, Boom Lifts and Telehandlers in the most challenging of conditions.

### **EASYDRIVE™**

A unique boom feature only utilized by Skyjack- the Boom Lift drive function operates in accordance with the general orientation of the turret's counterweight over the chassis (i.e. joystick forward=counterweight facing forward). This provides intuitive operation by allowing the unit to move in the general direction of the joystick's movement.

### **ACCESSORYZERS™**

Having equipment with features and functionality that allow you and your customers to do more is a vital part of the utilization equation. Skyjack offers a range of accessory products to further expand a given products adaptability and your power to offer a truly flexible rental choice.





# WARNING

Cancer and Reproductive Harm-

<https://www.p65warnings.ca.gov/>.

**SKYJACK**<sup>™</sup>

[www.skyjack.com](http://www.skyjack.com)