



OPERATING MANUAL (ANSI/CSA)

VERTICAL MAST

MODELS **SJ12** **SJ16**

171728AFA
April 2019

SKYJACK[™]

This manual is based on Serial Number(s):

SJ12 & SJ16 14 005 746 & Above

Please refer to the website (www.skyjack.com) for older Serial Numbers.

Skyjack Service Center

3451 Swenson Ave. St. Charles,
Illinois, 60174 USA
Phone: 630-262-0005
Toll Free: 1-800-275-9522
Fax: 630-262-0006
Email: service@skyjack.com

Parts (North America)

Toll Free: 1-800-965-4626
Toll Free Fax: 1-888-782-4825
E-mail: parts@skyjack.com

Skyjack Australia Pty Ltd.

Unit 1, 35 Honeycomb Drive
Eastern Creek
New South Wales 2766
Australia
Tel: +61 (0) 2 9854 0700
Fax: +61 (0) 2 9854 0777

Parts & Service (Europe)

Unit 1 Maes Y Clawdd
Maesbury Road Industrial Estate
Oswestry, Shropshire SY10 8NN UK
Phone: +44-1691-676-235
Fax: +44-1691-676-238
E-mail: info@skyjackeurope.co.uk

Skyjack Brasil

Alameda Júpiter, 710
Loteamento American Park Empresarial
Indaiatuba, SP, Brasil 13347-653
Tel: +55 19 3936 0132

The Safety Alert Symbol identifies important safety messages on aerial platform, safety signs in manuals or elsewhere. When you see this symbol, be alert to the possibility of personal injury or death. Follow the instructions in the safety message.



This Safety Alert Symbol means attention!

Become alert! Your safety is involved.



DANGER

DANGER indicates an imminently hazardous situation which, if not avoided, will result in death or serious injury.



WARNING

WARNING indicates a potentially hazardous situation which, if not avoided, could result in death or serious injury.



CAUTION

CAUTION indicates a potentially hazardous situation which, if not avoided, may result in minor or moderate injury. It may also be used to alert against unsafe practices.

IMPORTANT

IMPORTANT indicates a procedure essential for safe operation and which, if not followed, may result in a malfunction or damage to the aerial platform.

Table of Contents

Section 1 - About Your Aerial Platform	5
<i>Read and Heed</i>	5
<i>Safety Rules</i>	6
Section 2 - Familiarization	13
2.1 <i>Familiarization of SJ12/16 Series</i>	13
2.2 <i>Component Identification</i>	14
2.3 <i>Visual & Daily Maintenance Inspections</i>	17
2.4 <i>Function Tests</i>	22
2.5 <i>Winching and Towing Procedures</i>	29
2.6 <i>Emergency Lowering Procedure</i>	30
Section 3 - Operation	31
3.1 <i>General</i>	31
3.2 <i>Major Components</i>	32
3.3 <i>Major Assemblies</i>	33
3.4 <i>Serial Number Nameplate</i>	33
3.5 <i>Component Identification</i>	34
3.6 <i>Component Identification (Optional Equipment/Attachments)</i>	36
3.7 <i>Operator's Responsibility</i>	37
3.8 <i>Start Operation</i>	38
3.9 <i>Loading/Unloading</i>	41
3.10 <i>Platform Traversing</i>	43
3.11 <i>Accessing the Hydraulic/Electrical Compartment</i>	43
3.12a <i>Battery Maintenance</i>	44
3.12b <i>Battery Maintenance (If Equipped)</i>	46
Section 4 - Tables	49
<i>Table 4.1 Standard and Optional Features</i>	49
<i>Table 4.2 Owner's Annual Inspection Record</i>	50
<i>Table 4.3 Specifications and Features</i>	51
<i>Table 4.4 Maximum Platform Capacities (Evenly Distributed)</i>	52
<i>Table 4.5 Floor Loading Pressure</i>	52
<i>Table 4.6 Maintenance and Inspection Schedule</i>	54
<i>Table 4.7 Operator's Checklist</i>	55
Section 5 - Labels	57

SKYJACK is continuously improving and expanding product features on its equipment, therefore, specifications and dimensions are subject to change without notice.

Aerial Platform and Mobile Elevating Work Platform Definition

A mobile device that has a positionable platform supported from ground level by a structure.

Purpose of Equipment

The SKYJACK Vertical Mast series aerial platforms are designed to transport and raise personnel, tools and materials to overhead work areas.

Use of Equipment

The aerial platform is a highly maneuverable, mobile work station. Work platform elevation and elevated driving must only be done on a firm, level surface.

Manual

The operating manual is considered a fundamental part of the aerial platform. It is a very important way to communicate necessary safety information to users and operators. A complete and legible copy of this manual must be kept in the provided weather-resistant storage compartment on the aerial platform at all times.

Operator

The operator must read and completely understand both this operating manual and the safety panel label located on the platform and all other warnings in this manual and on the aerial platform. Compare the labels on the aerial platform with the labels found within this manual. If any labels are damaged or missing, replace them immediately.

Service Policy and Warranty

SKYJACK warrants each new Vertical Mast series aerial platform to be free of defective parts and workmanship for the first 24 months. Any defective part will be replaced or repaired by your local SKYJACK dealer at no charge for parts or labor. Contact the SKYJACK Service Department for warranty statement extensions or exclusions.

Optional Accessories

The SKYJACK aerial platform is designed to accept a variety of optional accessories.

Scope of this Manual

- a. This manual applies to the ANSI/SIA, CSA version of the SJ12 and SJ16 Vertical Mast Series aerial platform models listed on [Table 4.1](#).
 - **Equipment identified** with “ANSI” meets the ANSI SIA-A92.6-2006 standard.
 - **Equipment identified** with “CSA” meets the CSA B354.2-01 standard.
- b. **CSA (Canada)**

Operators are required to conform to national, territorial/provincial and local health and safety regulations applicable to the operation of this aerial platform.
- c. **ANSI/SIA (United States)**

Operators are required by the current ANSI/SIA A92.6 standards to read and understand their responsibilities in the manual of responsibilities before they use or operate this aerial platform.

**WARNING**

Failure to comply with your required responsibilities in the use and operation of the aerial platform could result in death or serious injury!

Operator Safety Reminders

A study conducted by St. Paul Travelers showed that most accidents are caused by the failure of the operator to follow simple and fundamental safety rules and precautions.

You, as a careful operator, are the best insurance against an accident. Therefore, proper usage of this aerial platform is mandatory. The following pages of this manual should be read and understood completely before operating the aerial platform.

Common sense dictates the use of protective clothing when working on or near machinery. Use appropriate safety devices to protect your eyes, ears, hands, feet and body.

Any modifications from the original design are strictly forbidden without written permission from SKYJACK.

Electrocution Hazard

This aerial platform is not electrically insulated. Maintain a Minimum Safe Approach Distance (MSAD) from energized power lines and parts as listed below. The operator must allow for the platform to sway, rock or sag. This aerial platform does not provide protection from contact with or proximity to an electrically charged conductor.

Per ANSI A92.6-2006 8.10(7)

“The operator shall perform only that work for which he or she is qualified, in compliance with all applicable safety related work practices intended to prevent electric shock covered by the Code of Federal Regulations (CFR) 1910.333. The operator’s level of competence shall be established only by persons qualified to do so. Operators shall maintain the appropriate minimum approach distance (MAD) from energized power lines and parts covered by CFR 1910.333 (c).”

Unqualified persons must maintain a minimum approach distance of 10 feet from any energized power line up to 50 kV. Energized power lines over 50 kV require a greater minimum approach distance to be maintained. Refer to CFR 1910.333.

As per CSA B354.2-01

“The operator shall maintain the minimum safe approach distance (MSAD) from energized conductors at all times in accordance with the authority having jurisdiction.”

**DO NOT USE THE AERIAL PLATFORM AS A GROUND FOR WELDING.
DO NOT OPERATE THE AERIAL PLATFORM DURING LIGHTNING OR STORMS.
DO NOT OPERATE THE AERIAL PLATFORM NEAR POWER LINES. MAINTAIN A MINIMUM SAFE APPROACH DISTANCE (MSAD) FROM ENERGIZED POWER LINES.**

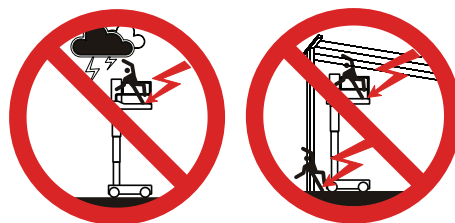

 DANGER Avoid Power Lines	
Minimum Safe Approach Distance	
ANSI/SIA A92.6-2006 & CSA B354.2-01 Requirements	
Voltage Range (Phase to Phase)	Minimum Safe Approach Distance (Feet)
0 to 300V	Avoid Contact
Over 300V to 50KV	10
Over 50KV to 200KV	15
Over 200KV to 350KV	20
Over 350KV to 500KV	25
Over 500KV to 750KV	35
Over 750KV to 1000KV	45
FAILURE TO AVOID THIS HAZARD WILL RESULT IN DEATH OR SERIOUS INJURY!	

60023AD-ANSI

Safety Precautions

Know and understand the safety precautions before going on to next section.



WARNING

Failure to heed the following safety precautions could result in tip over, falling, crushing, or other hazards leading to death or serious injury.

- **KNOW** all national, state or territorial/provincial and local rules which apply to your aerial platform and job site.
- **TURN** main power disconnect switch “○” off when leaving the aerial platform unattended. Remove the key to prevent unauthorized use of the aerial platform.
- **WEAR** all the protective clothing and personal safety devices issued to you or called for by job conditions.

- **DO NOT** wear loose clothing, dangling neckties, scarves, rings, wristwatches or other jewelry while operating this lift.



- **AVOID** entanglement with ropes, cords or hoses.



- **AVOID** falling. Stay within the boundaries of the guardrails.



- **DO NOT** raise the aerial platform in windy or gusty conditions.



- **DO NOT** increase the lateral surface area of the platform. Increasing the area exposed to the wind will decrease aerial platform stability. Avoid tenting.



- **DO NOT** drive elevated near depressions or holes of any type, loading docks, debris, drop-offs or surfaces that may affect the stability of the aerial platform.



- **IF OPERATION IN AREAS WITH HOLES OR DROP-OFFS IS ABSOLUTELY NECESSARY**, elevated driving shall not be allowed. Position the aerial platform horizontally only with the platform fully-lowered. After ensuring that all 4 wheels or outriggers (if equipped) have contact with a firm, level surface, the aerial platform can be elevated. After elevation, the drive function must not be activated.



- **DO NOT** elevate or drive elevated on a slope. Elevated driving must be done on a firm, level surface.



- **DO NOT** ascend or descend a grade when elevated. When fully lowered, ascending or descending grades up to maximum rated inclines listed in [Table 4.3](#).



Safety Precautions (Continued)

Know and understand the safety precautions before going on to next section.

- **DO NOT** operate on surfaces not capable of holding the weight of the aerial platform including the rated load, e.g., covers, drains, and trenches.



- **DO NOT** drive elevated on a soft or uneven surface.

- **DO NOT** operate an aerial platform that has ladders, scaffolding or other devices mounted on it to increase its size or work height. It is prohibited.

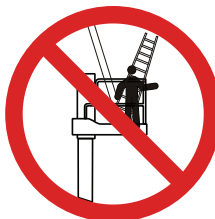

- **DO NOT** exert side forces on aerial platform while elevated.



- **DO NOT** use the aerial platform as a crane. It is prohibited.



- **DO NOT** sit, stand or climb on the guardrails. It is prohibited.



- **DO NOT** climb on base and mast. It is prohibited.



- **AVOID** overhead obstructions. Be aware of overhead obstructions or other possible hazards around aerial platform when lifting or driving.



- **DO NOT** raise the aerial platform while the aerial platform is on a truck, fork lift or other device or vehicle.

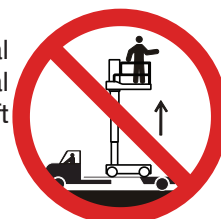

- **AVOID** crushing hazards. Be aware of crushing hazards when lifting or driving. Keep all body parts inside the aerial platform.



- **DO NOT** lower the platform unless the area below is clear of personnel and obstructions.



- **ENSURE** that there are no personnel or obstructions in the path of travel, including blind spots.



- **DO NOT** use with improperly inflated/damaged tires or wheels. Refer to [Section 2: Wheel/Tire Assembly](#).



Safety Precautions (Continued)

Know and understand the safety precautions before going on to next section.

- **DO NOT** alter or disable limit switches or other safety devices.

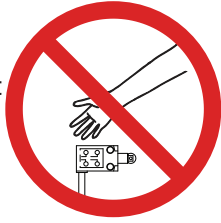

- **DO NOT** use under influence of alcohol or drugs.



- **DO NOT** use the aerial platform without guardrails, locking pins and the entry gate (if equipped) in place.

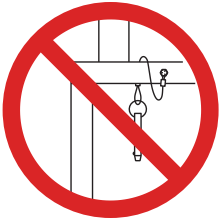

- **DO NOT** access the hydraulic/ electrical compartment while the platform is raised.



- **DO NOT** exceed the rated capacity of the aerial platform.



- **BE AWARE** of blind spots when operating the aerial platform.

- **STUNT** driving and horseplay are prohibited.

- **DO NOT** attempt to free a snagged platform with lower controls until personnel are removed from the platform.

- **DO NOT** distribute load unevenly.



- **DO NOT** position the aerial platform against another object to steady the platform.

- **DO NOT** place materials on the guardrails or materials that exceed the confines of the guardrails unless approved by Skyjack.

- **DO NOT** operate if aerial platform is not working properly or if any parts are damaged or worn.



- **DO NOT** leave aerial platform unattended with key in key switch.



Safety Precautions (Continued)

Know and understand the safety precautions before going on to next section.

Fall Protection

As per the ANSI A92.6-2006 standard, “The guardrail system of the aerial platform provides fall protection. If occupant(s) of the platform are required to wear personal fall protection equipment (PFPE), occupants shall comply with instructions provided by the aerial platform manufacturer (remanufacturer) regarding anchorage(s).”

If additional fall protection is required, by an employer or the authority having jurisdiction, Skyjack recommends the use of a fall restraint system to keep an occupant within the confines of the platform, and thus not expose the occupant to any fall hazard requiring a fall arrest.

All personal fall protection equipment must comply with applicable governmental regulations and must be inspected and used in accordance with the manufacturer’s recommendations.

All personal fall protection equipment must be attached only to approved anchorage points within the platform of the aerial platform.



WARNING

Entering and exiting the aerial platform should only be done using the three points of contact.

- **Use only equipped access openings.**
 - **Enter and exit only when the aerial platform is in the fully retracted position.**
- Do use three points of contact to enter and exit the platform. Enter and exit the platform from the ground only. Face the aerial platform when entering or exiting the platform.

- Three points of contact means that two hands and one foot or one hand and two feet are in contact with the aerial platform or the ground at all times during entering and exiting.



WARNING

An operator should not use any aerial platform that:

- **does not appear to be working properly.**
- **has been damaged or appears to have worn or missing parts.**
- **has alterations or modifications not approved by the manufacturer.**
- **has safety devices which have been altered or disabled.**
- **has been tagged or locked out for non-use or repair.**

Failure to avoid these hazards could result in death or serious injury.

Job site Inspection

- Do not use in hazardous locations.
- Perform a thorough job site inspection prior to operating the aerial platform, to identify potential hazards in your work area.
- Be aware of moving equipment in the area. Take appropriate actions to avoid collision.

2.1 Familiarization of SJ12/16 Series



WARNING

Aerial Platform Familiarization should be given only to individuals who are QUALIFIED And TRAINED to operate an aerial platform.

Do not operate this aerial platform without proper authorization and training. Failure to avoid this hazard could result in death or serious injury.

It is the responsibility of the operator to read, completely understand and follow all instructions and warnings contained in this operating manual and on the aerial platform.

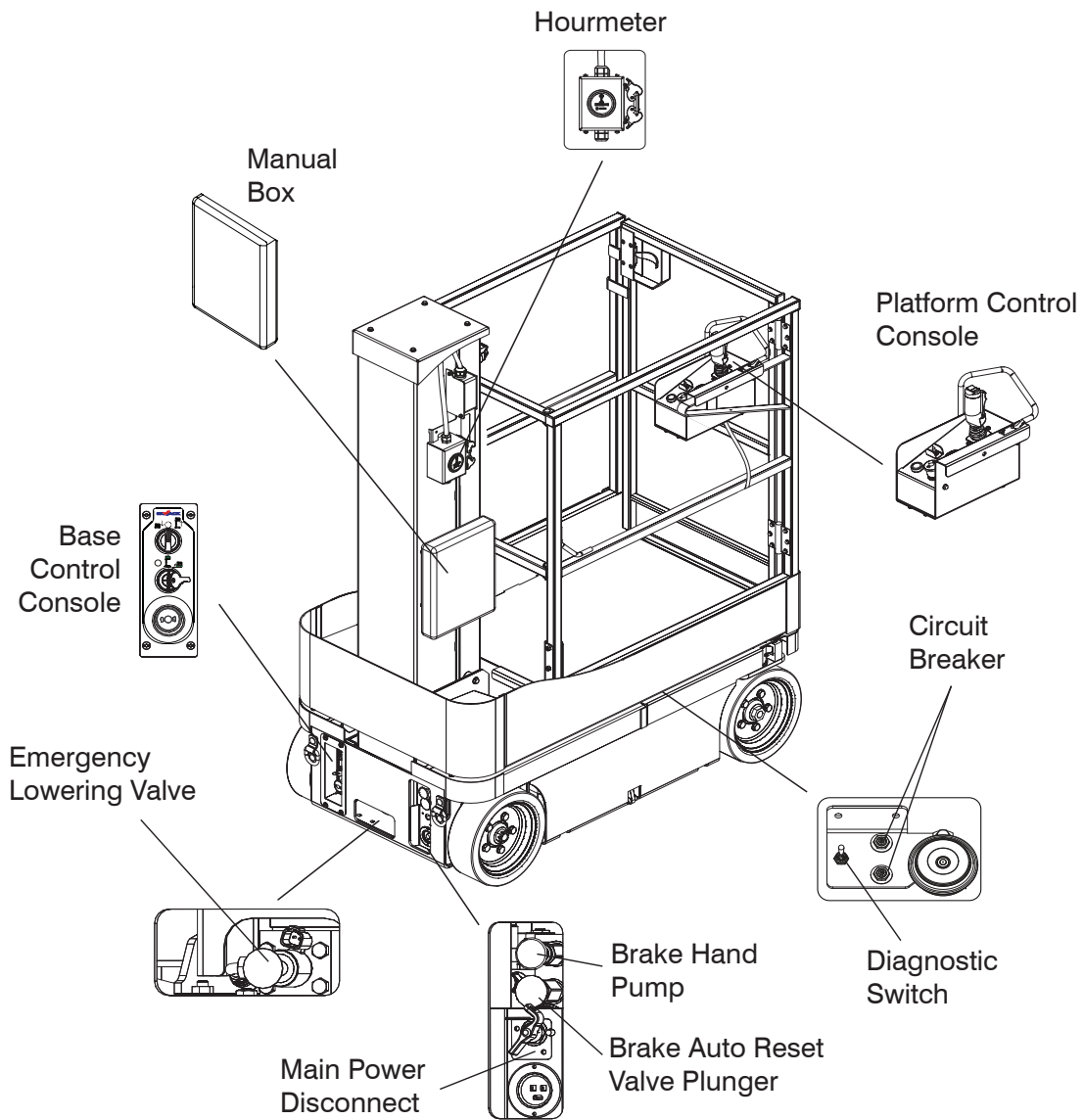

FAMILIARIZATION

2.2 Component Identification

The following descriptions are for identification, explanation and locating purposes only.

2.2-1 Main Power Disconnect Switch

This switch is located at the rear of the base.

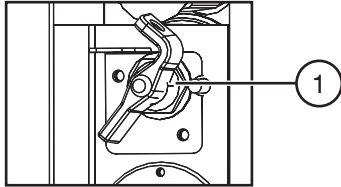

Figure 2-1. Main Power Disconnect Switch

1. **Main Power Disconnect Switch** - This switch, when in “○” off position, disconnects power to all circuits. Switch must be in “|” on position to operate any circuit. Turn switch “○” off when transporting aerial platform.

2.2-2 Brake System

The brake system is located at the rear of the base. The brakes must be manually disengaged before pushing, winching or towing. Refer to [Section 2.5-1](#) for procedure on how to release brakes manually. The system contains the following controls:

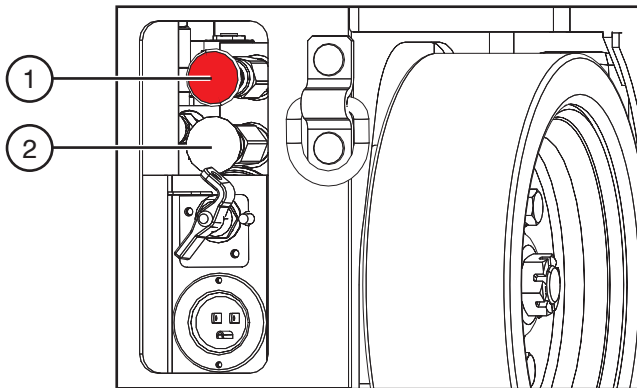

Figure 2-2. Disc Brake System

1. Brake hand pump
2. Brake auto reset valve plunger

2.2-3 Base Control Console

This control console is located at the rear of the base. It contains the following controls:

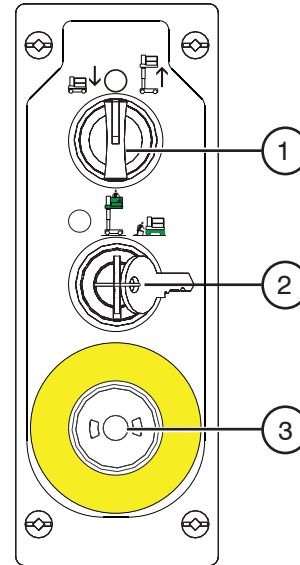

Figure 2-3. Base Control Console

1. **Lower/Neutral/Raise Switch** - This switch controls “↑” raising or “↓” lowering of platform.
2. **Off/Platform/Base Key Switch** - This three-way switch allows the operator to turn “○” off power to aerial platform or to activate either “↑” platform or “↓” base controls.
3. **Emergency Stop Button** - This button “●”, when depressed, disconnects power to the control circuit.

2.2-4 Motion Alarm

The alarm produces an audible sound when any control function is selected. On aerial platforms with certain options, a flashing amber light will accompany this alarm.

2.2-5 Emergency Lowering System

This emergency lowering system allows platform lowering in the event of an emergency or an electrical system failure.

1. Remove any obstructions from a lowering platform.
2. Extension platform may need to be retracted or aerial platform may need to be moved to clear obstruction. Refer to [Section 2.5](#) for winching and towing procedures.

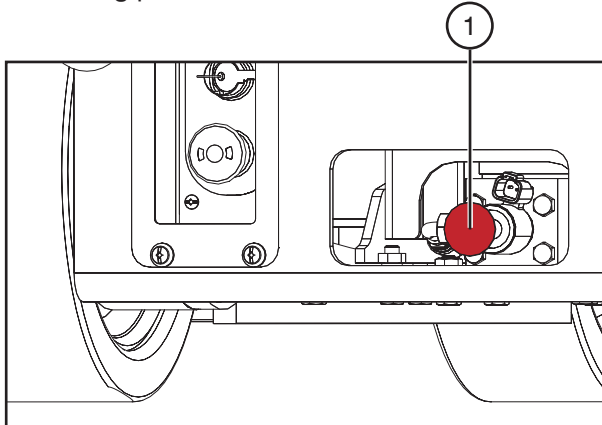

Figure 2-4. Emergency Lowering System

3. Locate emergency lowering valve (item 1) at the base of the lift cylinder, pull out and hold emergency lowering valve (item 1) to lower platform.

2.2-6 Tilt Alarm

The aerial platform is equipped with a device which senses when the aerial platform is out of level in any direction. When activated, it disables drive and lift functions of the aerial platform and an alarm produces an audible sound.



WARNING

If the tilt alarm sounds and the platform does not, or only partially raises, immediately lower the platform completely and ensure that the aerial platform is on a firm level surface.

2.2-7 Hourmeter

This hourmeter is located on the mast.

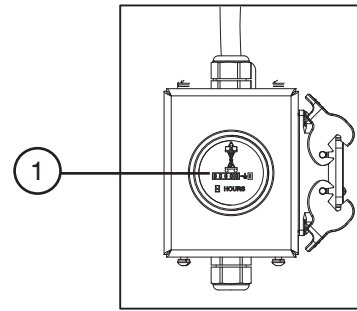

Figure 2-5. Hourmeter

1. This gauge records accumulated operating time of the aerial platform.

2.2-8 Circuit Breaker/Diagnostic Switch

This assembly is located inside the hydraulic/electrical compartment.

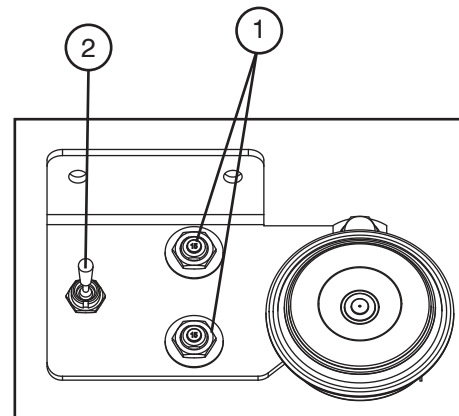

Figure 2-6. Circuit Breaker/Diagnostic Switch

1. In the event of power overload or positive circuit grounding, the circuit breaker pops out. Push breaker back in to reset.



WARNING

Diagnostic switch should not be used while any person are in the platform.

2. Diagnostic switch is used to check machine functionality while the machine is in the service position.

2.2-9 Platform Control Console

This removable control console is mounted at the right front of the platform. It contains the following controls:

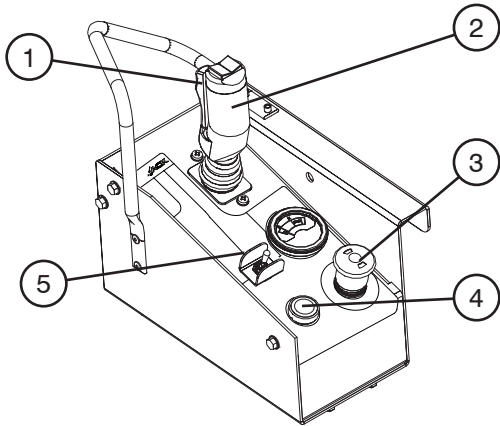





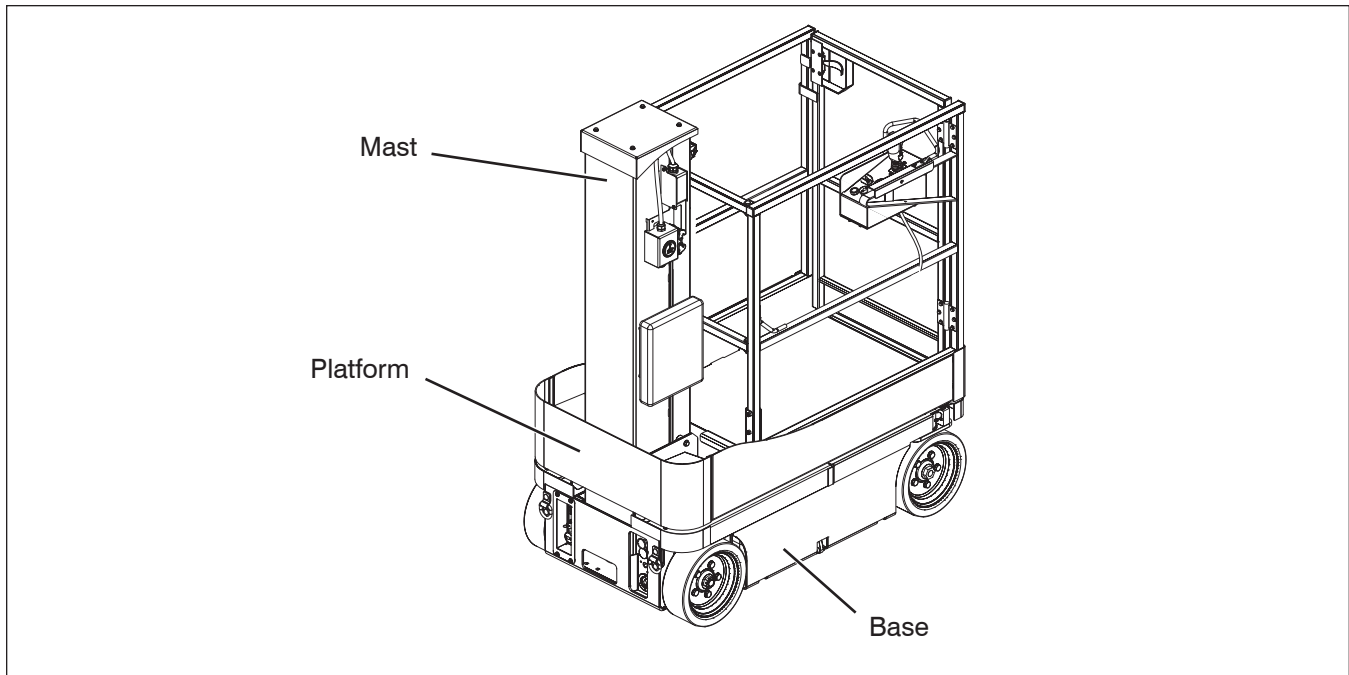

Figure 2-7. Platform Control Console

1. **Lift/Drive/Steer Enable Trigger Switch** - This momentary  switch energizes the controller. It must be held depressed continuously while engaging either the lift/drive or steer functions.
2. **Lift/Drive/Steer Controller** - This one-hand lever controls lift/drive and steer motions. Internal springs return it to neutral when controller is released.
3. **Emergency Stop Button/Operation Light** - This button , when depressed, disconnects power to the control circuit. The operation light indicates upper control availability. It glows when both emergency stop buttons on the platform control console and the base control console are pulled out.
4. **Horn Pushbutton** - This  pushbutton sounds an automotive-type horn.
5. **Lift/Off/Drive Switch** - Selecting "○" off position disconnects power from both lift and drive circuits.
 Selecting  lift position energizes the lift circuit.
 Selecting  drive position energizes the drive circuit.



IMPORTANT
If aerial platform is damaged or any unauthorized variation from factory-delivered condition is discovered, aerial platform must be tagged and removed from service.

Repairs to the aerial platform may only be made by a qualified service technician. After repairs are completed, the operator must perform visual and daily maintenance inspections & function tests again.

Scheduled maintenance inspections shall only be performed by qualified service technician (see [Table 4.6](#)).

2.3 Visual & Daily Maintenance Inspections

Begin the visual and daily maintenance inspections by checking each item in sequence for the conditions listed in this section.



WARNING

To avoid injury, do not operate an aerial platform until all malfunctions have been corrected.



WARNING

To avoid possible injury, ensure aerial platform power is off during your visual and daily maintenance inspections.

NOTE

While performing visual and daily inspections in different areas, be aware to also inspect limit switches, electrical and hydraulic components.



CAUTION

Ensure aerial platform is on a firm, level surface.

2.3-1 Labels

Refer to [Section 5 - Labels](#) in this manual and determine that all labels are in place and are legible.

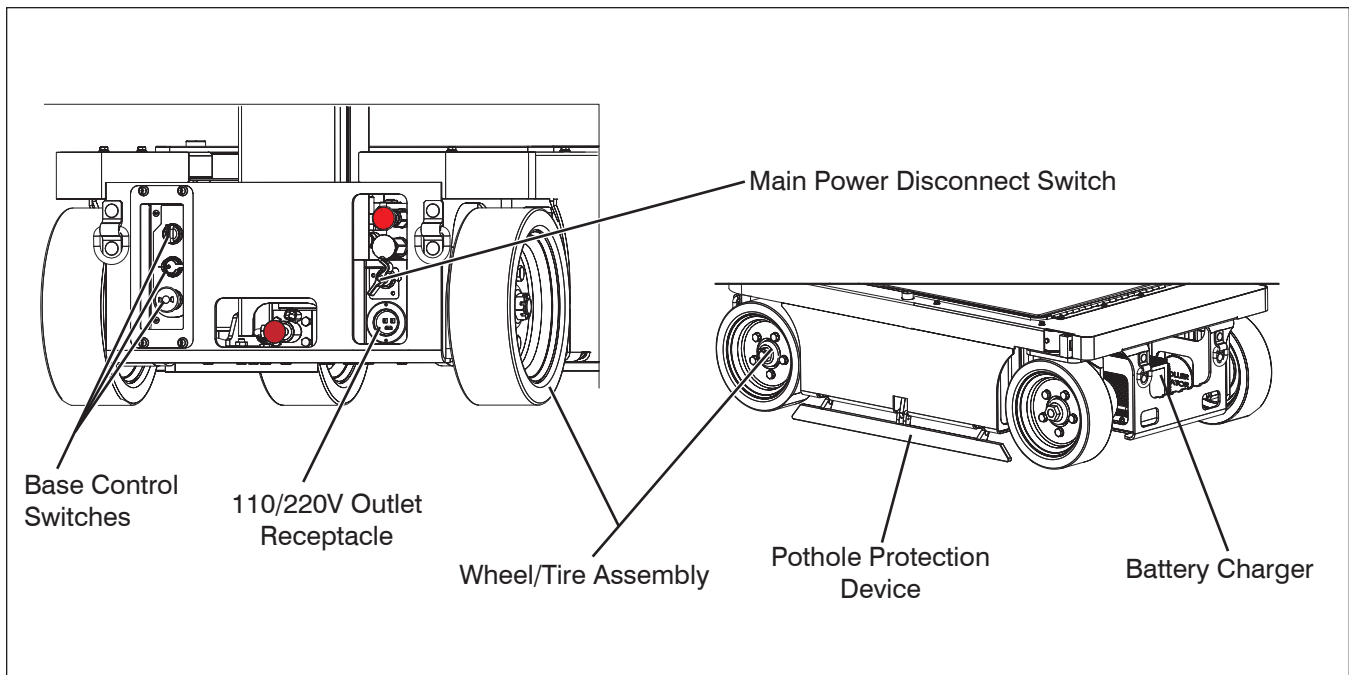

2.3-2 Electrical

Maintaining the electrical components is essential to good performance and service life of the aerial platform. Inspect the following areas for chafed, corroded and loose wires:

- all wiring harnesses
- hydraulic/electrical wiring harnesses

2.3-3 Limit Switches

Ensure limit switches are properly secured with no signs of visible damage and movement is not obstructed.

2.3-4 Hydraulic

Maintaining the hydraulic components is essential to good performance and service life of the aerial platform.

Perform a visual inspection around the following areas:

- hoses and fittings
- hydraulic cylinder
- all hydraulic manifolds
- the underside of the base
- ground area under the aerial platform

2.3-5 Base

- **Main Power Disconnect Switch**
 - Turn main power disconnect switch to “○” off position.
 - Ensure all cables are secure and switch is in proper working condition.
- **Base Control Switches**
 - Ensure there are no signs of visible damage and all switches are in their neutral positions.
- **110/220V Outlet Receptacle (If Equipped)**
 - Ensure receptacle is free from dirt and obstructions.
- **Battery Charger**
 - Ensure charger is secure and shows no visible damage.
- **Pothole Protection Device**
 - Ensure mechanisms have no sign of visible damage and are free from dirt and obstructions.
- **Wheel/Tire Assembly**

The aerial platform is equipped with solid rubber tires. Tire and/or wheel failure could result in an aerial platform tip-over. Component damage may also result if problems are not discovered and repaired in a timely fashion.

FAMILIARIZATION

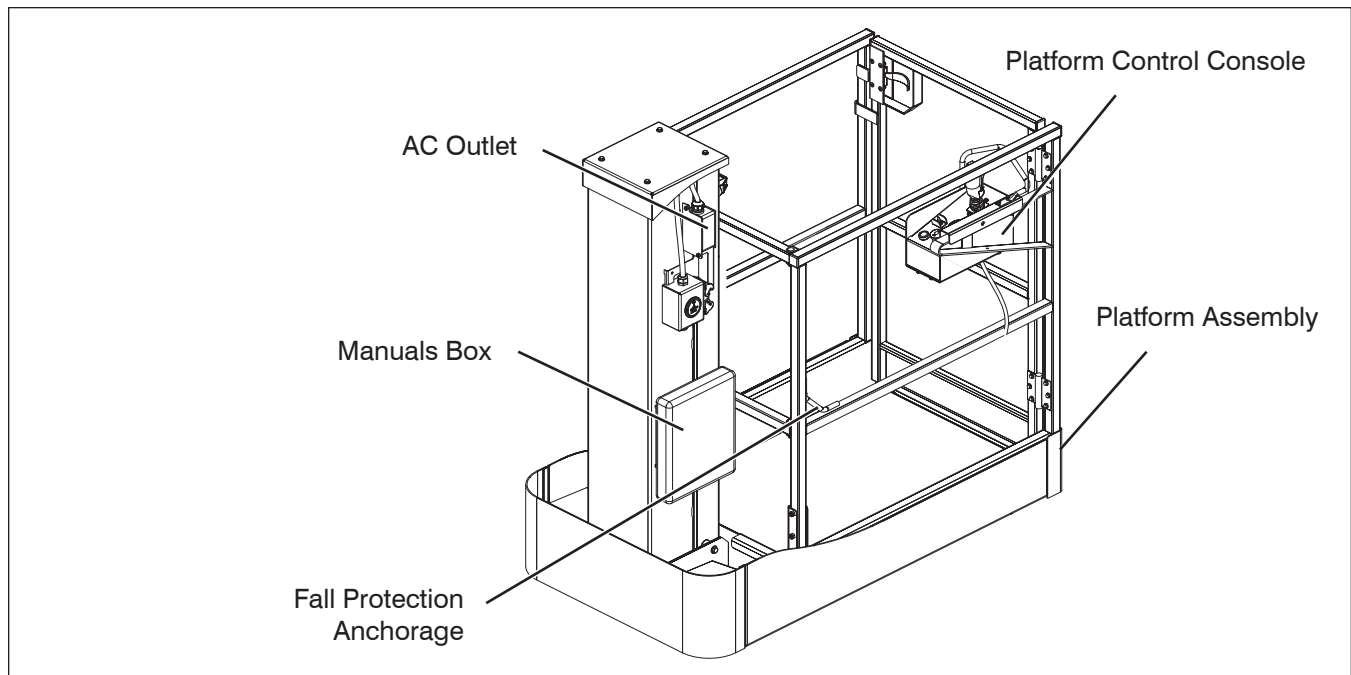

- Check all tire treads and sidewalls for cuts, cracks, punctures and unusual wear.
- Check each wheel for damage and cracked welds.
- Check each lug nut for proper torque to ensure none are loose.
- Check wheel motor assembly for loose or missing parts and signs of visible damage.
- Ensure wheels are aligned and true vertically and horizontally.

**WARNING**

Intermixing tires of different types or using tires of types other than those originally supplied with this equipment can adversely affect stability. Therefore, replace tires only with the exact Skyjack-approved type. Failure to operate with matched approved tires in good condition may result in death or serious injury.

2.3-6 Platform Assembly**WARNING**

Ensure that you maintain three points of contact to mount/dismount platform.

1. Open the gate (if equipped) and access the platform.
 2. Close the gate (if equipped).
 - Ensure all railings are properly positioned and secured.
 - Ensure all fasteners are securely in place.
 - Ensure gate (if equipped) is in good working order.
 - Ensure there are no loose or missing parts and there is no visible damage.
 - Ensure platform foot pedal is in good working order and no loose or missing parts and there is no visible damage.
- **Fall Protection Anchorage(s)**
 - Ensure anchorage(s) are secure and there is no visible damage.
 - **AC Outlet**
 - Ensure outlet has no visible damage and free from dirt or obstructions.

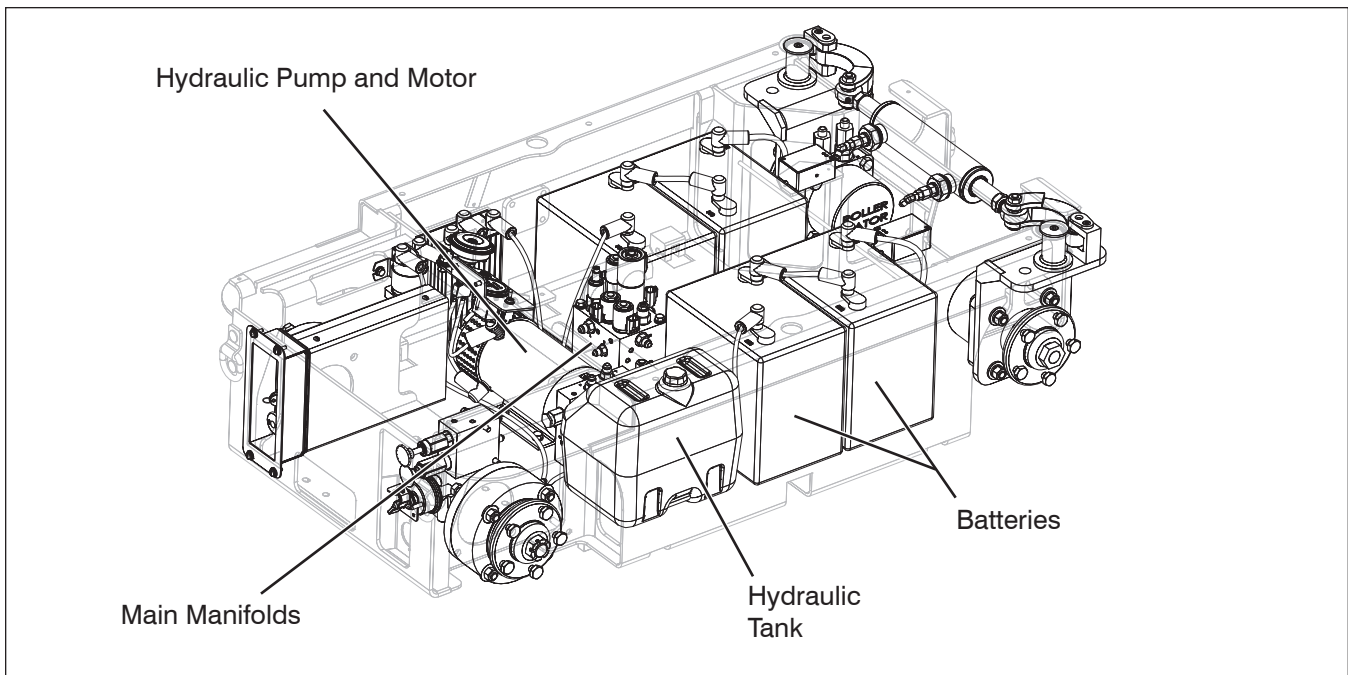

- **Platform Control Console**
 - Ensure all switches and controller are returned to neutral and are properly secured.
 - Ensure there are no loose or missing parts and there is no visible damage.



WARNING
 Ensure that you maintain three points of contact to mount/dismount platform.

3. Dismount from platform.
 4. Close the gate (if equipped).
- **Manuals**
 Ensure a copy of operating manual and certificate are enclosed in manual storage box.
 - Check to be sure manual storage box is present and in good condition.
 - Ensure manuals are legible and in good condition.
 - Always return manuals to the manual storage box after use.

2.3-7 Hydraulic/Electrical Compartment

1. To access the hydraulic/electrical compartment, refer to [Section 3.11](#).

- **Battery**
 Proper battery condition is essential to good performance and operational safety. Improper fluid levels or damaged cables and connections can result in component damage and hazardous conditions.



WARNING
 Explosion hazard. Keep flames and sparks away. Do not smoke near batteries.



WARNING
 Battery acid is extremely corrosive - Wear proper eye and facial protection as well as appropriate protective clothing. If contact occurs, immediately flush with cold water and seek medical attention.

- a. Check battery case for damage.
- b. Clean battery terminals and cable ends thoroughly with a terminal cleaning tool or wire brush.
- c. Ensure all battery connections are tight.
- d. If applicable, check battery fluid level. If plates are not covered by at least 1/2" (13 mm) of solution, add distilled or demineralized water.

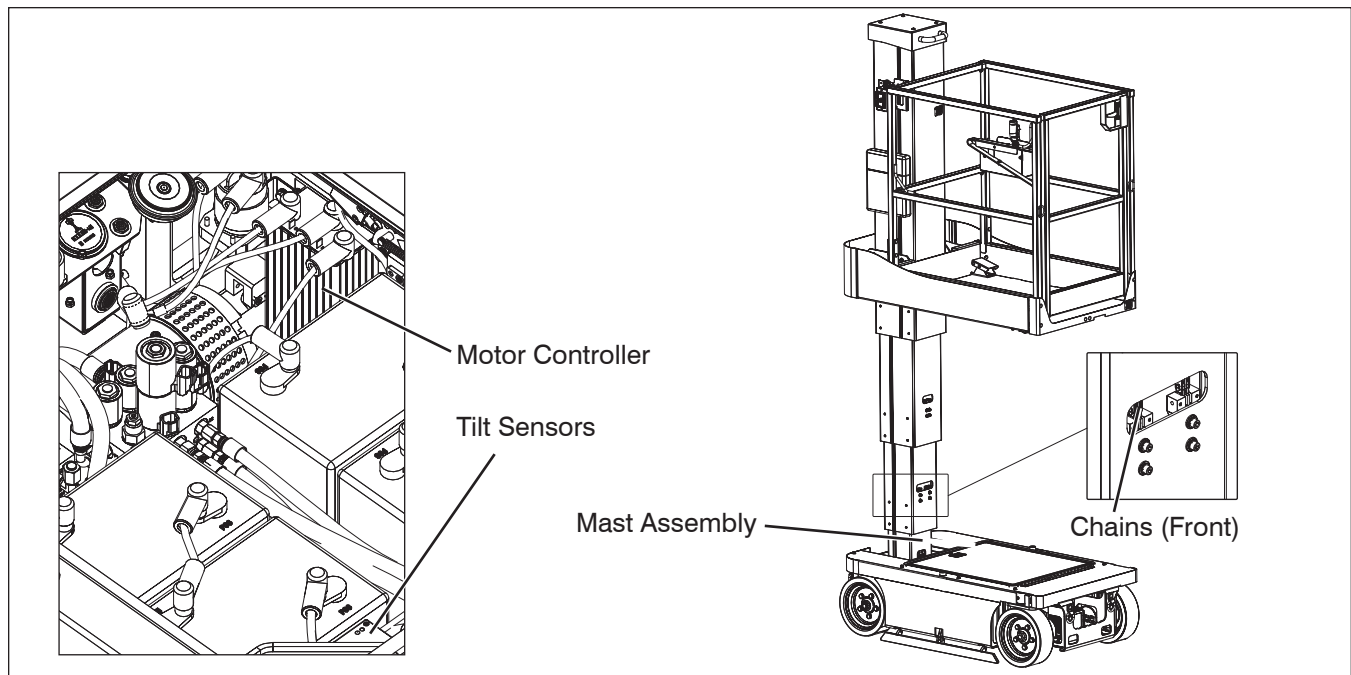

- e. Replace battery if damaged or incapable of holding a lasting charge.



WARNING
Use original or manufacturer-approved parts and components for the aerial platform.

- **Main Manifolds**
 - Ensure all fittings and hoses are properly tightened and there is no evidence of hydraulic leakage.
 - Ensure there are no loose wires or missing fasteners.
 - **Hydraulic Tank**
 - Ensure hydraulic filler cap is secure.
 - Ensure tank shows no visible damage and no evidence of hydraulic leakage.
 - **Hydraulic Pump and Motor**
 - Ensure there are no loose or missing parts and there is no visible damage.
 - **Hydraulic Oil**
 - Ensure hydraulic oil level is within the minimum (red line) and maximum (blue line) range found on the hydraulic oil level indicator label.
 - **Steer Cylinder Assembly**
 - Ensure steer cylinder assembly is properly secured and there are no loose or missing parts.
 - **Motor Controller**
 - Ensure the controller is properly secured and there is no visible damage.
 - Ensure there are no loose wires or missing fasteners.
 - **Tilt Sensors**
 - Ensure tilt sensors are properly secured and there is no visible damage.
 - **Limit Switches**
 - Ensure limit switches are properly secured with no signs of visible damage and movement is not obstructed.
2. Close the compartment access door and latch in place.
 3. Push the platform back to its operating position and latch in place.

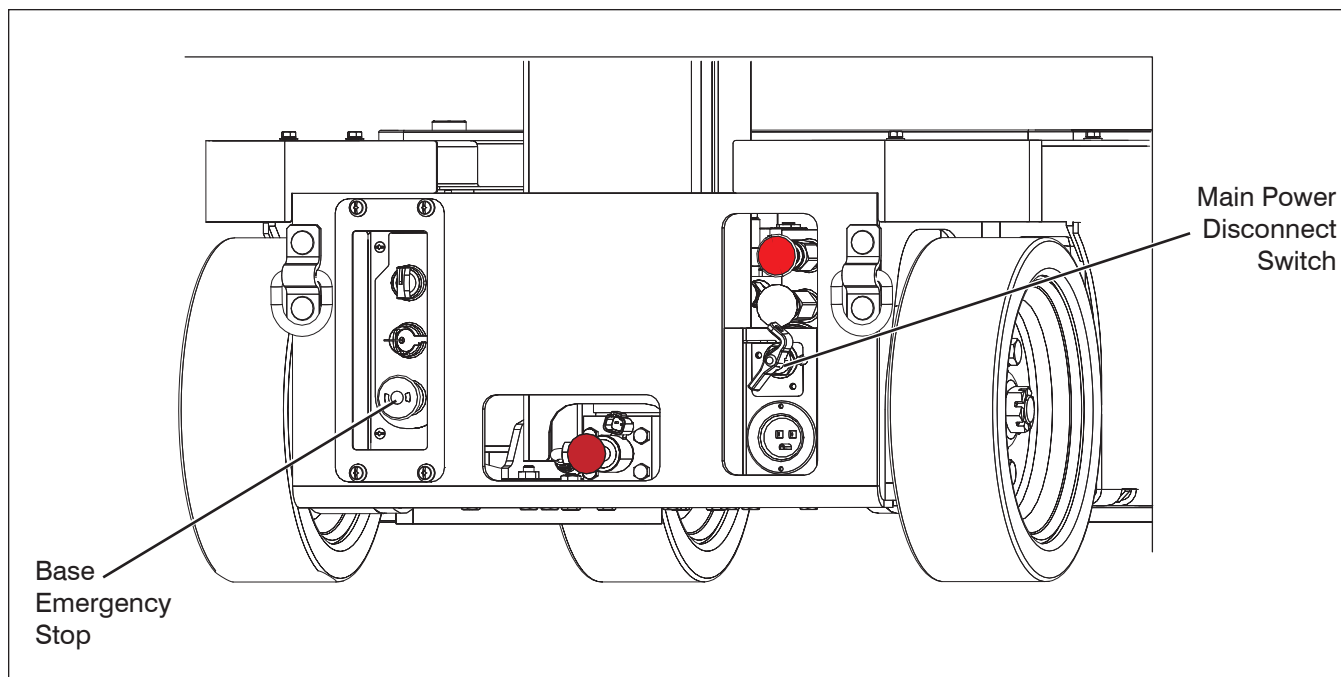

2.3-8 Lifting Mechanism

- **Mast Assembly**
 - Ensure mast assembly shows no visible damage and no signs of deformation in weldments.
- 1. Complete [Section 2.4 - Function Tests](#).
- 2. Raise the platform.
- **Wear Pads**
 - Ensure all bolts are tight, there is no visible damage to the wear pads and that no parts are missing.
- **Chains**
 - Ensure there are no missing parts, and all bolts are tight with no signs of visible damage.
 - Ensure chains are securely anchored.

2.3-9 Optional Equipment/Attachments

- **Flashing Light(s) (If Equipped)**
 - Ensure there are no loose or missing parts and there is no visible damage.
- **Pipe Rack (If Equipped)**
 - Ensure pipe rack assemblies are properly secured with no signs of visible damage.

2.4 Function Tests

Function tests are designed to discover any malfunctions before aerial platform is put into service. The operator must understand and follow step-by-step instructions to test all aerial platform functions.





Never use a malfunctioning aerial platform. If malfunctions are discovered, aerial platform must be tagged and placed out of service. Repairs to aerial platform may only be made by a qualified service technician.

After repairs are completed, operator must perform a pre-operation inspection and a series of function tests again before putting aerial platform into service.

Prior to performing function tests, be sure to read and understand [Section 3.8 - Start Operation](#).

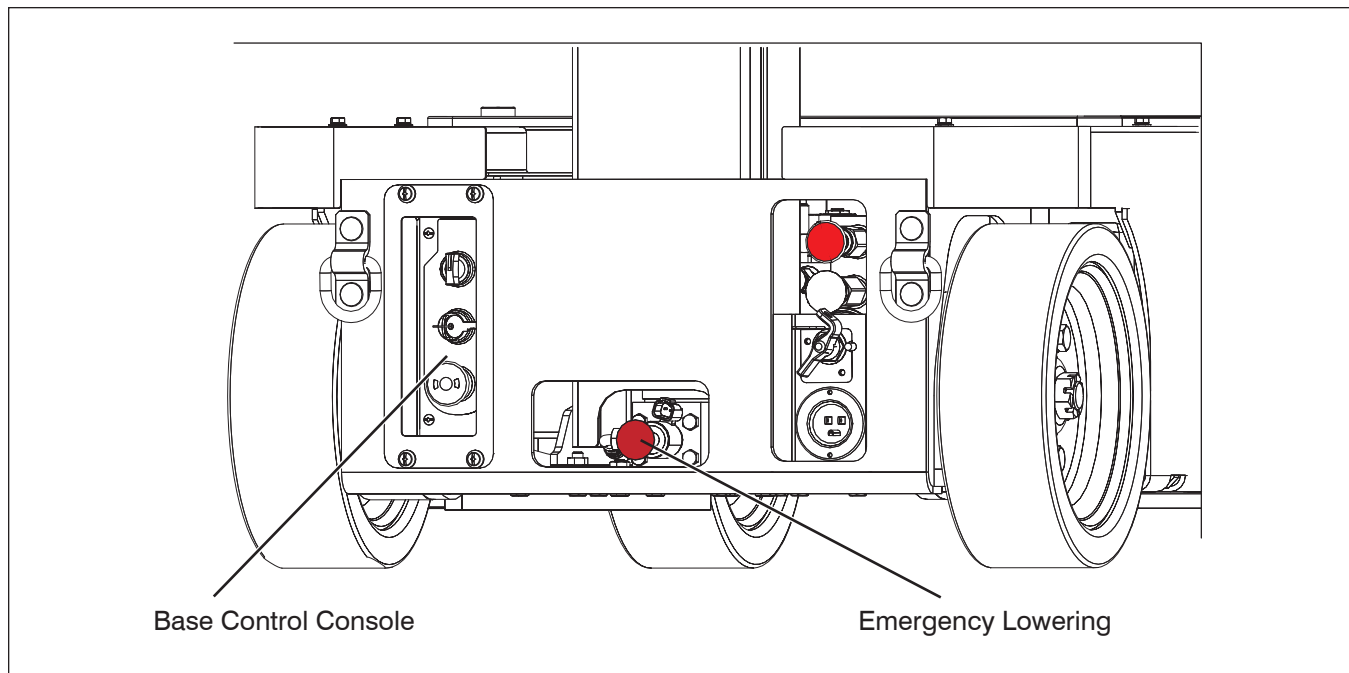

2.4-1 Test Main Power Disconnect Switch

1. On platform control console, pull out “” emergency stop button.
2. Pull out base “” emergency stop button.



3. At rear of the base, turn main power disconnect switch to “○” off position and attempt to activate all aerial platform functions.
Result: Aerial platform functions should not operate.

2.4-2 Base Control Console



1. Push in base “” emergency stop button.
 2. Turn main power disconnect switch to “|” on position.
- **Test Base Emergency Stop Light**
 1. Pull out base “” emergency stop button.
Result: Emergency stop light should continuously illuminate.
 - **Test Base Emergency Stop**
 1. Push in “” emergency stop button and attempt to raise or lower the platform.
Result: Platform raising and lowering functions should not operate.

- **Test Off/Platform/Base Switch**





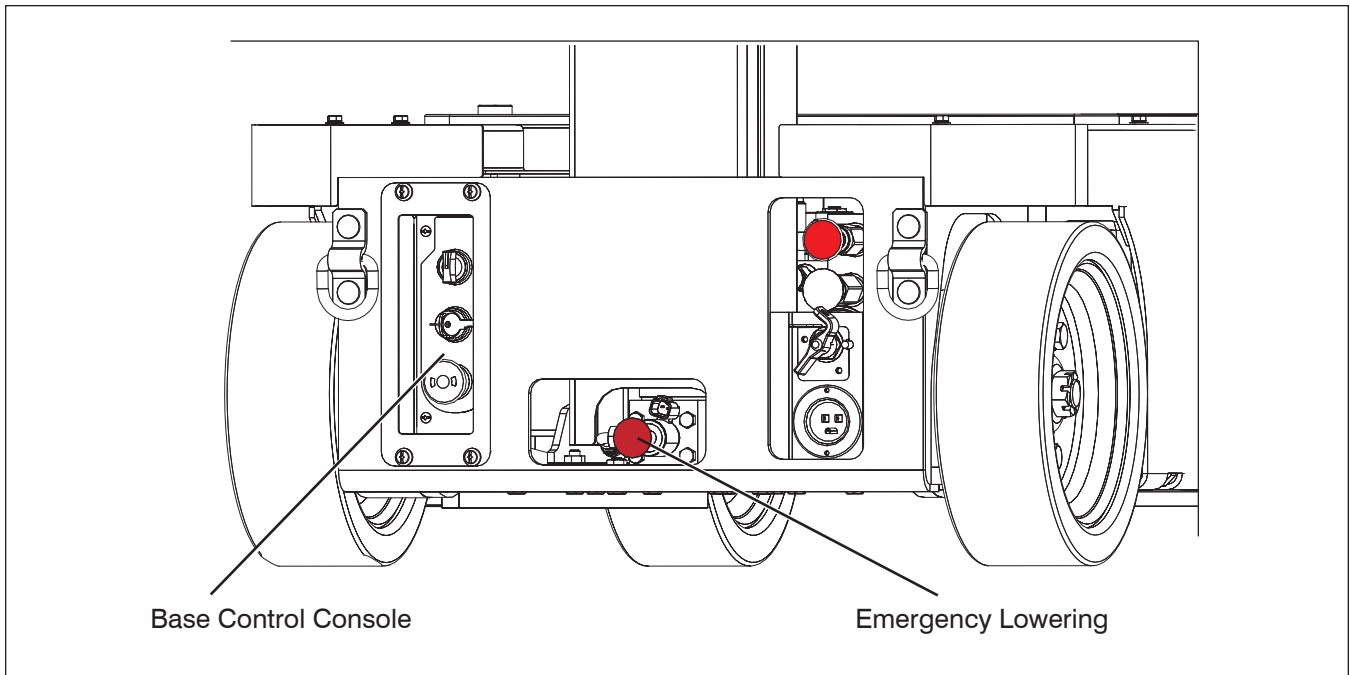

WARNING

Be aware of overhead obstructions or other possible hazards around the aerial platform when lifting.

1. Pull out base “” emergency stop button.
2. Select off/platform/base key switch to “○” off position. Attempt to raise or lower the platform.
Result: Platform raising and lowering functions should not operate.
3. Select off/platform/base key switch to “” platform position. Attempt to raise or lower the platform.
Result: Platform raising and lowering functions should not operate.



• Test Lower/Neutral/Raise Switch

1. Select and hold off/platform/base key switch to “” base position and “” raise the platform with lower/neutral/raise switch.
Result: Platform should rise.
2. Select and hold off/platform/base key switch to “” base position and “” lower the platform with lower/neutral/raise switch.
Result: Platform should lower.

• Test Emergency Lowering



WARNING
Be aware of overhead obstructions or other possible hazards around the aerial platform when lifting.

1. Raise the platform.
2. On rear of the base, pull out and hold emergency lowering valve to fully lower the platform.
Result: The platform should lower.

2.4-3 Test Platform Maintenance Limit Switch

1. Traverse the platform to maintenance position, refer to [Section 3.11](#).



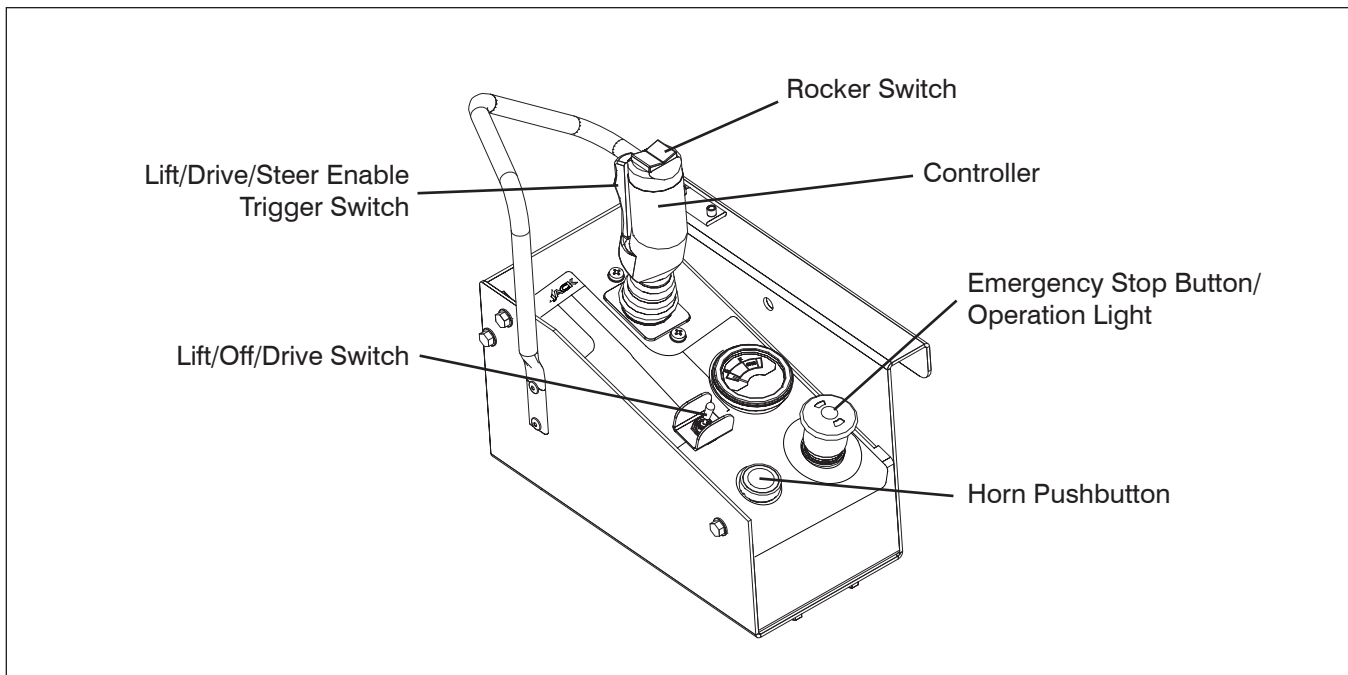

WARNING
Ensure that you maintain three points of contact to mount/dismount platform.

2. Open the gate (if equipped) and access the platform.
3. Close the gate (if equipped).
4. At the platform control console, attempt to activate any function.
Result: All functions should not operate.
5. Push the platform back to its operating position and latch in place.



2.4-4 Platform Control Console

1. Ensure main power disconnect switch is in “I” on position.
2. Ensure base “” emergency stop button is pulled out.
3. Select off/platform/base key switch to “” platform position.





WARNING



Ensure that you maintain three points of contact to mount/dismount platform.

4. Open the gate (if equipped) and access the platform.
5. Close the gate (if equipped).
6. On platform control console, pull out “” emergency stop button.

• Test Platform Emergency Stop

1. Push in “” emergency stop button and attempt to activate any platform function.
Result: All selected platform functions should not operate.
2. Pull out “” emergency stop button.
3. While activating any platform functions, push in emergency stop button.
Result: Current activated aerial platform function should immediately stop operating.

• Test Enable Trigger Switch



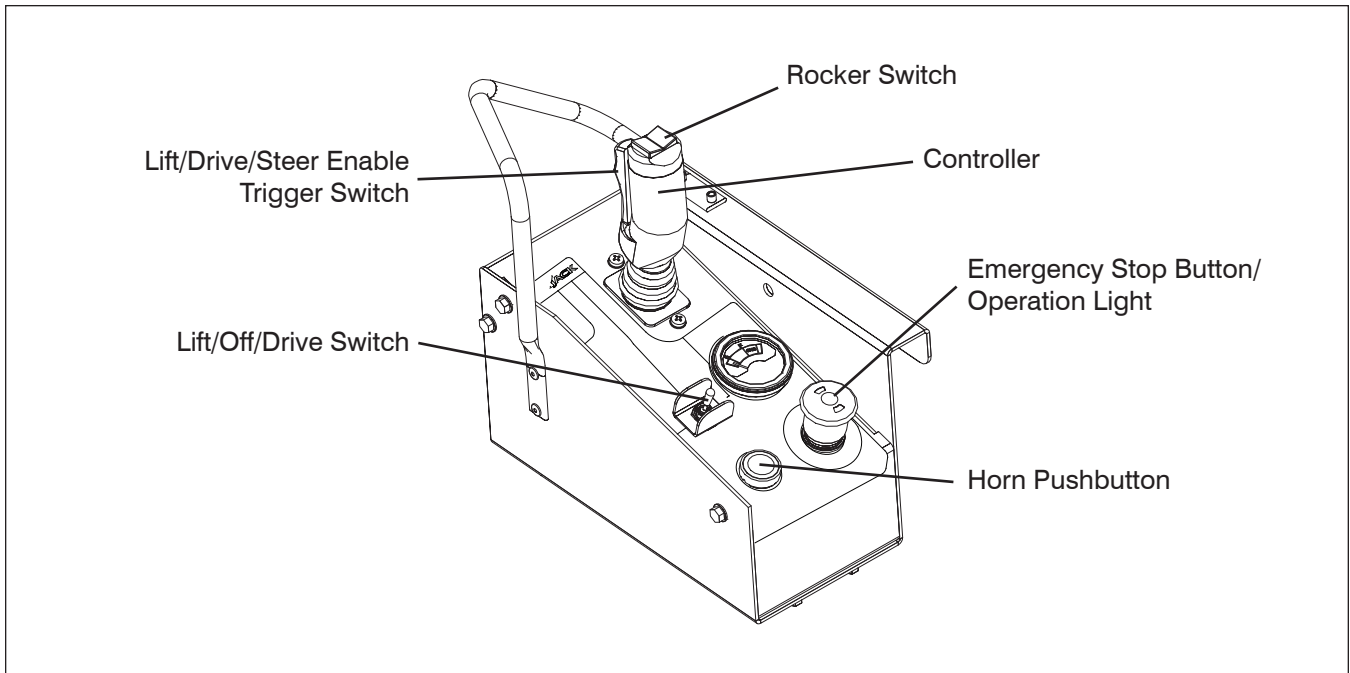



1. Pull out “” emergency stop button.
2. Without activating “” enable trigger switch, attempt to activate any platform function.
Result: All platform functions should not operate.









• **Test Lift/Off/Drive Switch Off Position**

1. Select lift/off/drive switch to “○” off position, attempt to activate any platform function.
Result: All platform functions should not operate.

• **Test Steering**

1. Select lift/off/drive switch to “” drive position.
2. Without activating “” enable trigger switch.
3. Press rocker switch on top of controller handle to “” left and “” right.
Result: Steer wheels should not operate.
4. Activate and hold “” enable trigger switch.
5. Press rocker switch on top of controller handle to “” left and “” right.
Result: Steer wheels should turn left and right.

• **Test Driving**



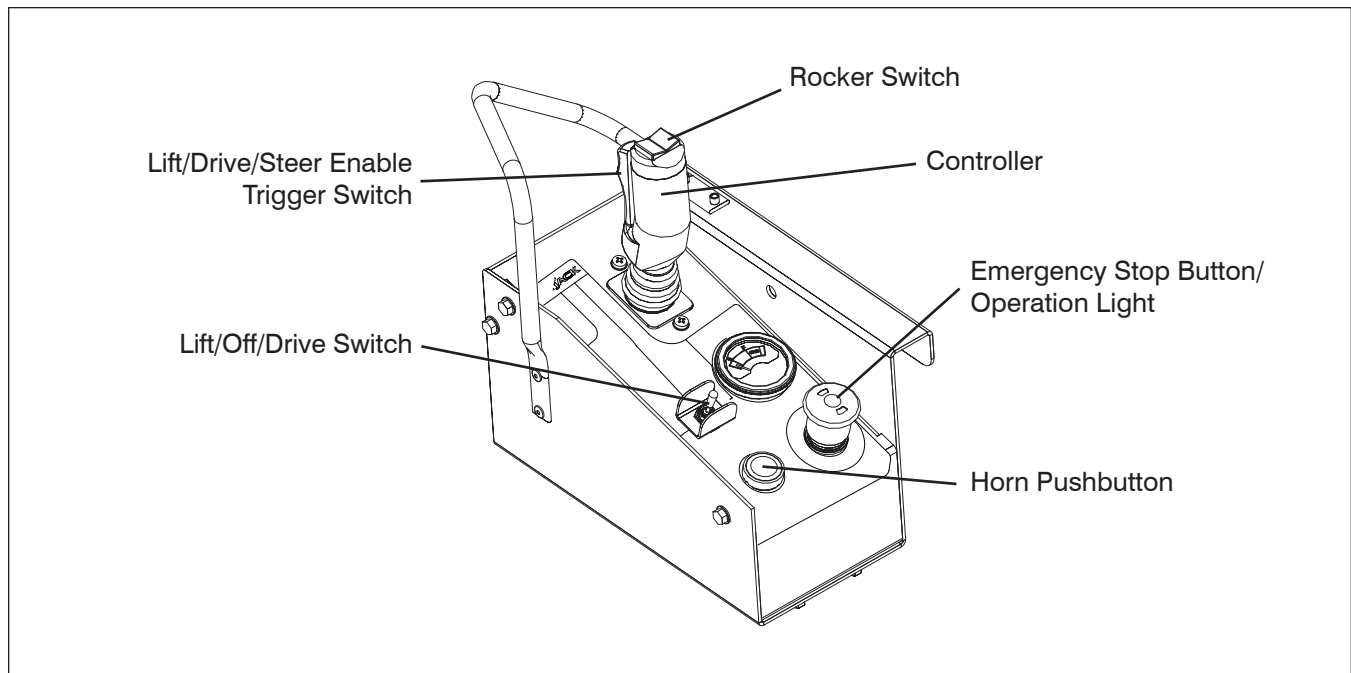



1. Ensure path of intended motion is clear.
2. Without activating “” enable trigger switch attempt to drive “” forward and reverse “”.
Result: Aerial platform drive functions should not operate.
3. Activate and hold “” enable trigger switch.
4. Slowly move controller handle in “” forward direction until aerial platform begins to move, and then return handle to center position.
Result: Aerial platform should move in forward direction, and then come to a stop.
5. Slowly move controller handle in “” reverse direction until aerial platform begins to move, and then return handle to center position.
Result: Aerial platform should move in reverse direction, and then come to a stop.



- Test Brakes

**WARNING**

Brakes will engage instantly when you release the controller handle, causing aerial platform to stop immediately.

1. Ensure path of intended motion is clear.
2. Activate and hold “” enable trigger switch.
3. Drive aerial platform “” forward and then “” backward. Test brake by releasing controller handle.
Result: Aerial platform should come to a stop. If aerial platform pulls to one side while stopping, do not operate aerial platform until brake adjustments have been checked.
4. Drive aerial platform “” forward and then “” backward. Test brake again by releasing “” enable trigger switch only.
Result: Aerial platform should come to an instant and abrupt stop. If aerial platform does not stop immediately, or if aerial platform pulls to one side while stopping, do not operate aerial platform until brake adjustments have been checked.



- Test Horn

1. Push “” horn pushbutton.
Result: Horn should sound.

- Test Platform Raising/Lowering

**WARNING**

Be aware of overhead obstructions or other possible hazards around the aerial platform when lifting.

1. Select lift/off/drive switch to “” lift position.
2. Without activating “” enable trigger switch attempt to lift/lower the platform.
Result: Aerial platform lift/lower functions should not operate.
3. Activate and hold “” enable trigger switch.
4. Push controller handle and raise the platform to an approximate height of 1 ft. (30.5 cm).
Result: Platform should rise.
5. Pull controller handle and lower the platform fully.
Result: Platform should lower.

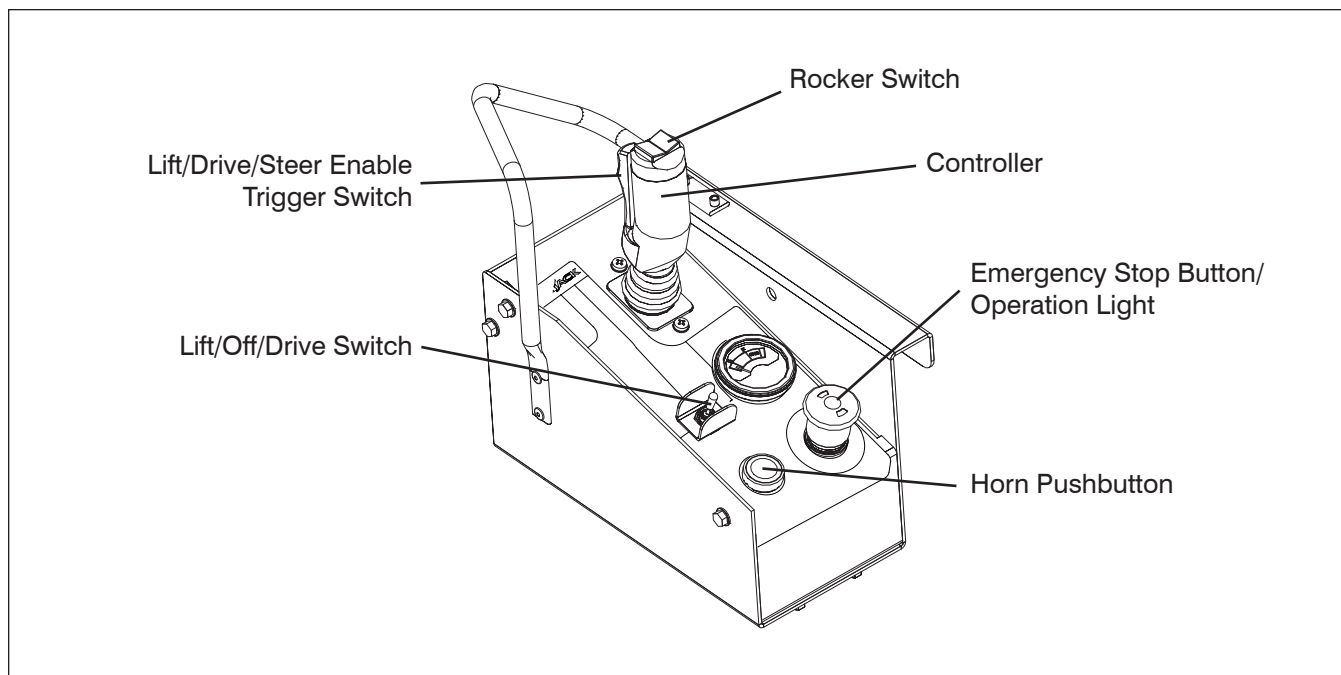

- Test Elevated Drive Speed



WARNING

Be aware of overhead obstructions or other possible hazards around the aerial platform when lifting.

1. Ensure path of intended motion is clear.
2. Raise the platform until approximately a height of 1 ft. (30 cm) is reached and attempt to drive forward or reverse.
Result: Aerial platform should move slower than when it was in stowed position.

- Test Pothole Sensor



WARNING

Ensure that you maintain three points of contact to mount/dismount platform.

1. Dismount from platform and place a block, approximately 1.5" (3.75 cm), under one side of the pothole protection device.
2. Open the gate (if equipped) and access the platform.
3. Close the gate (if equipped).

4. Raise the platform until approximately a height of 2 feet is reached and attempt to drive forward or reverse.
Result: Aerial platform should not move forward or backward.
5. Repeat the steps above with block placed under the other-side of the pothole protection device.
Result: Aerial platform should not move forward or backward.

2.4-5 Optional Equipment/Attachments

- Test Flashing Light (If Equipped)

1. Ensure path of intended motion is clear.
2. Activate any drive or lift functions.
Result: Light should flash.
3. Stop all platform motion.
Result: Light should stop flashing.

2.5 Winching and Towing Procedures

This section provides the operator with the Winching and Towing procedure, which includes instructions on how to manually release the brakes.



WARNING

Ensure platform is fully lowered before winching or towing. Sudden motion could cause the aerial platform to become unstable. Death or serious injury could result.



WARNING

In emergency situations where aerial platform functions are not available and lowering is impeded by an obstacle, utmost care must be taken to move aerial platform far enough to clear the obstacle. In such cases, operation must be extremely smooth with no sudden movements and must not exceed a speed of 2"/sec (50 mm/sec).



WARNING

When pushing, winching or towing, do not exceed 2 mph (3.2 km/h).



WARNING

Do not push, winch or tow aerial platform onto a slope, or brake the towing vehicle rapidly. Do not pull aerial platform down an incline towards a winch.

2.5-1 To Release Brakes Manually



WARNING

Do not manually disengage brakes if the aerial platform is on a slope.



WARNING

Brakes must be manually disengaged for pushing, winching or towing.

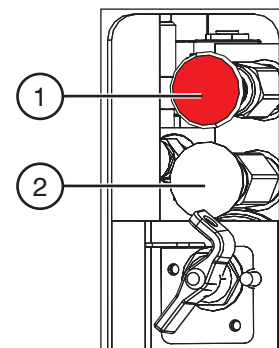

Figure 2-7. Brakes



WARNING

Brakes must be manually disengaged for pushing, winching or towing.

1. Ensure aerial platform is on level ground. Chock or block wheels to keep aerial platform from rolling.
2. Turn main power disconnect switch to "○" off position.
3. Locate the brake manifold at the rear of the base.
4. Push in brake auto reset valve plunger (item 2).
5. Grasp brake hand pump (item 1) and rapidly depress until firm resistance is felt. The brakes are now released.
6. Remove wheel chocks or blocks, then push, winch or tow aerial platform to desired location.
7. Position aerial platform on a firm and level surface.



WARNING

Brakes must be reengaged immediately after reaching the desired location.

8. Chock or block wheels to prevent aerial platform from rolling.
9. Reengage the brake by pulling out the brake auto reset valve plunger.

2.6 Emergency Lowering Procedure

This section guides the operator on how to use the emergency lowering system. This system allows platform lowering in the event of an emergency or an electrical system failure.



WARNING

Keep clear of lifting mechanism when using emergency lowering valve.

1. Remove any obstructions from a lowering platform.
2. Platform may need to be retracted or aerial platform may need to be moved to clear obstruction. Refer to [Section 2.5](#) for winching and towing procedures.

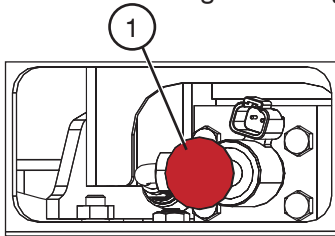

Figure 2-8. Emergency Lowering System

3. Locate the emergency lowering valve (item 1) at the base of the lift cylinder (rear of the base). Pull out and hold emergency lowering valve (item 1) to lower platform.

3.0 Operation

This section provides the necessary information needed to operate the aerial platform. It is important that the user reads and understands this section before operating the aerial platform.

3.1 General

In order for this aerial platform to be in good working condition, it is important that the operator meets the necessary qualifications and follow the maintenance and inspection schedule referred to in this section.

3.1-1 Operator Qualifications

- Only trained and authorized personnel shall be permitted to operate an aerial platform.
- Safe use of this aerial platform requires the operator to understand the limitations and warnings, operating procedures and operator's responsibility for maintenance. Accordingly, the operator must understand and be familiar with this operating manual, its warnings and instructions, and all warnings and instructions on the aerial platform.
- The operator must be familiar with employer's work rules and related government regulations and be able to demonstrate the ability to understand and operate this make and model of aerial platform in the presence of a qualified person.

3.1-2 Operator's Responsibility for Maintenance



WARNING

Maintenance must be performed by trained and competent personnel who are familiar with mechanical procedures.

Death or serious injury could result from the use of an aerial platform that is not properly maintained or kept in good working condition.

- The operator must be sure that the aerial platform has been properly maintained and inspected before using it.
- The operator must perform all the daily inspections and function tests found in [Table 4.6](#), even if the operator is not directly responsible for the maintenance of this aerial platform.

3.1-3 Maintenance and Inspection Schedule

- The inspection points covered in [Table 4.6](#) indicate the areas of the aerial platform to be maintained or inspected and at what intervals the maintenance and inspections are to be performed.
- The actual operating environment of the aerial platform may affect the maintenance schedule.



WARNING

Use original or manufacturer-approved parts and components for the aerial platform.

3.1-4 Owner's Inspections

It is the responsibility of the owner to arrange daily, quarterly (or 150 hours) and annual inspections of the aerial platform. Refer to [Table 4.6](#) for recommended maintenance and inspection areas and intervals. A record of annual inspection is kept on a label located on the mast. Refer to [Table 4.2](#) in this manual.

3.2 Major Components

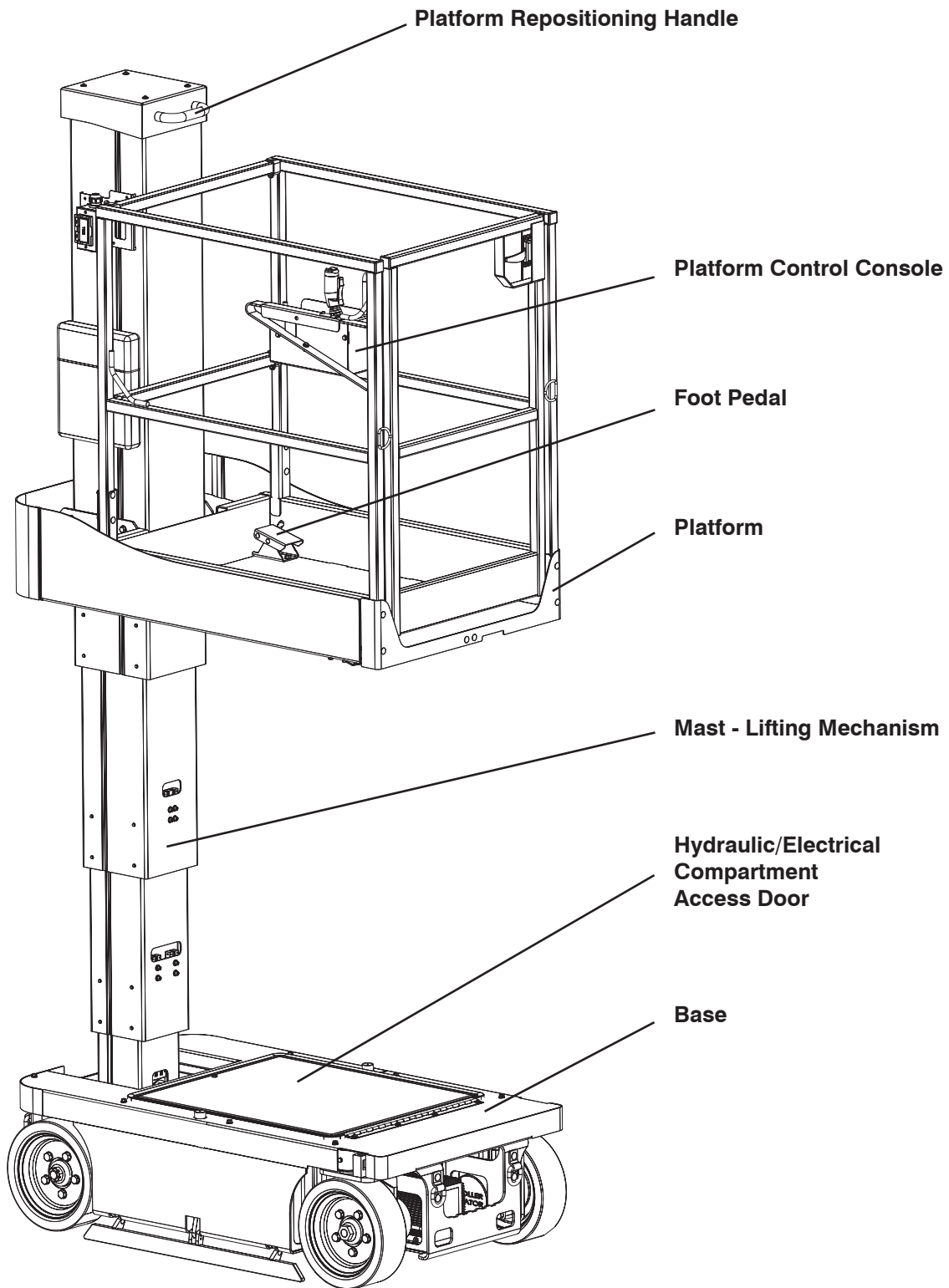

SKYJACK Vertical Mast Series Aerial Platform

3.3 Major Assemblies

The aerial platform consists of three major assemblies: base, lifting mechanism and platform.

3.3-1 Base

The base is a rigid, one-piece weldment which contains hydraulic, electrical components and four (4) 6 volt batteries. The front wheels are driven by hydraulic motors, steerable by a hydraulic cylinder. The rear wheels are non-driven, with spring-applied hydraulically released brakes.

3.3-2 Lifting Mechanism

The lifting mechanism is constructed of formed steel. The Mast assembly is raised and lowered by a series of chains and a single-acting hydraulic lift cylinder with holding valves. A pump, driven by an electric motor, provides hydraulic power to the lift cylinders.

3.3-3 Platform

The platform is constructed of a tubular support frame, a skid-resistant "diamond plate" deck surface and 43.25" fixed guardrails with 6" toe boards and mid-rails. The platform can be entered from the front through a spring-returned gate with latch (if equipped).

3.4 Serial Number Nameplate

The serial number nameplate, located at the rear of the aerial platform, lists the following:

- Model number
- Serial number
- Aerial platform weight
- Maximum drivable height
- Maximum capacities
- Maximum number of persons permissible on the platform
- Voltage
- System pressure
- Lift pressure
- Maximum platform height
- Maximum wheel load
- Date manufactured

3.5 Component Identification

The following descriptions are for identification, explanation and locating purposes only.

3.5-1 Manual Storage Box

This weather-resistant box is mounted on the Mast. It contains operating manual and certificate.

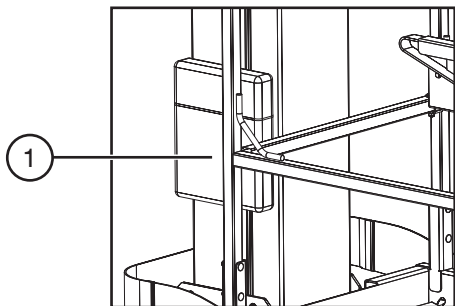

Figure 3-1. Manual Storage Box

1. The operating manual for this make and model of aerial platform must remain with the aerial platform and should be stored in this box.

3.5-2 AC Outlet on Platform

This outlet is a source of AC power on the platform.

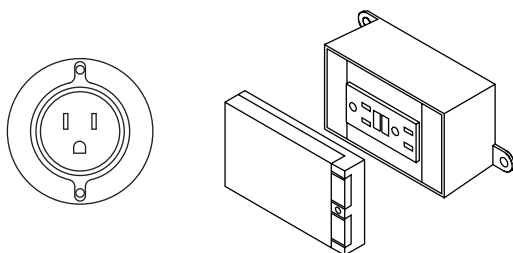

Figure 3-2. AC Outlet on Platform

3.5-3 Battery Charger

The charger is located at the front of the base. Refer to [Section 3.12a-2](#) or [Section 3.12b-2](#) for battery-charging operation.

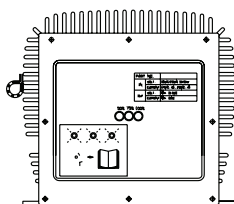

Figure 3-3a. Battery Charger

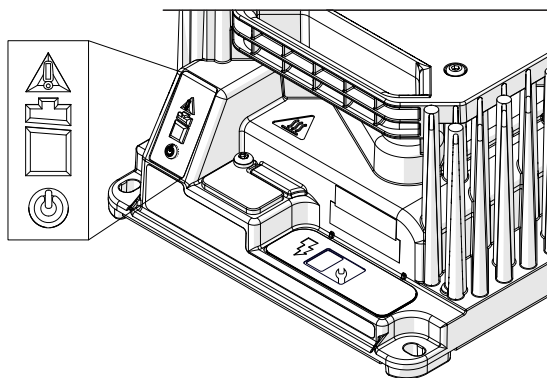

Figure 3-3b. Battery Charger

3.5-4 Pothole Protection Device

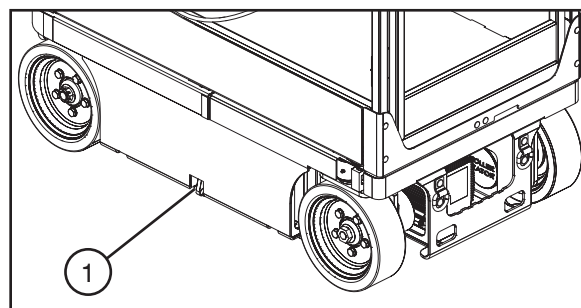

Figure 3-4. Pothole Protection Device

1. **Pothole Protection Device** - This device consists of a set of mechanically actuated steel weldments located under the base. These weldments will automatically rotate for reduced ground clearance when elevating the aerial platform. If the pothole protection device has not fully lowered, the drive function will be disabled.



WARNING

Crushing Hazard - Personnel on ground must stay clear of pothole protection device.



WARNING

Do not drive elevated in areas where electrical cords or debris are in the path of travel.

Maintenance of the Pothole Protection Device

As with all safety devices, periodic inspection and maintenance is required to ensure the proper operation of the pothole protection device. This mechanism is designed to reduce ground clearance and assist in the stability of an elevated aerial platform in the event the aerial platform encounters a “drop-off” or “pothole.” The nature of this safety feature relies on maintaining a consistent ground clearance, therefore, if the aerial platform ever does come to rest on the pothole device, the platform should be immediately lowered and “locked out” to prevent further use until a complete inspection of the mechanism is performed by a qualified technician.

3.5-5 Platform Maintenance Lock Mechanism

This locking mechanism is located underneath the platform.

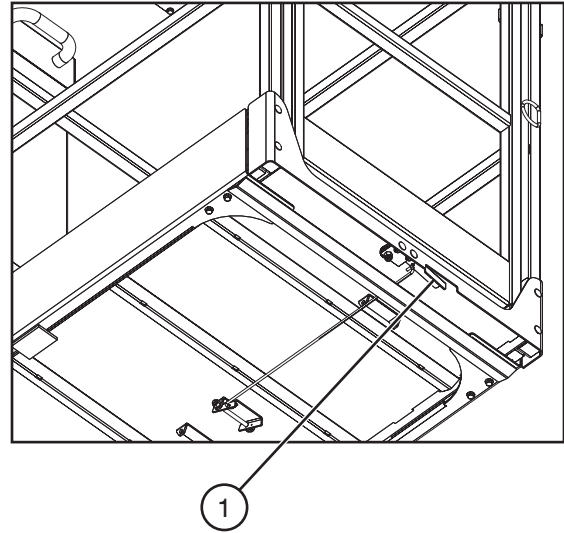

Figure 3-5. Platform Maintenance Lock

1. The aerial platform is equipped with a maintenance lock mechanism. When engaged, it allows access to the hydraulic/electrical compartment. During this access, it disables all functions.



CAUTION

Aerial platform motion can occur when engaging diagnostic switch.

2. Hydraulic functions can be enabled by engaging the diagnostic switch.

3.6 Component Identification (Optional Equipment/Attachments)

The following descriptions are for identification, explanation and locating purposes only.

3.6-1 Flashing Light (If Equipped)

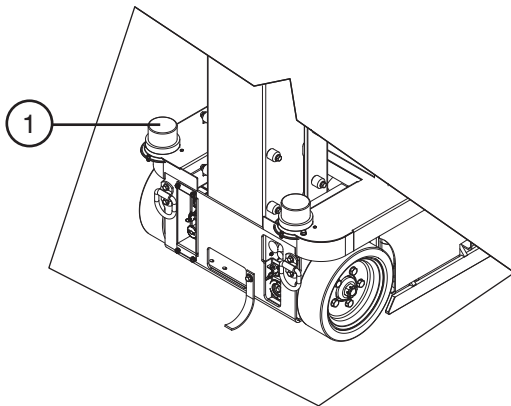

Figure 3-7. Flashing Light

1. **Flashing Light Option** - This light is attached to the base of the platform and flashes when any movement control is activated.

3.6-2 1200W AC Inverter (If Equipped)

The inverter is located on the base of the aerial platform. It has the following controls:

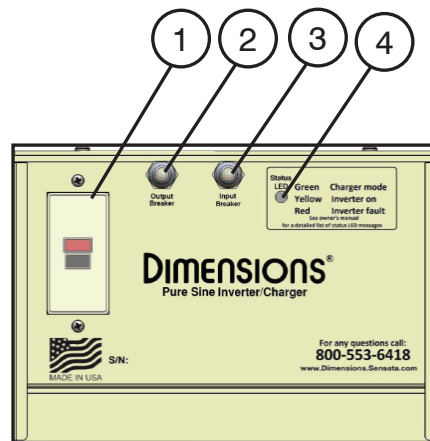

Figure 3-8. 1200W AC Inverter

NOTE

The inverter operation is automatic. These controls do not need to be manipulated for normal operation.

NOTE

The inverter has a thirty-minute timed cut-out. If no control function (except lowering) is activated within 30 minutes, the inverter will shut off.

1. **GFCI Outlet** - During inverter operation, this outlet provides AC power.
2. **Output Breaker** - In the event of a power overload or circuit grounding, the circuit breaker pops out. Press the breaker back in to reset.
3. **Input Breaker** - Protects the input circuitry.
4. **Status LEDs** - These LEDs indicate the operating or fault status of the inverter.

3.5-6 Fall Protection Anchorage

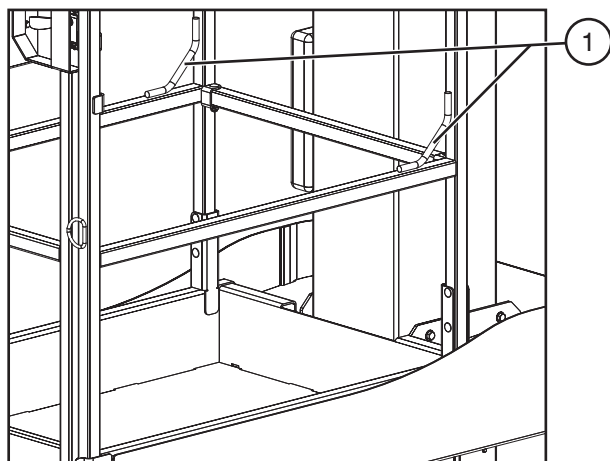

Figure 3.6. Fall Protection Anchorage

1. **Fall Protection Anchorage** - Use this as an attachment point for a fall restraint system. Do not attach anchorage connectors to any other point on the platform. Do not use this to lift, anchor, secure or support the platform or any other apparatus or material.

**WARNING**

The fall protection anchorage is to be used for restraint, within the limits of the platform, only.

3.7 Operator's Responsibility

It is the responsibility of the operator, prior to each work shift, to perform the following:

1. Visual and Daily Maintenance Inspections

- are designed to discover any damage of components before the aerial platform is put into service.
- are done before the operator performs the function tests.

**WARNING**

Failure to locate and repair damage, and discover loose or missing parts may result in an unsafe operating condition.

2. Function Tests

- are designed to discover any malfunctions before the aerial platform is put into service.

IMPORTANT

The operator must understand and follow the step-by-step instructions to test all aerial platform functions.

The operator should make a copy of the Operator's Checklist (see [Table 4.7](#)) and fill out the visual and daily maintenance inspections and the function tests sections while performing the items outlined in [Section 2.3](#) and [Section 2.4](#).

3.8 Start Operation

Carefully read and completely understand the operating manual and all warnings and instruction labels (refer to [Section 5 - Labels](#)) on the aerial platform.



WARNING

Do not operate this aerial platform without proper authorization and training. Failure to avoid this hazard could result in death or serious injury.

Before operating this aerial platform, perform the following steps:

1. Visual and daily maintenance inspections (see [Section 2.3](#))
2. Function tests (see [Section 2.4](#))
3. Job site inspection
It is the responsibility of the operator to perform a job site inspection and avoid the following hazardous situations:
 - holes or drop-offs
 - ditches or soft fills
 - floor obstructions, bumps or debris
 - overhead obstructions
 - electrical cords, hoses and high voltage conductors
 - hazardous locations
 - inadequate surface support to withstand all load forces imposed by the aerial platform
 - wind and weather conditions
 - the presence of unauthorized personnel
 - other possible unsafe conditions



WARNING

An operator should not use any aerial platform that:

- **does not appear to be working properly.**
- **has been damaged or appears to have worn or missing parts.**
- **has alterations or modifications not approved by the manufacturer.**
- **has safety devices which have been altered or disabled.**



Failure to avoid these hazards could result in death or serious injury.

3.8-1 To Activate Base Control Console



WARNING

Ensure that you maintain three points of contact to mount/dismount platform.

1. Open the gate (if equipped) and access the platform.
2. Close the gate (if equipped).
3. On platform control console, pull out “” emergency stop button.
4. Dismount from platform.
5. Turn main power disconnect switch to “|” on position.
6. On base control console, pull out “” emergency stop button.

3.8-2 To Raise or Lower Platform Using Base Control Console





WARNING

Be aware of overhead obstructions or other possible hazards around the aerial platform when lifting.





WARNING

Do not lower the platform unless the area is clear of personnel and obstructions.

1. Select and hold off/platform/base key switch to “” base position.
2. Select and hold lower/neutral/raise switch to either “” raise or “” lower position. Release switch to stop.

3.8-3 To Activate Platform Control Console

1. Turn main power disconnect switch to “I” on position.
2. On base control console, pull out “” emergency stop button.
3. Select base/off/platform key switch to “” platform position.

**WARNING**

Ensure that you maintain three points of contact to mount/dismount platform.



4. Open the gate (if equipped) and access the platform.
5. Close the gate (if equipped).
6. On platform control console, pull out “” emergency stop button.

3.8-4 To Raise or Lower Platform Using Platform Control Console**WARNING**

Be aware of overhead obstructions or other possible hazards around the aerial platform when lifting.

**WARNING**

Do not lower the platform unless the area below is clear of personnel and obstructions.

1. On platform control console, select lift/off/drive switch to “” lift position.
2. Activate and hold “” enable trigger switch.
3. Move controller handle forward or backward until desired height is reached.

4. Return controller to neutral center position to stop. Release “” enable trigger switch.

**WARNING**

To protect against unintended movement of the aerial platform, push in the emergency stop button after you have arrived at your desired location or elevation.

NOTE





If the tilt alarm sounds and the platform does not, or only partially raises, immediately lower the platform completely and ensure that the aerial platform is on a firm level surface.

3.8-5 To Drive Forward or Backward**WARNING**

Be aware of blind spots when operating the aerial platform.

**WARNING**



Ensure that there are no personnel or obstructions in the path of travel, including blind spots.

1. On platform control console, select lift/off/drive switch to drive “” position.
2. Activate and hold “” enable trigger switch.
3. Move controller handle “” forward/up or “” backward/down to desired speed and direction of aerial platform travel.
4. Return controller to neutral center position to stop. Release “” enable trigger switch.

**WARNING**

To protect against unintended movement of the aerial platform, push in the emergency stop button after you have arrived at your desired location or elevation.

3.8-6 To Steer

1. On platform control console, select lift/off/drive switch to drive “” position.
2. Activate and hold “” enable trigger switch.
3. Press “” rocker switch on top of controller handle in either direction to steer.

NOTE



Steering is not proportional. Driving and steering may be active at the same time.

3.8-7 Shutdown Procedure

1. Completely lower the platform.
2. On platform control console, push in “” emergency stop button.

**WARNING**

Ensure that you maintain three points of contact to mount/dismount platform.

3. Dismount from platform.
4. On base control console, push in “” emergency stop button.
5. On base control console, select off/platform/base key switch to “” off position and remove the key.
6. Turn main power disconnect switch to “” off position.

3.9 Loading/Unloading

Know and heed all national, state or territorial/provincial and local rules which apply to your loading/unloading of aerial platforms.

Only qualified personnel shall operate the aerial platform during loading/unloading.

Be sure vehicle capacity and loading equipment hoists, chains, straps, etc., are sufficient to withstand maximum aerial platform weight.

The transport vehicle must be parked on a level surface and must be secured to prevent rolling while aerial platform is being loaded/unloaded.

3.9-1 Driving

Before driving the aerial platform:

- Ramp or dock capacity should be sufficient to withstand maximum aerial platform weight.
- Ramp should be equipped with side guards to prevent inadvertent fall from the ramp.
- Incline should not exceed aerial platform gradeability, as illustrated in [Figure 3-10](#).
- Aerial platform brakes should be checked for proper operation.



WARNING

When transporting, the aerial platform must be secured to the truck or trailer deck. Tie downs are available as illustrated in [Figure 3-9](#).

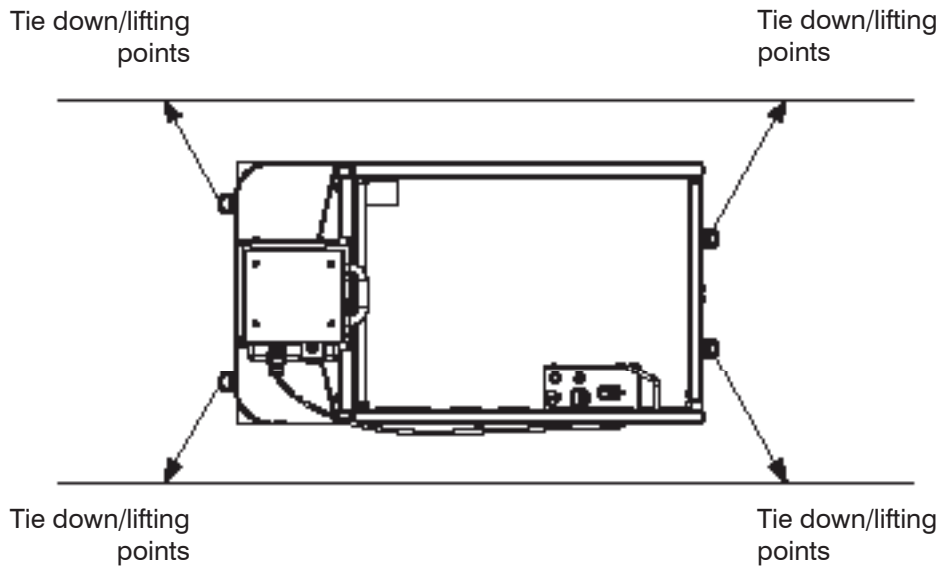
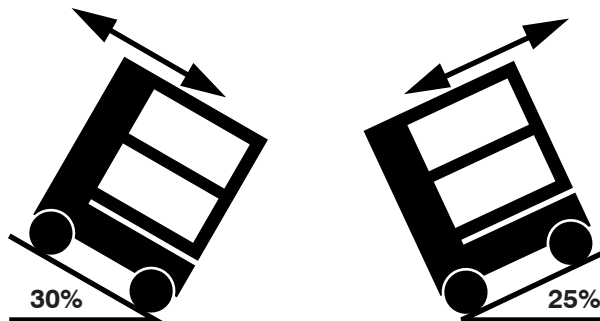

Figure 3-9. Tie Downs/Lifting Points



Gradeability 30%: Climbing reverse - Descending forward
 Gradeability 25%: Climbing forward - Descending reverse

Figure 3-10. Maximum Gradeability of Inclined Driving

3.9-2 Lifting



WARNING

Only qualified rigger shall operate machinery during lifting.

When it is necessary to lift the aerial platform, the following conditions must be met:

- The platform must be fully lowered.
- The main power disconnect switch must be in “○” off position.
- The traversing platform must be retracted and secured.
- The platform control console must be secured to the railing or removed.
- The platform must be cleared of all personnel, tools and materials.
- The lifting/rigging must be attached to all four lifting points as illustrated in Figure 3-9.

- An appropriate spreader bar and straps/chains or other suitable lifting devices may be used during lifting. Refer to Figure 3-11 for an example of an appropriate lifting method.

IMPORTANT

Using an inappropriate lifting method, as shown in Figure 3-12, may result in damage to the aerial platform.

- The aerial platform can be lifted with a forklift from the sides. Lift with forks in designated forklift lifting locations as illustrated in Figure 3-13.

NOTE

The mass of the aerial platform is as per Table 4.3. The center of gravity is approximately located in the middle of the aerial platform, front to back and side to side, as illustrated in Figure 3-13. Vertically, the center of gravity is approximately just above the base chassis.

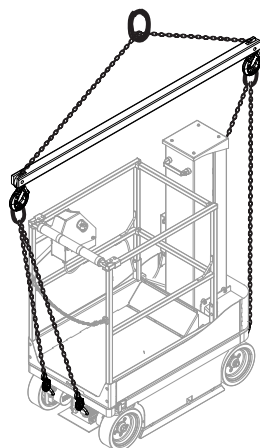

Figure 3-11. Appropriate Lifting Method

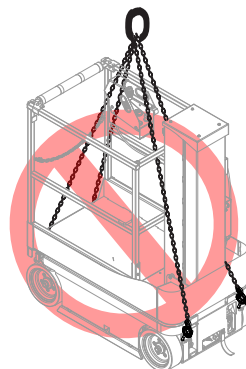

Figure 3-12. Inappropriate Lifting Method

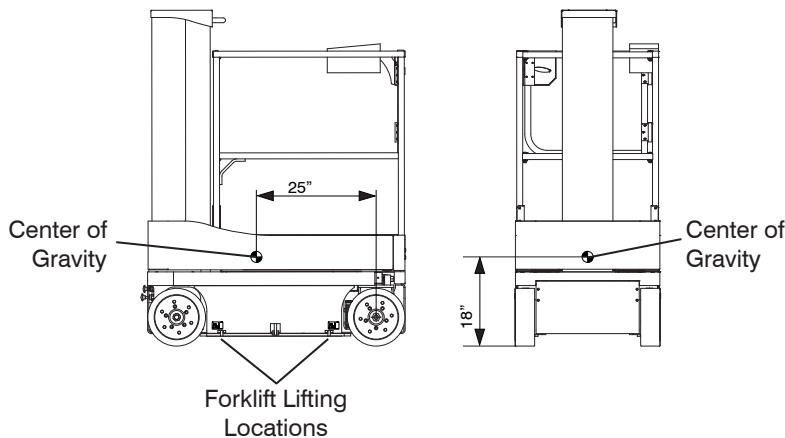

Figure 3-13. Center of Gravity/Forklift Lifting Locations

3.10 Platform Traversing

1. To traverse platform, step on the foot pedal on the platform (item 1) and grasp the platform repositioning handle (item 2) then carefully push/pull the platform until desired location is reached.

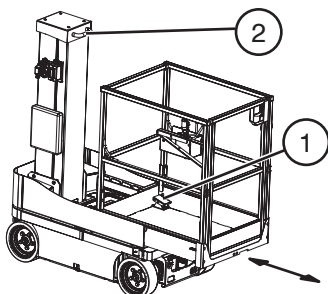

Figure 3-14. Traversing Platform

2. Ensure foot pedal (item 1) rests in one of the locking slots.

3.11 Accessing the Hydraulic/Electrical Compartment

1. Ensure aerial platform is on firm and level ground.
2. Fully lower the platform into stowed position.



CAUTION

The following procedure must be done from outside of the platform.

3. Depress foot pedal on the platform (item 1), then pull platform as far as possible towards maintenance position.

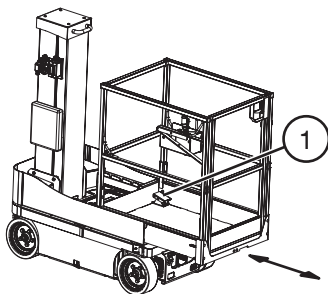

Figure 3-15. Traversing Platform

4. Locate platform maintenance locking mechanism underneath the platform.
5. Unlatch maintenance locking mechanism by pulling and holding the handle (item 2), then pull the platform fully to the maintenance position.

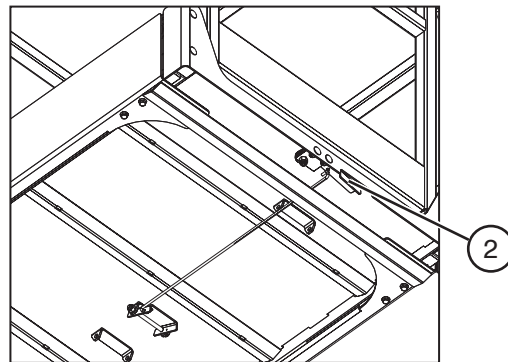

Figure 3-16. Maintenance Lock

6. Open hydraulic/electrical compartment cover and properly install the prop bar (item 3).

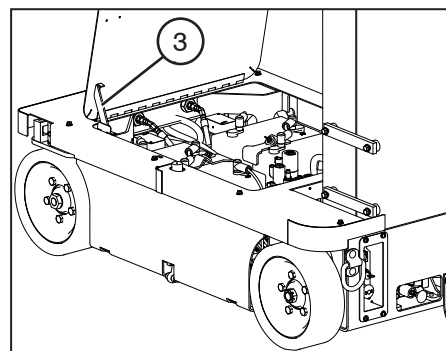

Figure 3-17. Prop Bar

3.12a Battery Maintenance

This section provides the operator with procedures on how to service and charge the battery. This also provides charger operation instructions.

3.12a-1 Battery Service Procedure



WARNING

Explosion Hazard - Keep flames and sparks away. Do not smoke near batteries.



WARNING

Battery acid is extremely corrosive - Wear proper eye and facial protection as well as appropriate protective clothing. If contact occurs, immediately flush with cold water and seek medical attention.

1. Turn main power disconnect switch to “○” off position.
2. Check battery case for damage.
3. Check battery fluid level in each battery. If plates are not covered by at least 1/2” (13 mm) of solution, add distilled or demineralized water.
4. Clean battery terminals and cable ends thoroughly with a terminal cleaning tool or wire brush.
5. Make sure all battery connections are tight.
6. Replace any battery that is damaged or incapable of holding a lasting charge.
7. Do not use any batteries other than flooded lead-acid batteries of the proper Ah rating.



WARNING

Use original or equivalent to the original parts and components for the aerial platform.

3.12a-2 Battery Charging Operation

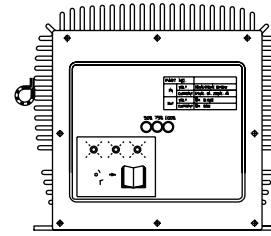

Figure 3-18. Battery Charger



DANGER

Risk of electric shock - Do not immerse the charger in water. Though the charger is highly resistant to water, it is not designed for immersion and an electric shock can occur.

1. Provide adequate ventilation for the batteries and charger. The convection cooled design requires access to cooling air for proper operation. Do not allow blankets or other materials to cover the charger. Although the charger protects itself against overheating, the charger cooling fins should be cleaned if clogged with debris for best performance.



WARNING

There could be a spark during charging. Be careful when using fuels, solvents or other flammables near the charger or batteries.

2. Connect the power supply cord to a properly grounded 100V/50 or 60Hz, 115V/50 or 60Hz, or 230V/50 or 60Hz socket. This charger automatically senses and adjusts to the AC input voltage range.



CAUTION

When changing the input voltage wait until all the LEDs are OFF or wait a minimum of 20 seconds before switching on the new voltage.

- The charging time is affected by numerous factors including battery Amp-Hour capacity, depth of discharge, battery temperature, and battery condition (new, old or defective). Batteries larger than 240 AH can be recharged but will take longer.



WARNING

Do not disconnect the DC output wires near the batteries when the charger is ON. The resulting arcing could cause the batteries to explode. If the charger must be disconnected, first disconnect the AC power supply cord from its outlet, then disconnect the charger DC connections.



WARNING

Risk of an electric shock - Do not touch un-insulated parts of the charger output wires, battery connector, or battery terminals.



WARNING

Visually and manually inspect to verify the DC output wires and terminals are in good working condition before each use.

- The charger will start automatically within four to six seconds. The charger will start even with severely discharged batteries (down to 1V terminal voltage). Once charging starts, the LEDs indicate the charging progress.

Charging State LED

State of charge	1 ST LED	2 ND LED	3 RD LED
0 to 50%	Blinking	Off	Off
50% to 75%	On	Blinking	Off
75% to 100%	On	On	Blinking
100%	On	On	On

60133AA

The charger goes into an equalizing charge mode after the batteries are charged and all 3 LEDs are “ON”. The charger will continue to charge at a low current then shut off automatically when complete. If all 3 LEDs blink together, there is a problem.

Take proper action according to the following instructions:

3 LEDs blink once simultaneously:

Output connection error. Check the battery and charger connection. The output may not be connected to the batteries or the connections to the batteries may have corroded or loosened. The output may be shorted due to improper connection to the batteries or pinched wires. The output may be connected in reverse polarity to the batteries. The charger is not damaged by any of these problems.

3 LEDs blink twice simultaneously:

The charger is indicating that the AC voltage is too low or too high. Check the AC input voltage.

3 LEDs blink three times simultaneously:

Charger is overheated. No action required. When the charger cools, charging will restart automatically. Check and correct for dirt or other debris on charger that may be reducing cooling.

3 LEDs blink four times simultaneously:

Input or output over current. No action required, charger will correct and restart automatically.

100% LED lamp blinks:

Charger 18-hour timer has timed out due to battery problem.

Batteries do not fully charge.

If the batteries are charged overnight, make sure the AC supply is not being switched off at night with other building items. Check battery condition and for dead cells or reduced capacity. Replace charger only if other problems are not found.

The AC line circuit breaker or fuse is blown.

A defective circuit breaker or fuse, an overloaded circuit, or a charger problem can cause this condition. Try connecting the charger to a different AC outlet (on a different circuit) in the building. If the AC supply checks good, the charger should be replaced.

3.12b Battery Maintenance (If Equipped)

This section provides the operator with procedures on how to service and charge the battery. This also provides the charger operation instructions.

3.12b-1 Servicing the battery

⚠ WARNING



Explosion hazard. Keep flames and sparks away. Do not smoke near batteries. Battery acid releases explosive gas while charging. Charge batteries in a well-ventilated area.

⚠ WARNING

Battery acid is extremely corrosive – wear proper eye and facial protection as well as appropriate protective clothing. If contact occurs, immediately flush with cold water and seek medical attention.

1. Turn the main power disconnect switch to the off position.
2. Check the battery case for damage.
3. Check the battery fluid level in each battery. If the plates are not covered by at least 13 mm (1/2 in) of solution, add distilled or demineralized water.
4. Make sure all the battery connections are tight.

NOTE

Do not use any batteries other than the flooded lead-acid batteries of the proper Ah rating.

⚠ WARNING

Use the original or equivalent to the original parts and components for the MEWP.

3.12b-2 Charging the battery

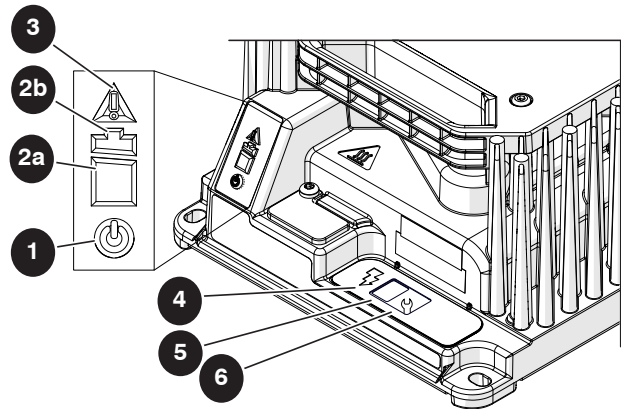

Figure 3-19. Battery Charger

No.	Indicator type	State	Description/action required
1	AC power	Blue	Battery charger is connected to the AC power.
2a	Battery charging <80%	Flashing green	Low charge— continue charging.
		Solid green	High charge— continue charging.
2b	Battery charging >80%	Flashing green	High charge— can discontinue charging.
		Solid green	Charge complete— discontinue charging.
3	Fault/error	Solid red	Charger fault—refer to the service manual.
		Flashing amber	Error encountered—refer to the service manual.
4	Charging output	Solid yellow	Charger output is active.
5	Charge profile/error display	Current algorithm or fault/error code	N/A.
6	Select charge profile	Current charging algorithm	N/A.

⚠ WARNING

Risk of electric shock – do not immerse the charger in water. Though the charger is highly resistant to water, it is not designed for immersion, and an electric shock can occur.

⚠ CAUTION

Hot Surfaces - During charging, the surface of the charger may become hot to the touch, especially in higher ambient temperatures. This is normal. Avoid touching the surface of the charger.

1. Provide adequate ventilation for the batteries and charger.

NOTE

The convection cooled design requires access to cooling air for proper operation. Do not allow blankets or other materials to cover the charger. Although the charger protects itself against overheating, the charger cooling fins should be cleaned if clogged with debris for best performance.

⚠ WARNING

There could be a spark during charging. Be careful when using fuels, solvents or other flammables near the charger or batteries.

2. Connect the power supply cord to a properly grounded socket between 100 to 240 VAC, 50/60 Hz. The charger automatically senses and adjusts to the AC input voltage range.
3. The charging time is affected by numerous factors including the battery Amp-Hour capacity, depth of discharge, battery temperature, and battery condition (new, old, or defective). Batteries larger than 240 AH can be recharged but will take longer.

⚠ WARNING

Do not disconnect the DC output wires near the batteries when the charger is ON. The resulting arcing could cause the batteries to explode. If the charger must be disconnected, first disconnect the AC power supply cord from its outlet, then disconnect the charger DC connections.

⚠ WARNING

Risk of an electric shock – do not touch uninsulated parts of the charger output wires, battery connector, or battery terminals.

⚠ WARNING

Visually and manually inspect to verify the DC output wires and terminals are in good working condition before each use.





4. The charger will start automatically within four to six seconds. The charger will start even with severely discharged batteries (down to 1 V terminal voltage). Once the charging starts, the LEDs indicate the charging progress.
 - **Batteries do not fully charge:** If the batteries are charged overnight, make sure the AC supply is not being switched off at night with other building items. Check the battery condition and for dead cells or reduced capacity. Replace the charger only if other problems are not found.
 - **The AC line circuit breaker or fuse is blown:** A defective circuit breaker or fuse, an overloaded circuit, or a charger problem can cause this condition. Try connecting the charger to a different AC outlet (on a different circuit) in the building. If the AC supply is sufficient, the charger should be replaced.

Table 4.1 Standard and Optional Features

Models	SJ12	SJ16
STANDARD EQUIPMENT		
Maximum drive height	Full Height	Full Height
Variable speed, front two wheel hydraulic drive	*	*
Zero inside turn radius	*	*
Dual holding brakes	*	*
Proportional controls	*	*
24V DC power source	*	*
Low voltage battery protection	*	*
Solid rubber, non-marking tires	*	*
Pothole protection system	*	*
110V AC outlet at platform with GFI	*	*
Tilt alarm with drive & lift cut-out	*	*
All motion audible alarm	*	*
Fall Protection Anchorage(s)	*	*
Operator horn	*	*
Lift lugs/tie downs	*	*
Relay based control system	*	*
Color coded and numbered wiring system	*	*
Platform traversing	*	*
Chain entrance	*	*
White nonmarking tires	*	*
OPTIONAL EQUIPMENT		
Flashing light	*	*
AC inverter	*	*
Full height spring hinged gate	*	*
Saloon spring hinged gate	*	*
Half height spring hinged gate	*	*
Bio oil	*	*
Grey nonmarking tires	*	*
Lowering only alarm	*	*
ATTACHMENTS		
Light duty pipe rack/steel stud rack	*	*
Tool tray	*	*
Fluorescent tube carrier	*	*

265AC_ANSI

Table 4.2 Owner's Annual Inspection Record

										
 Model Number: _____ Serial Number: _____										
*		20__	20__	20__	20__	20__	20__	20__	20__	20__
**										

1000AB

This decal is located on the mast below the hourmeter. It must be completed after an annual inspection has been completed. Do not use the aerial platform if an inspection has not been recorded in the last 13 months.



	Pictorial	Description
*		Inspection Date
**		Inspector Signature

Table 4.3 Specifications and Features

MODEL	SJ12	SJ16
Weight *	1720 lb. (780 kg)	2130 lb. (966 kg)
Overall Width	30.5 in. (77.5 cm)	30.5 in. (77.5 cm)
Overall Length	55.0 in. (140 cm)	55.0 in. (140 cm)
Platform Size (Inside)	27.0 in. x 36.8 in. (68.5 cm x 93.5 cm)	27.0 in. x 36.8 in. (68.5 cm x 93.5 cm)
Platform Traversing	20 in. (50.8 cm)	20 in. (50.8 cm)
Height		
Working Height	18 ft. (5.49 m)	21.6 ft. (6.55 m)
Platform Elevated Height	12 ft. (3.66 m)	15.6 ft. (4.75 m)
Stowed Height	70.3 in. (178.6 cm)	70.3 in. (178.6 cm)
Drive Height	Full	Full
Lowered Platform Height	18 in. (45.72 cm)	18 in. (45.72 cm)
Standard Operating Times		
Lift Time (Rated Load)	13 - 16 s	16 - 25 s
Lower Time (Rated Load)	13 - 17 s	17 - 19 s
Chassis		
Normal Drive Speed	2.0 mph (3.1 km/h) - 2.5 mph (4.0 km/h)	2.0 mph (3.1 km/h) - 2.5 mph (4.0 km/h)
Elevated Drive Speed	0.4 mph (0.6 km/h) - 0.5 mph (0.8 km/h)	0.4 mph (0.6 km/h) - 0.5 mph (0.8 km/h)
Gradeability (Ramp Angle [Reverse/Forward])**	30% / 25%	30% / 25%
Tires (Solid Rubber)	12 x 4 in. (309 x 100 mm)	12 x 4 in. (309 x 100 mm)
Hydraulic Oil		
Type	ATF Dexron III	ATF Dexron III
Tank Capacity	1.3 gal. (4.92 l)	1.3 gal. (4.92 l)

280AB_ANSI

* Weights are approximate; refer to serial nameplate for specific weight.

** Refer to [Section 3.9 Loading/Unloading](#) for more details.

Table 4.4 Maximum Platform Capacities (Evenly Distributed)

MODEL	Capacity		Maximum Wind Speed	Tilt Cutout Setting
	Weight	Person(s)		
SJ12	500 lb.	2 Person(s)	28 mph	1.5 degrees x 3 degrees
SJ16	500 lb.	2 Person(s)	28 mph	1.5 degrees x 3 degrees

281AA_ANSI

Table 4.5 Floor Loading Pressure

MODEL		Total Aerial Platform Weight	Total Aerial Platform Load	
			Wheel	OUP**
		lb.	lb.	psf
SJ12	min*	1720	560	147
	max*	2220	888	197
SJ16	min*	2130	640	188
	max*	2630	1052	234

282AB_ANSI

- * **min** - Aerial platform weight with no options
- * **max** - Aerial platform weight + all options + full capacity
- ** **LCP - Locally Concentrated Pressure** is a measure of how hard the aerial platform presses on the areas in direct contact with the floor. The floor covering (tile, carpet, etc.) must be able to withstand more than the indicated values above.
- OUP - Overall Uniform Pressure** is a measure of the average load the aerial platform imparts on the whole surface directly underneath it. The structure of the operating surface (beams, etc.) must be able to withstand more than the indicated values above.

NOTE:

The LCP or OUP that an individual surface can withstand varies from structure to structure and is generally determined by the engineer or architect for that particular structure (see Floor Loading Pressure chart below).

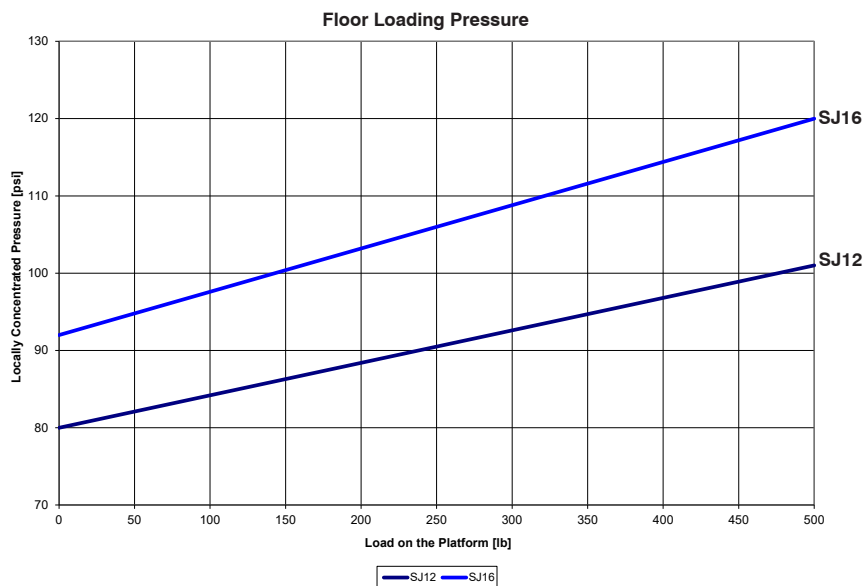

Floor Loading Pressure

Locally Concentrated Pressure (LCP):

Foot Print Area identified by test.

$$LCP = \frac{\text{Wheel Load}}{\text{Foot Print Area}}$$

Overall Uniform Pressure (OUP):

Base Area = Length x Width

$$OUP = \frac{\text{Weight of Aerial Platform} + \text{Capacity}}{\text{Base Area}}$$

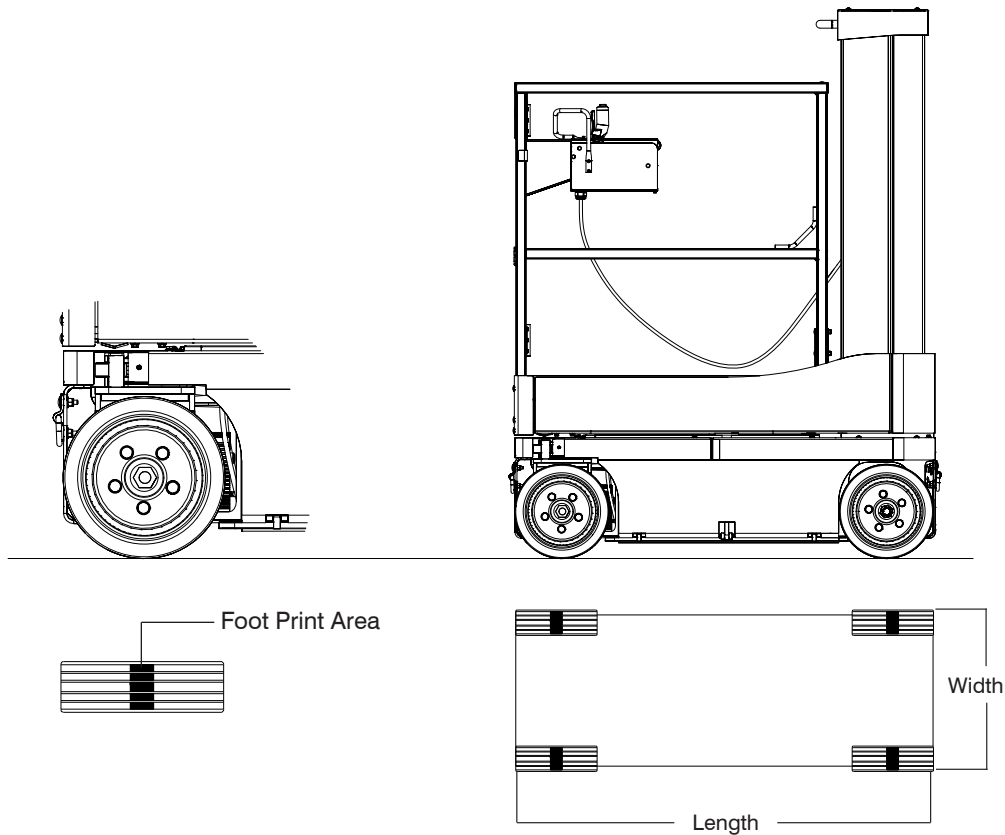

! WARNING

Intermixing tires of different types or using tires of types other than those originally supplied with this equipment can adversely affect stability. Therefore, replace tires only with the exact Skyjack-approved type. Failure to operate with matched approved tires in good condition may result in death or serious injury.

General Maintenance

Before attempting any repair work, disconnect the battery by turning the main power disconnect switch to “○” off position. Preventive maintenance is the easiest and least expensive type of maintenance.

Table 4.6 Maintenance and Inspection Schedule

Frequency	Daily	3 months or 150 hours	Yearly	Frequency	Daily	3 months or 150 hours	Yearly
Visual and Daily Maintenance Inspections				Function Tests			
Labels	A			Test Main Power Disconnect Switch	A		
Electrical	A			Base Control Console	A		
Limit Switches	A			Test Base Emergency Stop Light	A		
Hydraulic	A			Test Base Emergency Stop	A		
Base	A			Test Off/Platform/Base Switch	A		
Main Power Disconnect Switch	A			Test Lower/Neutral/Raise Switch	A		
Base Control Switches	A			Test Emergency Lowering	A		
110V/220V Outlet Receptacle (If equipped)	A			Test Platform Maintenance Limit Switch	A		
Battery Charger	A			Platform Control Console	A		
Pothole Protection Device	A			Test Platform Emergency Stop	A		
Wheel/Tire Assembly	A			Test Enable Trigger Switch	A		
Platform Assembly	A			Test Lift/Off/Drive Switch Off Position	A		
Fall Protection Anchorage(s)	A			Test Steering	A		
AC Outlet	A			Test Driving	A		
Platform Control Console	A			Test Brakes	A		
Manuals	A			Test Horn	A		
Hydraulic/Electrical Compartment	A			Test Platform Raising/Lowering	A		
Battery	A			Test Elevated Drive Speed	A		
Main Manifolds	A			Test Pothole Sensor	A		
Hydraulic Tank	A			Optional Equipment/Attachments	A		
Hydraulic Pump and Motor	A			Test Flashing Lights (If equipped)	A		
Hydraulic Oil	A						
Steer Cylinder Assembly	A						
Motor Controller	A						
Tilt Sensors	A						
Limit Switches	A						
Lifting Mechanism	A						
Mast Assembly	A						
Wear Pads	A						
Chains	A						
Optional Equipment/Attachments	A						
Flashing Lights (If equipped)	A						
Pipe Rack (If equipped)	A						

B*†

B*†

259AD_ANSI

- A - Perform Visual and Daily Maintenance Inspections & Functions Test. Refer to Section 2.3 and Section 2.4 of this manual.
- B - Perform Scheduled Maintenance Inspection. Refer to Service & Maintenance manual.
- * - Maintenance must be performed only by trained and competent personnel who are familiar with mechanical procedures.
- † - Refer to Skyjack's website @ www.skyjack.com for latest service bulletins prior to performing quarterly or yearly inspection.



WARNING

Use original or equivalent to the original parts and components for the aerial platform.

Table 4.7 Operator’s Checklist



Serial Number: _____
 Model: _____
 Hourmeter Reading: _____
 Date: _____
 Time: _____

Operator's Name (Printed): _____
 Operator's Signature: _____

Each item shall be inspected using the appropriate section of the Skyjack operating manual. As each item is inspected, check the appropriate box.

- P** - PASS
- F** - FAIL
- R** - REPAIRED
- NA** - NOT APPLICABLE

INSPECTION FREQUENCY

- FREQUENTLY
- DAILY
- ANNUALLY
- BI-ANNUALLY

	N/A	P	F	R
Visual and Daily Maintenance Inspections				
Labels				
Electrical				
Limit Switches				
Hydraulic				
Base				
Main Power Disconnect Switch				
Base Control Switches				
110V/220V Outlet Receptacle (If equipped)				
Battery Charger				
Pothole Protection Device				
Wheel/Tire Assembly				
Platform Assembly				
Fall Protection Anchorage(s)				
AC Outlet				
Platform Control Console				
Manuals				
Hydraulic/Electrical Compartment				
Battery				
Main Manifolds				
Hydraulic Tank				
Hydraulic Pump and Motor				
Hydraulic Oil				
Steer Cylinder Assembly				
Motor Controller				
Tilt Sensors				
Limit Switches				
Lifting Mechanism				
Mast Assembly				
Wear Pads				
Chains				
Optional Equipment/Attachments				
Flashing Lights (If equipped)				
Pipe Rack (If equipped)				

	N/A	P	F	R
Function Tests				
Test Main Power Disconnect Switch				
Base Control Console				
Test Base Emergency Stop Light				
Test Base Emergency Stop				
Test Off/Platform/Base Switch				
Test Lower/Neutral/Raise Switch				
Test Emergency Lowering				
Test Platform Maintenance Limit Switch				
Platform Control Console				
Test Platform Emergency Stop				
Test Enable Trigger Switch				
Test Lift/Off/Drive Switch Off Position				
Test Steering				
Test Driving				
Test Brakes				
Test Horn				
Test Platform Raising/Lowering				
Test Elevated Drive Speed				
Test Pothole Sensor				
Optional Equipment/Attachments				
Test Flashing Lights (If equipped)				

260AE_ANSI

Note:
 Make a copy of this page or visit the Skyjack web site:
www.skyjack.com for a printable copy.

Label Legend



A red horizontal bar at the top of a white rounded rectangle contains a warning triangle icon and a book icon. Below the bar, the text reads "Safety Red indicates DANGER." An arrow points from the text "Safety Red" to the red bar.



An orange horizontal bar at the top of a white rounded rectangle contains a warning triangle icon and a book icon. Below the bar, the text reads "Safety Orange indicates WARNING." An arrow points from the text "Safety Orange" to the orange bar.

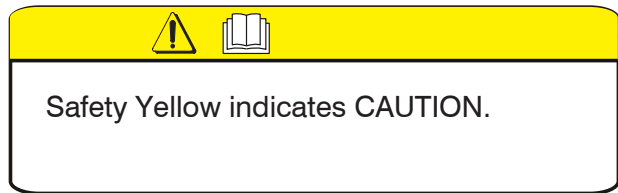

A yellow horizontal bar at the top of a white rounded rectangle contains a warning triangle icon and a book icon. Below the bar, the text reads "Safety Yellow indicates CAUTION." An arrow points from the text "Safety Yellow" to the yellow bar.

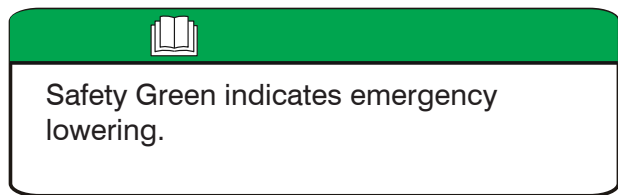



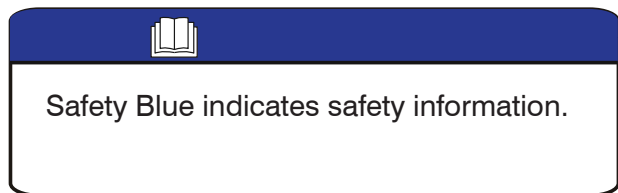



A green horizontal bar at the top of a white rounded rectangle contains a book icon. Below the bar, the text reads "Safety Green indicates emergency lowering." An arrow points from the text "Safety Green" to the green bar.

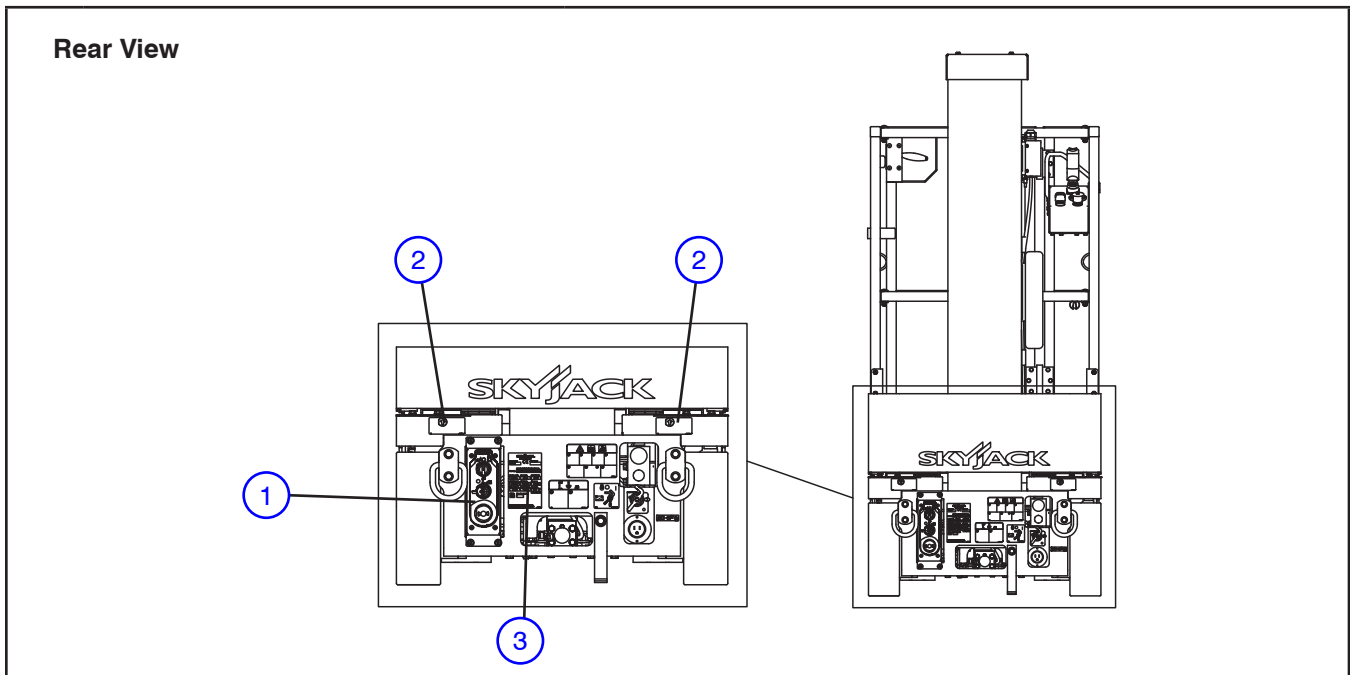

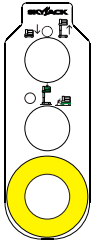
A blue horizontal bar at the top of a white rounded rectangle contains a book icon. Below the bar, the text reads "Safety Blue indicates safety information." An arrow points from the text "Safety Blue" to the blue bar.

Labels - Models SJ12 & SJ16

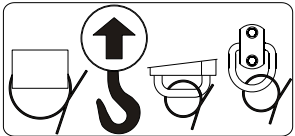
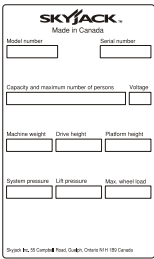

Nº	Label Pictorial	Description
1		<p>Base Controls</p> <p>Select “” to lower or “” raise platform.</p> <p>Select “” platform to enable platform controls, “” off to disable controls or “” base to enable base control console.</p> <p>Push “” to disable controls.</p>
2		<p>Lift and Tie Down Points</p> <p>Only use these points for lifting or tying down.</p>
3		<p>Serial Plate*</p> <p>Product identification and specifications. *Serial plates will vary, may not be as shown.</p>

Labels - Models SJ12 & SJ16

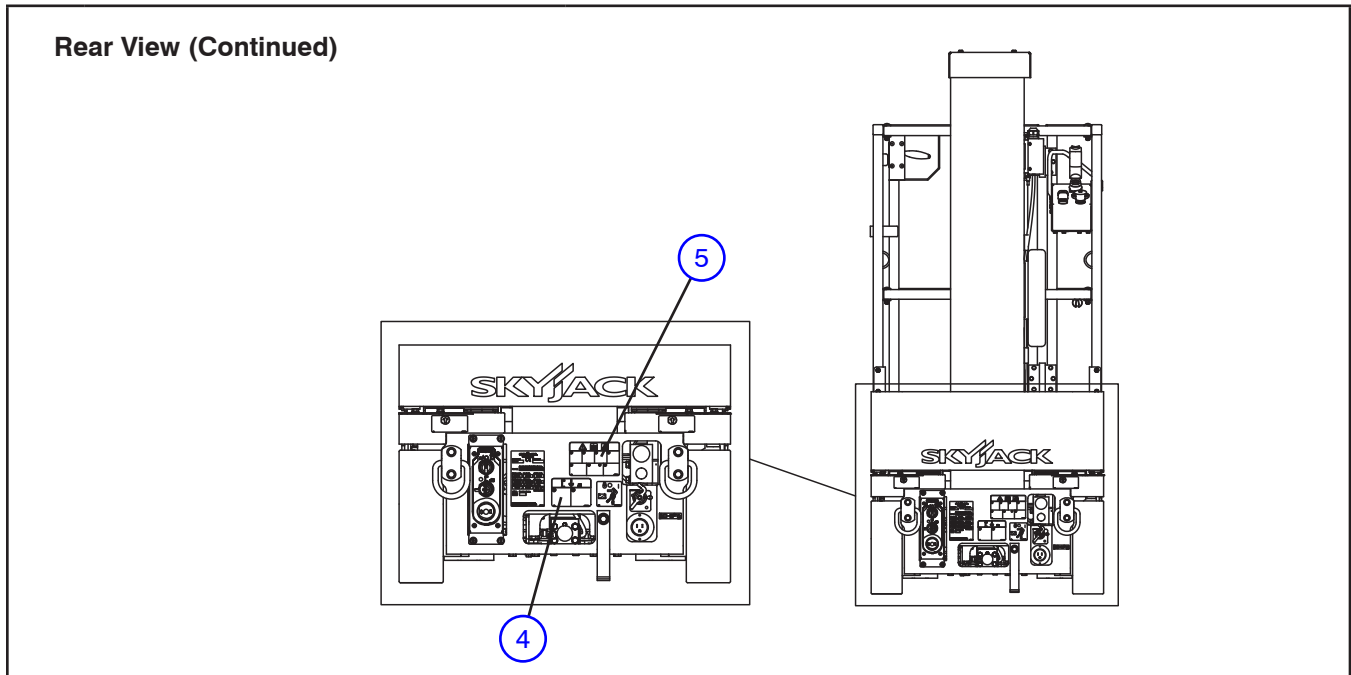

Nº	Label Pictorial	Description
4		<p>Emergency Lowering Procedure Refer to Operating manual.</p> <ol style="list-style-type: none"> 1. Turn main power disconnect switch to off position. 2. Pull emergency lowering valve to lower the platform.
5		<p>Winching/Towing/Pushing Procedure Refer to Operating manual.</p> <ol style="list-style-type: none"> 1. Block or chock wheels to prevent aerial platform from rolling. 2. Turn main power disconnect switch to off position. 3. Locate brake valve and pump. 4. Push in black knob. Pump by pushing red knob in and out until firm resistance is felt. Brake is now released. 5. Push/tow/winch to desired location. 6. Block or chock wheels to prevent aerial platform from rolling. 7. Reset brake by pulling out black knob.

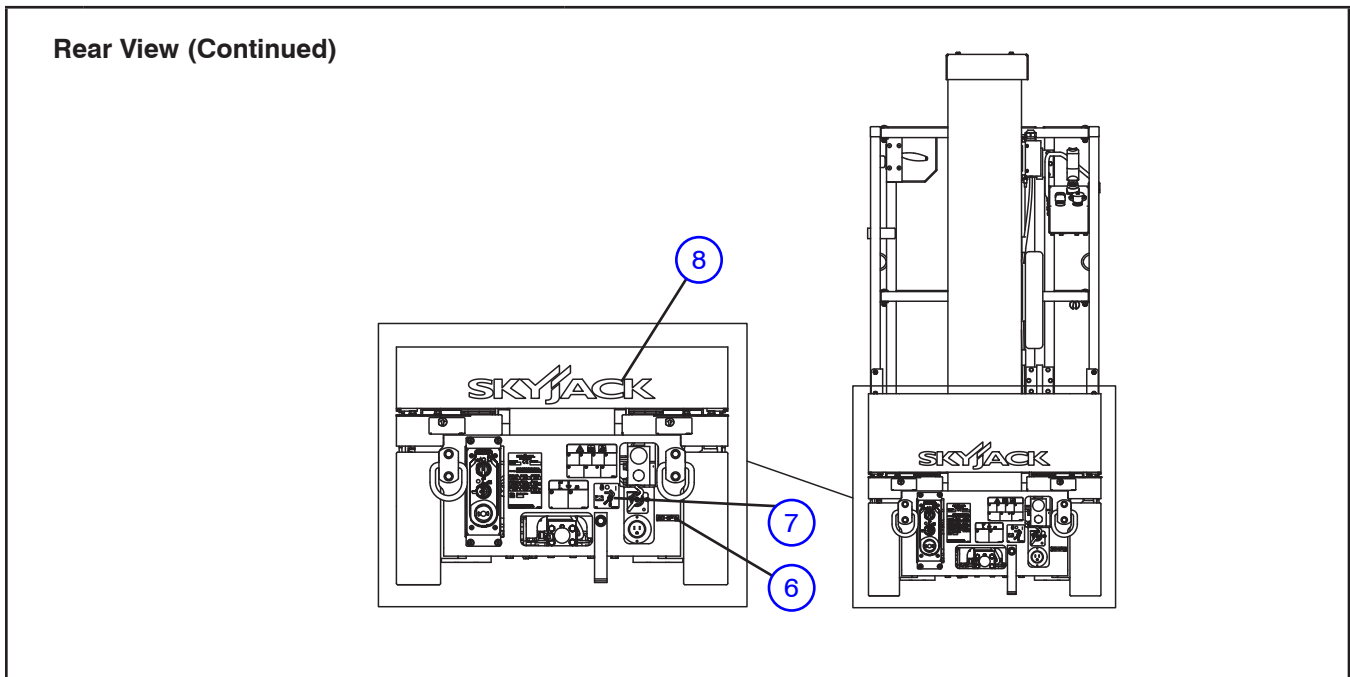

Labels - Models SJ12 & SJ16



Nº	Label Pictorial	Description
6		<p>Connect Platform AC Supply</p> <p>Connect AC power supply here for platform accessory outlet.</p>
7		<p>Main Power Disconnect</p> <p>Rotate clockwise to turn on main power; rotate counterclockwise to turn off main power; insert padlock to lock in position.</p>
8		<p>Skyjack Logo</p> <p>Skyjack.</p>

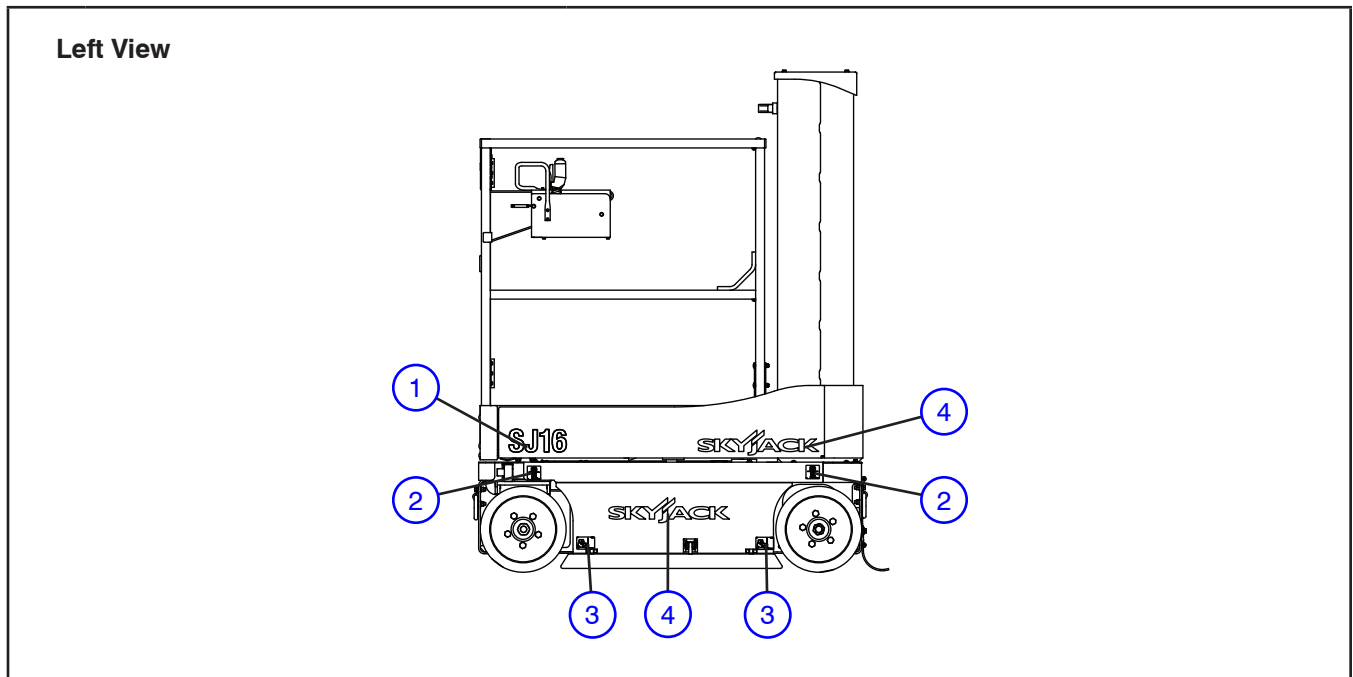

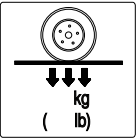
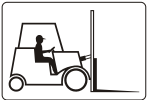

Labels - Models SJ12 & SJ16

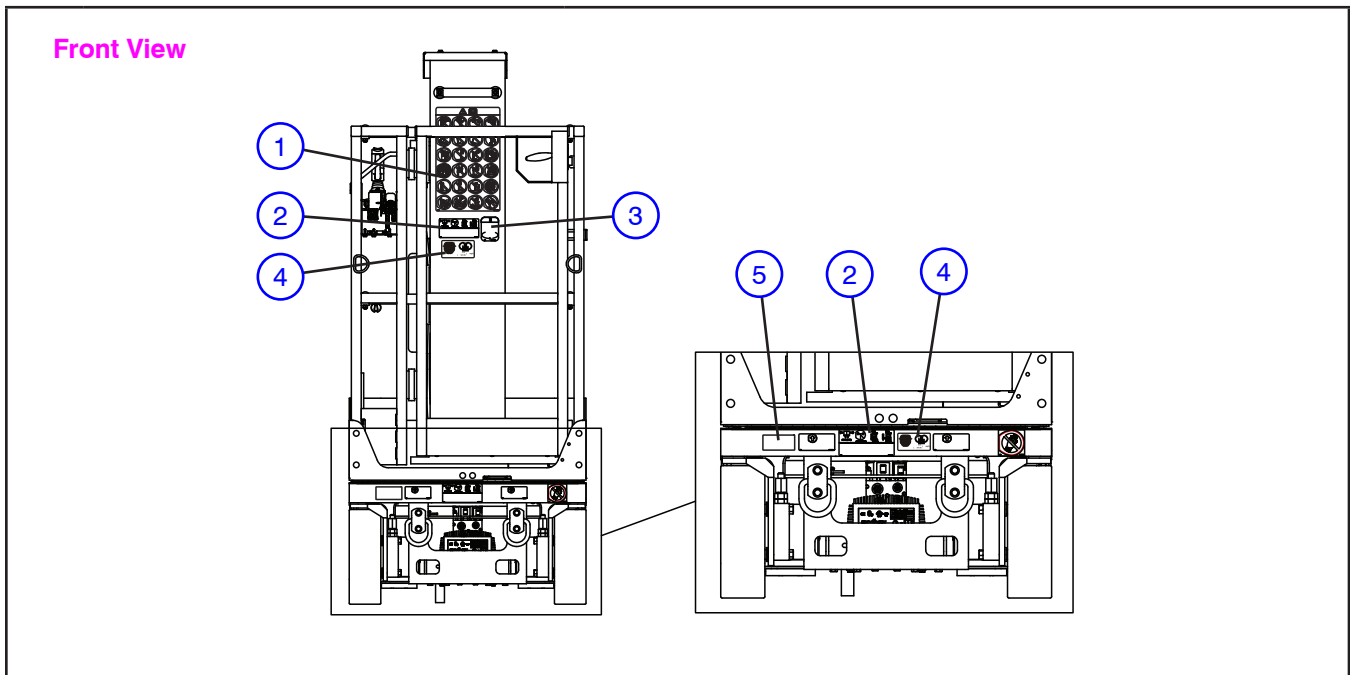

Nº	Label Pictorial	Description
1		<p>Model Number*</p> <p>Product Identifier *Model number will vary, may not be as shown.</p>
2		<p>Wheel Load</p> <p>Indicates rated wheel load.</p>
3		<p>Forklift Lifting Location</p> <p>Insert fork fully into forklift lifting location to lift aerial platform.</p>
4		<p>Skyjack Logo</p> <p>Skyjack.</p>

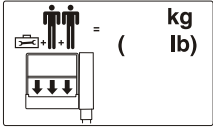

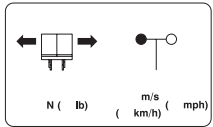

Labels - Models SJ12 & SJ16

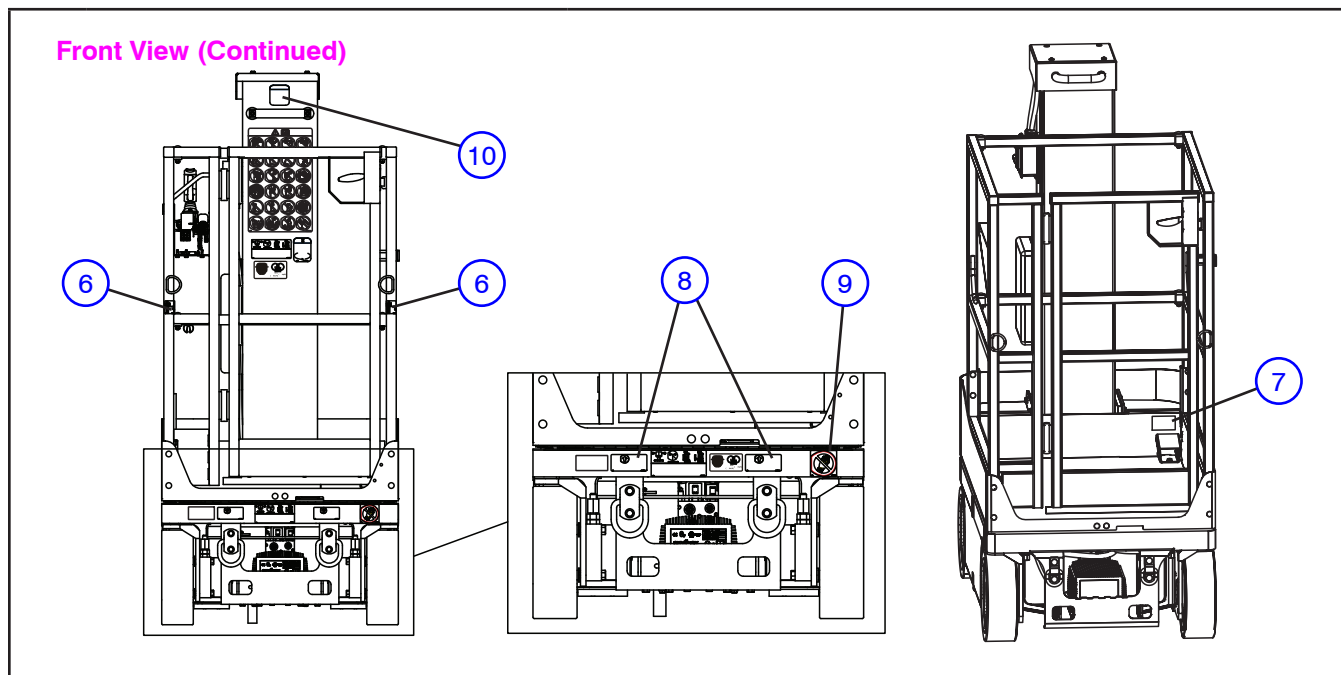

Nº	Label Pictorial	Description
1		<p>Hazard Identification</p> <p>Refer to Section 1: Safety Rules. Read and understand the outlined risks associated with this work platform prior to operation.</p>
2		<p>Horizontal Load Rating & Platform Capacity*</p> <p>Operating with rated work load in each configuration below indicated wind speed only. *Label will vary, may not be as shown.</p>
3		<p>Operator's Daily Inspection.</p> <p>Refer to the Operating manual. Perform visual inspection and function tests at the beginning of each shift. Refer to Section 4: Maintenance and Inspection Schedule.</p>
4		<p>Horizontal Load Rating*</p> <p>Apply no more than the indicated side load. Operate below indicated wind speed only. *Rating will change over varying units.</p>
5		<p>Warning - California Proposition 65</p> <p>Cancer and Reproductive Harm- https://www.p65warnings.ca.gov/.</p>

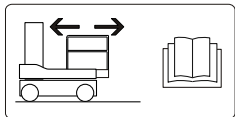
Labels - Models SJ12 & SJ16

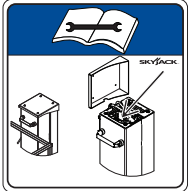

Nº	Label Pictorial	Description
6		<p>Fall Protection Anchorage</p> <p>Rated for one (1) person per anchorage.</p>
7		<p>Platform Traversing Procedure</p> <p>Follow this procedure to reposition platform. Read “” operating manual.</p>
8		<p>Lift and Tie Down Points</p> <p>Only use these points for lifting or tying down.</p>
9		<p>No Jewelry</p> <p>Caution - Do not wear jewelry.</p>
10		<p>Refer to Service Manual.</p> <p>Remove cover to perform scheduled maintenance.</p>

Labels - Models SJ12 & SJ16

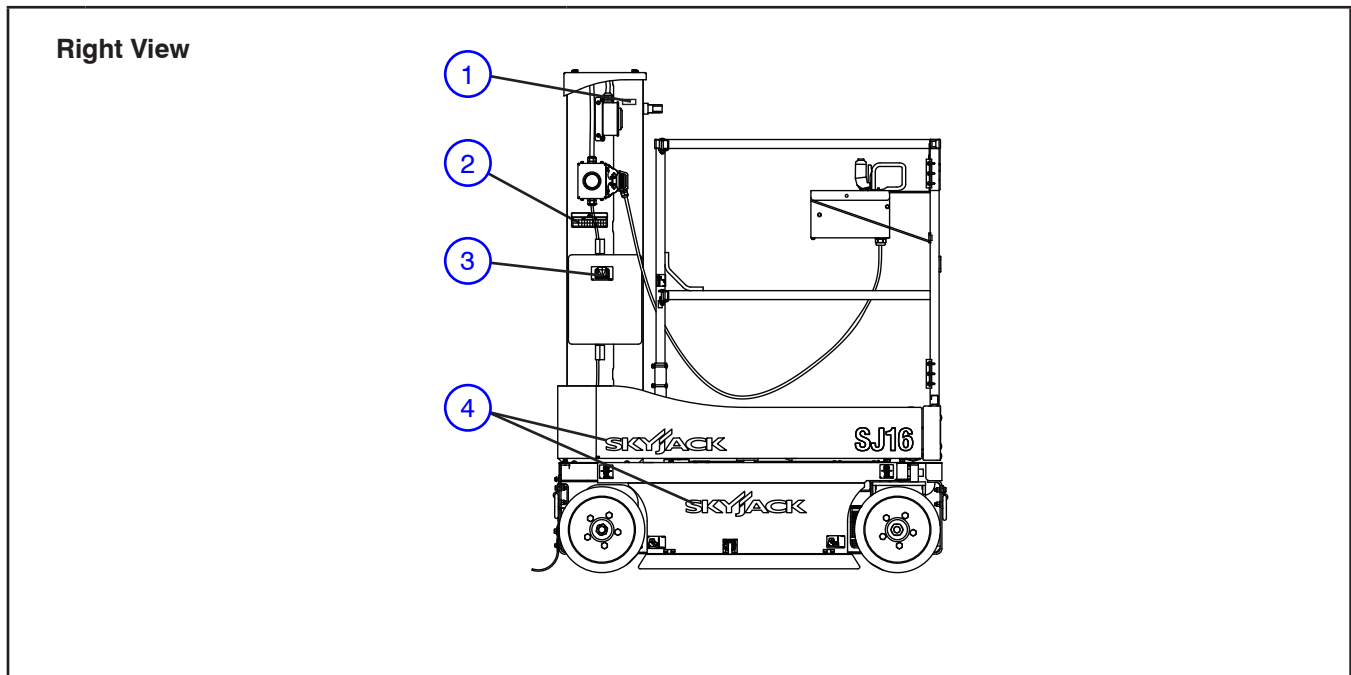

Nº	Label Pictorial	Description
1		<p>Connect Platform AC Supply</p> <p>Connect AC power supply here for platform accessory outlet.</p>
2		<p>Annual Inspection</p> <p>Ensure that work platform has received annual inspection prior to operation.</p>
3		<p>Manual Storage Box</p> <p>Indicates location of operating manual.</p>
4		<p>Skyjack Logo</p> <p>Skyjack.</p>

Labels - Models SJ12 & SJ16

Right View (Continued)

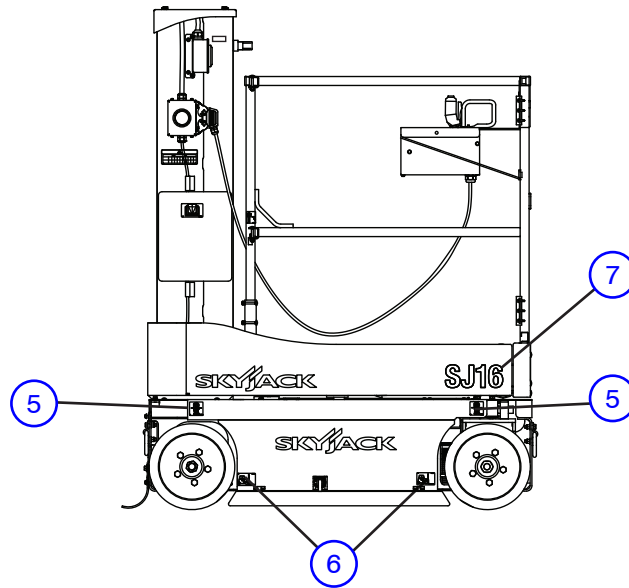

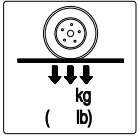
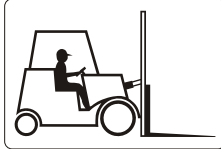
Nº	Label Pictorial	Description
5		<p>Wheel Load</p> <p>Indicates rated wheel load.</p>
6		<p>Forklift Lifting Location</p> <p>Insert fork fully into forklift lifting location to lift aerial platform.</p>
7	<p style="font-size: 2em; font-weight: bold;">SJ16</p>	<p>Model Number*</p> <p>Product Identifier *Model number will vary, may not be as shown.</p>

Labels - Models SJ12 & SJ16

Platform Control Console

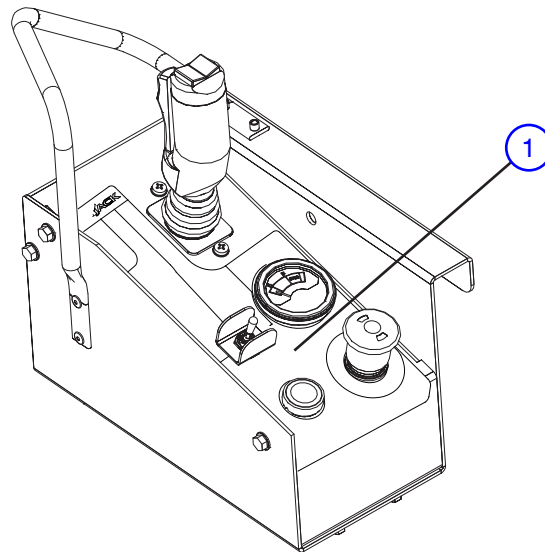

Nº	Label Pictorial	Description
1		<p>Platform Control Console</p> <p>Read “” operating manual.</p> <p>Squeeze “” trigger to enable controller.</p> <p>Operate “” rocker switch to steer.</p> <p>Move controller handle forward to “” raise or backward to “” lower platform.</p> <p>Move controller handle “” forward to drive forward or “” backward to drive reverse.</p> <p>Select “” lift, “” off or “” drive mode.</p> <p>Select “” to sound horn.</p> <p>Push “” to disable controls. The operation light illuminates to indicate upper control availability.</p>



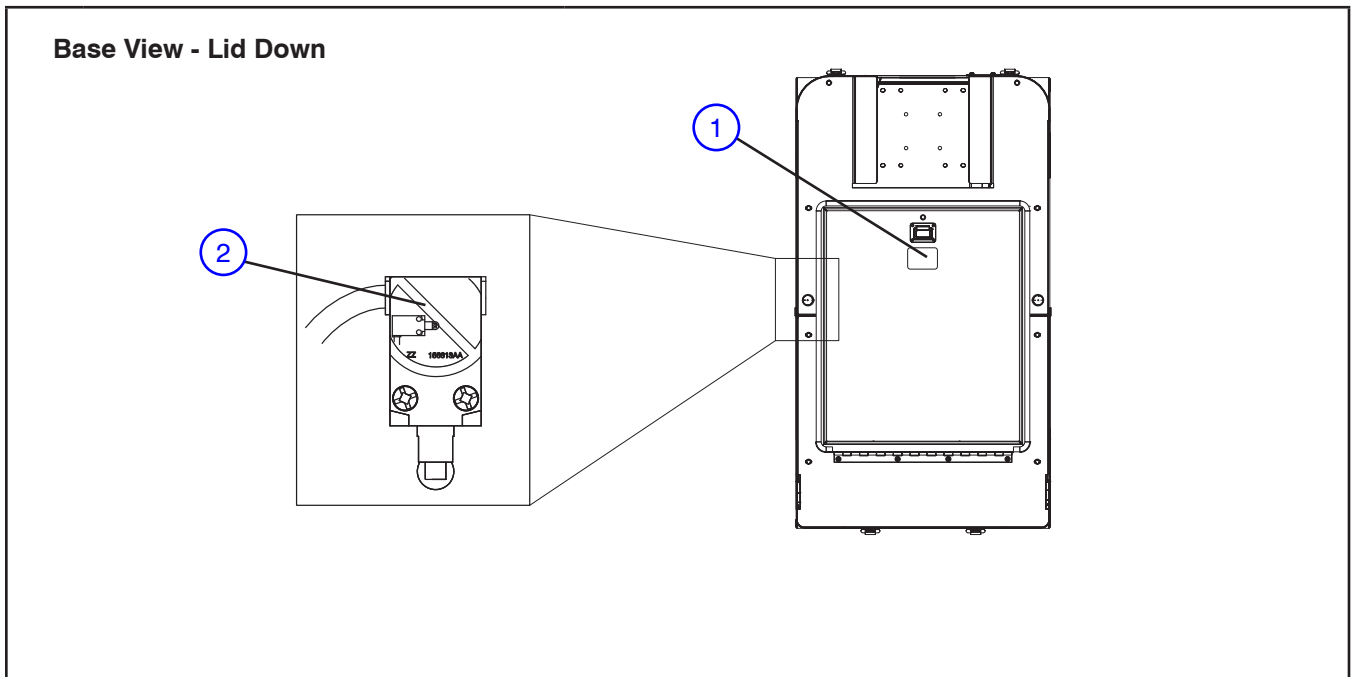

Labels - Models SJ12 & SJ16

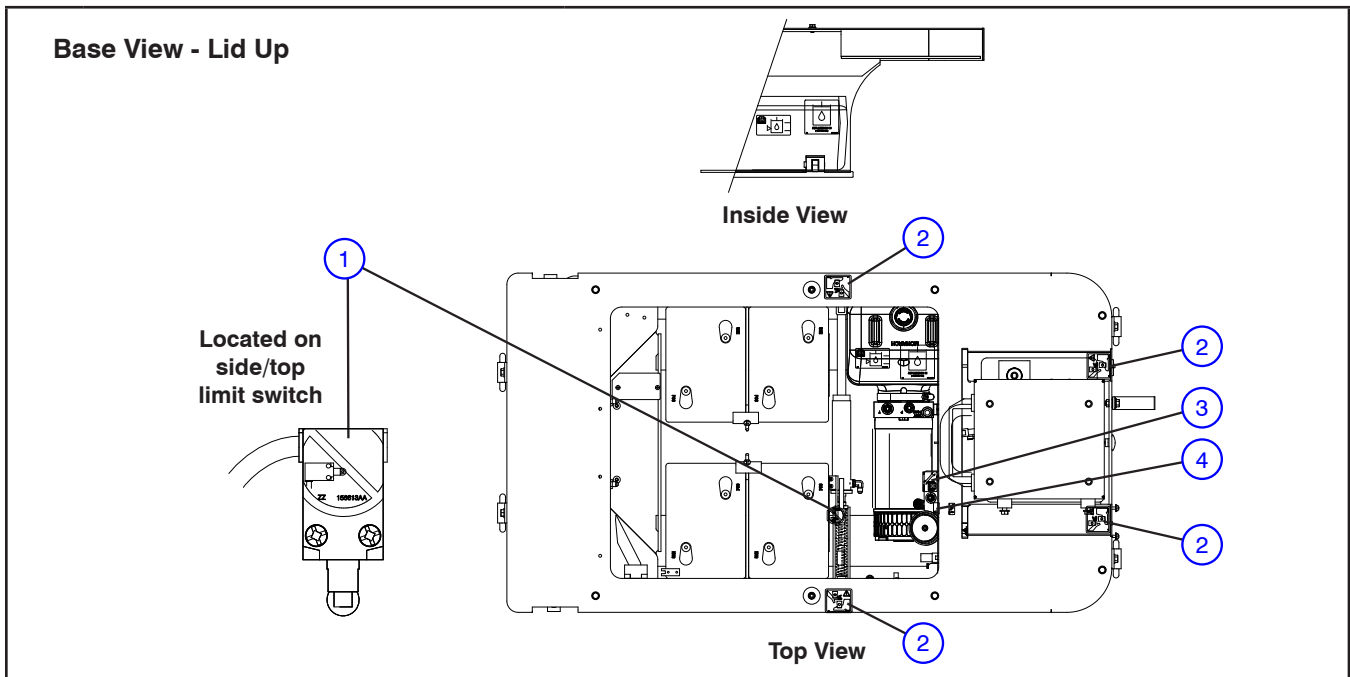

Nº	Label Pictorial	Description
1		<p>Warning - Do Not Open</p> <p>Do not access hydraulic/electrical compartment while platform is elevated.</p>
2		<p>Warning - Do Not Alter</p> <p>Do not alter or disable limit switches or other safety devices.</p>

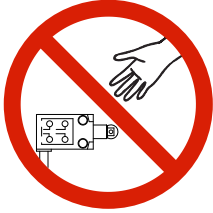

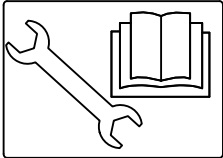
Labels - Models SJ12 & SJ16

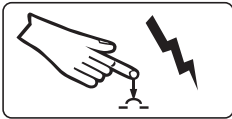

Nº	Label Pictorial	Description
1		<p>Warning - Do Not Alter</p> <p>Do not alter or disable limit switches or other safety devices.</p>
2		<p>Crushing Hazard</p> <p>Danger - Crushing hazard.</p>
3		<p>Diagnostic Switch</p> <p>Enables hydraulic functions for maintenance service.</p> <p>Read “” operating manual.</p>
4		<p>Power Circuit Breaker</p> <p>Push to reset power circuit breaker.</p>

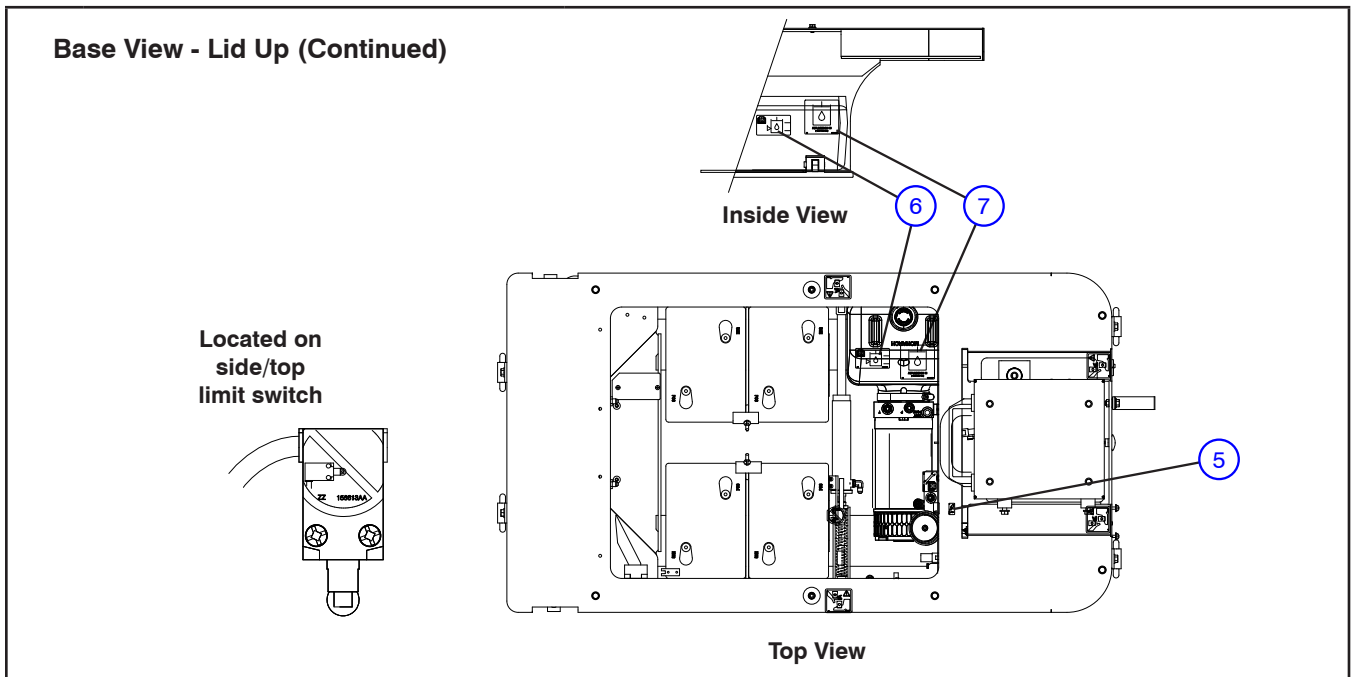
Labels - Models SJ12 & SJ16

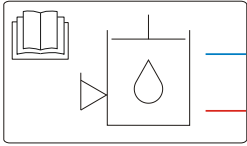

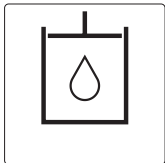
Nº	Label Pictorial	Description
5		<p>Ground Circuit Breaker</p> <p>Push to reset power circuit breaker.</p>
6		<p>Hydraulic Oil Level Indicator</p> <p>Read “” operating manual. Ensure hydraulic oil level is within the minimum (red line) and maximum (blue line) range.</p>
7		<p>Hydraulic Oil ATF Dexron III</p> <p>Replace hydraulic fluid with ATF Dexron III only.</p>

Labels - Models SJ12 & SJ16 - Options and Attachments

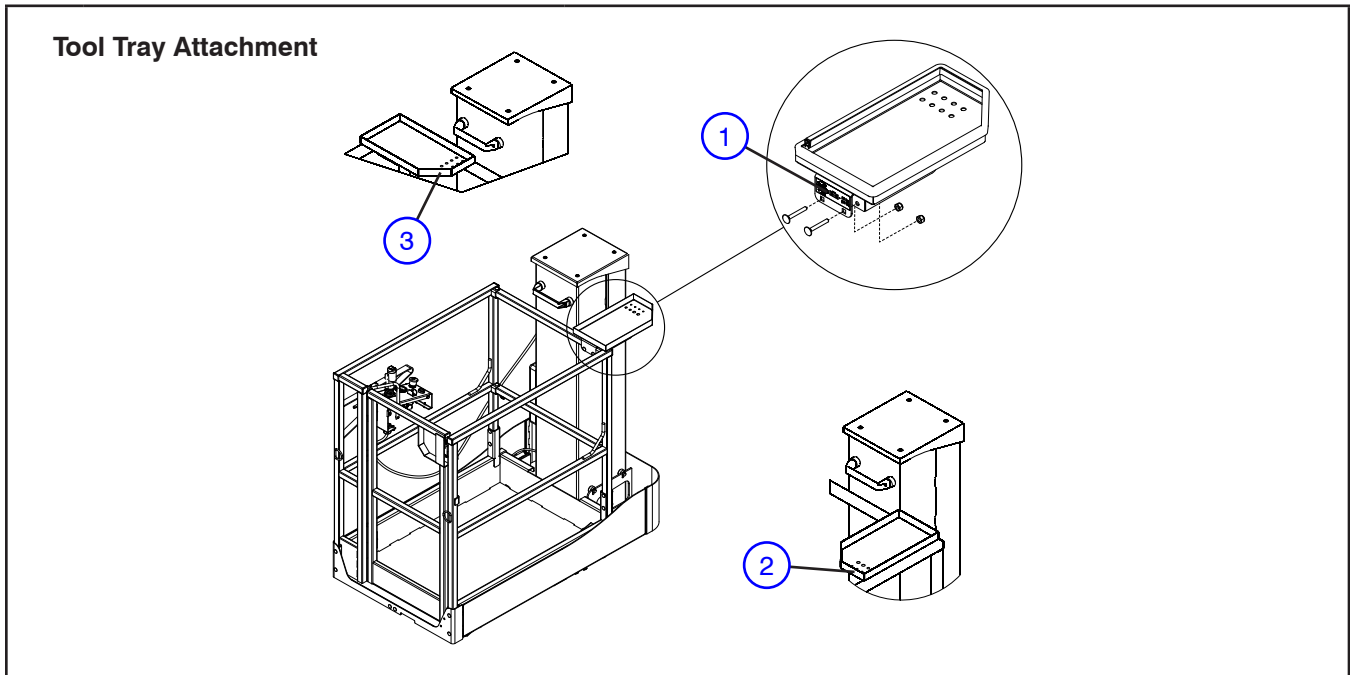

Nº	Label Pictorial	Description
1		<p>Tool Tray Location & Capacity</p> <p>Indicates tool tray location and capacity.</p>
2		<p>Tool Tray Location (1) & Capacity</p> <p>Indicates tool tray location (1) and capacity.</p>
3		<p>Tool Tray Location (2) & Capacity</p> <p>Indicates tool tray location (2) and capacity.</p>

Labels - Models SJ12 & SJ16 - Options and Attachments

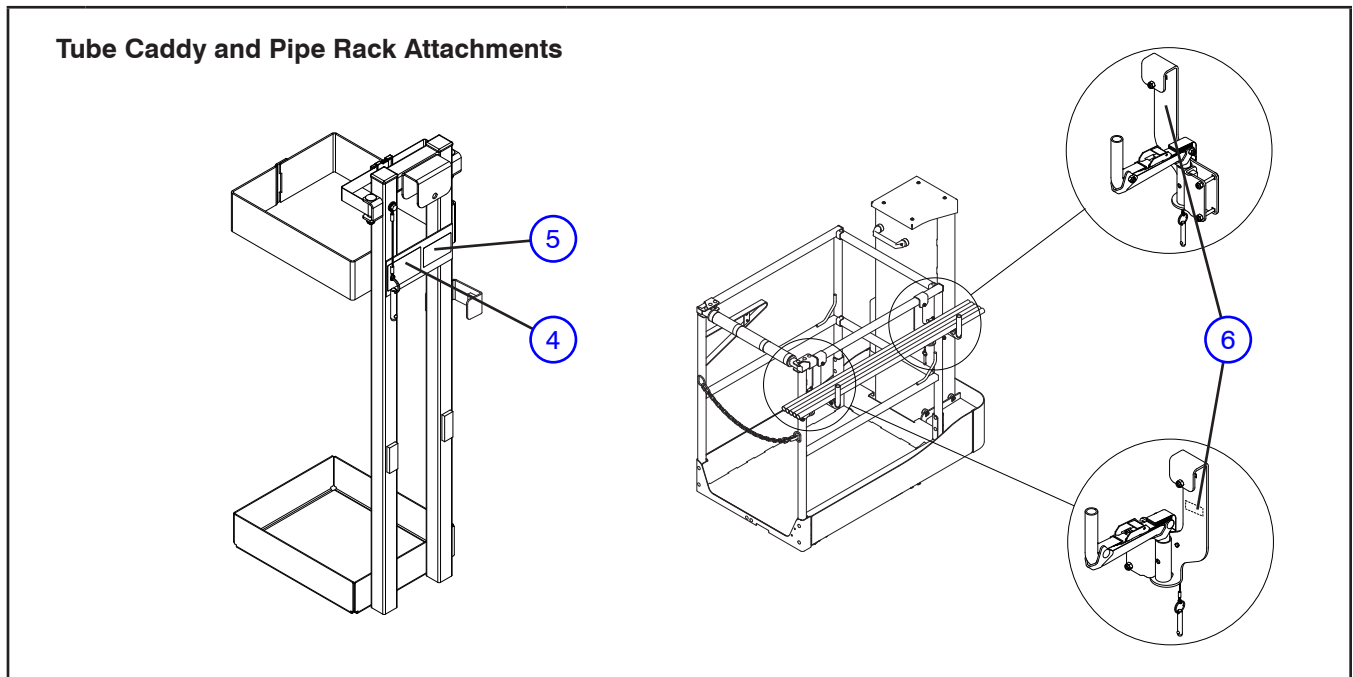

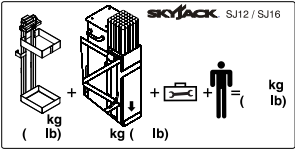
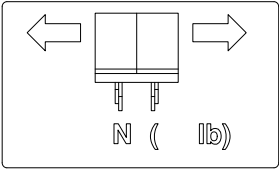
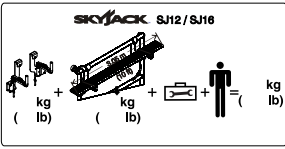
Nº	Label Pictorial	Description
4		<p>Tube Caddy Capacity Indicates tube caddy capacity.</p>
5		<p>Manual Force Maximum manual side force.</p>
6		<p>Pipe Rack Capacity Indicates pipe rack capacity.</p>

Labels - Models SJ12 & SJ16 - Options and Attachments

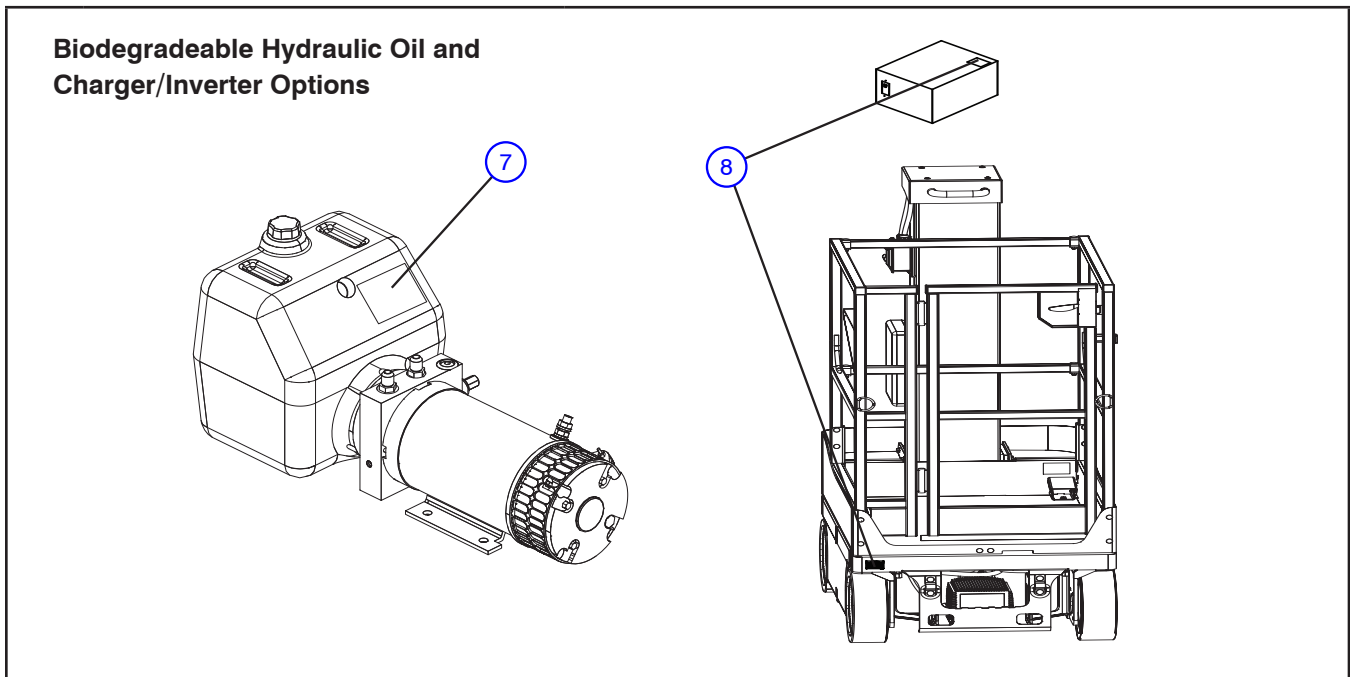

Nº	Label Pictorial	Description
7	 <p>HYDRAWAY BIO SE 32-68 (STATOIL)</p>	<p>Hydraway Bio SE32-68</p> <p>Replace with Hydraway Bio SE32-68 only.</p>
8	<p>NOTICE</p> <p>This aerial platform is equipped with inverter power supply. Main power disconnect switch must be turned to © off position at the end of every shift.</p>	<p>Inverter Notice</p> <p>This aerial platform is equipped with inverter power supply. Main power disconnect switch must be turned to “○” off position at the end of every shift.</p>



WARNING

Cancer and Reproductive Harm-

<https://www.p65warnings.ca.gov/>.

SKYJACK[™]

www.skyjack.com