



# **DIESEL RT SCISSOR LIFT**

## **SR1623D**

### **(SR5390D)**

#### **HIGHLIGHTS**

LGMG SR23D Series rough terrain scissor lifts deliver higher capacities and larger platforms for the most tough construction job sites. Four-wheel drive, oscillating axels and hydraulic outriggers provide superior stability on the most tough uneven surfaces.

- Larger working platform with dual extension decks offers great productivity.
- Powerful diesel engine, oscillating axels and four-wheel drive provide better performance on most rough terrain job sites.
- Standard features with one button auto leveling outriggers, overload system, motion alarm, help the operator to complete the job in a much safer way.
- Pull-out engine tray for easy access and maintenance.
- On-board self-diagnosis system makes it easier for quick troubleshooting.



# LGMG SR23D Series

## SPECIFICATIONS

| MODELS                                 | SR1623D (SR5390D)           |            |
|--|-----------------------------|------------|
| Measurements                           | Metric                      | US         |
| Working Height Max.                    | 17.9m                       | 58.7ft     |
| <b>A</b> Platform Height-Raised        | 15.9m                       | 52.2ft     |
| <b>B</b> Platform Height-Stowed        | 2.08m                       | 81.9ft     |
| <b>C</b> Platform Length               | 3.98m                       | 13ft       |
| <b>D</b> Platform Width                | 1.83m                       | 6ft        |
| <b>E</b> Overall Length(with ladder)   | 4.9m                        | 16ft       |
| <b>F</b> Overall Width                 | 2.3m                        | 7.55ft     |
| <b>G</b> Overall Height-Rails Up       | 3.18m                       | 10.45ft    |
| Overall Height-Rails Down              | 2.5m                        | 8.2ft      |
| Extension Deck (Front/Rear)            | 1.45/1.14m                  | 4.75/3.7ft |
| <b>H</b> Wheelbase                     | 2.85m                       | 111.2in    |
| Ground Clearance-Center                | 0.23m                       | 0.75ft     |
| PRODUCTIVITY                           |                             |            |
| Platform Occupants Max. (in/out)       | 4/4                         | 4/4        |
| Platform Capacity                      | 680kg                       | 1500lbs    |
| Platform Capacity-Extension            | 230kg                       | 510lbs     |
| Drive Height                           | 8.5m                        | 27.9ft     |
| Gradeability-Stowed                    | 40%                         |            |
| Turning Radius-Outside                 | 5.33m                       | 17.45ft    |
| Raise/Lower Speed                      | 55/55s                      |            |
| Brakes                                 | Four-wheel Brake            |            |
| Drive Mode                             | 4×4                         |            |
| Tires Type                             | Solid                       |            |
| Tires Size                             | 835×290mm                   | 33×12in    |
| POWER                                  |                             |            |
| Power Source                           | Deutz D2.9 L4 36.4kw/48.8hp |            |
| Fuel Tank Capacity                     | 110L                        | 30gal      |
| HYDRAULIC SYSTEM                       |                             |            |
| Hydraulic Oil Capacity                 | 140L                        | 37gal      |
| WEIGHT                                 |                             |            |
| Machine Weight(6.58m platform,CE/ANSI) | 8100kg                      | 17860lbs   |
| Machine Weight (7.4m platform,CE/ANSI) | 8200kg                      | 18080lbs   |

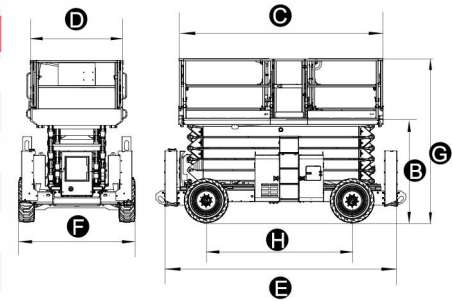

## STANDARD FEATURES

- Proportional control
- Tilt alarm with lift cut-out
- Overload sensing system
- Descent alarm with flashing beacon
- Selflock entry gate
- Auto-leveling outriggers
- Emergency stop button
- On-board diagnostic system
- Oscillating axle
- Four-wheel drive and break
- Horn/Hour meter
- Emergency descent

## OPTIONAL

- 6.58m/7.4m platform extension
- AC power to platform
- Platform anti-collision device
- Hydraulic generator
- Solid non-marking tires
- Foam-filled tires
- Foam-filled non-marking tires

### Machines in compliant with EN280 / ANSI 92.20 Standard.

Specifications subject to change without notice. Photos and diagrams in the page are for promotional purposes only.  
2020 V1 Version

### LINGONG GROUP JINAN HEAVY MACHINERY CO., LTD.

Address: No. 2676, Kejia Road, Jinan, Shandong, China  
Email: sales@lgmg.com.cn Tel:+86-0531-67879283

### LGMG Europe B.V.

Address: Laanweg 16 3208LC Spijkenisse Rotterdam, The Netherlands

### LGMG North America, Inc.

Address: 1445 Sheffler Dr, Chambersburg, PA. 17201, USA



RELIABILITY IN ACTION