

SELF-PROPELLED SCISSOR LIFTS

OPERATOR'S MANUAL

with Maintenance Information

JCPT0807HA/AC JCPT0808HA/AC JCPT1008HA/AC JCPT1012HA/AC
JCPT1212HA/AC JCPT1412HA/AC JCPT1614HA/AC

(Hydraulic Motor Drive / Electric Motor Drive)



WARNING

THE MANUFACTURER SHALL NOT BE HELD LIABLE IN CASE OF FAULTS OR ACCIDENTS DUE TO NEGLIGENCE, INCAPACITY, INSTALLATION BY UNQUALIFIED TECHNICIANS AND IMPROPER USE OF THE MACHINE

DO NOT OPERATE THIS MACHINE UNTIL YOU READ AND UNDERSTAND ALL THE DANGERS, WARNINGS AND CAUTIONS IN THIS MANUAL

Part Number: SM0121111_Rev2.0

ANSI

Zhejiang Dingli Machinery Co., Ltd.

Second Edition, May 2021 Printing

Version of the Record

Version of the Record

| Version Number | Create Date |
|------------------------|-------------|
| SM0121111_Rev1.0 | 2021-03 |
| SM0121111_Rev2.0 | 2021-03 |

Important

Read, understand and obey these safety rules and operating instructions before operating this machine.

Only trained and authorized personnel shall be permitted to operate this machine. This manual should be considered a permanent part of your machine and should remain with the machine at all times. If you have any questions, please call DINGLI Machinery.

Contents

| | Page |
|------------------------------------|------|
| Safety Rules | 1 |
| Legend | 9 |
| Decals | 10 |
| Specifications | 18 |
| Control panel | 32 |
| Pre-operation Inspection | 36 |
| Workplace Inspection | 38 |
| Function Tests | 39 |
| Operating Instructions | 44 |
| Transport and Lifting Instructions | 61 |
| Maintenance | 65 |
| Schematic | 90 |
| Inspection and Repair Log | 104 |

Owners, Users and operators:

We appreciate your choice of our machine for your application. Our number one priority is user safety, which is best achieved by our joint efforts. We feel that you make a major contribution to safety if you, as the equipment users and operators:

- 1 Comply with employer, job site and governmental rules.
- 2 Read, understand and follow the instructions in this and other manuals supplied with this machine.
- 3 Use good safe work practices in a commonsense way.
- 4 Only have trained / certified operators, directed by informed and knowledgeable supervision, running the machine.

If there is anything in this manual that is not clear or which you believe should be added, please contact us.

Contact us:

Zhejiang Dingli Machinery Co., Ltd.

1255 Baiyun South Road. Leidian Town.

Deqing Zhejiang

China

Tel: +86-572-8681688

Fax: +86-572-8681690

Web: www.cndingli.com

E-mail: market@cndingli.com

Safety Rules



Danger

Failure to obey the instructions and safety rules in this manual will result in death or serious injury.

Do Not Operate Unless:

- You learn and practice the principles of safe machine operation contained in this operator's manual.
 - 1 Avoid hazardous situations.**
 - Know and understand the safety rules before going on to the next section.**
 - 2 Always perform a pre-operation inspection.
 - 3 Always perform function tests prior to use.
 - 4 Inspect the workplace.
 - 5 Only use the machine as it was intended.
- You read, understand and obey the manufacturer's instructions and safety rules — operator's manual and machine decals.
- You read, understand and obey employer's safety rules and worksite regulations.
- You read, understand and obey all applicable governmental regulations.
- You are properly trained to safely operate the machine.

Decal Legend

DINGLI product decals use symbols, color coding and signal words to identify the following:



Safety alert symbol — used to alert personnel to potential personal injury hazards. Obey all safety messages that follow this symbol to avoid possible injury or death.

▲ DANGER Red — used to indicate the presence of an imminently hazardous situation which, if not avoided, will result in death or serious injury.

▲ WARNING Orange — used to indicate the presence of a potentially hazardous situation which, if not avoided, could result in death or serious injury.

▲ CAUTION Yellow with safety alert symbol — used to indicate the presence of a potentially hazardous situation which, if not avoided, may cause minor or moderate injury.

NOTICE Blue without safety alert symbol — used to indicate the presence of a potentially hazardous situation which, if not avoided, may result in property damage.

Safety Rules

The relevant conditions of using the equipment

The surface of work ground should be flat and hard with no obstacles in air and the safety distance between the equipment and high-tension line is adequate.

The environment temperature should be within -20°C~40°C; Height above sea level ≤1000m.

The environment humidity ≤ 90%.

Electrical power: AC 110~230V±10%, 50~60Hz.

Intended Use

This machine is intended to be used only to lift personnel, along with their tools and materials to an aerial work site.

Safety Sign Maintenance

Replace any missing or damaged safety signs. Keep operator safety in mind at all times. Use mild soap and water to clean safety signs. Do not use solvent-based cleaners because they may damage the safety sign material.

⚠ Electrocuting Hazard

This machine is not electrically insulated and will not provide protection from contact with or proximity to electrical current.

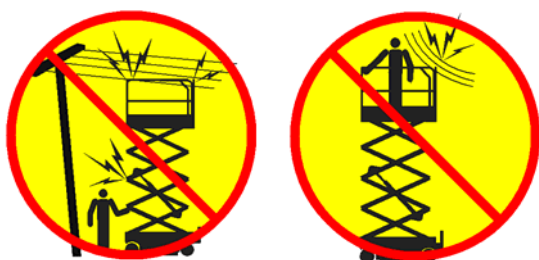

Maintain safe distances from electrical power lines and apparatus in accordance with applicable governmental regulations and the following chart.

| Voltage Phase to Phase | Minimum Safe Approach Distance | |
|------------------------|--------------------------------|--------|
| 0 to 300V | Avoid Contact | |
| 300V to 50kV | 10ft | 3.05m |
| 50kV to 200kV | 15ft | 4.60m |
| 200kV to 350kV | 20ft | 6.10m |
| 350kV to 500kV | 25ft | 7.62m |
| 500kV to 750kV | 35ft | 10.67m |
| 750kV to 1000kV | 45ft | 13.72m |

Allow for platform movement, electrical line sway or sag and beware of strong or gusty winds.

Keep away from the machine if it contacts energized power lines. Personnel on the ground or in the platform must not touch or operate the machine until energized power lines are shut off.

Do not operate the machine during lightning or storms.

Do not use the machine as a ground for welding.

⚠ Tip-over Hazard

Occupants, equipment and materials must not exceed the maximum platform capacity or the maximum capacity of the platform extension.

Maximum capacity – JCPT0807HA/AC

| | |
|---------------------------------------|----------------|
| Maximum occupants | 2 |
| Platform allowable maximum load | 500 lbs/227 kg |
| Extension deck allowable maximum load | 250 lbs/113 kg |

Maximum capacity – JCPT0808HA/AC

| | |
|-------------------|---|
| Maximum occupants | 2 |
|-------------------|---|

Safety Rules

Platform allowable maximum load
840 lbs/380 kg

Extension deck allowable maximum load
250 lbs/113 kg

Maximum capacity – JCPT1008HA/AC

Maximum occupants 2

Platform allowable maximum load
500 lbs/227 kg

Extension deck allowable maximum load
250 lbs/113 kg

Maximum capacity – JCPT1012HA/AC

Maximum occupants 3

Platform allowable maximum load
1000 lbs/454 kg

Extension deck allowable maximum load
250 lbs/113 kg

Maximum capacity – JCPT1212HA/AC

Maximum occupants 2

Platform allowable maximum load
700 lbs/318 kg

Extension deck allowable maximum load
250 lbs/113 kg

Maximum capacity – JCPT1412HA/AC

Maximum occupants 2

Platform allowable maximum load
550 lbs/250 kg

Extension deck allowable maximum load
250 lbs/113 kg

Maximum capacity – JCPT1614HA/AC

Maximum occupants 2

Platform allowable maximum load
500 lbs/227 kg

Extension deck allowable maximum load
250 lbs/113 kg

Platform retracted



Platform extended



Extension only Platform only

Work Area Safety

Do not raise the platform unless the machine is on a firm, level surface.

Do not drive over 0.5 mph / 0.8 km/h with the platform raised.



Do not depend on the tilt alarm as a level indicator. The tilt alarm sounds on the chassis and in the platform when the machine is on a slope.

If the tilt alarm sounds:

Lower the platform. Move the machine to a firm, level surface. If the tilt alarm sounds when the platform is raised, use extreme caution to lower the platform.

Do not operate the machine in strong or gusty winds. Do not increase the surface area of the platform or the load. Increasing the area exposed to the wind will decrease machine stability.



Safety Rules

Do not use the platform controls to free a platform that is caught, snagged or otherwise prevented from normal motion by an adjacent structure. All personnel must be removed from the platform before attempting to free the platform using the ground controls.

Use extreme care and slow speeds while driving the machine in the stowed position across uneven terrain, debris, unstable or slippery surfaces and near holes and drop-offs.

Do not drive the machine on or near uneven terrain, unstable surfaces or other hazardous conditions with the platform raised.

Do not push off or pull toward any object outside of the platform.



| Model | Maximum allowable side force | Maximum number of occupants |
|------------|------------------------------|-----------------------------|
| JCPT0807HA | 100 lbs / 445 N | 2 |
| JCPT0808HA | 126 lbs / 560N | 2 |
| JCPT1008HA | 100 lbs / 445 N | 2 |
| JCPT1012HA | 150 lbs / 667 N | 3 |
| JCPT1212HA | 105 lbs / 467 N | 2 |
| JCPT1412HA | 100 lbs / 445 N | 2 |
| JCPT1614HA | 100 lbs / 445 N | 2 |
| JCPT0807AC | 100 lbs / 445 N | 2 |
| JCPT0808AC | 126 lbs / 560 N | 2 |
| JCPT1008AC | 100 lbs / 445 N | 2 |
| JCPT1012AC | 150 lbs / 667 N | 3 |

| Model | Maximum allowable side force | Maximum number of occupants |
|------------|------------------------------|-----------------------------|
| JCPT1212AC | 105 lbs / 467 N | 2 |
| JCPT1412AC | 100 lbs / 445 N | 2 |
| JCPT1614AC | 100 lbs / 445 N | 2 |

Do not use the machine as a crane.

Do not place or attach fixed or overhanging loads to any part of this machine.

Do not push the machine or other objects with the platform.

Do not operate the machine with the chassis trays open.

Do not contact adjacent structures with the platform

Do not alter or disable the limit switches.

Do not tie the platform to adjacent structures.

Do not place loads outside the platform perimeter.



Do not alter or disable machine components that in any way affect safety and stability.

Do not replace items critical to machine stability with items of different weight or specification.

Do not use batteries that weigh less than the original equipment. Batteries are used as counterweight and are critical to machine stability.

The lithium battery: Each battery must weigh 110 lbs /50 kg. (For JCPT0807HA/AC, JCPT0808HA/AC, JCPT1008HA/AC, and

Safety Rules

JCPT1012HA/AC); each battery must weigh 137 lbs / 62 kg. (For JCPT1212HA/AC, JCPT1412HA/AC, and JCPT1614HA/AC).

The lead-acid battery: Each battery must weigh 62 lbs / 28 kg. The batteries must weigh a minimum of 248 lbs / 112 kg. (For JCPT0807HA/AC, JCPT0808HA/AC, JCPT1008HA/AC, JCPT1012HA/AC); Each battery must weigh 66 lbs / 30 kg. The batteries must weigh a minimum of 264 lbs / 120 kg (For JCPT1212HA/AC); Each battery must weigh 82 lbs / 37 kg. The batteries must weigh a minimum of 328 lbs / 148 kg (For JCPT1412HA/AC, JCPT1614HA/AC).

Do not modify or alter an aerial work platform without prior written permission from the manufacturer. Mounting attachments for holding tools or other materials onto the platform, toe boards or guard rail system can increase the weight in the platform and the surface area of the platform or the load.

Do not place ladders or scaffolds in the platform or against any part of this machine.

Do not transport tools and materials unless they are evenly distributed and can be safely handled by person(s) in the platform.

Do not use the machine on a moving or mobile surface or vehicle.

Be sure all tires are in good condition, air-filled tires are properly inflated and lug nuts are properly tightened.

▲ Crushing Hazard

Keep hands and limbs out of scissors.

Keep hands clear when folding rails.

Maintain a firm grasp on the platform rail when removing the rail pins. Do not allow the platform guard rails to fall.

Use common sense and planning when operating the machine with the controller from the ground. Maintain safe distances between the operator, the machine and fixed objects.

▲ Operation on Slopes Hazard

Do not drive the machine on a slope that exceeds the slope and side slope rating of the machine.

Slope rating applies to machines only in the stowed position.



Maximum slope rating stowed

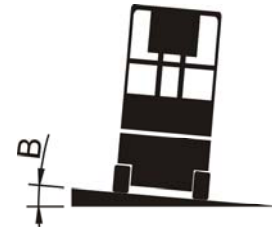

Maximum side slope rating stowed

| Model | A | B |
|------------|-----------|----|
| JCPT0807HA | 25% (14°) | 3° |
| JCPT0808HA | 25% (14°) | 5° |
| JCPT1008HA | 25% (14°) | 5° |
| JCPT1012HA | 25% (14°) | 5° |
| JCPT1212HA | 25% (14°) | 5° |
| JCPT1412HA | 25% (14°) | 5° |
| JCPT1614HA | 25% (14°) | 5° |
| JCPT0807AC | 25% (14°) | 3° |
| JCPT0808AC | 25% (14°) | 5° |
| JCPT1008AC | 25% (14°) | 5° |
| JCPT1012AC | 25% (14°) | 5° |
| JCPT1212AC | 25% (14°) | 5° |
| JCPT1412AC | 25% (14°) | 5° |
| JCPT1614AC | 25% (14°) | 5° |

Note: Slope rating is subject to ground conditions and adequate traction.

Safety Rules

▲ Fall Hazard

The guard rail system provides fall protection. During operation, occupants in the platform must wear a full body harness with a lanyard attached to an authorized lanyard anchorage point. Attach only one (1) lanyard per lanyard anchorage point.

Do not sit, stand or climb on the platform guard rails. Maintain a firm footing on the platform floor at all times.



Do not climb down from the platform when raised.

Keep the platform floor clear of debris.

Close the entry gate before operating.

Do not operate the machine unless the guard rails are properly installed and the entry is secured for operation.

Do not enter or exit the platform unless the machine is in the stowed position.

▲ Collision Hazard



Be aware of limited sight distance and blind spots when driving or operating.

Be aware of extended platform position(s) when moving the machine.

Check the work area for overhead obstructions or other possible hazards.



Be aware of crushing hazards when grasping the platform guard rail.

Operators must comply with employer, job site and governmental rules regarding use of personal protective equipment.

Observe and use color-coded direction arrows on the platform controls for drive and steer functions.

Do not operate a machine in the path of any crane or moving overhead machinery unless the controls of the crane have been locked out and/or precautions have been taken to prevent any potential collision.

No stunt driving or horseplay while operating a machine.

Do not lower the platform unless the area below is clear of personnel and obstructions.



Limit travel speed according to the condition of the ground surface, congestion, slope, location of personnel, and any other factors which may cause collision.

▲ Component Damage Hazard

Do not use any battery charger greater than 24V to charge the batteries.

Do not use the machine as a ground for welding.

Safety Rules

⚠ Explosion and Fire Hazard

Do not operate the machine or charge the batteries in hazardous locations where potentially flammable or explosive gases or particles may be present.

⚠ Damaged Machine Hazard

Do not use a damaged or malfunctioning machine.

Conduct a thorough pre-operation inspection of the machine and test all functions before each work shift. Immediately tag and remove from service a damaged or malfunctioning machine.

Be sure all maintenance has been performed as specified in this manual. Be sure all decals are in place and legible.

Be sure the operator's manual is complete, legible and in the storage container located in the platform.

⚠ Bodily Injury Hazard

Do not operate the machine with a hydraulic oil or air leak. An air leak or hydraulic leak can penetrate and/or burn skin.

Improper contact with components under any cover will cause serious injury. Only trained maintenance personnel should access compartments. Access by the operator is only advised when performing a pre-operation inspection. All compartments must remain closed and secured during operation.

⚠ Battery Safety

⚠ Burn Hazard



Batteries contain acid. Always wear protective clothing and eye wear when working with batteries.

Avoid spilling or contacting battery acid. Neutralize battery acid spills with baking soda and water.

Rinse eyes or skin splashed with acid using plenty of clean water and consult a doctor immediately. Wash clothing contaminated with acid with plenty of water.

⚠ Explosion Hazard



Keep sparks, flames and lighted tobacco away from batteries. Batteries emit explosive gas.

Avoid fire and risk of explosion caused by short circuits.

The battery tray should remain open during the entire charging cycle.

Do not contact the battery terminals or the cable clamps with tools that may cause sparks.

⚠ Component Damage Hazard

Do not use any battery charger greater than 24V to charge the batteries.

Pressure relief valves are used as breathable plugs. If open the pressure relief valves, the battery will be destroyed.

The battery must always be kept clean and dry in order to prevent leakage currents. Do not rinse with water or wipe with a wet towel.

Safety Rules

Please do not change the location of the battery, and cannot be inverted. Do not block the vent hole of safety valve when placing.

The series/parallel connection must be approved by Dingli. Only accessories approved by Dingli can be used for connection of battery blocks.

▲ Electrocutation/ Burn Hazard



Connect the battery charger to a grounded, AC 3-wire electrical outlet only.

Inspect daily for damaged cords, cables and wires.

Replace damaged items before operating.

Metallic parts of the battery cells are always electriferous. Therefore, no foreign objects or tools may be placed on the batteries.

Avoid electrical shock from contact with battery terminals. Remove all rings, watches and other jewelry.

▲ Tip-over Hazard

Do not use batteries that weigh less than the original equipment. Batteries are used as counterweight and are critical to machine stability.

The lithium battery: Each battery must weigh 110 lbs /50 kg. (For JCPT0807HA/AC, JCPT0808HA/AC, JCPT1008HA/AC, and JCPT1012HA/AC); each battery must weigh 137 lbs /62 kg. (For JCPT1212HA/AC, JCPT1412HA/AC, and JCPT1614HA/AC).

The lead-acid battery: Each battery must weigh 62 lbs / 28 kg. The batteries must weigh a minimum of 248 lbs / 112 kg. (For JCPT0807HA/AC, JCPT0808HA/AC, JCPT1008HA/AC, JCPT1012HA/AC); Each battery must weigh 66 lbs / 30 kg. The batteries must weigh a minimum of 264 lbs / 120 kg (For JCPT1212HA/AC); Each battery must weigh 82 lbs / 37 kg. The batteries must weigh a minimum of 328 lbs / 148 kg (For JCPT1412HA/AC, JCPT1614HA/AC).

▲ Lifting Hazard

Use the appropriate number of people and proper lifting techniques when lifting batteries.

When lifting hooks must not cause any damage to cells, connectors and connecting cables.

▲ Environmental Hazard

30°C battery temperature is considered the rated temperature. Higher temperatures reduce the service life, while lower temperatures reduce the available capacity.45°C is the upper limit temperature and is not permissible as an operating temperature.

Batteries must not be exposed to sunlight without protection.

▲ Transportation and storage Hazard

Charge the battery as soon as receive the machine or after long distance transportation

When the battery is stored for a long time, it needs to be charged regularly. Failure to charge in time may permanently damage the battery.

▲ pollute Hazard



Old batteries with this marking are recyclable goods and must be sent for recycling.

Used batteries which are not sent for recycling are to be disposed of as special waste under the relevant regulations.

Lockout after Each Use

- 1 Select a safe parking location - firm level surface, clear of obstruction and traffic.
- 2 Lower the platform.
- 3 Turn the key switch to the off position and remove the key to secure from unauthorized use.
- 4 Push in the red Emergency Stop buttons to "off" position.
- 5 Push in the main power switch to "off" position.
- 6 Chock the wheels.
- 7 Charge the batteries.

Legend

Legend

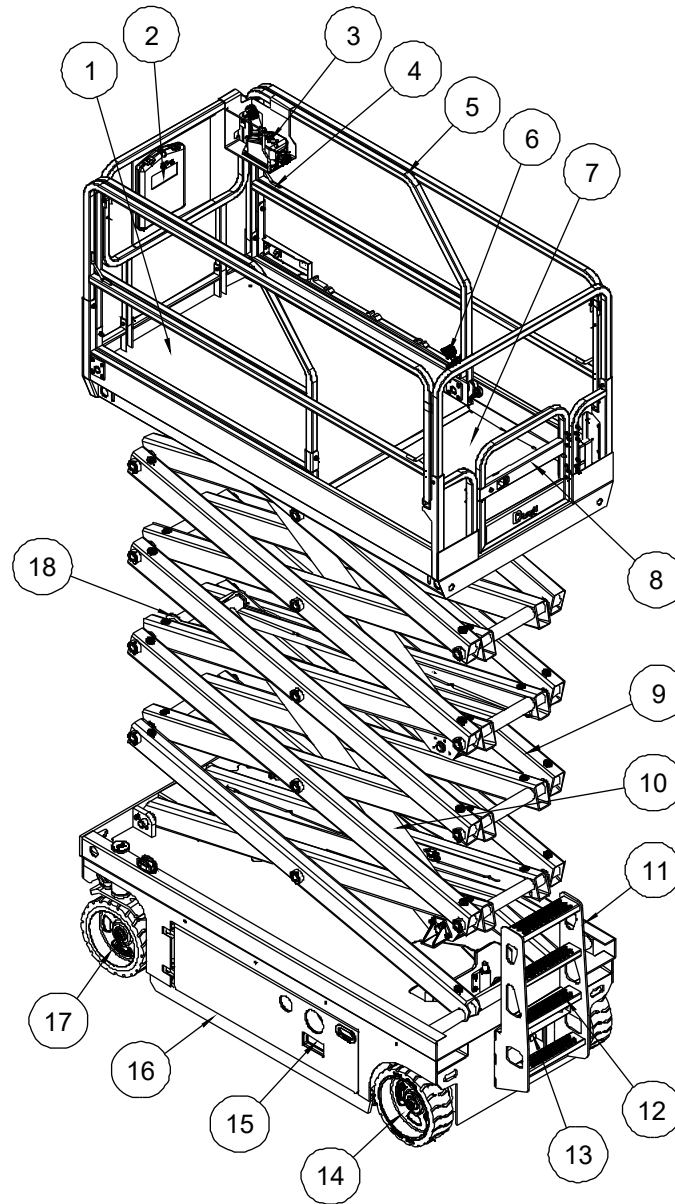

1 Platform extension

2 Manual storage container

3 Platform control

4 Lanyard anchorage point

5 Platform guard rails

6 Platform extension release pedal

7 Main platform

8 Platform entry gate

9 Scissor arms

10 Lift cylinder

11 Ground controls (on opposite side of machine)

12 Entry ladder

13 Brake release pump

14 Non-steer tire

15 Battery charger

16 Pothole guard

17 Steer tire

18 Safety arm

Decals**Decal Inspection**

Use the pictures on the next page to verify that all decals are legible and in place.

Below is a numerical list with quantities and descriptions.

JCPT0807HA/AC

| No. | Part No. | Description | Qty. | Remark |
|-----|----------|--|------|--------|
| 1 | 09440011 | Decal, Label-Lanyard anchorage point | 4 | |
| 2 | 09340001 | Decal, Notice-Keep the manual with the machine | 1 | |
| 3 | 09440003 | Decal, Danger-Tip-over hazard, tilt-alarm | 1 | |
| 4 | 09440037 | Decal, Danger-General safety rules | 1 | |
| 5 | 09340005 | Decal, Instructions-Platform controller normal position | 1 | |
| 6 | 09340003 | Decal, Instructions-Refer the operator to the instructions for use | 2 | |
| 7 | 09440029 | Decal, Label-Capacity 500 lbs | 2 | |
| 8 | 09310001 | Decal, Instructions-Forklift pockets | 2 | |
| 9 | 09310003 | Decal, Instructions-Tie down point | 4 | |
| 10 | 09310002 | Decal, Instructions-Lift point | 4 | |
| 11 | 09310235 | Decal, Instructions-Maximum wheel load 1562 lbs | 4 | |
| 12 | 09310064 | Decal, Notice-Main power switch operation | 1 | |
| 13 | 09410007 | Decal, Warning-Change battery | 1 | |
| 14 | 09410129 | Decal, Warning-Charge warning | 1 | |
| 15 | 09410001 | Decal, Danger-Explosion/burn hazard | 1 | |
| 16 | 09330001 | Decal, Danger-Safety arm | 2 | |
| 17 | 09440019 | Decal, Caution-Max. manual force 100 lbs | 2 | |
| 18 | 09640123 | Decal, Label-JCPT0807HA (JCPT0807HA) | 2 | |
| | 09640122 | Decal, Label-JCPT0807AC (JCPT0807AC) | 2 | |
| 19 | 09410005 | Decal, Danger-Do not alter or disable limit switch | 1 | |
| 20 | 09430003 | Decal, Danger-Keep away from moving parts | 1 | |
| 21 | 09310004 | Decal, Instructions-Emergency lower | 1 | |
| 22 | 09410013 | Decal, Warning-Inspected and operation properly | 1 | |

Decals

JCPT0807HA/AC

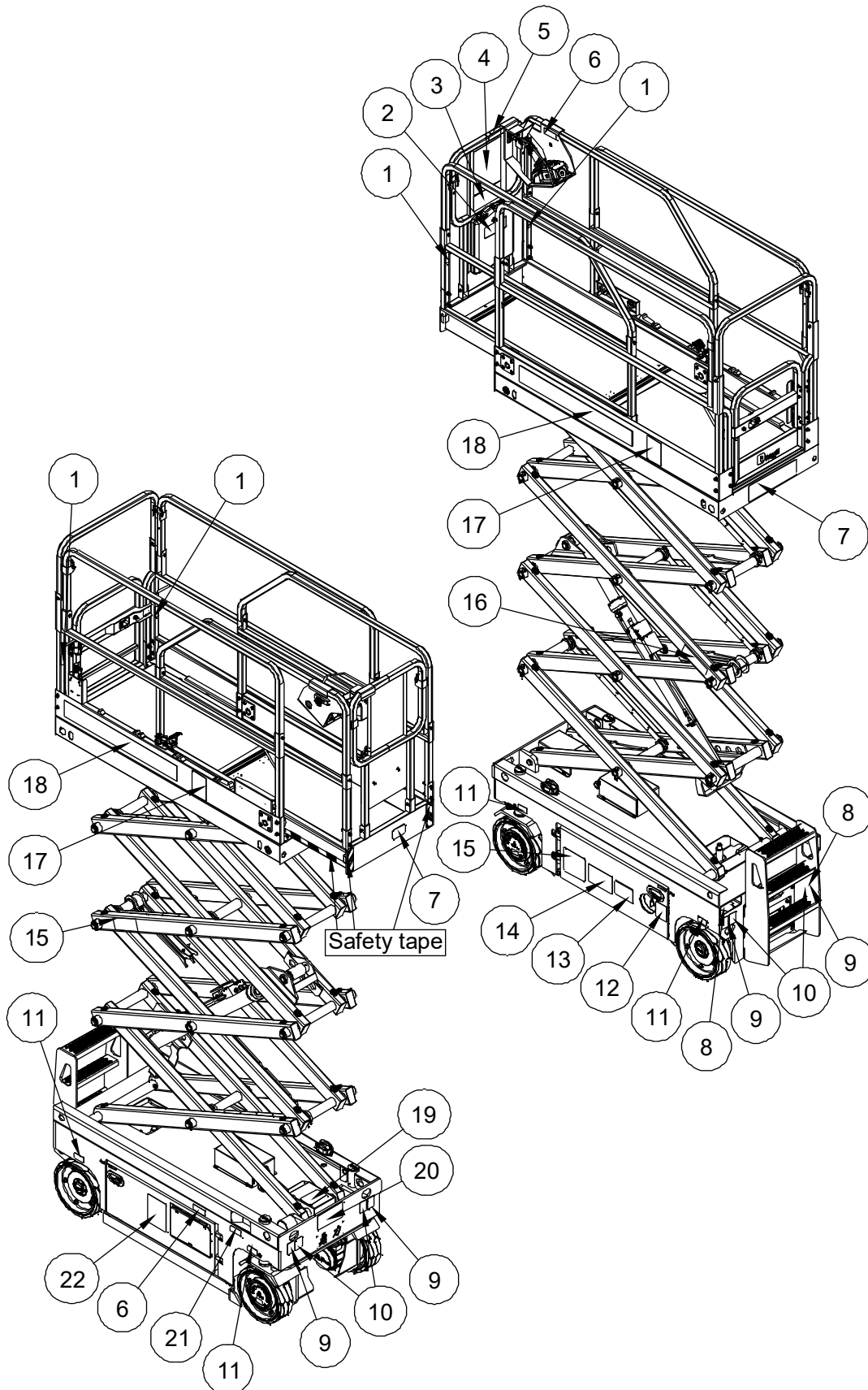

JCPT0807HA/AC

① 09440011



⑤ 09340005



⑥ 09340003



⑦ 09440029



⑨ 09310003



⑩ 09310002



⑫ 09310064



⑮ 09410001



⑰ 09440019



⑱ 09640123

JCPT0807HA

⑱ 09640122

JCPT0807AC

② 09340001



③ 09440003



④ 09440037



⑧ 09310001



⑬ 09410007



⑯ 09330001



⑲ 09410005



⑳ 09430003



㉑ 09310004



㉒ 09410013



Decals**JCPT0808HA/AC~JCPT1614HA/AC**

| No. | Part No. | Description | Qty. | Remark |
|-----|----------|--|------|---|
| 1 | 09440011 | Decal, Label-Lanyard anchorage point | 4 | |
| 2 | 09340001 | Decal, Notice-Keep the manual with the machine | 1 | |
| 3 | 09440037 | Decal, Danger-General safety rules | 1 | |
| 4 | 09440003 | Decal, Danger-Tip-over hazard, tilt-alarm | 1 | |
| 5 | 09340005 | Decal, Instructions-Platform controller normal position | 1 | |
| 6 | 09340003 | Decal, Instructions-Refer the operator to the instructions for use | 2 | |
| 7 | 09440027 | Decal, Label-Capacity 840 lbs | 2 | JCPT0808HA/AC |
| | 09440029 | Decal, Label-Capacity 500 lbs | 2 | JCPT1008HA/AC JCPT1614HA/AC |
| | 09440031 | Decal, Label-Capacity 1000 lbs | 2 | JCPT1012HA/AC |
| | 09440033 | Decal, Label-Capacity 700 lbs | 2 | JCPT1212HA/AC |
| | 09440035 | Decal, Label-Capacity 550 lbs | 2 | JCPT1412HA/AC |
| 8 | 09310001 | Decal, Instructions-Forklift pockets | 2 | |
| 9 | 09310003 | Decal, Instructions-Tie down point | 4 | |
| 10 | 09310002 | Decal, Instructions-Lift point | 4 | |
| 11 | 09310020 | Decal, Instructions-Maximum wheel load 2112 lbs | 4 | JCPT0808HA/AC JCPT1008HA/AC |
| | 09310021 | Decal, Instructions-Maximum wheel load 2376 lbs | 4 | JCPT1012HA/AC |
| | 09310023 | Decal, Instructions-Maximum wheel load 2508 lbs | 4 | JCPT1212HA/AC |
| | 09310025 | Decal, Instructions-Maximum wheel load 2948 lbs | 4 | JCPT1412HA/AC |
| | 09310026 | Decal, Instructions-Maximum wheel load 3124 lbs | 4 | JCPT1614HA/AC |
| 12 | 09310006 | Decal, Notice-Main power switch operation | 1 | |
| 13 | 09410007 | Decal, Warning-Change battery | 1 | JCPT0808HA/AC JCPT1008HA/AC JCPT1012HA/AC |
| | 09410009 | Decal, Warning-Change battery | 1 | JCPT1212HA/AC |
| | 09410011 | Decal, Warning-Change battery | 1 | JCPT1412HA/AC JCPT1614HA/AC |
| 14 | 09410129 | Decal, Warning-Charge warning | 1 | |
| 15 | 09410001 | Decal, Danger-Explosion/burn hazard | 1 | |

Decals

| No. | Part No. | Description | Qty. | Remark |
|----------|----------------------------|--|------------|---|
| 16 | 09430003 | Decal, Danger-Keep away from moving parts | 3 | JCPT0808HA/AC, JCPT1008HA/AC, JCPT1012HA/AC, JCPT1212HA/AC |
| | 09430003 | Decal, Danger-Keep away from moving parts | 5 | JCPT1412HA/AC, JCPT1614HD/DC |
| 17 | 09430001 | Decal, Danger-Safety arm | 2 | JCPT0808HA/AC, JCPT1008HA/AC, JCPT1012HA/AC, JCPT1212HA/AC |
| | 09430001 | Decal, Danger-Safety arm | 4 | JCPT1412HA/AC, JCPT1614HD/DC |
| 18 | 09440021 | Decal, Caution-Max. manual force 126 lbs | 2 | JCPT0808HA/AC |
| | 09440019 | Decal, Caution-Max. manual force 100 lbs | 2 | JCPT1008HA/AC, JCPT1412HA/AC, JCPT1614HA/AC |
| | 09440023 | Decal, Caution-Max. manual force 150 lbs | 2 | JCPT1012HA/AC |
| | 09440025 | Decal, Caution-Max. manual force 105lbs | 2 | JCPT1212HA/AC |
| 19 | 09640124 | Decal, Cosmetic-JCPT0808HA | 2 | JCPT0808HA |
| | 09640125 | Decal, Cosmetic-JCPT0808AC | 2 | JCPT0808AC |
| | 09640126 | Decal, Cosmetic-JCPT1008HA | 2 | JCPT1008HA |
| | 09640127 | Decal, Cosmetic-JCPT1008AC | 2 | JCPT1008AC |
| | 09640128 | Decal, Cosmetic-JCPT1012HA | 2 | JCPT1012HA |
| | 09640129 | Decal, Cosmetic-JCPT1012AC | 2 | JCPT1012AC |
| | 09640130 | Decal, Cosmetic-JCPT1212HA | 2 | JCPT1212HA |
| | 09640131 | Decal, Cosmetic-JCPT1212AC | 2 | JCPT1212AC |
| | 09640132 | Decal, Cosmetic-JCPT1412HA | 2 | JCPT1412HA |
| | 09640133 | Decal, Cosmetic-JCPT1412AC | 2 | JCPT1412AC |
| | 09640116 | Decal, Cosmetic-JCPT1614HA | 2 | JCPT1614HA |
| 09640117 | Decal, Cosmetic-JCPT1614AC | 2 | JCPT1614AC | |
| 20 | 09410005 | Decal, Danger-Do not alter or disable limit switch | 1 | |
| 21 | 09310004 | Decal, Instructions-Emergency lower | 1 | |
| 22 | 09410013 | Decal, Warning-Inspected and operation properly | 1 | |

Decals

JCPT0808HA/AC~JCPT1614HA/AC

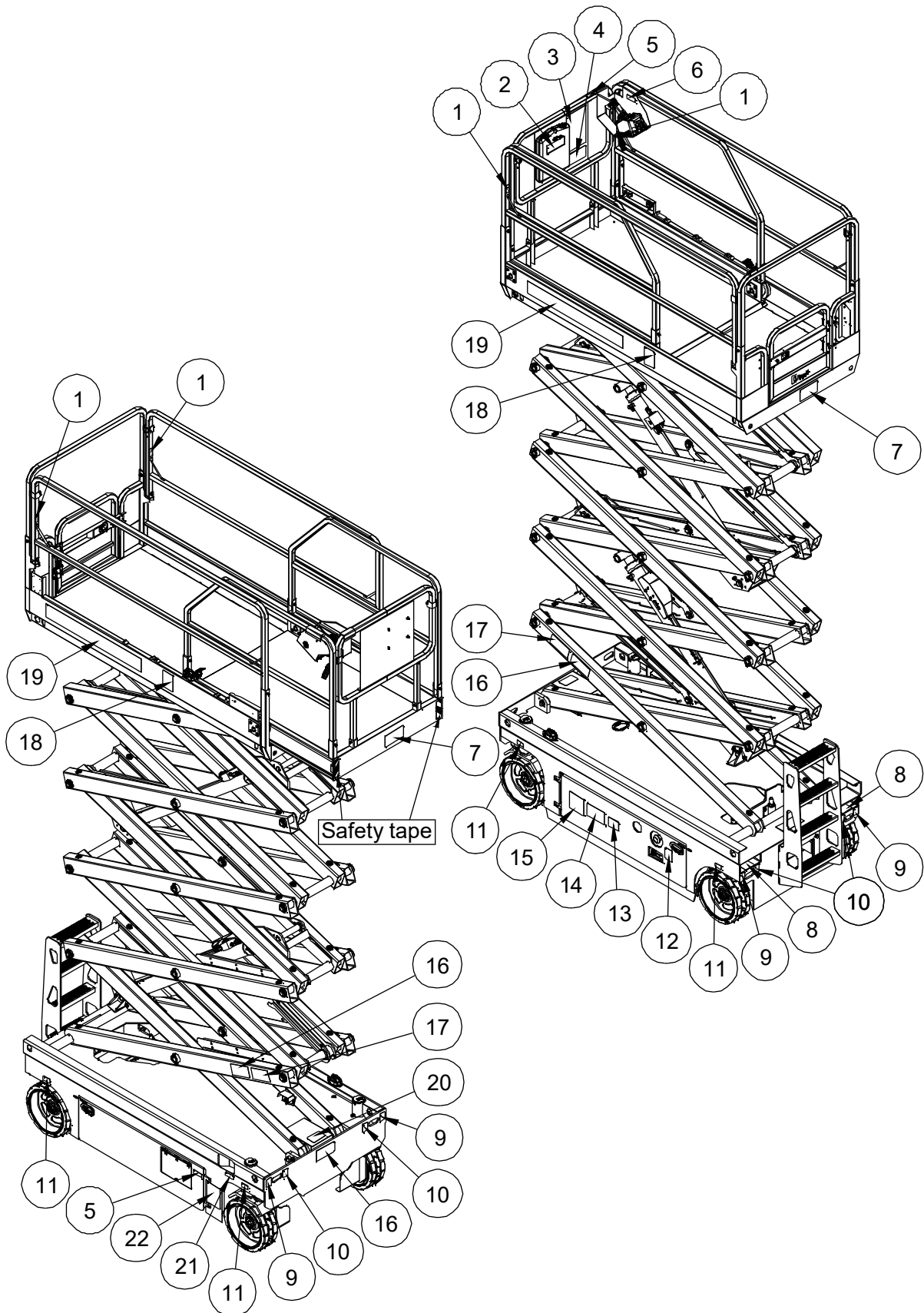

JCPT0808HA/AC~JCPT1614HA/AC

① 09440011



② 09340001



③ 09440037



④ 09440003



⑧ 09310001



⑤ 09340005

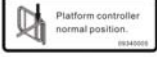

⑥ 09340003

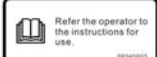

⑦ 09440027

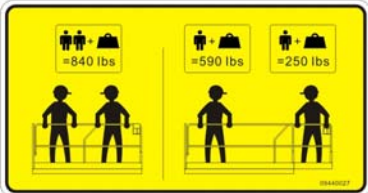

⑨ 09310003



⑩ 09310002



⑪ 09310021



⑪ 09310026



⑦ 09440029

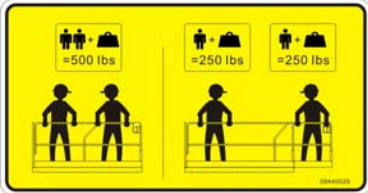

⑪ 09310023

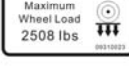

⑫ 09310006

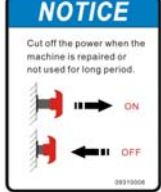

⑦ 09440031

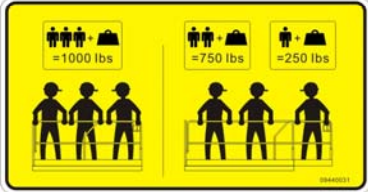

⑪ 09310020



⑪ 09310025

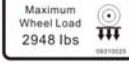

⑦ 09440035

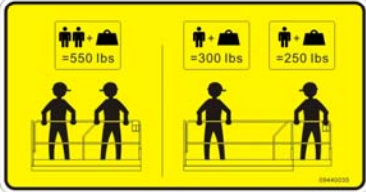

⑬ 09410007



⑦ 09440033



⑬ 09410009



⑬ 09410011



Decals

JCPT0808HA/AC~JCPT1614HA/AC

15 09410001



14 09410129



18 09440019



19 09640124

JCPT0808HA

19 09640125

JCPT0808AC

19 09640126

JCPT1008HA

19 09640127

JCPT1008AC

19 09640128

JCPT1012HA

19 09640129

JCPT1012AC

19 09640130

JCPT1212HA

19 09640131

JCPT1212AC

19 09640132

JCPT1412HA

19 09640133

JCPT1412AC

19 09640116

JCPT1614HA

19 09640117

JCPT1614AC

16 09430003



18 09440021



17 09430001



18 09440023



18 09440025



20 09410005



22 09410013



21 09310004



Specifications

Model: JCPT0807HA

| | | | | | |
|---|-----------------------------|--------|--|------------|-----------------------------------|
| Height, working maximum | 25.6 ft | 7.8 m | System voltage | 24 V | |
| Height, platform maximum | 19 ft | 5.8 m | Tire size | 12.7×4 in | Φ323×100 mm |
| Height, stowed maximum Rails up | 84.6 in | 2.15 m | Airborne noise emissions Maximum sound level at normal operating workstations (A-weighted) | <70 dB | |
| Height, stowed maximum Rails folded | 72.0 in | 1.83 m | Vibration value does not exceed 2.5m/s ² | | |
| Width | 29.9 in | 0.76 m | Maximum slope rating, Stowed position | 25% (14°) | |
| Length, platform retracted | 73.2 in | 1.86 m | Maximum side slope rating, Stowed position | 3° | |
| Length, platform extended | 108.7 in | 2.76 m | Note: Slope rating is subject to ground conditions and adequate traction. | | |
| Platform dimensions (length × width) | 65.7×29.1 in 1.67×0.74 m | | Warning slope | X-2°, Y-3° | |
| Platform extension length | 35.4 in | 0.9 m | Drive speeds | | |
| Maximum load capacity | 500 lbs | 227 kg | Stowed, maximum | 2.5mph | 4.0 km/h |
| Wheelbase | 53.5 in | 1.36 m | Platform raised, maximum | 0.36 mph | 0.6 km/h |
| Turning radius (outside) | 64.6 in | 1.64 m | Floor loading information | | |
| Turning radius (inside) | 0 in | 0 m | Tire load, maximum | 1462lbs | 710kg |
| Ground clearance | 3.3 in | 8.3 cm | Tire contact pressure | 148 psi | 10.4kg/cm ² 1019kPa |
| Ground clearance Pothole guards deployed | 0.6 in | 1.6 cm | Occupied floor pressure | 282 psf | 1373kg/m ² 13.5kPa |
| Weight Machine weights vary with option configurations | (See Serial Label) | | Note: Floor loading information is approximate and does not incorporate different option configurations. It should be used only with adequate safety factors. | | |
| Controls | Proportional | | Continuous improvement of our products is a DINGLI policy. Product specifications are subject to change without notice or obligation. | | |
| AC outlet in platform | Standard | | | | |
| Maximum hydraulic pressure (functions) | 2609 psi 180 bar | | | | |

Specifications

Model: JCPT0808HA

| | | | | | |
|---|-----------------------------|--------|--|---------------------|---------------------------------------|
| Height, working maximum | 26.2 ft | 8 m | System voltage | 24 V | |
| Height, platform maximum | 19.7 ft | 6 m | Tire size | 15×5 in | Φ381×127 mm |
| Height, stowed maximum Rails up | 87.8 in | 2.23 m | Airborne noise emissions Maximum sound level at normal operating workstations (A-weighted) | <70 dB | |
| Height, stowed maximum Rails folded | 73.6 in | 1.87 m | Vibration value does not exceed | 2.5m/s ² | |
| Width | 32.7 in | 0.83 m | Maximum slope rating, Stowed position | 25% (14°) | |
| Length, platform retracted | 97.6 in | 2.48 m | Maximum side slope rating, Stowed position | 5° | |
| Length, platform extended | 133.1 in | 3.38 m | Note: Slope rating is subject to ground conditions and adequate traction. | | |
| Platform dimensions (length × width) | 89.4×31.9 in 2.27×0.81 m | | Warning slope | X-2°,Y-3° | |
| Platform extension length | 35.4 in | 0.9 m | Drive speeds | | |
| Maximum load capacity | 840 lbs | 380 kg | Stowed, maximum | 2.2 mph | 3.5 km/h |
| Wheelbase | 73.6 in | 1.87 m | Platform raised, maximum | 0.5 mph | 0.8 km/h |
| Turning radius (outside) | 82.7 in | 2.1 m | Floor loading information | | |
| Turning radius (inside) | 0 in | 0 m | Tire load, maximum | 2118 lbs | 960 kg |
| Ground clearance | 3.9 in | 10 cm | Tire contact pressure | 152 psi | 10.6 kg/cm ² 1042.8 kPa |
| Ground clearance Pothole guards deployed | 0.7 in | 1.9 cm | Occupied floor pressure | 264 psf | 1284.6 kg/m ² 12.6 kPa |
| Weight Machine weights vary with option configurations | (See Serial Label) | | Note: Floor loading information is approximate and does not incorporate different option configurations. It should be used only with adequate safety factors. | | |
| Controls | Proportional | | Continuous improvement of our products is a DINGLI policy. Product specifications are subject to change without notice or obligation. | | |
| AC outlet in platform | Standard | | | | |
| Maximum hydraulic pressure (functions) | 3478 psi 240 bar | | | | |

Specifications**Model: JCPT1008HA**

| | | | | | |
|---|-----------------------------|--------|--|---------------------|---------------------------------------|
| Height, working maximum | 32.8 ft | 10 m | System voltage | 24 V | |
| Height, platform maximum | 26.2 ft | 8 m | Tire size | 15×5 in | Φ381×127 mm |
| Height, stowed maximum Rails up | 92.9 in | 2.36 m | Airborne noise emissions Maximum sound level at normal operating workstations (A-weighted) | <70 dB | |
| Height, stowed maximum Rails folded | 78.7 in | 2.00 m | Vibration value does not exceed | 2.5m/s ² | |
| Width | 32.7 in | 0.83 m | Maximum slope rating, Stowed position | 25% (14°) | |
| Length, platform retracted | 97.6 in | 2.48 m | Maximum side slope rating, Stowed position | 5° | |
| Length, platform extended | 133.1 in | 3.38 m | Note: Slope rating is subject to ground conditions and adequate traction. | | |
| Platform dimensions (length × width) | 89.4×31.9 in 2.27×0.81 m | | Warning slope | X-2°,Y-3° | |
| Platform extension length | 35.4 in | 0.9 m | Drive speeds | | |
| Maximum load capacity | 500 lbs | 227 kg | Stowed, maximum | 2.2 mph | 3.5 km/h |
| Wheelbase | 73.6 in | 1.87 m | Platform raised, maximum | 0.5 mph | 0.8 km/h |
| Turning radius (outside) | 82.7 in | 2.1 m | Floor loading information | | |
| Turning radius (inside) | 0 in | 0 m | Tire load, maximum | 2112 lbs | 960 kg |
| Ground clearance | 3.9 in | 10 cm | Tire contact pressure | 152 psi | 10.7 kg/cm ² 1043.7 kPa |
| Ground clearance Pothole guards deployed | 0.7 in | 1.9 cm | Occupied floor pressure | 264 psf | 1285.7 kg/m ² 12.6 kPa |
| Weight Machine weights vary with option configurations | (See Serial Label) | | Note: Floor loading information is approximate and does not incorporate different option configurations. It should be used only with adequate safety factors. | | |
| Controls | Proportional | | Continuous improvement of our products is a DINGLI policy. Product specifications are subject to change without notice or obligation. | | |
| AC outlet in platform | Standard | | | | |
| Maximum hydraulic pressure (functions) | 3478 psi 240 bar | | | | |

Specifications

Model: JCPT1012HA

| | | | | | |
|---|-----------------------------|--------|--|---------------------|---------------------------------------|
| Height, working maximum | 32.8 ft | 10 m | System voltage | 24 V | |
| Height, platform maximum | 26.2 ft | 8 m | Tire size | 15×5 in | Φ381×127 mm |
| Height, stowed maximum Rails up | 92.9 in | 2.36 m | Airborne noise emissions Maximum sound level at normal operating workstations (A-weighted) | <70 dB | |
| Height, stowed maximum Rails folded | 72.0 in | 1.83 m | Vibration value does not exceed | 2.5m/s ² | |
| Width | 45.3 in | 1.15 m | Maximum slope rating, Stowed position | 25% (14°) | |
| Length, platform retracted | 97.6 in | 2.48 m | Maximum side slope rating, Stowed position | 5° | |
| Length, platform extended | 133.1 in | 3.38 m | Note: Slope rating is subject to ground conditions and adequate traction. | | |
| Platform dimensions (length × width) | 89.4×44.1 in 2.27×1.12 m | | Warning slope | X-2°,Y-3° | |
| Platform extension length | 35.4 in | 0.9 m | Drive speeds | | |
| Maximum load capacity | 1000 lbs | 454 kg | Stowed, maximum | 2.2 mph | 3.5 km/h |
| Wheelbase | 73.6 in | 1.87 m | Platform raised, maximum | 0.5 mph | 0.8 km/h |
| Turning radius (outside) | 86.6 in | 2.2 m | Floor loading information | | |
| Turning radius (inside) | 0 in | 0 m | Tire load, maximum | 2376 lbs | 1080 kg |
| Ground clearance | 3.9 in | 10 cm | Tire contact pressure | 150 psi | 10.5 kg/cm ² 1029.8 kPa |
| Ground clearance Pothole guards deployed | 0.7 in | 1.9 cm | Occupied floor pressure | 210 psf | 1022.4 kg/m ² 10.0 kPa |
| Weight Machine weights vary with option configurations | (See Serial Label) | | Note: Floor loading information is approximate and does not incorporate different option configurations. It should be used only with adequate safety factors. | | |
| Controls | Proportional | | Continuous improvement of our products is a DINGLI policy. Product specifications are subject to change without notice or obligation. | | |
| AC outlet in platform | Standard | | | | |
| Maximum hydraulic pressure (functions) | 3478 psi 240 bar | | | | |

Specifications**Model: JCPT1212HA**

| | | | | | |
|---|---------------------|-------------|--|---------------------|---------------------------------------|
| Height, working maximum | 39.4 ft | 12 m | System voltage | 24 V | |
| Height, platform maximum | 32.8 ft | 10 m | Tire size | 15×5 in | Φ381×127 mm |
| Height, stowed maximum Rails up | 98.0 in | 2.49 m | Airborne noise emissions Maximum sound level at normal operating workstations (A-weighted) | <70 dB | |
| Height, stowed maximum Rails folded | 77.1 in | 1.96 m | Vibration value does not exceed | 2.5m/s ² | |
| Width | 45.3 in | 1.15 m | Maximum slope rating, Stowed position | 25% (14°) | |
| Length, platform retracted | 97.6 in | 2.48 m | Maximum side slope rating, Stowed position | 5° | |
| Length, platform extended | 133.1 in | 3.38 m | Note: Slope rating is subject to ground conditions and adequate traction. | | |
| Platform dimensions (length × width) | 89.4×44.1 in | 2.27×1.12 m | Warning slope | X-2°,Y-3° | |
| Platform extension length | 35.4 in | 0.9 m | Drive speeds | | |
| Maximum load capacity | 700 lbs | 318 kg | Stowed, maximum | 2.2 mph | 3.5 km/h |
| Wheelbase | 73.6 in | 1.87 m | Platform raised, maximum | 0.5 mph | 0.8 km/h |
| Turning radius (outside) | 86.6 in | 2.2 m | Floor loading information | | |
| Turning radius (inside) | 0 in | 0 m | Tire load, maximum | 2515 lbs | 1140 kg |
| Ground clearance | 3.9 in | 10 cm | Tire contact pressure | 159 psi | 11.1 kg/cm ² 1091.1 kPa |
| Ground clearance Pothole guards deployed | 0.7 in | 1.9 cm | Occupied floor pressure | 222 psf | 1083.3 kg/m ² 10.6 kPa |
| Weight Machine weights vary with option configurations | (See Serial Label) | | Note: Floor loading information is approximate and does not incorporate different option configurations. It should be used only with adequate safety factors. | | |
| Controls | Proportional | | Continuous improvement of our products is a DINGLI policy. Product specifications are subject to change without notice or obligation. | | |
| AC outlet in platform | Standard | | | | |
| Maximum hydraulic pressure (functions) | 3478 psi 240 bar | | | | |

Specifications

Model: JCPT1412HA

| | | | | | |
|---|-----------------------------|--------|--|---------------------|---------------------------------------|
| Height, working maximum | 45.3 ft | 13.8 m | System voltage | 24 V | |
| Height, platform maximum | 38.7 ft | 11.8 m | Tire size | 15×5 in | Φ381×127 mm |
| Height, stowed maximum Rails up | 103.1 in | 2.62 m | Airborne noise emissions Maximum sound level at normal operating workstations (A-weighted) | <70 dB | |
| Height, stowed maximum Rails folded | 82.3 in | 2.09 m | Vibration value does not exceed | 2.5m/s ² | |
| Width | 46.8 in | 1.19 m | Maximum slope rating, Stowed position | 25% (14°) | |
| Length, platform retracted | 97.6 in | 2.48 m | Maximum side slope rating, Stowed position | 5° | |
| Length, platform extended | 133.1 in | 3.38 m | Note: Slope rating is subject to ground conditions and adequate traction. | | |
| Platform dimensions (length × width) | 89.4×44.1 in 2.27×1.12 m | | Warning slope | X-2°,Y-3° | |
| Platform extension length | 35.4 in | 0.9 m | Drive speeds | | |
| Maximum load capacity | 550 lbs | 250 kg | Stowed, maximum | 2.2 mph | 3.5 km/h |
| Wheelbase | 73.6 in | 1.87 m | Platform raised, maximum | 0.5 mph | 0.8 km/h |
| Turning radius (outside) | 86.6 in | 2.2 m | Floor loading information | | |
| Turning radius (inside) | 0 in | 0 m | Tire load, maximum | 2948 lbs | 1340 kg |
| Ground clearance | 3.9 in | 10 cm | Tire contact pressure | 165 psi | 11.6 kg/cm ² 1135.2 kPa |
| Ground clearance Pothole guards deployed | 0.7 in | 1.9 cm | Occupied floor pressure | 252 psf | 1225.3 kg/m ² 12.0 kPa |
| Weight Machine weights vary with option configurations | (See Serial Label) | | Note: Floor loading information is approximate and does not incorporate different option configurations. It should be used only with adequate safety factors. | | |
| Controls | Proportional | | Continuous improvement of our products is a DINGLI policy. Product specifications are subject to change without notice or obligation. | | |
| AC outlet in platform | Standard | | | | |
| Maximum hydraulic pressure (functions) | 3478 psi 240 bar | | | | |

Specifications**Model: JCPT1614HA**

| | | | | | |
|---|---------------------|-------------|--|---------------------|---------------------------------------|
| Height, working maximum | 51.5 ft | 15.7 m | System voltage | 24 V | |
| Height, platform maximum | 44.9 ft | 13.7 m | Tire size | 15×5 in | Φ381×127 mm |
| Height, stowed maximum Rails up | 103.1 in | 2.62 m | Airborne noise emissions Maximum sound level at normal operating workstations (A-weighted) | <70 dB | |
| Height, stowed maximum Rails folded | 82.3 in | 2.09 m | Vibration value does not exceed | 2.5m/s ² | |
| Width | 54.7 in | 1.39 m | Maximum slope rating, Stowed position | 25% (14°) | |
| Length, platform retracted | 111.8 in | 2.84 m | Maximum side slope rating, Stowed position | 5° | |
| Length, platform extended | 147.2 in | 3.74 m | Note: Slope rating is subject to ground conditions and adequate traction. | | |
| Platform dimensions (length × width) | 103.9×44.1 in | 2.64×1.12 m | Warning slope | X-2°,Y-3° | |
| Platform extension length | 35.4 in | 0.9 m | Drive speeds | | |
| Maximum load capacity | 500 lbs | 227 kg | Stowed, maximum | 2.2 mph | 3.5 km/h |
| Wheelbase | 87.4 in | 2.22 m | Platform raised, maximum | 0.5 mph | 0.8 km/h |
| Turning radius (outside) | 106.3 in | 2.7 m | Floor loading information | | |
| Turning radius (inside) | 0 in | 0 m | Tire load, maximum | 3124 lbs | 1420 kg |
| Ground clearance | 3.9 in | 10 cm | Tire contact pressure | 175 psi | 12.3 kg/cm ² 1202.8 kPa |
| Ground clearance Pothole guards deployed | 0.7 in | 1.9 cm | Occupied floor pressure | 196 psf | 955.7 kg/m ² 9.4 kPa |
| Weight Machine weights vary with option configurations | (See Serial Label) | | Note: Floor loading information is approximate and does not incorporate different option configurations. It should be used only with adequate safety factors. | | |
| Controls | Proportional | | Continuous improvement of our products is a DINGLI policy. Product specifications are subject to change without notice or obligation. | | |
| AC outlet in platform | Standard | | | | |
| Maximum hydraulic pressure (functions) | 3478 psi 240 bar | | | | |

Specifications

Model: JCPT0807AC

| | | | | | |
|---|---------------------|-------------|--|---------------------|-----------------------------------|
| Height, working maximum | 25.6 ft | 7.8 m | System voltage | 24 V | |
| Height, platform maximum | 19 ft | 5.8 m | Tire size | 12.7×4 in | Φ323×100 mm |
| Height, stowed maximum Rails up | 84.6 in | 2.15 m | Airborne noise emissions Maximum sound level at normal operating workstations (A-weighted) | <70 dB | |
| Height, stowed maximum Rails folded | 72.0 in | 1.83 m | Vibration value does not exceed | 2.5m/s ² | |
| Width | 29.9 in | 0.76 m | Maximum slope rating, Stowed position | 25% (14°) | |
| Length, platform retracted | 73.2 in | 1.86 m | Maximum side slope rating, Stowed position | 3° | |
| Length, platform extended | 108.7 in | 2.76 m | Note: Slope rating is subject to ground conditions and adequate traction. | | |
| Platform dimensions (length × width) | 65.7×29.1 in | 1.67×0.74 m | Warning slope | X-2°,Y-3° | |
| Platform extension length | 35.4 in | 0.9 m | Drive speeds | | |
| Maximum load capacity | 500 lbs | 227 kg | Stowed, maximum | 2.8 mph | 4.5 km/h |
| Wheelbase | 53.5 in | 1.36 m | Platform raised, maximum | 0.36 mph | 0.6 km/h |
| Turning radius (outside) | 64.6 in | 1.64 m | Floor loading information | | |
| Turning radius (inside) | 0 in | 0 m | Tire load, maximum | 1462lbs | 710kg |
| Ground clearance | 3.56 in | 9.0 cm | Tire contact pressure | 148 psi | 10.4kg/cm ² 1019kPa |
| Ground clearance Pothole guards deployed | 0.6 in | 1.6 cm | Occupied floor pressure | 282 psf | 1373kg/m ² 13.5kPa |
| Weight Machine weights vary with option configurations | (See Serial Label) | | Note: Floor loading information is approximate and does not incorporate different option configurations. It should be used only with adequate safety factors. | | |
| Controls | Proportional | | Continuous improvement of our products is a DINGLI policy. Product specifications are subject to change without notice or obligation. | | |
| AC outlet in platform | Standard | | | | |
| Maximum hydraulic pressure (functions) | 2609 psi 180 bar | | | | |

Specifications**Model: JCPT0808AC**

| | | | | | |
|---|-----------------------------|--------|--|---------------------|---------------------------------------|
| Height, working maximum | 26.2 ft | 8 m | System voltage | 24 V | |
| Height, platform maximum | 19.7 ft | 6 m | Tire size | 15×5 in | Φ381×127 mm |
| Height, stowed maximum Rails up | 87.8 in | 2.23 m | Airborne noise emissions Maximum sound level at normal operating workstations (A-weighted) | <70 dB | |
| Height, stowed maximum Rails folded | 73.6 in | 1.87 m | Vibration value does not exceed | 2.5m/s ² | |
| Width | 32.7 in | 0.83 m | Maximum slope rating, Stowed position | 25% (14°) | |
| Length, platform retracted | 97.6 in | 2.48 m | Maximum side slope rating, Stowed position | 5° | |
| Length, platform extended | 133.1 in | 3.38 m | Note: Slope rating is subject to ground conditions and adequate traction. | | |
| Platform dimensions (length × width) | 89.4×31.9 in 2.27×0.81 m | | Warning slope | X-2°,Y-3° | |
| Platform extension length | 35.4 in | 0.9 m | Drive speeds | | |
| Maximum load capacity | 840 lbs | 380 kg | Stowed, maximum | 3.1mph | 5.0 km/h |
| Wheelbase | 73.6 in | 1.87 m | Platform raised, maximum | 0.5 mph | 0.8 km/h |
| Turning radius (outside) | 82.7 in | 2.1 m | Floor loading information | | |
| Turning radius (inside) | 0 in | 0 m | Tire load, maximum | 2112 lbs | 960 kg |
| Ground clearance | 3.9 in | 10 cm | Tire contact pressure | 154 psi | 10.8 kg/cm ² 1060.5 kPa |
| Ground clearance Pothole guards deployed | 0.7 in | 1.9 cm | Occupied floor pressure | 268 psf | 1306.4 kg/m ² 12.8 kPa |
| Weight Machine weights vary with option configurations | (See Serial Label) | | Note: Floor loading information is approximate and does not incorporate different option configurations. It should be used only with adequate safety factors. | | |
| Controls | Proportional | | Continuous improvement of our products is a DINGLI policy. Product specifications are subject to change without notice or obligation. | | |
| AC outlet in platform | Standard | | | | |
| Maximum hydraulic pressure (functions) | 3478 psi 240 bar | | | | |

Specifications

Model: JCPT1008AC

| | | | | | |
|---|-----------------------------|--------|--|---------------------|---------------------------------------|
| Height, working maximum | 32.8 ft | 10 m | System voltage | 24 V | |
| Height, platform maximum | 26.2 ft | 8 m | Tire size | 15×5 in | Φ381×127 mm |
| Height, stowed maximum Rails up | 92.9 in | 2.36 m | Airborne noise emissions Maximum sound level at normal operating workstations (A-weighted) | <70 dB | |
| Height, stowed maximum Rails folded | 78.7 in | 2.00 m | Vibration value does not exceed | 2.5m/s ² | |
| Width | 32.7 in | 0.83 m | Maximum slope rating, Stowed position | 25% (14°) | |
| Length, platform retracted | 97.6 in | 2.48 m | Maximum side slope rating, Stowed position | 5° | |
| Length, platform extended | 133.1 in | 3.38 m | Note: Slope rating is subject to ground conditions and adequate traction. | | |
| Platform dimensions (length × width) | 89.4×31.9 in 2.27×0.81 m | | Warning slope | X-2°,Y-3° | |
| Platform extension length | 35.4 in | 0.9 m | Drive speeds | | |
| Maximum load capacity | 500 lbs | 227 kg | Stowed, maximum | 3.1 mph | 5.0 km/h |
| Wheelbase | 73.6 in | 1.87 m | Platform raised, maximum | 0.5 mph | 0.8 km/h |
| Turning radius (outside) | 82.7 in | 2.1 m | Floor loading information | | |
| Turning radius (inside) | 0 in | 0 m | Tire load, maximum | 2112 lbs | 960 kg |
| Ground clearance | 3.9 in | 10 cm | Tire contact pressure | 154 psi | 10.8 kg/cm ² 1061.4 kPa |
| Ground clearance Pothole guards deployed | 0.7 in | 1.9 cm | Occupied floor pressure | 268 psf | 1307.5 kg/m ² 12.8 kPa |
| Weight Machine weights vary with option configurations | (See Serial Label) | | Note: Floor loading information is approximate and does not incorporate different option configurations. It should be used only with adequate safety factors. | | |
| Controls | Proportional | | Continuous improvement of our products is a DINGLI policy. Product specifications are subject to change without notice or obligation. | | |
| AC outlet in platform | Standard | | | | |
| Maximum hydraulic pressure (functions) | 3478 psi 240 bar | | | | |

Specifications

Model: JCPT1012AC

| | | | | | |
|---|---------------------|-------------|--|---------------------|---------------------------------------|
| Height, working maximum | 32.8 ft | 10 m | System voltage | 24 V | |
| Height, platform maximum | 26.2 ft | 8 m | Tire size | 15×5 in | Φ381×127 mm |
| Height, stowed maximum Rails up | 92.9 in | 2.36 m | Airborne noise emissions Maximum sound level at normal operating workstations (A-weighted) | <70 dB | |
| Height, stowed maximum Rails folded | 72.0 in | 1.83 m | Vibration value does not exceed | 2.5m/s ² | |
| Width | 45.3 in | 1.15 m | Maximum slope rating, Stowed position | 25% (14°) | |
| Length, platform retracted | 97.6 in | 2.48 m | Maximum side slope rating, Stowed position | 5° | |
| Length, platform extended | 133.1 in | 3.38 m | Note: Slope rating is subject to ground conditions and adequate traction. | | |
| Platform dimensions (length × width) | 89.4×44.1 in | 2.27×1.12 m | Warning slope | X-2°,Y-3° | |
| Platform extension length | 35.4 in | 0.9 m | Drive speeds | | |
| Maximum load capacity | 1000 lbs | 454 kg | Stowed, maximum | 3.1 mph | 5.0 km/h |
| Wheelbase | 73.6 in | 1.87 m | Platform raised, maximum | 0.5 mph | 0.8 km/h |
| Turning radius (outside) | 86.6 in | 2.2 m | Floor loading information | | |
| Turning radius (inside) | 0 in | 0 m | Tire load, maximum | 2376 lbs | 1080 kg |
| Ground clearance | 3.9 in | 10 cm | Tire contact pressure | 152 psi | 10.7 kg/cm ² 1045.2 kPa |
| Ground clearance Pothole guards deployed | 0.7 in | 1.9 cm | Occupied floor pressure | 213 psf | 1037.7 kg/m ² 10.2 kPa |
| Weight Machine weights vary with option configurations | (See Serial Label) | | Note: Floor loading information is approximate and does not incorporate different option configurations. It should be used only with adequate safety factors. | | |
| Controls | Proportional | | Continuous improvement of our products is a DINGLI policy. Product specifications are subject to change without notice or obligation. | | |
| AC outlet in platform | Standard | | | | |
| Maximum hydraulic pressure (functions) | 3478 psi 240 bar | | | | |

Specifications

Model: JCPT1212AC

| | | | | | |
|---|-----------------------------|--------|--|---------------------|---------------------------------------|
| Height, working maximum | 39.4 ft | 12 m | System voltage | 24 V | |
| Height, platform maximum | 32.8 ft | 10 m | Tire size | 15×5 in | Φ381×127 mm |
| Height, stowed maximum Rails up | 98.0 in | 2.49 m | Airborne noise emissions Maximum sound level at normal operating workstations (A-weighted) | <70 dB | |
| Height, stowed maximum Rails folded | 77.1 in | 1.96 m | Vibration value does not exceed | 2.5m/s ² | |
| Width | 45.3 in | 1.15 m | Maximum slope rating, Stowed position | 25% (14°) | |
| Length, platform retracted | 97.6 in | 2.48 m | Maximum side slope rating, Stowed position | 5° | |
| Length, platform extended | 133.1 in | 3.38 m | Note: Slope rating is subject to ground conditions and adequate traction. | | |
| Platform dimensions (length × width) | 89.4×44.1 in 2.27×1.12 m | | Warning slope | X-2°,Y-3° | |
| Platform extension length | 35.4 in | 0.9 m | Drive speeds | | |
| Maximum load capacity | 700 lbs | 318 kg | Stowed, maximum | 3.1 mph | 5.0 km/h |
| Wheelbase | 73.6 in | 1.87 m | Platform raised, maximum | 0.5 mph | 0.8 km/h |
| Turning radius (outside) | 86.6 in | 2.2 m | Floor loading information | | |
| Turning radius (inside) | 0 in | 0 m | Tire load, maximum | 2508 lbs | 1140 kg |
| Ground clearance | 3.9 in | 10 cm | Tire contact pressure | 160 psi | 11.2 kg/cm ² 1098.8 kPa |
| Ground clearance Pothole guards deployed | 0.7 in | 1.9 cm | Occupied floor pressure | 224 psf | 1091.0 kg/m ² 10.7 kPa |
| Weight Machine weights vary with option configurations | (See Serial Label) | | Note: Floor loading information is approximate and does not incorporate different option configurations. It should be used only with adequate safety factors. | | |
| Controls | Proportional | | Continuous improvement of our products is a DINGLI policy. Product specifications are subject to change without notice or obligation. | | |
| AC outlet in platform | Standard | | | | |
| Maximum hydraulic pressure (functions) | 3478 psi 240 bar | | | | |

Specifications**Model: JCPT1412AC**

| | | | | | |
|---|-----------------------------|--------|--|---------------------|---------------------------------------|
| Height, working maximum | 45.3 ft | 13.8 m | System voltage | 24 V | |
| Height, platform maximum | 38.7 ft | 11.8 m | Tire size | 15×5 in | Φ381×127 mm |
| Height, stowed maximum Rails up | 103.1 in | 2.62 m | Airborne noise emissions Maximum sound level at normal operating workstations (A-weighted) | <70 dB | |
| Height, stowed maximum Rails folded | 82.3 in | 2.09 m | Vibration value does not exceed | 2.5m/s ² | |
| Width | 46.8 in | 1.19 m | Maximum slope rating, Stowed position | 25% (14°) | |
| Length, platform retracted | 97.6 in | 2.48 m | Maximum side slope rating, Stowed position | 5° | |
| Length, platform extended | 133.1 in | 3.38 m | Note: Slope rating is subject to ground conditions and adequate traction. | | |
| Platform dimensions (length × width) | 89.4×44.1 in 2.27×1.12 m | | Warning slope | X-2°,Y-3° | |
| Platform extension length | 35.4 in | 0.9 m | Drive speeds | | |
| Maximum load capacity | 550 lbs | 250 kg | Stowed, maximum | 3.1 mph | 5.0 km/h |
| Wheelbase | 73.6 in | 1.87 m | Platform raised, maximum | 0.5 mph | 0.8 km/h |
| Turning radius (outside) | 86.6 in | 2.2 m | Floor loading information | | |
| Turning radius (inside) | 0 in | 0 m | Tire load, maximum | 2948 lbs | 1340 kg |
| Ground clearance | 3.9 in | 10 cm | Tire contact pressure | 167 psi | 11.7 kg/cm ² 1148.9 kPa |
| Ground clearance Pothole guards deployed | 0.7 in | 1.9 cm | Occupied floor pressure | 255 psf | 1240.1 kg/m ² 12.2 kPa |
| Weight Machine weights vary with option configurations | (See Serial Label) | | Note: Floor loading information is approximate and does not incorporate different option configurations. It should be used only with adequate safety factors. | | |
| Controls | Proportional | | Continuous improvement of our products is a DINGLI policy. Product specifications are subject to change without notice or obligation. | | |
| AC outlet in platform | Standard | | | | |
| Maximum hydraulic pressure (functions) | 3478 psi 240 bar | | | | |

Specifications

Model: JCPT1614AC

| | | | | | |
|---|---------------------|-------------|--|---------------------|---------------------------------------|
| Height, working maximum | 51.5 ft | 15.7 m | System voltage | 24 V | |
| Height, platform maximum | 44.9 ft | 13.7 m | Tire size | 15×5 in | Φ381×127 mm |
| Height, stowed maximum Rails up | 103.1 in | 2.62 m | Airborne noise emissions Maximum sound level at normal operating workstations (A-weighted) | <70 dB | |
| Height, stowed maximum Rails folded | 82.3 in | 2.09 m | Vibration value does not exceed | 2.5m/s ² | |
| Width | 54.7 in | 1.39 m | Maximum slope rating, Stowed position | 25% (14°) | |
| Length, platform retracted | 111.8 in | 2.84 m | Maximum side slope rating, Stowed position | 5° | |
| Length, platform extended | 147.2 in | 3.74 m | Note: Slope rating is subject to ground conditions and adequate traction. | | |
| Platform dimensions (length × width) | 103.9×44.1 in | 2.64×1.12 m | Warning slope | X-2°,Y-3° | |
| Platform extension length | 35.4 in | 0.9 m | Drive speeds | | |
| Maximum load capacity | 500 lbs | 227 kg | Stowed, maximum | 3.1mph | 5.0 km/h |
| Wheelbase | 87.4 in | 2.22 m | Platform raised, maximum | 0.5 mph | 0.8 km/h |
| Turning radius (outside) | 106.3 in | 2.7 m | Floor loading information | | |
| Turning radius (inside) | 0 in | 0 m | Tire load, maximum | 3124 lbs | 1420 kg |
| Ground clearance | 3.9 in | 10 cm | Tire contact pressure | 177 psi | 12.4 kg/cm ² 1216.5 kPa |
| Ground clearance Pothole guards deployed | 0.7 in | 1.9 cm | Occupied floor pressure | 199 psf | 966.6 kg/m ² 9.5 kPa |
| Weight Machine weights vary with option configurations | (See Serial Label) | | Note: Floor loading information is approximate and does not incorporate different option configurations. It should be used only with adequate safety factors. | | |
| Controls | Proportional | | Continuous improvement of our products is a DINGLI policy. Product specifications are subject to change without notice or obligation. | | |
| AC outlet in platform | Standard | | | | |
| Maximum hydraulic pressure (functions) | 3478 psi 240 bar | | | | |

Specifications**Battery Specifications****Lead-acid battery**

| | | | |
|---|------------|---|-------------|
| JCPT0807AC, JCPT0807HA, JCPT0808AC, JCPT0808HA, JCPT1008AC, JCPT1008HA, JCPT1012AC, JCPT1012HA | standard | JCPT1212AC, JCPT1212HA | optional |
| Voltage | 6VDC | Voltage | 6VDC |
| Type | 6TB170 | Type | T-125 Plus |
| Quantity | 4 | Quantity | 4 |
| Battery capacity, maximum | 170Ah | Battery capacity, maximum | 240Ah |
| Maintenance-free | Yes | Maintenance-free | No |
| JCPT0807AC, JCPT0807HA | optional | JCPT1412AC, JCPT1412HA, JCPT1614AC, JCPT1614HA | standard |
| Voltage | 12VDC | Voltage | 6VDC |
| Type | T-605 | Type | 6TB220 |
| Quantity | 4 | Quantity | 4 |
| Battery capacity, maximum | 210Ah | Battery capacity, maximum | 220Ah |
| Maintenance-free | No | Maintenance-free | Yes |
| JCPT0808AC, JCPT0808HA, JCPT1008AC, JCPT1008HA, JCPT1012AC, JCPT1012HA | optional | JCPT1412AC, JCPT1412HA, JCPT1614AC, JCPT1614HA | optional |
| Voltage | 6VDC | Voltage | 12VDC |
| Type | T-105 Plus | Type | T-1275 Plus |
| Quantity | 4 | Quantity | 4 |
| Battery capacity, maximum | 225Ah | Battery capacity, maximum | 150Ah |
| Maintenance-free | No | Maintenance-free | No |
| JCPT1212AC, JCPT1212HA | standard | | |
| Voltage | 6VDC | | |
| Type | 6TB220 | | |
| Quantity | 4 | | |
| Battery capacity, maximum | 220Ah | | |
| Maintenance-free | Yes | | |

Specifications

Lithium battery

| | |
|---|---------------|
| JCPT0807AC, JCPT0807HA, JCPT0808AC, JCPT0808HA, JCPT1008AC, JCPT1008HA, JCPT1012AC, JCPT1012HA | optional |
| Voltage | 24VDC |
| Type | TFL24-180-DL3 |
| Quantity | 1 |
| Battery capacity, maximum | 180AH |
| Maintenance-free | Yes |
| JCPT1212AC, JCPT1212HA, JCPT1412AC, JCPT1412HA, JCPT1614AC, JCPT1614HA | optional |
| Voltage | 24VDC |
| Type | TFL24-220-DL2 |
| Quantity | 1 |
| Battery capacity, maximum | 220AH |
| Maintenance-free | Yes |

Control Panel

Ground Control Panel

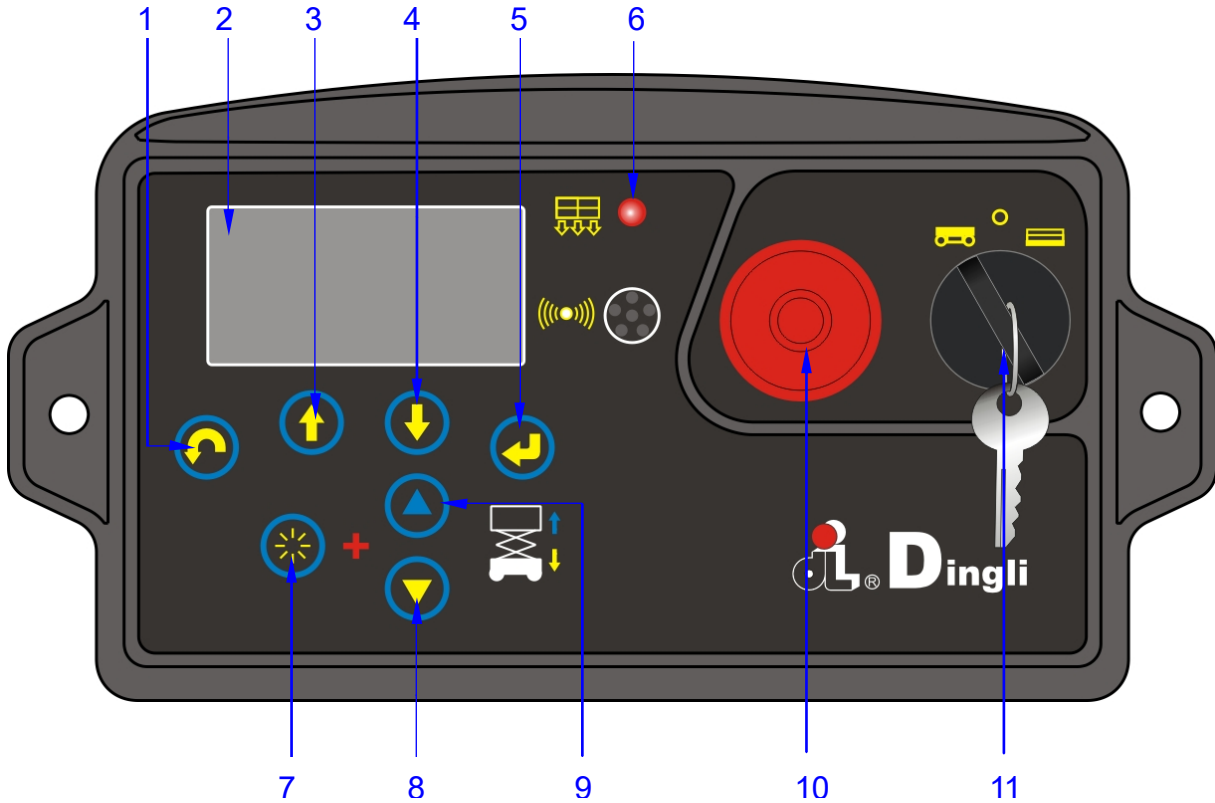

1 Menu escape button

2 LED readout screen

3 Menu up button

4 Menu down button

5 Menu enter button

6 Overload indicator light

7 Function enable button

8.. Platform down button

9 Platform up button

10 Red Emergency Stop button

Push in the red Emergency Stop button to the off position to stop all functions. Pull out the red Emergency Stop button to the on position to operate the machine.

11 Key switch

Turn the key switch to the platform position and the platform controls will operate. Turn the key switch to the off position and the machine will be off. Turn the key switch to the base position and the ground controls will operate.

Control Panel

Platform Control Panel

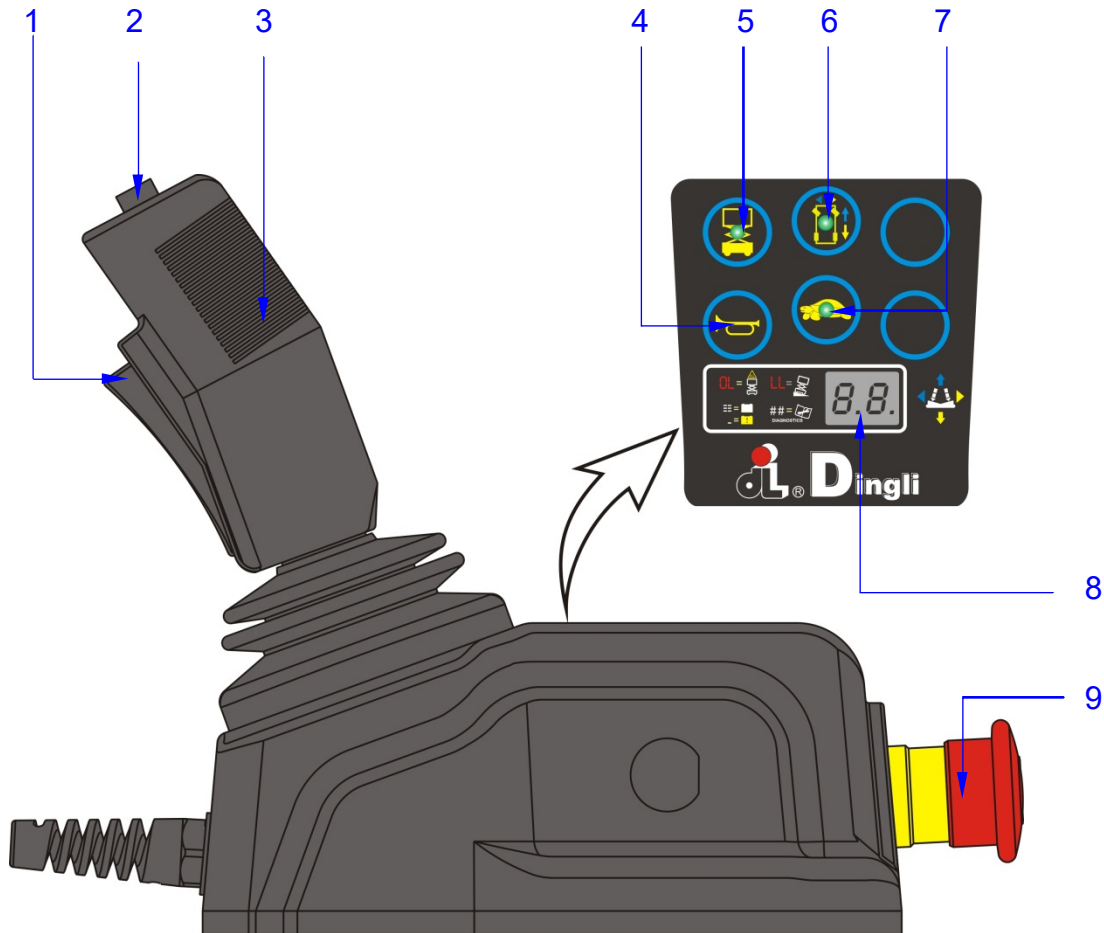

- | | | | |
|---|-----------------------------|---|------------------------------|
| 1 | Function enable switch | 6 | Drive function select button |
| 2 | Thumb rocker switch | 7 | Drive speed button |
| 3 | Proportional control handle | 8 | LED readout screen |
| 4 | Horn button | 9 | Red Emergency Stop button |
| 5 | Lift function select button | | |

Control Panel

Platform Control Panel

1 Function enable switch

Press and hold the function enable switch to enable the drive/lift function.

2 Thumb rocker switch

Press the thumb rocker switch in either direction to activate steer function.

3 Proportional control handle

Lift function: Press and hold the function enable switch to enable the lift function on the platform control handle. Move the control handle in the direction indicated by the blue arrow and the platform will raise. Move the control handle in the direction indicated by the yellow arrow and the platform will lower. The descent alarm should sound while the platform is lowering.

Drive function: Press and hold the function enable switch to enable the drive function on the platform control handle. Move the control handle in the direction indicated by the blue arrow on the control panel and the machine will move in the direction that the blue arrow points. Move the control handle in the direction indicated by the yellow arrow on the control panel and the machine will move in the direction that the yellow arrow points.

4 Horn Button

Push the horn button and the horn will sound. Release the horn button and the horn will stop.

5 Lift function select button

Press this button to activate the lift function.

6 Drive function select button

Press this button to activate the drive function.

7 Drive speed button

Press this button to activate the slow or fast drive function.

8 LED readout screen

Diagnostic readout and battery charge indicator.

9 Red Emergency Stop button

Push in the red Emergency Stop button to the off position to stop all functions. Pull out the red Emergency Stop button to the on position to operate the machine.

Pre-operation Inspection



Do Not Operate Unless:

You learn and practice the principles of safe machine operation contained in this operator's manual.

- 1 Avoid hazardous situations.
- 2 Always perform a pre-operation inspection.**

Know and understand the pre-operation inspection before going on to the next section.

- 3 Inspect the workplace.
- 4 Always perform function tests prior to use.
- 5 Only use the machine as it was intended.

Fundamentals

It is the responsibility of the operator to perform a pre-operation inspection and routine maintenance.

The pre-operation inspection is a visual inspection performed by the operator prior to each work shift. The inspection is designed to discover if anything is apparently wrong with a machine before the operator performs the function tests.

The pre-operation inspection also serves to determine if routine maintenance procedures are required. Only routine maintenance items specified in this manual may be performed by the operator.

Refer to the list on the next page and check each of the items.

If damage or any unauthorized variation from factory delivered condition is discovered, the machine must be tagged and removed from service.

Repairs to the machine may only be made by a qualified service technician, according to the manufacturer's specifications. After repairs are completed, the operator must perform a pre-operation inspection again before going on to the function tests.

Scheduled maintenance inspections shall be performed by qualified service technicians, according to the manufacturer's specifications and the requirements listed in this manual.

Pre-operation Inspection

Pre-operation Inspection

- Be sure that the operator's manual are complete, legible and in the storage container located in the platform.
- Be sure that all decals are legible and in place. See Decals section.
- Check for hydraulic oil leaks and proper oil level. Add oil if needed. See Maintenance section.
- Check for battery fluid leaks and proper fluid level. Add distilled water if needed. See Maintenance section.

Check the following components or areas for damage, improperly installed or missing parts and unauthorized modifications:

- Electrical components, wiring and electrical cables
- Hydraulic hoses, fittings, cylinders and manifolds
- Battery pack and connections
- Drive motors
- Wear pads
- Tires and wheels
- Ground strap
- Limit switches, alarms and horn
- Nuts, bolts and other fasteners
- Platform overload components
- Platform entry gate
- Beacon (if equipped)
- Safety arm
- Platform extension(s)
- Scissor pins and retaining fasteners
- Platform control joystick
- Brake release components
- Pothole guard

Check entire machine for:

- Cracks in welds or structural components
- Dents or damage to machine
- Be sure that all structural and other critical components are present and all associated fasteners and pins are in place and properly tightened
- Be sure side rails are installed and rail pins and bolts are fastened.
- Be sure that the chassis trays are closed and latched and the batteries are properly connected.

Note: If the platform must be raised to inspect the machine, make sure the safety arm is in place. See Operating Instructions section.

Workplace Inspection



Do Not Operate Unless:

You learn and practice the principles of safe machine operation contained in this operator's manual.

- 1 Avoid hazardous situations.
- 2 Always perform a pre-operation inspection.
- 3 Inspect the workplace.**

Know and understand the workplace inspection before going on to the next section.

- 4 Always perform function tests prior to use.
- 5 Only use the machine as it was intended.

Fundamentals

The workplace inspection helps the operator determine if the workplace is suitable for safe machine operation. It should be performed by the operator prior to moving the machine to the workplace.

It is the operator's responsibility to read and remember the workplace hazards, then watch for and avoid them while moving, setting up and operating the machine.

Workplace Inspection

Be aware of and avoid the following hazardous situations:

- Drop-offs or holes
- Bumps, floor obstructions or debris
- Sloped surfaces
- Unstable or slippery surfaces
- Overhead obstructions and high voltage conductors
- Hazardous locations
- Inadequate surface support to withstand all load forces imposed by the machine
- Wind and weather conditions
- The presence of unauthorized personnel
- Other possible unsafe conditions

Function Tests



Do Not Operate Unless:

You learn and practice the principles of safe machine operation contained in this operator's manual.

- 1 Avoid hazardous situations.
- 2 Always perform a pre-operation inspection.
- 3 Inspect the workplace.
- 4 **Always perform function tests prior to use.**

Know and understand the function tests before going on to the next section.

- 5 Only use the machine as it was intended.

Fundamentals

The function tests are designed to discover any malfunctions before the machine is put into service.

The operator must follow the step-by-step instructions to test all machine functions.

A malfunctioning machine must never be used. If malfunctions are discovered, the machine must be tagged and removed from service.

Repairs to the machine may only be made by a qualified service technician, according to the manufacturer's specifications.

After repairs are completed, the operator must perform a pre-operation inspection and function tests again before putting the machine into service.

Function Tests

- 1 Select a test area that is firm, level and free of obstruction.
- 2 Be sure the battery pack is connected.
- 3 Pull out the main power switch to "on" position.

At the Ground Controls

- 4 Pull out the platform and ground red Emergency Stop button to the on position.
- 5 Turn the key switch to ground control.
- 6 Observe the LED readout screen on the platform controls.

- ⊙ Result: The LED should look like the picture at right.



- 7 Observe the LED readout screen on the ECU window.

- ⊙ Result: The LED should look like the picture at right.



Test Emergency Stop

- 8 Push in the ground red Emergency Stop button to the off position.
- ⊙ Result: No functions should operate.
- 9 Pull out the red Emergency Stop button to the on position

Test Up/Down Functions

A buzzer with different sound frequency is controlled in central system. The descent alarm sounds at 60 beeps per minute. The alarm that goes off when the pothole guards have not deployed sounds at 180 beeps per minute. The alarm that goes off when the machine is not level sounds at 180 beeps per minute. An optional automotive-style horn is also available.

- 10 Do not press the function enable button.

- 11 Press the platform up or platform down button.

- ⊙ Result: No function should operate.

- 12 Do not press the platform up or platform down buttons.

- 13 Press the function enable button.

- ⊙ Result: No function should operate.

- 14 Press and hold the function enable button, and press the platform up button.

- ⊙ Result: The platform should raise.

- 15 Press and hold the function enable button, and press the platform down button.

- ⊙ Result: The platform should lower to end. The descent alarm should sound while the platform is lowering.

Test the Emergency Lowering

- 16 Activate the up function and raise the platform approximately 2 ft / 60 cm.

- 17 Pull the emergency lowering knob located on the ground controls side of the machine.

- ⊙ Result: The platform should lower. The descent alarm will not sound.

- 18 Turn the key switch to platform control.

At the Platform Controls

Test Emergency Stop

- 19 Push in the platform red Emergency Stop button to the off position.

- ⊙ Result: No functions should operate.

- 20 Pull out the red Emergency Stop button to the on position.

- ⊙ Result: The LED indicator light should come on.

Function Tests

Test the Horn

21 Push the horn button.

- ⦿ Result: The horn should sound.

Test Function Enable and Up/Down Functions

22 Do not hold the function enable switch on the control handle.

23 Slowly move the control handle in the direction indicated by the blue up arrow, then in the direction indicated by the yellow down arrow.

- ⦿ Result: No functions should operate.

24 Press the lift function select button.

25 Press and hold the function enable switch on the control handle.

26 Slowly move the control handle in the direction indicated by the blue up arrow.

- ⦿ Result: The platform should raise. The pothole guards should deploy.

27 Release the control handle.

- ⦿ Result: The platform should stop raising.

28 Press and hold the function enable switch. Slowly move the control handle in the direction indicated by the yellow down arrow.

- ⦿ Result: The platform should lower. The descent alarm should sound while the platform is lowering.

Test the Steering

Note: When performing the steer and drive function tests, stand in the platform facing the steer end of the machine.

29 Press the drive function select button. The indicator light should turn on.

30 Press and hold the function enable switch on the control handle.

31 Depress the thumb rocker switch on top of the control handle in the direction identified by the blue left arrow on the control panel.

- ⦿ Result: The steer wheels should turn in the direction that the blue left arrow points on the control panel.

32 Depress the thumb rocker switch in the direction identified by the yellow right arrow on the control panel.

- ⦿ Result: The steer wheels should turn in the direction that the yellow right arrow points on the control panel.

Test Drive and Braking

33 Press the drive function select button. The indicator light should turn on.

34 Press and hold the function enable switch on the control handle.

35 Slowly move the control handle in the direction indicated by the blue up arrow on the control panel until the machine begins to move, then return the handle to the center position.

- ⦿ Result: The machine should move in the direction that the blue up arrow points on the control panel, then come to an abrupt stop.

36 Press and hold the function enable switch on the control handle.

37 Slowly move the control handle in the direction indicated by the yellow down arrow on the control panel until the machine begins to move, then return the handle to the center position.

- ⦿ Result: The machine should move in the direction that the yellow down arrow points on the control panel, then come to an abrupt stop.

Note: The brakes must be able to hold the machine on any slope it is able to climb.

Function Tests

Test Limited Drive Speed

38 Press and hold the function enable switch. Raise the platform approximately 6.6ft / 2m from the ground.

⊙ Result: The pothole guards should deploy.

39 Press and hold the function enable switch on the control handle.

40 Slowly move the control handle to the full drive position.

⊙ Result: The maximum achievable drive speed with the platform raised should not exceed 0.72 ft per second / 22 cm/s.

⊖ Result: If the drive speed with the platform raised exceeds 0.72 ft per second / 22 cm/s., immediately tag and remove the machine from service.

Test the Tilt Sensor Operation

Note: Perform this test from the ground with the platform controller. Do not stand in the platform.

41 Fully lower the platform.

42 Place a 2.0×7.9 in / 5×20 cm or similar piece of wood under both wheels on one side and drive the machine up onto them.

43 Raise the platform approximately 2m from the ground.

⊙ Result: The platform should stop and the tilt alarm will sound at 180 beeps per minute. The platform controls LED readout should display LL.

44 Press the drive function select button.

45 Press and hold the function enable switch on the control handle.

46 Move the control handle in the direction indicated by the blue up arrow, then move the control handle in the direction indicated by the yellow down arrow.

⊙ Result: The drive function should not work in either direction.

47 Lower the platform and drive the machine off the block.

Test the Pothole Guards

Note: The pothole guards should automatically deploy when the platform is raised. The pothole guards activate another limit switch which allows the machine to continue to function. If the pothole guards do not deploy, an alarm sounds and the machine will not drive and lift.

48 Raise the platform.

⊙ Result: When the platform is raised approximately 6.6ft / 2m from the ground, the pothole guards should deploy.

49 Press on the pothole guards on one side, and then the other.

⊙ Result: The pothole guards should not move.

50 Lower the platform.

⊙ Result: The pothole guards should return to the stowed position.

51 Place a 2.0×7.9 in / 5×20 cm or similar piece of wood under a pothole guard. Raise the platform.

⊙ Result: When the platform is raised approximately 6.6ft / 2m from the ground, the pothole alarm will sound at 180 beeps per minute, and the platform controls LED screen readout should display 18.

52 Press the drive function select button.

53 Press and hold the function enable switch on the control handle.

54 Move the control handle in the direction indicated by the blue up arrow, and then move the control handle in the direction indicated by the yellow down arrow.

Function Tests

- ⊙ Result: The drive function should not work in either direction.
- 55 Press and hold the function enable switch on the control handle.
- 56 Depress the thumb rocker switch on top of the control handle in the direction identified by the blue and yellow arrow on the control panel.
- ⊙ Result: The steer function should not work in either direction.
- 57 Lower the platform and remove the 2.0×7.9 in / 5×20 cm wood block.

Operating Instructions



Do Not Operate Unless:

- You learn and practice the principles of safe machine operation contained in this operator's manual.
 - 1 Avoid hazardous situations.
 - 2 Always perform a pre-operation inspection.
 - 3 Inspect the workplace.
 - 4 Always perform function tests prior to use.
 - 5 **Only use the machine as it was intended.**

Fundamentals

This machine is a self-propelled hydraulic lift equipped with a work platform on the scissor mechanism. Vibrations emitted by these machines are not hazardous to an operator in the work platform. The machine can be used to position personnel with their tools and supplies at position above ground level and can be used to reach work areas located above and over machinery or equipment.

The Operating Instructions section provides instructions for each aspect of machine operation.

It is the operator's responsibility to follow all the safety rules and instructions in the operator's manual.

Using the machine for anything other than lifting personnel, along with their tools and materials, to an aerial work site is unsafe and dangerous.

Only trained and authorized personnel should be permitted to operate a machine. If more than one operator is expected to use a machine at different times in the same work shift, they must all be qualified operators and are all expected to follow all safety rules and instructions in the operator's manual. That means every new operator should perform a pre-operation inspection, function tests, and a workplace inspection before using the machine.

Operating Instructions

Emergency Stop

Push in the red Emergency Stop button to the off position at the ground controls or the platform controls to stop all machine functions.

Repair any function that operates when either red Emergency Stop button is pushed in.

Emergency Lowering

- 1 Pull the emergency lowering knob.

Operation from Ground

- 1 Be sure the battery pack is connected before operating the machine.
- 2 Turn the key switch to ground control.
- 3 Pull out the platform and ground red Emergency Stop button to the on position.

To Position Platform

- 1 At the control panel, press and hold the lift function enable button.
- 2 Press the platform up or down button.

Drive and steer functions are not available from the ground controls.

Operation from Platform

- 1 Be sure the battery pack is connected before operating the machine.
- 2 Turn the key switch to platform control.
- 3 Pull out the platform and ground red Emergency Stop button to the on position.

To Position Platform

- 1 Press the lift function select button.
- 2 Press and hold the function enable switch on the control handle.
- 3 Move the control handle according to the markings on the control panel.

To Steer

- 1 Press the drive function select button.
- 2 Press and hold the function enable switch on the control handle.
- 3 Turn the steer wheels with the thumb rocker switch located on the top of the control handle.

To Drive

- 1 Press the drive function select button.
- 2 Press and hold the function enable switch on the control handle.
- 3 Increase speed: Slowly move the control handle off center.

Decrease speed: Slowly move the control handle toward center.

Stop: Return the control handle to center or release the function enable switch.

Use the color-coded direction arrows on the platform controls to identify the direction the machine will travel.

Machine travel speed is restricted when the platform is raised.

Battery condition will affect machine performance. Machine drive speed and function speed will drop when the battery level indicator is flashing.

To reduce drive speed

The drive controls can operate in two different drive speed modes. When the drive speed button light is on, slow drive speed mode is active. When the button light is off, fast drive speed mode is active.

Press the drive speed button to select the desired drive speed.

▲ Driving on a slope

Determine the slope and side slope ratings for the machine and determine the slope grade.

Operating Instructions

JCPT0807 Maximum slope rating, stowed position level 25% (14°), Maximum side slope rating, stowed position level 3°. JCPT0808, JCPT1012, JCPT1008, JPT1212, JCPT1412, JCPT1614 Maximum slope rating, stowed position level 25% (14°), Maximum side slope rating, stowed position level 5°.

Note: Slope rating is subject to ground conditions and adequate traction.

Press the drive speed button to the fast drive speed mode.

To determine the slope grade

Measure the slope with a digital inclinometer OR use the following procedure.

You will need:

Carpenter's level

Straight piece of wood, at least 3.3 ft / 1 m long

Tape measure

Lay the piece of wood on the slope.

At the downhill end, lay the level on the top edge of the piece of wood and lift the end until the piece of wood is level.

While holding the piece of wood level, measure the distance from the bottom of the piece of wood to the ground.

Divide the tape measure distance (rise) by the length of the piece of wood (run) and multiply by 100.

Example:

Run = 12 ft / 3.6 m

Rise = 12 in / 0.3 m

$12 \text{ in} \div 144 \text{ in} = 0.083 \times 100 = 8.3\%$

$0.3 \text{ m} \div 3.6 \text{ m} = 0.083 \times 100 = 8.3\%$



If the slope exceeds the maximum slope or side slope rating, the machine must be winched or transported up or down the slope. See Transport and Lifting section.

Operation from Ground with Controller

Maintain safe distances between operator, machine and fixed objects.

Be aware of the direction the machine will travel when using the controller.

Battery Level Indicator

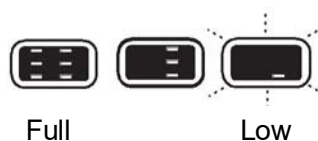

Use the LED readout screen to determine the battery level.

How to use the Safety Arm

- 1 Raise the platform until the distance of the two sets of scissor at least 1.64 ft / 0.5m.
- 2 Lift the safety arm, move it to the center of the scissor arm and rotate up to a vertical position.
- 3 Lift the upper safety arm, move it to the center of the scissor arm and rotate down to a vertical position. (for JCPT1412, JCPT1614).
- 4 Lower the platform until the safety arm rests securely on the link. Keep clear of the safety arm when lowering the platform.

⚠ DANGER Engage all safety arms before performing maintenance or repair.

⚠ DANGER Don't engage the safety arm unless unload the platform.

Operating Instructions

How to Fold Down the Guardrails (JCPT0807)

The platform railing system consists of three fold down rail section for the extension deck and three sections for the main deck. All sections are held in place by four wire lock pins.

- 1 Fully lower the platform and retract the platform extension.
- 2 Remove the platform controls.
- 3 From inside the platform, remove the two front extension deck wire lock pins.
- 4 Fold down the front rail assembly. Keep hands clear of pinch points.
- 5 Replace the two removed pins back into each side rail bracket.
- 6 Fold down the extension platform right rail assembly. Keep hands clear of pinch points.
- 7 Fold down the extension platform left rail assembly. Keep hands clear of pinch points.
- 8 Carefully open the gate and move to the rear step or the ground.
- 9 From the rear step or from the ground, remove the right rear main deck wire lock pins.
- 10 Fold down the right rail assembly. Keep hands clear of pinch points.
- 11 Replace the removed pin back into rear rail bracket.
- 12 Remove the left rear main deck wire lock pins.
- 13 Fold down the left rail assembly. Keep hands clear of pinch points.
- 14 Replace the removed pin back into rear rail bracket.
- 15 Fold down the rear rail assembly. Keep hands free of pinch points.

How to Fold Down the Guardrails (JCPT0808 ~ JCPT1614)

The platform railing system consists of three fold down rail section for the extension deck and three sections for the main deck. All sections are held in place by four wire lock pins.

- 16 Fully lower the platform and retract the platform extension.
- 17 Remove the platform controls.
- 18 From inside the platform, remove the two front extension deck wire lock pins.
- 19 Fold down the front rail assembly. Keep hands clear of pinch points.
- 20 Replace the two removed pins back into each side rail bracket.
- 21 Fold down the extension platform left rail assembly. Keep hands clear of pinch points.
- 22 Fold down the extension platform right rail assembly. Keep hands clear of pinch points.
- 23 Carefully open the gate and move to the rear step or the ground.
- 24 From the rear step or from the ground, remove the left rear main deck wire lock pins.
- 25 Fold down the left rail assembly. Keep hands clear of pinch points.
- 26 Replace the removed pin back into rear rail bracket.
- 27 Remove the right rear main deck wire lock pins.
- 28 Fold down the right rail assembly. Keep hands clear of pinch points.
- 29 Replace the removed pin back into rear rail bracket.

Operating Instructions

- 30 Fold down the rear rail assembly. Keep hands free of pinch points.

How to Raise the Guardrails

Follow the fold down instructions but in reverse order.

To Extend and Retract Platform

- 1 Press the platform lock pin pedal on the extension deck by foot.
- 2 Push the platform extension guardrail to extend the platform to the desired position.

Do not stand on the platform extension while trying to extend it.

Operating Instructions**Error indicator readout**

The LED readout screen displays fault codes that provide information about the machine operating status and about malfunctions. The fault codes listed in the following charts describe malfunctions and can aid in troubleshooting the machine by pinpointing the area or component affected.

List of Fault Codes

| Display | Description | Lift Reaction |
|----------------|------------------------------|-----------------------------|
| 01 | System Initialization Fault | Disables All Motion |
| 02 | System Communication Fault | Disables All Motion |
| 03 | Invalid Option Setting Fault | Disables All Motion |
| 04 | Calibration Fault | Warning Only |
| 08 | Key Switch Error | Disables All Motion |
| 09 | GPS Communication Fault | Warning Only |
| 10 | MC Communication Fault | Warning Only |
| 11 | BMS Communication Fault | Warning Only |
| 12 | Chassis Up or Down Switch ON | Disable Chassis Control |
| 18 | Pothole Guard Fault | Disable Lifting and Driving |
| 31 | 31 Pressure Sensor Fault | Disables All Motion |
| 32 | 32 Angle Sensor Fault | Disables All Motion |
| 35 | 35 Pressure Sensor 2 Fault | Disables All Motion |
| 36 | 36 Battery Drain Alarm | Drive speed limit |
| 42 | 42 Platform Left Button ON | Warning Only |
| 43 | 43 Platform Right Button ON | Warning Only |
| 46 | 46 Platform Enable Button ON | Disable Platform Control |
| 47 | 47 Joystick Not In Neutral | Drive speed limit |
| 52 | 52 Drive Forward Coil Fault | Disable Lifting and Driving |
| 53 | 53 Drive Reverse Coil Fault | Disable Lifting and Driving |
| 54 | 54 Lift Up Coil Fault | Disable Lifting and Driving |
| 55 | 55 Lift Down Coil Fault | Disable Lifting and Driving |

Operating Instructions

| Display | Description | Lift Reaction |
|----------------------------|------------------------------------|-----------------------------|
| 56 | 56 Steer Right Coil Fault | Disable Lifting and Driving |
| 57 | 57 Steer Left Coil Fault | Disable Lifting and Driving |
| 59 | 59 Parallel Coil Fault | Disable Lifting and Driving |
| 68 | Battery Low Voltage | Disables All Motion |
| 80 | Platform Load is over 80% | Warning Only |
| 90 | Platform Load is over 90% | Warning Only |
| 99 | Platform Load is over 99% | Warning Only |
| OL | Platform Overloaded | Disable All Motion |
| LL | Machine Tiled | Disable Lifting and Driving |
| UP | Platform up limit position | Warning Only |
| 102 | Restore Parameters to Default | Warning Only |
| 103 | Battery is draining | Warning Only |
| 104 | Motor Controller Fault | Warning Only |
| 105 | BMS Alarm | Drive speed limit |
| 106 | BMS Fault | Disable All Motion |
| PCU: n1, ECU: 1xxx code | Left Drive Motor Controller Fault | Controller Dependent |
| PCU:n2, ECU: 2xxx code | Right Drive Motor Controller Fault | Controller Dependent |
| PCU: n3, ECU: 3xxx code | Pump Motor Controller Fault | Controller Dependent |
| PCU: n4, ECU:4xxx code | BMS Fault | BMS Dependent |

List of Fault Codes (motor controller)

| Display | Description | Lift Reaction |
|------------------|------------------|----------------------|
| 1008, 2008, 3008 | WATCHDOG | Controller Dependent |
| 1017, 2017, 3017 | LOGIC FAILURE #3 | Controller Dependent |

Operating Instructions

| Display | Description | Lift Reaction |
|------------------|--------------------|----------------------|
| 1018, 2018, 3018 | LOGIC FAILURE #2 | Controller Dependent |
| 1019, 2019, 3019 | LOGIC FAILURE #1 | Controller Dependent |
| 1028, 2028, 3028 | PUMP VMN LOW | Controller Dependent |
| 1029, 2029, 3029 | PUMP VMN HIGH | Controller Dependent |
| 1030, 2030, 3030 | VMN LOW | Controller Dependent |
| 1031, 2031, 3031 | VMN HIGH | Controller Dependent |
| 1037, 2037, 3037 | CONTACTOR CLOSED | Controller Dependent |
| 1038, 2038, 3038 | CONTACTOR OPEN | Controller Dependent |
| 1052, 2052, 3052 | PUMP I=0 EVER | Controller Dependent |
| 1053, 2053, 3053 | STBY I HIGH | Controller Dependent |
| 1060, 2060, 3060 | CAPACITOR CHARGE | Controller Dependent |
| 1062, 2062, 3062 | TH. PROTECTION | Controller Dependent |
| 1065, 2065, 3065 | MOTOR TEMPERAT. | Controller Dependent |
| 1066, 2066, 3066 | BATTERY LOW | Controller Dependent |
| 1074, 2074, 3074 | DRIVER SHORTED | Controller Dependent |
| 1075, 2075, 3075 | CONTACTOR DRIVER | Controller Dependent |
| 1078, 2078, 3078 | VACC NOT OK | Controller Dependent |
| 1079, 2079, 3079 | INCORRECT START | Controller Dependent |
| 1080, 2080, 3080 | FORW + BACK | Controller Dependent |
| 1086, 2086, 3086 | PEDAL WIRE KO | Controller Dependent |
| 1152, 2152, 3152 | IIC BUS ERROR | Controller Dependent |
| 1153, 2153, 3153 | ENCODER ERROR XX | Controller Dependent |
| 1154, 2154, 3154 | OUT MISMATCHXX | Controller Dependent |
| 1155, 2155, 3155 | SP MISMATCHXX | Controller Dependent |
| 1157, 2157, 3157 | INPUT MISMATCHXX | Controller Dependent |
| 1158, 2158, 3158 | NOT RDY DRV.POW. | Controller Dependent |
| 1159, 2159, 3159 | HVIL FAIL | Controller Dependent |

Operating Instructions

| Display | Description | Lift Reaction |
|------------------|------------------|----------------------|
| 1160, 2160, 3160 | SENS BAT TEMP KO | Controller Dependent |
| 1161, 2161, 3161 | RPM HIGH | Controller Dependent |
| 1162, 2162, 3162 | BUMPER STOP | Controller Dependent |
| 1163, 2163, 3163 | ED SLIP MISMATCH | Controller Dependent |
| 1164, 2164, 3164 | PWM ACQ. ERROR | Controller Dependent |
| 1168, 2168, 3168 | SIN/COS D.ERR XX | Controller Dependent |
| 1169, 2169, 3169 | ENCODER D.ERR XX | Controller Dependent |
| 1170, 2170, 3170 | WRONG KEY VOLT. | Controller Dependent |
| 1171, 2171, 3171 | ACQUIRING A.S. | Controller Dependent |
| 1172, 2172, 3172 | ACQUIRE ABORT | Controller Dependent |
| 1173, 2173, 3173 | ACQUIRE END | Controller Dependent |
| 1174, 2174, 3174 | OFFSET SPD.SENS. | Controller Dependent |
| 1175, 2175, 3175 | SPEED FB. ERROR | Controller Dependent |
| 1176, 2176, 3176 | HOME SENS.ERR XX | Controller Dependent |
| 1177, 2177, 3177 | COIL SHOR. EB. | Controller Dependent |
| 1178, 2178, 3178 | MOTOR TEMP. STOP | Controller Dependent |
| 1179, 2179, 3179 | STEER SENSOR KO | Controller Dependent |
| 1180, 2180, 3180 | OVERLOAD | Controller Dependent |
| 1181, 2181, 3181 | WRONG ENC SET | Controller Dependent |
| 1185, 2185, 3185 | TILLER ERROR | Controller Dependent |
| 1186, 2186, 3186 | WAIT MOT.P STILL | Controller Dependent |
| 1187, 2187, 3187 | LIFT+LOWER | Controller Dependent |
| 1188, 2188, 3188 | INT. CANBUSKO | Controller Dependent |
| 1189, 2189, 3189 | PUMP INC START | Controller Dependent |
| 1190, 2190, 3190 | PUMP VMN NOT OK | Controller Dependent |
| 1191, 2191, 3191 | PUMP VACC NOT OK | Controller Dependent |
| 1192, 2192, 3192 | PUMP VACC RANGE | Controller Dependent |

Operating Instructions

| Display | Description | Lift Reaction |
|------------------|--------------------|----------------------|
| 1193, 2193, 3193 | SMARTDRIVER KO | Controller Dependent |
| 1194, 2194, 3194 | AUX BATT. SHORT. | Controller Dependent |
| 1195, 2195, 3195 | POS. EB. SHORTED | Controller Dependent |
| 1196, 2196, 3196 | MOT.PHASE SH. | Controller Dependent |
| 1197, 2197, 3197 | WRONG SLAVE VER. | Controller Dependent |
| 1198, 2198, 3198 | M/S PAR CHK MISM | Controller Dependent |
| 1199, 2199, 3199 | PARAM TRANSFER | Controller Dependent |
| 1200, 2200, 3200 | VDC OFF SHORTED | Controller Dependent |
| 1201, 2201, 3201 | TORQUE PROFILE | Controller Dependent |
| 1202, 2202, 3202 | VDC LINK OVERV. | Controller Dependent |
| 1204, 2204, 3204 | BRAKE RUN OUT | Controller Dependent |
| 1205, 2205, 3205 | EPS RELAY OPEN | Controller Dependent |
| 1206, 2206, 3206 | INIT VMN HIGH | Controller Dependent |
| 1207, 2207, 3207 | INIT VMN LOW | Controller Dependent |
| 1208, 2208, 3208 | EEPROM KO | Controller Dependent |
| 1209, 2209, 3209 | PARAM RESTORE | Controller Dependent |
| 1210, 2210, 3210 | WRONG RAM MEM. | Controller Dependent |
| 1211, 2211, 3211 | STALL ROTOR | Controller Dependent |
| 1212, 2212, 3212 | POWER MISMATCH | Controller Dependent |
| 1213, 2213, 3213 | POSITIVE LC OPEN | Controller Dependent |
| 1214, 2214, 3214 | EVP COIL OPEN | Controller Dependent |
| 1215, 2215, 3215 | EVP DRIV. SHORT. | Controller Dependent |
| 1216, 2216, 3216 | EB. COIL OPEN | Controller Dependent |
| 1217, 2217, 3217 | PEB NOT OK | Controller Dependent |
| 1218, 2218, 3218 | SENS MOT TEMP KO | Controller Dependent |
| 1220, 2220, 3220 | VKEY OFF SHORTED | Controller Dependent |
| 1221, 2221, 3221 | HANDBRAKE | Controller Dependent |

Operating Instructions

| Display | Description | Lift Reaction |
|------------------|------------------|----------------------|
| 1223, 2223, 3223 | COIL SHOR.MC | Controller Dependent |
| 1224, 2224, 3224 | WAITING FOR NODE | Controller Dependent |
| 1224, 2224, 3224 | WAITING FOR NODE | Controller Dependent |
| 1224, 2224, 3224 | WAITING FOR NODE | Controller Dependent |
| 1226, 2226, 3226 | VACC OUT RANGE | Controller Dependent |
| 1227, 2227, 3227 | HW FAULT | Controller Dependent |
| 1228, 2228, 3228 | TILLER OPEN | Controller Dependent |
| 1229, 2229, 3229 | HW FAULT EB. | Controller Dependent |
| 1230, 2230, 3230 | LC COIL OPEN | Controller Dependent |
| 1231, 2231, 3231 | PUMP I NO ZERO | Controller Dependent |
| 1232, 2232, 3232 | CONT. DRV. EV | Controller Dependent |
| 1233, 2233, 3233 | POWERMOS SHORTED | Controller Dependent |
| 1234, 2234, 3234 | DRV. SHOR. EV | Controller Dependent |
| 1235, 2235, 3235 | CTRAP THRESHOLD | Controller Dependent |
| 1236, 2236, 3236 | CURRENT GAIN | Controller Dependent |
| 1237, 2237, 3237 | ANALOG INPUT | Controller Dependent |
| 1238, 2238, 3238 | HW FAULT EV. | Controller Dependent |
| 1239, 2239, 3239 | CONTROLLER MISM. | Controller Dependent |
| 1240, 2240, 3240 | EVP DRIVER OPEN | Controller Dependent |
| 1241, 2241, 3241 | COIL SHOR. EVAUX | Controller Dependent |
| 1242, 2242, 3242 | OPEN COIL EV. | Controller Dependent |
| 1243, 2243, 3243 | THROTTLE PROG. | Controller Dependent |
| 1244, 2244, 3244 | WARNING SLAVE | Controller Dependent |
| 1245, 2245, 3245 | IQMISMATCHED | Controller Dependent |
| 1246, 2246, 3246 | EB. DRIV.OPEN | Controller Dependent |
| 1247, 2247, 3247 | DATAACQUISITION | Controller Dependent |
| 1248, 2248, 3248 | NO CAN MSG. | Controller Dependent |

Operating Instructions

| Display | Description | Lift Reaction |
|------------------|--------------------|----------------------|
| 1249, 2249, 3249 | CHECK UP NEEDED | Controller Dependent |
| 1250, 2250, 3250 | THERMIC SENS. KO | Controller Dependent |
| 1251, 2251, 3251 | WRONG SET BAT. | Controller Dependent |
| 1253, 2253, 3253 | FIELD ORIENT. KO | Controller Dependent |
| 1254, 2254, 3254 | EB. DRIV.SHRT. | Controller Dependent |

List of Fault Codes (Battery BMS)

| Display | Description | Lift Reaction |
|----------------|--------------------------------|----------------------------|
| 4001 | Low charging temperature 2 | Lift and Drive speed limit |
| 4002 | Low charging temperature 3 | Disables All Motion |
| 4003 | High charging temperature 2 | Lift and Drive speed limit |
| 4004 | High charging temperature 3 | Disables All Motion |
| 4005 | Low discharging temperature 2 | Lift and Drive speed limit |
| 4006 | High discharging temperature 3 | Disables All Motion |
| 4007 | Low discharging temperature 2 | Lift and Drive speed limit |
| 4008 | High discharging temperature 3 | Disables All Motion |
| 4009 | Temperature imbalance 2 | Lift and Drive speed limit |
| 4010 | Temperature imbalance 3 | Disables All Motion |
| 4011 | Pad Temperature high 2 | Lift and Drive speed limit |
| 4012 | Pad Temperature high 3 | Disables All Motion |
| 4013 | Low SOC 2 | Lift and Drive speed limit |
| 4014 | Low SOC 3 | Disables All Motion |
| 4015 | High SOC 2 | Lift and Drive speed limit |
| 4016 | High SOC 3 | Disables All Motion |
| 4017 | Discharge total voltage high 2 | Lift and Drive speed limit |
| 4018 | Discharge total voltage high 3 | Disables All Motion |
| 4019 | Discharge total voltage low 2 | Lift and Drive speed limit |

Operating Instructions

| Display | Description | Lift Reaction |
|---------|-------------------------------|----------------------------|
| 4020 | Discharge total voltage low 3 | Disables All Motion |
| 4021 | Charge total voltage high 2 | Lift and Drive speed limit |
| 4022 | Charge total voltage high 3 | Disables All Motion |
| 4023 | High charge current 2 | Lift and Drive speed limit |
| 4024 | High charge current 3 | Disables All Motion |
| 4025 | High discharge current 2 | Lift and Drive speed limit |
| 4026 | High discharge current 2 | Disables All Motion |
| 4027 | Discharge cell voltage high 2 | Lift and Drive speed limit |
| 4028 | Discharge cell voltage high 3 | Disables All Motion |
| 4029 | Discharge cell voltage low 2 | Lift and Drive speed limit |
| 4030 | Discharge cell voltage low 3 | Disables All Motion |
| 4031 | Charge cell voltage low 2 | Lift and Drive speed limit |
| 4032 | Charge cell voltage low 3 | Disables All Motion |
| 4033 | Cell voltage imbalance 2 | Lift and Drive speed limit |
| 4034 | Cell voltage imbalance 3 | Disables All Motion |
| 4035 | Main relay adhesion 2 | Lift and Drive speed limit |
| 4036 | Main relay adhesion 3 | Disables All Motion |
| 4037 | Heating relay adhesion 2 | Lift and Drive speed limit |
| 4038 | Heating relay adhesion 3 | Disables All Motion |
| 4039 | High monomer 2 | Lift and Drive speed limit |
| 4040 | High monomer 3 | Disables All Motion |
| 4041 | Low monomer 2 | Lift and Drive speed limit |
| 4042 | Low monomer 3 | Disables All Motion |
| 4043 | High temperature 2 | Lift and Drive speed limit |
| 4044 | High temperature 3 | Disables All Motion |

For more information, please consult the appropriate Dingli Service Dept.

Operating Instructions



Battery and Charger Instructions

Observe and Obey:

- Do not use an external charger or booster battery.
- Charge the battery in a well-ventilated area.
- Use proper AC input voltage for charging as indicated on the charger.
- Use only a Dingli authorized battery and charger.
- Charge the battery as soon as receive the machine or after long distance transportation
- When the battery is stored for a long time, it needs to be charged regularly. Failure to charge in time may permanently damage the battery.

To Charge Battery

- 1 Be sure the batteries are connected before charging.
- 2 Open the battery compartment. The compartment should remain open for the entire charging cycle.

Maintenance - free battery

- 3 Connect the battery charger to a grounded AC circuit.
- 4 The charger will indicate when the battery is fully charged.

Standard Battery

- 5 Remove the battery vent caps and check the battery acid level. If necessary, add only enough distilled water to cover the plates. Do not overfill prior to the charge cycle.
- 6 Replace the battery vent caps.
- 7 Connect the battery charger to a grounded AC circuit.
- 8 The charger will indicate when the battery is fully charged.
- 9 Check the battery acid level when the charging cycle is complete. Replenish with distilled water to the bottom of the fill tube. Do not overfill.

Lithium battery

- 10 During the charging operation, professional personnel should take care of it. During the charging process, the plug and socket should be in good contact, the charging equipment should work normally, and the connection points of the battery

Operating Instructions

pack should be in good contact. If something goes wrong, it needs to be fixed before it can be charged.

- 11 During charging and discharging, try to avoid water or other conductive objects splashing on the battery cover and pole.
- 12 Avoid charging at low temperature (below 0 °C) to ensure battery life

Dry Battery Filling and Charging Instructions

- 1 Remove the battery vent caps and permanently remove the plastic seal from the battery vent openings.
- 2 Fill each cell with battery acid (electrolyte) until the level is sufficient to cover the plates.

Do not fill to maximum level until the battery charge cycle is complete. Overfilling can cause the battery acid to overflow during charging. Neutralize battery acid spills with baking soda and water.

- 3 Install the battery vent caps.
- 4 Charge the battery.
- 5 Check the battery acid level when the charging cycle is complete. Replenish with distilled water to the bottom of the fill tube. Do not overfill.

Note: In order to achieve an optimal service life, discharge of over 60% of the rated capacity should be avoided. Discharge of over 80% of the rated capacity is a deep discharge and is not permissible. These significantly reduce the service life of the battery. Only those discharge state indicators that have been approved by the battery manufacturer may be used.

Discharged batteries must be charged immediately and must not remain in

discharged state. This also applies to batteries in a state of deep discharge. Otherwise, the service life of the battery will be significantly reduced. The battery may freeze when in discharged state

Charge the battery immediately when the machine displays "36" or "68" alarm code during work.

During the charging process, if temperatures are consistently higher than 40°C or lower than 15°C, stop charging to check whether the battery and charger are normal..

Transport and Lifting Instructions



Observe and Obey:

- ✓ Common sense and planning must be applied to control the movement of the machine when lifting it with a crane or forklift.
- ✓ Only qualified aerial lift operators should move the machine on or off the truck.
- ✓ The transport vehicle must be parked on a level surface.
- ✓ The transport vehicle must be secured to prevent rolling while the machine is being loaded.
- ✓ Be sure the vehicle capacity, loading surfaces and chains or straps are sufficient to withstand the machine weight. See the serial label for the machine weight.
- ✓ The machine must be on a level surface or secured before releasing the brakes.
- ✓ Do not allow the rails to fall when the snap pins are removed. Maintain a firm grasp on the rails when the rails are lowered.
- ✓ Do not drive the machine on a slope that exceeds the slope or side slope rating. See Driving on a Slope in the Operating Instructions section.
- ✓ If the slope of the transport vehicle bed exceeds the maximum slope rating, the machine must be loaded and unloaded using a winch as described.

Brake Release Operation

For the Hydraulic Motor Drive Model

- 1 Chock the wheels to prevent the machine from rolling.
- 2 Be sure the winch line is properly secured to the drive chassis tie points and the path is clear of all obstructions.
- 3 Push in the black brake release knob to open the brake valve.
- 4 Pump the red brake release pump knob.
- 5 If you want to close the brake release, just pull out the black brake release knob.

For the Electric Motor Drive Model

- 1 Chock the wheels to prevent the machine from rolling.
- 2 Pull out the platform and emergency red Emergency Stop button to the on position.
- 3 Turn the key switch to the ground controller.
- 4 At the same time, long press the "Enter" button on the ECU panel to enter the the password input screen .
- 5 Press the "Menu enter button" 4 times to enter the Menu screen .
- 6 Press the "up" or "down" button to switch to the Special mode (" 4. Special Mode ")
- 7 Press the "Enter" button to display the Special mode. Press the "up" or "down" button to switch to the manual push menu (" 1. Brake Release ")
- 8 Press "Enter" button to display "long press to confirm release of brake". Long press the "enter" button to show "Brake

Transport and Lifting Instructions

released!" Release all brakes.

- 9 If you want to close the brake release, just turn off the key switch in "ground" position.

Towing the Hydraulic Drive Model is not recommended. If the machine must be towed, do not exceed 2.2 mph / 3.5 km/h.

Towing the Electric Motor Drive Model is not recommended. If the machine must be towed, do not exceed 2.8 mph / 4.5 km/h.

Securing to Truck or Trailer for Transit

Always chock the machine wheels in preparation for transport.

Retract and secure the extension deck(s).

Turn the key switch to the off position and remove the key before transporting.

Inspect the entire machine for loose or unsecured items.

Use the tie-down points on the chassis for anchoring down to the transport surface.

Use a minimum of four chains or straps.

Use chains or straps of ample load capacity.

If the railings have been folded down, secure them with straps before transporting.

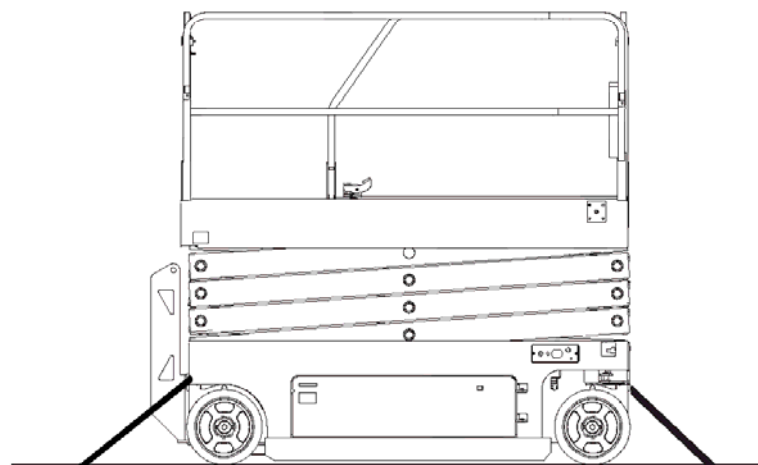
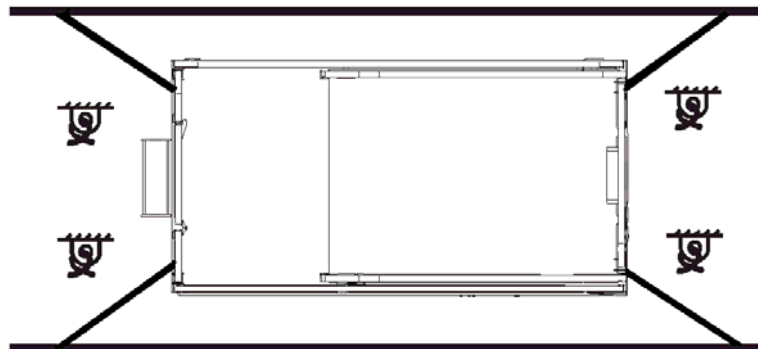

Transport and Lifting Instructions



Observe and Obey:

- Only qualified riggers should rig and lift the machine.
- Only qualified forklift operators should lift the machine with a forklift.
- Be sure the crane capacity, loading surfaces and straps or lines are sufficient to withstand the machine weight. See the serial plate for the machine weight.

Lifting the Machine with a Forklift

Be sure the extension deck, controls and component trays are secure. Remove all loose items on the machine.

Fully lower the platform. The platform must remain lowered during all loading and transport procedures.

Use the forklift pockets located on both sides of the ladder.

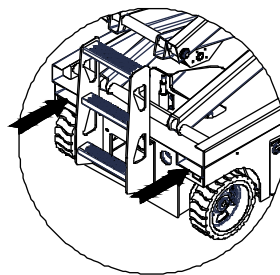

Position the forklift forks in position with the forklift pockets.

Drive forward to the full extent of the forks.

Raise the machine 6 in / 15 cm and then tilt the forks back slightly to keep the machine secure.

Be sure the machine is level when lowering the forks.

NOTICE

Lifting the machine from the side can result in component damage.

Transport and Lifting Instructions

Lifting Instructions

Fully lower the platform. Be sure the extension decks, controls and covers are secure.

Remove all loose items on the machine.

Determine the center of gravity of your machine using the table and the picture on this page.

Attach the rigging only to the designated lifting points on the machine. There are two lifting points on each end of the machine.

Adjust the rigging to prevent damage to the machine and to keep the machine level.

Center of gravity

| Model | X Axis | Y Axis |
|------------|---------|---------|
| JCPT0807HA | 23.6 in | 23.3 in |
| JCPT0807AC | 60 cm | 59.1 cm |
| JCPT0808HA | 35.6 in | 22.2 in |
| JCPT0808AC | 90.5 cm | 56.5 cm |
| JCPT1008HA | 31.7 in | 22.7 in |
| JCPT1008AC | 80.6 cm | 57.6 cm |
| JCPT1012HA | 35 in | 25.4 in |
| JCPT1012AC | 89 cm | 64.4 cm |
| JCPT1212HA | 32.7 in | 26.9 in |
| JCPT1212AC | 83 cm | 68.2 cm |
| JCPT1412HA | 32.7 in | 28.4 in |
| JCPT1412AC | 83 cm | 72.1cm |
| JCPT1614HA | 38.6 in | 27.8 in |
| JCPT1614AC | 98 cm | 70.5cm |

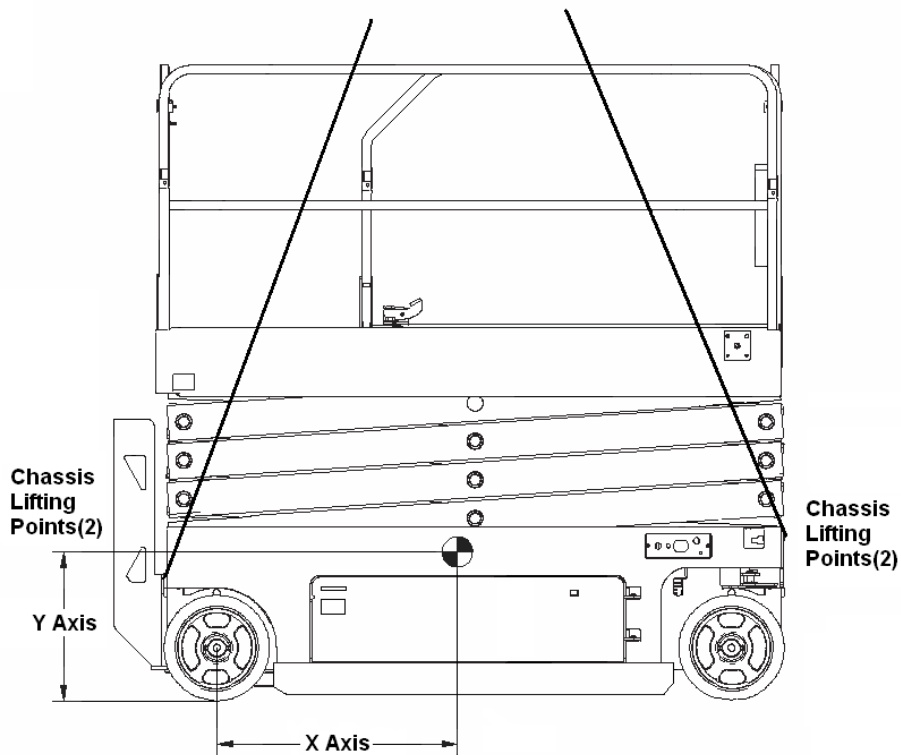

**Observe and Obey:**

- ☑ The storage of the machine shall be as follows, Incorrect storage may affect the performance and service life of the machine
- 1 The machine should be stored indoor coeditor and the ground should be firm and level. If be stored in outdoor condition the machine should be covered to prevent the water and dust.
- 2 Ensure the machine have been cleaned and the functional before stop to the storage. Repair an maintain it if necessary.
- 3 Stop the machine in suitable position so as the drive or move the machines conveniently.

Rust protection

- 1 Before the machine is stored into the storage. Inspecting the paint before the machine is stored into the storage repaint the machine partly all completely against the damage.
- 2 For moving parts grease can be applied to prevent rust, such as bearings, joints and sliding rails

⚠ CAUTION The machine be stored long time cannot be used to service until it has been inspected and maintained according to the daily check procedure.

How to store the batteries

- 1 When storing the machine for a long time (one month to six months) be sure to turn off the main power switch, key switch and emergency stop switch, fully charge. In order to ensure that these batteries stay ready for operation, the following charging procedures must be applied:
The machine or check the voltage of each battery on the machine once a month to ensure that the voltage of battery is not lower than 25.2V, otherwise please charge the machine immediately.
- 2 When storing the machine for a long time (half a year or more), should be fully charged state. The batteries should be removed from the machine. keep the batteries being clean and ensure nothing being placed on the top of batteries. The batteries connection should be disconnection as bellow. Disconnect the wire from the negative pole first the disconnect the wires from the positive pole. The batteries should be connected as bellow: First connect the positive power wires with the positive pole then connect the negative cable line to the negative pole finally. In order to ensure that these batteries stay ready for operation, the batteries should be charged one time in every quarter.

Lithium battery storage

- 1 When storing the machine for a long time, be sure to turn off the main power switch, key switch and emergency stop switch and fully charge it
- 2 In order to avoid the loss of power and the impact on the service life of the battery, the

Storage

negative pole of the battery should be removed and the lithium battery should be charged regularly once a month

- 3 Lithium batteries should be stored in a dry, frost-free room.
- 4 Avoid contact between lithium batteries and corrosive objects, and keep away from places with fire sources and heat sources. The electrode should be insulated when stored (e.g. cover with protective cover) to ensure that no metal part is exposed to prevent short circuit.
- 5 If there are more than 10 groups of batteries in centralized storage, it is better to install a camera for 24-hour monitoring.

The following conditions can result in battery serious injuries:

- The battery was not charged in time when the machine displays "36" or "68" alarm code during work.
- Leave the Key Switch, Emergency Switch or Power Switch on.
- Forget to charge the battery regularly when storing the machine for a long time.

Maintenance



Observe and Obey:

- Only routine maintenance items specified in this manual shall be performed by the operator.
- Scheduled maintenance inspections shall be completed by qualified service technicians, according to the manufacturer's specifications and the requirements specified in this manual.

Maintenance Symbols Legend

NOTICE

The following symbols have been used in this manual to help communicate the intent of the instructions. When one or more of the symbols appear at the beginning of a maintenance procedure, it conveys the meaning below.



Indicates that tools will be required to perform this procedure.



Indicates that new parts will be required to perform this procedure.



Indicates that dealer service will be required to perform this procedure.

Pre-delivery Preparation Report

The pre-delivery preparation report contains checklists for each type of scheduled inspection.

Make copies of the Pre-delivery Preparation report to use for each inspection. Store completed forms as required.

Maintenance Schedule

There are five types of maintenance inspections that must be performed according to a schedule— daily, quarterly, semi-annually, annually, and two year. The Scheduled Maintenance Procedures Section and the Maintenance Inspection Report have been divided into five subsections—A, B, C, D, and E. Use the following chart to determine which group(s) of procedures are required to perform a scheduled inspection.

| Inspection | Checklist |
|----------------------------------|-----------|
| Daily or every 8 hours | A |
| Quarterly or every 250 hours | A+B |
| Semi-annually or every 500 hours | A+B+C |
| Annually or every 1000 hours | A+B+C+D |
| Two year or every 2000 hours | A+B+C+D+E |

Maintenance Inspection Report

The maintenance inspection report contains checklists for each type of scheduled inspection.

Make copies of the Maintenance Inspection Report to use for each inspection. Maintain completed forms for a minimum of 4 years or in compliance with your employer, jobsite and governmental regulations and requirements.

Maintenance

Pre-delivery Preparation Report

Fundamentals

It is the responsibility of the dealer to perform the Pre-delivery Preparation.

The Pre-delivery Preparation is performed prior to each delivery. The inspection is designed to discover if anything is apparently wrong with a machine before it is put into service.

A damaged or modified machine must never be used. If damage or any variation from factory delivered condition is discovered, the machine must be tagged and removed from service.

Repairs to the machine may only be made by a qualified service technician, according to the manufacturer's specifications.

Scheduled maintenance inspections shall be performed by qualified service technicians, according to the manufacturer's specifications and the requirements listed in this manual.

Instructions

Use the operator's manual on your machine.

The Pre-delivery Preparation consists of completing the Pre-operation Inspection, the Maintenance items and the Function Tests.

Use this form to record the results. Place a check in the appropriate box after each part is completed. Follow the instructions in the operator's manual.

If any inspection receives an N, remove the machine from service, repair and re-inspect it. After repair, place a check in the R box.

Legend

Y = yes, completed

N = no, unable to complete

R = repaired

Comments

| Pre-Delivery Preparation | Y | N | R |
|------------------------------------|---|---|---|
| Pre-operation inspection completed | | | |
| Maintenance items completed | | | |
| Function tests completed | | | |

Model

Serial number

Date

Machine owner

Inspected by (print)

Inspector signature

Inspector title

Inspector company

Maintenance

Maintenance Inspection Report

| |
|---|
| Model |
| Serial number |
| Date |
| Hour meter |
| Machine owner |
| Inspected by (print) |
| Inspector signature |
| Inspector title |
| Inspector company |
| Instructions |
| <ul style="list-style-type: none"> • Make copies of this report to use for each inspection. • Select the appropriate checklist(s) for the type of inspection to be performed. |
| <input type="checkbox"/> Daily or 8 hours Inspection: A |
| <input type="checkbox"/> Quarterly or 250 hours Inspection: A+B |
| <input type="checkbox"/> Semi-annually or 500 hours Inspection: A+B+C |
| <input type="checkbox"/> Annually or 1000 hours Inspection: A+B+C+D |
| <input type="checkbox"/> Two year or 2000 hours Inspection: A+B+C+D+E |
| <ul style="list-style-type: none"> • Place a check in the appropriate box after each inspection procedure is completed. • Use the step-by-step procedures in this section to learn how to perform these inspections. • If any inspection receives an "N", tag and remove the machine from service, repair and re-inspect it. After repair, place a check in the "R" box. |
| Legend |
| Y = yes, acceptable |
| N = no, remove from service |
| R = repaired |

| Checklist A | Y | N | R |
|---|----------|----------|----------|
| A-1 Inspect the manuals and decals | | | |
| A-2 Pre-operation inspection | | | |
| A-3 Check the Batteries | | | |
| A-4 Check the Hydraulic Oil Level | | | |
| A-5 Function tests | | | |
| Perform after 40 hours: | | | |
| A-6 30 day service | | | |
| Checklist B | Y | N | R |
| B-1 Batteries | | | |
| B-2 Electrical wiring | | | |
| B-3 Tires and wheels | | | |
| B-4 Emergency stop | | | |
| B-5 Key switch | | | |
| B-6 Horn (if equipped) | | | |
| B-7 Drive brakes | | | |
| B-8 Drive speed - stowed | | | |
| B-9 Drive speed - raised | | | |
| B-10 Drive speed - slow | | | |
| B-11 Hydraulic oil analysis | | | |
| B-12 Tank venting system | | | |
| B-13 Latch components | | | |
| B-14 Test the pothole limit switches and the level Sensor | | | |
| Checklist C | Y | N | R |
| C-1 Platform overload (if equipped) | | | |
| C-2 Breather cap - models with optional oil | | | |
| Checklist D | Y | N | R |
| D-1 Scissor arm wear pads | | | |
| D-2 Hydraulic filter | | | |
| Checklist E | Y | N | R |
| E-1 Hydraulic oil | | | |

Maintenance

Checklist A Procedures

A-1

Inspect the Manuals and Decals

Maintaining the operator's manual in good condition is essential to safe machine operation. Manuals are included with each machine and should be stored in the container provided in the platform. An illegible or missing manual will not provide safety and operational information necessary for a safe operating condition.

In addition, maintaining all of the safety and instructional decals in good condition is mandatory for safe machine operation. Decals alert operators and personnel to the many possible hazards associated with using this machine. They also provide users with operation and maintenance information. An illegible decal will fail to alert personnel of a procedure or hazard and could result in unsafe operating conditions.

- 1 Check to make sure that the operator's manual is present and complete in the storage container on the platform.
- 2 Examine the pages of manual to be sure that they are legible and in good condition.

☉ Result: The operator's manual is appropriate for the machine and the manual are legible and in good condition.

☒ Result: The operator's manual is not appropriate for the machine or the manual is not in good condition or is illegible. Remove the machine from service until the manual is replaced.

- 3 Open the operator's manual to the decals inspection section. Carefully and thoroughly inspect all decals on the machine for legibility and damage.

☉ Result: The machine is equipped with all required decals, and all decals are legible and in good condition.

☒ Result: The machine is not equipped with all required decals, or one or more decals are illegible or in poor condition. Remove the machine from service until the decals are replaced.

- 4 Always return the manual to the storage container after use.

Note: Contact your authorized DINGLI distributor or DINGLI machinery if replacement manuals or decals are needed.

A-2**Perform Pre-operation Inspection**

Completing a Pre-operation Inspection is essential to safe machine operation. The Pre-operation Inspection is a visual inspection performed by the operator prior to each work shift. The inspection is designed to discover if anything is apparently wrong with a machine before the operator performs the function tests. The Pre-operation Inspection also serves to determine if routine maintenance procedures are required.

Complete information to perform this procedure is available in the appropriate operator's manual. Refer to the operator's manual on your machine.

A-3**Check the Batteries**

Proper battery condition is essential to good machine performance and operational safety. Improper fluid levels or damaged cables and connections can result in component damage and hazardous conditions.

Note: This check is not required for machines with lithium batteries, sealed batteries, or Maintenance - free batteries.

⚠ WARNING Electrocutation hazard.

Contact with hot or live circuits may result in death or serious injury. Remove all rings, watches and other jewelry.

⚠ WARNING Bodily injury hazard.

Batteries contain acid. Avoid spilling or contacting battery acid. Neutralize battery acid spills with baking soda and water.

- 1 Put on protective clothing and eye wear.
- 2 Be sure that the battery cable connections are tight and free of corrosion.
- 3 Be sure that the battery hold-down bars are secure.
- 4 Remove the battery vent caps.
- 5 Check the battery acid level. If needed, replenish with distilled water to the bottom of the battery fill tube. Do not overfill.
- 6 Install the vent caps.

Maintenance

A-4

Check the Hydraulic Oil Level



Maintaining the hydraulic oil at the proper level is essential to machine operation. Improper hydraulic oil levels can damage hydraulic components. Daily checks allow the inspector to identify changes in oil level that might indicate the presence of hydraulic system problems.

NOTICE

Perform this procedure with the platform in the stowed position.

- 1 Visually inspect the sight of hydraulic oil level from the side of the hydraulic oil tank.

⊙ Result: The hydraulic oil level should be at the mark of the fuel tank. (Refer to the following table).

| Model | Scale line (L) |
|---|----------------|
| JCPT0807HA/AC | 7.2 |
| JCPT0808HA/AC JCPT1008HA/AC JCPT1012HA/AC | 15 |
| JCPT1212HA/AC JCPT1412HA/AC | 17.5 |
| JCPT1614HA/AC | 19 |

- 2 Add oil if necessary. Do not overfill.

NOTICE

Original Hydraulic oil specifications: L-HV46

Customers shall choose the appropriate hydraulic oil according to the ambient temperature used.

Example: L-HV32 or L-HV68

A-5

Perform Function Tests

Completing the function tests is essential to safe machine operation. Function tests are designed to discover any malfunctions before the machine is put into service. A malfunctioning machine must never be used. If malfunctions are discovered, the machine must be tagged and removed from service.

Complete information to perform this procedure is available in the appropriate operator's manual. Refer to the operator's manual on your machine.

A-6

Perform 30 Day Service



The 30 day maintenance procedure is a one time procedure to be performed after the first 30 days or 40 hours of usage. After this interval, refer to the maintenance tables for continued scheduled maintenance.

Perform the following maintenance procedures:

- B-3 Inspect the Tires, Wheels and Castle Nut Torque
- D-2 Replace the Hydraulic Tank Return Filter Element

Checklist B Procedures**B-1****Inspect the Batteries**

DINGLI requires that this procedure be performed every 250 hours or quarterly, whichever comes first.

Proper battery condition is essential to good machine performance and operational safety. Improper fluid levels or damaged cables and connections can result in component damage and hazardous conditions.

⚠ WARNING Electrocutation / burn hazard. Contact with electrically charged circuits could result in death or serious injury. Remove all rings, watches and other jewelry.

⚠ WARNING Bodily injury hazard. Batteries contain acid. Avoid spilling or contacting battery acid. Neutralize battery acid spills with baking soda and water.

- 1 Put on protective clothing and eye wear.
- 2 Release the battery pack latch and rotate the battery pack out and away from the chassis.
- 3 Be sure that the battery cable connections are free of corrosion.

Note: Adding terminal protectors and a corrosion preventative sealant will help eliminate corrosion on the battery terminals and cables.

- 4 Be sure that the battery retainers and cable connections are tight.
- 5 Fully charge the batteries. Allow the batteries to rest 24 hours before performing this procedure to allow the battery cells to equalize.

Models without maintenance-free or sealed batteries:

- 6 Remove the battery vent caps and check the specific gravity of each battery cell with a hydrometer. Note the results.
- 7 Check the ambient air temperature and adjust the specific gravity reading for each cell as follows:
 - Add 0.004 to the reading of each cell for every 5.5° C above 26.7° C.
 - Subtract 0.004 from the reading of each cell for every 5.5° C below 26.7° C.
- ⊙ Result: All battery cells display an adjusted specific gravity of 1.277 or higher. The battery is fully charged. Proceed to step 11.
- ⊖ Result: One or more battery cells display a specific gravity of 1.217 or below. Proceed to step 8.
- 8 Perform an equalizing charge OR fully charge the batteries and allow the batteries to rest at least 6 hours.
- 9 Remove the battery vent caps and check the specific gravity of each battery cell with a hydrometer. Note the results.
- 10 Check the ambient air temperature and adjust the specific gravity reading for each cell as follows:
 - Add 0.004 to the reading of each cell for every 5.5° C above 26.7° C.
 - Subtract 0.004 from the reading of each cell for every 5.5° C below 26.7° C.
- ⊙ Result: All battery cells display a specific gravity of 1.277 or greater. The battery is

Maintenance

fully charged. Proceed to step 11.

- ☐ Result: The difference in specific gravity readings between cells is greater than 0.1 OR the specific gravity of one or more cells is less than 1.177. Replace the battery.
- 11 Check the battery acid level. If needed, replenish with distilled water to 3 mm below the bottom of the battery fill tube. Do not overfill.
 - 12 Install the vent caps and neutralize any electrolyte that may have spilled.

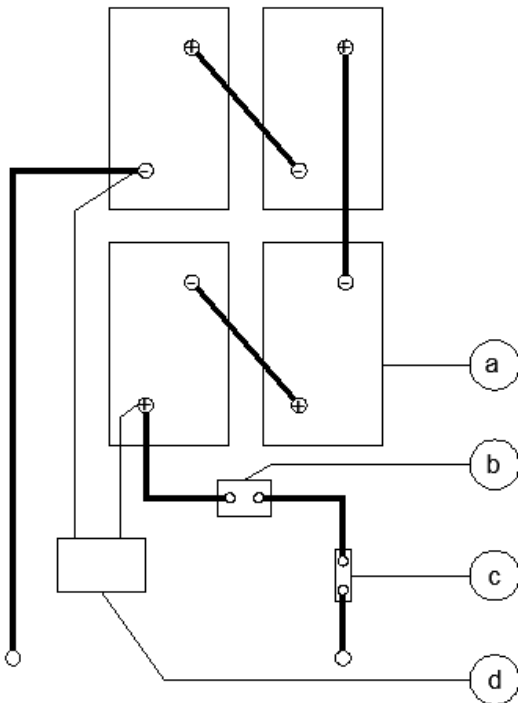

Apply to
JCPT0807/JCPT0808/JCPT1008/JCPT1012
(Hydraulic Motor / AC Motor Drive)

- a 6V batteries
- b power switch
- c fuse
- d battery charger

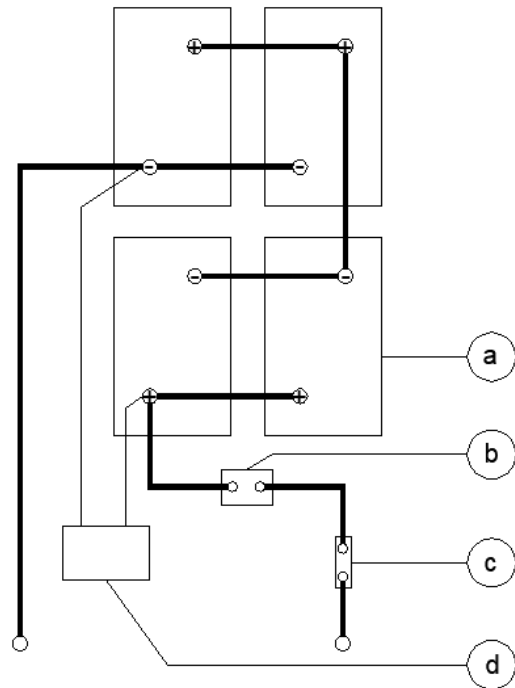

Apply to JCPT1212/JCPT1412/JCPT1614
(Hydraulic Motor / AC Motor Drive)

- a 12V batteries
- b power switch
- c fuse
- d battery charger

Suitable for lithium batteries

- 13 The connection between the electrode and the data should be fastened. There should be no dirt, metal dust or other dirt at the connection. If there is any, compressed air should be used to clean it.
- 14 Make sure the battery is reliable and stable
- 15 The battery pack should not be cracked, bulging, deformed, pole loose and other abnormal conditions.
- 16 Battery voltage, temperature and other states should also be checked before use to ensure that all values are within the normal range before starting up for use.
- 17 It is forbidden to use the battery over discharge to ensure that the cell voltage of the unit is not lower than 2V.

Maintenance

All models:

- 18 Check each battery pack and verify that the batteries are wired correctly.
 - 19 Inspect the battery charger plug and pigtail for damage or excessive insulation wear. Replace as required.
 - 20 Connect the battery charger to a properly grounded 110 - 230V / 50 – 60 Hz single phase AC power supply.
- ⊙ Result: The charger should operate and begin charging the batteries.
- ⊗ Result: If, simultaneously, the charger alarm sounds and the LEDs blink, correct the charger connections at the fuse and battery. The charger will then operate correctly and begin charging the batteries.

Note: For best results, use an extension of adequate size with a length no longer than 50 ft / 15 m.

The following must be measured and recorded once the battery has been fully charged, after a waiting time of at least 12 hours:

- Total voltage
- Individual voltage of the block battery

If significant changes to previous measurements or differences between the block batteries are identified, then customer service must be contacted for further testing or repairs.

Note: If you have any further questions regarding the battery charger operation, please contact the DINGLI Service Department.

B-2

Inspect the Electrical Wiring



DINGLI requires that this procedure be performed every 250 hours or quarterly, whichever comes first.

Maintaining electrical wiring in good condition is essential to safe operation and good machine performance. Failure to find and replace burnt, chafed, corroded or pinched wires could result in unsafe operating conditions and may cause component damage.

⚠ WARNING Electrocutation / burn hazard.

Contact with electrically charged circuits could result in death or serious injury. Remove all rings, watches and other jewelry.

- 1 Inspect the underside of the chassis for damaged or missing ground strap(s).
- 2 Inspect the following areas for burnt, chafed, corroded and loose wires:
 - Ground control panel
 - Hydraulic power unit module tray
 - Battery pack module tray
 - Platform controls
- 3 Turn the key switch to ground control. Turn the ground red Emergency Stop button clockwise to the on position. Pull out the platform red Emergency Stop button to the on position.
- 4 Raise the platform until the distance of the two sets of scissor at least 1.64 ft / 0.5m.
- 5 Lift the safety arm, move it to the center of the scissor arm and rotate up to a vertical position.

Maintenance

- 6 Lift the upper safety arm, move it to the center of the scissor arm and rotate down to a vertical position. (for JCPT1412, JCPT1614).
- 7 Lower the platform until the safety arm rests securely on the link. Keep clear of the safety arm when lowering the platform.

⚠ WARNING Crushing hazard. Keep hands clear of the safety arm when lowering the platform.

- 8 Inspect the center chassis area and scissor arms for burnt, chafed and pinched cables.
- 9 Inspect the following areas for burnt, chafed, corroded, pinched and loose wires:
 - Scissor arms
 - ECU to platform controls
 - Power to platform wiring
- 10 Inspect for a liberal coating of dielectric grease in the following locations:
 - Between the ECU and platform controls
 - All wire harness connectors Level sensor
- 11 Raise the platform and return the safety arm to the stowed position.
- 12 Lower the platform to the stowed position and turn the machine off.

B-3

Inspect the Tires and Wheels (including castle nut torque)



DINGLI requires that this procedure be performed every 250 hours or quarterly, whichever comes first.

Maintaining the tires and wheels in good condition is essential to safe operation and good performance. Tire and/or wheel failure could result in a machine tip-over. Component damage may also result if problems are not discovered and repaired in a timely fashion.

- 1 Check the tire surface and sidewalls for cuts, cracks, punctures and unusual wear.
- 2 Check each wheel for damage, bends and cracks.

For HA model machine

- 3 Remove the cotter pin and check each castle nut for proper torque.

Note: Always replace the cotter pin with a new one when removing the castle nut or when checking the torque of the castle nut.

- 4 Install a new cotter pin. Bend the cotter pin to lock it in place.

| | |
|-------------------------------|------------|
| Castle nut torque, dry | 300 ft-lbs |
| | 406.7 Nm |
| Castle nut torque, lubricated | 225 ft-lbs |
| | 305 Nm |

For AC model machine

- 3 Check each bolt for proper torque.

| | |
|-------------------------|-------------|
| Bolt torque, dry | 92.2 ft-lbs |
| | 125 Nm |
| Bolt torque, lubricated | 84.8 ft-lbs |
| | 115 Nm |

B-4**Test the Emergency Stop**

DINGLI requires that this procedure be performed every 250 hours or quarterly, whichever comes first.

A properly functioning Emergency Stop is essential for safe machine operation. An improperly operating red Emergency Stop button will fail to shut off power and stop all machine functions, resulting in a hazardous situation.

As a safety feature, selecting and operating the ground controls will override the platform controls, except the platform red Emergency Stop button.

- 1 Turn the key switch to ground control. Pull out the ground and platform red Emergency Stop button to the on position.
 - 2 Push in the red Emergency Stop button at the ground controls to the off position.
- ⊙ Result: No machine functions should operate.
- 3 Turn the key switch to platform control. Pull out the ground and platform red Emergency Stop button to the on position.
 - 4 Push in the red Emergency Stop button at the platform controls to the off position.
- ⊙ Result: No machine functions should operate.

Note: The red Emergency Stop button at the ground controls will stop all machine operation, even if the key switch is switched to platform control.

B-5**Test the Key Switch**

DINGLI requires that this procedure be performed every 250 hours or quarterly, whichever comes first.

Proper key switch action and response is essential to safe machine operation. The machine can be operated from the ground or platform controls and the activation of one or the other is accomplished with the key switch. Failure of the key switch to activate the appropriate control panel could cause a hazardous operating situation.

Perform this procedure from the ground using the platform controls. Do not stand in the platform.

- 1 Pull out the ground and platform red Emergency Stop button to the on position.
 - 2 Turn the key switch to platform control.
 - 3 Check the platform up/down function from the ground controls.
- ⊙ Result: The machine functions should not operate.
- 4 Turn the key switch to ground control.
 - 5 Check the machine functions from the platform controls.
- ⊙ Result: The machine functions should not operate.
- 6 Turn the key switch to the off position.
- ⊙ Result: No function should operate.

Maintenance

B-6

Test the Automotive-style Horn (if equipped)

DINGLI requires that this procedure be performed every 250 hours or quarterly, whichever comes first.

The horn is activated at the platform controls and sounds at the ground as a warning to ground personnel. An improperly functioning horn will prevent the operator from alerting ground personnel of hazards or unsafe conditions.

- 1 Turn the key switch to platform control. Pull out the ground and platform red Emergency Stop button to the on position.
- 2 Push down the horn button at the platform controls.

⊙ Result: The horn should sound.

B-7

Test the Drive Brakes



DINGLI requires that this procedure be performed every 250 hours or quarterly, whichever comes first.

Proper brake action is essential to safe machine operation. The drive brake function should operate smoothly, free of hesitation, jerking and unusual noise.

Hydraulically-released individual wheel brakes can appear to operate normally when not fully operational.

Perform this procedure with the machine on a firm level surface that is free of obstructions, with the platform extension deck fully retracted and the platform in the stowed position.

- 1 Mark a test line on the ground for reference.
- 2 Turn the key switch to platform control. Pull out the ground and platform red Emergency Stop button to the on position.
- 3 Lower the platform to the stowed position.
- 4 Press the drive function select button.
- 5 Choose a point on the machine; i.e., contact patch of a tire, as a visual reference for use when crossing the test line.
- 6 Bring the machine to top drive speed before reaching the test line. Release the function enable switch or the joystick when your reference point on the machine crosses the test line.
- 7 Measure the distance between the test line and your machine reference point.

⊙ Result: The machine stops within the specified braking distance. No action required.

Maintenance

- ☐ Result: The machine does not stop within the specified braking distance.

Note: The brakes must be able to hold the machine on any slope it is able to climb.

- 8 Replace the brakes and repeat this procedure beginning with step 1.

Braking distance, maximum

| | |
|-----------------------------|------------------------------|
| High range on paved surface | 24 in±11.8 in 61 cm±30 cm |
|-----------------------------|------------------------------|

B-8**Test the Drive Speed - Stowed Position**

DINGLI requires that this procedure be performed every 250 hours or quarterly, whichever comes first.

Proper drive functions are essential to safe machine operation. The drive function should respond quickly and smoothly to operator control. Drive performance should also be free of hesitation, jerking and unusual noise over the entire proportionally controlled speed range.

Perform this procedure with the machine on a firm, level surface that is free of obstructions.

- 1 Create start and finish lines by marking two lines on the ground 40 ft / 12.2 m apart.
- 2 Turn the key switch to platform control. Pull out the ground and platform red Emergency Stop button to the on position.
- 3 Lower the platform to the stowed position.
- 4 Press the drive function select button.
- 5 Choose a point on the machine; i.e., contact patch of a tire, as a visual reference for use when crossing the start and finish lines.
- 6 Bring the machine to top drive speed before reaching the start line. Begin timing when your reference point on the machine crosses the start line.
- 7 Continue at full speed and note the time when your reference point on the machine passes over the finish line. Refer to specifications.

Maintenance

B-9

Test the Drive Speed - Raised Position



DINGLI requires that this procedure be performed every 250 hours or quarterly, whichever comes first.

Proper drive functions are essential to safe machine operation. The drive function should respond quickly and smoothly to operator control. Drive performance should also be free of hesitation, jerking and unusual noise over the entire proportionally controlled speed range.

Perform this procedure with the machine on a firm, level surface that is free of obstructions.

- 1 Create start and finish lines by marking two lines on the ground 40 ft / 12.2 m apart.
- 2 Turn the key switch to platform control. Pull out the ground and platform red Emergency Stop button to the on position.
- 3 Press the lift function select button.
- 4 Press and hold the function enable switch on the joystick.
- 5 Raise the platform approximately 2 m from the ground.
- 6 Press the drive function select button.
- 7 Choose a point on the machine; i.e., contact patch of a tire, as a visual reference for use when crossing the start and finish lines.
- 8 Bring the machine to top drive speed before reaching the start line. Begin timing when your reference point on the machine crosses the start line.
- 9 Continue at full speed and note the time when your reference point on the machine passes over the finish line. Refer to specifications.

B-10

Test the Slow Drive Speed



DINGLI requires that this procedure be performed every 250 hours or quarterly, whichever comes first.

Proper drive functions are essential to safe machine operation. The drive function should respond quickly and smoothly to operator control. Drive performance should also be free of hesitation, jerking and unusual noise over the entire proportionally controlled speed range.

Perform this procedure with the machine on a firm, level surface that is free of obstructions.

- 1 Create start and finish lines by marking two lines on the ground 40 ft / 12.2 m apart.
- 2 Turn the key switch to platform control. Pull out the ground and platform red Emergency Stop button to the on position.
- 3 Lower the platform to the stowed position.
- 4 Press the slow speed select button.
- 5 Choose a point on the machine; i.e., contact patch of a tire, as a visual reference for use when crossing the start and finish lines.
- 6 Bring the machine to top drive speed before reaching the start line. Begin timing when your reference point on the machine crosses the start line.
- 7 Continue at full speed and note the time when your reference point on the machine passes over the finish line. The time is less than 25 sec.

B-11**Perform Hydraulic Oil Analysis**

DINGLI requires that this procedure be performed every 250 hours or quarterly, whichever comes first.

Replacement or testing of the hydraulic oil is essential for good machine performance and service life. Dirty oil may cause the machine to perform poorly and continued use may cause component damage. Extremely dirty conditions may require oil changes to be performed more often.

Before replacing the hydraulic oil, the oil may be tested by an oil distributor for specific levels of contamination to verify that changing the oil is necessary.

If the hydraulic oil is not replaced at the two year inspection, test the oil quarterly. Replace the oil when it fails the test. See E-1, Test or Replace the Hydraulic Oil.

B-12**Inspect the Hydraulic Tank Cap Venting System**

DINGLI requires that this procedure be performed quarterly or every 250 hours, whichever comes first. Perform this procedure more often if dusty conditions exist.

A free-breathing hydraulic tank cap is essential for good machine performance and service life. A dirty or clogged cap may cause the machine to perform poorly. Extremely dirty conditions may require that the cap be inspected more often.

- 1 Remove the breather cap from the hydraulic tank.
 - 2 Check for proper venting.
- ☉ Result: Air passes through the breather cap.
- ☒ Result: If air does not pass through the cap, clean or replace the cap. Proceed to step 3.

Note: When checking for positive tank cap venting, air should pass freely through the cap.

- 3 Using a mild solvent, carefully wash the cap venting system. Dry using low pressure compressed air. Repeat step 2.
- 4 Install the breather cap onto the hydraulic tank.

Maintenance

B-13

Check the Module Tray Latch Components



DINGLI requires that this procedure be performed every 250 hours or quarterly, whichever comes first.

Maintaining the module tray latch components in good condition is essential to good performance and service life. Failure to detect worn out latch components may result in module trays opening unexpectedly, creating an unsafe operating condition.

- 1 Inspect each module tray rotary latch and related components for wear. Tighten any loose fasteners.
- 2 Lubricate each module tray rotary latch. Using light oil, apply a few drops to each of the springs and to the sides of the rotary latch mechanism.

B-14

Test the Pothole Limit Switches and the Level Sensor



DINGLI requires that this procedure be performed every 250 hours or quarterly, whichever comes first.

Maintaining the limit switches is essential to safe operation and good machine performance. Operating the machine with a faulty limit switch could result in reduced machine performance and a potentially unsafe operating condition.

Perform these procedures with the machine on a firm, level surface that is free of obstructions.

Level sensor

- 1 Remove the platform controls from the platform.
 - 2 Turn the key switch to platform control. Pull out the ground and platform red Emergency Stop button to the on position.
 - 3 Press the drive function select button
 - 4 Move the machine onto a grade which exceeds the rating of the level sensor. Refer to the serial label on the machine.
 - 5 Press the lift function select button. Standing on the up-hill side of the machine, attempt to raise the platform to approximately 7.9 ft / 2.4 m.
- ⊙ Result: The LED readout screen shows code LL, an alarm sounds, and the machine stops lifting after the pothole guards are deployed. The machine is functioning properly.
- ⊘ Result: The LED readout screen does not show code LL, the alarm does not sound and the machine will continue to lift the platform after the pothole guards are deployed. Adjust or replace the level sensor.

Maintenance

- 6 Press the drive function select button.
Standing on the up-hill side of the machine, attempt to steer and drive the machine.

⊙ Result: The LED readout screen shows code LL, an alarm sounds, and the machine will not steer or drive. The machine is functioning properly.

⊗ Result: The LED readout screen does not show code LL, the alarm does not sound and the steer and drive functions operate. Adjust or replace the level sensor.

Pothole Limit Switches

- 7 Lower the platform to the stowed position. Move the machine onto a firm, level surface.

- 8 Place a wooden block approximately 2 in / 5 cm tall under the right pothole guard.

- 9 Press the lift function select button. Attempt to raise the platform approximately 7.9 ft / 2.4 m.

⊙ Result: The pothole guard contacts the block and does not fully deploy, the LED readout screen shows code 18, an alarm sounds and the platform will lift to 7.9 ft / 2.4 m or beyond. The machine is functioning properly.

⊗ Result: The pothole guard contacts the block and does not fully deploy, the LED readout screen does not show code 18, the alarm does not sound and the machine will continue to lift the platform after the pothole guards are deployed. Adjust or replace the pothole limit switch.

- 10 Press the drive function select button. Attempt to steer or drive the machine.

⊙ Result: The LED readout screen shows code 18, an alarm sounds, and the machine will not steer or drive. The machine is functioning properly.

⊗ Result: The LED readout screen does not show code 18, the alarm does not sound and the steer and drive functions operate. Adjust or replace the down limit switch.

- 11 Lower the platform to the stowed position and remove the block under the right pothole guard.

- 12 Repeat this procedure beginning with step 34 for the left pothole guard.

- 13 Lower the platform to the stowed position, remove the block under the left pothole guard.

- 14 Turn off the machine.

Maintenance

Checklist C Procedures

C-1

Test the Platform Overload System (if equipped)



DINGLI requires that this procedure be performed every 500 hours or six months, whichever comes first or when the machine fails to lift the maximum rated load.

Testing the platform overload system regularly is essential to safe machine operation. Continued use of an improperly operating platform overload system could result in the system not sensing an overloaded platform condition. Machine stability could be compromised resulting in the machine tipping over.

The platform overload system is designed to prevent machine operation in the event the platform is overloaded. Models equipped with the platform overload option are provided with two additional machine control components: the overload pressure sensor and the platform height sensor.

The overload pressure transducer, located at the valve of the lift cylinder, is used to determine the pressure inside the lift cylinder.

The platform height sensor, located at the steer end of the chassis, battery side, is used to determine the height of the platform.

The overload pressure transducer and the platform height sensor provide the GCON with necessary information to determine the load in the platform.

Note: The overload system will not measure loads at or below the height of the Down Limit.

Note: Perform this test from the ground with the platform controller. Do not stand in the platform.

⚠ WARNING Perform this procedure with the machine on a firm, level surface.

- 1 Turn the key switch to ground control. Pull out the ground and platform red Emergency Stop button to the on position.
- 2 Determine the maximum platform capacity.
- 3 Using a suitable lifting device, place an appropriate test weight equal to the maximum platform capacity in the center of the platform floor.
- 4 Lift the platform to the highest position.
 - ⊙ Result: The overload alarm should not sound, indicating a normal condition.
 - ⊗ Result: The overload alarm should sound. Calibrate the platform overload system.
- 5 Lower the platform to the stowed position
- 6 Add an additional weight to the platform not to exceed 20% of the maximum rated load.
- 7 Raise the platform
 - ⊙ Result: The overload alarm should sound, indicating a normal condition.
 - ⊗ Result: The overload alarm should not sound. Calibrate the platform overload system.
- 8 Test all machine functions from the ground controls.
 - ⊙ Result: All ground control functions should operate.
- 9 Turn the key switch to platform controls

Maintenance

- 10 Test all machine functions from the platform controls.
- ⊙ Result: All platform control functions should operate.
- 11 Lift the test weight off the platform floor using a suitable lifting device.
- ⊙ Result: The overload alarm should not sound, indicating a normal condition.
 - ⊖ Result: The overload alarm should sound. Calibrate the platform overload system.
- 12 Test all machine functions from the platform controls.
- ⊙ Result: All platform control functions should operate.
- 13 Turn the key switch to ground controls
- 14 Test all machine functions from the ground controls.
- ⊙ Result: All ground control functions should operate.

C-2

Replace the Hydraulic Tank Breather Cap



DINGLI requires that this procedure be performed every 500 hours or semi-annually, whichever comes first.

The hydraulic tank is a vented-type tank. The breather cap has an internal air filter that can become clogged or, over time, can deteriorate. If the breather cap is faulty or improperly installed, impurities can enter the hydraulic system which may cause component damage. Extremely dirty conditions may require that the cap be inspected more often.

- 1 Remove and discard the hydraulic tank breather cap.
- 2 Install a new cap onto the tank.

Maintenance

Checklist D Procedures

D-1

Check the Scissor Arm Wear Pads



DINGLI requires that this procedure be performed every 1000 hours or annually, whichever comes first.

Maintaining the condition of the scissor arm wear pads is essential to safe machine operation. Continued use of worn out wear pads may result in component damage and unsafe operating conditions.

Perform this procedure with the platform in the stowed position.

- 1 Measure the distance between the number one arm cross tube and the chassis deck at the ground controls side of the non-steer end of the machine.

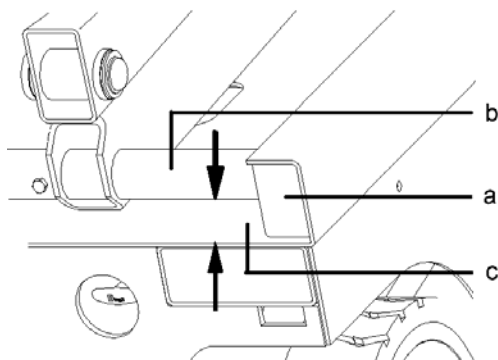

- a wear pad
- b arm cross tube
- c chassis deck

For JCPT0807HA/AC:

- ⊙ Result: The measurement is 0.9 in / 23mm or more. Proceed to step 2.
- ⊗ Result: The measurement is less than 0.9 in / 23 mm. Replace both wear pads.

For JCPT0808HA/AC~JCPT1614HA/AC:

- ⊙ Result: The measurement is 1.34 in / 34mm or more. Proceed to step 2.
 - ⊗ Result: The measurement is less than 1.34 in / 34 mm. Replace both wear pads.
- 2 Measure the distance between the number one arm cross tube and the chassis deck at the battery pack side of the non-steer end of the machine.

For JCPT0807HA/AC:

- ⊙ Result: The measurement is 0.9 in / 23mm or more. Proceed to step 2.
- ⊗ Result: The measurement is less than 0.9 in / 23 mm. Replace both wear pads.

For JCPT0808HA/AC~JCPT1614HA/AC:

- ⊙ Result: The measurement is 1.34 in / 34mm or more. Proceed to step 2.
 - ⊗ Result: The measurement is less than 1.34 in / 34 mm. Replace both wear pads.
- 3 Apply a thin layer of dry film lubricant to the area of the chassis where the scissor arm wear pads make contact.

D-2**Replace the Hydraulic Tank Return Filter Element**

DINGLI requires that this procedure be performed every 1000 hours or annually, whichever comes first.

Replacement of the hydraulic tank return filter is essential for good machine performance and service life. A dirty or clogged filter may cause the machine to perform poorly and continued use may cause component damage. Extremely dirty conditions may require that the filter be replaced more often.

CAUTION Beware of hot oil. Contact with hot oil may cause severe burns.

NOTICE The hydraulic tank return filter is mounted on the bracket between the function manifold and the hydraulic power unit.

- 1 Clean the area around the oil filter.
Remove the filter with an oil filter wrench.
- 2 Apply a thin layer of oil to the new oil filter gasket.
- 3 Install the new filter and tighten it securely by hand.
- 4 Use a permanent ink marker to write the date and number of hours from the hour meter onto the filter.
- 5 Turn the key switch to ground control. Pull out the platform and ground red Emergency Stop button to the on position.
- 6 Activate and hold the platform up toggle switch.
- 7 Inspect the filter and related components to be sure that there are no leaks.
- 8 Clean up any oil that may have spilled.

Maintenance

Checklist E Procedure

E-1

Test or Replace the Hydraulic Oil



DINGLI requires that this procedure be performed every 2000 hours or every two years, whichever comes first.

Replacement or testing of the hydraulic oil is essential for good machine performance and service life. Dirty oil may cause the machine to perform poorly and continued use may cause component damage. Extremely dirty conditions may require oil changes to be performed more often.

Before replacing the hydraulic oil, the oil may be tested by an oil distributor for specific levels of contamination to verify that changing the oil is necessary.

If the hydraulic oil is not replaced at the two year inspection, test the oil quarterly. Replace the oil when it fails the test.

Note: Perform this procedure with the platform in the stowed position.

- 1 Disconnect the battery pack from the machine.

⚠ WARNING Electrocutation / burn hazard: Contact with electrically charged circuits could result in death or serious injury. Remove all rings, watches and other jewelry.

- 2 Open the power unit module tray.
- 3 Remove the oil drain plug at bottom.
- 4 Drain all of the oil into a suitable container.
- 5 Tag and disconnect the hydraulic tank return line from the hydraulic filter head and remove the line from the tank. Cap the fitting on the filter head.

- 6 Tag and disconnect the hydraulic pump inlet line and remove the line from the tank. Cap the fitting on the pump.
- 7 Remove the hydraulic tank retaining fasteners and remove the hydraulic tank from the machine.

⚠ WARNING Bodily injury hazard.

Spraying hydraulic oil can penetrate and burn skin. Loosen hydraulic connections very slowly to allow the oil pressure to dissipate gradually. Do not allow oil to squirt or spray.

- 8 Clean up any oil that may have spilled. Properly discard the used oil.
- 9 Clean the inside of the hydraulic tank using a mild solvent. Allow the tank to dry completely.
- 10 Install a new filter onto the tank.
- 11 Tighten the drain plug. Torque to specification.

Torque specifications

| | |
|---------------------------------------|---------------------|
| Hydraulic tank drain plug, dry | 10 in-lbs 4.5 Nm |
| Hydraulic tank drain plug, lubricated | 30 in-lbs 3.4 Nm |

- 12 Install the hydraulic tank and install and tighten the hydraulic tank retaining fasteners. Torque to specification.

Torque specifications

| | |
|---|-------------------|
| Hydraulic tank retaining fasteners, dry | 35 in-lbs 4 Nm |
|---|-------------------|

Maintenance

| | |
|--|---------------------|
| Hydraulic tank drain plug, lubricated | 26 in-lbs 2.9 Nm |
|--|---------------------|

- 13 Install the hydraulic pump inlet line into the tank. Install the fitting onto the pump and torque.
- 14 Install the hydraulic pump return line into the tank. Install the fitting onto the hydraulic filter head and torque.
- 15 Fill the tank with hydraulic oil until the fluid is full in the hydraulic tank. Do not overfill.
- 16 Activate the pump to fill the hydraulic system with oil and bleed the system of air.

⚠ WARNING Component damage hazard.
The pump can be damaged if operated without oil. Be careful not to empty the hydraulic tank while in the process of filling the hydraulic system. Do not allow the pump to cavitate.

Schematic

Hydraulic Schematic

JCPT0807HA

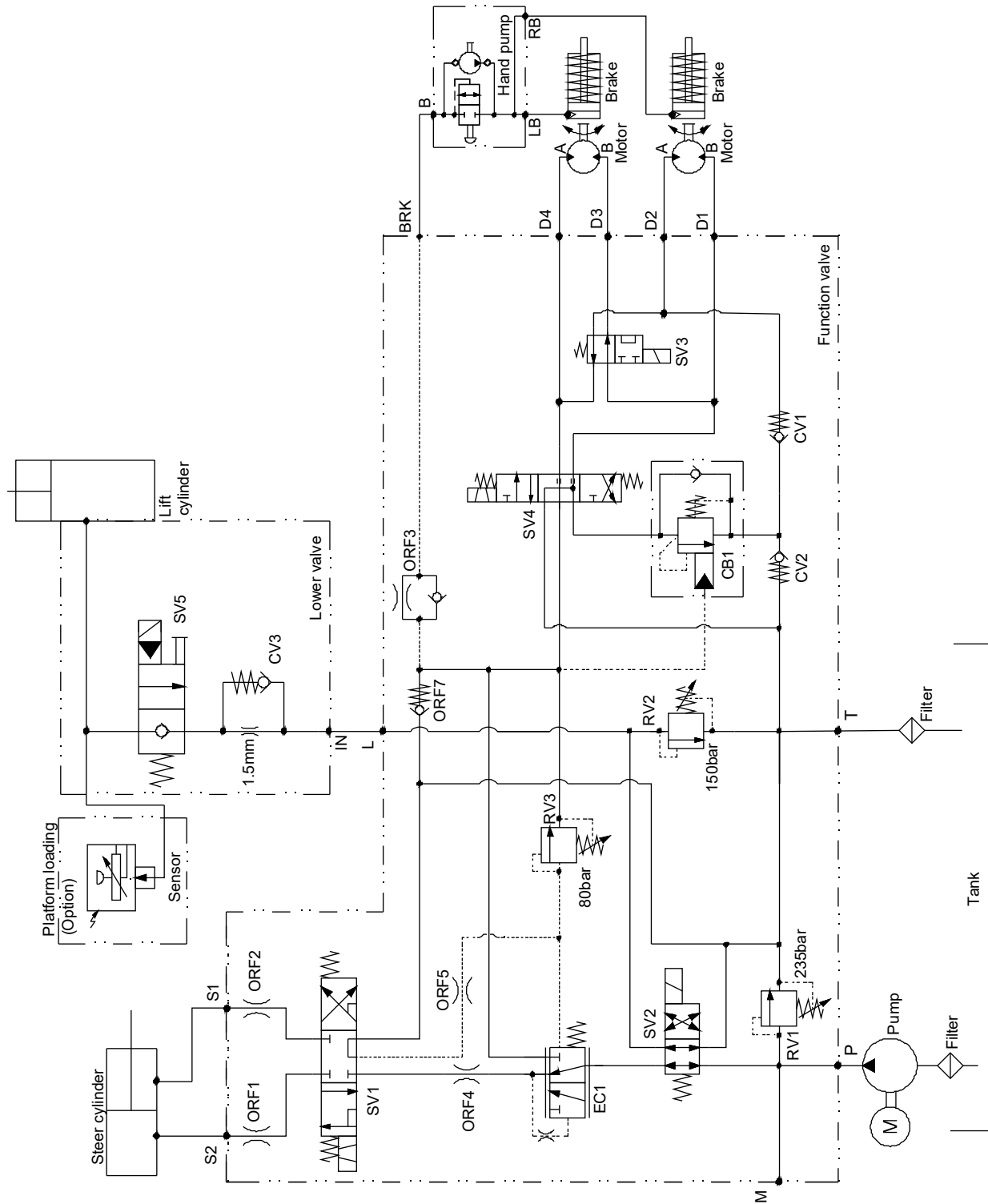

Schematic

JCPT0808HA JCPT1008HA JCPT1012HA

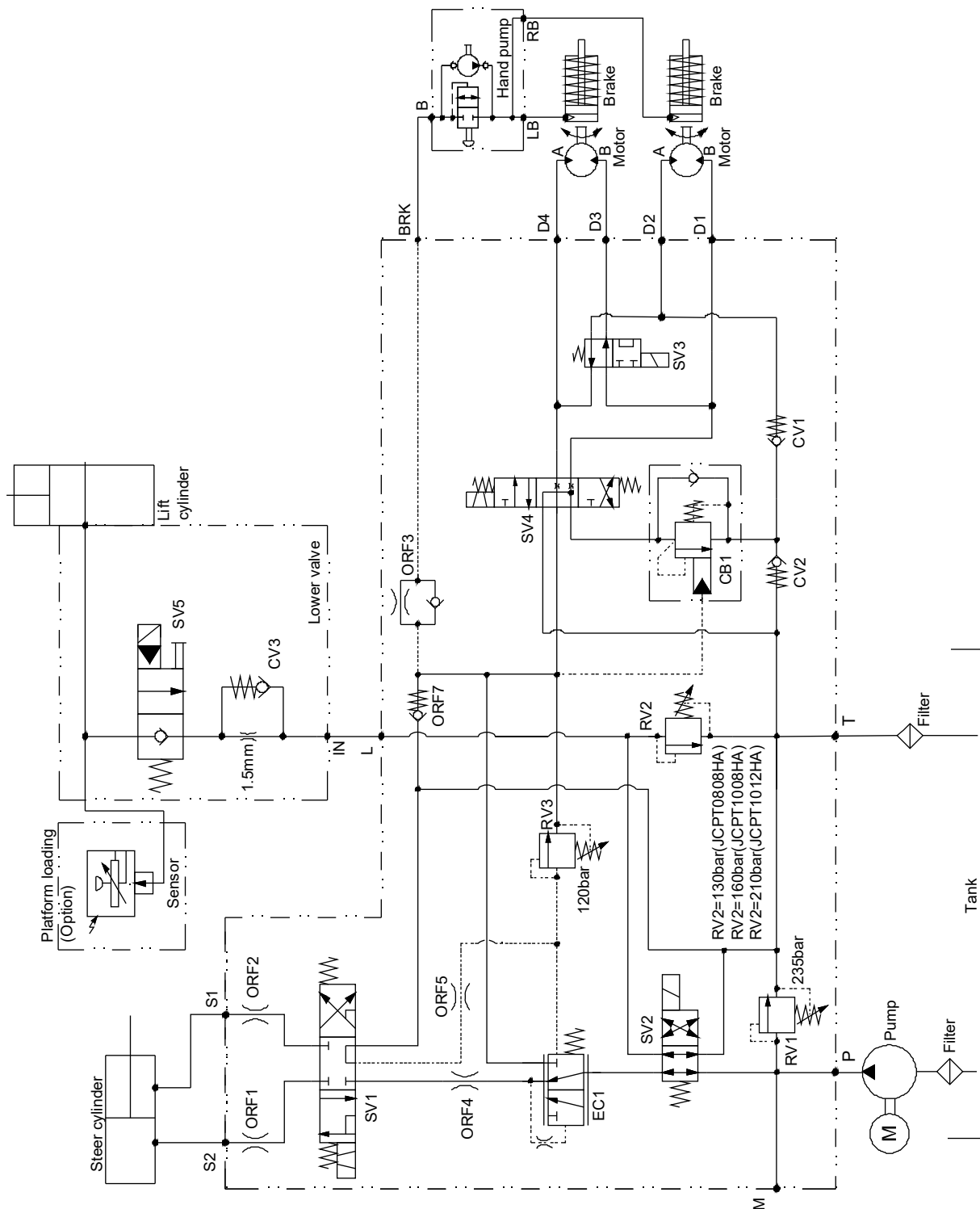

Schematic

JCPT1212HA JCPT1412HA JCPT1614HA

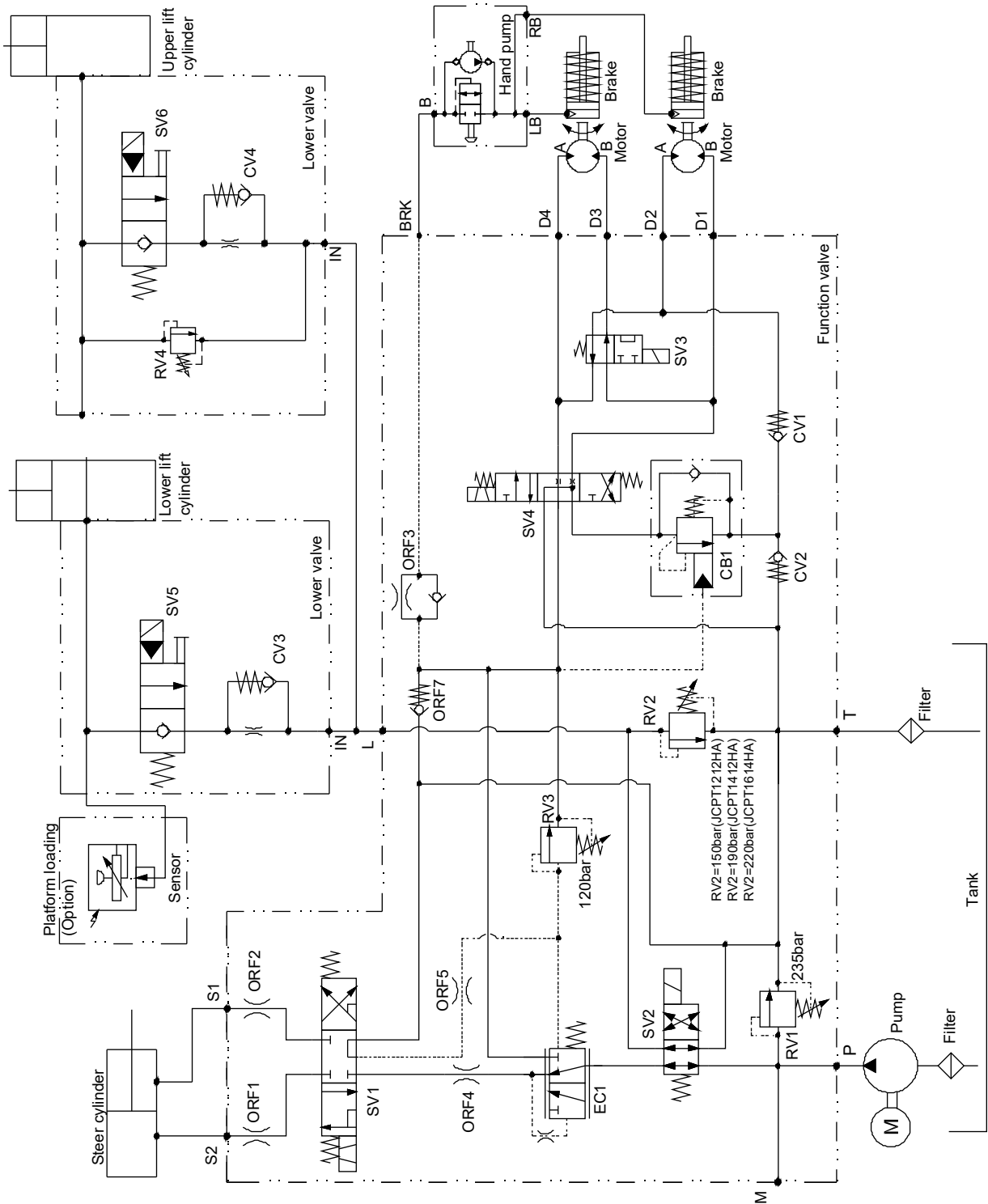

Schematic

JCPT0807AC

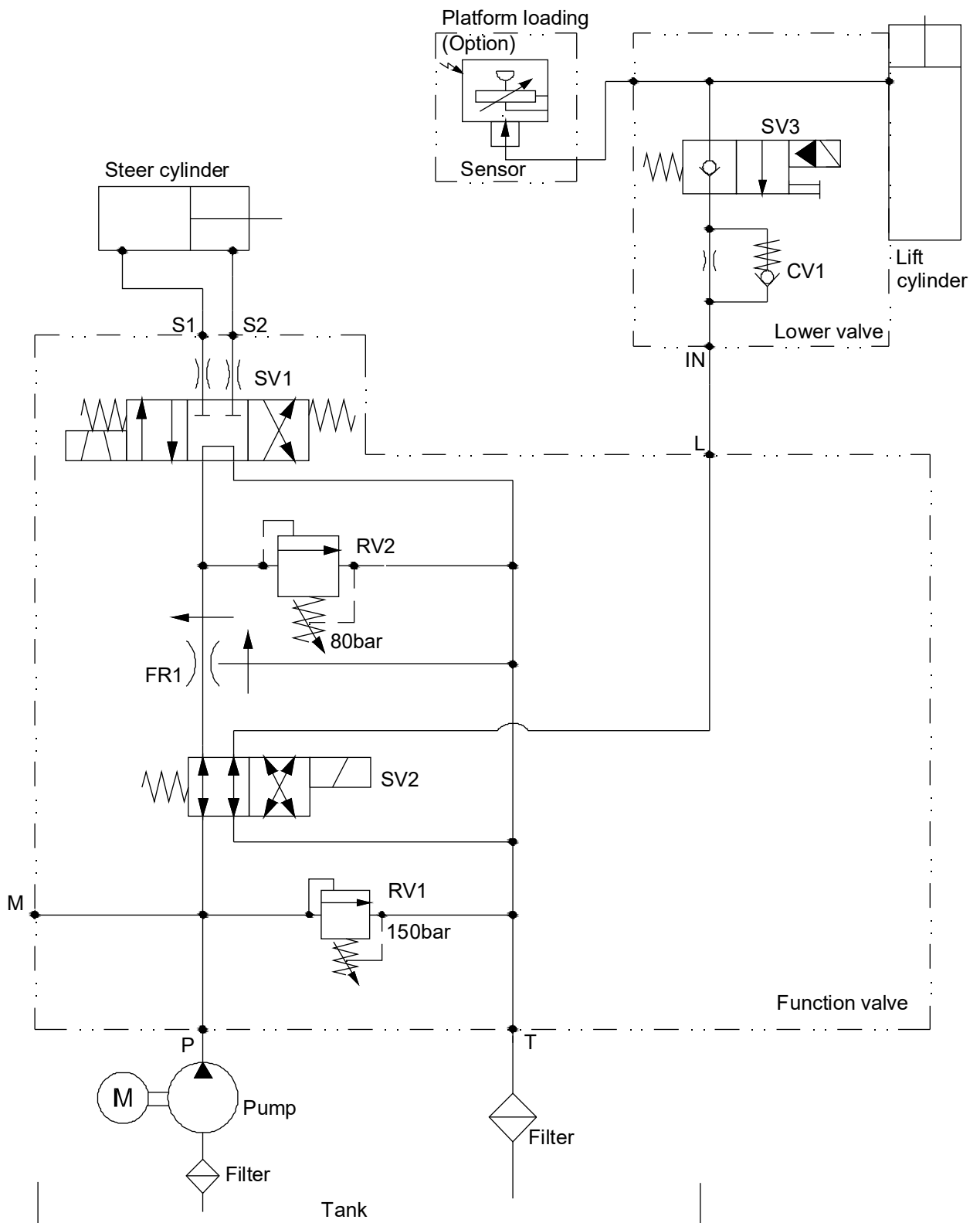

Schematic

JCPT0808AC JCPT1008AC JCPT1012AC

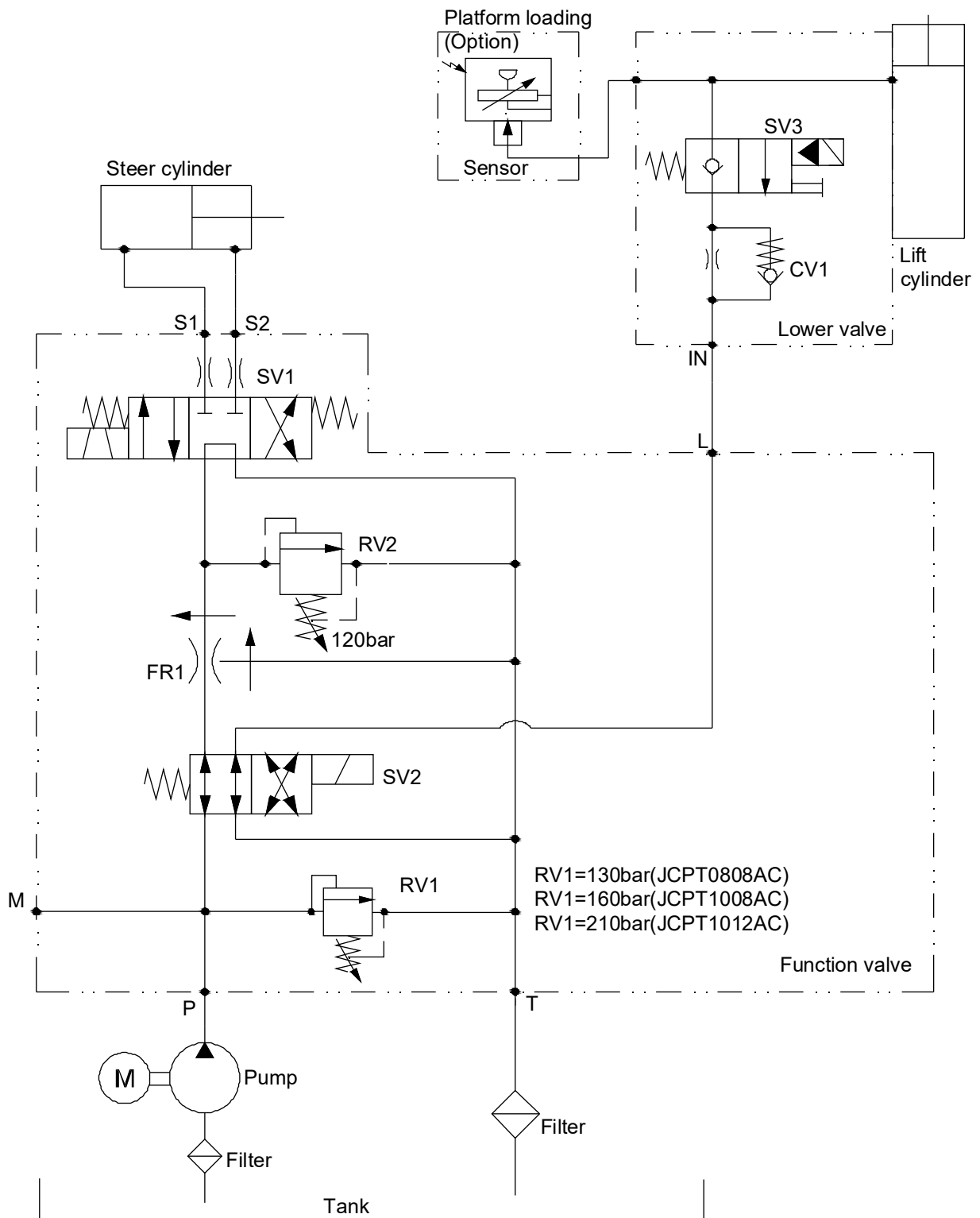

Schematic

JCPT1212AC JCPT1412AC JCPT1614AC

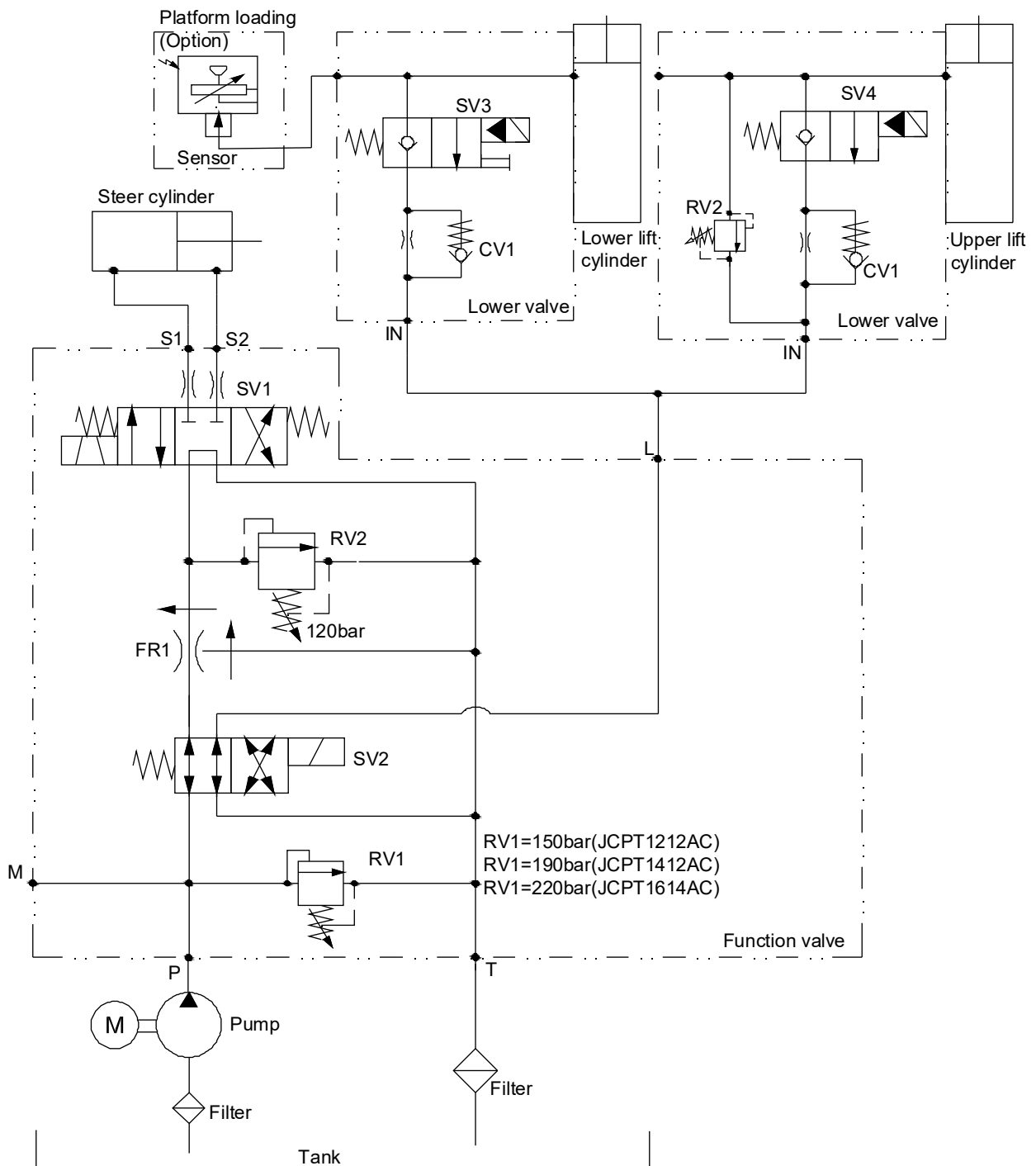

Schematic

Electrical Schematic

JCPT0807HA (Lead-acid battery)

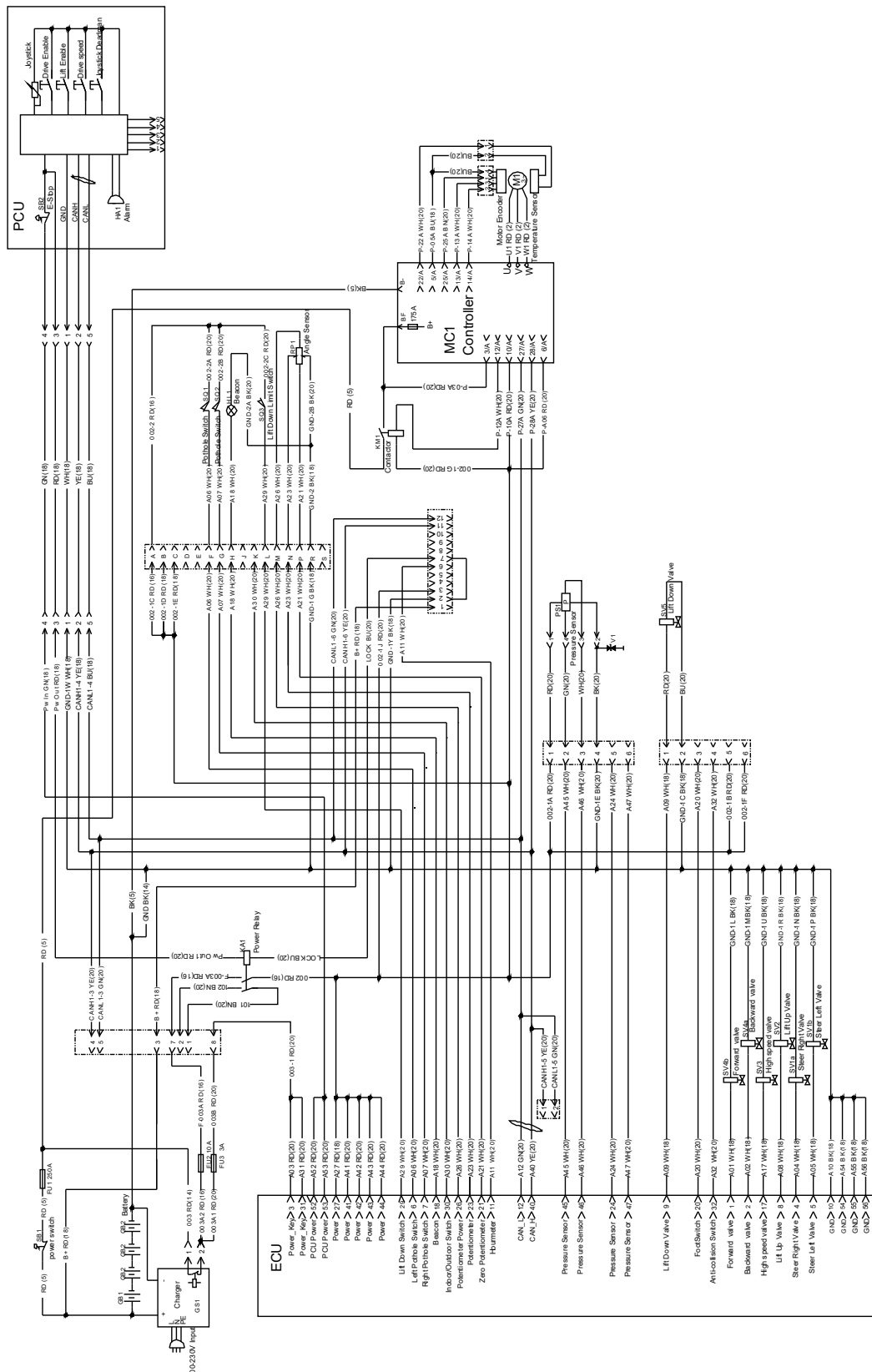

Electrical Schematic

JCPT0808HA~JCPT1614HA (Lead-acid battery)

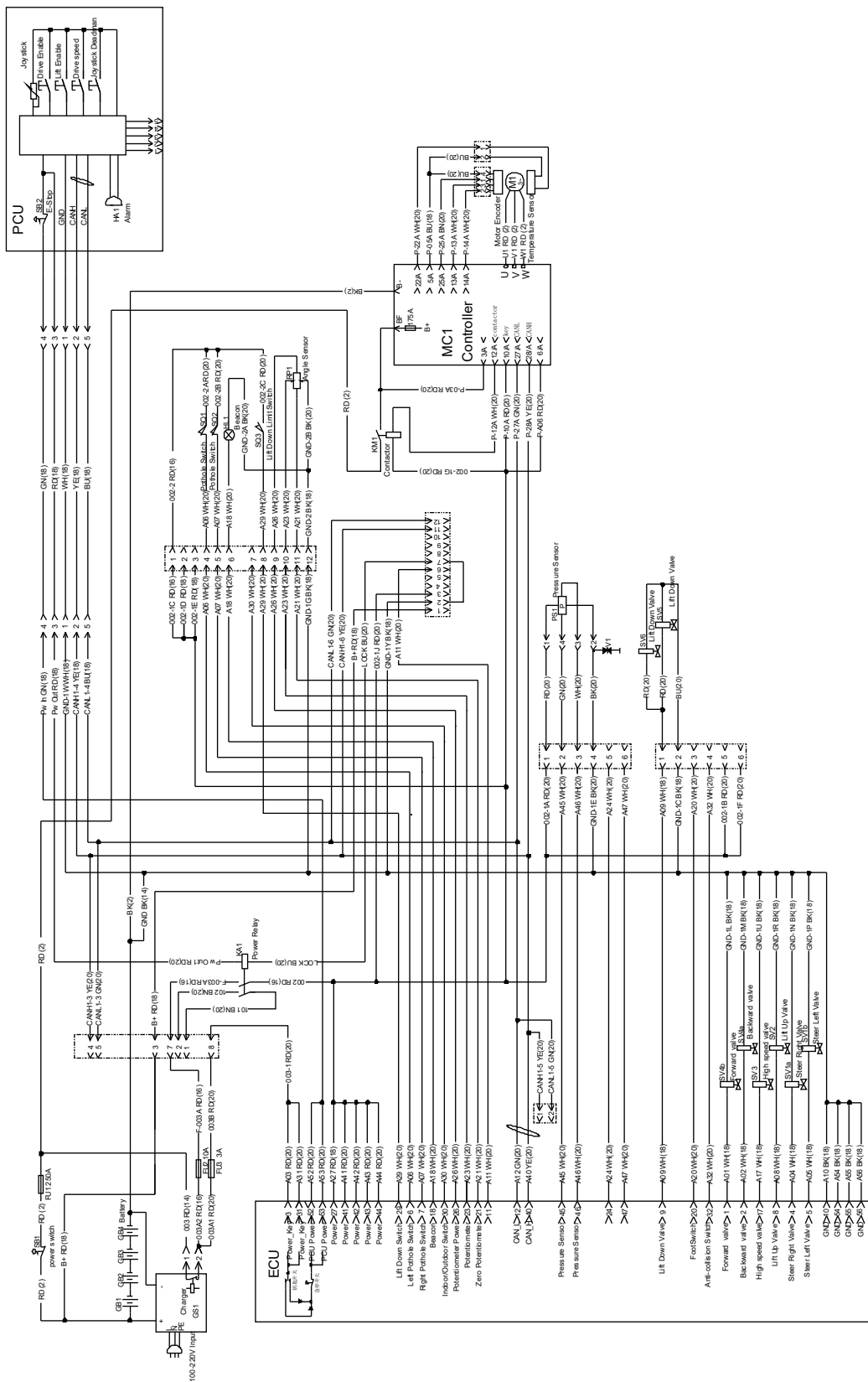

Schematic

Electrical Schematic

JCPT0807HA (Lithium battery)

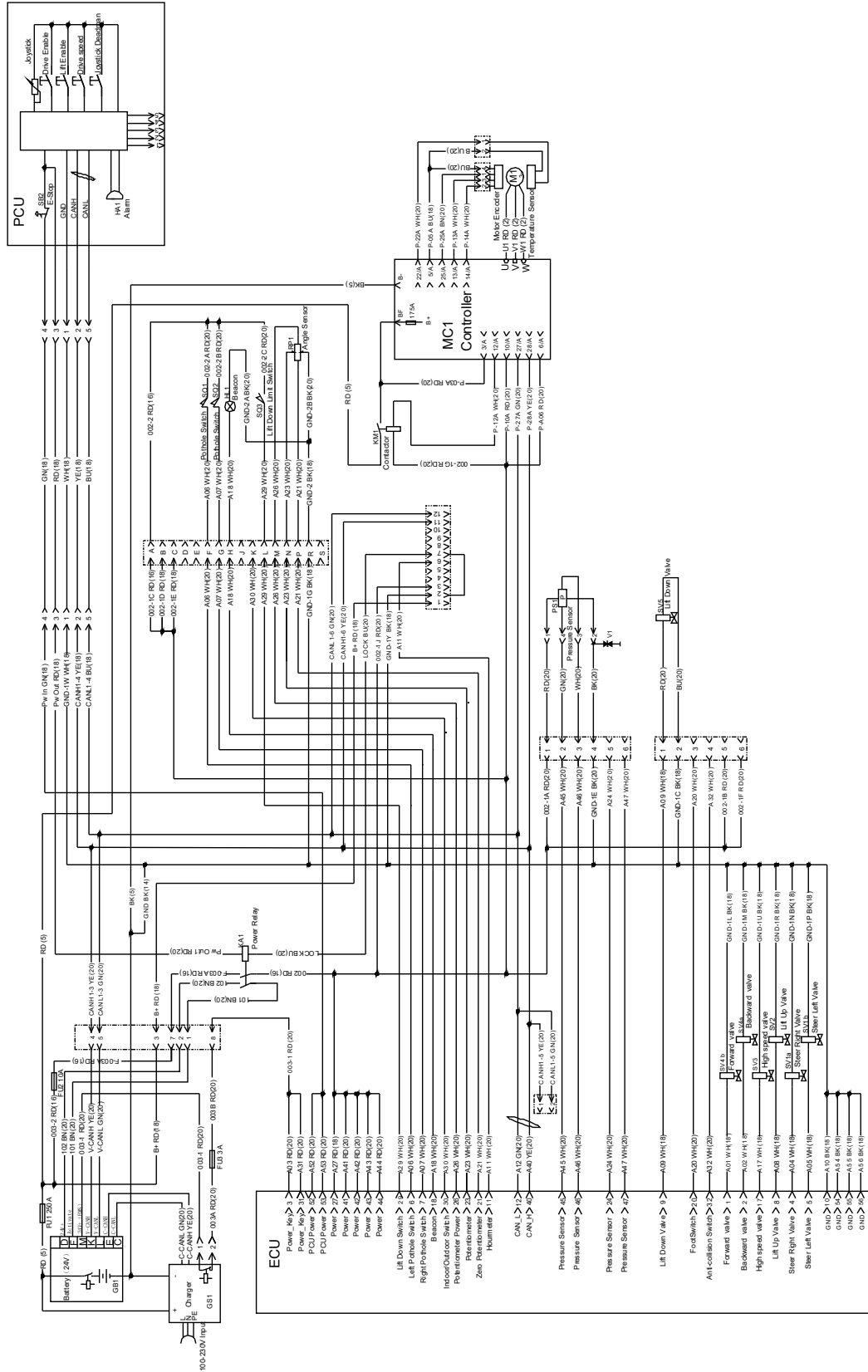

Electrical Schematic

JCPT0808AC~JCPT1614AC (Lead-acid battery)

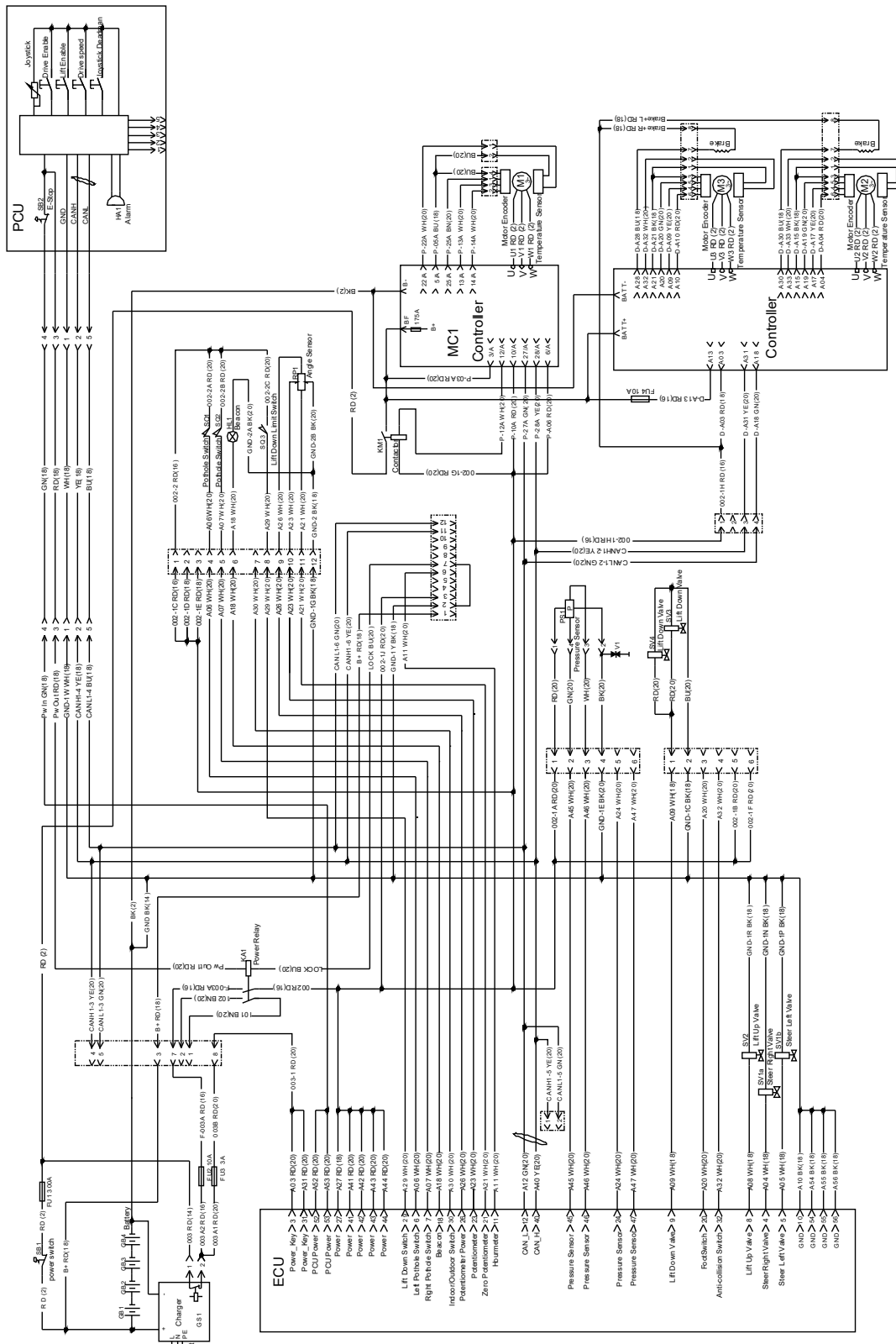

Schematic

Electrical Schematic

JCPT0807AC (Lithium battery)

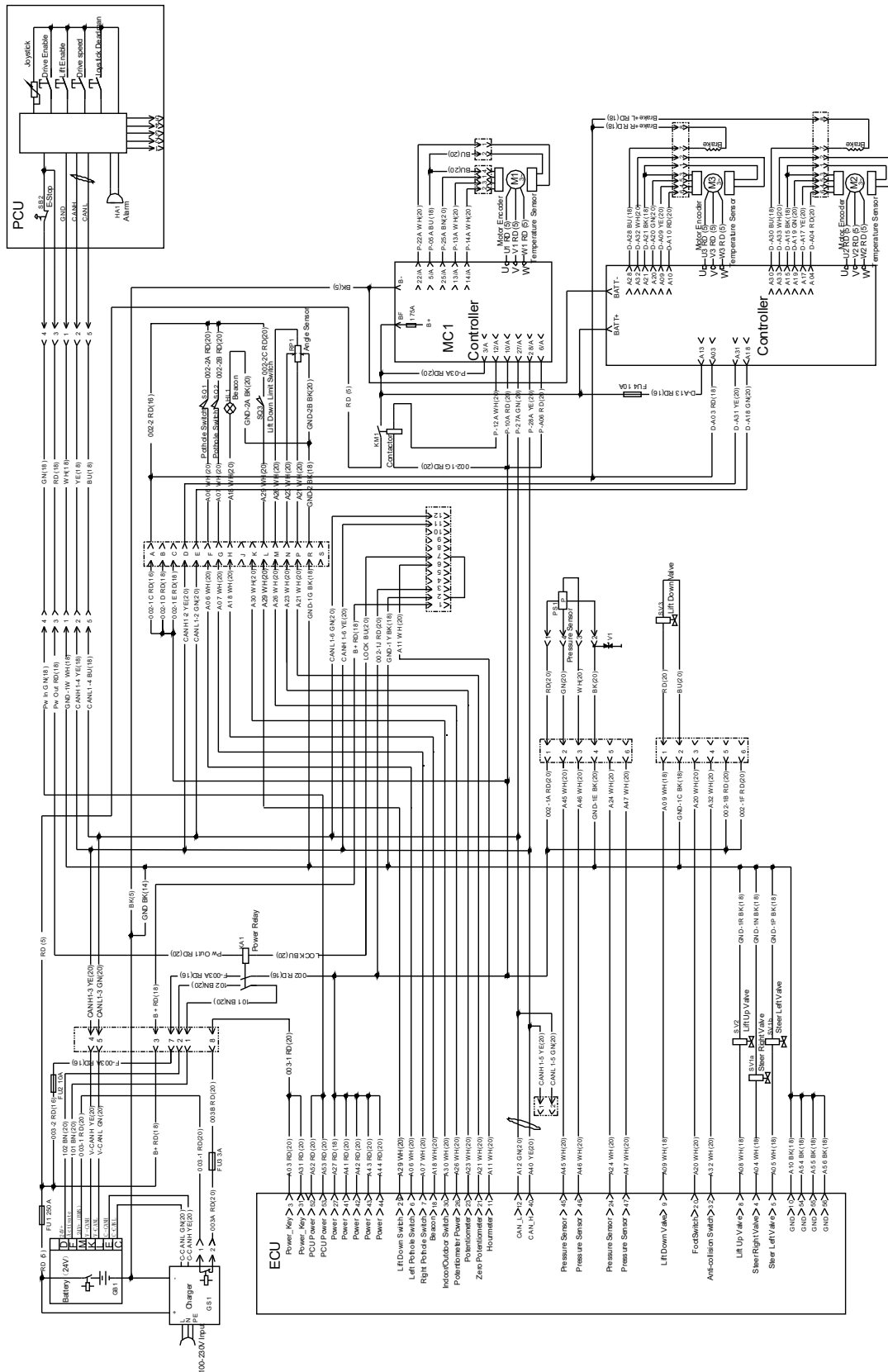

Electrical Schematic

JCPT0808AC~JCPT1614AC(Lithium battery)

