

**TELESCOPIC HANDLERS**

**Operator's manual**

TELESCOPIC HANDLERS

HTL 4014 (HTL 9045)

HTL 4017 (HTL 9055)

HTL 3614 (HTL 8045)

HTL 3617 (HTL 8055)

4000328300

E02.17

USA





<b>1 - Operator's manual</b> .....	<b>8</b>
<b>2 - After Sales Service</b> .....	<b>8</b>
<b>3 - Compliance</b> .....	<b>9</b>
<b>4 - HAULOTTE Services® contact details</b> .....	<b>10</b>

## A

### SAFETY PRECAUTIONS

<b>1 - Recommendations</b> .....	<b>11</b>
1.1- Operator's manual .....	11
1.2- Symbols used.....	11
1.3- Label colors .....	12
1.4- Symbol and hazard pictorials definitions.....	13
1.4.1 - Hazard Pictorial Descriptions .....	13
<b>2 - Work area safety</b> .....	<b>15</b>
2.1- Overturning hazards .....	15
2.2- Travelling on slopes.....	17
2.3- Fall hazards.....	18
2.4- Collision hazards.....	19
2.5- Falling object hazards.....	19
2.6- Bodily injury hazard .....	20
2.7- Damaged machine hazards .....	20
2.8- Component damage hazards .....	21
2.9- Crush hazards .....	21
2.10- Burn hazards .....	21
2.11- Explosion and fire hazards .....	22
2.12- Electrocution hazards.....	23
2.13- Battery safety .....	24
2.13.1 - Burn hazards.....	24
2.13.2 - Explosion hazard.....	24
2.13.3 - Electrocution hazard.....	24

## B

### INTERVENOR'S RESPONSIBILITY

<b>1 - Owner's (or hirer's) responsibility</b> .....	<b>25</b>
<b>2 - Employer's responsibility</b> .....	<b>25</b>
<b>3 - Trainer's responsibility</b> .....	<b>25</b>
<b>4 - Operator's responsibility</b> .....	<b>25</b>
<b>5 - Inspection and maintenance</b> .....	<b>26</b>

# CONTENTS



# C

## PRE-OPERATION AND CONTROLS

<b>1 - Checks before use</b> .....	<b>27</b>
1.1- General mechanical functions.....	27
<b>2 - Pre-operation checks and inspection</b> .....	<b>29</b>
<b>3 - Safety stickers</b> .....	<b>33</b>
3.1- Identification.....	33
3.2- Operator's cab.....	49
3.2.1 - Controls.....	49
3.2.2 - Pedals.....	51
3.2.3 - Steering column.....	52
3.2.3.1 - Steering column adjustment.....	53
3.2.4 - Operator's seat.....	54
3.2.5 - Heating and ventilation.....	55
3.2.6 - Air-conditioning(Optional).....	56
3.2.7 - Instrument/control panel.....	57
3.2.8 - Joystick.....	64
3.2.9 - Left-hand control panel.....	65
3.2.10 - Load moment indicator (LLMI).....	67
3.2.11 - Rear-view mirrors and windows.....	69
3.3- Radio-control emitter.....	72
3.3.1 - Safety devices.....	73
3.3.1.1 - Activation of controls.....	73
3.3.1.2 - Detection of internal fault.....	73
3.3.1.3 - Overload.....	73

# D

## OPERATION

<b>1 - Engine</b> .....	<b>75</b>
1.1- Starting the engine.....	75
1.2- Operational checks.....	76
1.2.1 - During the warm-up period.....	76
1.2.2 - When the engine is running.....	76
1.3- Starting the engine with a booster battery.....	76
1.4- Normal engine operation.....	77
1.5- Engine shut-down procedure.....	77
1.6- Parking brake operation.....	77
<b>2 - Operation with a load</b> .....	<b>78</b>
2.1- Load lifting safety.....	78
2.2- Before lifting a load.....	78
2.2.1 - For operation with non-suspended load.....	78
2.2.2 - For operation with suspended load.....	78
2.3- Transporting the load.....	79
2.3.1 - For operation with non-suspended load.....	79
2.3.2 - For operation with suspended load.....	79
2.4- Dumping procedure.....	80
2.5- Placing the load.....	80
2.6- Disengaging the load.....	80
<b>3 - Road operation</b> .....	<b>81</b>
<b>4 - Loading and securing for transport</b> .....	<b>82</b>



## E

### ATTACHMENTS

<b>1 - Approved attachments</b> .....	<b>85</b>
<b>2 - Unapproved attachments</b> .....	<b>85</b>
<b>3 - Telehandler/Attachment/Fork capacities</b> .....	<b>86</b>
<b>4 - Using the capacity chart with forks</b> .....	<b>88</b>
<b>5 - Attachment installation</b> .....	<b>94</b>
5.1- Mechanical attachment locking device .....	94
5.2- Hydraulic accessory locking device (Option).....	95
5.2.1 - Specific instructions .....	95
5.2.2 - Operation .....	95
5.3- Adjusting/Moving forks .....	96
<b>6 - Attachments</b> .....	<b>97</b>
6.1- Technical characteristics of the accessories .....	97
6.2- Operation .....	103
6.2.1 - Accessory control .....	103
6.2.2 - Attachment installation procedure .....	103
6.2.3 - Using the load capacity chart .....	103
6.2.4 - Operation .....	103

## F

### EMERGENCY PROCEDURE

<b>1 - Towing a broken-down vehicle</b> .....	<b>105</b>
1.1- General precautions .....	105
1.2- Releasing the axle brake for towing .....	106
1.2.1 - Parking brake deactivation .....	106
1.2.2 - Parking brake reactivation .....	106
<b>2 - Emergency boom lowering</b> .....	<b>107</b>
2.1- Manual boom lowering (emergency mode) .....	107
<b>3 - Emergency exit from cab</b> .....	<b>108</b>

## G

### TECHNICAL CHARACTERISTICS

<b>1 - Main characteristics</b> .....	<b>109</b>
1.1- Technical characteristics .....	109
1.2- Standard equipment .....	112
1.3- Optional equipment .....	113
1.3.1 - Slings attached 3T (6,615 lb) .....	113
1.3.1.1 - Main components .....	113
1.3.1.2 - Characteristics .....	113
1.3.1.3 - Control .....	114
1.3.1.4 - Operation .....	114
1.3.1.5 - Lubrication and maintenance .....	114
<b>2 - Overall dimensions</b> .....	<b>115</b>
<b>3 - Working area</b> .....	<b>117</b>
3.1- Machine HTL 9055 .....	117
3.2- Machine HTL 9045 .....	117
3.3- Machine HTL 8055 .....	118
3.4- Machine HTL 8045 .....	118
<b>4 - Noise emission level</b> .....	<b>119</b>
<b>5 - Telehandler vibration</b> .....	<b>120</b>

# CONTENTS



# H

## LUBRICATION AND MAINTENANCE

<b>1 - Maintenance guidelines</b> .....	<b>121</b>
<b>2 - Maintenance instructions</b> .....	<b>122</b>
<b>3 - Repairs and adjustments</b> .....	<b>127</b>
<b>4 - Lubrication and maintenance schedule</b> .....	<b>128</b>
<b>5 - General program / Recommendations</b> .....	<b>134</b>
<b>6 - Detailed program</b> .....	<b>138</b>
<b>7 - General points</b> .....	<b>163</b>
7.1- Mechanical .....	163
7.1.1 - Bolts and Tightening torques .....	163
7.1.2 - Pins and bearings .....	163
7.1.3 - Bearings .....	165
7.2- Hydraulics .....	166
7.2.1 - Replacing damaged of hoses .....	166
7.2.2 - Evaluation of leaks on hydraulic cylinders .....	167
7.3- Electric .....	168
7.3.1 - Replacing damaged cables .....	168
<b>8 - Every day or every 10 h of operation</b> .....	<b>169</b>
8.1- General checks .....	169
8.2- Load moment indicator .....	170
8.2.1 - Test procedure .....	170
8.2.2 - Checking procedure .....	170
8.2.3 - Resetting procedure .....	171
8.3- Diesel circuit .....	171
8.4- Cooling system .....	172
8.5- Air filter (system) .....	172
8.6- Internal combustion engine .....	174
8.7- Hydraulic circuit .....	174
8.8- Air-conditioning (Option) .....	174
<b>9 - After the first 50 hours of operation</b> .....	<b>175</b>
9.1- Chain tension check and adjustment .....	175
9.1.1 - Chain tension check .....	175
9.1.2 - Boom chain tension adjustment .....	175
<b>10 - Every 50 h hours of operation</b> .....	<b>176</b>
<b>11 - Every 100 h hours of operation</b> .....	<b>177</b>
11.1- Tyres .....	177
11.2- Diesel circuit .....	177
11.3- Internal combustion engine .....	177
11.4- Lubricating the front axle .....	178
11.5- Lubricating the rear axles .....	178
11.6- Hydraulic circuit .....	179
11.7- Air-conditioning (Option) .....	179
<b>12 - Every 250 h hours of operation</b> .....	<b>180</b>
12.1- Cooling system .....	180
12.2- Travel axles .....	180
12.3- Battery .....	180
12.4- Air-conditioning (Option) .....	180

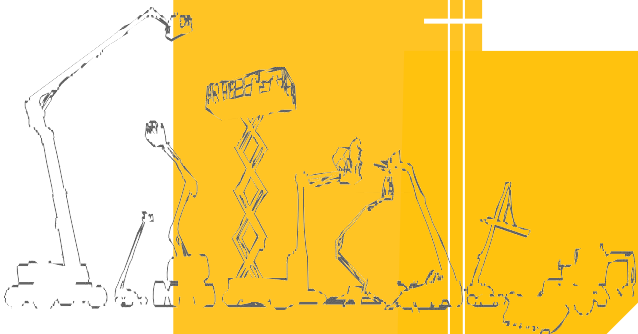

## CONTENTS

<b>13 - Every 500 h hours of operation .....</b>	<b>181</b>
13.1- Lubricating the suspension and the driver seat rails .....	181
13.2- Air filter (system) (For machines fitted with engine PERKINS 854E-34TA or KOHLER KDI 3404 TCR only) .....	181
13.3- Diesel circuit (For machines fitted with engine PERKINS 854E-34TA or PERKINS 1104D44T only) .....	181
13.3.1 - Changing the diesel filter .....	181
13.3.2 - Changing the diesel pre-filter .....	181
13.4- Internal combustion engine .....	182
13.5- Engine oil service reset .....	183
13.6- Travel axles .....	183
13.6.1 - Checking the level of the front axle .....	183
13.6.2 - Checking the level of the rear axle .....	184
13.6.3 - Checking the level of the epicycloidal reducers .....	185
<b>14 - Every 1000 h hours of operation (or once a year) .....</b>	<b>186</b>
14.1- Chain wear .....	186
14.2- Primary air filter .....	186
14.3- Internal combustion engine .....	186
14.4- Hydraulic circuit .....	187
14.4.1 - Equipment hydraulic circuit .....	187
14.4.2 - Transmission hydraulic circuit .....	187
14.5- Accumulators .....	187
14.6- Travel axles .....	188
14.6.1 - Draining the front axle .....	188
14.6.2 - Draining the rear axle .....	189
14.6.3 - Draining the epicycloidal reducers .....	190
<b>15 - Every 1500 h hours of operation .....</b>	<b>191</b>
15.1- Engine crankcase breather (Engine PERKINS 854E-34TA) .....	191
15.1.1 - Remove the breather element .....	191
15.1.2 - Install the breather element .....	192
<b>16 - Every 2000 h hours of operation (or every 2 years) .</b>	<b>193</b>
16.1- Cooling system (Engine PERKINS 1104D44T) .....	193
16.2- Air filter (system) .....	194
16.3- Internal combustion engine (Engine PERKINS 1104D44T) .....	194
16.4- Hydraulic circuit .....	195
16.5- Air-conditioning (Option) .....	196
<b>17 - Every 3000 h hours of operation (or every 3 years) .</b>	<b>197</b>
17.1- Internal combustion engine (Engine PERKINS 854E-34TA) .....	197
17.2- Diesel particulate filter (Engine PERKINS 854E-34TA) .....	197
17.3- Cooling system (For machines fitted with engine PERKINS 854E-34TA or KOHLER KDI 3404 TCR only) .....	198
<b>18 - Every 5000 h hours of operation (or every 5 years) .</b>	<b>199</b>
18.1- Internal combustion engine (Engine KOHLER KDI 3404 TCR) ....	199
<b>19 - Every 10 years .....</b>	<b>199</b>
19.1- Replacement of the brake circuit accumulators .....	199
19.1.1 - Parking brake .....	199
19.1.2 - Service brake .....	199
19.2- Lubricants and equivalents .....	200
<b>20 - Electric circuit .....</b>	<b>203</b>
20.1- Wiring diagram-Main components .....	203
<b>21 - Hydraulic circuit .....</b>	<b>204</b>
21.1- Hydraulic diagram-Main components .....	204
<b>22 - Troubleshooting .....</b>	<b>205</b>
22.1- Procedure .....	207

## INTERVENTION REGISTER

<b>1 - Intervention register .....</b>	<b>209</b>
--	------------

# You have just purchased a HAULOTTE® product and we would like to thank you for your business.

## 1 - Operator's manual

As stated on the delivery slip, this manual is one of the documents in the on-board document holder provided upon delivery of your HAULOTTE® machine.

The operator manual is a translation of the original instructions.

Safe operation of this product can only be assured if you follow the operating instructions contained in this manual.

We would particularly like to draw your attention to 2 essential points :

- Compliance with safety instruction (machine, use, environment)
- Use of the equipment within the performance limits.



**With regard to the designation of our equipment, we stress that this is purely for commercial purposes and not to be confused with the technical characteristics. Only the tables of technical characteristics should be used to study the suitability of the equipment for the intended use.**

## 2 - After Sales Service

Our HAULOTTE Services® After Sales Service is at your disposal throughout your machine's service life to ensure optimal use of your HAULOTTE product..

- When contacting our After Sales Service, ensure that you provide the machine model and serial number.
- When ordering any consumables or spare parts, please use this manual and the Haulotte Essential catalogue to receive your genuine HAULOTTE spare parts, your only guarantee of parts interchangeability and correct machine operation..
- If there is an equipment malfunction involving a HAULOTTE® product, then contact HAULOTTE Services® immediately even if the malfunction does not involve material and/or bodily damage..
- HAULOTTE® must be informed in the event of an incident that either involves one of these products or has caused bodily injury or significant deterioration of property (personal property or the product); contact HAULOTTE Services® immediately (See : HAULOTTE Services® contact details)

### 3 - Compliance

We would like to remind you that HAULOTTE® complies with the provisions of any applicable directives applicable to this type of machine.

HAULOTTE advises you that NO modifications carried out without the written permission of HAULOTTE® can affect the visibility in driving position and will void the HAULOTTE warranty.

Many aspects of the Telehandler testing and operation are discussed in standards published by the American National Standards Institute and the Industrial Truck Standards Development Foundation. These standards are updated on a regular basis with addenda. HAULOTTE® recommends that you purchase and refer to the following standards.

ANSI/ITSDF B56.6 - S26271\_1;

This standard can be downloaded from : [www.ITSDF.org](http://www.ITSDF.org)

ITSDF

1750 K Street NW

Site 460

Washington DC 20006

A variable reach rough terrain forklift truck is defined as a wheeled type truck with a pivoting boom, which may be equipped with various attachments for picking, transporting, and placing loads within the established load range charts.

HAULOTTE® cannot be held liable for any changes to the technical specifications contained in this manual.

HAULOTTE® reserves the right to alter technical specifications and to make improvements or modifications to the machine without modifying this manual.



**Certain options can modify the machine's operating characteristics and its associated safety. If your machine was originally delivered with options fitted, replacing a safety component associated with a particular option not require any particular precautions other than those associated with the installation itself (static test).**

**Otherwise, it is essential to follow the manufacturer's recommendations below :**

- Installation by authorised HAULOTTE® personnel only.
- Update the manufacturer's identification plate.
- Have stability tests carried out by a certified agency/competent person.
- Ensure label compliance.

## 4 - HAULOTTE Services® contact details

## HAULOTTE Services® contact details

	<p>HAULOTTE FRANCE PARC DES LUMIERES 601 RUE NICEPHORE NIEPCE 69800 SAINT-PIERRE <b>TECHNICAL Department:</b> <b>+33 (0)820 200 089</b> <b>SPARE PARTS : +33 (0)820 205 344</b> FAX : +33 (0)4 72 88 01 43 E-mail : <a href="mailto:haulottefrance@haulotte.com">haulottefrance@haulotte.com</a> <a href="http://www.haulotte.fr">www.haulotte.fr</a></p>		<p>HAULOTTE ITALIA VIA LOMBARDIA 15 20098 SAN GIULIANO MILANESE (MI) <b>TEL: +39 02 98 97 01</b> FAX: +39 02 9897 01 25 E-mail : <a href="mailto:haulotteitalia@haulotte.com">haulotteitalia@haulotte.com</a> <a href="http://www.haulotte.it">www.haulotte.it</a></p>		<p>HAULOTTE INDIA Unit No. 1205, 12th floor, Bhumiraj Costarica, Plot No. 182, Sector 18, Palm Beach Road, Sanpada, Navi Mumbai- 400 705 Maharashtra, INDIA Tel. : +91 22 66739531 to 35 E-mail : <a href="mailto:sray@haulotte.com">sray@haulotte.com</a> <a href="http://www.haulotte.in">www.haulotte.in</a></p>
	<p>HAULOTTE HUBARBEITSBÜHNEN GmbH Ehrenkirchener Strasse 2 D-79427 ESCHBACH <b>TEL : +49 (0) 7634 50 67 - 0</b> FAX : +49 (0) 7634 50 67 - 119 E-mail : <a href="mailto:haulotte@de.haulotte.com">haulotte@de.haulotte.com</a> <a href="http://www.haulotte.de">www.haulotte.de</a></p>		<p>HAULOTTE VOSTOK 61A, RYABINOVAYA STREET Bldg. 3 121471 MOSCOW RUSSIA <b>TEL/FAX : +7 495 221 53 02 / 03</b> E-mail : <a href="mailto:info@haulottevostok.ru">info@haulottevostok.ru</a> <a href="http://www.haulotte-international.com">www.haulotte-international.com</a></p>		<p>HAULOTTE DO BRASIL AV. Tucunaré, 790 CEP: 06460-020 – TAMBORÉ BARUERI – SAO PAULO – BRASIL <b>TEL : +55 11 4196 4300</b> FAX : +55 11 4196 4316 E-mail : <a href="mailto:haulotte@haulotte.com.br">haulotte@haulotte.com.br</a> <a href="http://www.haulotte.com.br">www.haulotte.com.br</a></p>
	<p>HAULOTTE IBERICA C/ARGENTINA Nº 13 - P.I. LA GARENA 28806 ALCALA DE HENARES MADRID <b>TEL : +34 902 886 455</b> TEL SAT : +34 902 886 444 FAX : +34 911 341 844 E-mail : <a href="mailto:iberica@haulotte.com">iberica@haulotte.com</a> <a href="http://www.haulotte.es">www.haulotte.es</a></p>		<p>HAULOTTE POLSKA Sp. Z.o.o. UL. GRANICZNA 22 05-0-90 RASZYN - JANKI <b>TEL : +48 22 720 08 80</b> FAX : +48 22 720 35 06 E-mail : <a href="mailto:haulottepolska@haulotte.com">haulottepolska@haulotte.com</a> <a href="http://www.haulotte.pl">www.haulotte.pl</a></p>		<p>HAULOTTE MÉXICO, Sa de Cv Calle 9 Este, Lote 18, Cívac, Jiutepec, Morelos CP 62500 Cuernavaca México <b>TEL : +52 77 7321 7923</b> FAX : +52 77 7516 8234 E-mail : <a href="mailto:haulotte.mexico@haulotte.com">haulotte.mexico@haulotte.com</a> <a href="http://www.haulotte-international.com">www.haulotte-international.com</a></p>
	<p>HAULOTTE PORTUGAL ESTRADA NACIONAL NUM. 10 KM. 140 - LETRA K 2695 - 066 BOBADELA LRS <b>TEL : + 351 21 995 98 10</b> FAX : + 351 21 995 98 19 E-mail : <a href="mailto:haulotteportugal@haulotte.com">haulotteportugal@haulotte.com</a> <a href="http://www.haulotte.es">www.haulotte.es</a></p>		<p>HAULOTTE SINGAPORE Pte Ltd. No.26 CHANGI NORTH WAY, SINGAPORE 498812 <b>Parts and service Hotline:</b> <b>+65 6546 6150</b> FAX : +65 6536 3969 E-mail : <a href="mailto:haulotteasia@haulotte.com">haulotteasia@haulotte.com</a> <a href="http://www.haulotte.sg">www.haulotte.sg</a></p>		<p>HAULOTTE MIDDLE EAST FZE PO BOX 293881 Dubai Airport Free Zone DUBAI United Arab Emirates <b>TEL : +971 (0)4 299 77 35</b> FAX : +971 (0) 4 299 60 28 E-mail : <a href="mailto:haulottemiddle-east@haulotte.com">haulottemiddle-east@haulotte.com</a> <a href="http://www.haulotte-international.com">www.haulotte-international.com</a></p>
	<p>HAULOTTE SCANDINAVIA AB Taljegårdsgatan 12 431 53 Mölndal SWEDEN <b>TEL : +46 31 744 32 90</b> <b>FAX : +46 31 744 32 99</b> E-mail : <a href="mailto:info@se.haulotte.com">info@se.haulotte.com</a> <a href="mailto:spar@se.haulotte.com">spar@se.haulotte.com</a> <a href="http://www.haulotte.se">www.haulotte.se</a></p>		<p>HAULOTTE TRADING (SHANGHAI) Co. Ltd. #7 WORKSHOP No 191 HUA JIN ROAD MIN HANG DISTRICT SHANGHAI 201108 CHINA <b>TEL : +86 21 6442 6610</b> FAX : +86 21 6442 6619 E-mail : <a href="mailto:haulotteshanghai@haulotte.com">haulotteshanghai@haulotte.com</a> <a href="http://www.haulotte.cn">www.haulotte.cn</a></p>		<p>HAULOTTE ARGENTINA Ruta Panamericana Km. 34,300 (Ramal A Escobar) 1615 Gran Bourg (Provincia de Buenos Aires) Argentina <b>TEL: +54 33 27 445991</b> FAX. +54 33 27 452191 E-mail : <a href="mailto:haulotteargentina@haulotte.com">haulotteargentina@haulotte.com</a> <a href="http://www.haulotte-international.com">www.haulotte-international.com</a></p>
	<p>HAULOTTE UK Ltd STAFFORD PARK 6 TELFORD - SHROPSHIRE TF3 3AT <b>TEL : +44 (0)1952 292753</b> FAX : + 44 (0)1952 292758 E-mail : <a href="mailto:salesuk@haulotte.com">salesuk@haulotte.com</a> <a href="http://www.haulotte.co.uk">www.haulotte.co.uk</a></p>		<p>HAULOTTE GROUP / BILJAX 125 TAYLOR PARKWAY ARCHBOLD, OH 43502 – USA <b>TEL : +1 419 445 8915</b> FAX : +1 419 445 0367 Toll free : +1 800 537 0540 E-mail : <a href="mailto:sales@us.haulotte.com">sales@us.haulotte.com</a> <a href="http://www.haulotte-usa.com">www.haulotte-usa.com</a></p>		<p>HAULOTTE NORTH AMERICA 3409 Chandler Creek Rd. VIRGINIA BEACH, VA 23453 – USA <b>TEL : +1 757 689 2146</b> FAX : +1 757 689 2175 Toll free : +1 800 537 0540 E-mail : <a href="mailto:sales@us.haulotte.com">sales@us.haulotte.com</a> <a href="http://www.haulotte-usa.com">www.haulotte-usa.com</a></p>
	<p>HAULOTTE NETHERLANDS BV Koopvaardijweg 26 4906 CV OOSTERHOUT - Nederland <b>TEL : +31 (0) 162 670 707</b> FAX : +31 (0) 162 670 710 E-mail : <a href="mailto:info@haulotte.nl">info@haulotte.nl</a></p>		<p>HAULOTTE AUSTRALIA PTY Ltd 46 GREENS ROAD DANDENONG – VIC – 3175 <b>TEL : 1 300 207 683</b> FAX : +61 (0)3 9792 1011 E-mail : <a href="mailto:sales@haulotte.com.au">sales@haulotte.com.au</a></p>		<p>HAULOTTE CHILE El Arroyo 840 Lampa (9380000) Santiago (RM) <b>TEL : + 562 2 3727630</b> E-mail : <a href="mailto:haulotte-chile@haulotte.com">haulotte-chile@haulotte.com</a> <a href="http://www.haulotte-chile.com">www.haulotte-chile.com</a></p>

# A - Safety precautions

## 1 - Recommendations

### 1.1 - OPERATOR'S MANUAL

This operators manual is specific to the HAULOTTE® products listed on the cover page of this manual..



The operator manual does not replace the basic training required for all worksite equipment operators.







HAULOTTE® has compiled this manual to assist in safe and efficient operation of the products covered by the manual.

This manual must be kept on the machine (or in the cab in its storage case. The manual must be available to all operators and must be kept in good condition. Additional copies can be ordered from HAULOTTE Services®.

### 1.2 - SYMBOLS USED

Symbols are used to alert the operator to safety precautions or to highlight practical information.

#### Legend

Symbol	Meaning
	Danger : Risk of injury or death (work safety)
	Caution : Risk of material damage (work quality)
	Prohibition relating to work safety and quality
	Reminder : No identified risk, but a reminder of the need for common sense, good practice or pre-action prerequisites
	Cross-reference to another part of the manual (see section or sheet)
	Cross-reference to another manual (see manual)
	Cross-reference to repairs (contact HAULOTTE Services®)
N.B. :	Additional technical information

# A - Safety precautions

## 1.3 - LABEL COLORS

The potential dangers and any specific regulations are indicated around the product by labels and identification plates.



The labels must be kept in good condition. Additional labels can be ordered from HAULOTTE Services®.

Familiarize yourself with the labels and their respective color codes.

### Label color code

Labels	Color	Meaning
	Red	Potentially fatal danger
	Orange	Risk of serious injury
	Yellow	Risk of material damage and/or minor injury
	Other	Additional technical information
	Green	Maintenance operation or information

### Label color code-For the Eurasian Customs Union and the Ukraine only

Labels	Color	Meaning
	Red	Prohibitions - Danger
	Yellow	Warning : Risk of material damage and/or minor injury
	Blue	Precaution
	Blue	Information
	Other	Additional technical information

# A - Safety precautions

## 1.4 - SYMBOL AND HAZARD PICTORIALS DEFINITIONS

### 1.4.1 - Hazard Pictorial Descriptions

# A - Safety precautions

## Hazard Pictorial Descriptions

Marking	Description
1	Electrocution hazards
2	Maintain required clearance
3	Falling object hazard
4	No people under load
5	Fall hazard
6	No riders
7	Stabiliser extending onto foot
8	Keep clear of moving outriggers
9	Bodily injury hazard
10	Always wear the seat belt
11	Pressurized oil hazard
12	Use cardboard to search for leaks
13	Overturning hazard
14	Read the operator's manual
15	Keep away from moving parts
16	Crushing of the hand
17	Keep clear of moving parts
18	Load on the wheel
19	Being run over
20	Lower forks. Set the parking brake
21	Burn Hazard
22	Allow system to cool
23	Overturning hazard
24	Sway operation
25	Explosion hazard Burn Hazard
26	No smoking No open flame
27	Burn Hazard
28	Allow surfaces to cool
29	Being squashed by a falling load
30	Support boom when performing maintenance
31	Being squashed by a horizontal moving object
32	Keep away from moving parts
33	Keep load low
34	Operate from operator's station
35	Maximum effort on the stabilizers
36	Do not place your foot on the hood
37	Do not smoke close to the diesel tank
38	Do not use this area for welding mass
39	Do not use high pressure washer near the battery
40	Tire Pressure

# A - Safety precautions

## 2 - Work area safety

### 2.1 - OVERTURNING HAZARDS

Using the load chart, confirm that the load is within the rated capacity of the machine.



Do not exceed the rated load.



Do not raise the load unless the ground can support all forces imposed by the machine.



Do not lower a load without first retracting the boom.



Do not operate the machine if the load chart is missing or illegible.



Do not exceed the rated capacity for each configuration of boom.

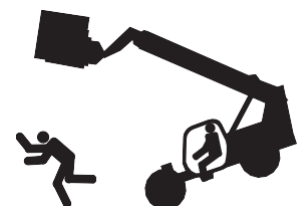

Do not raise the boom unless the machine is level. The machine level indicator should be at zero degrees.



Do not level the machine using the frame tilt control unless the boom angle indicator is at zero degrees or less.



Do not use the lateral boom levelling control to position an elevated load.



Do not raise a load and then drive to position it.



When driving, keep the boom at or below horizontal and keep the load close to the ground.



# A - Safety precautions

- Operate the machine at speeds that will keep the load stable and under control. Start and stop movements smoothly.



**Do not raise a load unless the load is properly positioned or secured on the forks or on a factory approved attachment.**

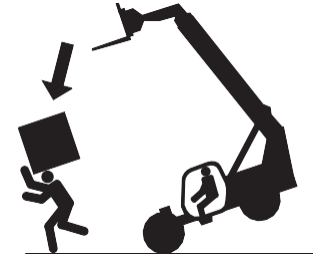

**Do not operate the machine in strong or gusty winds. Do not increase the surface area of the carriage or the load. Increasing the area exposed to the wind will decrease machine stability.**

- Use extreme care and slow speeds while driving the machine in the travel position across uneven terrain, debris, unstable or slippery surfaces and near holes and drop-offs.



**Do not alter or disable machine components that in any way affect safety and stability.**



**Do not replace items critical to machine stability with items of different weight or specification.**



**Do not replace factory-installed tires with tires of different specification or ply rating.**

# A - Safety precautions

## 2.2 - TRAVELLING ON SLOPES

When driving, keep the boom at or below horizontal and keep the load close to the ground.



- When travelling on inclines when the machine is loaded, always travel with the load up the incline. When travelling on inclines without a load, travel with the forks or attachment facing down the incline.



**On steep terrain, drive only up and down hill, and always keep the machine in gear. Do not turn across slope when machine is traveling up or down a slope.**

- Limit travel path and speed according to the condition of the ground surface, traction, slope, location of personnel and any other factors which may create a hazard.



**Never drive the machine unless the mast and equipment are in their proper travel position.**

- Whether a machine will tip over during dynamic machine operation involves many factors that need to be considered. Among these are pavement/ground conditions, stability and slope, as well as machine equipment, operator skill, load position, tire inflation, machine speed, etc.
- Additionally, tip over of a machine is dependent in large part upon operator inputs such as the speed and smoothness of the operation as well as the position of the attachment and its load.
- Construction sites and roads can and do frequently change terrain from location to location, can be firm and loose, and also change due to the construction activities and weather conditions.
- Operators should be properly trained and use their best judgment and experience to take the necessary precautions to prevent tip over. Operators must assess the jobsite variables and avoid exceeding the machine's (or operator's) capabilities for terrain and conditions.

A

B

C

D

E

F

G

H

I

# A - Safety precautions

## 2.3 - FALL HAZARDS

- Always wear a seat belt when operating the machine.

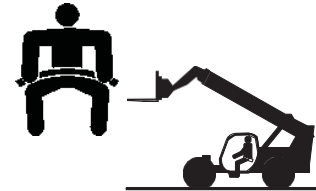

Always remain completely inside the cab when operating the machine.



- When getting in and out of the cab, face the machine, use the steps and handrails provided and always maintain three-point contact.



**Do not use the steering wheel or any other controls as handrails.**



**Do not allow riders on the machine or forks.**



**Do not transport or lift personnel with this machine.**

# A - Safety precautions

## 2.4 - COLLISION HAZARDS

-  Keep people, equipment and material out of the work area. Do not operate the machine while people are under or near an elevated boom, whether it is loaded or unloaded.

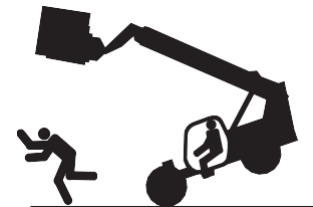

-  Do not put the transmission into drive mode unless the parking brake is set..

-  Do not drive the machine if visibility is obstructed.

-  Do not raise the boom unless the parking brake is set.

-  Do not operate the machine with a faulty reversing alarm.

- Operators must comply with employer, job site and statutory rules regarding the use of personal protective equipment.

## 2.5 - FALLING OBJECT HAZARDS

-  Operate the machine at speeds that will keep the load stable and under control. Start and stop movements smoothly.

-  Keep people, equipment and material out of the work area. Do not operate the machine while people are under or near an elevated boom, whether it is loaded or unloaded.



# A - Safety precautions

## 2.6 - BODILY INJURY HAZARD

Always adjust the seat and fasten the seat belt before starting the engine.

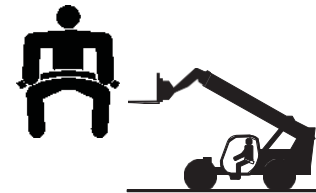

**Do not operate the Telehandler if it has a hydraulic or air leak. Escaping fluid under pressure can penetrate skin, causing serious injury. Relieve pressure before disconnecting hydraulic lines. Keep away from leaks and pin holes.**



**Use a piece of cardboard or paper to search for leaks. Do not use your hand.**



- Fluid injected into skin must be surgically removed within a few hours by a doctor familiar with this type of injury or gangrene will result.
- Always operate the machine in a well-ventilated area to avoid carbon monoxide poisoning.
- Unintended contact with components under any cover may cause serious injury. Only trained personnel should remove covers to gain access to potentially hazardous compartments such as the engine compartment. Access by the operator is only advised when performing a pre-operation inspection. All compartments must remain closed and secured during normal Telehandler operation.

## 2.7 - DAMAGED MACHINE HAZARDS



**Do not use a damaged or malfunctioning machine.**

- Conduct a thorough pre-operation inspection of the machine and test all functions before each work shift. Immediately tag and remove from service a damaged or malfunctioning machine.
- Be sure all maintenance has been performed as specified in this manual.
- Be sure all decals are in place and legible.
- Be sure the operator's and safety manuals are complete, legible and in the storage container located in the cab.







**Do not attempt to start the machine by towing or pushing it.**



**Do not attempt to use the forks or attachments for prying wedged or frozen loads free.**

# A - Safety precautions

## 2.8 - COMPONENT DAMAGE HAZARDS

-  Do not use any battery or charger greater than 12 V to jump-start the engine.
-  Do not use the machine as a ground for welding.
-  Do not attempt to steer the front tires on dry pavement when the axle differential lock is activated.
-  Do not attempt to lock the axle differential when the machine is moving.
-  Do not drive the machine unless the stabilizers are fully retracted.

## 2.9 - CRUSH HAZARDS

- Keep clear of moving stabilizers.

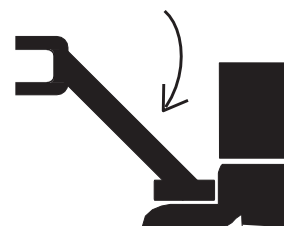

- Keep clear of moving parts during machine operation.
- Set the parking brake, put the transmission in neutral and lower the carriage or the removable attachment to the ground before leaving the machine.
- Keep clear of elevated components.
- Support components before performing service.

## 2.10 - BURN HAZARDS

Allow hot surfaces to cool before touching or servicing on or near them.

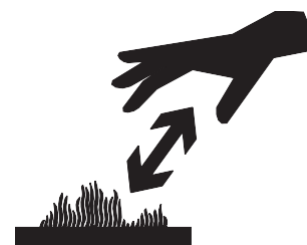

# A - Safety precautions

## 2.11 - EXPLOSION AND FIRE HAZARDS

 Do not start the engine if you smell or detect liquid petroleum gas (LPG), gasoline, diesel fuel or other explosive substances.

 Do not refuel the machine with the engine running.

Refuel the machine and charge the battery only in an open, well-ventilated area away from sparks, flames and lighted tobacco.

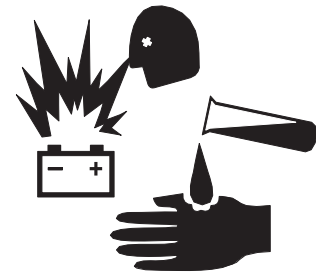

 Do not operate the machine in hazardous locations or locations where potentially flammable or explosive gases or particles may be present.

 Do not spray ether into engines equipped with glow plugs or air intake grid heaters.

Areas with explosive atmospheres :

 Before entering an explosive atmosphere (e.g. silo, etc.) and to avoid any risk of explosion, particulate filter regeneration must be manually disabled (  Section C 3.5.9 - Left-hand control panel).

# A - Safety precautions

## 2.12 - ELECTROCUTION HAZARDS

Maintain an appropriate clearance from electrical power lines. See the chart below for required clearance.

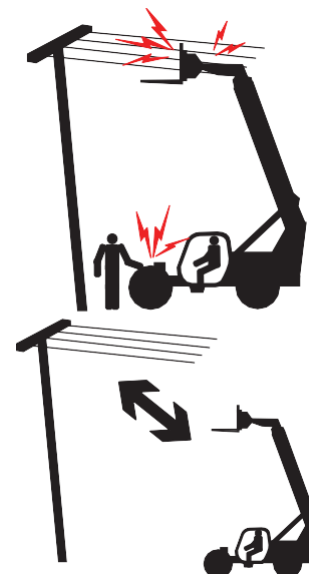

Minimum safety distance

Line voltage	Required clearance	
0 to 50 KV	10 ft	3.05 m
50 to 200 KV	15 ft	4.6 m
200 to 350 KV	20 ft	6.10 m
350 to 500 KV	25 ft	7.62 m
500 to 750 KV	35 ft	10.67 m
750 to 1000 KV	45 ft	13.72 m



**Do not use the machine as a ground for welding.**

Always contact the electric power line owner when working near power lines. The electric power shall be disconnected or the power lines moved or insulated before machine operations begin.

# A - Safety precautions

## 2.13 - BATTERY SAFETY

### 2.13.1 - Burn hazards



**Batteries contain acid. Always wear protective clothing and eye wear when working with batteries.**

Avoid spilling or contacting battery acid. Neutralize battery acid spills with baking soda and water.

### 2.13.2 - Explosion hazard

Batteries emit explosive gas. Keep sparks, flames and lighted tobacco away from batteries.

### 2.13.3 - Electrocuting hazard

Avoid contact with electrical terminals.

# B - Intervenor's responsibility

## 1 - Owner's (or hirer's) responsibility

The owner (or hirer) has the obligation to inform operators of the instructions contained in the Operator Manual.

The owner (or hirer) has the obligation to renew all manuals or labels that are either missing or in bad condition. Additional copies can be ordered from HAULOTTE Services®.

The owner (or hirer) is responsible for applying the local regulations regarding operation of the machine.

## 2 - Employer's responsibility

The employer has the obligation to issue a driving permit to the operator.

*N.B.:-In accordance with the regulation in the country where the machine is operating, the user must be authorized to drive by the doctor of Labour Ministry.*



**Forbid anyone from operating the machine who is :**

- Under the influence of drugs, alcohol, etc..
- subject to fits, loss of motor skills, dizziness, etc..

## 3 - Trainer's responsibility

The trainer must be qualified to provide training to operators in accordance with applicable local regulations. The training must be given in an obstacle-free area until the trainee is considered competent as defined by the training program undertaken.

## 4 - Operator's responsibility

The operator must read and understand the contents of this manual and the labels affixed on the machine.

The operator must inform the owner (or hirer) if the manual or any labels are missing or in poor condition, and of any malfunction of the machine.

The operator may only operate the machine for the purpose intended by the manufacturer.



**Only authorized and qualified operators may operate HAULOTTE® machines.**

All operators must become familiar with and fully understand the emergency controls and how to operate the machine in an emergency as a component of their formal operator training.

The operator has the obligation stop using the machine in the event of malfunction or safety problems on the machine or in the work area and report the problem to his/her supervisor.

# B - Intervenor's responsibility



## 5 - Inspection and maintenance

The inspection and maintenance table below, identifies the role and the responsibilities of each party in periodical machine maintenance..



If the machine is operated in a hostile environment or intensively, increase the frequency of maintenance.

### Inspections and maintenance

Type of intervention	Frequency	Person-in-charge	Intervenor	Reference document
Pre-delivery inspection	Before each delivery of sold, hired or resold equipment	Owner (or hirer)	Qualified HAULOTTE Services® technician	Operator's manual
Pre-operation inspection	Before operation or when the operator changes	Operator	Operator	Operator's manual  Section C - Pre-operation and controls
Periodical preventive maintenance	At the specified intervals (250 hours or 1 year)	Owner (or hirer)	On-site technician or qualified HAULOTTE Services® technician	Operator's manual  Section H - Lubrication and maintenance
Periodical visit	2 times a year or at the latest 6 months after the last periodic visit, and according to the local regulations	Owner (or hirer)	Organization or technician approved by the employer or by the intermediary of HAULOTTE Services® in accordance with the HAULOTTE Services® contract	Operator's manual  Section H - Lubrication and maintenance

# C - Pre-operation and controls

## 1 - Checks before use

Each day and before the beginning of a new work period and on each change of operator, the machine must be subjected to a visual inspection and a complete functional test.

Any repairs required must be performed before the machine is used, its correct operation depends on it.

### 1.1 - GENERAL MECHANICAL FUNCTIONS

For all the following checks, ensure that the machine is switched off.

Check the following points :

- The presence of the identification plate, labels and operator manual :
  - Their state of cleanliness and visibility.
- Visual state of the machine :
  - Absence of leaks (battery acid, hydraulic oil, etc.). Absence of foreign objects on all surfaces. Call the staff in charge of the maintenance if necessary.
  - No missing or loose parts (bolts, nuts, connectors, cables, etc.).
  - Absence of cracks, broken parts, damaged paint. No deformations or other anomalies on the structure's parts.

#### Example

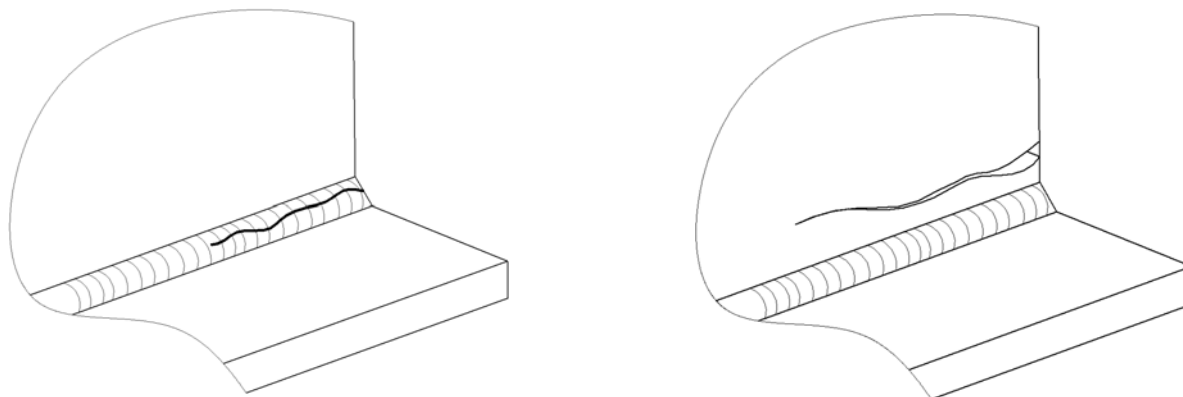

- State of the structure's parts : Chassis, boom, cab, tool holder, attachments :
  - No cracks, damaged paint.
  - No distortion in metal components or visible damage.
  - No foreign objects at the ends of the booms, between arms and link parts.
  - Presence of guardrails.
  - Presence and check the original position of the driving station system.
- Cylinders' state :
  - No leaks.
  - No rust and abrasions on the cylinder rod.
  - Absence of foreign objects on all surfaces.

# C - Pre-operation and controls

- Steering system's state : axles, wheels and tyres :
  - No cracks, distortions, damaged paint or other faults
  - No missing or loose bolts.
  - Condition of the tyres (cuts, excessive wear, etc.).
- State of the rotation systems (Cage option, pulleys, ...)
  - No excessive clearance.
  - No missing or loose bolts.
  - Absence of foreign objects on all surfaces.
  - Greasing and lubrication according to the maintenance plan.
- State of the control boxes :
  - No damage.
  - Back to neutral for all joysticks, selectors, etc..
  - Presence and readability of the control box labels.
- Movement, safety limit switches :
  - No damage.
  - No missing or loose bolts.
  - Absence of foreign objects on all surfaces.
- The state and connection of the electric wires and cables :
  - No damage, wear marks or other faults.
  - No contact between connectors.
- State of the tanks :
  - No leaks.
  - No missing or loose parts (bolts, nuts, connectors, cables, etc.).
  - Hydraulic oil level : Top up the oil level, if necessary (Machine in transport position).
  - Sufficient fuel level.
  - Sufficient engine oil.
  - Coolant level.
- State of the hydraulic pump :
  - No leaks.
  - No missing or loose parts (bolts, nuts, connectors, cables, etc.).
- Hydraulic oil filter.

# C - Pre-operation and controls

## 2 - Pre-operation checks and inspection

*N.B.-: Perform all required maintenance work before operating the unit.*





Use extreme caution when checking parts that are difficult to reach. Use an approved ladder. "Failure" to comply with these instructions could result in death or serious injury.



Increase in periodical inspections : Depending on the condition of certain critical components after 5000 hours, the maintenance staff may have to reduce the interval between periodical inspections and maintenance. If the decision is made not to replace a part, the part concerned must be recorded in the inspection schedule.

Inspect the following items :

- The condition of structural parts: chassis, boom, cab, shield, attachments.
  - Absence of cracks, broken parts, damaged paint.
  - No distortion in metal components or visible damage.
  - Absence of foreign objects at the ends of boom/attachments.
- Cylinders :
  - No leaks : Please refer to paragraph 7.2.2 (  Section H - Lubrication and maintenance).
  - No rust and abrasions on the cylinder rod.
  - Absence of foreign objects on all surfaces.
- Steering system : Wheels, Axles, Brake and Tyres :
  - No cracks, distortions, damaged paint or other faults.
  - No missing or loose bolts.
  - Condition of the tyres (cuts, excessive wear, etc.)
- Condition of the pulley system :
  - No missing or loose bolts.
  - Absence of foreign objects on all surfaces.
  - Grease the extension system if necessary.
- A walk-around inspection must be performed at the beginning of each work shift or at each change of operator.
- Ensure that all safety labels are legible and in place. Clean or replace if necessary. (  Section C 2 - Labels).
- Before removing the filler plugs, wipe all dirt or grease away from the ports. Dirt entering these ports can severely reduce component life.
- When adding fluids, determine the correct type and frequency (  Section H - Lubrication and maintenance).

# C - Pre-operation and controls

### Major Component Location Diagram

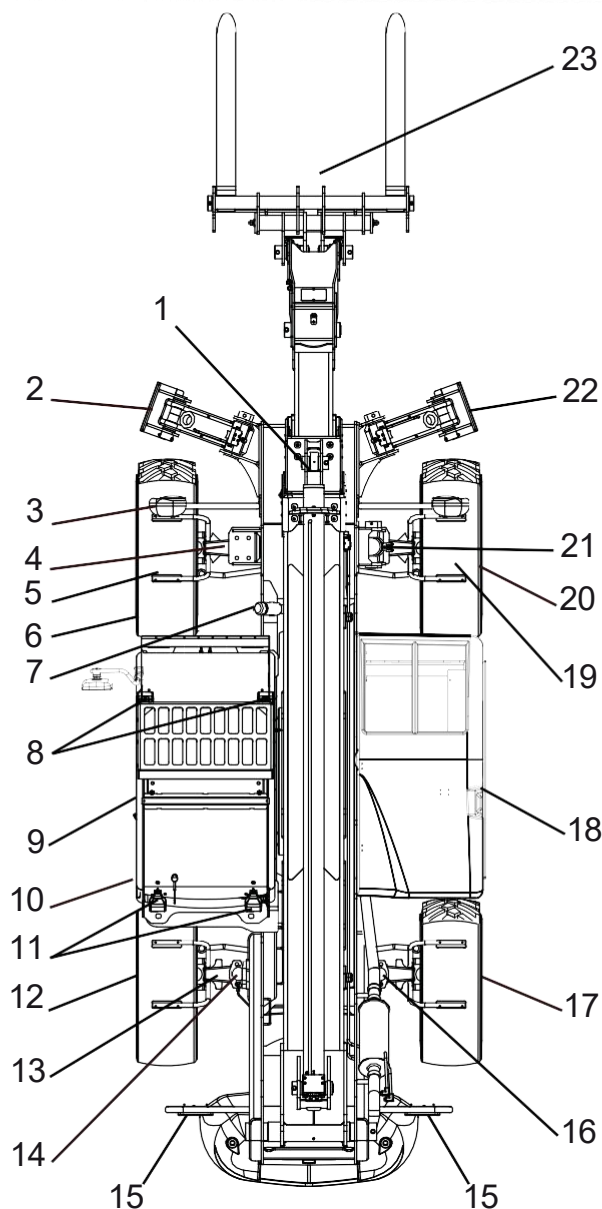

Begin the walk-around inspection at item 1, as indicated below.

Continue to the right (anticlockwise, when viewed from above) checking each part in sequence.

**N.B.:-** For each component, ensure that there are no loose or missing parts, that the components are securely fastened and that there are no visible leaks or excessive wear in addition to any other criteria mentioned. Inspect all structural elements including the attachment for cracks, excessive corrosion and other damage.

# C - Pre-operation and controls

1. Jib cylinders, lifting, telescoping, compensation output and input, cases :
  - Pins secure, hydraulic hoses in good condition, no leaks.
  - Check the tension of the extension and retraction cables and the adjustment shims.
  - Check the state of the extension booms wear pads.
2. Left-hand stabiliser and stabilizer foot plates : Pins secure, hydraulic hoses in good condition, no leaks.
3. Headlights : Clean, in good condition and working properly.
4. Front axle : Steering cylinders in good condition, no leaks, pivot pins secure, hydraulic hoses in good condition, no leaks.
5. Mirrors (optional) : Clean, in good condition and working properly.
6. Wheel/Tyre assembly : No loose or missing wheel nuts, inflated correctly. Check the state of the tyres and their level of wear. →
7. Hydraulic oil tank : Recommended fluid level on the level gauge (the oil must be cold) ; filler/breather cap securely in place and in working order. Check for hydraulic leaks around the reservoir.
8. Front work lights (optional) : Clean, in good condition and working properly.
9. Cab and electrical circuit :
  - The cab is an approved protective cab in accordance with FOPS and ROPS standards: Check the FOPS/ROPS label in the cab.
  - Check alarms: eg. engage the reverse drive and sound the horn.
  - General appearance, no visible damage, capacity charts and Operator & Safety manual located in the manual holder.
  - Window glass in good condition and clean.
  - Gauges, switches, joystick, parking brake pedals and horn all operational.
  - Check the seat belt for damage, replace it if it is frayed or the webbing is cut, the buckles are damaged or the mounting hardware is loose or damaged.
  - Open the inspection flap under the cab and check the battery cables : Correctly attached, no visible damage or corrosion.
  - Check for the presence of the load and capacity charts.
10. Fuel tank : Check the fuel level, top up as required, the filler cap is securely fastened.
11. Rear work lights (optional) : Clean, in good condition and working properly.
12. Wheel/Tyre assembly : No loose or missing wheel nuts, inflated correctly. Check the state of the tyres and their level of wear.
13. Rear axle : Steering cylinders in good condition, no leaks, pivot pins secure, hydraulic hoses in good condition, no leaks.
14. Left axle locking cylinder : Cylinders in good condition, no leaks and securely fastened.
15. Rear lights : Clean, in good condition and working properly.
16. Right axle locking cylinder : Cylinders in good condition, no leaks and securely fastened.
17. Wheel/Tyre assembly : No loose or missing wheel nuts, inflated correctly. Check the state of the tyres and their level of wear.

# C - Pre-operation and controls

18. Engine compartment :
  - Engine crankcase and radiator : Check the levels and top up as required. Check that the radiator is clean.
  - Drive belt : check their condition, adjust and/or replace as required.
  - Air filter blockage indicator : Check if it is clogged. Replace the element as required.
  - Engine canopy properly secured and locked.
  - Diesel particulate filter : Check the connection of all the probes. Ensure that the particulate filter has not been damaged (impact, deterioration, etc.). <sup>(1)</sup>
  - Engine calculator : Check the connection of the electrical connectors. Ensure that the engine calculator has not been damaged (impact, deterioration, etc.). <sup>(2)</sup>
19. Mirrors : Clean, in good condition and working properly.
20. Wheel/Tyre assembly : No loose or missing wheel nuts, inflated correctly. Check the state of the tyres and their level of wear.
21. Tilt correction cylinder : Pins secure, hydraulic hoses in good condition, no leaks.
22. Right-hand stabiliser and stabilizer foot plate : Pins secure, hydraulic hoses in good condition, no leaks.
23. Attachment : Correctly installed (  Section E - Attachments).

**Check the operation of :**

- **All the Telehandler boom and chassis side tilt movement.**
- **All the functions related to the travel of the Telehandler.**
- **The Telehandler braking system.**

(1.) For machines fitted with engine PERKINS 854E-34TA only  
(2.) For machines fitted with engine PERKINS 854E-34TA only

# C - Pre-operation and controls

## 3 - Safety stickers

### 3.1 - IDENTIFICATION

Localization: isometric view - HTL 9045 - HTL 9055 - Standards ANSI and CSA

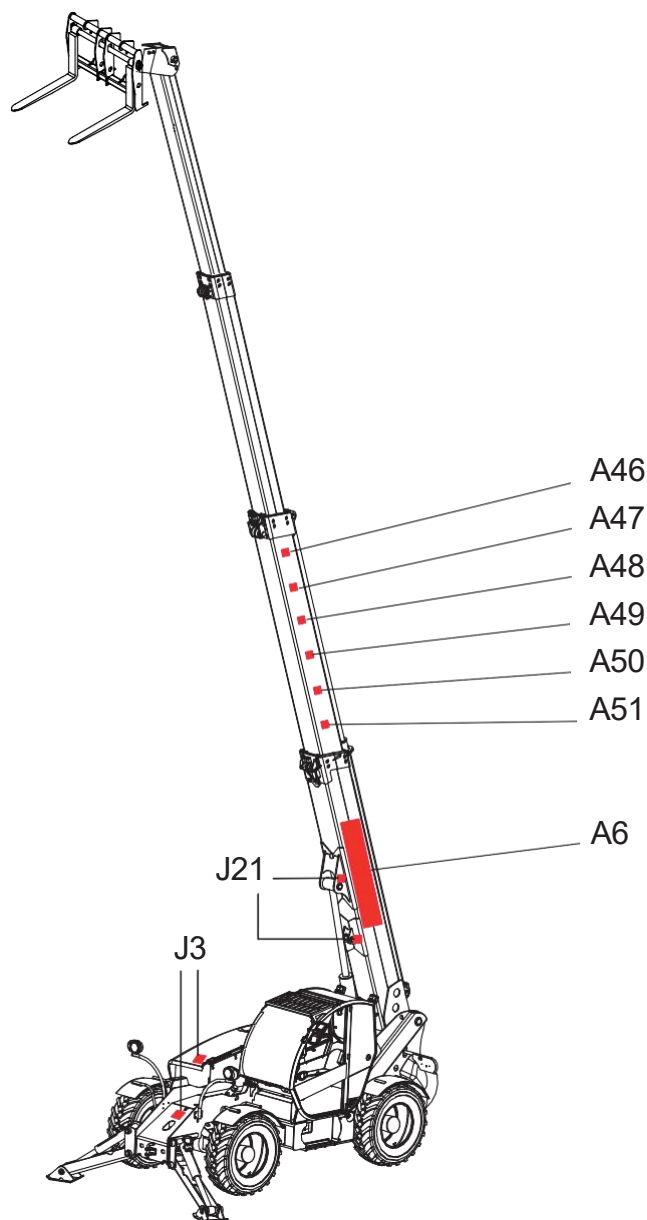

A

B

> C

D

E

F

G

H

I

# C - Pre-operation and controls

Localization: front view - HTL 9045 - HTL 9055 - Standards ANSI and CSA

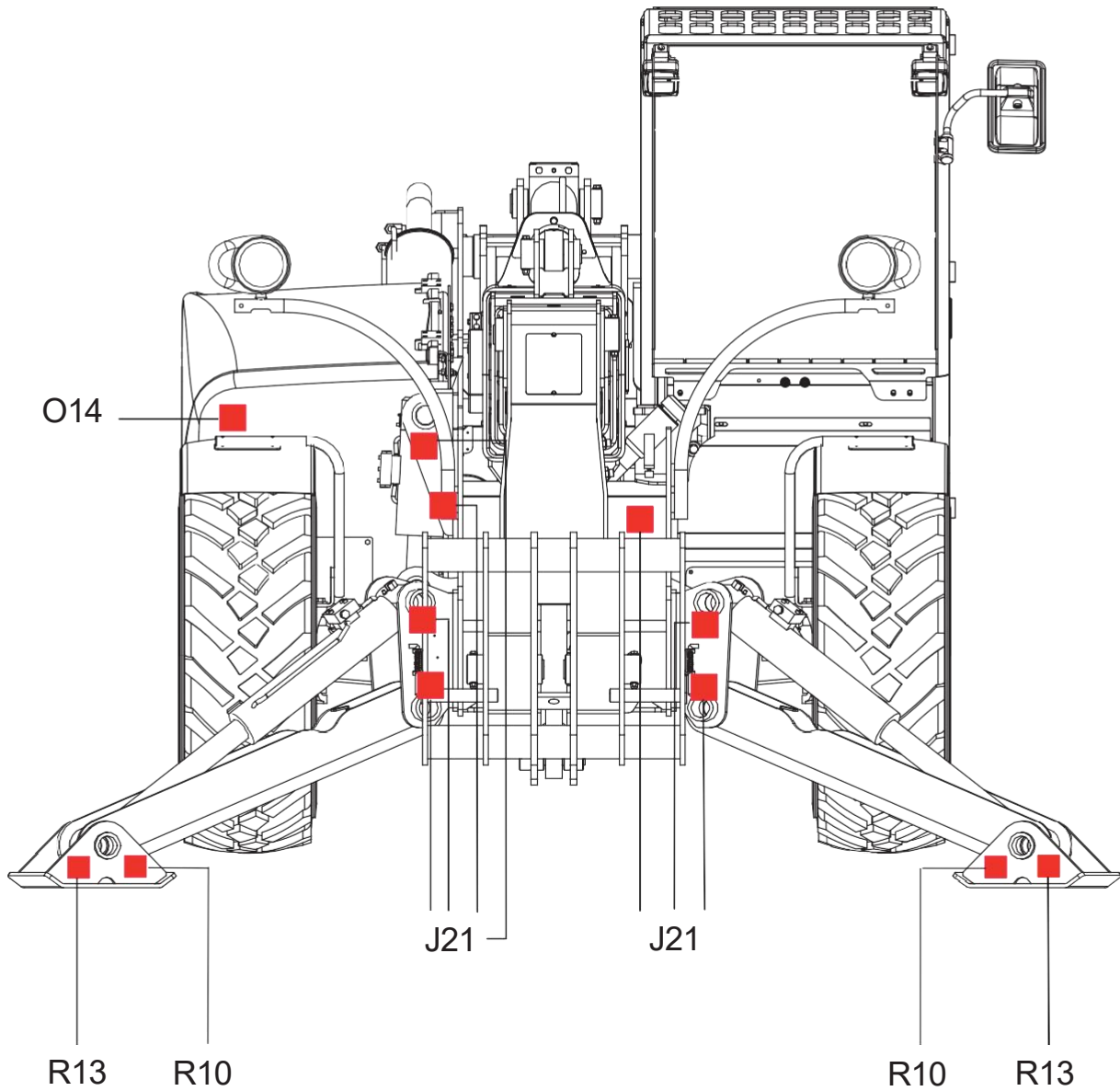

# C - Pre-operation and controls

Localization: left view - HTL 9045 - HTL 9055 - Standards ANSI and CSA

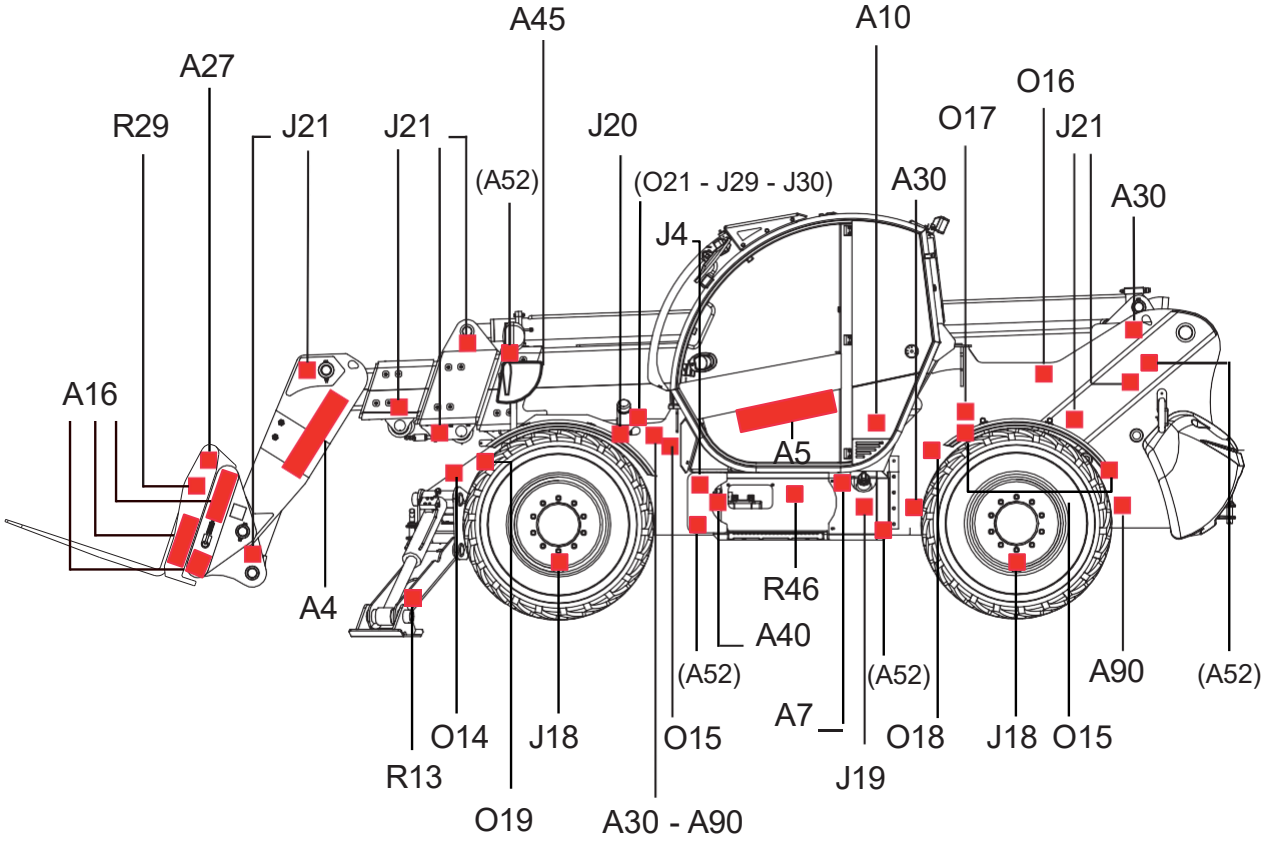

Localization: right view - HTL 9045 - HTL 9055 - Standards ANSI and CSA

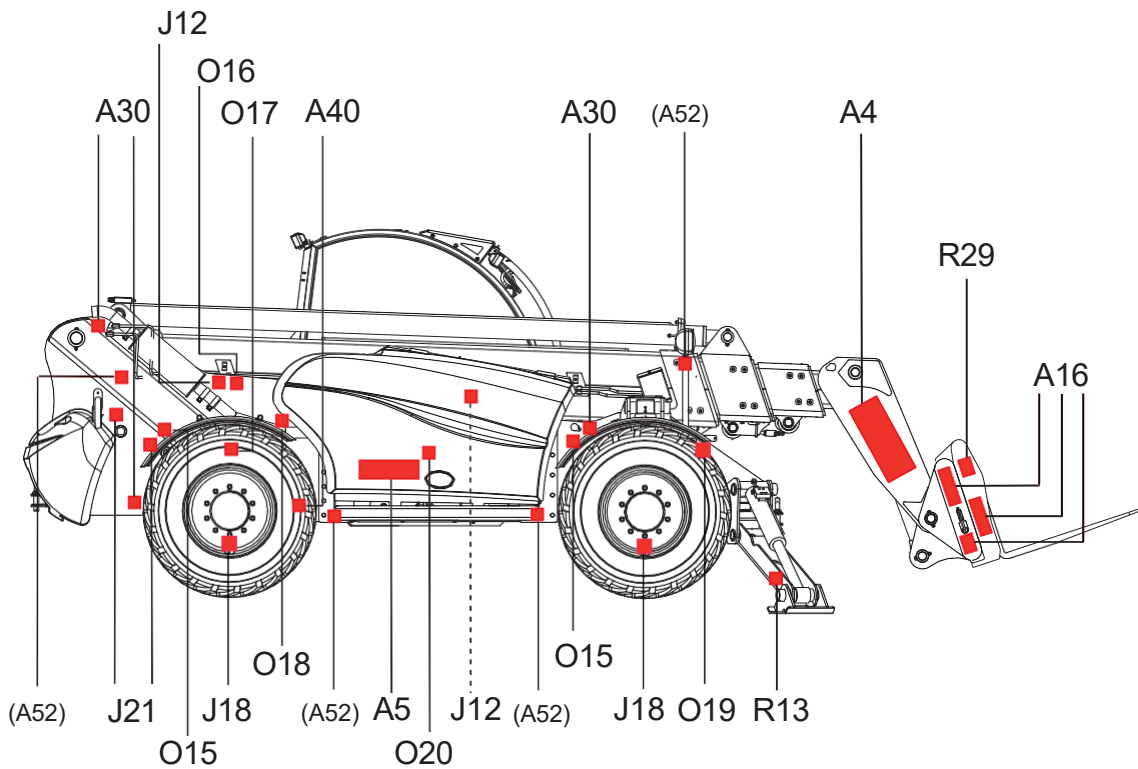

# C - Pre-operation and controls

Localization: cab view - HTL 9045 - HTL 9055 - Standards ANSI and CSA

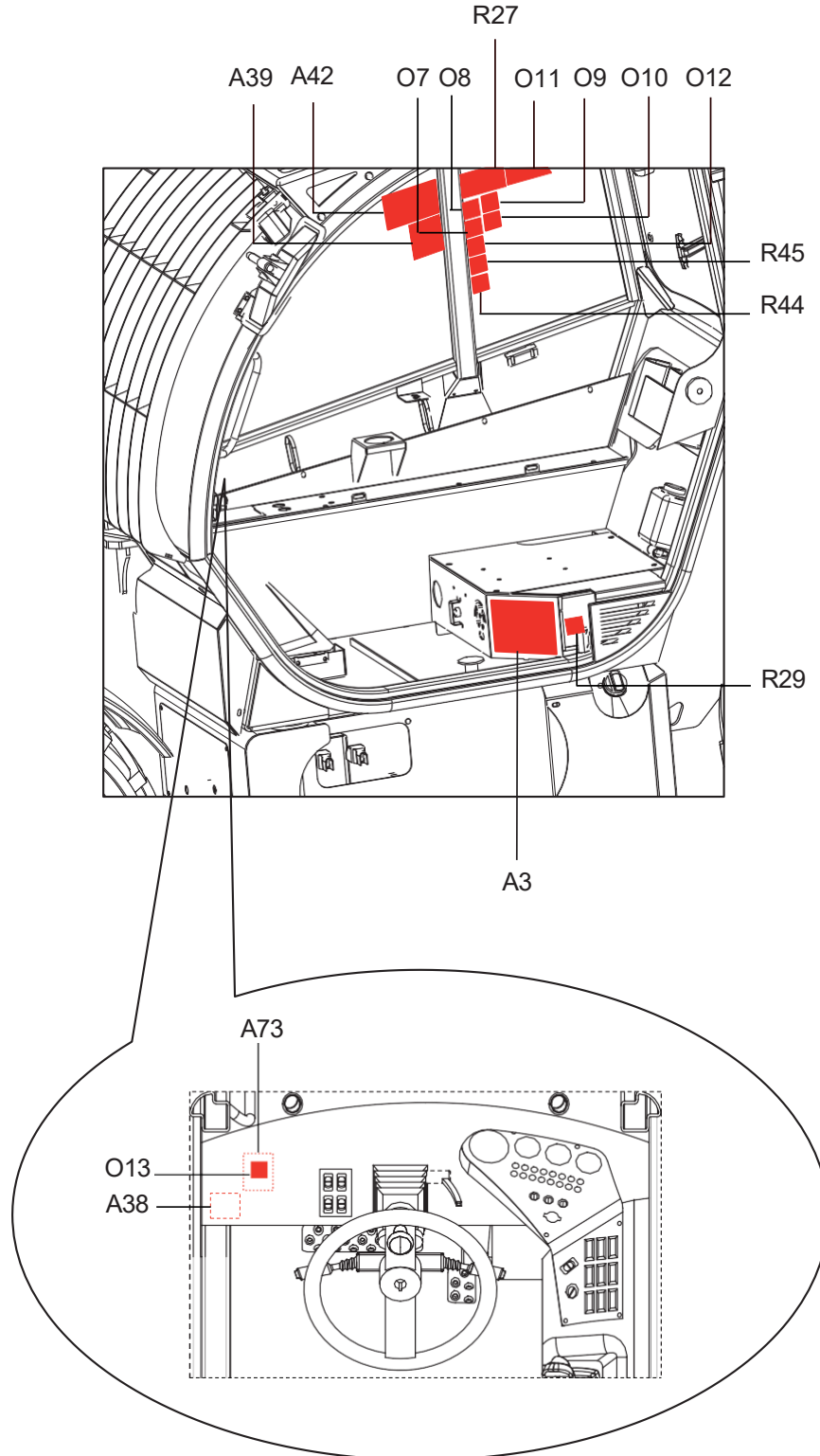

# C - Pre-operation and controls

Localization: view from above - HTL 9045 - HTL 9055 - Standards ANSI and CSA

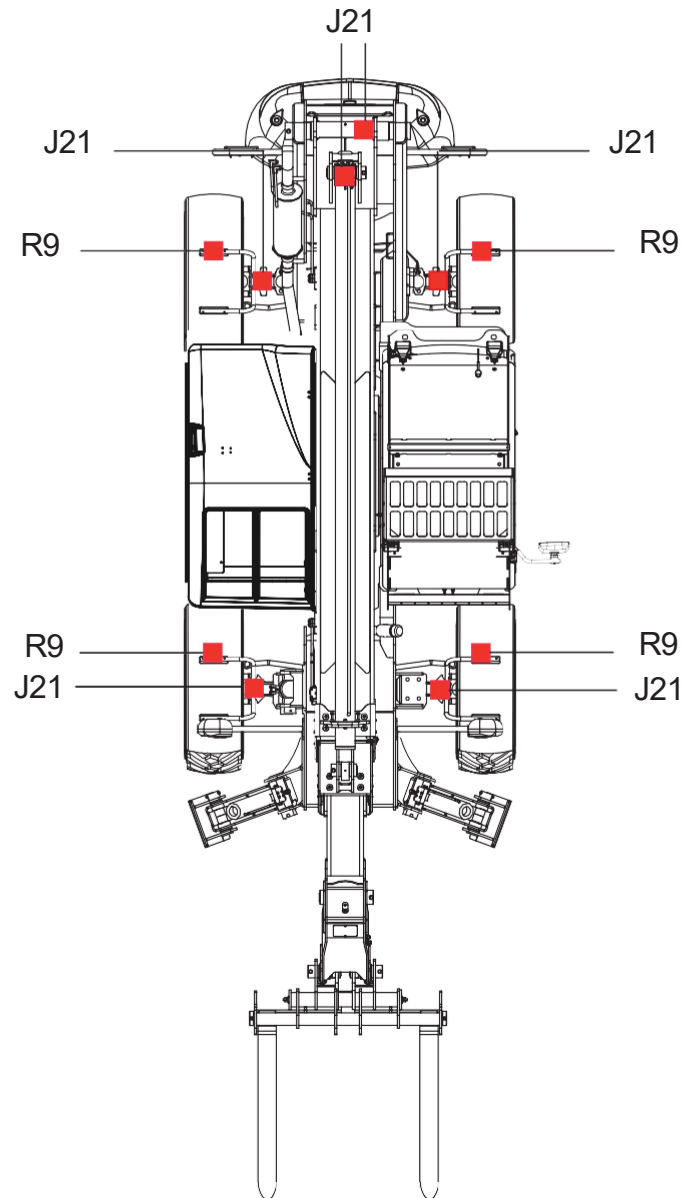

A

B

C

D

E

F

G

H

I

# C - Pre-operation and controls

Localization: rear view - HTL 9045 - HTL 9055 - Standards ANSI and CSA

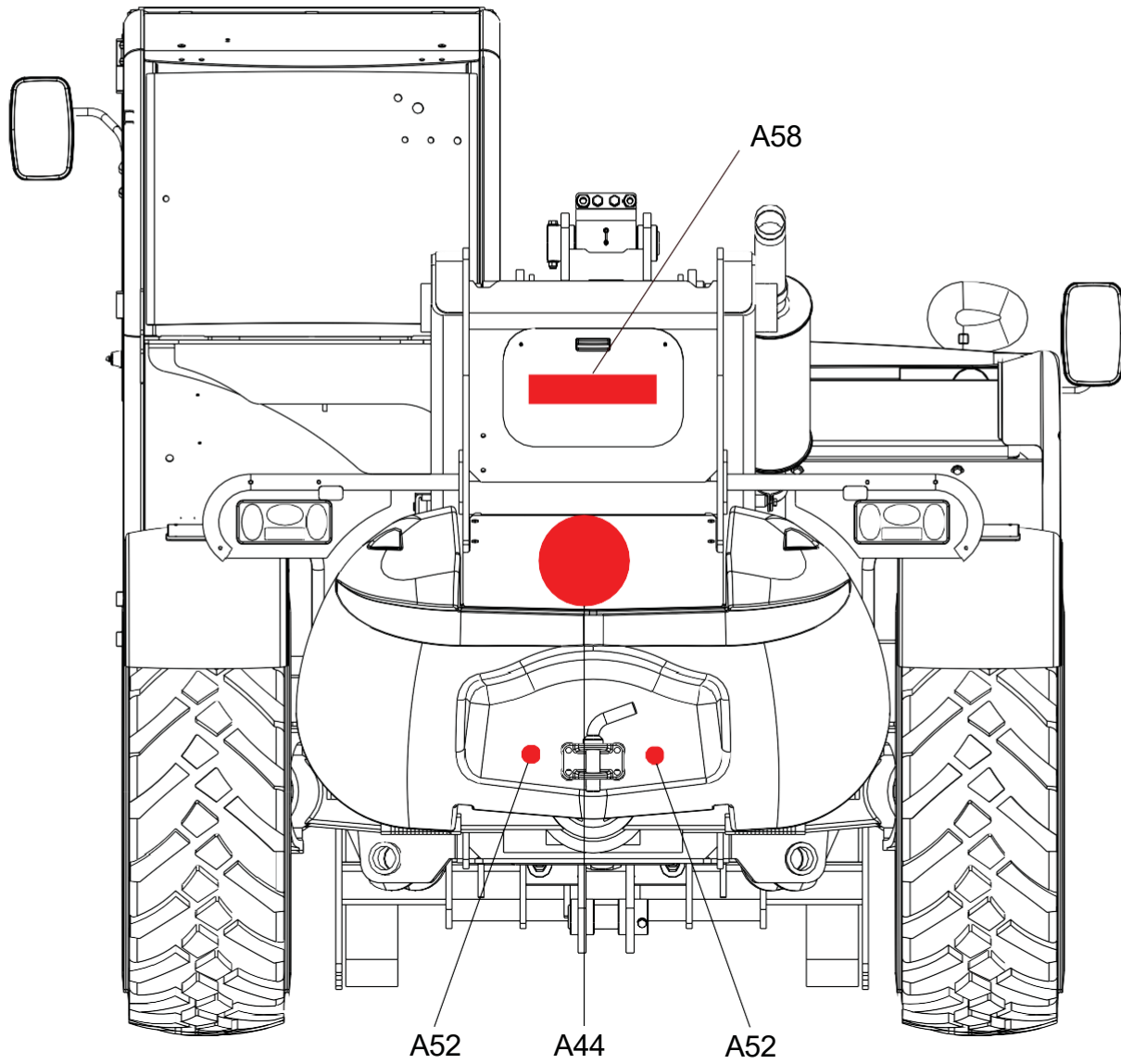

# C - Pre-operation and controls

## Common labels - Standards ANSI and CSA

Color	Marking	Description	Quantity	
Other	A3	Identification plate	1	307P224450
Other	A4	Machine name logo	2	For HTL 9045 : 4000104810 For HTL 9055 : 4000129580
Other	A5	Label HAULOTTE®	1	307P224740
Other	A6	Label HAULOTTE®	1	307P217770
Other	A7	Read the operation manual	1	307P225770
Other	A10	Noise emission level	1	4000053980
Other	A16	Yellow and black adhesive tape	1	2421808660
Other	A30	Slings attached	4	307P225530
Other	A38	Terminal fuses	1	4000023340
Other	A39	Joystick	1	307P226450
Other	A40	Battery / Battery isolation switch	1	307P225540
Other	A45	Angle sensor	1	307P220900
Other	A46	Telescoping key A	1	307P222610
Other	A47	Telescoping key B	1	307P222620
Other	A48	Telescoping key C	1	307P222630
Other	A49	Telescoping key D	1	307P222640
Other	A50	Telescoping key E	1	307P222650
Other	A51	Telescoping key F	1	307P222660
Other	A90	Anchor points on the machine	4	307P226100
Yellow	J3	Do not place your foot on the cover	2	307P225480
Yellow	J4	Ground for welding	1	307P225490
Yellow	J12	Danger of Heat burns	1	307P225410
Yellow	J18	Tyre pressure 5,1 bar (74 PSI)	4	307P225570
Yellow	J19	Fuel tank	1	307P225580
Yellow	J20	Hydraulic oil	1	307P225590
Yellow	J21	Lubrication	24	307P225600
Red	R9	Maximum effort on wheel	4	307P225500
Red	R10	Maximum effort on the stabilizers	2	307P225620
Red	R13	Risk of crushed feet	2	307P225400
Red	R27	Danger of electrocution	1	307P225340
Red	R29	Do not mount on the forks during elevation	2	307P225310
Red	R44	Risk of body crushing	1	307P225320
Red	R45	Boom in low position brake engaged	1	307P225370
Red	R46	Chemical burns hazards	1	307P225460
Orange	O7	Read the operation manual	1	307P225270
Orange	O8	Stay in the machine	1	307P225280
Orange	O9	Risk of overturning	1	307P225290
Orange	O10	Load falling hazards	1	307P225300
Orange	O11	Risk of overturning	1	307P225330
Orange	O12	Risk of overturning	1	307P225350
Orange	O13	Obligatory load chart	1	307P225360
Orange	O14	Risk of body crushing	2	307P225380
Orange	O15	Risk of body crushing	5	307P225390
Orange	O16	Risk of oil injection	2	307P225420
Orange	O17	Risk of crushed hands	1	307P225430
Orange	O18	Risk of body crushing	2	307P225440
Orange	O19	Load falling hazards	1	307P225450
Orange	O20	Mechanical risk	1	307P225470

# C - Pre-operation and controls

Load capacity chart - Standards ANSI and CSA

Color	Marking	Description	Quantity	HTL 9045	HTL 9055
Other	A42	Load capacity chart	1	307P225730	307P224520
Other	A73	Load capacity chart - Book	1	197P347200	194P347250
Other		Load capacity chart - Cover book	1	4000498110	4000498100
Other		Load capacity chart Forks on wheels	1	4000501900	4000501910
Other		Forks on stabilisers Load capacity chart			
Other		Bucket for lifted stabilizers	1	4000501830	4000501840
Other		Bucket for lowered stabilizers Load capacity chart			
Other		Double offset carriage on wheels	1	4000501980	4000501990
Other		Double offset carriage on stabilisers Load capacity chart			
Other		Jib crane 1 m 3 T on wheels	1	4000507410	4000507420
Other		Jib crane 1 m 3 T on stabilisers Load capacity chart			
Other		Jib crane fitted swivel hook 2 m, 2 T lifted stabilisers	1	4000507500	4000507510
Other		Jib crane fitted swivel hook 2 m, 2 T lowered stabilisers Load capacity chart			
Other		Fly jib 2,5 m, 1,2 T lifted stabilisers	1	4000507620	4000507630
Other		Fly jib 2,5 m, 1,2 T lifted stabilisers Load capacity chart			
Other		Fly jib 4 m, 0,6 T lifted stabilisers	1	4000507700	4000507710
Other		Fly jib 4 m, 0,6 T lowered stabilisers Load capacity chart			
Other		Winch 2,4 T lifted stabilisers	1	4000507780	4000507790
Other		Winch 2,4 T lowered stabilisers Load capacity chart			
Other		Winch 1,2 T lifted stabilisers	1	4000507880	4000507890
Other		Winch 1,2 T lowered stabilisers Load capacity chart			
Other		Fork positioner for lifted stabilizers	1	4000532230	4000532240
Other		Fork positioner for lowered stabilizers Load capacity chart			
Other		Fork grapple for lifted stabilizers	1	4000480560	4000480540
Other		Fork grapple for lowered stabilizers Load capacity chart			
Other		Bale spear 2 point for lifted stabilizers	1	4000555240	4000555290
Other		Bale spear 2 point for lowered stabilizers Load capacity chart			
Other		Bale spear 6 point for lifted stabilizers	1	4000555490	4000555520
Other		Bale spear 6 point for lowered stabilizers Load capacity chart			
Other		Platform	1	4000560010	

# C - Pre-operation and controls

Localization: isometric view - HTL 8045 - HTL 8055 - Standards ANSI and CSA

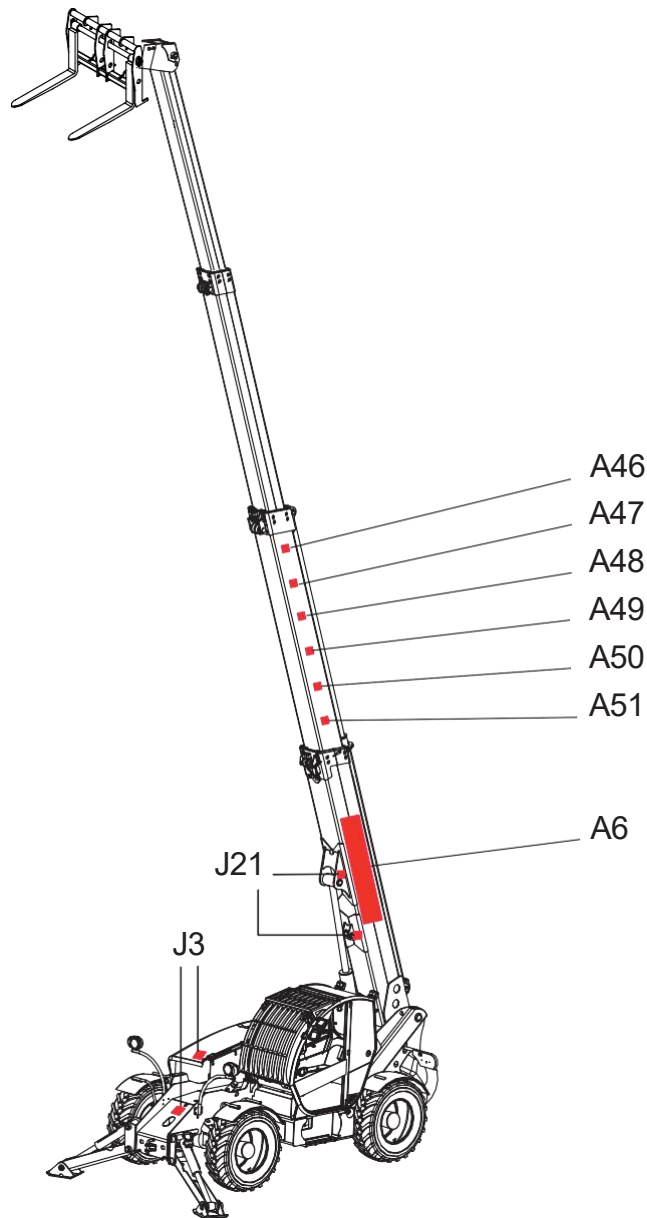

A

B

> C

D

E

F

G

H

I

# C - Pre-operation and controls

Localization: front view - HTL 8045 - HTL 8055 - Standards ANSI and CSA

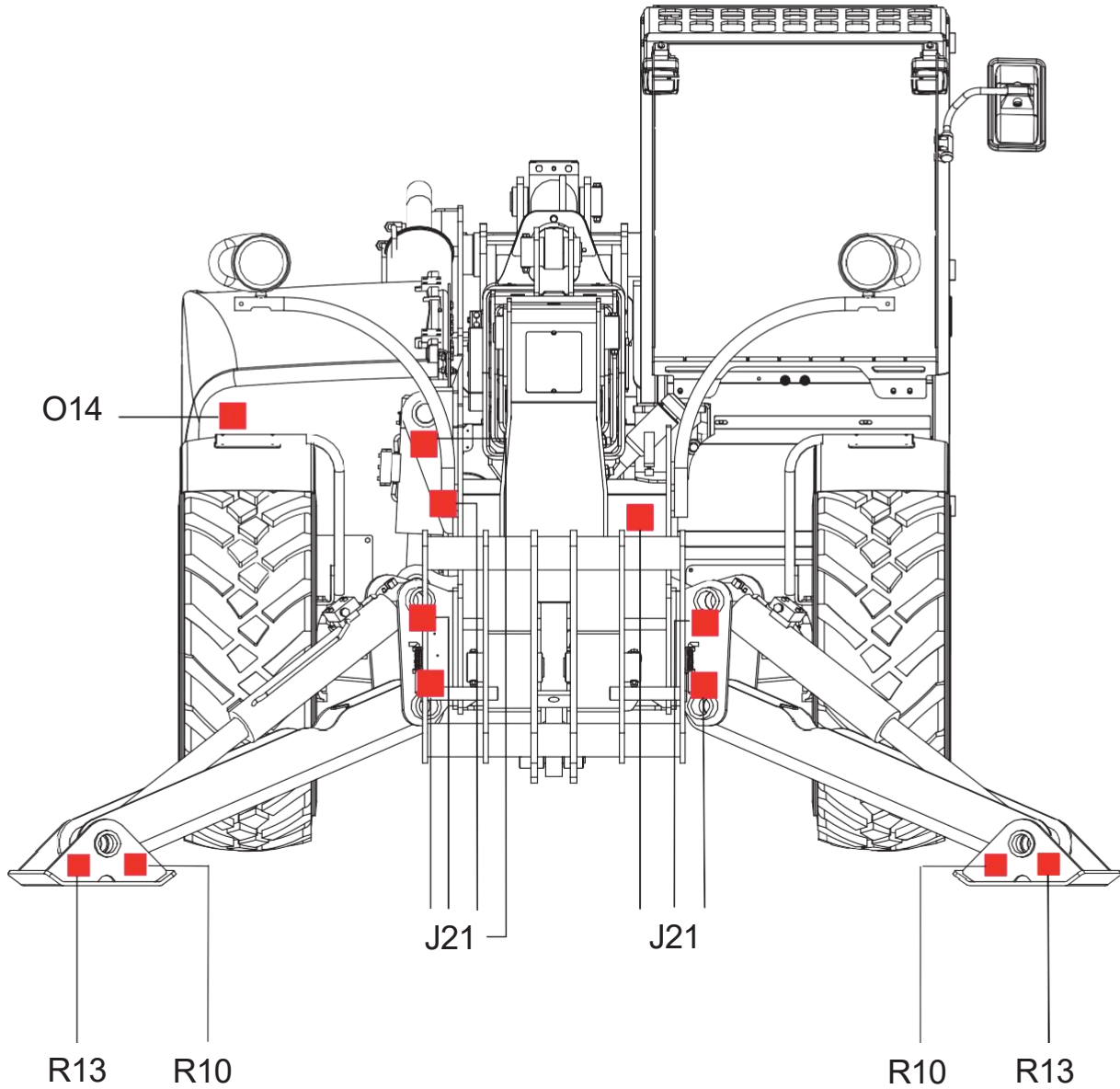

# C - Pre-operation and controls

Localization: left view - HTL 8045 - HTL 8055 - Standards ANSI and CSA

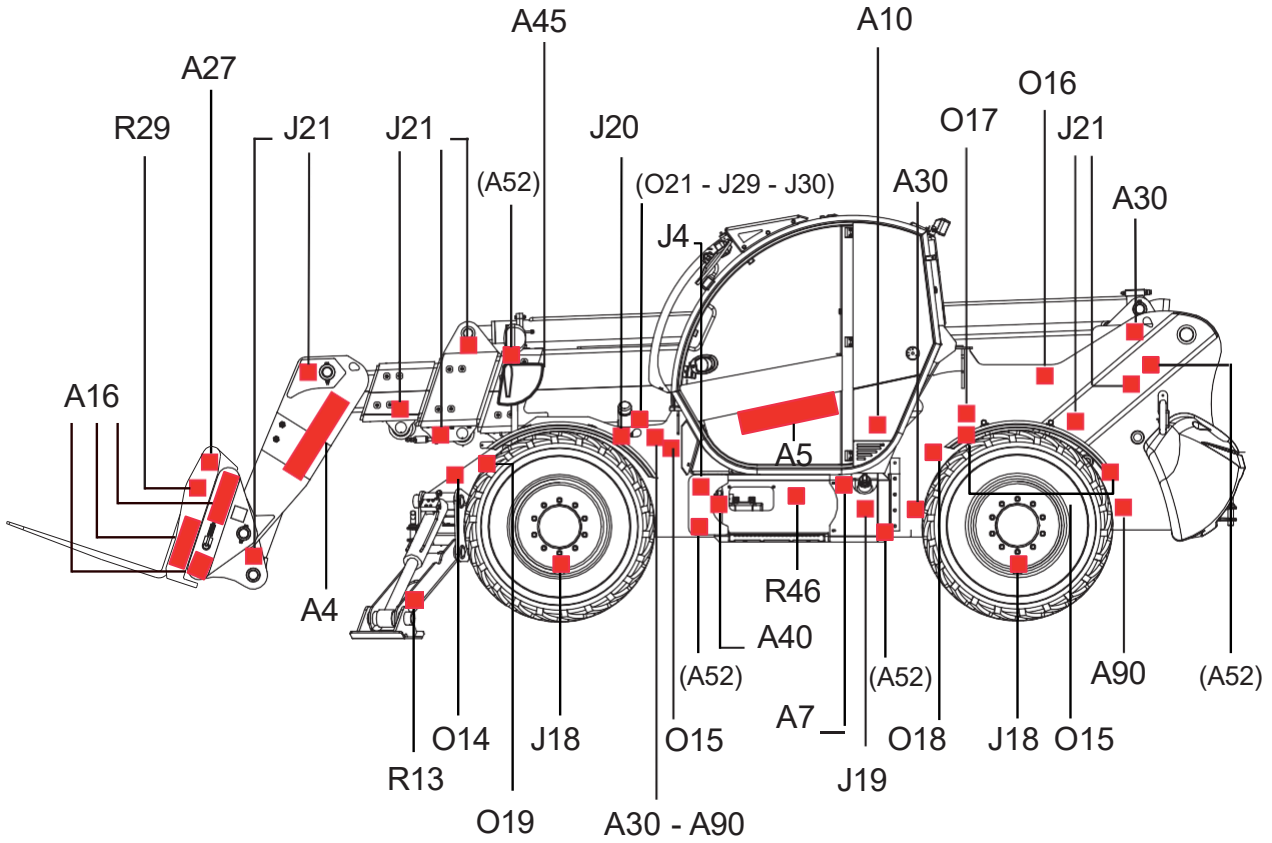

Localization: right view - HTL 8045 - HTL 8055 - Standards ANSI and CSA

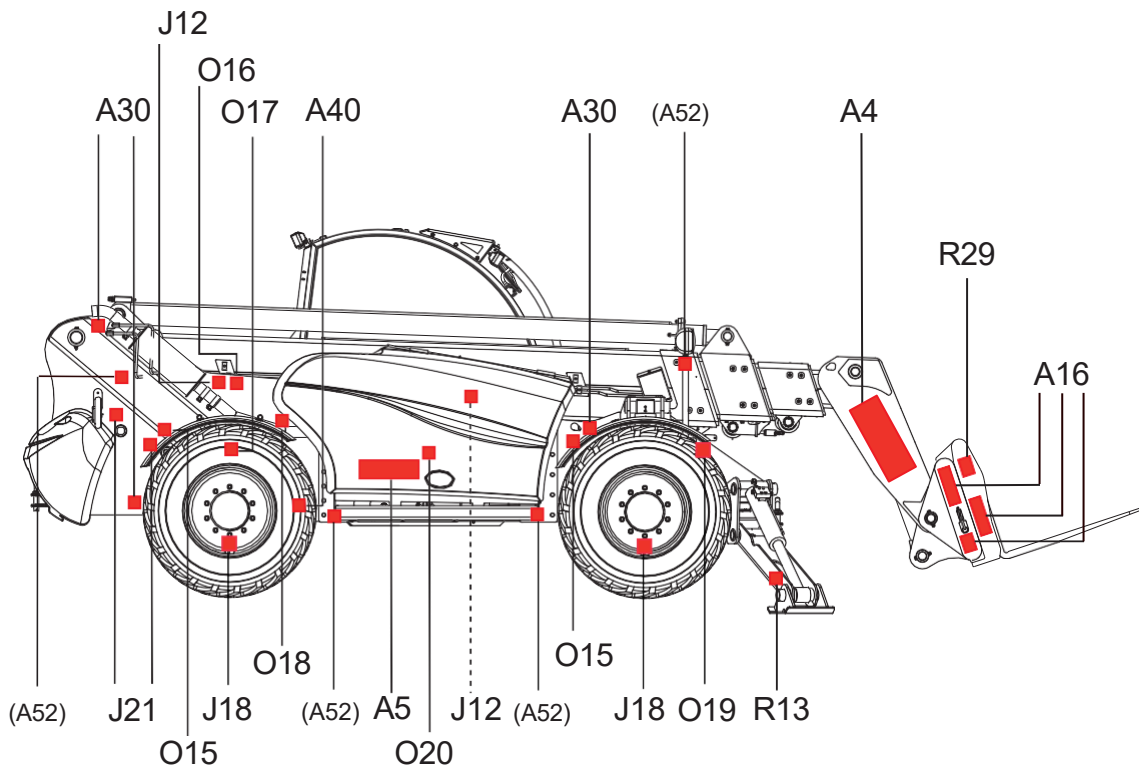

A

B

C

D

E

F

G

H

I

# C - Pre-operation and controls

Localization: cab view - HTL 8045 - HTL 8055 - Standards ANSI and CSA

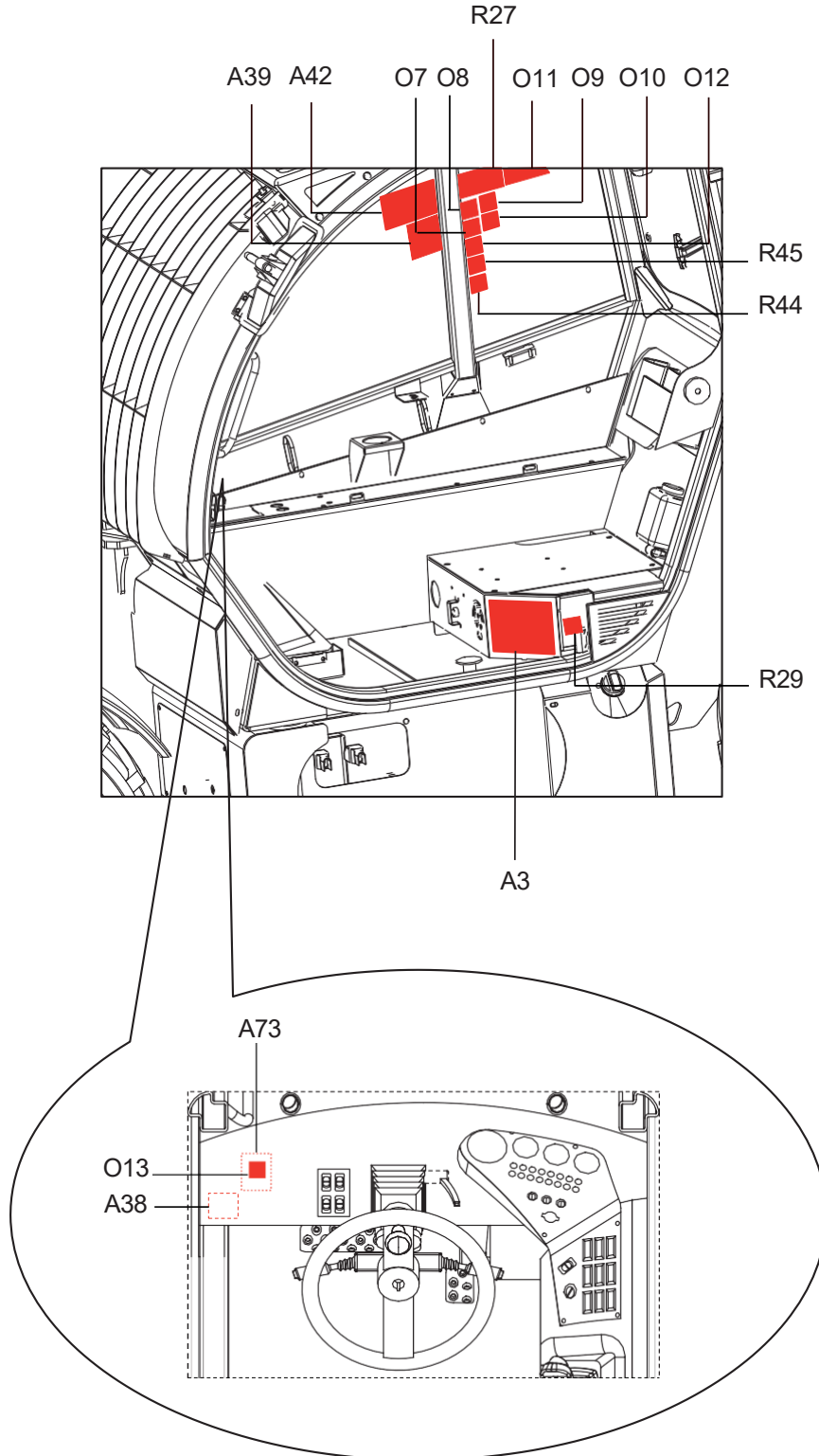

# C - Pre-operation and controls

Localization: view from above - HTL 8045 - HTL 8055 - Standards ANSI and CSA

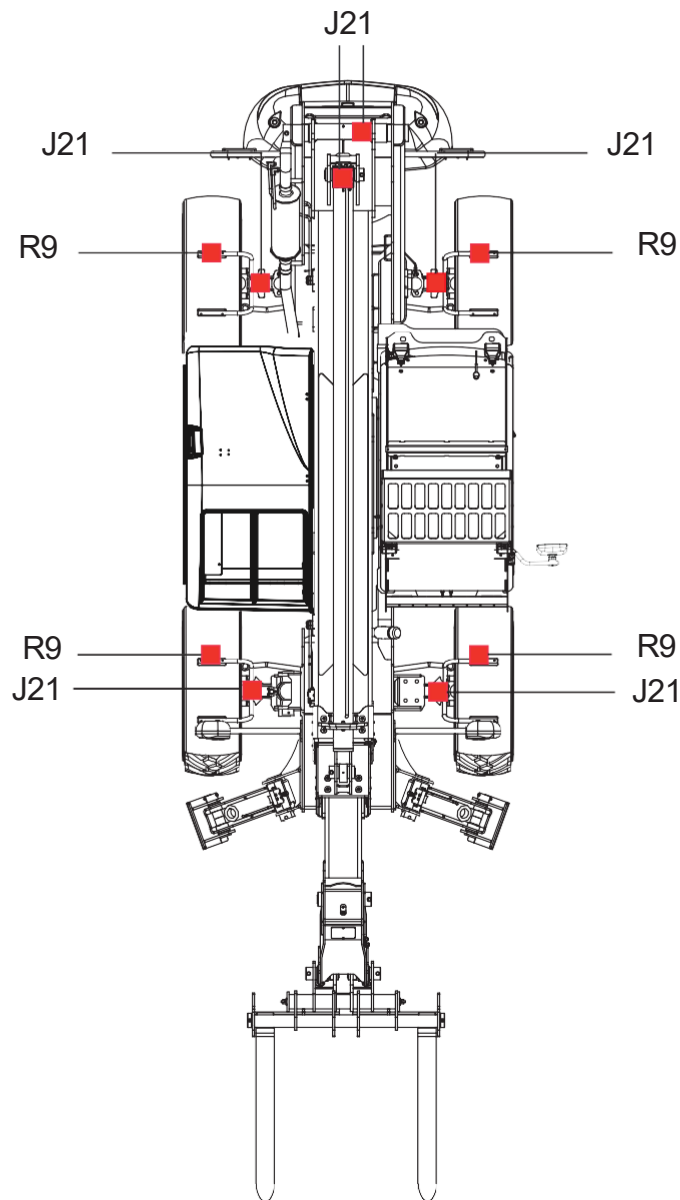

A

B

C

D

E

F

G

H

I

# C - Pre-operation and controls

Localization: rear view - HTL 8045 - HTL 8055 - Standards ANSI and CSA

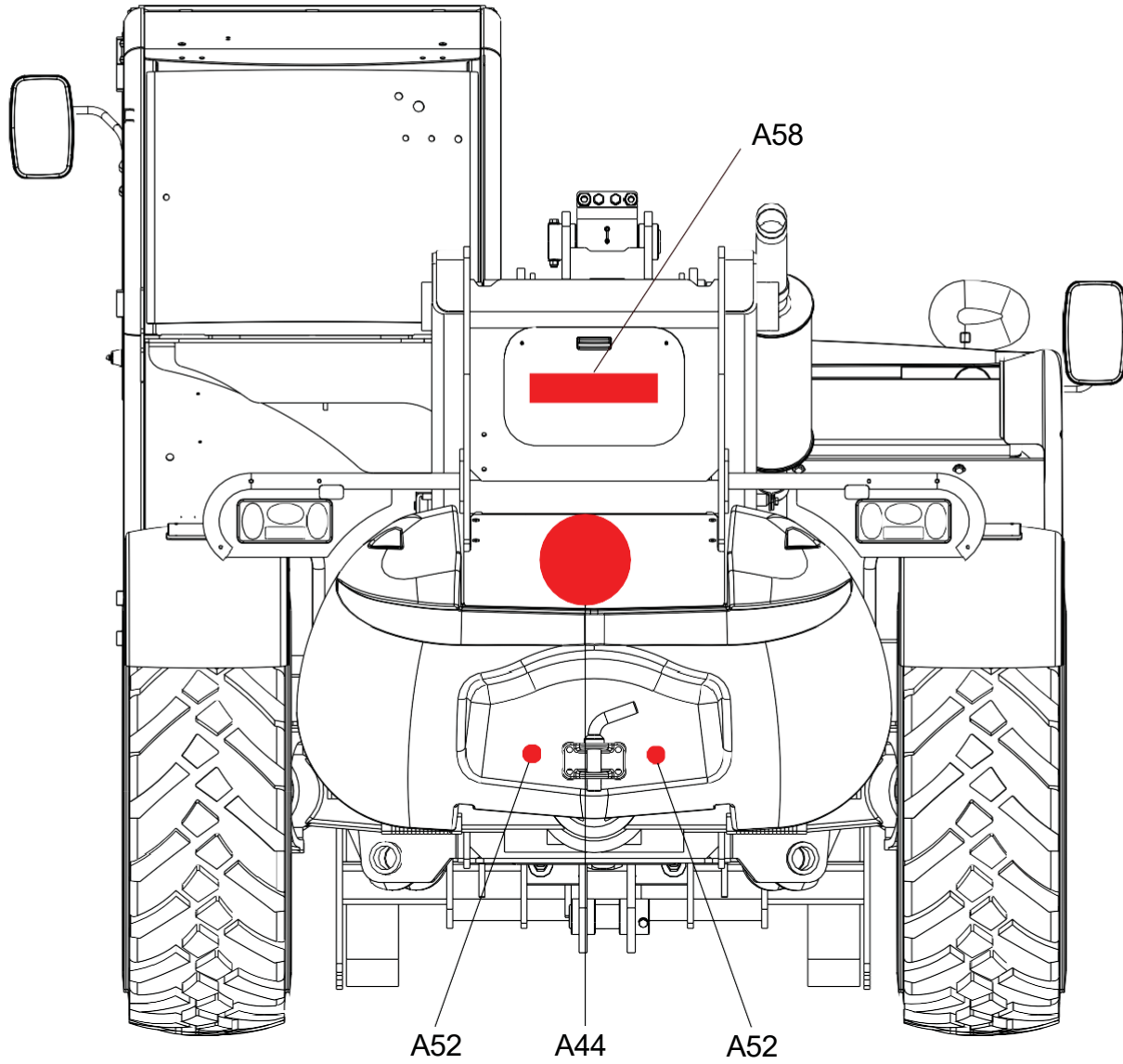

# C - Pre-operation and controls

## Common labels - Standards ANSI and CSA

Color	Marking	Description	Quantity	
Other	A3	Identification plate	1	307P224450
Other	A4	Machine name logo	2	For HTL 8045 : 4000104460 For HTL 8055 : 4000104860
Other	A5	Label HAULOTTE®	1	307P224740
Other	A6	Label HAULOTTE®	1	307P217770
Other	A7	Read the operation manual	1	307P225770
Other	A10	Noise emission level	1	4000053980
Other	A16	Yellow and black adhesive tape	1	2421808660
Other	A30	Slings attached	4	307P225530
Other	A38	Terminal fuses	1	4000023340
Other	A39	Joystick	1	307P226450
Other	A40	Battery / Battery isolation switch	1	307P225540
Other	A45	Angle sensor	1	307P220900
Other	A46	Telescoping key A	1	307P222610
Other	A47	Telescoping key B	1	307P222620
Other	A48	Telescoping key C	1	307P222630
Other	A49	Telescoping key D	1	307P222640
Other	A50	Telescoping key E	1	307P222650
Other	A51	Telescoping key F	1	307P222660
Other	A90	Anchor points on the machine	4	307P226100
Yellow	J3	Do not place your foot on the cover	2	307P225480
Yellow	J4	Ground for welding	1	307P225490
Yellow	J12	Danger of Heat burns	1	307P225410
Yellow	J18	Tyre pressure 4,5 bar (65,4 PSI)	4	307P225710
Yellow	J19	Fuel tank	1	307P225580
Yellow	J20	Hydraulic oil	1	307P225590
Yellow	J21	Lubrication	24	307P225600
Red	R9	Maximum effort on wheel	4	307P225500
Red	R10	Maximum effort on the stabilizers	2	307P225620
Red	R13	Risk of crushed feet	2	307P225400
Red	R27	Danger of electrocution	1	307P225340
Red	R29	Do not mount on the forks during elevation	1	307P225310
Red	R44	Risk of body crushing	1	307P225320
Red	R45	Boom in low position brake engaged	1	307P225370
Red	R46	Chemical burns hazards	1	307P225460
Orange	O7	Read the operation manual	1	307P225270
Orange	O8	Stay in the machine	1	307P225280
Orange	O9	Risk of overturning	1	307P225290
Orange	O10	Load falling hazards	1	307P225300
Orange	O11	Risk of overturning	1	307P225330
Orange	O12	Risk of overturning	1	307P225350
Orange	O13	Obligatory load chart	1	307P225360
Orange	O14	Risk of body crushing	2	307P225380
Orange	O15	Risk of body crushing	5	307P225390
Orange	O16	Risk of oil injection	2	307P225420
Orange	O17	Risk of crushed hands	1	307P225430
Orange	O18	Risk of body crushing	2	307P225440
Orange	O19	Load falling hazards	1	307P225450
Orange	O20	Mechanical risk	1	307P225470

# C - Pre-operation and controls

## Load capacity chart - Standards ANSI and CSA

Color	Marking	Description	Quantity	HTL 8045	HTL 8055
Other	A42	Load capacity chart	1	307P228560	307P228590
Other	A73	Load capacity chart - Book	1	171P346820	172P346700
Other		Load capacity chart - Cover book	1	4000497990	4000498120
Other		Load capacity chart Forks on wheels	1	4000501880	4000501890
Other		Forks on stabilisers Load capacity chart			
Other		Bucket for lifted stabilizers Bucket for lowered stabilizers	1	4000501810	4000501820
Other		Load capacity chart Double offset carriage on wheels	1	4000501960	4000501970
Other		Double offset carriage on stabilisers Load capacity chart			
Other		Jib crane 1 m 3 T on wheels Jib crane 1 m 3 T on stabilisers	1	4000507390	4000507400
Other		Load capacity chart Jib crane fitted swivel hook 2 m, 2 T lifted stabilisers	1	4000507480	4000507490
Other		Jib crane fitted swivel hook 2 m, 2 T lowered stabilisers Load capacity chart			
Other		Fly jib 2,5 m, 1,2 T lifted stabilisers Fly jib 2,5 m, 1,2 T lifted stabilisers	1	4000507600	4000507610
Other		Load capacity chart Fly jib 4 m, 0,6 T lifted stabilisers	1	4000507680	4000507690
Other		Fly jib 4 m, 0,6 T lowered stabilisers Load capacity chart			
Other		Winch 2,4 T lifted stabilisers Winch 2,4 T lowered stabilisers	1	4000507760	4000507770
Other		Load capacity chart Winch 1,2 T lifted stabilisers	1	4000507860	4000507870
Other		Winch 1,2 T lowered stabilisers Load capacity chart			
Other		Fork positioner for lifted stabilizers Fork positioner for lowered stabilizers	1	4000532130	4000532160
Other		Load capacity chart Bale spear 2 point for lifted stabilizers	1	4000555190	4000555200
Other		Bale spear 2 point for lowered stabilizers Load capacity chart			
Other		Bale spear 6 point for lifted stabilizers Bale spear 6 point for lowered stabilizers	1	4000555420	4000555460

# C - Pre-operation and controls

## 3.2 - OPERATOR'S CAB

The machine is equipped with an enclosed FOPS/ROPS cab.



Never use the machine unless the overhead guards and the cab structure are in good condition. Any modifications to this machine must be approved in writing by HAULOTTE® to ensure compliance with FOPS/ROPS certification for this cab/machine configuration. The cab cannot be repaired if it is damaged, It must be replaced.



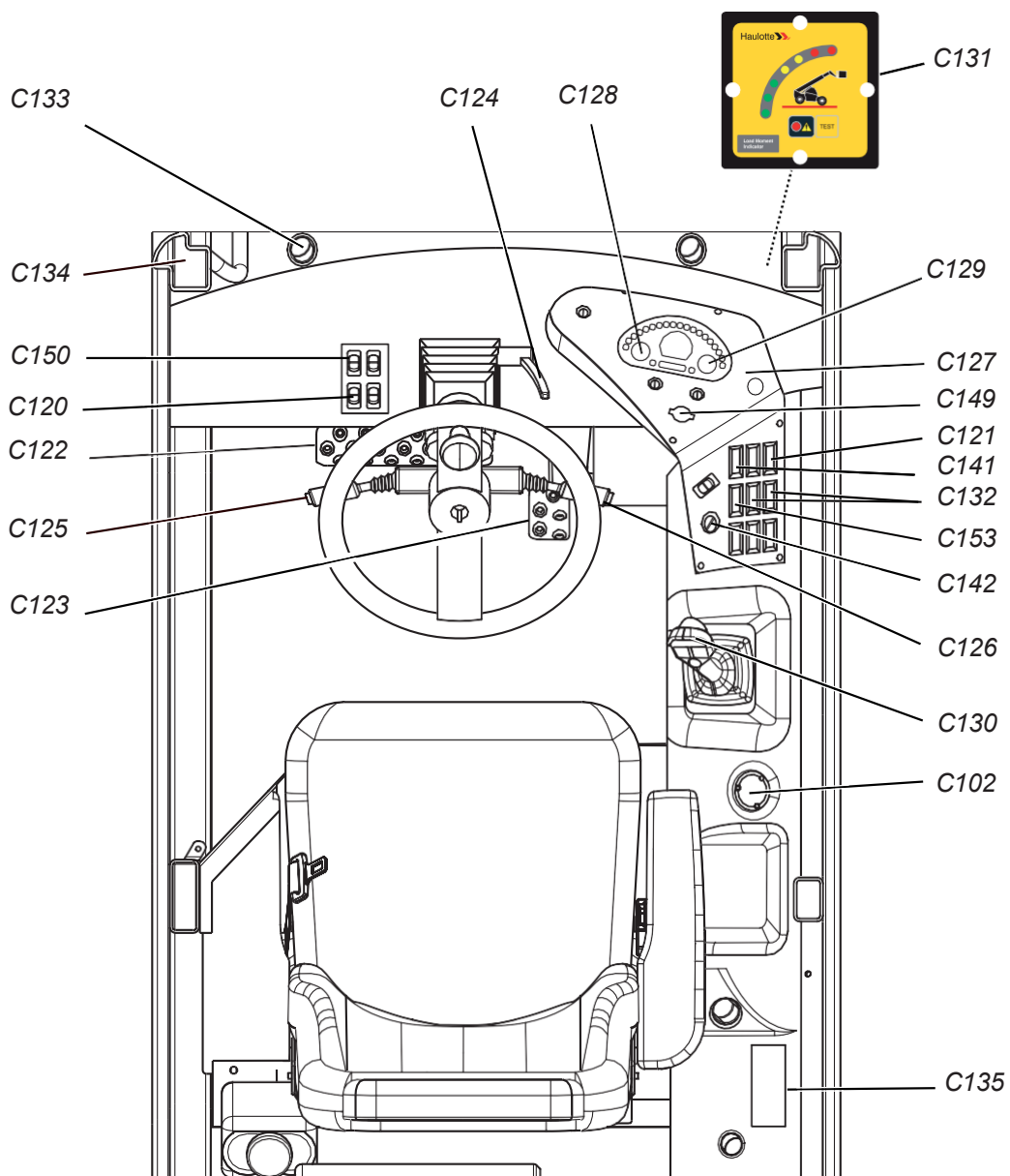

### 3.2.1 - Controls

General view



# C - Pre-operation and controls

## Description of the components

Marking	Description
C120	Warning lights
C121	Parking brake
C122	Brake pedal /Inching : The further the pedal is pressed, the slower the travel speed
C123	Accelerator pedal : Press on the pedal to increase the engine speed and the hydraulic fluid flow
C124	Steering column adjuster :  Section C 2.5.3 - Steering column
C125	Transmission control lever :  Section C 2.5.3 - Steering column
C126	Headlight, indicator and buzzer control
C127	Indicator and control box : Controls and indicates certain machine functions. Displays engine speed.  Section C 2.5.7 - Instrument/control panel
C128	Fuel gauge : Indicates fuel level in tank
C129	Engine temperature gauge
C130	Joystick :  Section C 2.5.8 - Joystick
C131	Load moment indicator display :  Section C 2.5.10 - Load moment indicator display
C132	Heating and air-conditioning control
C133	Adjustable air vents: Individual controllable
C134	Air louvers: Individual adjustable
C102	Dumping
C135	Car radio
C141	Road mode
C142	Rear-axle steering
C149	Ignition key
C150	Fog lights
C153	Windscreen washer

**N.B.-:** The functions are described for the entire range. Refer to the machine model to identify the controls and functions indicators.

# C - Pre-operation and controls

## 3.2.2 - Pedals

General view

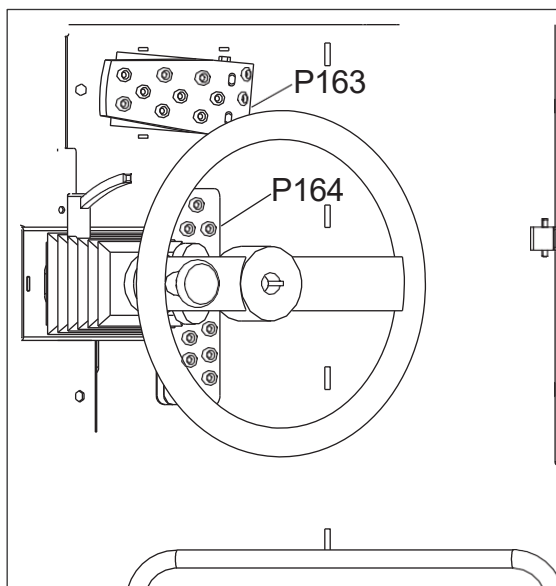

Pedals

Marking	Description	Function
P163	Accelerator	Pedal for increasing the engine speed
P164	Brake	Machine braking Inching : Slow approach

A

B

C

D

E

F

G

H

I

# C

 - Pre-operation and controls

## 3.2.3 - Steering column

### General view

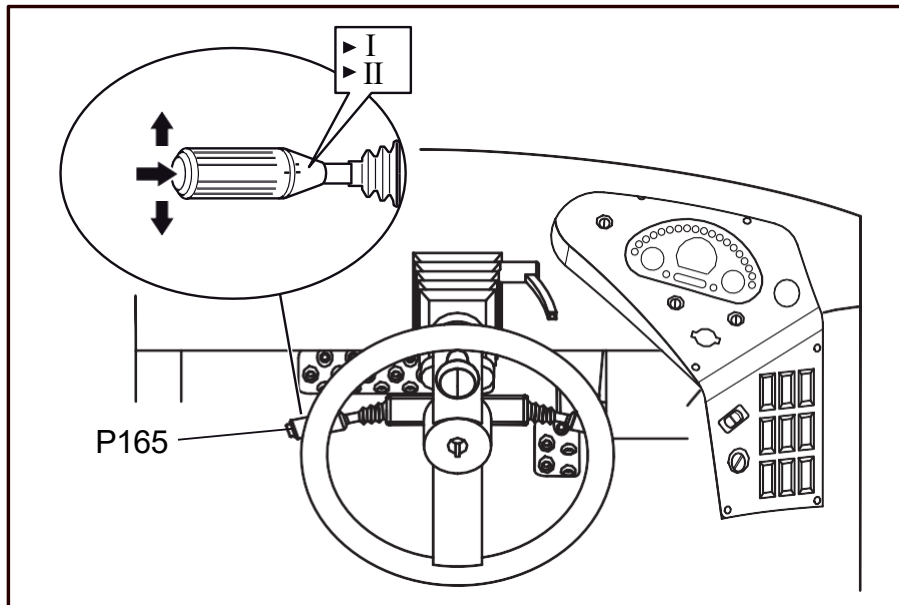

### Left-hand control lever

Marking	Description	Function
P165	Gear and movement direction control	Speed selection : <ul style="list-style-type: none"> <li>• Neutral</li> <li>• Slow speed : Selector in position I</li> <li>• Fast speed : Selector in position II</li> </ul> <hr/> Travel direction selection : <ul style="list-style-type: none"> <li>• Forward drive : Pull the lever backwards and then push it upwards</li> <li>• Neutral</li> <li>• Reverse drive : Pull the lever backwards and then pull it downwards</li> </ul>

Forward and reverse can be selected while in slow or fast speed.



**A sudden change of direction could destabilise the machine and/or cause the load to tip over or fall.**

**When reverse drive is activated, a audible sound warns that the machine is in reversing mode and warns of potential danger anyone present in the manoeuvring area.**

**Reverse mode of travel should only be selected whilst the machine is stationary.**

# C - Pre-operation and controls

General view

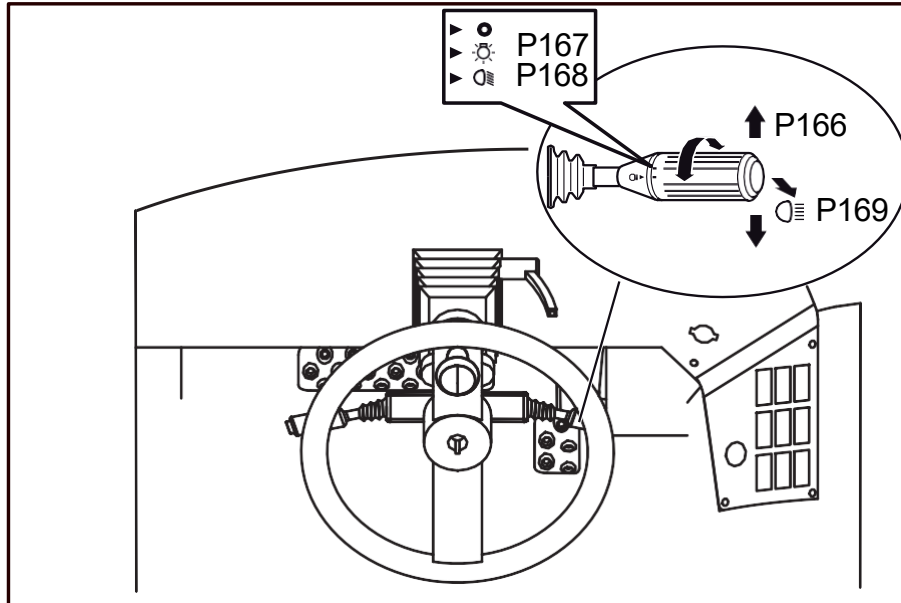

Right-hand control lever

Marking	Description	Function
P166	Turn signals/Direction indicators	Left-hand steering : Raise the lever Right-hand steering : Lower the lever
P167	Sidelights	On : Turn clockwise Off : Turn anti - clockwise (ACW)
P168	Headlights	On : Turn clockwise Off : Turn anti - clockwise (ACW)
P169	Full beam headlights	On : Push forward Off : Pull backward Flashing the lights : Pull backward in short bursts

### 3.2.3.1 - Steering column adjustment



Bring the Telehandler to a complete stop and shutdown the engine before adjusting the steering column. A sudden change of direction could destabilise the machine and/or cause the load to tip over or fall. "Failure" to comply with these instructions could result in death or serious injury.

Adjust the steering column as follows :

- Push the lever down to release the steering column.
- Move the steering wheel to the required position.
- Lock the steering column by pulling the lever up.

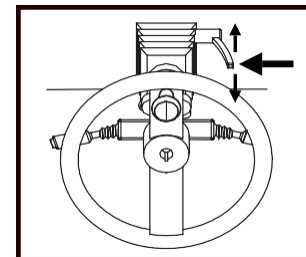

# C

## - Pre-operation and controls

### 3.2.4 - Operator's seat

General view

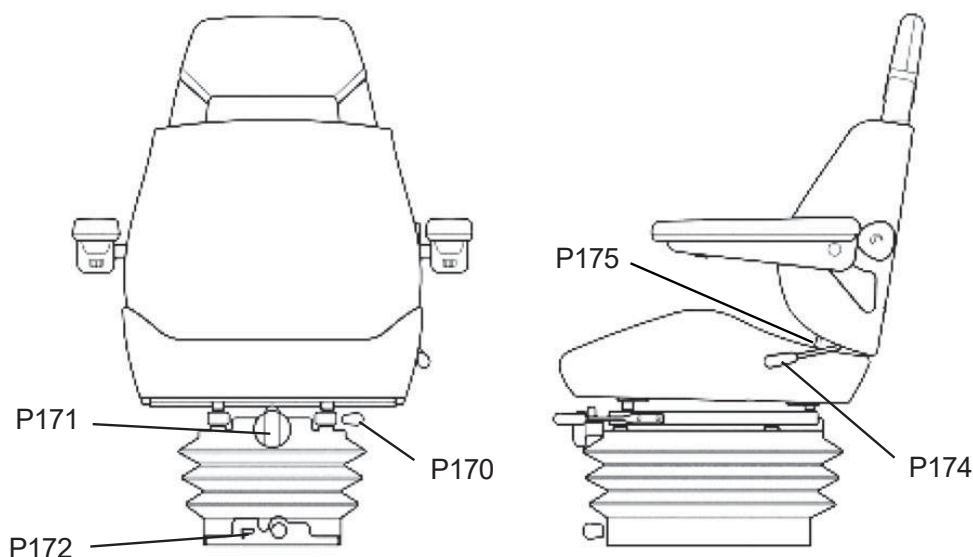

General view



Before starting the engine, adjust the seat as follows to place the seat in an appropriate and comfortable position :

- Move forward/backward : Use the handle ( P170 ) to move the seat forward and backward.
- Height : Use knob ( P171 ) to adjust the seat height.
- Suspension : Use the knob ( P172 ) to adjust the suspension to the appropriate weight :
  - In the green zone : Suspension is adapted to the operator's weight.
  - In the red zone : The suspension is not adapted to the operator's weight.
- Backrest : Use the button ( P174 ) to adjust the backrest angle.
- Seat belt : Always fasten the seat belt ( P175 ) when operating the machine.

# C - Pre-operation and controls

## 3.2.5 - Heating and ventilation

The cab is equipped with a heater that is also used for de misting the windscreen.

The air is circulated via a two-speed fan. To activate the fan, press the heating fan switch ( P203 ) on the side instrument panel.

Adjust the heating temperature using the knob under the driver's seat.

Adjust the air flow using the air locks and round vents.

### Heating and ventilation

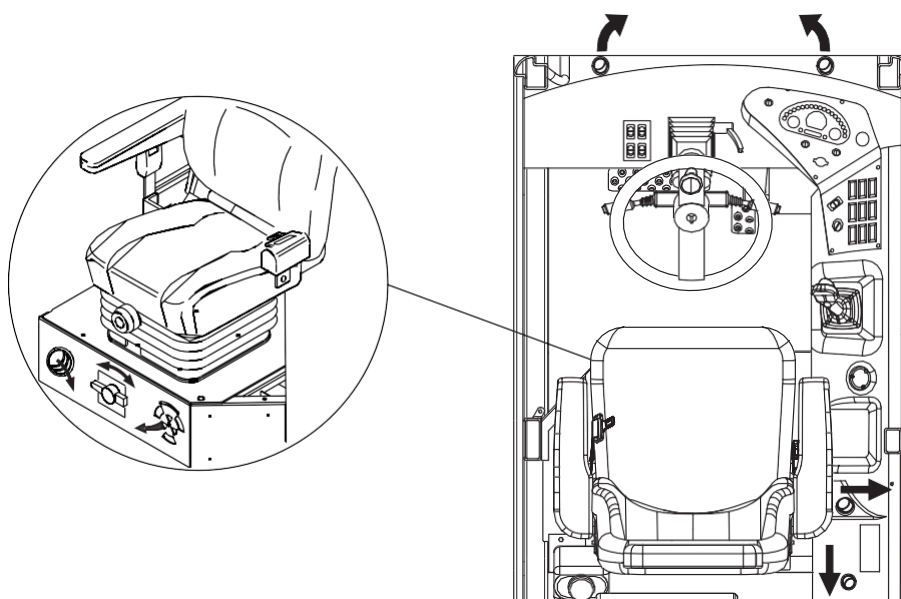

Do not operate the Telehandler for an extended period without ventilating the cab via the ventilation system.



Always ensure proper ventilation.

A lack of proper ventilation in the cab during use can lead to driver tiredness (oxygen deprivation).

# C - Pre-operation and controls

## 3.2.6 - Air-conditioning(Optional)

To activate the air conditioning, operate the switch ( P207 ) located on the lateral control console.



**The heating must be off when the air conditioning is on.**



**This equipment should not be started before starting the thermal engine.**



**Do not start the Telehandler engine while the air conditioning is switched on.**

Adjust the fan speed.

Adjust the air flow using the air locks and round vents.

# C - Pre-operation and controls

## 3.2.7 - Instrument/control panel



A

B

C

D

E

F

G

H

I

# C - Pre-operation and controls

## Instrument/control panel

Marking	Description	Function
P198	Exclusion key in fork/winch mode (Option)	Folds the machine in case of anti-tipping alarm : Rotate to right and hold
	'Enable Switch' selector in platform mode (Option)	Control of the platform from the cab : Rotate to right and hold
	Emergency pump in platform mode (Option)	Operation of the emergency pump : Rotate to right and hold
P199	3-position ignition key	Position 0 : Machine shutdown
		Position 1 : Ignition
		Position 2 : Starter
P221	Fork/Winch/Platform Selector (Option)	Fork position : Center
		Winch position : Rotate to left
		Aerial lift position : Turn right
P222	Radio-control selector / Cab selector (Option)	Radio-control position : Rotate to left
		Cab position : Turn right
P223	Emergency stop button (Option)	Pulled out (activated) : Contact closed ON
		Pushed down (deactivated) : Contact open OFF

# C - Pre-operation and controls

## Display

### General view

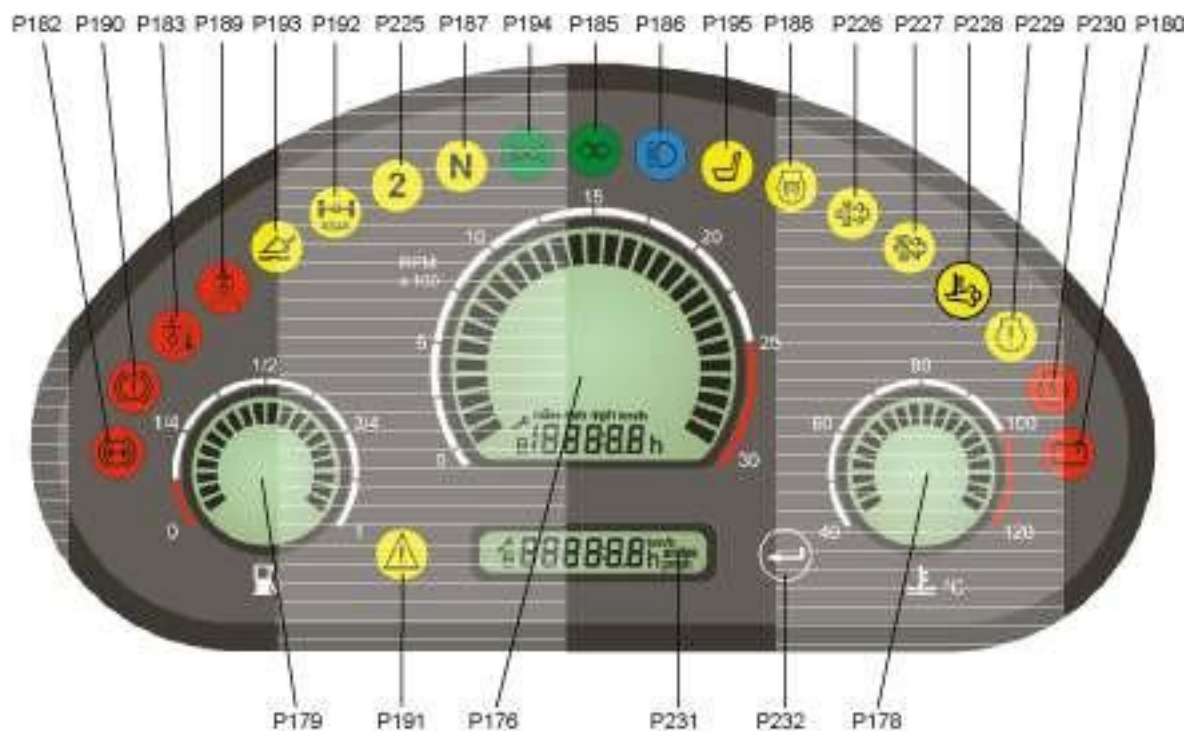

### Display

Marking	Description	Function
	Service counter (when power is switched on)	Number of hours to next service
P176	Engine tachometer with hour meter	Engine revs indicator graduated from 0 to 3100 tr/min (3100 RPM) <sup>1</sup> Vehicle speed (Km/h)
P178	Engine temperature indicator	Flashing : Coolant temperature <sup>2</sup>
P179	Fuel level gauge	Flashing : Low fuel level
P180	Battery LED	On : Battery charge problem
P182	Parking brake defect LED	On : Parking brake fault
P183	Hydraulic oil temperature indicator	On : Hydraulic oil temperature too high
P185	Steering indicator	Flashing : Left-hand or right-hand steering activated
P186	Headlight indicator	On : Headlights on
P187	Neutral LED	On : Drive in neutral position
P188	Engine pre-heating LED	On : Engine pre-heating
P189	Hydraulic oil filter LED	On : Hydraulic oil filter clogged
P190	Service brake fault LED	On : Service brake fault or parking brake engaged
P191	Machine fault indicator	Flashing : One or more faults detected and/or active OR machine maintenance to be performed <sup>3</sup>
P192	Rear axle alignment LED	On : Rear wheels aligned
P193	LED floating(Optional)	On : Activated Flashing : Floating lift selected but not validated
P194	Side clearance light LED	On : Side lights on
P195	Seat occupied LED	On : Seat presence not detected
P225	Drive speed 2 indicator <sup>4</sup>	On : Speed 2 engaged Flashing : High speed requested but not validated

# C - Pre-operation and controls

Marking	Description	Function
P226	Diesel particulate filter regeneration indicator (For machines fitted with engine PERKINS 854E-34TA only)	On : Automatic or manual (forced) regeneration of the particulate filter is required <sup>5</sup>
		On + P229 Flashing : Manual (forced) regeneration of the particulate filter is required <sup>6</sup>
		On + P229 Flashing + 230 On : Necessary change of diesel particulate filter <sup>7</sup>
P227	Particulate filter regeneration disabled indicator (For machines fitted with engine PERKINS 854E-34TA only)	On : Automatic particulate filter regeneration disabled
P228	High exhaust gas temperature indicator (HEST) (For machines fitted with engine PERKINS 854E-34TA only)	On : Particulate filter regeneration in progress
P229	Engine warning	On : Drive motor faulty OR machine maintenance to be performed 5 flashes when switched on : machine maintenance to be performed in 20 h maximum
P230	Engine shutdown	On : Serious engine fault
P231	Fault codes <sup>8</sup>	One or more faults detected and/or active <sup>3</sup>
	Machine counters (hour or service)	Total machine running hours Number of hours to next service
P232	Navigation button	In case of machine fault, each press on the button scrolls through the fault codes
		In the absence of machine fault, each press on the button navigates between the hour counter and the service counter

<sup>1</sup> : Do not exceed 3100 tr/min (3100 rpm). Do not run the engine speed into the red zone.

<sup>2</sup> : Service the machine as set out in this manual (  Section H - Lubrication and maintenance).

<sup>3</sup> : The (P191) indicator flashes to indicate an internal malfunction.

When the machine switches downgraded mode, certain movements can be limited or prohibited to safeguard the operator's well being (  Section H 21 - Troubleshooting).

<sup>4</sup> : Condition for prohibiting action : Extended boom or active float option or service brake pressure fault.

<sup>5</sup> : The level of clogging of the particulate filter requires regeneration. Disabled mode must be deactivated rapidly, as soon as the environment allows it (outside areas with explosive atmosphere).

<sup>6</sup> : High level of particulate filter clogging.

<sup>7</sup> : The particulate filter is clogged.

<sup>8</sup> : Description of fault codes :  Section H 21 - Troubleshooting.

# C - Pre-operation and controls

## Right-hand control panel

### General view

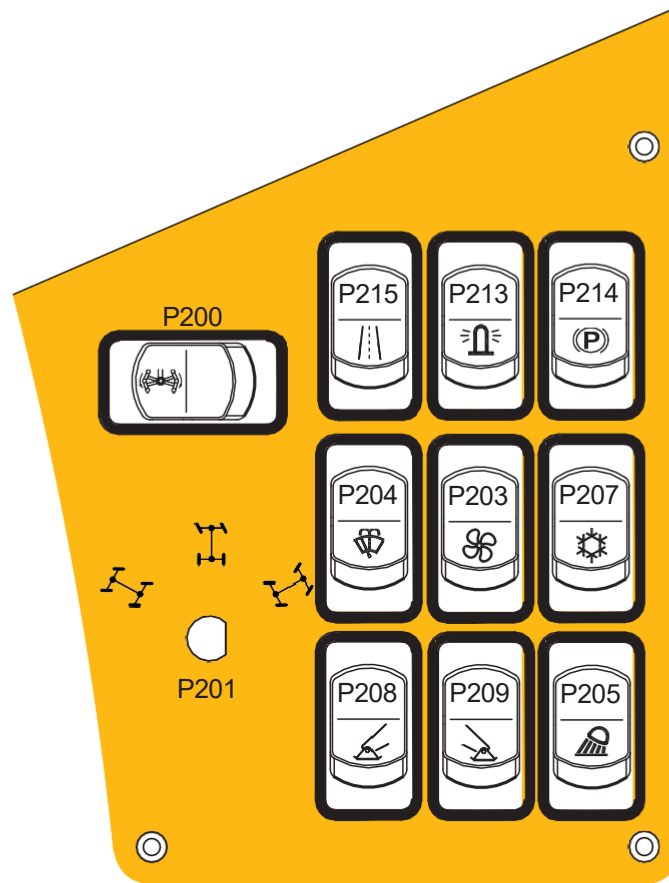

Right-hand control panel

Marking	Description	Function
P200	Chassis leveling switch	Move to the left : tilt to the left Move to the right : tilt to the right
P201	Rear axle selection Steering mode <sup>1</sup>	Synchronised axle
		Front steer wheels
		Crab mode axle
P203	Heating/Ventilation switch	Ventilation - 2 speeds Activated : Press top of switch downwards
P204	Windscreen wiper switch	Deactivated : Press bottom of switch downwards Windscreen washer : Press bottom of switch downward fully
P205	Work light switch (Option)	On : Press top of switch downwards Off : Press bottom of switch downwards
P207	Air-conditioning switch (Option)	Activated : Press top of switch downwards Deactivated : Press bottom of switch downwards
P208	Left stabiliser switch	To lower left stabiliser : Press bottom of switch downwards To raise the left stabiliser : Press top of switch downwards
P209	Right stabiliser switch	Right stabiliser lowering : Press bottom of switch downwards Right stabiliser lifting : Press top of switch downwards

# C - Pre-operation and controls

Marking	Description	Function
P213	Beacon switch	On : Press top of switch downwards Off : Press bottom of switch downwards
P214	Parking brake switch <sup>2</sup>	Activated : Press top of switch downwards Deactivated : Press bottom of switch downwards
P215	Road mode selection switch	On : Press top of switch downwards Off : Press bottom of switch downwards



The stabilisers only increase stability and load capabilities if they are used correctly. Using stabilisers on soft surfaces can cause the machine to tip over which can result in serious injury. Always make sure that the surface on which the machine operates, is capable of supporting the combined weight of the machine and the load.

Stabiliser switches ( P208 ) and ( P209 ) are equipped with a warning light. A stabiliser can only be moved if this indicator is lighted. If this indicator is off, retract and lower the telescopic arm until the indicator lights up in order to move the stabiliser.

# C - Pre-operation and controls



1 :

**For high-speed driving and any driving on public roads :**

- Only use the "Front steer wheels" mode.
- Check the alignment of the rear wheels : The "Rear wheels aligned" indicator (P192) must be switched on.

**Axes must be realigned :**

- At the start of each day.
- At least once a day.
- If a misalignment problem is observed between the front and rear axles.

**Follow the instructions below to realign the driving system :**

1. Select the "Front steer wheels" mode. Rotate steering wheel slowly to bring the rear wheels to the right position. The "Rear wheels aligned" indicator (P192) must be switched on. Continue to rotate steering wheel slowly until you see the front wheels aligned.
2. Select the "Synchronised axle" mode again. Check the realignment by carefully driving the machine a short distance.

2 :

***N.B.-:-The parking brake is automatically applied when the engine is switched off.***



**Parking brake switch :**

- Respect the activation mode: locking /unlocking.
- Do not force the activation mode.

**In road mode :**

- All boom movements are prohibited (joystick deactivated).
- Using the stabilizers and dumping is prohibited.
- Steering switches to "2 steering wheels" mode, whatever the position of the steering selector may be (with the rear axle automatically returning to road position).
- Overriding the steering function with the exclusion key is also deactivated.

**To switch to road mode, you must :**

- Have the stabilizers raised
- Have stowed the machine

If these conditions are not respected and the road mode is selected, travelling is deactivated. The road mode indicator ( P215 ) flashes to failure to comply with the conditions. If the stabilisers are not raised,the stabilizer LED ( P208 ) and ( P209 ) also flash. Once the conditions are met, indicator ( P215 ) comes on and driving is enabled at high and low speeds.

# C - Pre-operation and controls

## 3.2.8 - Joystick

General view - ANSI standard

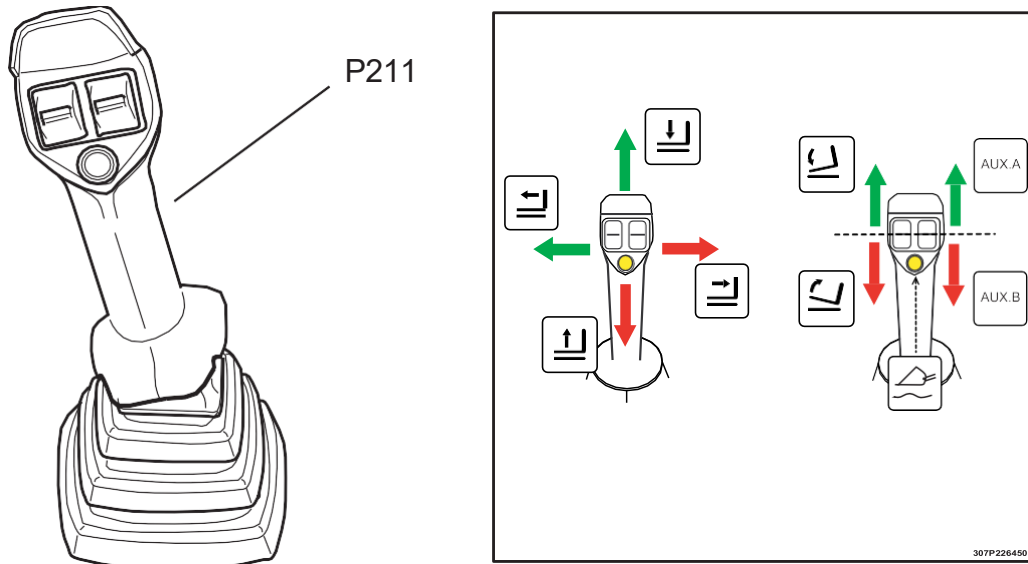

Joystick - ANSI standard

Marking	Description	Function
P211	Joystick	To raise the telescopic arm : Pull the joystick To lower the telescopic arm : Push the joystick To telescope out : Push the joystick to the left To telescope in : Push the joystick to the right Discharging : Push the left rocker switch upwards Crowding : Push the left rocker switch downwards Auxiliary, direction A : Push the right rocker switch upwards Auxiliary, direction B : Push the right rocker switch downwards Button : Float option

The speed of the joystick functions depends on the amplitude of the joystick travel in the corresponding direction. Increasing the engine speed also increases the function speed.



**Rapid, jerky operation of the controls causes rapid and jerky machine movements. Such movements can cause the load to drift or fall and the machine may tip over. "Failure" to comply with these instructions could result in death or serious injury.**

# C - Pre-operation and controls

## 3.2.9 - Left-hand control panel

General view

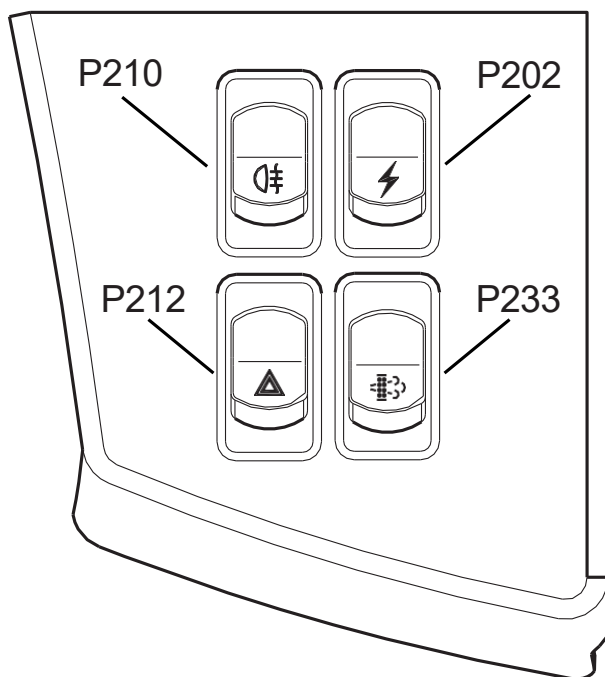

General view

Marking	Description	Function
P202	12 V socket switch (Option)	
P210	Rear fog lights switch	On : Press top of switch downwards Off : Press bottom of switch downwards
P212	Hazard warning lights switch	On : Press top of switch downwards Off : Press bottom of switch downwards
P233	Particulate filter regeneration switch (For machines fitted with engine PERKINS 854E-34TA only)	Drive in neutral position : Automatic regeneration mode Push upwards : • Push upwards once and hold for 2 seconds minimum : Particulate filter regeneration disabled (mode compulsory in areas with explosive atmosphere). The ( P227 ) indicator lights up. • Press upwards a second time and hold for 2 seconds minimum : Reactivation of particulate filter regeneration (mode compulsory in areas with explosive atmosphere). The ( P227 ) indicator goes off. Press downwards : Start of forced particulate filter regeneration • Press downwards and hold for 2 seconds minimum : Start of manual (forced) regeneration outside areas with explosive atmosphere. The ( P228 ) indicator lights up if the following conditions for performance are satisfied : • The ( P226 ) indicator is lit. • Engine running for over 10 seconds and idling. • Engine temperature greater than 65 °C(149 °F) (engine temperature indicator ( P178 )). • Parking brake activated. • Translation in neutral position.

# C - Pre-operation and controls



While a forced regeneration is running, it is essential to be aware of the following points :

- The machine is immobilised for 15 20 minutes (until the ( P228 ) indicator goes out).
- The engine speed increases to 2000 tr/min.

If a significant problem arises, regeneration can exceptionally be interrupted in the following ways :

- Pressing the accelerator pedal.
- Parking brake deactivation (P214).
- Translation activated in forward or reverse.
- Engine switched off using the ignition key.



**DANGER OF BURNS!** During regeneration, the temperature of the exhaust gases is high and may reach 650 °C(1202 °F) .



Always start the engine and run it in a well-ventilated area. If the engine is in an enclosed space, vent the exhaust gases outside.



Do not run the engine in a place where there is a risk of build up of toxic gases.

# C - Pre-operation and controls

## 3.2.10 - Load moment indicator (LLMI)

### General view

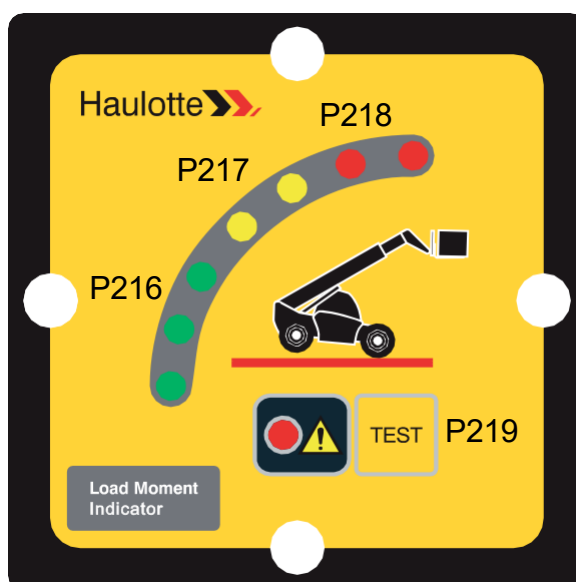

### Controls and indicators

Marking	Description	Function
P216	Green LED's	Loading percent
P217	Yellow LED	Pre-alarm (intermittent buzzer)
P218	Red LED	Alarm (continuous buzzer)
P219	Test	The indicator can be tested at any time



The machine is fitted with an impending forward stability limit indicator. This indication is only valid on flat ground with the machine halted and the rear wheels aligned.

A display set into the right-hand windscreen strut shows the percentage remaining load, triggers a pre-alarm, reduces movement speed and then disables boom lowering and extension movements.

Test the load moment indicator at the start of each work period (📖 Section H - Lubrication and maintenance)

In all cases, the load capacity chart supplied in the cab is the only reference which may be used to define load capacity and ensure that the machine operates correctly. Even a lit green LED does not authorise the machine to be used without the load chart or the load capacity to be moved.

If a load moment indicator system alarm is triggered, the following movements are disabled :

# C - Pre-operation and controls

## Movements-Modes

Movement	Fork mode	Winch mode	Platform mode
Booms raising	Authorized	Prohibited	Authorized
Boom lowering	Deactivated if the alarm sounds but can be activated with the exclusion key	Prohibited	Deactivated if the alarm sounds but can be activated with the exclusion key
Crowding	Deactivated if the alarm sounds but can be activated with the exclusion key	Prohibited	Deactivated if the alarm sounds but can be activated with the exclusion key
Discharging	Deactivated if the alarm sounds but can be activated with the exclusion key	Prohibited	Deactivated if the alarm sounds but can be activated with the exclusion key
To telescope in	Authorized	Prohibited	Authorized
To telescope out	Prohibited	Prohibited	Prohibited
Attachments	Deactivated if the alarm sounds but can be activated with the exclusion key		
Driving	Authorized		

Temporary suspension of the Load Moment Indicator system :

An exclusion key ( P198 ) allows the operator to disregard this movement deactivation to avoid being blocked in certain configurations. In this case, the operator should knowingly takes responsibility for the for the machine's stability. This function is automatically deactivated after 8 s of activation in the absence of movement. It must be released before in can be reactivated.



**When the Load Moment is deactivated, the machine stability is no longer guaranteed. Consequently, there is a risk of the machine tipping over. The operator therefore assumes full responsibility for the machine's movements and must be aware of the consequences of his actions.**

# C - Pre-operation and controls

## 3.2.11 - Rear-view mirrors and windows

Cab door window :

The window must be blocked in open or closed position during use.

Open the cab door window and block it with the locking mechanism.

Press the unlocking button in the cab to unlock the window.

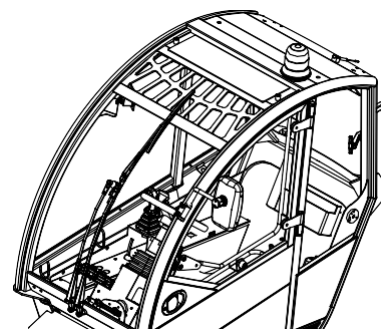

Rear window

Pull the lever and push to open the rear window.

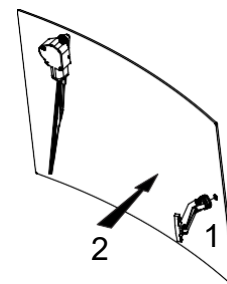

# C - Pre-operation and controls

## Rear-view mirror adjustment

The machine is fitted with 5 mirrors :

### Locations

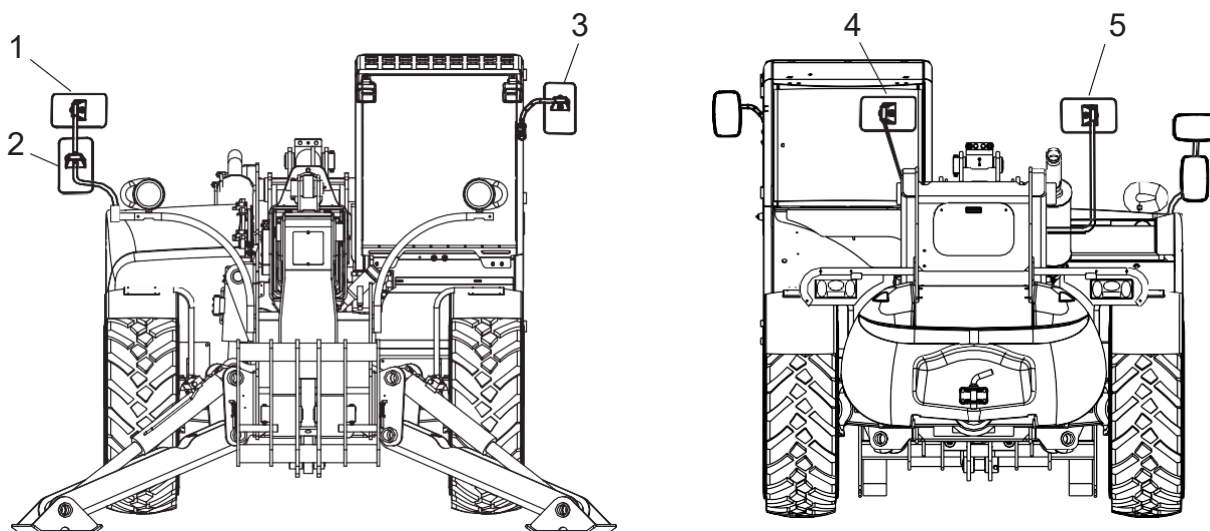

### Visibility zone

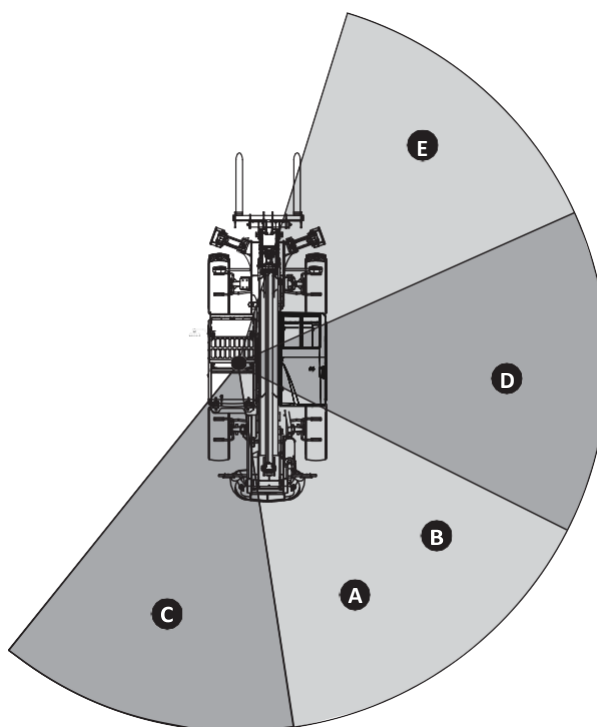

### Description of the components

Mirrors	Visibility in zone
1	A
2	B
3	C
4	D
5	E

# C - Pre-operation and controls

Rear-view mirror adjustment :

Rotate the mirror on the axle on which it is fitted.



**Adjust the rear-view mirrors as required for optimal visibility before and during use.**



**Ensure that rear-view mirrors are clean and clear at all times.**



**Before each use of the machine, ensure that the mirrors are not damaged.**



**Any modifications to this machine can affect the visibility in driving position.**



A

B

C

D

E

F

G

H

I

# C - Pre-operation and controls

## 3.3 - RADIO-CONTROL EMITTER

General view

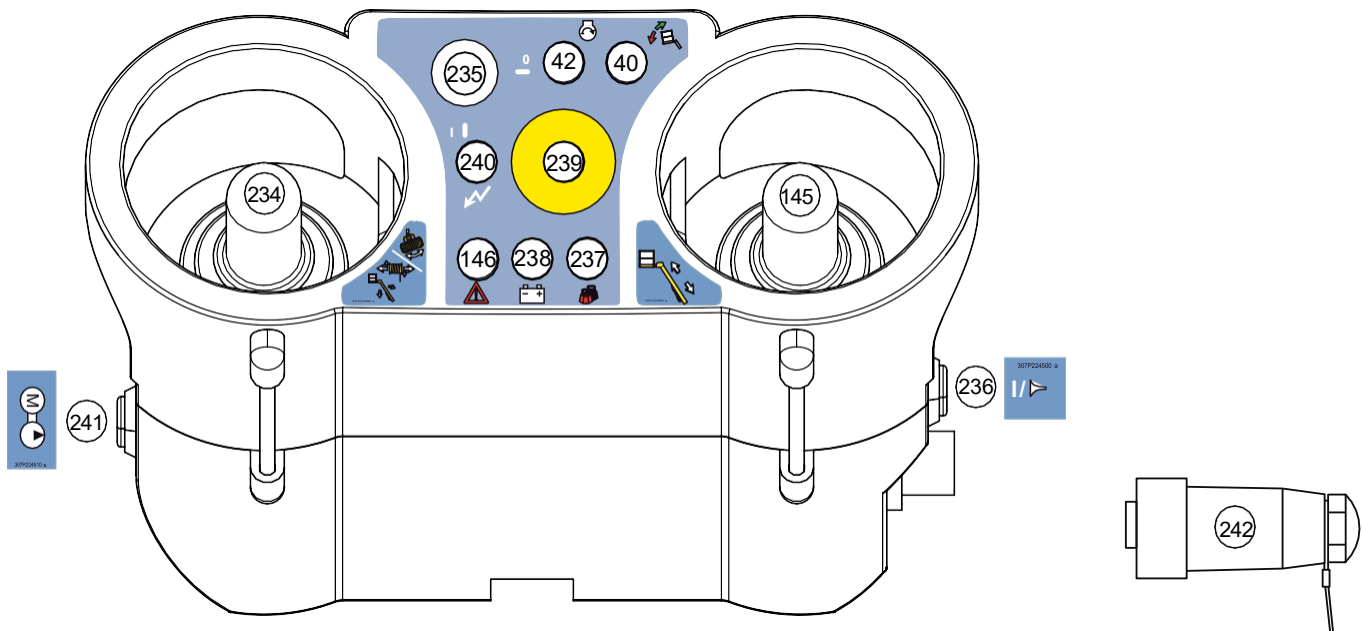

Radio-control emitter

Marking	Description	Function
P40	Accessory compensation control	Move upwards : Accessory lifting Move downwards : Accessory lowering
P42	Engine start-up selector	Starting the engine
P145	Telescoping joystick	Press the joystick to activate and confirm the movement <sup>(1)</sup> : Move forward : Boom in Press the joystick to activate and confirm the movement <sup>(1)</sup> : Move backward : Boom extend
P146	Fault indicator	Machine operating fault
P234	Boom lift joystick	Press the joystick to activate and confirm the movement <sup>(1)</sup> : Move upwards : Boom raising Press the joystick to activate and confirm the movement <sup>(1)</sup> : Move downwards : Boom descent
	Accessory orientation joystick	Press the joystick to activate and confirm the movement <sup>(1)</sup> : Move to the left : Clockwise rotation Press the joystick to activate and confirm the movement <sup>(1)</sup> : Move to the right : Counter clockwise (CCW) rotation
	Power switch	Position 0 : De-energizes control system Position 1 : Energizes control system
P236	Buzzer push button / Remote control validation <sup>(2)</sup>	Buzzer / Remote control validation
P237	Weighing indicator / Anti-tipping system	Permanently on in case of overload
P238	Battery charge indicator	Constantly on : Engine off or problem with the battery charging system Flashing : If the back-up pump is in use Pulled out (activated) : Remote control power supply
P239	Emergency stop button	Pushed down (deactivated) : Power cut to the platform controls and engine stopped
P240	Remote control on indicator	On : Remote control switched on
P241	Back-up pump unit push button	Pressed down (activated) : Back-up unit activated Release (deactivated) : Back-up unit deactivated

# C - Pre-operation and controls

Marking	Description	Function
P242	Electrical connector	Electrical connection of the remote control

(1) : Press the joystick to activate and confirm the movement. The operator can then operate the joystick without having to hold it down. Movement validation is cancelled if the joystick returns to neutral position for longer than 5 s.

(2) : The 2 joysticks (( P145 ) and ( P234 )) must be in neutral position in order to validate switching on of the remote control.

### 3.3.1 - Safety devices

To protect the user and the machine, safety systems prevent the operation of the machine beyond its capacities.

These security systems if activated, immobilize the machine and neutralize the movements.



**Poor knowledge of the characteristics and operation of the machine can lead the operator to think that a normal safety operation is a malfunction.**

#### 3.3.1.1 - Activation of controls

The controls must be validated by a 'Enable Switch' system to activate the different movements : Press on the joystick to activate and confirm the movement and then operate the joystick ( P145, P234 ).

#### Detection of internal fault

The defect indicator flashes to indicate an internal malfunction.

The machine switches to downgraded mode.

Certain movements can be limited or forbidden to preserve the operator's safety.

#### Overload

If the load on the accessory is greater than the maximum authorised load, no movement is possible using the remote control.

Movements which could worsen the situation are prevented :

- Arm lowering (unless the telescope is retracted).
- To telescope out.

The weighing indicator ( P237 ) flashes and an intermittent audible signal warns the user.

There are 2 options that will allow restoration of normal operation :

- Remove some weight to return within the authorised load.
- Use the console located in the cab to lower the platform.

**N.B.-:** -All movements from the console located in the cab are slowed down and movements which could worsen the situation are prevented.



# C - Pre-operation and controls



## Notes

# D - Operation

## 1 - Engine

**N.B.:** -The fuel to be used is regulated by national laws; refer to these requirements to define the appropriate fuel. Using unsuitable fuel may cause diminished performance, difficulties starting, excessive pollution and premature wear. To establish the type of fuel suitable for the engine fitted on your HAULOTTE® machine, please refer to the engine manufacturer's manual. The engine may not be covered by the warranty in case of damage caused by using unsuitable fuel.

### 1.1 - STARTING THE ENGINE

This machine can be operated at temperatures of -20 °C(0 °F) to 40 °C(104 °F) . Consult HAULOTTE Services® for operation outside this temperature range.

- Turn on the battery isolator located under the cab to the left of the steps.
- Make sure that all of the controls are in neutral and that all of the electrical components (lighting, heating, defrost system, ...) are turned off.
- Insert the ignition key.
- Turn the ignition key completely to position 1.
- Wait until the pre-heating light ( P188 ) goes off before starting the engine.

The following LEDs should light upon start-up and then go off again :

- Parking brake LED P182 (possible if deactivated for a prolonged period).
- Battery LED P180.
- Service brake fault LED P190 (possible if deactivated for a prolonged period).



**Do not actuate the starter for more than 15 s at the time.**

**Wait 10 s seconds between 2 attempts to avoid excessive drain of the battery power.**

**Do not try to start the machine by towing or pushing it, this could cause serious damage to the hydrostatic transmission.**



**If a LED indicates a fault, stop the engine immediately and perform the necessary operations or contact HAULOTTE Services®.**

- Warm up the engine at approximately 1/2 throttle.

**N.B.:** -The engine will not start if the gear control lever is not in neutral.



**Unexpected movement hazard. Always ensure that the gear control lever is in neutral.**



**Engine explosion. Do not spray ether into the air intake when starting the engine in cold weather. "Failure" to comply with these instructions could result in death or serious injury.**

# D - Operation

## 1.2 - OPERATIONAL CHECKS

### 1.2.1 - During the warm-up period

Check at the beginning of each work shift or at each change of operator :

- The heating, the defrost system and the windscreen wiper.
- check all lighting systems for proper operation.



**Keep the engine cover closed while the engine is running. "Failure" to comply with these instructions could result in death or serious injury.**

### 1.2.2 - When the engine is running

Check at the beginning of each work shift or at each change of operator :

- Service brake and parking brake operation.
- Forward and reverse.
- Each gear.
- Steer in 2 directions with the engine at idling speed. Check each steering mode (Forward and reverse).
- The horn and the back-up alarm. They must be audible from inside the operator's cab with the engine running.
- All of the boom and attachment functions should operate smoothly and correctly.
- Perform all additional checks (  Section H - Lubrication and maintenance).

## 1.3 - STARTING THE ENGINE WITH A BOOSTER BATTERY

If the engine has to be started with a booster battery (jumper cable...) proceed as follows :

- Never allow the vehicles to come into contact with each other.
- Connect the (+) terminal of the discharged battery to the (+) terminal of the booster battery.
- Connect the terminal - of the back-up battery to the terminal - of the discharged battery.
- Follow the standard starting procedures.
- Remove the cables in reverse order once the machine has been started.



**Never jump-start or charge a frozen battery as it could explode. Do not produce sparks or flames or smoke near the battery. Lead acid batteries generate explosive gases when charging. Wear safety glasses. "Failure" to comply with these instructions could result in death or serious injury.**



# D - Operation

## 1.4 - NORMAL ENGINE OPERATION

Observe the gauges and the display screen frequently to ensure that all engine systems are functioning properly.

Pay attention to unusual noises and vibrations. If a fault occurs, park the machine in a safe position and perform the shut-down procedure (  Section D 1.5 -Engine shut-down procedure). Report the fault to HAULOTTE Services®.

Avoid prolonged idling. Turn the engine off when not in use.

## 1.5 - ENGINE SHUT-DOWN PROCEDURE

Park the machine in a safe location on a flat surface and away from any other equipment or traffic lanes.

- Actuate the parking brake switch P214.
- Shift the speed selector to neutral.
- Lower the forks or the attachment to the ground.
- Operate the engine at idling speed for 15 s.



**Do not overrev the engine.**

- Stop the engine : Turn the ignition key to the left to position "0".
- Remove the ignition key.
- Exit the machine correctly.
- Block the wheels if necessary.
- Switch off the battery disconnecter located under the cab on the left of the steps.



**The cab seat is fitted with a device preventing the machine from moving if the operator is not sitting on the seat correctly.**

## 1.6 - PARKING BRAKE OPERATION

At speeds under 5 km/h (3,1 mph) , pressing the switch ( P214 ) automatically activates the parking brake.

When the parking brake is activated, the indicator lights ( P190 ) and ( P214 ) stay lit.

At speeds higher than 5 km/h (3,1 mph) , pressing and holding the switch ( P214 ) triggers an audible signal and the indicator light flashes ( P182 ).

After pressing the button for 2 s, the parking brake is automatically triggered.



**In this configuration, stopping the machine is detrimental.**

***N.B.-:Even if the machine's speed goes below 5 km/h (3,1 mph) during these 2 s, the parking brake is activated automatically.***

# D - Operation

## 2 - Operation with a load

### 2.1 - LOAD LIFTING SAFETY

- Know the weight and the centre of gravity of each load to be lifted.
- Use the load capacity chart associated with each attachment.



**Exceeding the machine's lifting capacity may damage the equipment and/or cause tipping over, resulting in death or serious injury.**

You should know the machine's rated load capacities to determine the operating range within which you can safely lift, transport and place loads (  Section G - Technical characteristics).

### 2.2 - BEFORE LIFTING A LOAD

- Check the ground conditions. Adapt the travel speed and reduce the load weight according to the ground.
- Avoid lifting unbalanced loads.
- Make sure that there are no obstacles near the load.

#### 2.2.1 - For operation with non-suspended load

- Adjust the fork spacing so that they engage into the pallet or under the load at maximum width and remain centred on the fork carriage.
- Face the load and approach it slowly with the fork tips straight and horizontal.

#### 2.2.2 - For operation with suspended load

- Only use approved lifting devices rated for the lifting of the load (  Section E - Attachments).
- Identify the proper lifting points of the load, taking into consideration the center of gravity and load stability.
- Always properly tether loads to restrict movement.



**Wheels must be aligned to lift a load.**



**Never lift any loads if a correct and legible capacity chart corresponding to the accessory used is not displayed in the operator's cab.**





**Never operate the telehandler without a proper and legible capacity chart displayed in the operator's cab for the telehandler/attachment combination in use..**



# D - Operation

## 2.3 - TRANSPORTING THE LOAD

### 2.3.1 - For operation with non-suspended load

Once the load is engaged on the forks and leaning against the fork carriage, tilt the load backwards to place it in the travel position. Travel as specified  Section A - Safety precautions,  Section E - Attachments.

### 2.3.2 - For operation with suspended load

Travel in accordance with safety rules specified  Section A - Safety precautions,  Section E - Attachments.

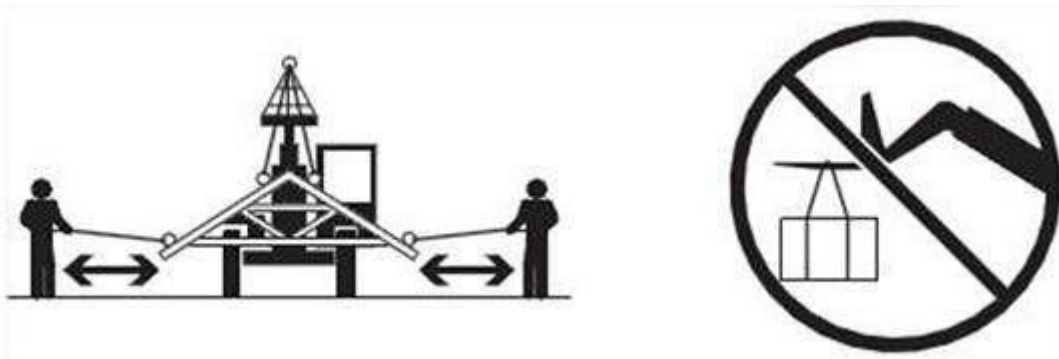

- Ensure the boom is fully retracted.



**Never raise the load more than 300 mm (11.8 in) above the ground or the boom more than 30°.**



**Never operate the machine controls suddenly.**

- The combination of sideways movement and the load could cause the machine to tip over.
- The guide persons must remain in constant communication (verbal or hand) and be in visual contact with the operator at all times.



**Never place the guide persons between the suspended load and the telehandler.**

- Only transport the load at walking speed (0.4 m/s) or less.

# D - Operation

## 2.4 - DUMPING PROCEDURE

- Position the machine in the best location for lifting or placing the load.
- Deactivate road mode and drive at a speed suited to the type of ground and the on-board load.
- Place the boom/attachment at less 30 °.
- Level the Telehandler cabin by operating the switch, check the level indicator to establish level status P200.



The purpose of the leveling function is to enable the machine to level out, so there is not additional tilt : Tip-over hazards.



Never raise the boom/attachment more than 1.2 m(3 ft11 in) above the ground unless the machine is leveled. The combination of sideways movement and the load could cause the machine to tip over.

The machine is designed to allow movement of the main chassis 10 ° forward and backwards.

## 2.5 - PLACING THE LOAD

Before placing a load :

- Ensure that the unloading point can safely support the weight of the load.
- Ensure that the unloading point is level, both lengthways and sideways.
- Use the capacity chart to determine the permitted boom extension range.
- Lower the forks to the level at which the load must be placed, and then extend the boom slowly until the load is just above the area where it must be placed.
- Lower the boom until the load rests in position and the forks can be retracted.

## 2.6 - DISENGAGING THE LOAD

Once the load has been safely placed at the unloading point, proceed as follows :

- When the load weight is no longer resting on the forks, the boom can be retracted and/or move the machine back from under the load if the surface so allows without changing the machine level.
- Lower the fork carriage.
- Drive the machine away from the landing point to continue work.

# D - Operation

## 3 - Road operation

- Preparation :
  - Remove any large amounts of dirt from the machine.
  - Check the lights and the mirrors, and adjust them if necessary.
- Follow the recommendation in force in the country of use (Registration plate, jacket, warning triangle, first-aid kit, chocks...).
- Lower the boom. The front edge of the attachment should be approximately 0,30 m(1 ft0 in) to 0,40 m(1 ft4 in) above the ground.
- Tilt the attachment back completely.
- Place a protective cover over the front edge of the bucket ; remove the carriage forks.
- Raise the stabilisers.
- If the rear wheels are not in line with the chassis, move them back slowly to a neutral position.
- Actuate the road switch P215.
- Empty the bucket (If equipped).



**Never carry loads on the road.**

- The machine is now ready for road operation.

***N.B.** :-Ensure that you follow all local, regional and national traffic regulations.*

A

B

C

D

E

F

G

H

I

# D - Operation

## 4 - Loading and securing for transport

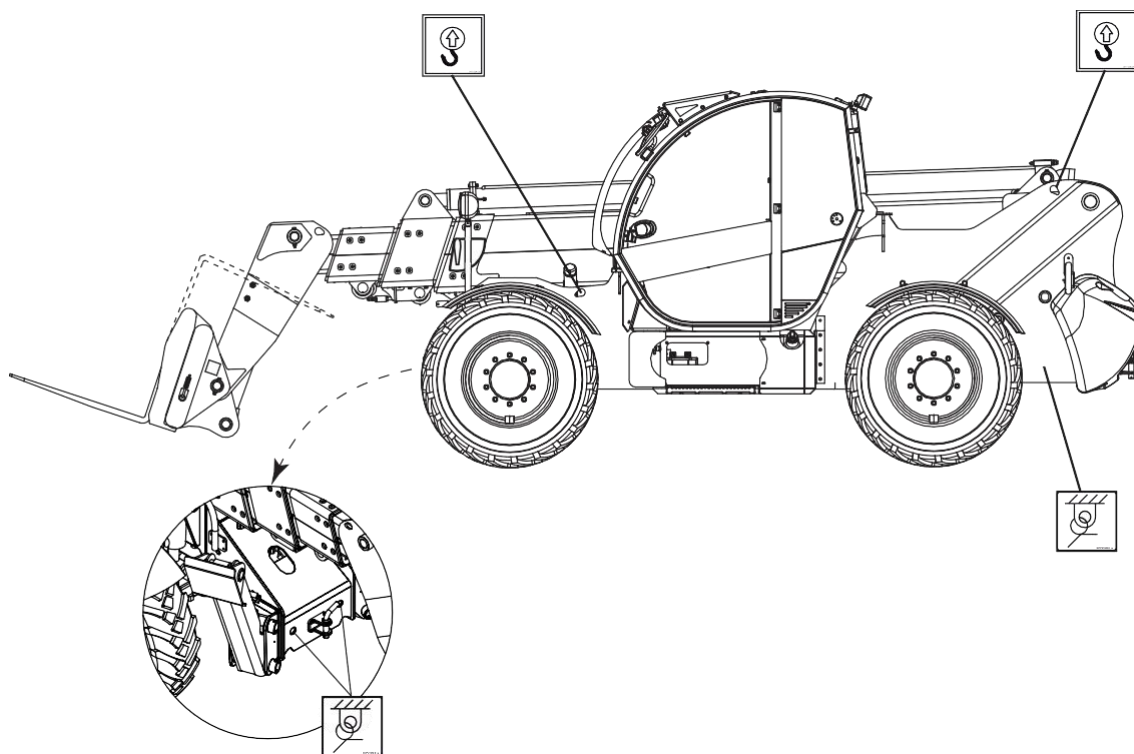

- Level the machine before loading.
- Obtain assistance from an operator for manœuvres and loading the machine, with the boom as low as possible.
- Once loaded, apply the parking brake and lower the boom until the boom or attachment touches the deck. Switch all controls to neutral, stop the engine and remove the ignition key.
- To secure the machine to the deck, pass chains through the designated tie-downpoints as illustrated in the figure.
- Do not tie down the front of the boom.

***N.B.-***The user is fully responsible for choosing the proper method of transportation and the tie-down devices : Ensure that the equipment used is able to support the weight of the vehicle to be transported and that all manufacturer's instructions and warnings, regulations and safety rules and all national, regional and local laws are followed.



**Before loading the machine to be transported, check that the deck, the ramps and the machine wheels are free of mud, snow and ice. Otherwise, the machine may slide, which could result in serious injury or death.**

# D - Operation

## Lifting the machine

Ensure that :

- The machine is completely folded
- The accessories are in good conditions and have sufficient capacity
- The staff performing the maneuvers is authorized and empowered to use lifting equipment

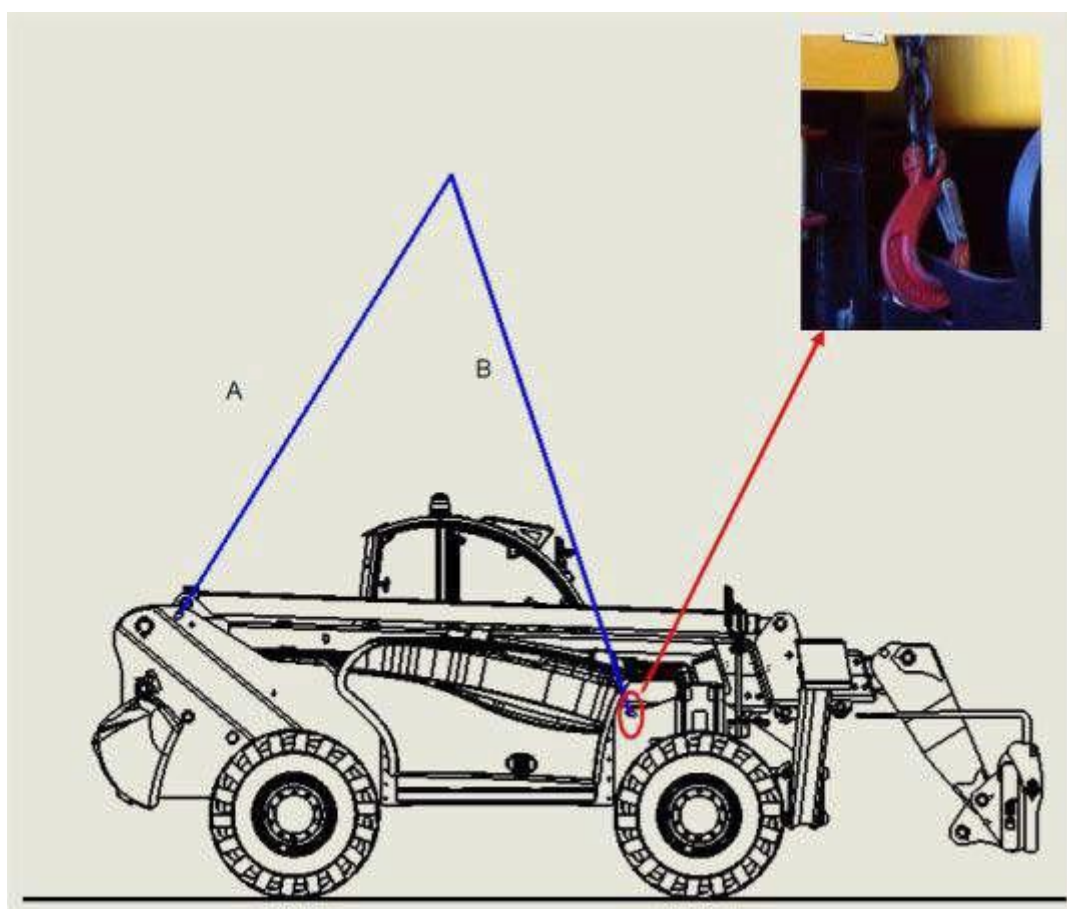

A	2 lifting straps length 3700 +/- 50 mm For HTL 3614 :
	2 lifting straps length 3780 +/- 50 mm For HTL 3617 :
B	2 lifting straps length 3900 +/- 50 mm For HTL 4014 / 4017 :
	2 lifting straps length 3780 +/- 50 mm



- Keep different length between A and B.
- Caution to lifting machine with air conditioned cab.

# D - Operation



Notes

# E - Attachments

## 1 - Approved attachments

To determine whether an attachment is approved for use on the machine in use, proceed as follows before installation of attachment :

- The attachment model/option number indicated on the attachment identification plate must correspond to the attachment number indicated on a capacity chart located in the operator's cab (For the forks, buckets and side-shift fork carriage). For other attachments, refer to the load chart booklet of the attachment.
- The model indicated on the capacity chart must correspond to the model of the machine being used.
- The center of gravity of the load on the fork (if applicable) must correspond to the center of gravity of the load indicated on the capacity chart.
- Hydraulically-powered attachments must only be used on machines equipped with auxiliary hydraulics.



If any of the above conditions are not met, do not use the attachment. The machine may not be equipped with the relevant capacity chart or the attachment may not be approved for the machine model being used. Additional information can be obtained from HAULOTTE Services®.



The user must enlist the services of a competent person to familiarise themselves with the test procedures for the specific attachments they have for the Telehandler. The user is responsible for carrying out any required checks of the attachment..



The user must ensure that the accessory can be used in the country in which the machine is be used.

## 2 - Unapproved attachments



Do not use attachments that have not been approved in writing by Haulotte for the following reasons :

- HAULOTTE® cannot establish the capacity range limits for DIY, home-made, altered or other unapproved attachments.
- An overextended or overloaded machine may tip over with little or no warning, can cause serious injury or death to the operator and/or those working nearby.
- HAULOTTE® cannot guarantee the ability of an unapproved attachment to perform its intended function safely.



Only use HAULOTTE approved attachments. Attachments that have not been approved by HAULOTTE for use with this machine may cause material and/or bodily damage, or even death.

# E - Attachments

## 3 - Telehandler/Attachment/Fork capacities

Before installing the attachment, check that it is approved and that you are in possession of the relevant capacity chart.

### Attachment manufacturer's plate

Part number	
Accessory type	
Serial number	
Manufacture date	
Authorized equipment	
Weight	Kg lbs
Maximum Capacity	Kg lbs

HAULOTTE GROUP  
La Piscine BP3  
42152 L'HOORME  
FRANCE

OU / OR

Part number	
Accessory type	
Serial number	
Manufacture date	
Weight	Kg lbs
Volume (SAE)	L
Capacity	Kg lbs
Wind speed max	m/s

### Load capacity chart

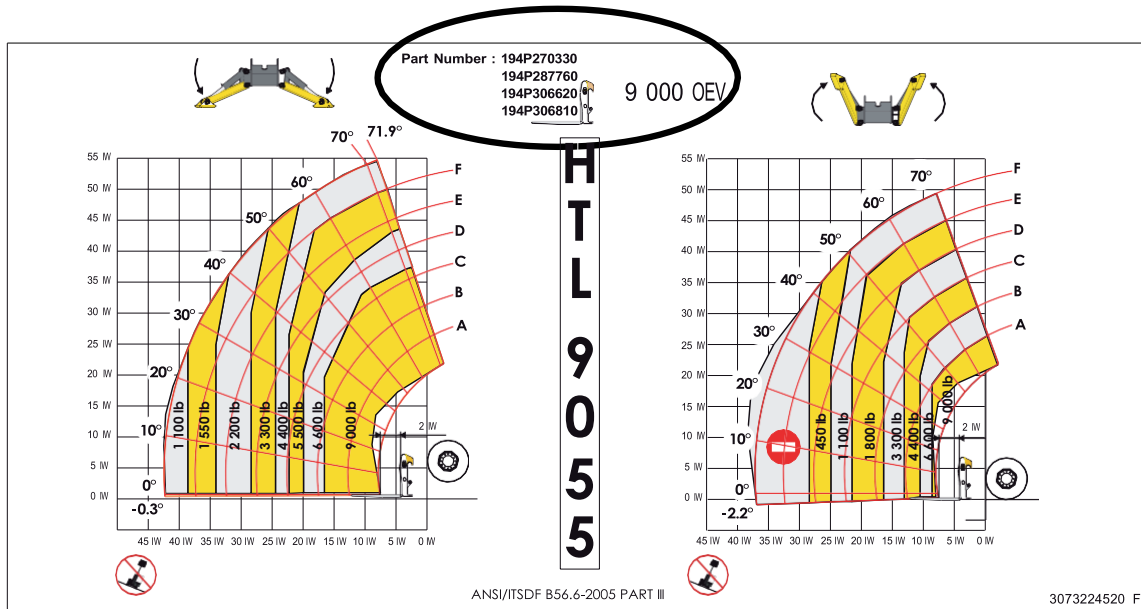

# E - Attachments

Load capacity chart

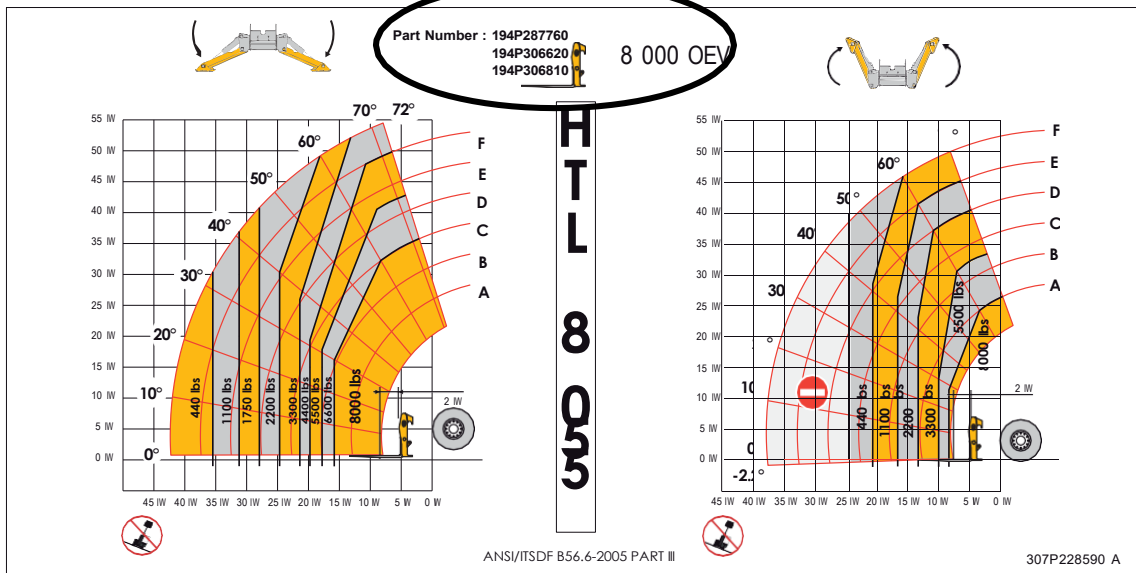

**N.B.:-** The attachment number located on the manufacturer's plate must correspond to the attachment number which appears on the load chart.

To determine the maximum capacity of the telehandler and the attachment, use the smallest of the capacities as determined by the capacity stamped on the attachment or the lifting position on the load chart..

The forks must be used in matched pairs.



**Never use an accessory without having checked the HAULOTTE® accessory load capacity chart installed on the telehandler. Failure to install the relevant HAULOTTE® supplied capacity chart could cause an accident resulting in death or serious injury.**

# E - Attachments

## 4 - Using the capacity chart with forks

To use the capacity chart properly, the operator must first determine and/or obtain the following :

- Approved attachments HAULOTTE®.
- A load chart corresponding to the attachment.
- The weight of the load to be lifted.
- The load placement data :
  - The height at which the load must be placed.
  - The distance the load must be placed forward of the front tires of the Telehandler.
- An alphabetical key ( A, B, C, D, E, F ) indicates the boom extension and a pendulum indicates the boom angle (  Section E - Boom angle indicator).
- On the capacity chart for a given load, find the area corresponding to the key and follow it to the permitted reach.
- The number that appears in the load capacity range must be equal to or greater than the weight of the load to be lifted. Determine the load capacity range limits with the capacity chart and keep within those limits.

### Boom angle indicator

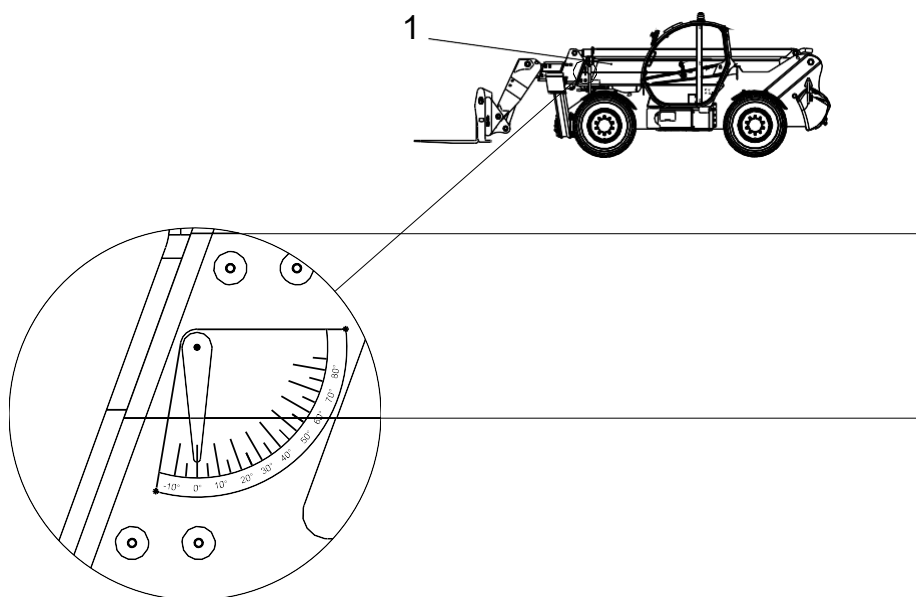

1 : Horizontal boom

# E - Attachments

Boom extension indicators

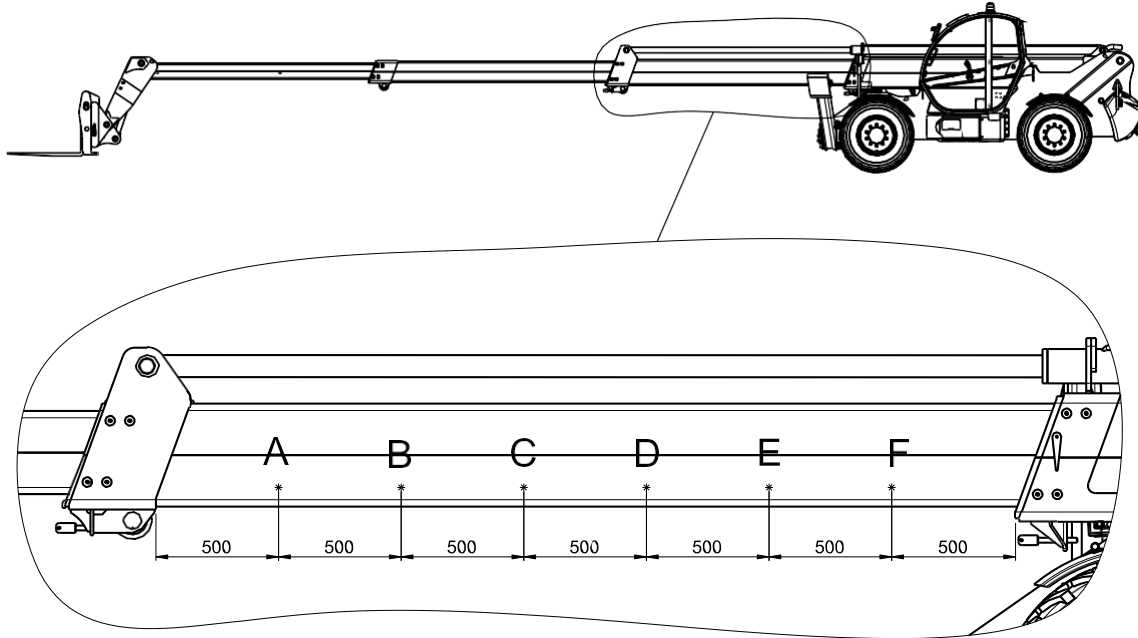

A

B

C

D

E

F

G

H

I

# E - Attachments

Example of a load capacity chart : HTL 9055

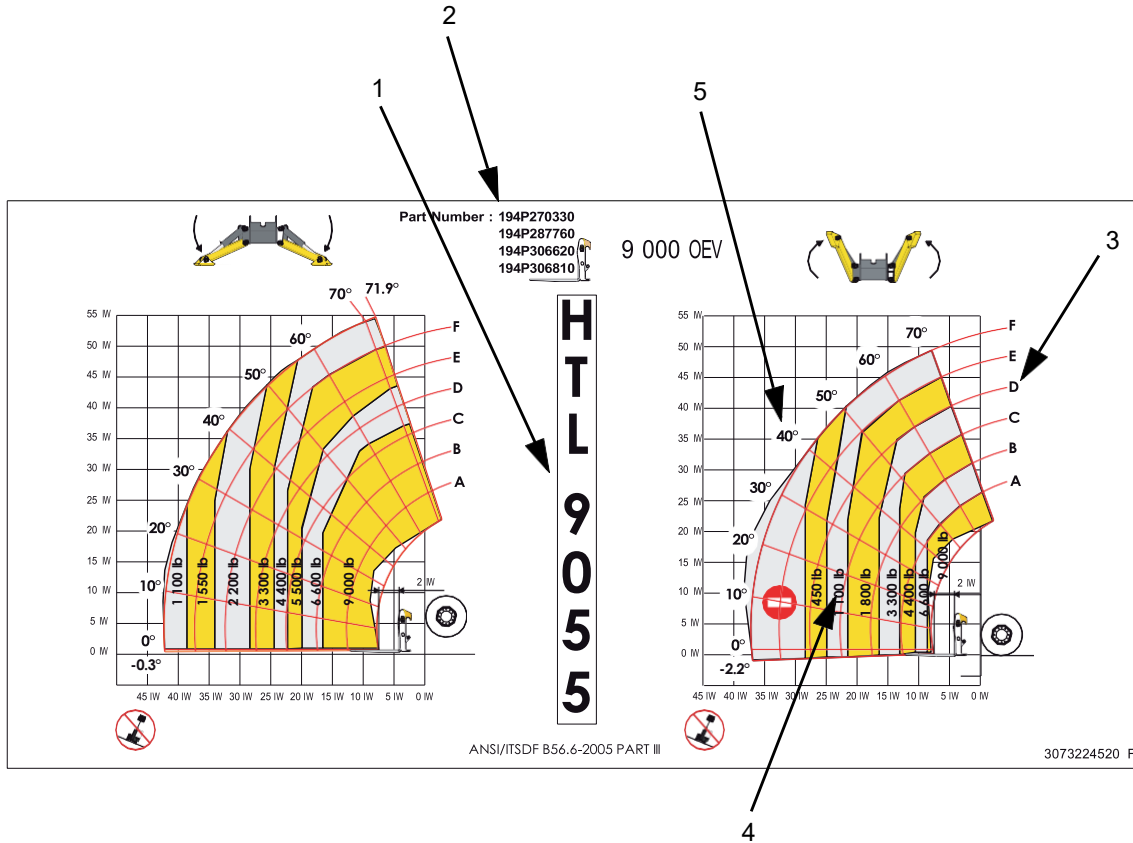

Marking	Description
1	HTL 4017 (HTL 9055) : The load capacity chart must only be used for this machine
2	Attachment reference : The attachment reference must correspond to the number on the attachment manufacturer's plate
3	Boom extension indicators
4	Load area : The load areas indicate the maximum weight which can be lifted
5	Boom angle

To identify the appropriate load capacity table, refer to the icons (representing the attachments) which appear on the table :

- To be used when lifting a load with the stabilisers raised :

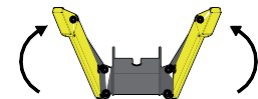

- To be used when lifting a load with the stabilisers lowered :

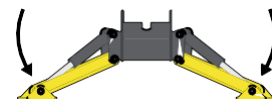

All of the loads indicated on the load capacity chart are based on the machine being on firm ground with the chassis level, the forks being positioned symmetrically on the fork carriage, the load being centred on the forks, appropriately sized tires being inflated correctly and the telehandler being in good working condition. "Failure" to comply with these instructions could result in death or serious injury.

# E - Attachments

Examples of how to read the load capacity chart for the HTL 4014 (HTL 9045) fitted with the fork carriage

The following examples illustrate situations where the load may or may not be lifted.



Use the capacity chart corresponding to the machine.



The attachment number located on the manufacturer's plate must correspond to the attachment number which appears on the load chart.

### Stabilisers lowered

Example	The weight of the load to be lifted	Distance	Height	Lifting authorised
1	2000 kg(4409 lb)	6 m(19 ft8 in)	10 m(32 ft80 in)	Yes
2	5000 kg(11023 lb)	7 m(22 ft96 in)	8 m(26 ft24 in)	No
3	4000 kg(8818 lb)	3 m(9 ft84 in)	5 m(16 ft40 in)	Yes

### Stabilisers raised

Example	The weight of the load to be lifted	Distance	Height	Lifting authorised
4	1000 kg(2204 lb)	3 m(9 ft84 in)	9 m(29 ft52 in)	Yes
5	1000 kg(2204 lb)	6 m(19 ft88 in)	6 m(19 ft68 in)	No
6	500 kg(1102 lb)	8,5 m(27 ft88 in)	4 m(13 ft12 in)	No

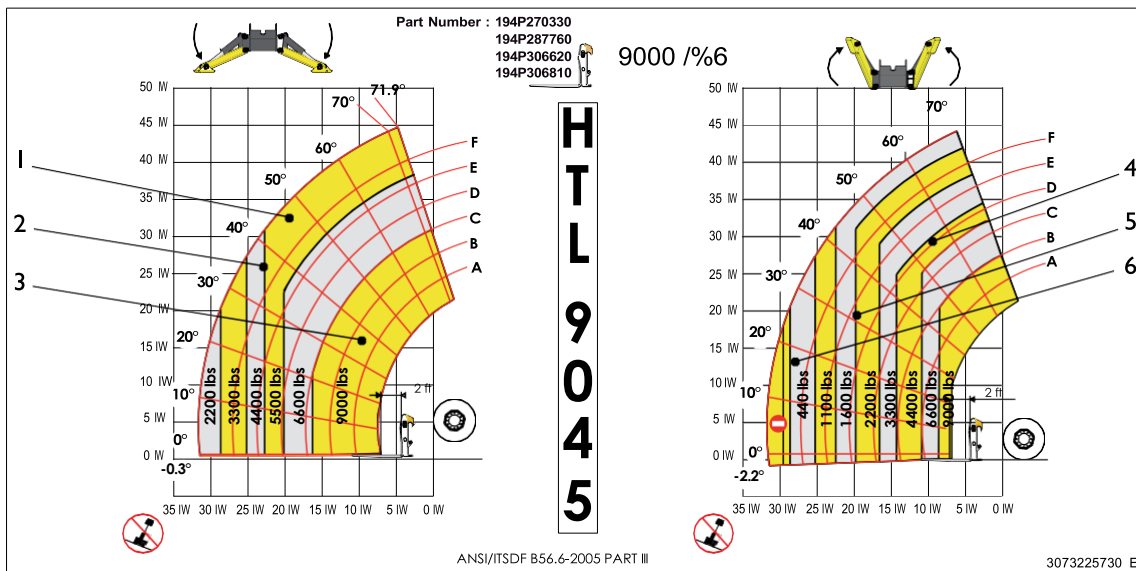

# E - Attachments

HTL 9055 load capacity chart

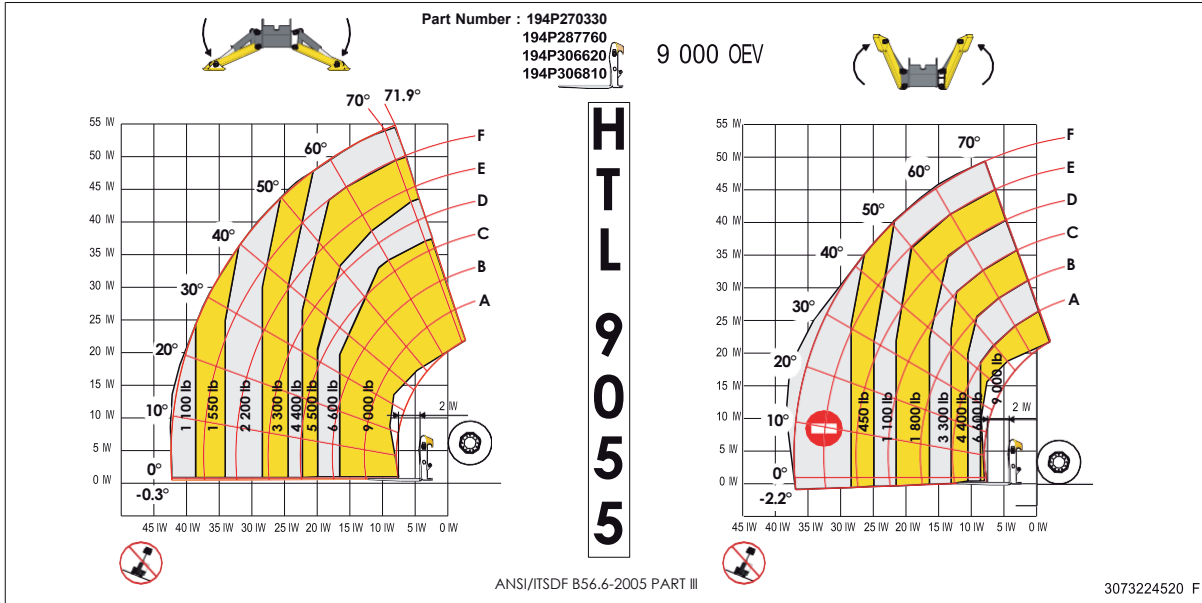

HTL 9045 load capacity chart

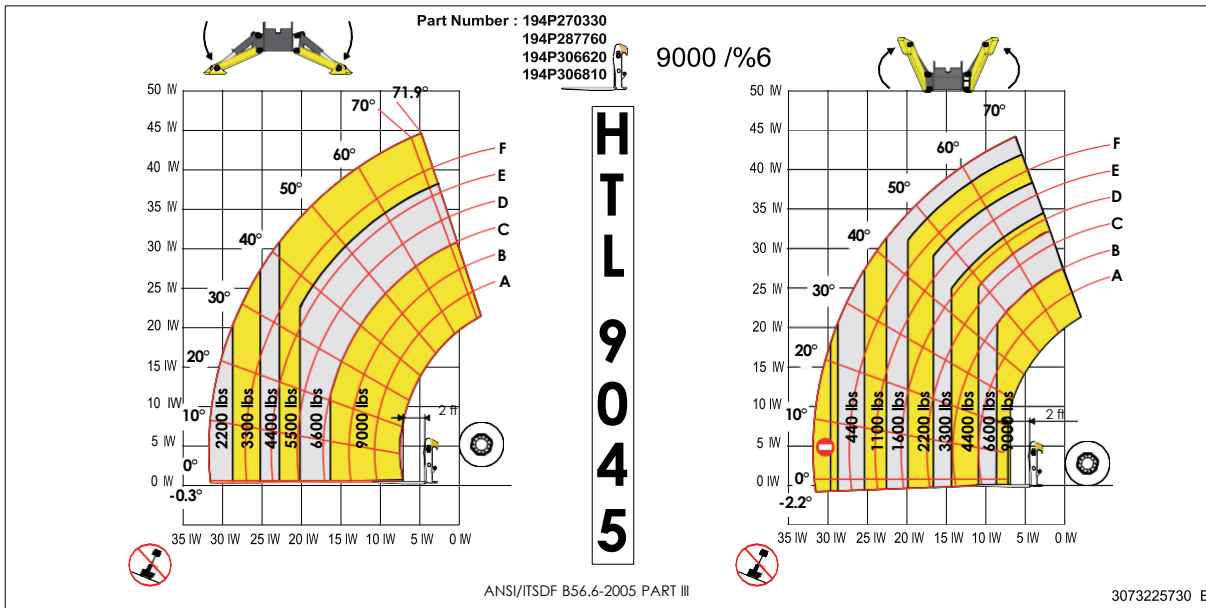

# E - Attachments

HTL 8055 load capacity chart

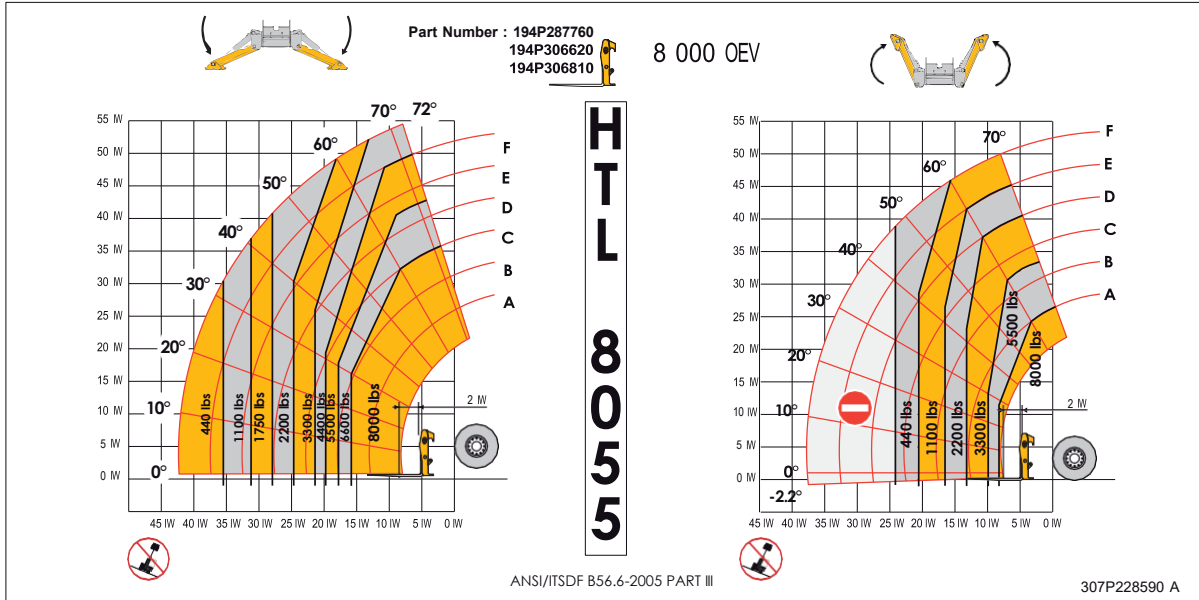

HTL 8045 load capacity chart

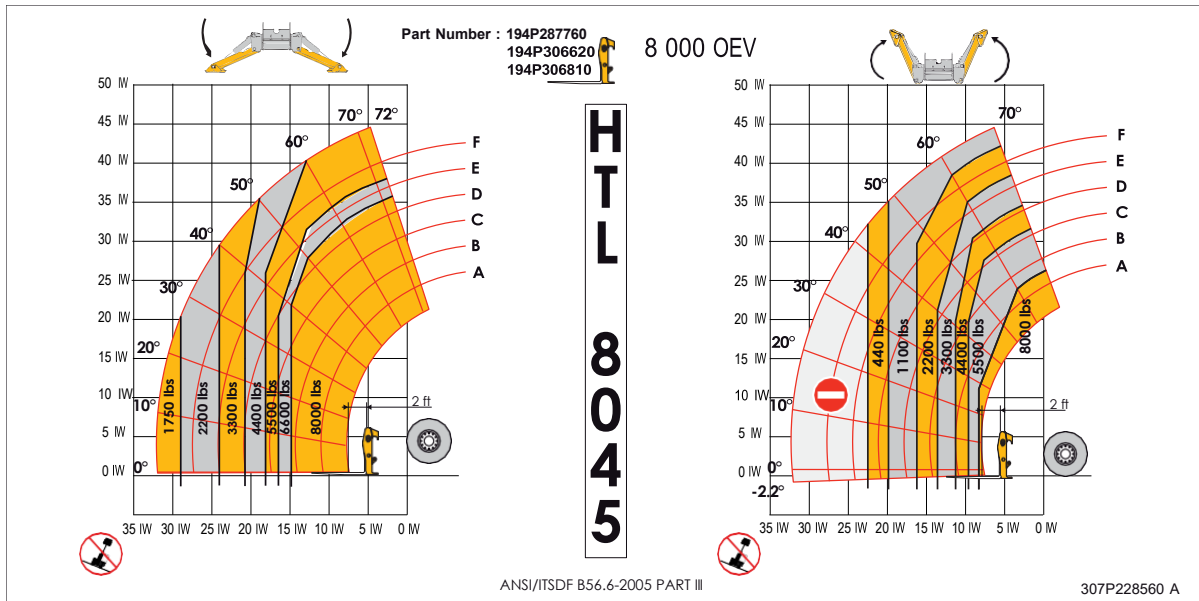

Forks characteristics

Length	Width	Weight
1200 mm	125 mm	80 kg
1200 mm	100 mm	65 kg

# E - Attachments

## 5 - Attachment installation

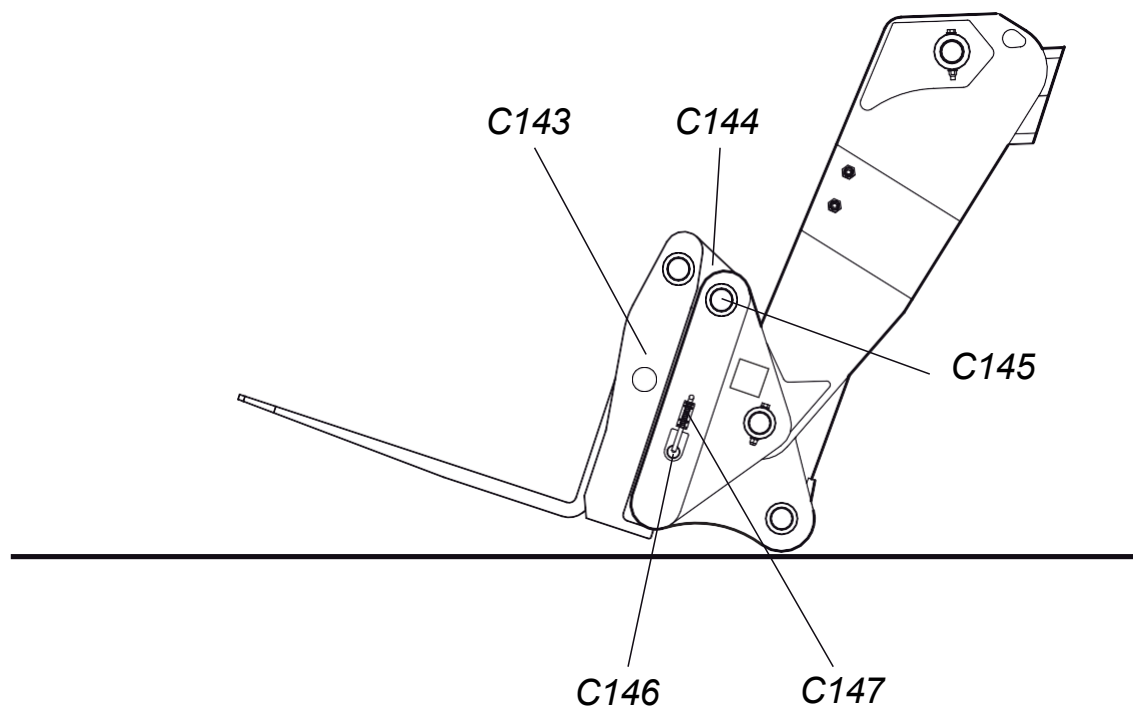

Description of the components

Marking	Description
C143	Attachment
C144	Attachment pin recess
C145	Attachment pin
C146	Lock pin
C147	Retainer pin



Always ensure that the fork carriage or the accessory is correctly positioned on the boom, secured by 2 locking pins and held in place by 2 retaining locks. Incorrect installation could result in the fork carriage/attachment/load disengaging, causing death or serious injury.

### 5.1 - MECHANICAL ATTACHMENT LOCKING DEVICE

- Pull the locks and disengage the locking pins from the accessory.
- Align the tool apron pin with the attachment recess by lifting and crowding ( P211 ).
- Actuate the parking brake P214. Leave the cab, insert the locking pins and secure them with the retaining locks.
- If the attachment requires hydraulic control, connect auxiliary hydraulic hoses A and B.

# E - Attachments

## 5.2 - HYDRAULIC ACCESSORY LOCKING DEVICE (OPTION)

### 5.2.1 - Specific instructions



Before installing the hydraulic adaptation kit, ensure :

- that the boom is below 15 °.



The hydraulic adaptation kit connection is carried out with the machine stopped.

### 5.2.2 - Operation

- Connect the hoses from the hydraulic adaptation kit to the push/pull sockets on the tool holder carriage.



- Start the engine.
- Align the tool apron pin with the attachment recess by lifting and crowding ( P211 ).
- To unlock the tool holder carriage, press the locking button for at least 2 s and hold down.

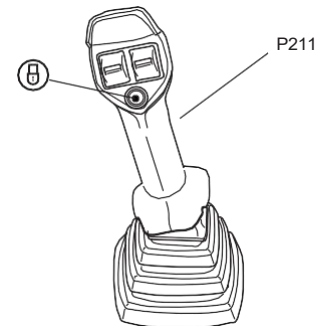

- Carry out the attachment installation operations while holding the locking button down.
- Release the button to lock.



Releasing the button locks the attachment.



Do not press on the locking button for longer than 2 s when the auxiliary line is connected to the attachment. Danger of unexpected movement.



If the attachment requires hydraulic control, connect auxiliary hydraulic hoses A and B.



Hold the button down for 5 s to unlock the carriage.

# E - Attachments

## 5.3 - ADJUSTING/MOVING FORKS

Fork carriages may have different locations for positioning forks.

**N.B.:-**Apply a light coating of an appropriate lubricant to facilitate fork or fork bar sliding.

To slide the forks :

- Ensure that the fork carriage is correctly installed :  Section E - Attachments.
- Lift the boom by approximately 10 °, tilt the fork carriage forwards until the fork heel is no longer in contact with the fork carriage.
- Stand next to the fork carriage to slide the fork, push it or pull it near its pin.

If the forks must be changed out :

- Place the forks on the ground.
- Remove the fork pin.
- Change out the forks and place them in position.
- Change out the fork pins and their retaining mechanisms.

Using forks :

- The machine's capacity and range limits change according to the forks used.



**Keep the specific instructions for the forks in the manual holder situated behind the cab seat, with the telehandler operator manual.**

# E - Attachments

## 6 - Attachments



Familiarize yourself with the information provided on the attachment identification plate.



Use the capacity table (load chart booklet) corresponding to this accessory.



Keep the specific instructions for the forks in the manual holder situated behind the cab seat, with the telehandler operator manual.

### 6.1 - TECHNICAL CHARACTERISTICS OF THE ACCESSORIES

Floating forks carriage		
Attachment reference	194P287760 194P306620	
Mass	290 kg(639 lb)	
Dimensions of pallet forks	Section (Standard)	0,125 m (41 in) X 0,050 m (2 in)
	Section (Option)	0,100 m (40 in) X 0,050 m (2 in)
	Length	1,2 m(4 ft0 in)
Nominal capacity	4000 kg(8819,49 lb)	
	 If the capacity of the machine is less than 4000 kg(8819,49 lb), respect the nominal capacity of the machine	



Carriage extension (Option)	
Attachment reference	194P306780
Length	1,15 m(3 ft9 in)
Height	0,473 m(1 ft7 in)
Mass	20 kg(44 lb)

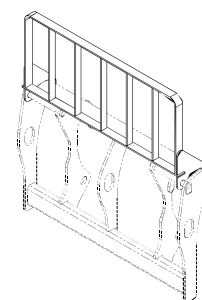

# E - Attachments

Side-shift fork carriage Hydraulic kit		
Attachment reference	2820303940	
Width	1,25 m(4 ft10 in)	
Mass	390 kg(860 lb)	
Dimensions of pallet forks	Section	0,125 m (41 in) X 0,045 m (1,7 in)
	Length	1,2 m(4 ft0 in)
Lateral movement	100 mm in relation to the central position	
Nominal capacity	3000 kg(6614 lb)	
User pressure	180 bar	(2610,67 psi)
Maximum admissible pressure	220 bar	(3190,83 psi)
Minimum flow	50 l/min	
Standard : FEM3A		

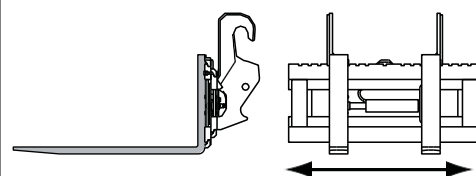

# E - Attachments

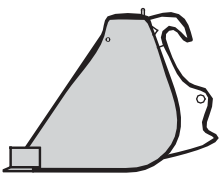
Toothless bucket		
Attachment reference	2820302810 4000423980	
Nominal capacity	1140 l (301 gal)	
Width	2,4 m (7 ft 10 in)	
Mass	465 kg (1025 lb)	

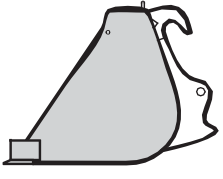
Toothed bucket		
Attachment reference	2820302820	
Nominal capacity	1140 l (301 gal)	
Width	2,4 m (7 ft 10 in)	
Mass	595 kg (1312 lb)	

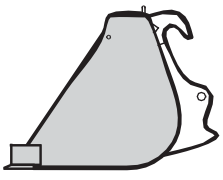
4-in-1 bucket Hydraulic kit		
Attachment reference	2820302830	
Nominal capacity	850 l (225 gal)	
Width	2,4 m (7 ft 10 in)	
Mass	636 kg (1402 lb)	

A

B

C

D

E

F

G

H

I

# E - Attachments

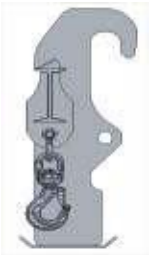
<b>4 T (8820 lb) 0 m(0 ft0 in) jib crane</b>		
Attachment reference	4000023260	
Nominal capacity	4000 kg(8820 lb)	
Mass	72 kg(159 lb)	

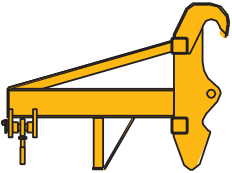
<b>3 T (6615 lb) 1 m(3 ft3 in) jib crane</b>		
Attachment reference	2820305490	
Nominal capacity	3000 kg(6615 lb)	
Mass	141 kg(311 lb)	

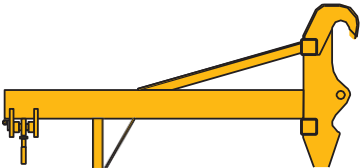
<b>2 T (4410 lb) 2 m(6 ft7 in) jib crane</b>		
Attachment reference	4000016740	
Nominal capacity	2000 kg(4410 lb)	
Mass	205 kg(452 lb)	

# E - Attachments

A

B

C

D

E

F

G

H

I

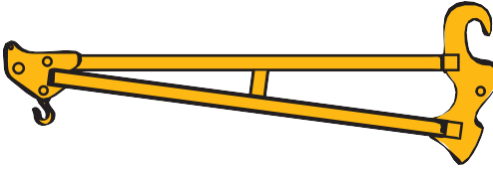
<b>Fly jib 2,5 m(8 ft2 in), 1,2 T (2646 lb) on telescopic arm</b>		
Attachment reference	2820304080	
Nominal capacity	1200 kg(2646 lb)	
Mass	206 kg(454 lb)	

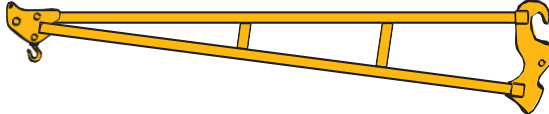
<b>Fly jib 4 m(13 ft1 in), 0,6 T (1323 lb) on telescopic arm</b>			
Attachment reference	2820304090	2820304090	
Nominal capacity	600 kg(1323 lb)		
Mass	276 kg(609 lb)		

<b>Fly jib 2,5 m(8 ft2 in), 1,2 T (2646 lb) with hydraulic winch</b>		
Attachment reference	2820304120	
Nominal capacity	1200 kg(2646 lb)	
Mass	310 kg(684 lb)	

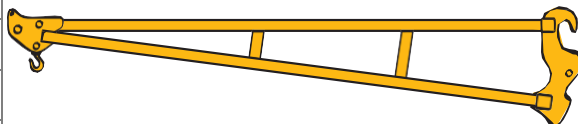
<b>Fly jib 4 m(13 ft1 in), 0,6 T (1323 lb) with hydraulic winch</b>		
Attachment reference	2820304130	
Nominal capacity	600 kg(1323 lb)	
Mass	375 kg(827 lb)	

# E - Attachments

<b>Winch 1,2 T (2646 lb) Hydraulic kit</b>		
Attachment reference	2820304100	
Nominal capacity	1200 kg(2646 lb)	
Mass	190 kg(419 lb)	

<b>Winch 2,4 T (5292 lb) Hydraulic winch</b>		
Attachment reference	2820304110	
Nominal capacity	2400 kg(5292 lb)	
Mass	190 kg(419 lb)	

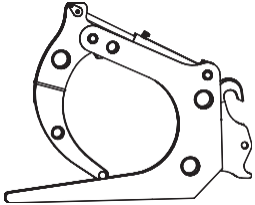
<b>Fork grapple</b>		
Attachment reference	4000475900	
Nominal capacity	3000 kg(6614 lb)	
Mass	930 kg(2050 lb)	

# E - Attachments

## 6.2 - OPERATION

### 6.2.1 - Accessory control

The joystick ( P211 ) controls movements of the boom and attachment tilt (  Section C 2.5.8 - Joystick).

### 6.2.2 - Attachment installation procedure

 Section E 5 - Attachment installation.



Incorrect installation could result in the attachment or load disengaging, causing death or serious injury.

### 6.2.3 - Using the load capacity chart



Make yourself familiar with the information  Section E 3,  Section E 4.



Use the capacity table (load chart booklet) corresponding to this accessory.



The machine must not be used without the capacity chart booklet.



All the loads indicated on the nominal capacity chart (load chart booklet) assume that the machine is on firm ground with the chassis level, the load evenly distributed on the attachments, tyres of the correct size, sufficiently inflated and that the handler is in good working order. "Failure" to comply with these instructions could result in death or serious injury.

### 6.2.4 - Operation

- Raise or lower the boom to the appropriate height for lifting the load.
- Lift the load smoothly and with the boom fully retracted.
- Travel as specified  Section A - Safety precautions.

# E - Attachments



## Notes

# F

## - Emergency procedure

### 1 - Towing a broken-down vehicle

#### 1.1 - GENERAL PRECAUTIONS



Towing must only be performed when the Telehandler has broken down and once the operator has ensured that there is no risk of additional damage.

The first option should be to complete repairs on-site.

If the Telehandler is on a public highway, ensure that no part of the Telehandler encroaches onto the road. If encroachment cannot be avoided, place warning signage on the road in accordance with the currently applicable regulations (example: warning triangle (optional), safety vest for the operator (optional), etc.).

Before towing the Telehandler, complete the following :

- Check that the steering can be used.
- Unbraked the front axle according to the procedure (  Section F 1.2 - Releasing the axle brake for towing. ).
- To tow the telehandler, attach a tow-bar to the towing clevis situated at the rear of the telehandler.

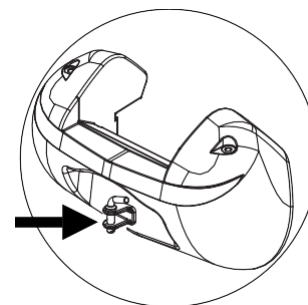

If the Telehandler must be towed, the combined weight of the towing vehicle and machine must not exceed to 28,5 Tonne.



Towing is performed at the operator's risk and must be completed with extra care.

- Ensure that the Telehandler boom is sufficiently raised to avoid interferences with the ground or the towing vehicle.
- If the Telehandler boom cannot be raised sufficiently to avoid interferences, contact HAULOTTE Services®.

Before towing the Telehandler, you should loosen the two pressure limiters on the travel pump by three turns 1.

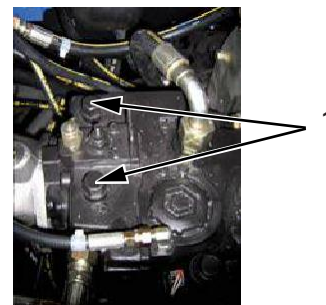

(1) Unscrew each pressure relief valve by 3 turns before towing.

The maximum travel speed permitted for towing is 6 km/h (4 mph) . The towing distance should not exceed 300 m(984 ft4 in).

- Turn on ignition key and start up engine..
- Deactivate the parking brake.
- When the parking brake is released, the machine can be towed.

# F

## - Emergency procedure

If the parking brake is still engaged and the engine has broken down, de-activate the brake before towing (  Section F 1.2 - Releasing the axle brake for towing. )

### 1.2 - RELEASING THE AXLE BRAKE FOR TOWING

The following procedure is used to release the front axle parking brake in the event of a engine breakdown or when the accumulator is empty.

#### 1.2.1 - Parking brake deactivation

Tools required :

- Spanner 19 mm.



**Block the four wheels with chocks to prevent any machine movement when the brake is disengaged.**

- Loosen the lock nuts.
- Fully tighten the 4 screws.

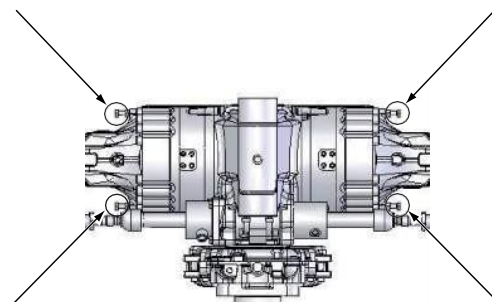

**Come out from under the Telehandler and remove the chocks placed under the four wheels.**

- Park the Telehandler.
- Block the four wheels again.
- The machine can be towed (  Section F 1.1 - Towing a broken-down vehicle).

#### 1.2.2 - Parking brake reactivation

Tools required :

- Spanner 19.



**Block the four wheels with chocks to prevent any Telehandler movement when the brake is disengaged.**

When the four wheels are properly blocked :

- Loosen the 4 screws from 18 mm to 21 mm.
- Tighten the lock nuts.

The parking brake can then be reactivated and the front wheels blocked.

- Remove the chocks from the four wheels.
- Check that the hand brake control functions properly.

# F

## - Emergency procedure

### 2 - Emergency boom lowering

#### 2.1 - MANUAL BOOM LOWERING (EMERGENCY MODE)



This operation should only be performed as a last resort as it presents a danger for the operator (machine and load stability).

Before any manual lowering operation :

- Retract the boom before lowering it.
- Activate the parking brake and chock the wheels.

If the boom cannot be retracted, check on the load capacity chart in the cab that lowering the boom in a horizontal position is compatible with telehandler stability.

- Block the boom in position with another another machine, a crane or, as a last resort, the cylinder chock.
- Completely unscrew the stop screw from the counter-balance valve block flanged on the boom lift cylinder. Remove the locknut and rescrew the stop screw fully into its socket ( 1 ).

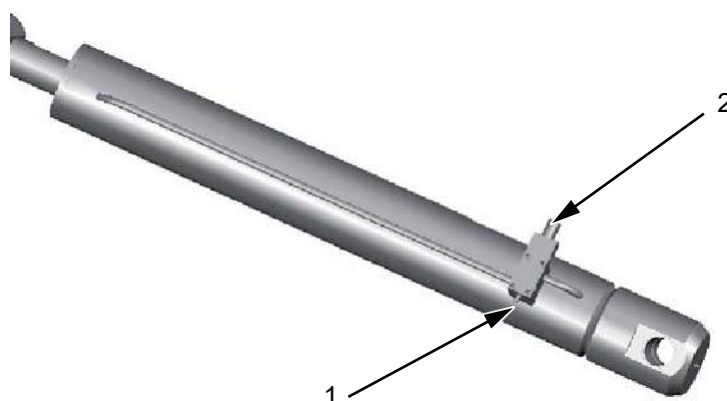

Marking	Description
1	Stop screw
2	Counter-balance valve flange-mounted on the cylinder

- Take off the cover located under the counterweight at the rear of the machine to access the valve block.

# F

## - Emergency procedure

- Slowly unscrew the cap ( 3 ) situated on the boom lift plate (first valve from the left) until you can see the boom lowering, then screw up once the boom in low position.

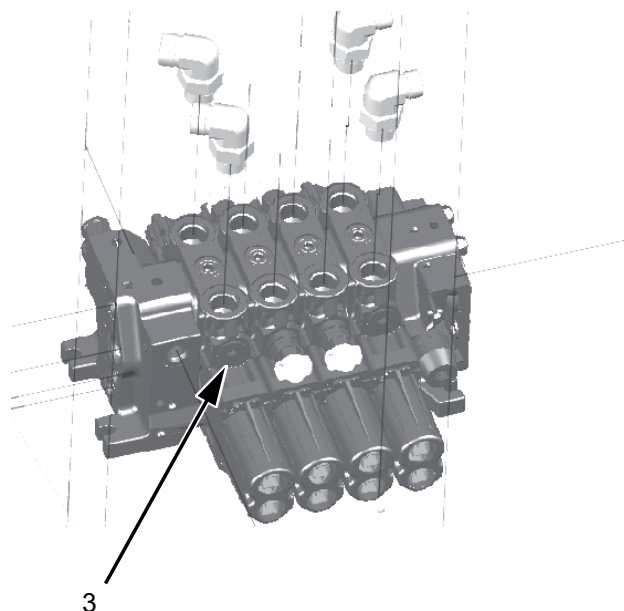

- Once the boom is lowered and the machine has been repaired, raise the boom to its high position and secure it into place using the cylinder prop.
- Unscrew the stop screw from the counter-balance valve block, replace the counternut and rescrew the assembly fully into its socket.
- Check that the counter-balance valve functions properly after the intervention (by raising/lowering the boom with a load).



Secure the boom into position before any interventions on the counter-balance valve.

### 3 - Emergency exit from cab

In an emergency, exit from the cab can be achieved via the rear window..

- Release the stop ( 1 ) upwards.
- Push the window ( 2 ) outwards with your hand.

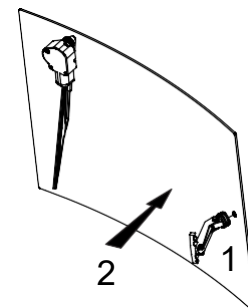

In accordance with the local and governmental regulations in force in some countries, a "break glass hammer" is provided inside the cab to allow exist in an emergency by breaking the rear window glass.

# G - Technical characteristics

## 1 - Main characteristics



Certain options can modify the machine's operating characteristics and its associated safety. If your Telehandler was originally delivered with options fitted, replacing a safety component associated with a particular option does not require any particular precautions other than those associated with the installation itself (static test). Certain options can modify the Telehandler's operating characteristics and its associated safety.

Otherwise, it is essential to follow the manufacturer's recommendations below :

- Any options added must be either HAULOTTE® original options, or must be approved in writing by HAULOTTE®.
- Installation by authorised HAULOTTE® personnel only.
- Update the manufacturer's identification plate.
- Have stability tests carried out by a certified agency/competent person.
- Ensure label compliance.

HAULOTTE® has a continuous improvement policy in place for its product range ; Given this policy, The Company reserves the right to modify their product technical characteristics without notice.

### 1.1 - TECHNICAL CHARACTERISTICS

Engine			
Model	Perkins 1104D44T	Perkins 854E-34TA (Wall Flow DPF)	Kohler KDI 3404 TCR
Type	Four-stroke, water-cooled		
Cubic capacity	4400 cm <sup>3</sup> (268,50 cu in)	3400 cm <sup>3</sup> (207,48 cu in)	3359 cm <sup>3</sup> (204,97 cu in)
Intake	Turbo		
Power	70 kW (94 Hp) at 2300 rpm (97/68EC)	83 kW (111,3 Hp) at 2200 rpm (97/68EC)	55,4 kW (74,29 Hp) at 2200 rpm (97/68EC)
Torque	392 Nm at 1400 rpm	450 Nm at 1400 rpm	372,4 Nm at 1400 rpm

Hydraulic circuit	
Pump	Piston pump-Variable cubic capacity
Flow	150 l/min
Pressure	260 bar(3771 psi)
Regulation	Load Sensing with flow sharing device (proportional simultaneous movements)
Control	Electro-hydraulic with 4-function joystick
Accessory plug flow	62 l/min
Hydraulic oil tank capacity	110 l(29 gal US)

Transmission	
Type	Hydrostatic with pump and variable cubic capacity engine, 4 permanent drive wheels
Control	Electro-hydraulic with 2/2 front, rear and neutral position selector
Speed in operating mode	0 - 8 km/h (5 mph)
Speed in road mode	0 - 30 km/h (18,6 mph) ( 25 km/h (15,53 mph) in compliance with current standards)
Slow approach	Yes-Inching pedal
Traction force	7100 daN(15961 lbf)
Negotiable slope	45 %
Axles	Epicyclic gears - Differential blocking on front axle
Swing axle	Yes - Automatic locking in handling mode

# G - Technical characteristics

## Braking circuit

Engine brake	Hydrostatic
Service brake	Multi-disc oil bath brake controlled by the brake pedal
Parking brake	Electrically-controlled multi-disc oil bath brake

## Cab

Interior width	940 mm
----------------	--------

The cab complies with the ROPS (ISO 3471) / FOPS (ISO 3449) European safety standard. Door with two separate sections, opening rear window with wiper, heating, ventilation and joystick with 4 proportional functions.

## Tyres

HTL 4014 (HTL 9045) - HTL 4017 (HTL 9055)	Type	400/80-24 (HAULOTTE® code : 4000085980)
HTL 3614 (HTL 8045) - HTL 3617 (HTL 8055)	Type	405/70-24 (HAULOTTE® code : 2326014870)
Option	Type	400/80-24 (HAULOTTE® code : 2326016330)

## Steering system

Inner turning radius on tyre	2400 mm
Outer turning radius on tyre	4500 mm
Outer turning radius with forks	6250 mm

## Electric circuit

Model	Perkins 1104D44T	Perkins 854E-34TA (Wall Flow DPF)	Kohler KDI 3404 TCR
Operating voltage	12 V	12 V	12 V
Battery	110 Ah	110 Ah	110 Ah
Alternator	100 A	100 A	90 A
Starter	3.2 kW (4.3 Hp)	3.2 kW (4.3 Hp)	3.2 kW (4.3 Hp)

# G - Technical characteristics

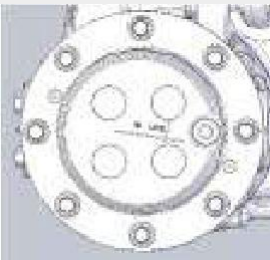
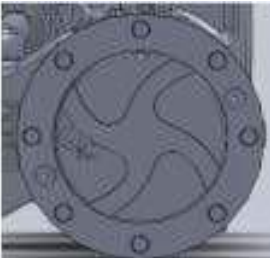
Filling capacity		
Fuel tank		130 l(34 gal US)
Hydraulic oil tank		110 l(29 gal US)
Front axle		8 l(2 gal US)
Rear axle		8,5 l(2 gal US)
Transfer case		1,25 l(0 gal US)
	(1)	
Front axle		6,5 l(1,7 gal US)
Rear axle		7,2 l(1,9 gal US)
Transfer case		0,7 l(0,18 gal US)
	(1)	
Engine oil (For machines fitted with engine PERKINS 1104D44T only)		8,4 l(2 gal US)
Engine oil (For machines fitted with engine PERKINS 854E-34TA only)		9,5 l(3 gal US)
Engine oil (For machines fitted with engine KOHLER KDI 3404 TCR only)		15,6 l(4 gal US) - Maximum 9,2 l(2 gal US) - Min.
Cooling		18 l(5 gal US)

(1) : Refer to the machine configuration to identify the logo that appears on the wheel reducer.



# G

## - Technical characteristics

### 1.2 - STANDARD EQUIPMENT

- Dual-element air filter
- Fuel filter with water separator
- Transmission oil filter
- 4 Drive and steer wheels
- Safety valves on hydraulic cylinders
- Auxiliary hydraulic circuit to the boom head
- Stabiliser and side tilt interlocking, with the boom raised
- Incremental approach movements possible via the Inching system
- Deactivation of aggravating movements in the event of overload
- Load moment indicating device with load status controller and 5 LED's in the cab: cut-off and sound signal with automatic speed deceleration at the limits of the capacity chart
- Automatic hydraulic locking of the rear axle
- Side tilt corrector : +10° / - 10°
- Pre-wiring for radio and loudspeakers
- Horn
- Visual hydraulic oil pressure gauge
- Indicator light confirming alignment of front and rear wheels for Road Mode
- Adjustable seat (height and armrest) with safety belt
- Adjustable steering column
- Power steering
- Metal protection above cab
- Tinted windows and sun visor
- Left and right exterior rearview mirrors
- Hour meter
- Boom angle indicator
- Mudguards
- Stabilizers with ground contact sensors
- Forks
- Manual fork carriage with 2 pins
- Front and rear towing brackets
- Road Mode wheel configuration selector button
- Beacon light
- Front and rear full beam headlights
- Presence of water in diesel LED

# G - Technical characteristics

## 1.3 - OPTIONAL EQUIPMENT

### 1.3.1 - Slings attached 3T (6,615 lb)

Slings attached	
Option number	4000072600
Nominal capacity	3T (6,615 lb)



#### 1.3.1.1 - Main components

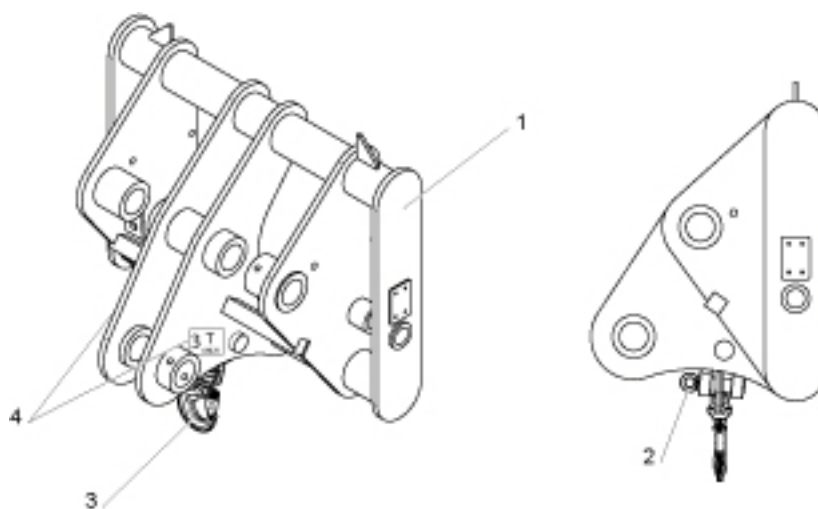

Marking	Description
1	Tool holder carriage
2	Shackle
3	Hook
4	Overload limitation label

#### 1.3.1.2 - Characteristics

Lifting hook mounted on tool holder carriage, designed to operate under dynamic and static load, in horizontal position.



The safety coefficient used is in compliance with the legislation on lifting apparatus or attachment tests.

# G - Technical characteristics

## 1.3.1.3 - Control

The joystick ( P211 ) controls movements of the boom and the option tilt (  Section C 2.5.8 - Joystick - Operator's manual).

## 1.3.1.4 - Operation

Operation instructions

The swivel in the hook is only to be used to align with the load and support it in a fixed position, it is not designed for rotation under load. The swivel head permits the hook to rotate and avoid the chains twisting.



**Do not use slings attached :**

- For pulling loads laterally.
- Under conditions of repeated cyclic fatigue : i.e. fast running on a bumpy surface.



**This option is designed for load lifting necessarily in horizontal position.**



**When using the jib, it is forbidden to use the carriage tilt (down or up) while there is a load on the jib.**



**It is strictly forbidden to move the load (drive the telescopic handler) with the jib in high position.**



**The load must be lifted with the mast positioned as specified on the load charts.**



**If it must be moved, the load must be kept in the low position. Speed of movement must not exceed 5 km/h (3,1 mph) and the load must be secured to the telescopic handler fork carriage.**

Working conditions

Raise or lower the boom to the appropriate height for lifting the load.

Lift the load smoothly and with the boom fully retracted.

Travel as specified  Section A - Safety precautions.

## 1.3.1.5 - Lubrication and maintenance



**If the hook is damaged, stop using the attachment immediately. Change it.**

# G

## - Technical characteristics

### 2 - Overall dimensions

General diagram HTL 4017 (HTL 9055) - HTL 4014 (HTL 9045)

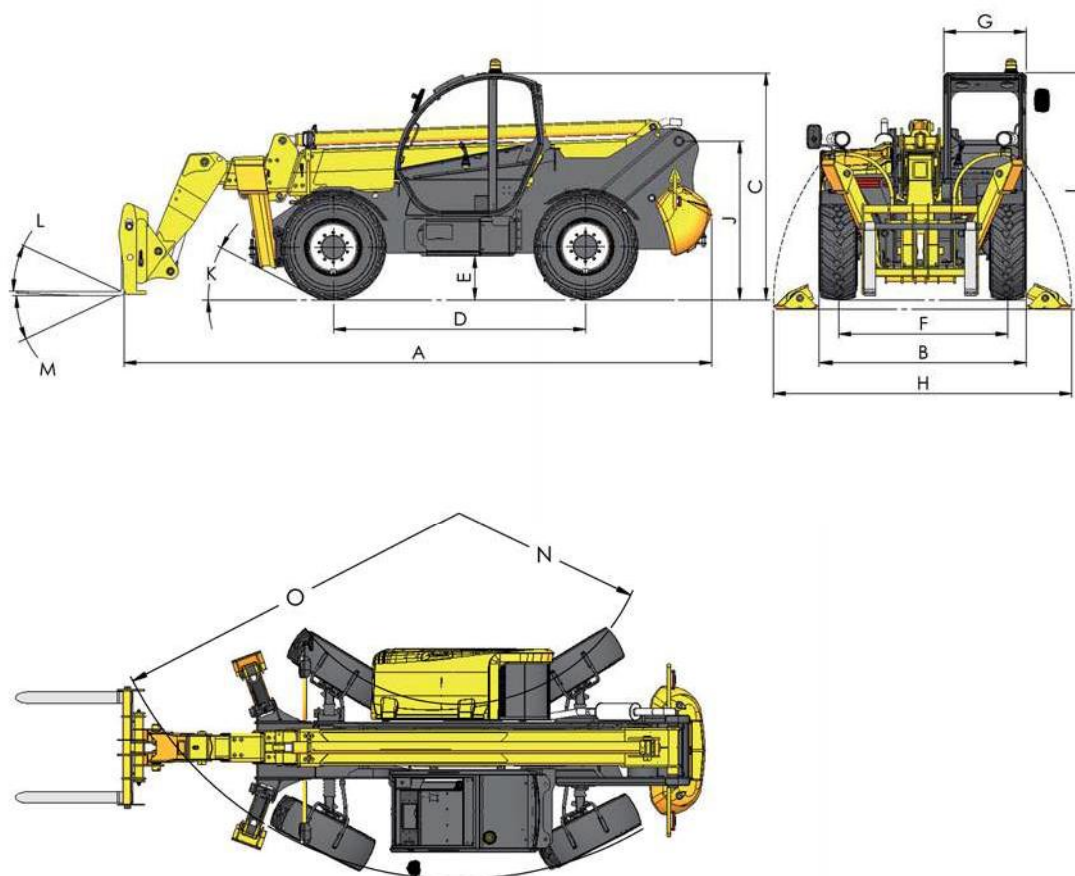

Overall dimension specifications

Marking	HTL 4017 (HTL 9055)		HTL 4014 (HTL 9045)	
	Mètre	Feet inch	Mètre	Feet inch
A	6,76	22 ft 2 in	6,47	21 ft 3 in
B	2,43	8 ft	2,43	8 ft
C	2,60	8 ft 6 in	2,60	8 ft 6 in
D	2,89	9 ft 6 in	2,89	9 ft 6 in
E	0,50	1 ft 8 in	0,50	1 ft 8 in
F	2,00	6 ft 7 in	2,00	6 ft 7 in
G	0,94	3 ft 1 in	0,94	3 ft 1 in
H	3,34	11 ft	3,34	11 ft
I	2,65	8 ft 8 in	2,65	8 ft 8 in
J	1,80	5 ft 11 in	1,80	5 ft 11 in
K		28 °		28 °
L		18 °		18 °
M		104 °		104 °
N	2,40	7 ft 10 in	2,40	7 ft 10 in
O	4,50	14 ft 9 in	4,50	14 ft 9 in

# G - Technical characteristics

## Technical characteristics

	HTL 4017 (HTL 9055)		HTL 4014 (HTL 9045)	
	Metric	Imperial	Metric	Imperial
Vehicule mass without accessory	11710 kg	25,821 lb	10420 kg	22,976 lb
Vehicule mass with fork	12000 kg	26,46 lb	10710 kg	23,616 lb
Total weight allowed on road	13000 kg	26,665 lb	13000 kg	26,665 lb
Total weight allowed in load : Gross vehicle weight rating	16000 kg	35,28 lb	16000 kg	35,28 lb

## Overall dimension specifications

Marking	HTL 3617 (HTL 8055)		HTL 3614 (HTL 8045)	
	Mètre	Feet inch	Mètre	Feet inch
A	6,58	21 ft 7 in	6,43	21 ft 1 in
B	2,44	8 ft	2,44	8 ft
C	2,60	8 ft 6 in	2,60	8 ft 6 in
D	2,89	9 ft 6 in	2,89	9 ft 6 in
E	0,50	1 ft 8 in	0,50	1 ft 8 in
F	1,93	6 ft 4 in	1,93	6 ft 4 in
G	0,94	3 ft 1 in	0,94	3 ft 1 in
H	3,34	11 ft	3,34	11 ft
I	2,71	8 ft 11 in	2,71	8 ft 11 in
J	1,82	6 ft	1,82	6 ft
K		28 °		28 °
L		18 °		18 °
M		104 °		104 °
N	2,40	7 ft 10 in	2,40	7 ft 10 in
O	4,50	14 ft 9 in	4,50	14 ft 9 in

## Technical characteristics

	HTL 3617 (HTL 8055)		HTL 3614 (HTL 8045)	
	Metric	Imperial	Metric	Imperial
Vehicule mass without accessory	11300 kg	24,917 lb	10050 kg	22,16 lb
Vehicule mass with fork	11590 kg	25,556 lb	10340 kg	22,8 lb
Total weight allowed on road	13000 kg	28,665 lb	12000 kg	26,46 lb
Total weight allowed in load : Gross vehicle weight rating	16000 kg	35,28 lb	15000 kg	33,075 lb

# G - Technical characteristics

## 3 - Working area

### 3.1 - MACHINE HTL 9055

#### Working area

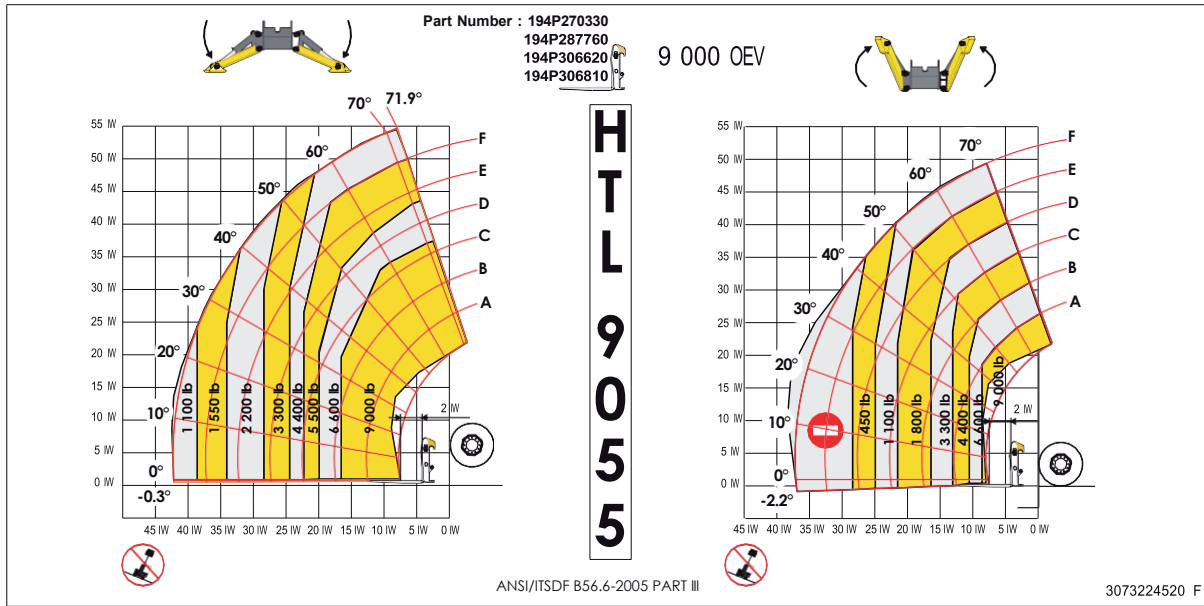

### 3.2 - MACHINE HTL 9045

#### Working area

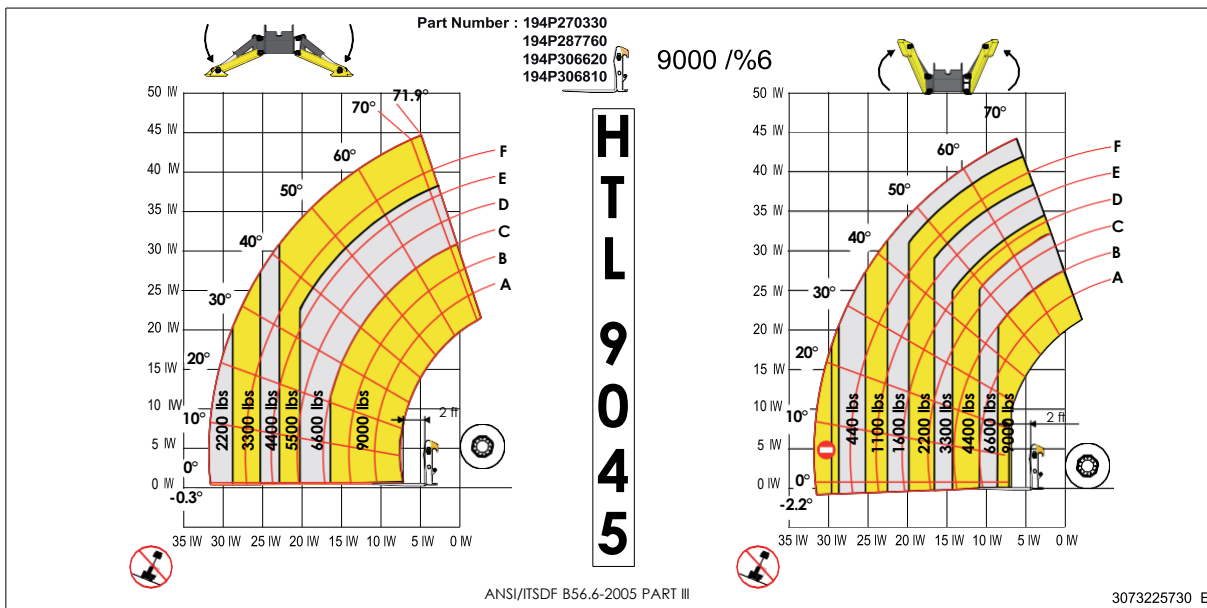

# G - Technical characteristics

## 3.3 - MACHINE HTL 8055

### Working area

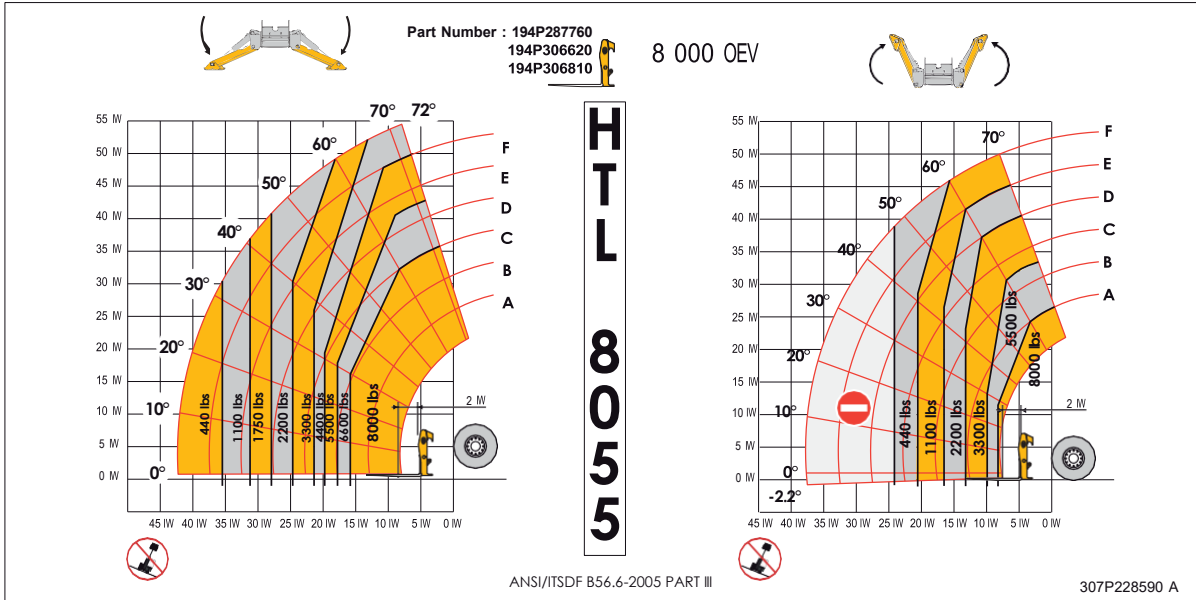

## 3.4 - MACHINE HTL 8045

### Working area

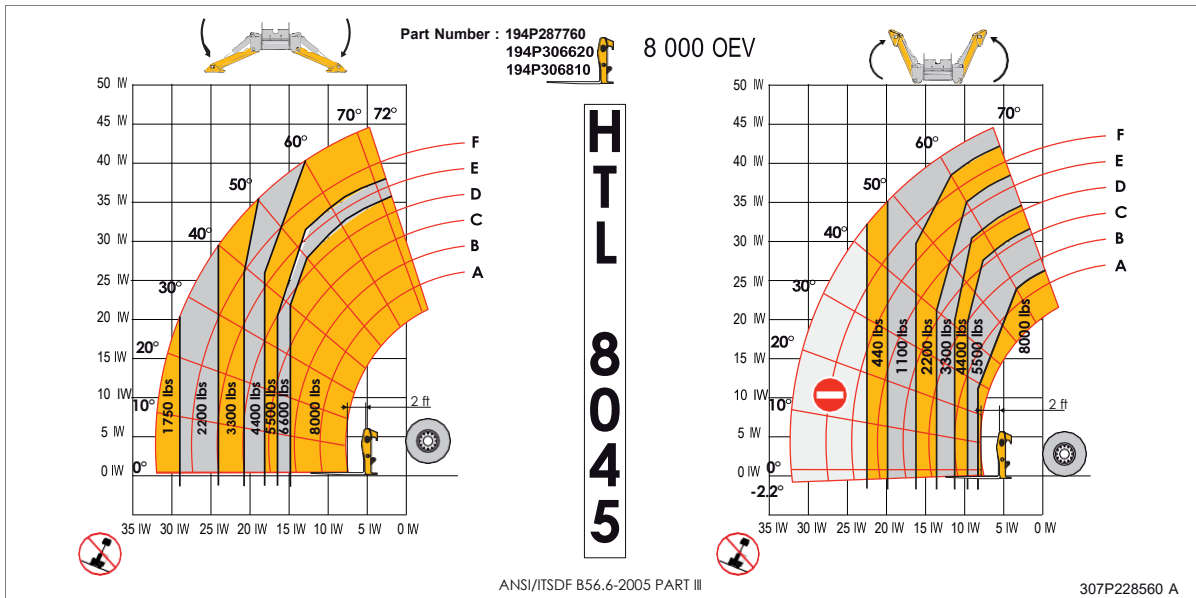

# G - Technical characteristics

## 4 - Noise emission level



The sound power values indicated in the technical characteristics tables are obtained in the following conditions :

- For machines equipped with internal combustion engines, the guaranteed acoustic level LWA (displayed on the product) and is measured in accordance with the method and the conditions described in Appendix III, Part B, Point 36 of the 2000/14/CE European directive.

The Telehandler's noise emission sound levels comply with :

- The European directives mentioned on the compliance certificate supplied with the machine.
- National road regulations.
- National work regulations.

The LWA noise emission level is shown on the machine.

To avoid any increase in noise emission, all panels and other sound-absorbing materials must be replaced in their original position after maintenance and repair work.



Do not modify the machine in a way that may increase noise emissions.

### Technical characteristics (For machines fitted with engine PERKINS 1104D44T only)

#### HTL 4014 (HTL 9045) - HTL 4017 (HTL9055) - HTL 3614 - HTL 3617

Noise emission level at driving station	75 dBA
Maximum noise emission level	105 dBA

### Technical characteristics (For machines fitted with engine PERKINS 854E-34TA only)

#### HTL 4014 (HTL 9045) - HTL 4017 (HTL9055) - HTL 3614 - HTL 3617

Noise emission level at driving station	75 dBA
Maximum noise emission level	106 dBA

### Technical characteristics (For machines fitted with engine KOHLER KDI 3404 TCR only)

#### HTL 4014 (HTL 9045) - HTL 4017 (HTL9055) - HTL 3614 - HTL 3617

Noise emission level at driving station	75 dBA
Maximum noise emission level	104 dBA

# G - Technical characteristics

## 5 - Telehandler vibration



The hand and feet vibration values indicated in the technical characteristics tables are obtained in the following conditions :

- The maximum quadratic mean value weighted as an acceleration frequency and the total value of the vibrations to which the hand-arm system is exposed have been measured on the products by simulating a cycle representative of normal use. The values meet the requirements of the 2006/42/CE machine directive.

The load and acceleration values for vibrations transmitted to the body are below the levels required by the various regulations. The measurements have been performed according to the currently applicable standards.

Hand and body vibration are measured in accordance with method and conditions described in standard ISO5349-1 and ISO2631-1.

### Technical characteristics

HTL 4014 (HTL 9045) - HTL 4017 (HTL 9055) - HTL 3614 - HTL 3617

Hand - feet vibration	< 2,5 m/s <sup>2</sup>
Body vibration	< 0,5 m/s <sup>2</sup>

# H - Lubrication and maintenance

## 1 - Maintenance guidelines

The Telehandler was given an arbitrary Design Life of 10 years at the design stage of the product. There are a number of factors which can affect the design life including but not limited to, severity of operating conditions/routine maintenance which should be carried out in accordance with this manual. Severity of operating conditions may require a reduction in time between maintenance periods. These factors are amongst a number, which may extend or shorten the Design Life of the product. Local Regulations may also require Enhanced Periodic Inspection/ 10 year inspection to be carried out on the product to extend its service life beyond the Design life.

Perform the maintenance in accordance with the maintenance schedule set out on the following pages.

- Adapt the frequency of maintenance according to use to obtain maximum service life.
- Read all of the instructions in the guide before starting Telehandler maintenance.
- Follow the Telehandler shut-down procedure before performing any servicing or maintenance
- For all checks, park the Telehandler on flat ground, stop the engine, actuate the parking brake and lower the booms to the parked position.
- To obtain accurate fluid level readings ensure that the machine is on level ground.
- Before each check : top-up, refill or lubrication check, you must clean the filler inlets, the filler caps and the grease points.
- After lubricating the machine, actuate all functions several times to distribute the lubricants. Perform all these maintenance procedures without any accessories fitted.
- Check the state of the filling plug seals; do not forget to replace them if they are damaged or worn.
- Maintain the Telehandler and associated equipment, especially the brakes and the steering, in good condition to protect your safety and to comply with the statutory requirements.



**Do not modify or alter the machine or its equipment without the manufacturer's permission.**

- Always check the pins, the bushes, the fastening pins, etc... daily
- Incorrect or poorly performed maintenance can damage the machine.



**Stop the engine before opening the canopy : Presence of moving parts that could cause bodily injuries.**

- Check that there are no tools or other objects left in the engine compartment after maintenance work has been completed.
- Drain the engine after operation when the oil is hot.

***N.B.-:** Mechanical vibrations may occur on the machine during the first 50 hours of operation. This phenomenon will disappear after the internal combustion engine's break-in period.*

- Remove the keys from the ignition switch during maintenance work.



**Do not stand close to the front or rear of the machine while the engine is running.**

- Batteries, plastic objects or other components of a toxic nature that could be harmful to the environment must be disposed of in a way that does not harm. Ensure that they must be disposed of in a way that does not harm.

***N.B.-:** Accumulators are pressurized vessels. It is the user's responsibility to refer to the national regulations in force in the country of use concerning their use and disposal.*

# H - Lubrication and maintenance

## 2 - Maintenance instructions



Before operate maintenance operation on hydraulic component or component localized under the boom, use safety prop as follow :

- Place the boom to 24° - 25° (without load and machine on wheels).
- Put the safety prop in the boom in the same way that it is shown in the picture (it is prohibited to lift up or lift down the boom with the safety prop placed).
- Proceed to work under boom.

Safety prop



- Wear protective clothing and personal protection equipment supplied or required by the job conditions.



Do not wear loose fitting clothes or jewellery that could get caught on controls or moving parts.



Do not perform Telehandler servicing or maintenance with the engine running.

- If the engine is started inside a building, there must be sufficient ventilation to remove the exhaust gases.
- Always refit the guards and plates that have been dismantled before starting the machine.
- Paintwork shall be performed in well-ventilated premises using approved protective equipment.
- The engine cooling system operates under pressure. The pressure is regulated by the radiator cap.



Never dismantle a component from the system while it is hot. Always loosen the radiator cap slowly and let the pressure escape before removing it completely.

# H - Lubrication and maintenance

- To prevent any risks of fire or explosion, keep any naked flames away from the battery. To prevent any risk of sparks that could cause an explosion, use the battery cables in accordance with the instructions provided in this manual.
- Hydraulic oil leaks or fluid under pressure can cause serious injury.



**Do not use your hands to check for oil leaks. Search for leaks with a piece of cardboard or paper.**

*N.B.-: Stop the engine and depressurize in the system before intervening on the hydraulic system.*

*N.B.-: Check that all connections are tight before restarting the machine or pressurizing the system.*



**Do not intervene on the air-conditioning system. A refrigerant fluid leak can cause serious injury. Contact HAULOTTE Services®.**

- The diesel in the injection system is under high pressure. For any operations or adjustments, please contact a qualified technician or your dealer. Failure to comply with these guidelines can result in serious injury.



**Never let anyone stand or work under the boom when it is raised unless the safety prop is installed and the cylinder is secured.**

 **Section H 7.2 - Hydraulics.**



**Never try to repair or tighten pressurized pipes or hoses.**



**Never perform lubrication or adjustment operations when the machine is in motion or when the engine is running.**

- Protective equipment must be worn when performing any service/repair on the machine.

A

B

C

D

E

F

G

H

I

# H - Lubrication and maintenance

Consumables (Fuels - Engine oil - Coolant level ...) - For machines fitted with engine PERKINS 854E-34TA or KOHLER KDI 3404 TCR only

## Fuels

**N.B.:-**The fuel to be used is regulated by national laws; refer to these requirements to define the appropriate fuel. Using unsuitable fuel may cause diminished performance, difficulties starting, excessive pollution and premature wear. To establish the type of fuel suitable for the engine fitted on your HAULOTTE® machine, please refer to the engine manufacturer's manual. The engine may not be covered by the warranty in case of damage caused by using unsuitable fuel.



The engine fitted in your HAULOTTE® machine is designed to run only with diesel fuel containing a very low sulphur content. If the ASTM D5453, ASTM D2622 or ISO 20846 ISO 20884 test methods are used, the level of sulphur in the low sulphur content diesel fuel must be less than 15 ppm (mg/kg) or 0,0015 % by weight.



Using diesel fuel containing more than 15 ppm of sulphur in these engines may damage the anti-pollution control systems (sometimes irreversibly) or reduce the service frequency.

Table of technically permitted fuels

Engines	Fuels			
	European gas oil according to EN590	European fuel oil according to BS2869 2010 class A2 or UE equivalent	American gas oil according to ASTM D975 Grade 1D S15 American gas oil according to ASTM D975 Grade 2D S15	Japanese gas oil according to JIS K2204
PERKINS 854E-34TA (Wall Flow DPF)	✓	✓	✓	✓
KOHLER KDI 3404 TCR	✓	✓	✓	✓

Compliant



Not compliant



# H - Lubrication and maintenance

## Engine oil



Only use API CJ-4 oil or equivalent. Please refer to the table of permitted engine oils.



Not using the appropriate specification of engine oil may reduce the service life of the engine and post-treatment system.

API CJ-4 and ACEA E9 oil categories have the following chemical limits :

- 0,1 % maximum sulfated ash
- 0,12 % maximum phosphorous
- 0,4 % maximum sulfur

Table of permitted engine oils

Engines	Engine oil specification
PERKINS 854E-34TA (Wall Flow DPF)	API CJ-4 ACEA E9 ECF-3
KOHLER KDI 3404 TCR	API CJ-4 ACEA E9 ACEA E7 ACEA E6



CC, CD, CD-2, CF-4, CG-4, CH-4, CI-4 engine oils, not approved, must not be used.

A

B

C

D

E

F

G

H

I

# H - Lubrication and maintenance

## Coolant

**N.B.:-** The engine fitted in your HAULOTTE® machine must operate with a 1:1 solution of water and glycol. This concentration allows the NOx reduction system to operate correctly in environments where the temperatures are high.

Glycol in the coolant helps to provide protection against the following conditions :

- Boiling
- Freezing
- Cavitation of the water pump

### Coolant service life

Coolant type	Service life <sup>1</sup>
Commercial heavy-duty antifreeze that meets ASTM D6210	Every 3000 hours of operation (or every 2 years)
Water and commercial SCA inhibitor	Every 3000 hours of operation (or once a year)

1 :

Use the interval that occurs first. The cooling system must also be flushed out at this time.

# H - Lubrication and maintenance

## 3 - Repairs and adjustments

Significant repairs or adjustments on the safety systems or elements (concerns mechanics, hydraulics and electrics).

Any modifications not approved by HAULOTTE® are not permitted.

The manufacturer's product liability will be void if the work specified above is not performed by HAULOTTE® approved staff or if the spare parts are not original spare parts.

A

B

C

D

E

F

G

H

I

# H - Lubrication and maintenance

## 4 - Lubrication and maintenance schedule

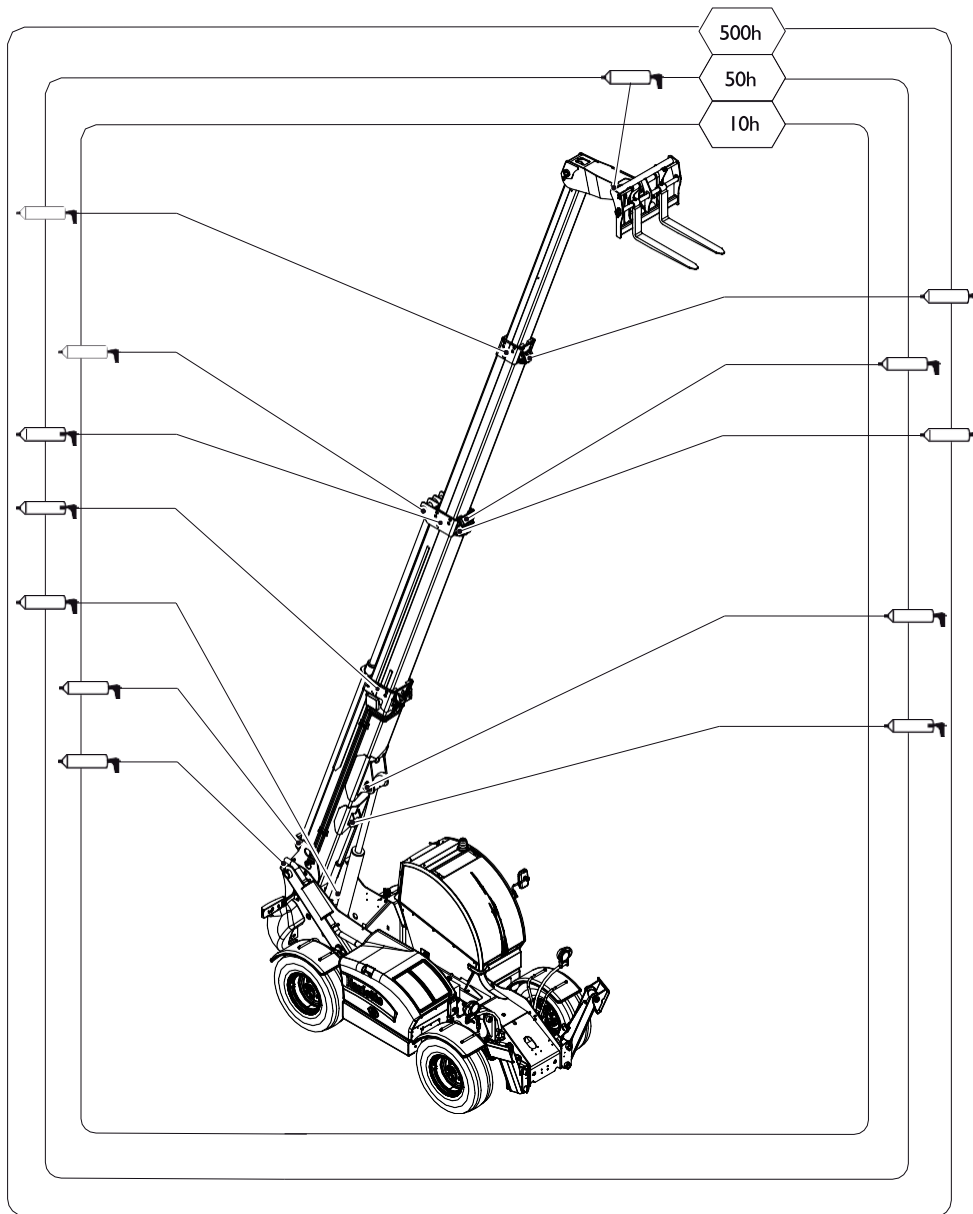

# H - Lubrication and maintenance

For machines fitted with : Engine PERKINS 1104D44T

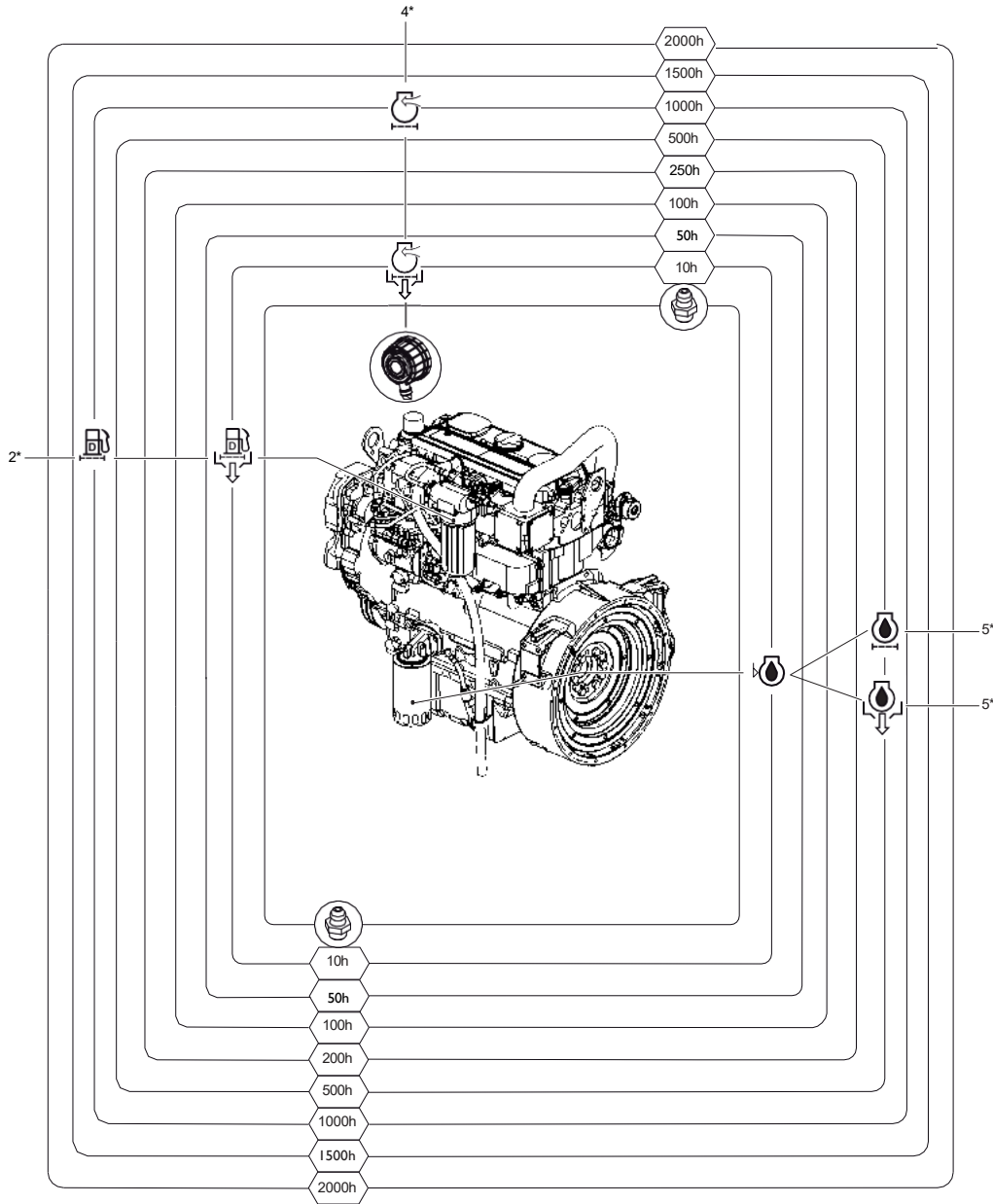

A

B

C

D

E

F

G

H

I

# H - Lubrication and maintenance

For machines fitted with : Engine PERKINS 854E-34TA

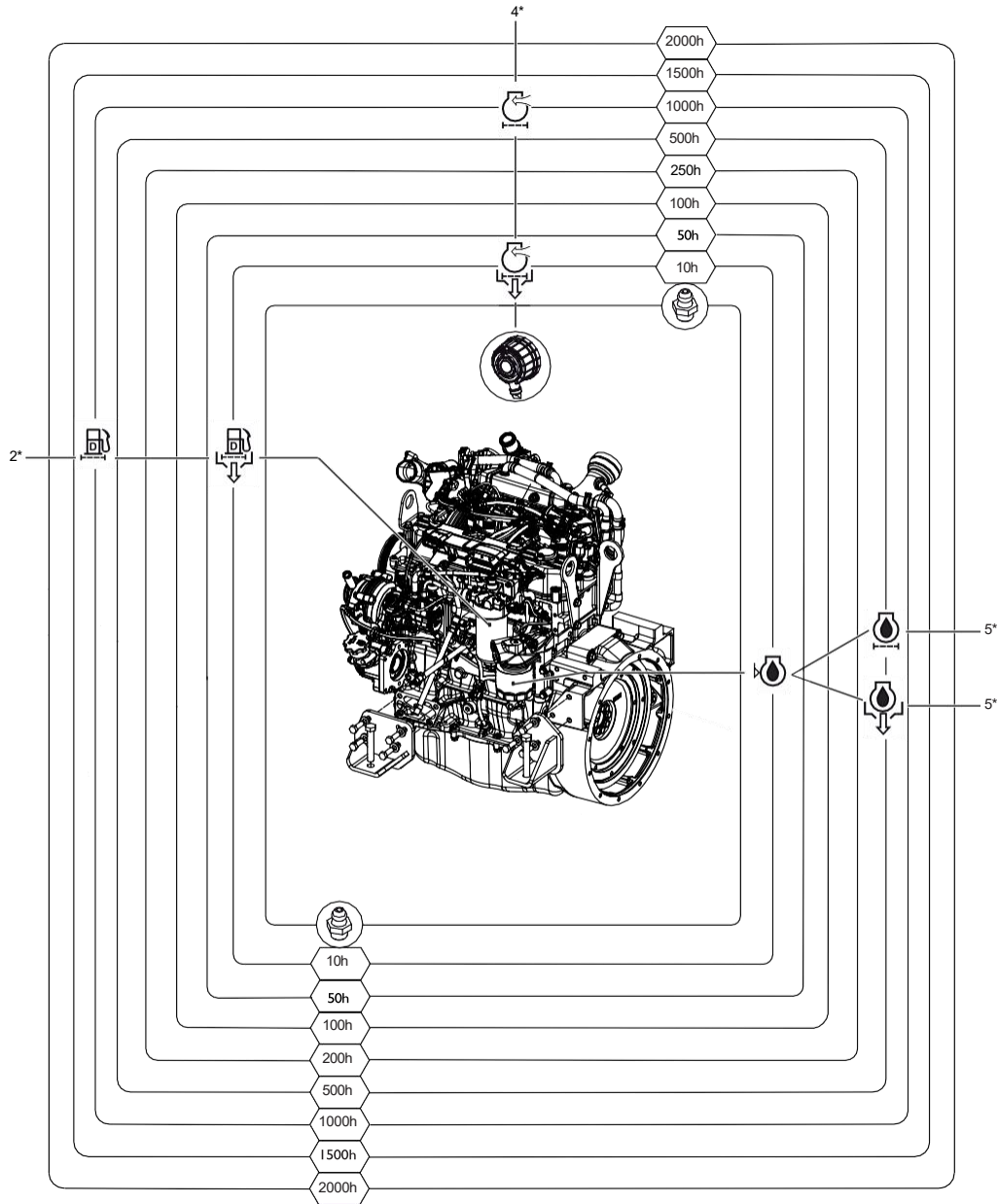

# H - Lubrication and maintenance

For machines fitted with : Engine KOHLER KDI 3404 TCR

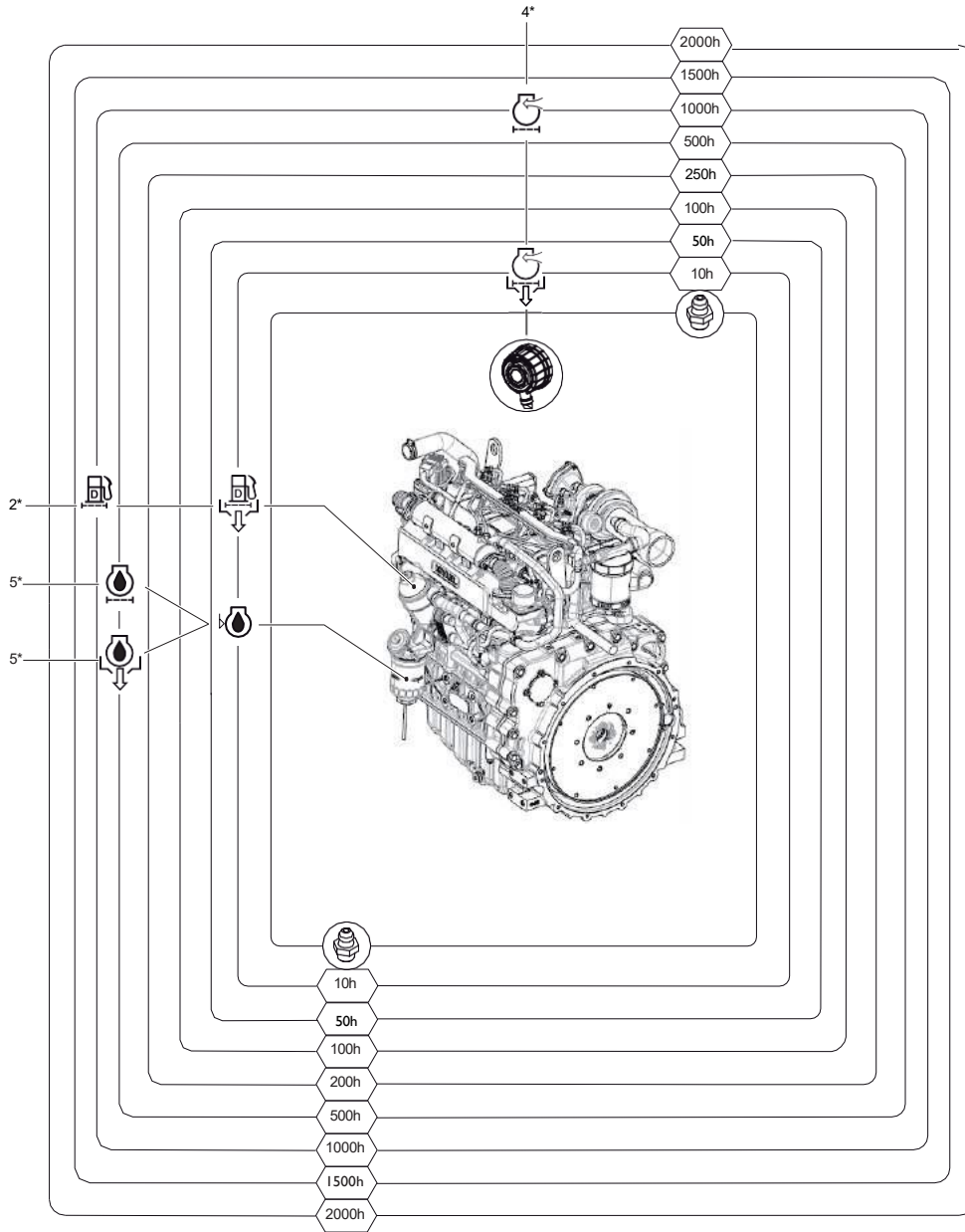

A

B

C

D

E

F

G

H

I

# H - Lubrication and maintenance

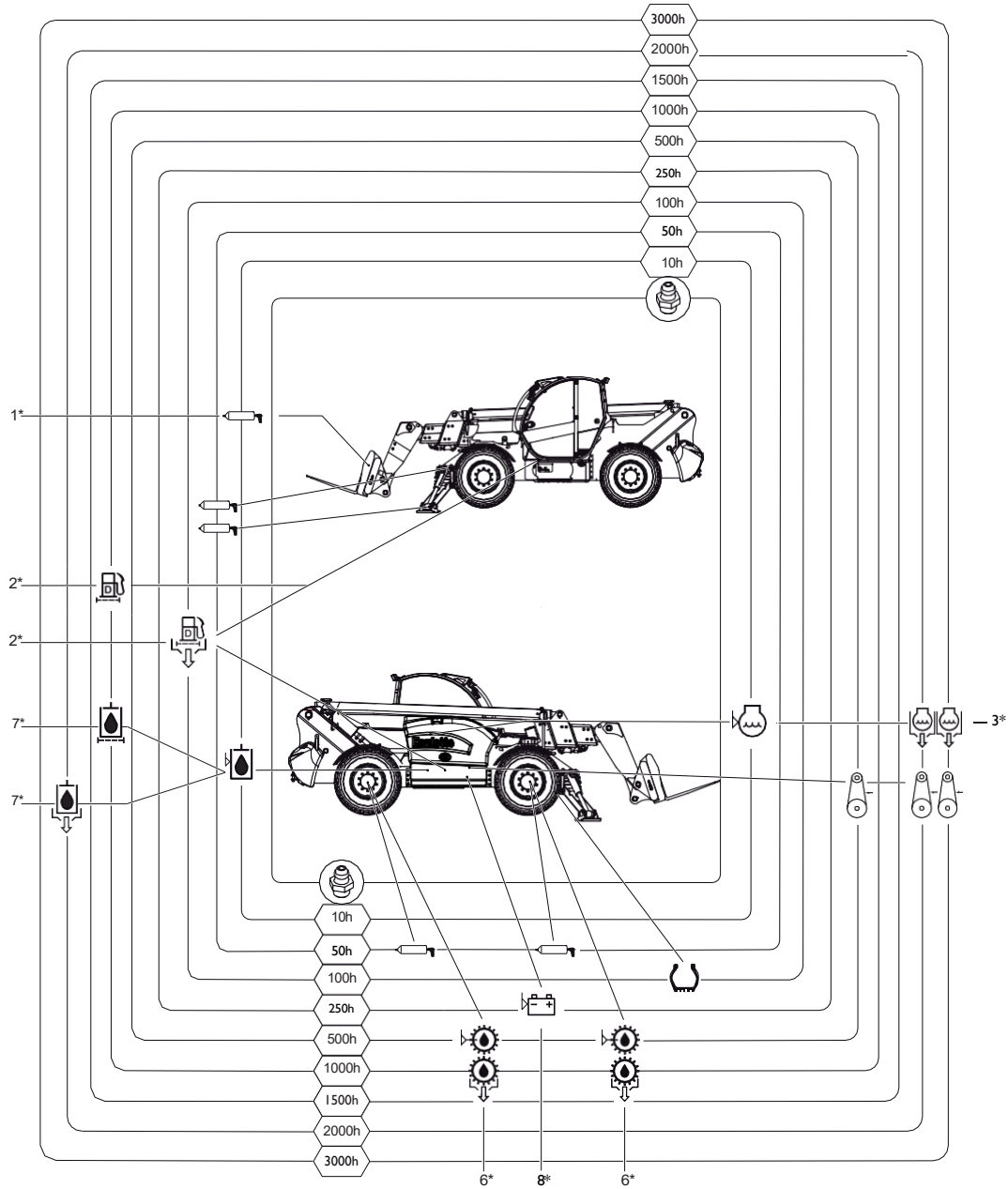

# H - Lubrication and maintenance

## Description of the components

Symbol	Marking	Description
		Check the level
		Filter
		Oil change
	1*	Lubrication
	2*	Diesel circuit
	3*	Cooling system
	4*	Air filter (system)
	5*	Internal combustion engine
	6*	Travel axles
	7*	Hydraulic circuit
	8*	Battery

A

B

C

D

E

F

G

H

I











# H - Lubrication and maintenance

## 5 - General program / Recommendations

The design service life of the products covered by this manual is for a period of 10 years. This service life is based on the machine being maintained within the maintenance regime set down in the Maintenance Manual supplied with the product.

It must be noted that should the product be subject to ongoing use in harsh environments, then the effective service life will be reduced. Contact Haulotte Services for further advice.

The time periods below are recommended for fuel-powered machines in normal use.

Symbol	Meaning	Symbol	Meaning
	Visual inspections		Systematic replacement Operation requiring HAULOTTE Services® authorisation
	Check-Test See user manual or machine maintenance book		Visual inspection with dismantling and exchange or replacement if necessary Operation requiring HAULOTTE Services® authorisation Increase in periodical inspections
	Check level		Tightening (bolt, etc.)
	Lubrication-Lubrication		Tolerance (clearance lubrication)
	Oil change		Static and dynamic tests For countries where machines are not subject to controlled periodic maintenance

1 - Increase in periodical inspections

2 - For countries where machines are not subject to controlled periodic maintenance

# H - Lubrication and maintenance



**Increase in periodical inspections :** Depending on the condition of certain critical components after 5000 hours, the maintenance staff may have to reduce the interval between periodical inspections and maintenance. If the decision is made not to replace a part, the part concerned must be recorded in the inspection schedule.

Each day and before the beginning of a new work period and on each change of operator, the machine must be subjected to a visual inspection and a complete functional test. Any repairs required must be performed before the machine is used, its correct operation depends on it. Inspect the following items :

- State of the structure's parts : Chassis, Boom, jib, platform.
  - Absence of cracks, broken parts, damaged paint.
  - No distortion in metal components or visible damage.
  - Absence of foreign objects at the ends of boom/attachments.
  - Presence and check the original position of the platform control box sliding bar.
- Cylinders :
  - No leaks : Refer to the Maintenance book.
  - No rust and abrasions on the cylinder rod.
  - Absence of foreign objects on all surfaces.
- Steering system : Wheels, Axles, Brake and Tyres :
  - No cracks, distortions, damaged paint or other faults.
  - No missing or loose bolts.
  - Condition of the tyres (cuts, excessive wear, etc.)
- Condition of the pulley system :
  - No excessive clearance : Refer to the Maintenance book.
  - No missing or loose bolts.
  - Absence of foreign objects on all surfaces.
  - Grease the extension system if necessary.

# H - Lubrication and maintenance

Area	Intervals									
	Daily	Every 50 hours	Every 100 hours	Every 250 hours	Every 500 hours	Every 1000 hours	Every 1500 hours	Every 2000 hours	Every 3000 hours	Every 5000 hours
General checks										
Structure parts										
Windscreen washer fluid										
Oil, water, fuel leaks										
Boom extension chain tension										
Chain wear										
Appearance of the mechanical parts, hydraulic hoses and wiring										
Attachment device : nuts and bolts and hydraulic fitting										
Operation of the work lighting controls, the light indicators, display load moment indicator										
Diesel engine operation										
State of anti-slip parts										
State of tires and inflation pressure										
Wheel nut torque										
Lubrication										
Cylinder pins										
Boom bottom shaft										
Telescopic boom pads										
Suspension, driver seat rails										
Diesel circuit										
Condensation										
Diesel pre-filter										
Filter										
Cooling system										
Coolant										
State of the hoses and collars								(1)	(2)(3)	
Radiator slats										
Cleanliness of the radiator's protection grill										
Air filter (system)										
Remove the dust										
Primary air filter										
Secondary air filter										
Internal combustion engine (See manufacturer's guide)										

# H - Lubrication and maintenance

Oil													
Oil filter cartridge													
Diesel particulate filter										(2)			
Engine crankcase breather								(2)					
Engine mounting													
Glow plugs													
Belt tension									(1)		(2)		(3)
Travel axles (See manufacturer's guide)													
Front axle : Reducer + differential + transfer case on front axle + pivots													
Rear axle : Reducer + differential + pivots													
Epicyclic gears													
Hydraulic circuit													
Hydraulic oil													
Attachment hydraulic oil													
Transmission hydraulic filter													
Pressures													
Battery													

- (1) : For machines fitted with : Engine PERKINS 1104D44T.
- (2) : For machines fitted with : Engine PERKINS 854E-34TA.
- (3) : For machines fitted with : Engine KOHLER KDI 3404 TCR.











A  
B  
C  
D  
E  
F  
G

H  
I

# H - Lubrication and maintenance

## 6 - Detailed program

The time periods below are recommended for fuel-powered machines in normal use.

Symbol	Meaning	Symbol	Meaning
	Visual inspections		Systematic replacement Operation requiring HAULOTTE Services® authorisation
	Check-Test See user manual or machine maintenance book		Visual inspection with dismantling and exchange or replacement if necessary Operation requiring HAULOTTE Services® authorisation Increase in periodical inspections
	Check level		Tightening (bolt, etc.)
	Lubrication-Lubrication		Tolerance (clearance lubrication)
	Oil change		Static and dynamic tests For countries where machines are not subject to controlled periodic maintenance

1 - Increase in periodical inspections

2 - For countries where machines are not subject to controlled periodic maintenance



During the periodic inspection of the 2000 h (visual inspection with dismantling and exchange or replacement if necessary), a record must be made of all parts that have been dismantled but not replaced

# H - Lubrication and maintenance

500 h or 6 month service			
Area	Type of intervention	Area	Type of intervention
<b>General checks</b>		<b>Lubrication</b>	
Windscreen washer fluid		Cylinder pins	
Oil, water, fuel leaks		Boom bottom shaft	
Boom extension chain tension		Telescopic boom pads	
Appearance of the mechanical parts, hydraulic hoses and wiring		Suspension, driver seat rails	
Attachment device : nuts and bolts and hydraulic fitting		<b>Diesel circuit</b>	
Operation of the work lighting controls, the light indicators, display load moment indicator		Condensation	
Diesel engine operation		Pre-filter	 (1)(2)
State of anti-slip parts		Filter	
State of tires and inflation pressure		<b>Air filter (system)</b>	
Wheel nut torque		Remove the dust	
<b>Internal combustion engine (See manufacturer's guide)</b>		Primary air filter	
Oil		Secondary air filter	
Oil filter cartridge		<b>Cooling system</b>	
Belt tension		Coolant	
<b>Travel axles (See manufacturer's guide)</b>		Hoses and collars	
Front axle : Reducer + differential + transfer case on front axle + pivots		Radiator slats	
Rear axle : Reducer + differential + pivots		Cleanliness of the radiator's protection grill	
Epicyclic gears		<b>Battery</b>	
<b>Hydraulic circuit</b>		Level	
Hydraulic oil			
Date : Number of hours : Intervenor : HAULOTTE Services® contract number : Intervention sheet number : Signature :		Comments	

(1) : For machines fitted with : Engine PERKINS 1104D44T.  
 (2) : For machines fitted with : Engine PERKINS 854E-34TA.



# H - Lubrication and maintenance

1000 h or 12 month service			
Area	Type of intervention	Area	Type of intervention
<b>General checks</b>		<b>Lubrication</b>	
Windscreen washer fluid		Cylinder pins	
Oil, water, fuel leaks		Boom bottom shaft	
Boom extension chain tension		Telescopic boom pads	
Appearance of the mechanical parts, hydraulic hoses and wiring		Suspension, driver seat rails	
Attachment device : nuts and bolts and hydraulic fitting		<b>Diesel circuit</b>	
Operation of the work lighting controls, the light indicators, display load moment indicator		Condensation	
Diesel engine operation		Pre-filter	
State of anti-slip parts		Filter	
State of tires and inflation pressure		<b>Air filter (system)</b>	
Wheel nut torque		Remove the dust	
Chain wear		Primary air filter	
<b>Internal combustion engine (See manufacturer's guide)</b>		Secondary air filter	
Oil		<b>Cooling system</b>	
Oil filter cartridge		Coolant	
Belt tension		Hoses and collars	
Engine mounting		Radiator slats	
Glow plugs		Cleanliness of the radiator's protection grill	
<b>Travel axles (See manufacturer's guide)</b>		<b>Hydraulic circuit</b>	
Front axle : Reducer + differential + transfer case on front axle + pivots		Hydraulic oil	
Rear axle : Reducer + differential + pivots		Attachment hydraulic oil	
Epicyclic gears		Transmission hydraulic filter	
<b>Battery</b>			
Level			
Date :		<b>Comments</b>	
Number of hours :			
Intervenor :			
HAULOTTE Services® contract number :			
Intervention sheet number :			
Signature :			

# H - Lubrication and maintenance

1500 h or 18 month service			
Area	Type of intervention	Area	Type of intervention
<b>General checks</b>		<b>Lubrication</b>	
Windscreen washer fluid		Cylinder pins	
Oil, water, fuel leaks		Boom bottom shaft	
Boom extension chain tension		Telescopic boom pads	
Appearance of the mechanical parts, hydraulic hoses and wiring		Suspension, driver seat rails	
Attachment device : nuts and bolts and hydraulic fitting		<b>Diesel circuit</b>	
Operation of the work lighting controls, the light indicators, display load moment indicator		Condensation	
Diesel engine operation		Pre-filter	
State of anti-slip parts		Filter	
State of tires and inflation pressure		<b>Air filter (system)</b>	
Wheel nut torque		Remove the dust	
<b>Internal combustion engine (See manufacturer's guide)</b>		Primary air filter	
Oil		Secondary air filter	
Oil filter cartridge		<b>Cooling system</b>	
Belt tension		Coolant	
Engine crankcase breather	 (1)	Hoses and collars	
<b>Travel axles (See manufacturer's guide)</b>		Radiator slats	
Front axle : Reducer + differential + transfer case on front axle + pivots		Cleanliness of the radiator's protection grill	
Rear axle : Reducer + differential + pivots		<b>Battery</b>	
Epicyclic gears		Level	
<b>Hydraulic circuit</b>			
Hydraulic oil			
Date : Number of hours : Intervenor : HAULOTTE Services® contract number : Intervention sheet number : Signature :		Comments	

(1) : For machines fitted with : Engine PERKINS 854E-34TA.

A  
B  
C  
D  
E  
F  
G

H  
I

# H - Lubrication and maintenance

2000 h service			
Area		Type of intervention	Type of intervention
<b>General checks</b>			<b>Lubrication</b>
Windscreen washer fluid			Cylinder pins
Oil, water, fuel leaks			Boom bottom shaft
Boom extension chain tension			Telescopic boom pads
Appearance of the mechanical parts, hydraulic hoses and wiring			Suspension, driver seat rails
Attachment device : nuts and bolts and hydraulic fitting		<b>Diesel circuit</b>	
Operation of the work lighting controls, the light indicators, display load moment indicator		Condensation	
Diesel engine operation		Pre-filter	
State of anti-slip parts		Filter	
State of tires and inflation pressure		<b>Air filter (system)</b>	
Wheel nut torque		Remove the dust	
Chain wear		Primary air filter	
<b>Internal combustion engine (See manufacturer's guide)</b>		Secondary air filter	
Oil		<b>Cooling system</b>	
Oil filter cartridge		Coolant	
Belt tension	(1)  (2)	Hoses and collars	
Engine mounting		Radiator slats	
Glow plugs		Cleanliness of the radiator's protection grill	
<b>Travel axles (See manufacturer's guide)</b>		<b>Hydraulic circuit</b>	
Front axle : Reducer + differential + transfer case on front axle + pivots		Hydraulic oil	
Rear axle : Reducer + differential + pivots		Attachment hydraulic oil	
Epicyclic gears		Transmission hydraulic filter	
<b>Battery</b>		Pressures	
Level			
Date : Number of hours : Intervenor : HAULOTTE Services® contract number : Intervention sheet number : Signature :		<b>Comments</b>	

(1) : For machines fitted with : Engine PERKINS 1104D44T.

(2) : For machines fitted with : Engine PERKINS 854E-34TA.

# H - Lubrication and maintenance

2500 h service			
Area	Type of intervention	Area	Type of intervention
<b>General checks</b>		<b>Lubrication</b>	
Windscreen washer fluid		Cylinder pins	
Oil, water, fuel leaks		Boom bottom shaft	
Boom extension chain tension		Telescopic boom pads	
Appearance of the mechanical parts, hydraulic hoses and wiring		Suspension, driver seat rails	
Attachment device : nuts and bolts and hydraulic fitting		<b>Diesel circuit</b>	
Operation of the work lighting controls, the light indicators, display load moment indicator		Condensation	
Diesel engine operation		Pre-filter	
State of anti-slip parts		Filter	
State of tires and inflation pressure		<b>Air filter (system)</b>	
Wheel nut torque		Remove the dust	
<b>Internal combustion engine (See manufacturer's guide)</b>		Primary air filter	
Oil		Secondary air filter	
Oil filter cartridge		<b>Cooling system</b>	
Belt tension		Coolant	
<b>Travel axles (See manufacturer's guide)</b>		Hoses and collars	
Front axle : Reducer + differential + transfer case on front axle + pivots		Radiator slats	
Rear axle : Reducer + differential + pivots		Cleanliness of the radiator's protection grill	
Epicyclic gears		<b>Battery</b>	
<b>Hydraulic circuit</b>		Level	
Hydraulic oil			
Date : Number of hours : Intervenor : HAULOTTE Services® contract number : Intervention sheet number : Signature :		Comments	

A

B

C

D

E

F

G

H

I

# H - Lubrication and maintenance

3000 h service			
Area	Type of intervention	Area	Type of intervention
<b>General checks</b>		<b>Battery</b>	
Windscreen washer fluid		Level	
Oil, water, fuel leaks		<b>Lubrication</b>	
Boom extension chain tension		Cylinder pins	
Appearance of the mechanical parts, hydraulic hoses and wiring		Boom bottom shaft	
Attachment device : nuts and bolts and hydraulic fitting		Telescopic boom pads	
Operation of the work lighting controls, the light indicators, display load moment indicator		Suspension, driver seat rails	
Diesel engine operation		<b>Diesel circuit</b>	
State of anti-slip parts		Condensation	
State of tires and inflation pressure		Pre-filter	
Wheel nut torque		Filter	
Chain wear		<b>Air filter (system)</b>	
<b>Internal combustion engine (See manufacturer's guide)</b>		Remove the dust	
Oil		Primary air filter	
Oil filter cartridge		Secondary air filter	
Diesel particulate filter	 (1)	<b>Cooling system</b>	
Alternator belt	 (1)	Coolant	(1)  (2) (3)
Engine crankcase breather	 (1)	Hoses and collars	
Belt tension	 (2)	Radiator slats	
Engine mounting		Cleanliness of the radiator's protection grill	
Glow plugs		<b>Hydraulic circuit</b>	
<b>Travel axles (See manufacturer's guide)</b>		Hydraulic oil	
Front axle : Reducer + differential + transfer case on front axle + pivots		Attachment hydraulic oil	
Rear axle : Reducer + differential + pivots		Transmission hydraulic filter	
Epicyclic gears			
<b>Date :</b> <b>Number of hours :</b> <b>Intervenor :</b> <b>HAULOTTE Services® contract number :</b> <b>Intervention sheet number :</b> <b>Signature :</b>		<b>Comments</b>	

(1) : For machines fitted with : Engine PERKINS 854E-34TA.  
 (2) : For machines fitted with : Engine PERKINS 1104D44T.  
 (3) : For machines fitted with : Engine KOHLER KDI 3404 TCR.

# H - Lubrication and maintenance

3500 h service			
Area	Type of intervention	Area	Type of intervention
<b>General checks</b>		<b>Lubrication</b>	
Windscreen washer fluid		Cylinder pins	
Oil, water, fuel leaks		Boom bottom shaft	
Boom extension chain tension		Telescopic boom pads	
Appearance of the mechanical parts, hydraulic hoses and wiring		Suspension, driver seat rails	
Attachment device : nuts and bolts and hydraulic fitting		<b>Diesel circuit</b>	
Operation of the work lighting controls, the light indicators, display load moment indicator		Condensation	
Diesel engine operation		Pre-filter	
State of anti-slip parts		Filter	
State of tires and inflation pressure		<b>Air filter (system)</b>	
Wheel nut torque		Remove the dust	
<b>Internal combustion engine (See manufacturer's guide)</b>		Primary air filter	
Oil		Secondary air filter	
Oil filter cartridge		<b>Cooling system</b>	
Belt tension		Coolant	
<b>Travel axles (See manufacturer's guide)</b>		Hoses and collars	
Front axle : Reducer + differential + transfer case on front axle + pivots		Radiator slats	
Rear axle : Reducer + differential + pivots		Cleanliness of the radiator's protection grill	
Epicyclic gears		<b>Battery</b>	
<b>Hydraulic circuit</b>		Level	
Hydraulic oil			
Date : Number of hours : Intervenor : HAULOTTE Services® contract number : Intervention sheet number : Signature :		Comments	

A

B

C

D

E

F

G

H

I

# H - Lubrication and maintenance

4000 h service			
Area		Type of intervention	Type of intervention
<b>General checks</b>			<b>Lubrication</b>
Windscreen washer fluid			Cylinder pins
Oil, water, fuel leaks			Boom bottom shaft
Boom extension chain tension			Telescopic boom pads
Appearance of the mechanical parts, hydraulic hoses and wiring			Suspension, driver seat rails
Attachment device : nuts and bolts and hydraulic fitting		<b>Diesel circuit</b>	
Operation of the work lighting controls, the light indicators, display load moment indicator		Condensation	
Diesel engine operation		Pre-filter	
State of anti-slip parts		Filter	
State of tires and inflation pressure		<b>Air filter (system)</b>	
Wheel nut torque		Remove the dust	
Chain wear		Primary air filter	
<b>Internal combustion engine (See manufacturer's guide)</b>		Secondary air filter	
Oil		<b>Cooling system</b>	
Oil filter cartridge		Coolant	
Belt tension	(1)  (2)	Hoses and collars	
Engine mounting		Radiator slats	
Glow plugs		Cleanliness of the radiator's protection grill	
<b>Travel axles (See manufacturer's guide)</b>		<b>Hydraulic circuit</b>	
Front axle : Reducer + differential + transfer case on front axle + pivots		Hydraulic oil	
Rear axle : Reducer + differential + pivots		Attachment hydraulic oil	
Epicyclic gears		Transmission hydraulic filter	
<b>Battery</b>		Pressures	
Level			
Date : Number of hours : Intervenor : HAULOTTE Services® contract number : Intervention sheet number : Signature :		<b>Comments</b>	

(1) : For machines fitted with : Engine PERKINS 1104D44T.  
 (2) : For machines fitted with : Engine PERKINS 854E-34TA.

# H - Lubrication and maintenance

4500 h service			
Area	Type of intervention	Area	Type of intervention
<b>General checks</b>		<b>Lubrication</b>	
Windscreen washer fluid		Cylinder pins	
Oil, water, fuel leaks		Boom bottom shaft	
Boom extension chain tension		Telescopic boom pads	
Appearance of the mechanical parts, hydraulic hoses and wiring		Suspension, driver seat rails	
Attachment device : nuts and bolts and hydraulic fitting		<b>Diesel circuit</b>	
Operation of the work lighting controls, the light indicators, display load moment indicator		Condensation	
Diesel engine operation		Pre-filter	
State of anti-slip parts		Filter	
State of tires and inflation pressure		<b>Air filter (system)</b>	
Wheel nut torque		Remove the dust	
<b>Internal combustion engine (See manufacturer's guide)</b>		Primary air filter	
Oil		Secondary air filter	
Oil filter cartridge		<b>Cooling system</b>	
Belt tension		Coolant	
Engine crankcase breather	 (1)	Hoses and collars	
<b>Travel axles (See manufacturer's guide)</b>		Radiator slats	
Front axle : Reducer + differential + transfer case on front axle + pivots		Cleanliness of the radiator's protection grill	
Rear axle : Reducer + differential + pivots		<b>Battery</b>	
Epicyclic gears		Level	
<b>Hydraulic circuit</b>			
Hydraulic oil			
Date : Number of hours : Intervenor : HAULOTTE Services® contract number : Intervention sheet number : Signature :		Comments	

(1) : For machines fitted with : Engine PERKINS 854E-34TA.

A  
B  
C  
D  
E  
F  
G

H

I

# H - Lubrication and maintenance

5000 h service			
Area		Type of intervention	Type of intervention
<b>General checks</b>			<b>Lubrication</b>
Windscreen washer fluid			Cylinder pins
Oil, water, fuel leaks			Boom bottom shaft
Boom extension chain tension			Telescopic boom pads
Appearance of the mechanical parts, hydraulic hoses and wiring			Suspension, driver seat rails
Attachment device : nuts and bolts and hydraulic fitting			<b>Diesel circuit</b>
Operation of the work lighting controls, the light indicators, display load moment indicator			Condensation
Diesel engine operation			Pre-filter
State of anti-slip parts			Filter
State of tires and inflation pressure			<b>Air filter (system)</b>
Wheel nut torque			Remove the dust
Chain wear			Primary air filter
<b>Internal combustion engine (See manufacturer's guide)</b>			Secondary air filter
Oil			<b>Cooling system</b>
Oil filter cartridge			Coolant
Belt tension	(1)		Hoses and collars
Engine mounting			Radiator slats
Glow plugs			Cleanliness of the radiator's protection grill
<b>Travel axles (See manufacturer's guide)</b>			<b>Hydraulic circuit</b>
Front axle : Reducer + differential + transfer case on front axle + pivots			Hydraulic oil
Rear axle : Reducer + differential + pivots			Attachment hydraulic oil
Epicyclic gears			Transmission hydraulic filter
<b>Battery</b>			
Level			
Date : Number of hours : Intervenor : HAULOTTE Services® contract number : Intervention sheet number : Signature :		<b>Comments</b>	

(1) : For machines fitted with : Engine KOHLER KDI 3404 TCR.

# H - Lubrication and maintenance

5500 h service			
Area	Type of intervention	Area	Type of intervention
<b>General checks</b>		<b>Lubrication</b>	
Windscreen washer fluid		Cylinder pins	
Oil, water, fuel leaks		Boom bottom shaft	
Boom extension chain tension		Telescopic boom pads	
Appearance of the mechanical parts, hydraulic hoses and wiring		Suspension, driver seat rails	
Attachment device : nuts and bolts and hydraulic fitting		<b>Diesel circuit</b>	
Operation of the work lighting controls, the light indicators, display load moment indicator		Condensation	
Diesel engine operation		Pre-filter	
State of anti-slip parts		Filter	
State of tires and inflation pressure		<b>Air filter (system)</b>	
Wheel nut torque		Remove the dust	
<b>Internal combustion engine (See manufacturer's guide)</b>		Primary air filter	
Oil		Secondary air filter	
Oil filter cartridge		<b>Cooling system</b>	
Belt tension		Coolant	
<b>Travel axles (See manufacturer's guide)</b>		Hoses and collars	
Front axle : Reducer + differential + transfer case on front axle + pivots		Radiator slats	
Rear axle : Reducer + differential + pivots		Cleanliness of the radiator's protection grill	
Epicyclic gears		<b>Battery</b>	
<b>Hydraulic circuit</b>		Level	
Hydraulic oil			
Date : Number of hours : Intervenor : HAULOTTE Services® contract number : Intervention sheet number : Signature :		Comments	

# H - Lubrication and maintenance

6000 h service			
Area	Type of intervention	Area	Type of intervention
<b>General checks</b>		<b>Battery</b>	
Windscreen washer fluid		Level	
Oil, water, fuel leaks		<b>Lubrication</b>	
Boom extension chain tension		Cylinder pins	
Appearance of the mechanical parts, hydraulic hoses and wiring		Boom bottom shaft	
Attachment device : nuts and bolts and hydraulic fitting		Telescopic boom pads	
Operation of the work lighting controls, the light indicators, display load moment indicator		Suspension, driver seat rails	
Diesel engine operation		<b>Diesel circuit</b>	
State of anti-slip parts		Condensation	
State of tires and inflation pressure		Pre-filter	
Wheel nut torque		Filter	
Chain wear		<b>Air filter (system)</b>	
<b>Internal combustion engine (See manufacturer's guide)</b>		Remove the dust	
Oil		Primary air filter	
Oil filter cartridge		Secondary air filter	
Diesel particulate filter	 (1)	<b>Cooling system</b>	
Alternator belt	 (1)	Coolant	(1)  (2) (3)
Engine crankcase breather	 (1)	Hoses and collars	
Belt tension	 (2)	Radiator slats	
Engine mounting		Cleanliness of the radiator's protection grill	
Glow plugs		<b>Hydraulic circuit</b>	
<b>Travel axles (See manufacturer's guide)</b>		Hydraulic oil	
Front axle : Reducer + differential + transfer case on front axle + pivots		Attachment hydraulic oil	
Rear axle : Reducer + differential + pivots		Transmission hydraulic filter	
Epicyclic gears		Pressures	
<b>Date :</b> <b>Number of hours :</b> <b>Intervenor :</b> <b>HAULOTTE Services® contract number :</b> <b>Intervention sheet number :</b> <b>Signature :</b>		<b>Comments</b>	

(1) : For machines fitted with : Engine PERKINS 854E-34TA.  
(2) : For machines fitted with : Engine PERKINS 1104D44T.  
(3) : For machines fitted with : Engine KOHLER KDI 3404 TCR.

# H - Lubrication and maintenance

6500 h service			
Area	Type of intervention	Area	Type of intervention
<b>General checks</b>		<b>Lubrication</b>	
Windscreen washer fluid		Cylinder pins	
Oil, water, fuel leaks		Boom bottom shaft	
Boom extension chain tension		Telescopic boom pads	
Appearance of the mechanical parts, hydraulic hoses and wiring		Suspension, driver seat rails	
Attachment device : nuts and bolts and hydraulic fitting		<b>Diesel circuit</b>	
Operation of the work lighting controls, the light indicators, display load moment indicator		Condensation	
Diesel engine operation		Pre-filter	
State of anti-slip parts		Filter	
State of tires and inflation pressure		<b>Air filter (system)</b>	
Wheel nut torque		Remove the dust	
<b>Internal combustion engine (See manufacturer's guide)</b>		Primary air filter	
Oil		Secondary air filter	
Oil filter cartridge		<b>Cooling system</b>	
Belt tension		Coolant	
<b>Travel axles (See manufacturer's guide)</b>		Hoses and collars	
Front axle : Reducer + differential + transfer case on front axle + pivots		Radiator slats	
Rear axle : Reducer + differential + pivots		Cleanliness of the radiator's protection grill	
Epicyclic gears		<b>Battery</b>	
<b>Hydraulic circuit</b>		Level	
Hydraulic oil			
Date : Number of hours : Intervenor : HAULOTTE Services® contract number : Intervention sheet number : Signature :		Comments	

A  
B  
C  
D  
E  
F  
G  
H  
I

# H - Lubrication and maintenance

7000 h service			
Area	Type of intervention	Area	Type of intervention
<b>General checks</b>		<b>Lubrication</b>	
Windscreen washer fluid		Cylinder pins	
Oil, water, fuel leaks		Boom bottom shaft	
Boom extension chain tension		Telescopic boom pads	
Appearance of the mechanical parts, hydraulic hoses and wiring		Suspension, driver seat rails	
Attachment device : nuts and bolts and hydraulic fitting		<b>Diesel circuit</b>	
Operation of the work lighting controls, the light indicators, display load moment indicator		Condensation	
Diesel engine operation		Pre-filter	
State of anti-slip parts		Filter	
State of tires and inflation pressure		<b>Air filter (system)</b>	
Wheel nut torque		Remove the dust	
Chain wear		Primary air filter	
<b>Internal combustion engine (See manufacturer's guide)</b>		Secondary air filter	
Oil		<b>Cooling system</b>	
Oil filter cartridge		Coolant	
Belt tension		Hoses and collars	
Engine mounting		Radiator slats	
Glow plugs		Cleanliness of the radiator's protection grill	
<b>Travel axles (See manufacturer's guide)</b>		<b>Hydraulic circuit</b>	
Front axle : Reducer + differential + transfer case on front axle + pivots		Hydraulic oil	
Rear axle : Reducer + differential + pivots		Attachment hydraulic oil	
Epicyclic gears		Transmission hydraulic filter	
<b>Battery</b>			
Level			
Date : Number of hours : Intervenor : HAULOTTE Services® contract number : Intervention sheet number : Signature :		Comments	

# H - Lubrication and maintenance

7500 h service			
Area	Type of intervention	Area	Type of intervention
<b>General checks</b>		<b>Lubrication</b>	
Windscreen washer fluid		Cylinder pins	
Oil, water, fuel leaks		Boom bottom shaft	
Boom extension chain tension		Telescopic boom pads	
Appearance of the mechanical parts, hydraulic hoses and wiring		Suspension, driver seat rails	
Attachment device : nuts and bolts and hydraulic fitting		<b>Diesel circuit</b>	
Operation of the work lighting controls, the light indicators, display load moment indicator		Condensation	
Diesel engine operation		Pre-filter	
State of anti-slip parts		Filter	
State of tires and inflation pressure		<b>Air filter (system)</b>	
Wheel nut torque		Remove the dust	
<b>Internal combustion engine (See manufacturer's guide)</b>		Primary air filter	
Oil		Secondary air filter	
Oil filter cartridge		<b>Cooling system</b>	
Belt tension		Coolant	
Engine crankcase breather	 (1)	Hoses and collars	
<b>Travel axles (See manufacturer's guide)</b>		Radiator slats	
Front axle : Reducer + differential + transfer case on front axle + pivots		Cleanliness of the radiator's protection grill	
Rear axle : Reducer + differential + pivots		<b>Battery</b>	
Epicyclic gears		Level	
<b>Hydraulic circuit</b>			
Hydraulic oil			
Date : Number of hours : Intervenor : HAULOTTE Services® contract number : Intervention sheet number : Signature :		Comments	

(1) : For machines fitted with : Engine PERKINS 854E-34TA.



# H - Lubrication and maintenance

8000 h service			
Area	Type of intervention	Area	Type of intervention
<b>General checks</b>		<b>Lubrication</b>	
Windscreen washer fluid		Cylinder pins	
Oil, water, fuel leaks		Boom bottom shaft	
Boom extension chain tension		Telescopic boom pads	
Appearance of the mechanical parts, hydraulic hoses and wiring		Suspension, driver seat rails	
Attachment device : nuts and bolts and hydraulic fitting		<b>Diesel circuit</b>	
Operation of the work lighting controls, the light indicators, display load moment indicator		Condensation	
Diesel engine operation		Pre-filter	
State of anti-slip parts		Filter	
State of tires and inflation pressure		<b>Air filter (system)</b>	
Wheel nut torque		Remove the dust	
Chain wear		Primary air filter	
<b>Internal combustion engine (See manufacturer's guide)</b>		Secondary air filter	
Oil		<b>Cooling system</b>	
Oil filter cartridge		Coolant	
Belt tension	(1)  (2)	Hoses and collars	
Engine mounting		Radiator slats	
Glow plugs		Cleanliness of the radiator's protection grill	
<b>Travel axles (See manufacturer's guide)</b>		<b>Hydraulic circuit</b>	
Front axle : Reducer + differential + transfer case on front axle + pivots		Hydraulic oil	
Rear axle : Reducer + differential + pivots		Attachment hydraulic oil	
Epicyclic gears		Transmission hydraulic filter	
<b>Battery</b>		Pressures	
Level			
Date : Number of hours : Intervenor : HAULOTTE Services® contract number : Intervention sheet number : Signature :		<b>Comments</b>	

(1) : For machines fitted with : Engine PERKINS 1104D44T.

(2) : For machines fitted with : Engine PERKINS 854E-34TA.

# H - Lubrication and maintenance

8500 h service			
Area	Type of intervention	Area	Type of intervention
<b>General checks</b>		<b>Lubrication</b>	
Windscreen washer fluid		Cylinder pins	
Oil, water, fuel leaks		Boom bottom shaft	
Boom extension chain tension		Telescopic boom pads	
Appearance of the mechanical parts, hydraulic hoses and wiring		Suspension, driver seat rails	
Attachment device : nuts and bolts and hydraulic fitting		<b>Diesel circuit</b>	
Operation of the work lighting controls, the light indicators, display load moment indicator		Condensation	
Diesel engine operation		Pre-filter	
State of anti-slip parts		Filter	
State of tires and inflation pressure		<b>Air filter (system)</b>	
Wheel nut torque		Remove the dust	
<b>Internal combustion engine (See manufacturer's guide)</b>		Primary air filter	
Oil		Secondary air filter	
Oil filter cartridge		<b>Cooling system</b>	
Belt tension		Coolant	
<b>Travel axles (See manufacturer's guide)</b>		Hoses and collars	
Front axle : Reducer + differential + transfer case on front axle + pivots		Radiator slats	
Rear axle : Reducer + differential + pivots		Cleanliness of the radiator's protection grill	
Epicyclic gears		<b>Battery</b>	
<b>Hydraulic circuit</b>		Level	
Hydraulic oil			
Date : Number of hours : Intervenor : HAULOTTE Services® contract number : Intervention sheet number : Signature :		Comments	

A  
B  
C  
D  
E  
F  
G  
H  
I

# H - Lubrication and maintenance

9000 h service			
Area	Type of intervention	Area	Type of intervention
<b>General checks</b>		<b>Battery</b>	
Windscreen washer fluid		Level	
Oil, water, fuel leaks		<b>Lubrication</b>	
Boom extension chain tension		Cylinder pins	
Appearance of the mechanical parts, hydraulic hoses and wiring		Boom bottom shaft	
Attachment device : nuts and bolts and hydraulic fitting		Telescopic boom pads	
Operation of the work lighting controls, the light indicators, display load moment indicator		Suspension, driver seat rails	
Diesel engine operation		<b>Diesel circuit</b>	
State of anti-slip parts		Condensation	
State of tires and inflation pressure		Pre-filter	
Wheel nut torque		Filter	
Chain wear		<b>Air filter (system)</b>	
<b>Internal combustion engine (See manufacturer's guide)</b>		Remove the dust	
Oil		Primary air filter	
Oil filter cartridge		Secondary air filter	
Diesel particulate filter	 (1)	<b>Cooling system</b>	
Alternator belt	 (1)	Coolant	 (1) (2) (3)
Engine crankcase breather	 (1)	Hoses and collars	
Belt tension	 (2)	Radiator slats	
Engine mounting		Cleanliness of the radiator's protection grill	
Glow plugs		<b>Hydraulic circuit</b>	
<b>Travel axles (See manufacturer's guide)</b>		Hydraulic oil	
Front axle : Reducer + differential + transfer case on front axle + pivots		Attachment hydraulic oil	
Rear axle : Reducer + differential + pivots		Transmission hydraulic filter	
Epicyclic gears			
<b>Date :</b> <b>Number of hours :</b> <b>Intervenor :</b> <b>HAULOTTE Services® contract number :</b> <b>Intervention sheet number :</b> <b>Signature :</b>		<b>Comments</b>	

(1) : For machines fitted with : Engine PERKINS 854E-34TA.  
(2) : For machines fitted with : Engine PERKINS 1104D44T.  
(3) : For machines fitted with : Engine KOHLER KDI 3404 TCR.

# H - Lubrication and maintenance

9500 h service			
Area	Type of intervention	Area	Type of intervention
<b>General checks</b>		<b>Lubrication</b>	
Windscreen washer fluid		Cylinder pins	
Oil, water, fuel leaks		Boom bottom shaft	
Boom extension chain tension		Telescopic boom pads	
Appearance of the mechanical parts, hydraulic hoses and wiring		Suspension, driver seat rails	
Attachment device : nuts and bolts and hydraulic fitting		<b>Diesel circuit</b>	
Operation of the work lighting controls, the light indicators, display load moment indicator		Condensation	
Diesel engine operation		Pre-filter	
State of anti-slip parts		Filter	
State of tires and inflation pressure		<b>Air filter (system)</b>	
Wheel nut torque		Remove the dust	
<b>Internal combustion engine (See manufacturer's guide)</b>		Primary air filter	
Oil		Secondary air filter	
Oil filter cartridge		<b>Cooling system</b>	
Belt tension		Coolant	
<b>Travel axles (See manufacturer's guide)</b>		Hoses and collars	
Front axle : Reducer + differential + transfer case on front axle + pivots		Radiator slats	
Rear axle : Reducer + differential + pivots		Cleanliness of the radiator's protection grill	
Epicyclic gears		<b>Battery</b>	
<b>Hydraulic circuit</b>		Level	
Hydraulic oil			
Date : Number of hours : Intervenor : HAULOTTE Services® contract number : Intervention sheet number : Signature :		Comments	

A  
B  
C  
D  
E  
F  
G  
H  
I

# H - Lubrication and maintenance

10000 h service			
Area		Type of intervention	Type of intervention
<b>General checks</b>			<b>Lubrication</b>
Windscreen washer fluid			Cylinder pins
Oil, water, fuel leaks			Boom bottom shaft
Boom extension chain tension			Telescopic boom pads
Appearance of the mechanical parts, hydraulic hoses and wiring			Suspension, driver seat rails
Attachment device : nuts and bolts and hydraulic fitting		<b>Diesel circuit</b>	
Operation of the work lighting controls, the light indicators, display load moment indicator		Condensation	
Diesel engine operation		Pre-filter	
State of anti-slip parts		Filter	
State of tires and inflation pressure		<b>Air filter (system)</b>	
Wheel nut torque		Remove the dust	
Chain wear		Primary air filter	
<b>Internal combustion engine (See manufacturer's guide)</b>		Secondary air filter	
Oil		<b>Cooling system</b>	
Oil filter cartridge		Coolant	
Belt tension	(1) (3)  (2)	Hoses and collars	
Engine mounting		Radiator slats	
Glow plugs		Cleanliness of the radiator's protection grill	
<b>Travel axles (See manufacturer's guide)</b>		<b>Hydraulic circuit</b>	
Front axle : Reducer + differential + transfer case on front axle + pivots		Hydraulic oil	
Rear axle : Reducer + differential + pivots		Attachment hydraulic oil	
Epicyclic gears		Transmission hydraulic filter	
<b>Battery</b>		Pressures	
Level			
<b>Date :</b> <b>Number of hours :</b> <b>Intervenor :</b> <b>HAULOTTE Services® contract number :</b> <b>Intervention sheet number :</b> <b>Signature :</b>		<b>Comments</b>	

- (1) : For machines fitted with : Engine PERKINS 1104D44T.
- (2) : For machines fitted with : Engine PERKINS 854E-34TA.
- (3) : For machines fitted with : Engine KOHLER KDI 3404 TCR.

# H - Lubrication and maintenance

10500 h service			
Area	Type of intervention	Area	Type of intervention
<b>General checks</b>		<b>Lubrication</b>	
Windscreen washer fluid		Cylinder pins	
Oil, water, fuel leaks		Boom bottom shaft	
Boom extension chain tension		Telescopic boom pads	
Appearance of the mechanical parts, hydraulic hoses and wiring		Suspension, driver seat rails	
Attachment device : nuts and bolts and hydraulic fitting		<b>Diesel circuit</b>	
Operation of the work lighting controls, the light indicators, display load moment indicator		Condensation	
Diesel engine operation		Pre-filter	
State of anti-slip parts		Filter	
State of tires and inflation pressure		<b>Air filter (system)</b>	
Wheel nut torque		Remove the dust	
<b>Internal combustion engine (See manufacturer's guide)</b>		Primary air filter	
Oil		Secondary air filter	
Oil filter cartridge		<b>Cooling system</b>	
Belt tension		Coolant	
Engine crankcase breather	 (1)	Hoses and collars	
<b>Travel axles (See manufacturer's guide)</b>		Radiator slats	
Front axle : Reducer + differential + transfer case on front axle + pivots		Cleanliness of the radiator's protection grill	
Rear axle : Reducer + differential + pivots		<b>Battery</b>	
Epicyclic gears		Level	
<b>Hydraulic circuit</b>			
Hydraulic oil			
Date : Number of hours : Intervenor : HAULOTTE Services® contract number : Intervention sheet number : Signature :		Comments	

(1) : For machines fitted with : Engine PERKINS 854E-34TA.

A  
B  
C  
D  
E  
F  
G

H

I

# H - Lubrication and maintenance

11000 h service			
Area	Type of intervention	Area	Type of intervention
<b>General checks</b>		<b>Lubrication</b>	
Windscreen washer fluid		Cylinder pins	
Oil, water, fuel leaks		Boom bottom shaft	
Boom extension chain tension		Telescopic boom pads	
Appearance of the mechanical parts, hydraulic hoses and wiring		Suspension, driver seat rails	
Attachment device : nuts and bolts and hydraulic fitting		<b>Diesel circuit</b>	
Operation of the work lighting controls, the light indicators, display load moment indicator		Condensation	
Diesel engine operation		Pre-filter	
State of anti-slip parts		Filter	
State of tires and inflation pressure		<b>Air filter (system)</b>	
Wheel nut torque		Remove the dust	
Chain wear		Primary air filter	
<b>Internal combustion engine (See manufacturer's guide)</b>		Secondary air filter	
Oil		<b>Cooling system</b>	
Oil filter cartridge		Coolant	
Belt tension		Hoses and collars	
Engine mounting		Radiator slats	
Glow plugs		Cleanliness of the radiator's protection grill	
<b>Travel axles (See manufacturer's guide)</b>		<b>Hydraulic circuit</b>	
Front axle : Reducer + differential + transfer case on front axle + pivots		Hydraulic oil	
Rear axle : Reducer + differential + pivots		Attachment hydraulic oil	
Epicyclic gears		Transmission hydraulic filter	
<b>Battery</b>			
Level			
Date : Number of hours : Intervenor : HAULOTTE Services® contract number : Intervention sheet number : Signature :		<b>Comments</b>	

# H - Lubrication and maintenance

11500 h service			
Area	Type of intervention	Area	Type of intervention
<b>General checks</b>		<b>Lubrication</b>	
Windscreen washer fluid		Cylinder pins	
Oil, water, fuel leaks		Boom bottom shaft	
Boom extension chain tension		Telescopic boom pads	
Appearance of the mechanical parts, hydraulic hoses and wiring		Suspension, driver seat rails	
Attachment device : nuts and bolts and hydraulic fitting		<b>Diesel circuit</b>	
Operation of the work lighting controls, the light indicators, display load moment indicator		Condensation	
Diesel engine operation		Pre-filter	
State of anti-slip parts		Filter	
State of tires and inflation pressure		<b>Air filter (system)</b>	
Wheel nut torque		Remove the dust	
<b>Internal combustion engine (See manufacturer's guide)</b>		Primary air filter	
Oil		Secondary air filter	
Oil filter cartridge		<b>Cooling system</b>	
Belt tension		Coolant	
<b>Travel axles (See manufacturer's guide)</b>		Hoses and collars	
Front axle : Reducer + differential + transfer case on front axle + pivots		Radiator slats	
Rear axle : Reducer + differential + pivots		Cleanliness of the radiator's protection grill	
Epicyclic gears		<b>Battery</b>	
<b>Hydraulic circuit</b>		Level	
Hydraulic oil			
Date : Number of hours : Intervenor : HAULOTTE Services® contract number : Intervention sheet number : Signature :		Comments	

A  
B  
C  
D  
E  
F  
G  
H  
I

# H - Lubrication and maintenance

12000 h service			
Area	Type of intervention	Area	Type of intervention
<b>General checks</b>		<b>Battery</b>	
Windscreen washer fluid		Level	
Oil, water, fuel leaks		<b>Lubrication</b>	
Boom extension chain tension		Cylinder pins	
Appearance of the mechanical parts, hydraulic hoses and wiring		Boom bottom shaft	
Attachment device : nuts and bolts and hydraulic fitting		Telescopic boom pads	
Operation of the work lighting controls, the light indicators, display load moment indicator		Suspension, driver seat rails	
Diesel engine operation		<b>Diesel circuit</b>	
State of anti-slip parts		Condensation	
State of tires and inflation pressure		Pre-filter	
Wheel nut torque		Filter	
Chain wear		<b>Air filter (system)</b>	
<b>Internal combustion engine (See manufacturer's guide)</b>		Remove the dust	
Oil		Primary air filter	
Oil filter cartridge		Secondary air filter	
Diesel particulate filter	 (1)	<b>Cooling system</b>	
Alternator belt	 (1)	Coolant	 (1) (2) (3)
Engine crankcase breather	 (1)	Hoses and collars	
Belt tension	 (2)	Radiator slats	
Engine mounting		Cleanliness of the radiator's protection grill	
Glow plugs		<b>Hydraulic circuit</b>	
<b>Travel axles (See manufacturer's guide)</b>		Hydraulic oil	
Front axle : Reducer + differential + transfer case on front axle + pivots		Attachment hydraulic oil	
Rear axle : Reducer + differential + pivots		Transmission hydraulic filter	
Epicyclic gears		Pressures	
<b>Date :</b> <b>Number of hours :</b> <b>Intervenor :</b> <b>HAULOTTE Services® contract number :</b> <b>Intervention sheet number :</b> <b>Signature :</b>		<b>Comments</b>	

(1) : For machines fitted with : Engine PERKINS 854E-34TA.  
 (2) : For machines fitted with : Engine PERKINS 1104D44T.  
 (3) : For machines fitted with : Engine KOHLER KDI 3404 TCR.

# H - Lubrication and maintenance

## 7 - General points

### 7.1 - MECHANICAL

#### 7.1.1 - Bolts and Tightening torques

- Bolts that become damaged and need to be replaced, must be replaced with bolts of identical specification : Type, Length, Diameter, Class .
- Tighten to the torque indicated when reassembling.

#### 7.1.2 - Pins and bearings

Except maintenance schedule, check pins and bearings in the following cases :

- Abnormal noise during the movements of the structure.
- Observance of excessive amounts of foreign material around the bearing extremities during the daily visual inspections.
- Poor or no maintenance.

Replace slew ring in the following cases :

- Deformations, fatigue failure of the bearings and/or the pins.
- Presence of excessive clearance between the pin and housing(> at 0,5 mm).
- Presence of deformations, cracks or breakage of the bearings and/or the pins.
- Presence of scoring on the surface of the bearing.
- If there is excessive friction.

When reassembling bearings and pins ensure that :

- Lightly lubricate the housing into which the bearing is to be installed.
- Insert the bearing using a bearing drift, preferably out of mild steel.
- The bearing, the bearing drift and the bearing housing must be correctly aligned during the assembly process.

# H - Lubrication and maintenance

- The recommended values for the bearing drift are given on the diagram below :

### Recommended Values

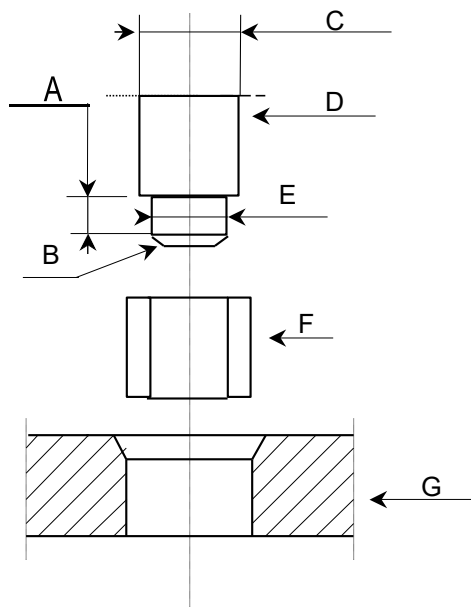

Marking	Description
A	At least 0,5 times the nominal diameter
B	Make a chamfer
C	Nominal diameter of the bearing - 0,2 / - 0,3 mm
D	Bearing drift
E	Diameter of the bearing guide - 0,20 / - 0,25 mm
F	Bearing
G	Housing

- After inserting the bearing, lubricate and fit the pin.

# H - Lubrication and maintenance

## 7.1.3 - Bearings

Action on bearings needs to be taken outside the normal maintenance schedule if the following occurs :

- Abnormal noise during the movements of the structure.
- Machine not use for a period of 6 months or more.
- Environment of storage and specific uses(Strong moisture and salinity of the air).

Checking procedure :

- After disassembling the affected pivot, protect the bearing from external pollutants and potential damage.
- Clean the bearing with a suitable solvent.
- Replace the bearing in the following cases :
  - Presence of abrasions in the bearing housing and/or inside the bearing itself.
  - Presence of abrasion, wear, oxidation, deformations of the balls (or rollers) and the ring rollers.
- Reassembly of the bearing/pivot :
  - Clean the bearing housing or pin in order to remove all the foreign objects/abrasions.
  - Lightly lubricate the bearing housing and/or pin.
  - Lightly lubricate the outer ring of the bearing.
  - Fit a bearing in a boring, take support on the external ring of the bearing.
  - Fit a bearing on a pin, take support on the interior ring of the bearing.

A

B

C

D

E

F

G

H

I

# H - Lubrication and maintenance

## 7.2 - HYDRAULICS

### 7.2.1 - Replacing damaged of hoses

Replace hoses in the following circumstances :

- Tears in the outer casing.
- Cracks in the outer casing.
- Apparent shielding.
- Visible leak in the hose.
- Damage to the outer casing caused by chemical reaction from a foreign source.



To protect personal safety, observe the following conditions when disassembling or reassembling components :

- Stow and park the machine on level cleared ground(The machine should not be tilted. The boom at horizontal position).
- Stow the machine completely.
- Place barriers around the perimeter of the work area (risk area = maximum height of the machine).
- Locate the faulty hose/s and their end connection points, to ensure proper machine operation after intervention.
- Identify and memorise the hose path of the hose to be replaced.



Use an oil collection pan to avoid polluting the environment.

*N.B.:-Slowly undo the hose end fitting to allow the residual hydraulic pressure to dissipate.*



- After hose removal, plug the the hose ends and components the ports from which the hose was removed, to avoid polluting the hydraulic system.
- Check the cleanliness of the hoses and hydraulic components (no metal cutting, rubber, plastic, ...).
- If necessary, drain and clean the whole system (tank included).
- Tighten to the torque indicated when reassembling.

Tightening torque table

Description	Torque (JIC)	Torque (ORFS)
Hose 1/4" (diameter 6mm)	1,5 daN.m(11,08 lbf.ft)	2,6 daN.m(19,22 lbf.ft)
Hose 3/8" (diameter 10mm)	3,5 daN.m(25,86 lbf.ft)	4,2 daN.m(31,04 lbf.ft)
Hose 1/2" (diameter 12mm)	5 daN.m(36,95 lbf.ft)	5,7 daN.m(42,12 lbf.ft)
Hose 5/8" (diameter 16mm)	8 daN.m(59,12 lbf.ft)	8,5 daN.m(62,82 lbf.ft)
Hose 3/4" (diameter 19)	10 daN.m(73,91 lbf.ft)	12,2 daN.m(90,17 lbf.ft)



- Place the machine in its operating configuration.
- To purge the hydraulic system, operate the function/s on the machine that correspond to the hose/s that has/have been replaced, a few times.
- Check the oil level in the hydraulic oil tank.
- Check the pressure.

# H - Lubrication and maintenance

## 7.2.2 - Evaluation of leaks on hydraulic cylinders

These measures must be taken each time an anomaly has been detected in the hydraulic cylinder during daily inspection and periodic maintenance checks.

Generic Control :

- Position a load equal to the rated capacity on the cage (or platform).
- Raise the loaded attachment using the ground control box. To activate the cylinder to be tested, proceed as follows :
  - Boom lift cylinder : Raise the boom approximately half way to its maximum angle.
  - Telescoping cylinder : Lift the boom to its maximum angle and telescope approximately 50 cm.
  - Crowding/Discharging cylinder : Place a load on the forks and put them in a horizontal position. The drift of the forks must be less than 2 ° after 15 mn.
- Measure the distance between a reference point on the attachment and the ground.
- Leave the machine in this condition for 15 mn (minutes).
- Check the distance between the reference point on the accessory and the ground again.
  - If the difference between two measurements does not exceed 4 cm : the test validates correct operation.
  - If the difference between two measurements exceeds 4 cm, contact HAULOTTE Services® or carry out the additional tests described below.

Control cylinder by cylinder :

- Position a load equal to the rated capacity on the attachment.
- Perform the movement of the concern cylinder to half of its stroke.
- Fix the cylinder with a comparator :
  - Attach the body of the comparator on the cylinder rod.
  - The needle of the comparator must be in contact with the end of the casing of the cylinder.
  - The target is to measure the creep of the cylinder rod.
- If the creep of the cylinder rod is higher than the values indicated in the table below, replace the cylinder.

Type of cylinders	Maximum drift authorised due to an internal leak of the cylinder	
	After 10 mn, creep < 0,5 mm	After 60 mn, creep < 2,5 mm
Loads levelling cylinders and axle locking cylinders	After 10 mn, creep < 0,5 mm	After 60 mn, creep < 2,5 mm
Boom lifting cylinder, telescoping cylinder, compensation cylinder (crowding)	After 10 mn, creep < 1 mm	After 60 mn, creep < 6 mm

# H

## - Lubrication and maintenance

### 7.3 - ELECTRIC

#### 7.3.1 - Replacing damaged cables

- Locate the faulty wire/s and its/their points of connection to ensure continuity of machine operation after the wire is replaced.
- Note the cable path to facilitate reassembly.
- Respect the order (configuration) of origin during the reassembly.

# H - Lubrication and maintenance

## 8 - Every day or every 10 h of operation

### 8.1 - GENERAL CHECKS

- Perform a visual check for any leaks (Check the corresponding reservoir level if leak is detected).
- Check that there are no signs of scratches, tears and warping on the hoses, accessories and work tools.
- Check the attachment devices and the hydraulic connections.
- Check the appearance of the mechanical parts.
- Check the operation of the controls, control indicator lights and other system indicators.
- Check diesel engine operation : Check the colour of the exhaust fumes and locate any abnormal noises.
- Check and clean the radiator's protection grill.
- Check the state of the anti-slip parts (cab access steps) and replace them if necessary.
- Check that the tires are not damaged after the first 10 hours and then after every 100 h of operation.



**Check the tire inflation pressure : 4,5 bar(65,2 psi) minimum (For HAULOTTE® tyres, code : 2326014870) or 5,1 bar(74 psi) (For HAULOTTE® tyres, code : 4000085980 or 2326016330 (Option)).**



**During a pressure check or an inflation operation, always face the end of the tyre; never face the side of the tyre.**

- Check the wheel lug nut torque ( 500Nm) after the first 10 hours and then after every 100 h of operation.
- Lubricate the extension chains regularly according to use.



**Do not allow contact with abrasive materials.**

# H - Lubrication and maintenance

## 8.2 - LOAD MOMENT INDICATOR

### 8.2.1 - Test procedure

The load moment indicator's function is to constantly monitoring the stability of the front of the machine. To check that it is functioning correctly, proceed as follows :

- Without any payload on the machine, retract the boom fully and level it.



**Do not raise the boom during this test.**

- Level the chassis.
- Press the TEST button on the anti-tipping system display ( P219 ) for 1 s (  Section C 3.5.10 - Load moment indicator).

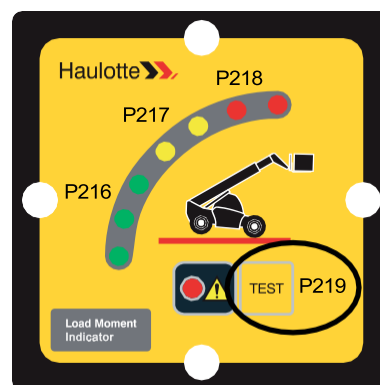

- All of the LEDs should flash and a warning signal should sound. This indicates that the system is working properly.

### 8.2.2 - Checking procedure



**Perform this operation on flat ground, with the chassis level, the wheels aligned and the stabilisers lifted.**

- Lift a known load with the accessory.
- Telescope until load cut-off.
- Check that the results are constant: check that the alphabetical reference (A, B, C, D, E, F) for the boom extension and the area corresponding to the reference on the load capacity table match.



**If the test gives another result, the system will not operate correctly. Reset the anti-tipping system.**

# H - Lubrication and maintenance

## 8.2.3 - Resetting procedure



To perform this operation :

- Raise the stabilisers.
- Place the machine on flat ground.
- Level the machine.
- Align the wheels.
- Retract the telescope section fully.
- Lift the boom to the maximum height.
- Check the temperature of the axle: the temperature of the axle must be between -20 °C(-4 °F) and 60 °C(140 °F) .



The procedure must be carried out without any accessories or load.



If these conditions are not satisfied, the resetting procedure may be distorted and cause the weighing system to be offset.

- Press on the TEST (P219) button for 6 s until you hear the beep to start the resetting procedure.
- The procedure is executed.



If a malfunction occurs, contact HAULOTTE Services®.

## 8.3 - DIESEL CIRCUIT

- To prevent condensation from forming, fill the reservoir every day after work (Capacity : 135 l(35,6 gal US)).
- Drain any condensate and clean the diesel pre-filter.
- To access the diesel pre-filter, open the engine cover. The pre-filter is located under the diesel filter
- Drain the water and dirt by removing the screw situated under the pre-filter (For machines fitted with engine PERKINS 854E-34TA or PERKINS 1104D44T only).
- Refit and tighten the purge screw.

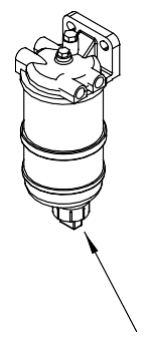

# H - Lubrication and maintenance

## 8.4 - COOLING SYSTEM

- Check the coolant level :
- When the engine is cool, the liquid level must be situated between the min. and max. marks on the expansion bottle.
- Open the radiator and top up with fluid as necessary.
- Only refill with SHELL ANTIFREEZE -38 °C(-36,4 °F) coolant.



**Do not remove the filling cap when the engine is hot. DANGER OF BURNS!** Loosen the plug to the first notch and let it depressurize, then unscrew the cap completely.

- Check the state of the hoses and that the collars are taut.

## 8.5 - AIR FILTER (SYSTEM)



**Never run the engine without an air cleaner element installed or with a damaged air cleaner element.**



**Do not use air cleaner elements with damaged pleats, gaskets or seals.**



**Dirt entering the engine causes premature wear and damage to engine components. Air cleaner elements help to prevent airborne debris from entering the air inlet.**



**Never service the air cleaner element with the engine running since this will allow dirt to enter the engine.**

- Empty the dust filter :
- Empty the dust evacuation valve ( 1 ) by pressing on the evacuation slot in the direction of the arrow.
- Clean the evacuation slot.
- Clean away any remaining dust by pressing the upper part of the valve.

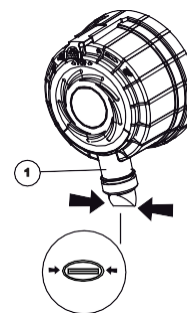

**N.B.-:** If the air cleaner element becomes plugged, the air can split the material of the air cleaner element. Unfiltered air will drastically accelerate internal engine wear.

**N.B.-:** Filter clogging check : Clogging is constantly being monitored via a sensor situated on the filter body. Visually inspect the state of the sensor. If red marking is visible : Clean or replace the filter element even if the cleaning frequency indicated above has not been reached. Clean the inside of the box.

# H - Lubrication and maintenance

- Clean the primary air filter's filter cartridge :
- Remove the cover :
- Pull the trigger situated on the cover ( 1 ).
- Locate the angular position of the cover which should be identical upon reassembly.
- Turn the cover to the right ( 2 ).
- Pull the cover to remove it.
- Turn and pull the outer cartridge.
- Clean the filter cartridge (replace it, at the latest, after every 1000 h of operation or once a year).
- Blow with dry compressed air (with a maximum pressure of 5 bar(72,5 psi)) from the inside of the filter, outwards or
- Unclog by tapping (Only in the event of an emergency). In this case, do not damage the cartridge, or
- Wash it in accordance with the manufacturer's guidelines.
- Check that neither the cartridge filter paper (translucent paper) nor the seal are damaged. Replace it/them if necessary.
- Replace the filter cartridge.
- Refit the cover, checking that the dust evacuation valve is directed downwards.

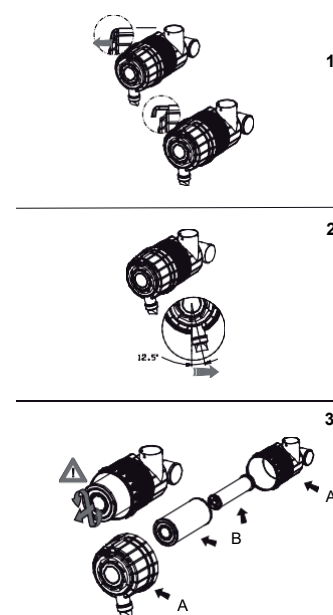

**Check the state of the sealing ring before reassembling the cartridges. Check the state of the filter element with a light source placed inside the cartridge. Change the cartridge if a hole is detected (by a light ray).**



**Never clean the cartridge by hitting it against a hard surface or by using hot flammable liquid.**

# H - Lubrication and maintenance

## 8.6 - INTERNAL COMBUSTION ENGINE



For the following operations, park the machine onto a horizontal surface and turn off the engine.

- Check the oil level :
- Open the motor canopy, remove the oil dip stick; the level must be situated between the two min. and max. marks.
- Top up as necessary via the filler.
- Check the belt tension :
- Correct belt tension is essential to ensure that the alternator, the diesel pump and the water pump work properly and for the service life of the belts themselves.
- A belt in poor condition must be replaced immediately.

## 8.7 - HYDRAULIC CIRCUIT

- Check the oil level :
- Park the machine on a horizontal surface.
- Stow the machine : With the stabilisers raised as far as possible, the fork carriage lowered as far as possible, the boom retracted, the cylinders retracted.
- Check the oil level in the hydraulic oil tank : Hydraulic oil level must be between the min. and max. marks recommended. Top up the oil if necessary.



## 8.8 - AIR-CONDITIONING (OPTION)

Cold weather use :

In order to guarantee the correct operation and for operational efficiency of the air conditioning system it is advisable to turn the compressor on once a week, even for a short period of time, so as to ensure that internal moving parts are lubricated.

Warm up the engine before you turn on the compressor, this the heat produced by the engine to turn the liquid coolant accumulated in the lower part of the compressor circuit to turn into gas. Liquid coolant could damage the compressor.

# H - Lubrication and maintenance

## 9 - After the first 50 hours of operation

### 9.1 - CHAIN TENSION CHECK AND ADJUSTMENT

#### 9.1.1 - Chain tension check

After the first 50 hours and then after every 250 h, check the telescoping chain tension in accordance with the following procedure.

- Fully telescope the boom at horizontal position.
- In the median vertical plane of one of the chains situated under the boom, measure the distance D1 between that chain and the underside of the boom.
- Push the chain upward in the same median vertical plane and measure the distance D2 between that chain and the underside of the boom again.
- Calculate the difference D1- D2. If the value obtained is more than 0,025 m(0 ft08 in), you must retension the chain following the procedure set down in  Section H 9.1.2 - Boom chain tension adjustment.
- Repeat the procedure described above for each of the telescoping chains situated under the boom.



#### 9.1.2 - Boom chain tension adjustment

- The booms are fully extended horizontally following the chain tension check (  Section H 9.1.1 - Chain tension check).
- Retract the telescopic cylinder by approximately 1 m in order to apply tension to the retracted telescopic chains (non-accessible chains) (Inaccessible chains).
- Retighten the upper extended telescoping chains with a torque wrench by applying a 70 N.m torque to each of the locking nuts on the threaded rods situated at the end of each chain yoke.
- Ensure that you distribute the tension between the chains by turning one of the nuts and then the other by successive 1/2 turns..
- Retighten the lower telescope extension chains using 60 N.m torque on each of the fastening nuts of the threaded rods located at the end of each chain yoke (Only on the 17 m(55 ft9 in) arm).
- Ensure that you distribute the tension between the chains by turning one of the nuts and then the other by successive 1/2 turns..
- Finish retracting the boom, all the boom sections should begin moving simultaneously.

# H - Lubrication and maintenance

Diagram

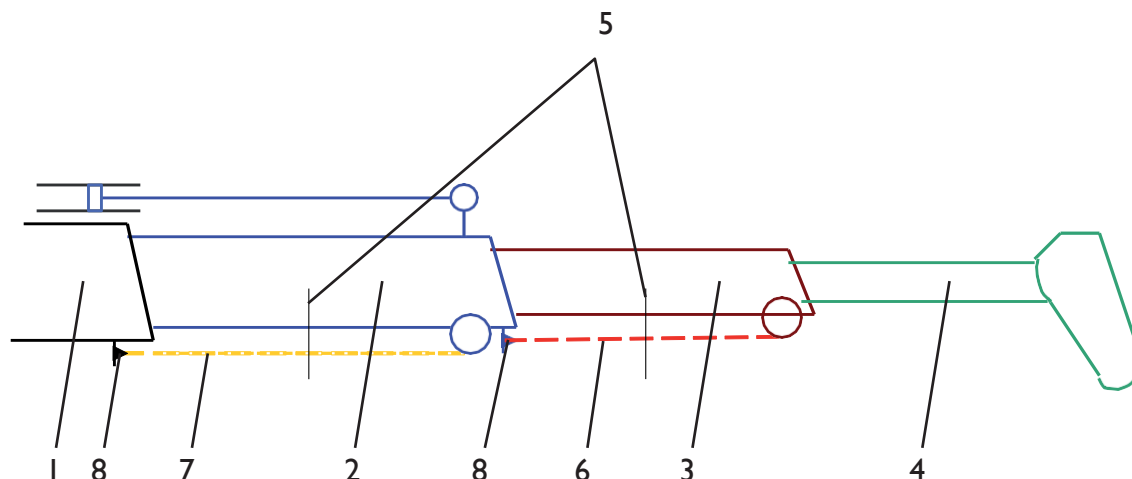

Description of the components

Marking	Description
1	Outer boom
2	Intermediate boom 1
3	Intermediate boom 2
4	Inner boom
5	Mid points
6	Upper extension chains
7	Lower extension chains
8	Chain yokes

## 10 - Every 50 h hours of operation

- Lubricate the cylinder pins equipped with grease points.
- Lubricate the boom bottom shaft.
- Lubricate the sliding area friction pads.
- Check the telescope synchronisation: fully retract the boom and fully extend it. The various elements must come out simultaneously.

 Section H 18.2 - For lubrication operations, refer to the Lubricants and equivalents table for the type of grease to be used.

# H - Lubrication and maintenance

## 11 - Every 100 h hours of operation

### 11.1 - TYRES

Criteria of replacement

Replace the wheels and the tyres if any of the following conditions exist :

- Presence of cracks, damage, deformations or other faults on the hub.
- Damage on the tire :
- Cut or hole >at 3 cm (2 in) in the rubber side wall on the whole tire thickness.
- Blister or pronounce lump on the external and lateral membrane.
- Damaged wheel stud.
- Damage or wear on the side wall to the extent that the reinforcing wire become visible.



**For safety reasons, always use original HAULOTTE® spare parts that are specific to this machine. Refer to the spare parts catalogue.**

- Check that the tires are not damaged.
- Remove the valve rod cap.



**Check the tire inflation pressure : 4,5 bar(65 psi) minimum (For HAULOTTE® tyres, code : 2326014870) or 5,1 bar(74 psi) (For HAULOTTE® tyres, code : 4000085980 or 2326016330 (Option)).**



**During a pressure check or an inflation operation, always face the end of the tyre; never face the side of the tyre**

- Add air if required.
- Replace the valve cap.
- Check the wheel lug nut torque (500 Nm).

***N.B.-:-Perform the first torque check after the first 10 h of operation.***

### 11.2 - DIESEL CIRCUIT

Perform the first diesel pre-filter change after the first 500 hours of operation and then after every 500 h or once a year (  Section H 13.3 - Diesel circuit) (For machines fitted with engine PERKINS 854E-34TA or PERKINS 1104D44T only).

### 11.3 - INTERNAL COMBUSTION ENGINE

Perform the first engine oil drainage and change the filter cartridge after the first 500 hours of operation and then every 500 h (  Section H 13.4 - Internal combustion engine).

# H

## - Lubrication and maintenance

### 11.4 - LUBRICATING THE FRONT AXLE

- Remove the 4 protective caps from each grease point.
- Connect the grease gun.

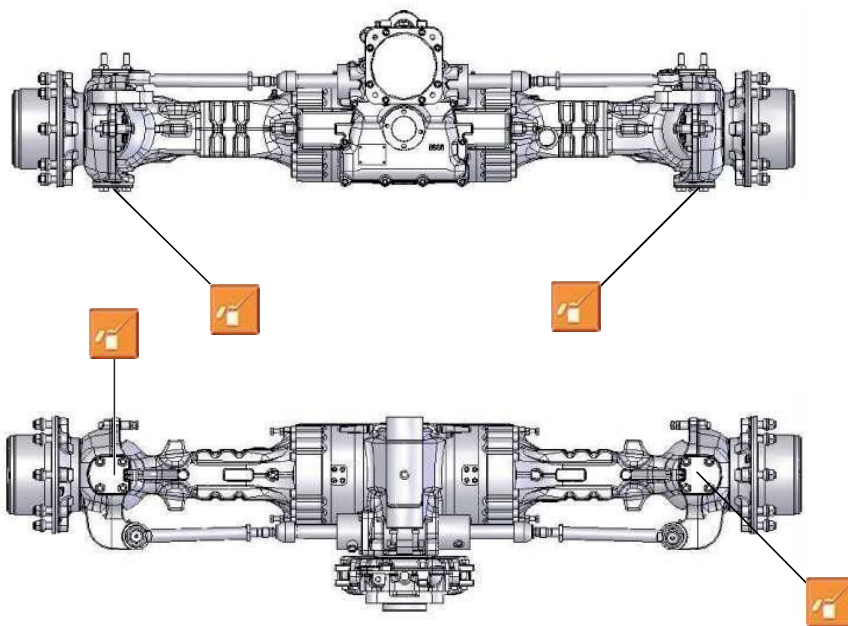

Remove the \*1 protective caps from each grease point.

### 11.5 - LUBRICATING THE REAR AXLES

- Remove the 6 protective caps from each grease point.
- Connect the grease gun.

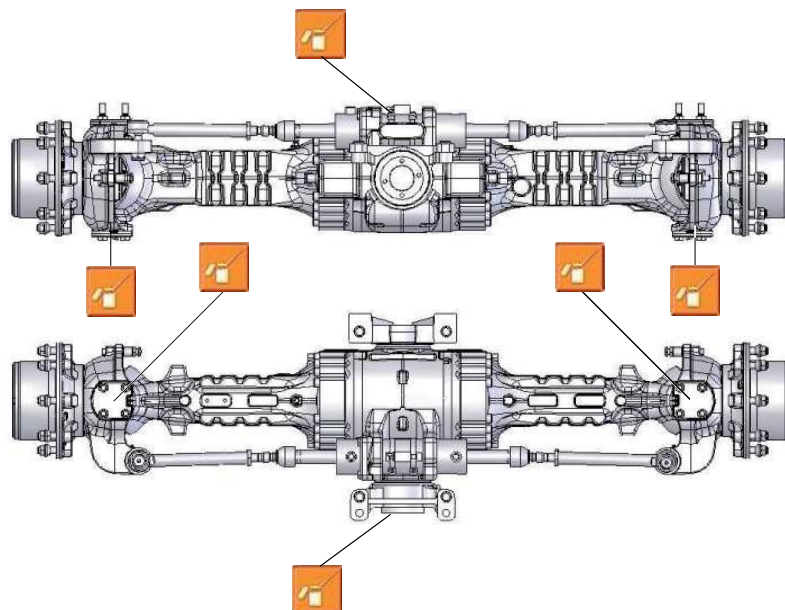

Replace the protective caps once you have lubricated the rear axle.

# H - Lubrication and maintenance

## 11.6 - HYDRAULIC CIRCUIT

Perform the first filter cartridge change after the first 500 hours of operation and then after every 1000 h or once a year (  Section H 14.4 - Hydraulic circuit).

## 11.7 - AIR-CONDITIONING (OPTION)

- Check cleanliness of the condenser. Clean where applicable.

***N.B.***:-Disassemble the protective covers in order to gain access to clean the condenser unit.

- Check the cleanliness of the cab air filter. Clean where applicable.



The system becomes less efficient when the circuit is being discharged. If the air conditioning unit does not work properly, have a qualified and properly equipped person examine it.



All repairs must be carried out by a qualified and authorised person.

A

B

C

D

E

F

G

H

I

# H - Lubrication and maintenance

## 12 - Every 250 h hours of operation

### 12.1 - COOLING SYSTEM

- Clean the radiator slats.



Do not remove the filling cap when the engine is hot. **DANGER OF BURNS!** Loosen the plug to the first notch and let it depressurize, then unscrew the cap completely.

- Clean with a pressurized jet of water or air.



Only clean with water when the engine has cooled down.

### 12.2 - TRAVEL AXLES

Perform the first drainage operation on the front and rear axles and the epicycloidal reducers after the first 250 hours of operation and then every 1000 h (  Section H 15.1 - Travel axles).

*N.B.:-Level check every 500 h (  Section H 13.6 - Travel axles).*

### 12.3 - BATTERY

Battery check :

- Perform the machine shut-down procedure.
- Open the engine cover.
- Wear safety goggles and visually inspect the battery. Check that the terminals are not corroded. Replace the battery if its case is cracked, distorted or damaged.
- Close and secure the battery access cover (under the cab).

### 12.4 - AIR-CONDITIONING (OPTION)

- Check the tension of the compressor driving belt : driving belt tension 50 kg(110,23 lb).
- Replace the internal and external air filters as necessary.



The system becomes less efficient when the circuit is being discharged. If the air conditioning unit does not work properly, have a qualified and properly equipped person examine it.



All repairs must be carried out by a qualified and authorised person.

# H - Lubrication and maintenance

## 13 - Every 500 h hours of operation

### 13.1 - LUBRICATING THE SUSPENSION AND THE DRIVER SEAT RAILS

For lubrication operations, refer to the Lubricants and equivalents table for the type of grease to be used.

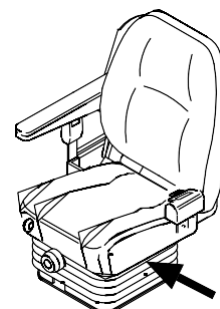

Dirt may affect correct seat operation. The seat must always be clean.

### 13.2 - AIR FILTER (SYSTEM) (FOR MACHINES FITTED WITH ENGINE PERKINS 854E-34TA OR KOHLER KDI 3404 TCR ONLY)



Perform a cleaning of the primary air cleaner elements by pressurized air or vacuum cleaning.



For all engine maintenance operations : Consult the guide provided by the engine manufacturer or HAULOTTE Services®.

*N.B.:-Operating in dirty conditions may require more frequent service of the air cleaner element.*

### 13.3 - DIESEL CIRCUIT (FOR MACHINES FITTED WITH ENGINE PERKINS 854E-34TA OR PERKINS 1104D44T ONLY)

#### 13.3.1 - Changing the diesel filter

- Open the engine canopy to access the diesel filter.
- Loosen the filter cartridge.
- Replace the used cartridge with a new one.
- Close the engine canopy again.

#### 13.3.2 - Changing the diesel pre-filter

To access the diesel pre-filter, open the engine cover.

- Loosen the transparent lower cover.
- Replace the filter.
- Carefully clean the cover.
- Retighten it manually ( 1/4 turn after contact with the seal).
- Refit the cover.

*N.B.:-Perform the first pre-filter change after the first 500 h of operation.*

# H - Lubrication and maintenance

## 13.4 - INTERNAL COMBUSTION ENGINE



For the following operations, park the machine onto a horizontal surface and turn off the engine.



Be prepared to collect the fluid with suitable containers before opening any compartment or disassembling any component containing fluids.

- Drain the motor oil :

Capacity :

Engine PERKINS 1104D44T : 8,4 l(2,2 gal US) with filters.

Engine PERKINS 854E-34TA : 9,5 l(2,5 gal US) with filters.

Engine KHOLER KDI 3404 TCR : 9,2 l(2 gal US) - Min. / 15,6 l(4 gal US) - Maximum with filters.

- Drainage is performed when hot.
- Loosen the drainage plug and let the oil flow completely (1).  
Remove the oil filling cap.

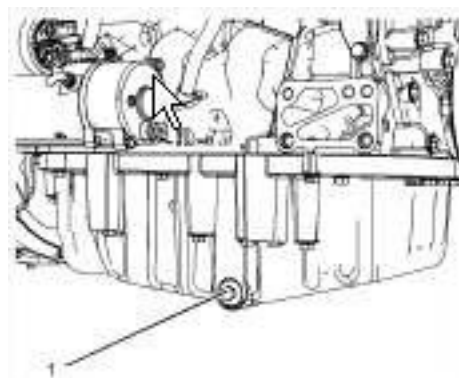

- Change the oil filter cartridge :
- Loosen and remove the filter cartridge.
- Oil the seal on the new cartridge, insert it into place on the engine carrier. Screw the cartridge manually until the seal is in place.
- Tighten the cartridge by screwing it by an additional half-turn.

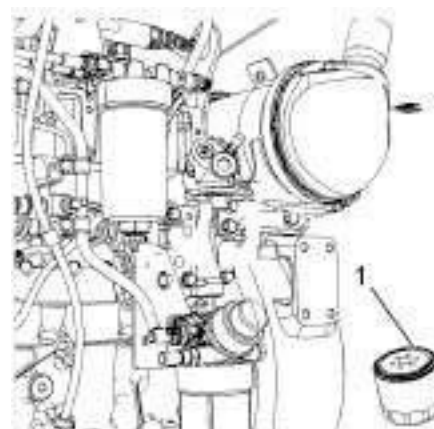

- Clean the drainage plug and replace it, taking care to change the seal.
- Fill until the oil reaches the MAXI gauge mark.
- Replace the filling cap and let the engine run at idling speed for a few minutes.
- Check the seal on the oil filter cartridge.
- Stop the engine and check the oil level. Top up the oil if necessary.

**N.B.-:** Perform the first drainage and the first oil filter cartridge change after the first 500 hours of operation.

# H - Lubrication and maintenance

## 13.5 - ENGINE OIL SERVICE RESET



After changing the engine oil and the filter, a reset must be performed to avoid engine derating.



For all engine maintenance operations : Consult the guide provided by the engine manufacturer or HAULOTTE Services®.



All repairs must be carried out by a qualified and authorised person.

## 13.6 - TRAVEL AXLES

Refer to the machine configuration to identify the logo that appears on the wheel reducer.

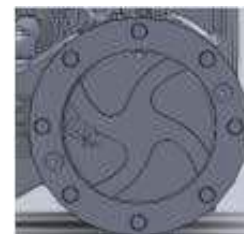
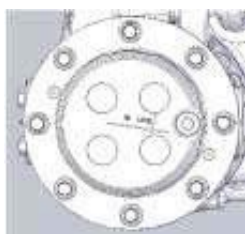

**N.B.:-**The level check operations must be performed periodically, respecting the maintenance schedule provided. It is recommended that you intervene immediately in the event of leaks or other faults may result in a drop in oil levels to avoid any possible damage to the mechanical components. Once you have removed the filling and drainage plugs, they should be refitted again and tightened using a torque value recommended by the manufacturer.

### 13.6.1 - Checking the level of the front axle

Capacity :

- Transfer case : 1,25 l(0,33 gal US).
- Front axle : 8 l(2,11 gal US).



Capacity :

- Transfer case : 0,7 l(0,18 gal US).
- Front axle : 6,5 l(1,7 gal US).



- Before performing the oil replacement operations, firstly remove the drain plugs ( 2 ) to eliminate any pressure from inside the housing.
- Loosen the control plug ( 1 ).
- The lubricant level in the axle must be at the level of the control plug ( 1 ), otherwise top up to the correct level via the same hole.
- Refit the control plugs ( 1 ) and the drain plugs ( 2 ).

# H - Lubrication and maintenance

 Section H 18.2 - Refer to the Lubricants and equivalents table for the type of oil used.

- Take advantage of this operation to clean the drain plugs ( 2 ).

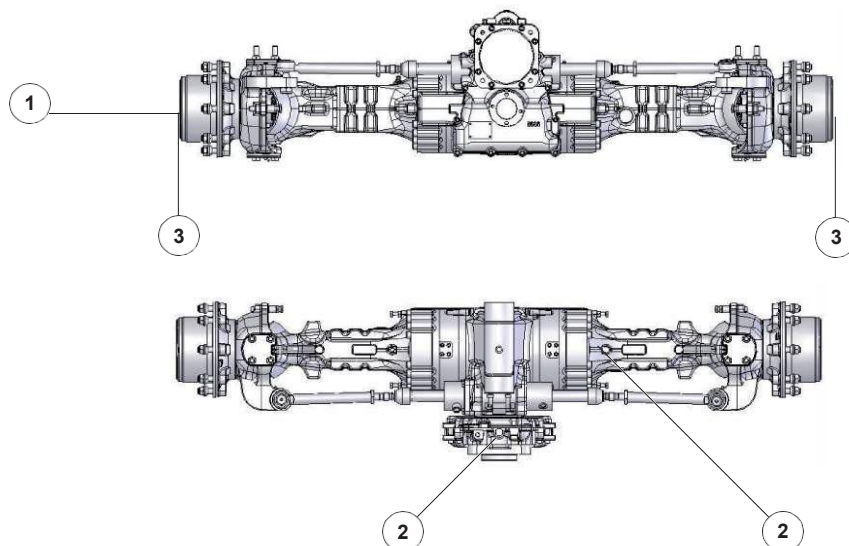

### 13.6.2 - Checking the level of the rear axle

Capacity :

- Rear axle : 8,5 l(2,24 gal US).



Capacity :

- Rear axle : 7,2 l(1,9 gal US).



- Before performing the oil replacement operations, firstly remove the drain plugs ( 2 ) to eliminate any pressure from inside the housing.
- Loosen the control plug ( 1 ).
- The lubricant level in the axle must be at the level of the control plug ( 1 ), otherwise top up to the correct level via the same hole.
- Refit the control plugs ( 1 ) and the drain plugs ( 2 ).

 Section H 18.2 - Refer to the Lubricants and equivalents table for the type of oil used.

# H - Lubrication and maintenance

- Take advantage of this operation to clean the control plugs ( 1 ) and the drain plugs ( 2 ).

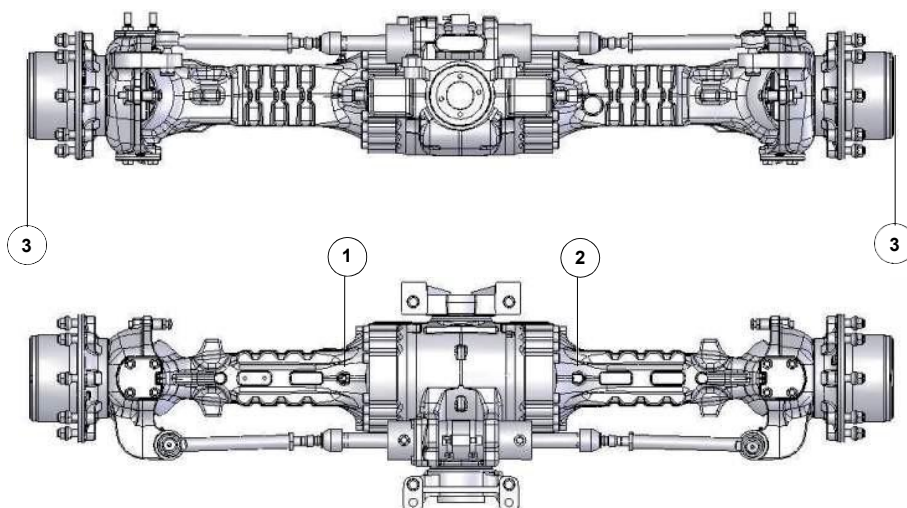

### 13.6.3 - Checking the level of the epicycloidal reducers

**N.B.:-** To check the reducer oil level, you must move the machine to position the closure plug in the required positions. Due to the presence of the differential on each of the axles, you will have to repeat this operation individually for each of the machine wheels.

Capacity : 4 x 0,8 l(4 x 0,21 gal US)



Capacity : 4 x 0,9 l(4 x 0,23 gal US)



- When it is in the high position, loosen the plug ( 3 ) by a few turns, to release any internal pressure from the housing and then close it again.
- Drive the machine slowly to bring the plug to horizontal position.
- Loosen the plug completely : the oil level must arrive at the plug, otherwise top up to the correct level via the same hole.
- Refit the plug ( 3 ).

 Section H 18.2 - Refer to the Lubricants and equivalents table for the type of oil used.

# H

 - Lubrication and maintenance

## 14 - Every 1000 h hours of operation (or once a year)

### 14.1 - CHAIN WEAR

Have the chain wear checked by a HAULOTTE Services® technician.

### 14.2 - PRIMARY AIR FILTER



Never clean the cartridge by hitting it against a hard surface or by using hot flammable liquid.

Change the filter cartridge :

- Remove the cover :
- Pull the trigger situated on the cover ( 1 ).
- Locate the angular position of the cover which should be identical upon reassembly.
- Turn the cover to the right ( 2 ).
- Pull the cover to remove it.
- Turn and pull the outer cartridge.

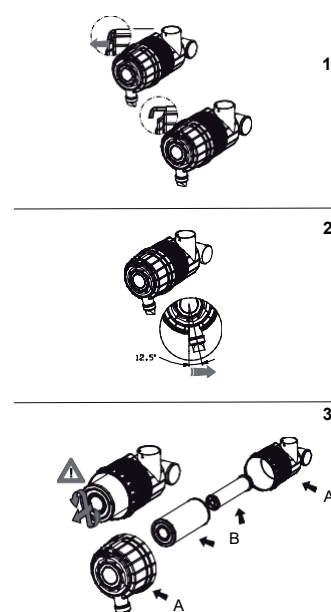

- Change the outer filter cartridge.
- Refit the cover, checking that the dust evacuation valve is directed downwards.

### 14.3 - INTERNAL COMBUSTION ENGINE



For the following operations, park the machine onto a horizontal surface and turn off the engine.

- Check that the engine supports and the vibratory mount supports are in good condition.



For all engine maintenance operations : Consult the guide provided by the engine manufacturer or HAULOTTE Services®.

# H - Lubrication and maintenance

## 14.4 - HYDRAULIC CIRCUIT

### 14.4.1 - Equipment hydraulic circuit

- Change the hydraulic filter cartridge :
- Place the machine in the working position and stop the engine.
- Open the engine compartment by removing the lower protective covers.
- Loosen the casing from the transmission hydraulic filter.
- Change the filter cartridge.
- Start the engine.
- Perform driving movements.
- Check the oil level and top up if necessary.
- Close the casing again.

**N.B.:** - Perform the first filter change after the first 500 hours of operation.

### 14.4.2 - Transmission hydraulic circuit

- Change the hydraulic filter cartridge :
- Place the machine in the working position and stop the engine.
- Open the engine compartment by removing the lower protective covers.
- Loosen the casing from the transmission hydraulic filter.
- Change the filter cartridge.
- Switch on the engine and perform travel movements.
- Check the oil level and top up if necessary.
- Close the casing again.

**N.B.:** - Perform the first filter change after the first 500 hours of operation.

## 14.5 - ACCUMULATORS

You are advised to check the pre-charge pressure regularly via the M28x1,5 orifice used for adding gas.

- Accumulator 1 l(0,26 gal US) : Pre-charge pressure : 13 bar(188 psi) (Parking brake circuit).
- Accumulator 0,75 l(0,20 gal US) : Pre-charge pressure : 30 bar(435 psi) (Service brake circuit).



This operation requires specific tools (Consult HAULOTTE Services®) and a bottle of nitrogen to recharge the accumulator (if the pre-charge pressure drops).



The accumulators must be emptied before any maintenance operation :  Section H 18.1 - Replacement of the brake circuit accumulators.

# H - Lubrication and maintenance

## 14.6 - TRAVEL AXLES

Refer to the machine configuration to identify the logo that appears on the wheel reducer.

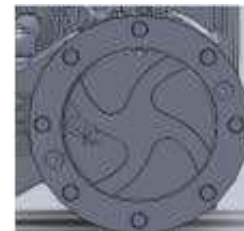
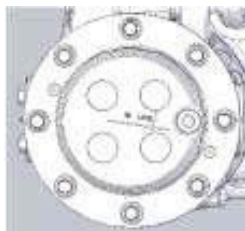

The oil replacement operations must be performed periodically, respecting the maintenance schedule provided.

It is recommended that you intervene immediately in the event of leaks or other faults may result in a drop in oil levels to avoid any possible damage to the mechanical components.

Once you have removed the filling and drainage plugs, they should be refitted again and tightened using a torque value recommended by the manufacturer.

Perform the first drainage after the first 250 hours of operation.

### 14.6.1 - Draining the front axle

Capacity :

- Transfer case : 1,25 l(0,33 gal US).
- Front axle : 8 l(2,11 gal US).



Capacity :

- Transfer case : 0,7 l(0,18 gal US).
- Front axle : 6,5 l(1,7 gal US).



- Before performing the oil replacement operations, firstly remove the drain plugs ( 2 ) to eliminate any pressure from inside the housing.
- Loosen the drainage plug ( 4 ) and let the oil drain out.
- Refit and tighten the drain out ( 4 ).
- Loosen the control plug ( 1 ).
- Fill the axle, the lubricant level in the axle must be level with the control plug ( 1 ).
- Refit the control plugs ( 1 ) and the drain plugs ( 2 ).

 Section H 18.2 - Refer to the Lubricants and equivalents table for the type of oil used.

# H - Lubrication and maintenance

- Take advantage of this operation to clean the drain plugs ( 2 ).

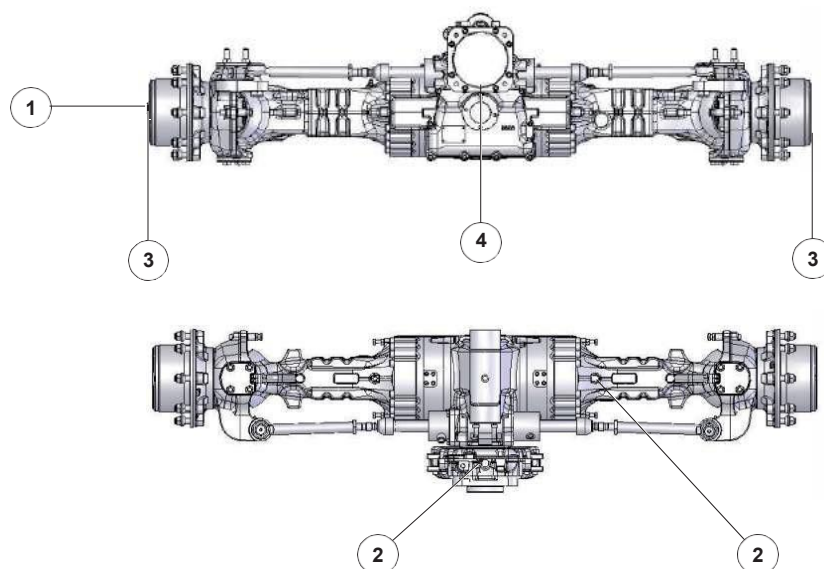

## 14.6.2 - Draining the rear axle

Capacity :

- Rear axle : 8,5 l (2,24 gal US).



Capacity :

- Rear axle : 7,2 l (1,9 gal US).



- Before performing the oil replacement operations, firstly remove the drain plugs ( 2 ) to eliminate any pressure from inside the housing.
- Loosen the drainage plug ( 4 ) and let the oil drain out.
- Refit and tighten the drain out ( 4 ).
- Loosen the control plug ( 1 ).
- Fill the axle, the lubricant level in the axle must be level with the control plug ( 1 ).
- Refit the control plugs ( 1 ) and the drain plugs ( 2 ).

# H - Lubrication and maintenance

 Section H 18.2 - Refer to the Lubricants and equivalents table for the type of oil used.

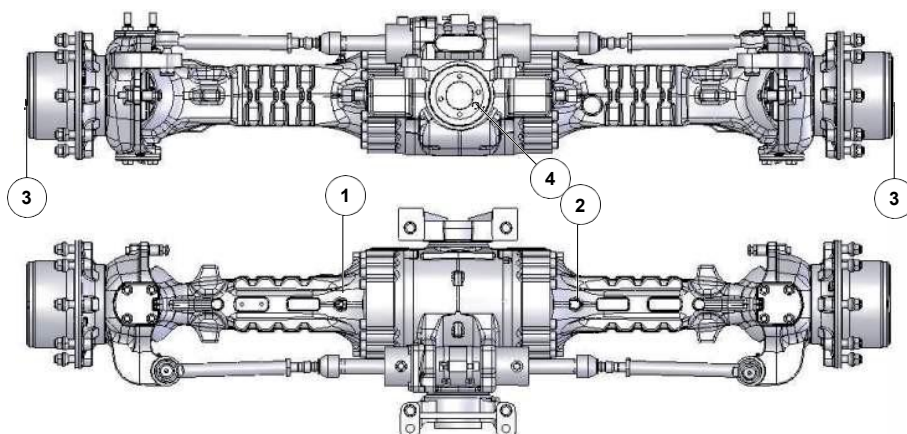

### 14.6.3 - Draining the epicycloidal reducers

**N.B.:-** To replace the reducer oil, you must move the machine to position the closure plug in the required positions. Due to the presence of the differential on each of the axles, you will have to repeat this operation individually for each of the machine wheels.

Capacity : 4 x 0,8 l (4 x 0,21 gal US)

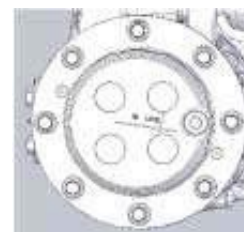

Capacity : 4 x 0,9 l (4 x 0,23 gal US)



- When it is in the high position, loosen the plug ( 3 ) by a few turns, to release any internal pressure from the housing and then close it again.
- Drive the machine slowly to bring the plug to its low position.
- Loosen the plug completely and let the oil drain out.
- Drive the machine slowly to bring the plug to horizontal position.
- Fill the reducer; the oil level must be level with the plug.
- Refit the plug ( 3 ).

 Section H 18.2 - Refer to the Lubricants and equivalents table for the type of oil used.

# H - Lubrication and maintenance

## 15 - Every 1500 h hours of operation

### 15.1 - ENGINE CRANKCASE BREATHER (ENGINE PERKINS 854E-34TA)



Before performing any interventions, let the engine cool down.



**DANGER OF BURNS!** Hot oil and hot components can cause personal injury. Avoid any contact with the skin.

The crankcase breather is a very important component in order to keep your engine emissions compliant.

- The filter element of the housing breather must be serviced according to the stated frequencies(  Section H 6 -Detailed program).
- The correct filter element must be installed before the engine is operated.
- The installation of the filter element is very important.
- The quality of the filter element that is installed is very important.
- The filter element protects the engine from excessive quantities of oil from entering the induction system. The filter element also protects the engine aftertreatment system.

**N.B.:-**Excessive quantities of oil that enter the induction system of the engine can rapidly increase the engine speed without control.

#### 15.1.1 - Remove the breather element

- Remove the guard that covers the engine breather.
- If necessary, remove breather pipes on cover ( 6 ).
- Remove circlip ( 4 ) and remove the breather element ( 3 ) and discard.
- Remove the O ring seal ( 5 ) from the cover.

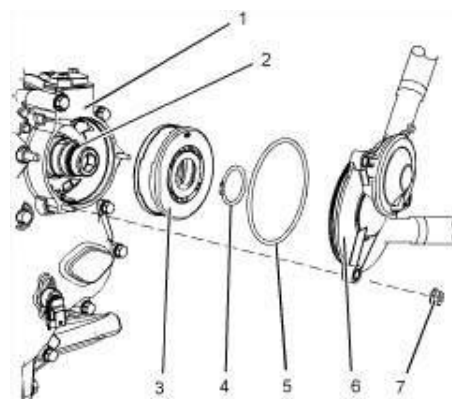

# H - Lubrication and maintenance

## 15.1.2 - Install the breather element



Ensure that all the components are clean and free from damage.

- Install a new O ring seal ( 5 ) onto the cover ( 6 ).

**N.B.-***The breather element must have the correct orientation before installation. Diameter ( A ) is visibly larger than diameter ( B ).*

- Install diameter ( A ) of the breather element ( 3 ) onto the shaft ( 2 ). When correctly installed the part number of the breather element will be visible.
- Install circlip ( 4 ) and cover ( 6 ). Install nuts ( 7 ) and tighten to 25 Nm (18 lb ft). If necessary, install breather pipes to cover.
- Install the guard that covers the engine breather.

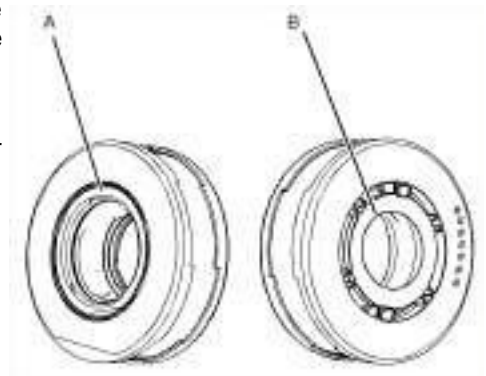

# H - Lubrication and maintenance

## 16 - Every 2000 h hours of operation (or every 2 years)

### 16.1 - COOLING SYSTEM (ENGINE PERKINS 1104D44T)



Before performing any interventions, let the engine cool down.

- Change the coolant :

Capacity : approx. 18 l(4,75 gal US).

**N.B.-:** -Open the heating valve situated in the cab when draining the cooling system.

- Remove the filter cap from the expansion bottle filter cap.
- Loosen the drainage plug and let the coolant drain out.
- Empty the expansion bottle.
- Clean the system thoroughly with water (or, if necessary, with a cleaning product). In this case, retighten the plug and let the engine run at mid throttle for 10 mn, stop the engine and drain the system again.
- Refit the drainage plug.
- Filling the cooling system :
  - Remove the filter cap from the expansion bottle filter cap.
  - Fill the radiator GRADUALLY until the coolant has reached the correct level.
  - Close the expansion bottle cap again.
- Switch the acceleration control lever to IDLING.
- Start the engine.
- Let the engine run AT IDLING SPEED for approx. 2 mn.
- Stop the engine.
- Open the expansion bottle and top up if necessary.

A

B

C

D

E

F

G

H

I



# H - Lubrication and maintenance

## 16.2 - AIR FILTER (SYSTEM)



**Never clean the cartridge by hitting it against a hard surface or by using hot flammable liquid.**

Change the filter cartridge :

- Remove the cover :
- Pull the trigger situated on the cover (  Section H 8.5 Marking1).
- Locate the angular position of the cover which should be identical upon reassembly.
- Turn the cover to the right (  Section H 8.5 Marking2).
- Pull the cover to remove it.
- Turn and pull the (primary) outer cartridge. Then pull the (secondary) inner cartridge (  Section H 8.5 Marking3).
- Insert a new secondary cartridge, by pushing it to the bottom of the socket provided in the case.
- Place the new primary cartridge above the secondary cartridge, insert it in place with a rotation movement near the stop.
- Refit the cover, checking that the dust evacuation valve is directed downwards.



**Never clean the secondary filter.**



**Check the state of the sealing ring before reassembling the cartridges.**

***N.B.**:-Perform the secondary cartridge change every 2 years or after every 5 maintenance operations.*

## 16.3 - INTERNAL COMBUSTION ENGINE (ENGINE PERKINS 1104D44T)

- Change the engine belts.



**For all engine maintenance operations : Consult the guide provided by the engine manufacturer or HAULOTTE Services®.**

# H - Lubrication and maintenance

## 16.4 - HYDRAULIC CIRCUIT

- Checking the hydraulic pressures.

This operation must be performed by a HAULOTTE Services® technician.

- Change the oil :

Tank capacity : 103 l(27 gal US)

Replace oil after each major intervention, and each time an anomaly has been detected.

- Only use oils that match the technical characteristics that correspond to HAULOTTE® recommendations.



**Do not mix two oils with different characteristics : If necessary, drain and clean the whole system.**

- Check the cleanliness of the oil filter cartridge (no metal shavings, rubber, plastic, ...) : If necessary, drain and clean the whole system.

When the tank is empty :



**Drainage must be performed when the oil is hot.**

- Place the machine in its folded position.
- Stop the engine.
- Go underneath the machine.
- Remove the filling cap ( 2 ).
- Loosen the drainage plug ( 1 ) and let the oil drain out.

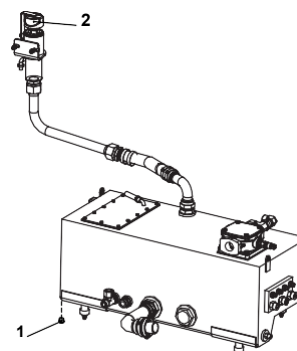

- Fill the tank with the recommended oil until the gauge indicates the max. level.



- Refit the filling cap ( 2 ).
- Start the engine.
- Actuate the equipment controls in both directions for approx. five minutes (without placing the cylinders at the stops 2).
- Place the machine in road position.
- Check the oil level in the hydraulic oil tank : Hydraulic oil level must be between the min. and max. marks recommended. Top up the oil if necessary.

Refer to the Lubricants and equivalents table for the type of oil used.

# H - Lubrication and maintenance

## 16.5 - AIR-CONDITIONING (OPTION)



**Maintenance and repair work on the air conditioning must be carried out by a qualified and authorised person.**

- Cleaning of condenser and evaporator coils.
- Cleaning of condenser water outlets.
- Recovery of coolant in order to replace the filter-drier.
- Top up with coolant and check of thermostatic regulation and pressure switches.



**Any top up on the circuit must be carried out by a qualified and authorised person.**



**Never open the circuit as this would cause a loss of coolant. The cooling circuit contains a gas which, under given circumstances, may present some risks. This gas, i.e. the R-134a coolant, is colourless and odourless and heavier than air. It is a stable product at normal temperature.. The compressor is fitted with a gauge to check the oil level : Never unscrew this lid, as this would discharge the system. The oil level is only checked when the oil is changed.**

# H - Lubrication and maintenance

## 17 - Every 3000 h hours of operation (or every 3 years)

### 17.1 - INTERNAL COMBUSTION ENGINE (ENGINE PERKINS 854E-34TA)

- Change the engine belts.



For all engine maintenance operations : Consult the guide provided by the engine manufacturer or HAULOTTE Services®.



All repairs must be carried out by a qualified and authorised person.

### 17.2 - DIESEL PARTICULATE FILTER (ENGINE PERKINS 854E-34TA)

- Have the particulate filter cleaned.



For all engine maintenance operations : Consult the guide provided by the engine manufacturer or HAULOTTE Services®.



All repairs must be carried out by a qualified and authorised person.

A

B

C

D

E

F

G

H

I

# H - Lubrication and maintenance

## 17.3 - COOLING SYSTEM (FOR MACHINES FITTED WITH ENGINE PERKINS 854E-34TA OR KOHLER KDI 3404 TCR ONLY)



Before performing any interventions, let the engine cool down.

- Change the coolant :

Capacity : approx. 18 l(4,75 gal US).

**N.B.-:** Open the heating valve situated in the cab when draining the cooling system.

- Remove the filter cap from the expansion bottle filter cap.
- Loosen the drainage plug and let the coolant drain out (1).
- Empty the expansion bottle.
- Clean the system thoroughly with water (or, if necessary, with a cleaning product). In this case, retighten the plug and let the engine run at mid throttle for 10 mn, stop the engine and drain the system again.
- Refit the drainage plug.

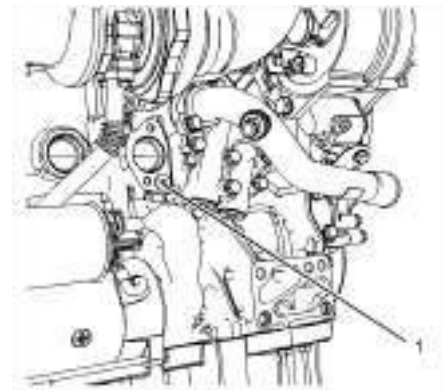

- Filling the cooling system :
- Remove the filter cap from the expansion bottle filter cap.
- Fill the radiator GRADUALLY until the coolant has reached the correct level.
- Close the expansion bottle cap again.
- Switch the acceleration control lever to IDLING.
- Start the engine.
- Let the engine run AT IDLING SPEED for approx. 2 mn.
- Stop the engine.
- Open the expansion bottle and top up if necessary.

# H - Lubrication and maintenance

## 18 - Every 5000 h hours of operation (or every 5 years)

### 18.1 - INTERNAL COMBUSTION ENGINE (ENGINE KOHLER KDI 3404 TCR)

- Change the engine belts.



For all engine maintenance operations : Consult the guide provided by the engine manufacturer or HAULOTTE Services®.



All repairs must be carried out by a qualified and authorised person.

## 19 - Every 10 years

### 19.1 - REPLACEMENT OF THE BRAKE CIRCUIT ACCUMULATORS

Replacement involves :

- Accumulator 1 l(0,26 gal US) : Parking brake circuit.
- Accumulator 0,75 l(0,20 gal US) : Service brake circuit.



For the following operations, park the machine onto a horizontal surface and turn off the engine.



Never undertake maintenance on the accumulators with the engine running.

#### 19.1.1 - Parking brake



Only begin working on the accumulator 24 h minimum after the previous time the engine was started. This is the time necessary for the accumulator to fully discharge to allow it to be removed and replaced safely.



Maintenance operations on accumulators are dangerous (pressurised oil) ; the procedure must be strictly adhered to and extreme caution must be exercised when removing this part.

#### 19.1.2 - Service brake

Press the brake pedal 40 times in a row with the engine switched off in order to empty the accumulator to allow the accumulator to be changed over without danger.







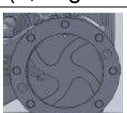

Maintenance operations on accumulators are dangerous (pressurised oil) ; the procedure must be strictly adhered to and extreme caution must be exercised when removing this part.

**N.B.**:-: Accumulator inflation pressure must be checked regularly once a year (  Section H 14.5 - Accumulator).

# H - Lubrication and maintenance

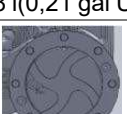
## 19.2 - LUBRICANTS AND EQUIVALENTS

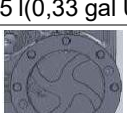
Uses	Capacities	ISO	MIL API	Manufacturer references					
				BP	ELF	ESSO	MOBIL	AGIP	SHELL
Pins and hinges		6743/0 catégorie X			EPEXELF 2				
Upper boom		Grade 2 ou 3			Multimove 2				
Driver seat rails						Multi-Purpose Grease (Moly)			
<b>Oils</b>									
Front axle and differential**	 8 l(2,11 gal US)	SAE 80W90*						ROTRA MULTI THC/C 80W90	SPIRAX LS 80W90
	 6,5 l(1,7 gal US)								
Rear axle and differential**	 8,5 l(2,24 gal US)	SAE 80W90*						ROTRA MULTI THC/C 80W90	SPIRAX LS 80W90
	 7,2 l(1,9 gal US)								
Wheel reducer**	 0,8 l(0,21 gal US)	SAE 80W90*	MIL-L2105 API GL5	ENERGEA R 90 80W90	TRANSELF TYPE 80W90	ESSO GEAR GX SAE 80W90		ROTRA MULTI THC/C 80W90	SPIRAX LS 80W90
	 0,9 l(0,23 gal US)								
Transfer case**	 1,25 l(0,33 gal US)	SAE 80W90*	MIL-L2105 API GL5	ENERGEA R 90 80W90	TRANSELF TYPE 80W90	ESSO GEAR GX SAE 80W90		ROTRA MULTI THC/C 80W90	SPIRAX LS 80W90
	 0,7 l(0,18 gal US)								
Hydraulic circuit***	175 l(46,2 gal US)	HV 46		ENERGOL SHF-HV 46	HYDRELF DS46	INVAROL EP46	DTE 15M SERIE		HYDRAULI C PW 46

# H - Lubrication and maintenance

Internal combustion engine (PERKINS 1104D44T)	8,4 l(2,2 gal US)	SAE 15W40	MIL-2140E	VANELLUS C5 DIESEL53 15W40	ELF PERFORMANCE SUPER D 15W40	ESSO TUBE XT301 SAE 15W40	DELVAC M 15W40		RIMULAX 15W40
Internal combustion engine (PERKINS 854E-34TA)	9,5 l(2,5 gal US)	SAE 15W40	MIL-2140E						RIMULA R5 LE 10W-40
Internal combustion engine (KOHLER KDI 3404 TCR)	9,2 l(2 gal US) - Min. 15,6 l(4 gal US) - Maximum	SAE 15W40							RIMULA R5 LE 10W-40

\* : Uses an additive for axles fitted with a limited slip differential.

\*\* : The axle manufacturer recommends using SHELL or AGIP products.

**N.B.-** The oils indicated above are valid for use at ambient temperatures of between  $-15\text{ }^{\circ}\text{C}(5\text{ }^{\circ}\text{F})$  and  $40\text{ }^{\circ}\text{C}(104\text{ }^{\circ}\text{F})$ . If the equipment operates outside this temperature range, refer to the oil viscosity tables below.

\*\*\* : Below an ambient temperature of  $-15\text{ }^{\circ}\text{C}(5\text{ }^{\circ}\text{F})$ , use TELLUS ARTIC OIL 32 (SHELL). Above an ambient temperature of  $45\text{ }^{\circ}\text{C}(113\text{ }^{\circ}\text{F})$ , use TELLUS OIL T68 (SHELL). If a biodegradable oil is required, use TELLUS naturel HSE 46 (SHELL), at interval of oil change every 1000 h.

# H - Lubrication and maintenance

## Axle oil viscosity according to the ambient temperature

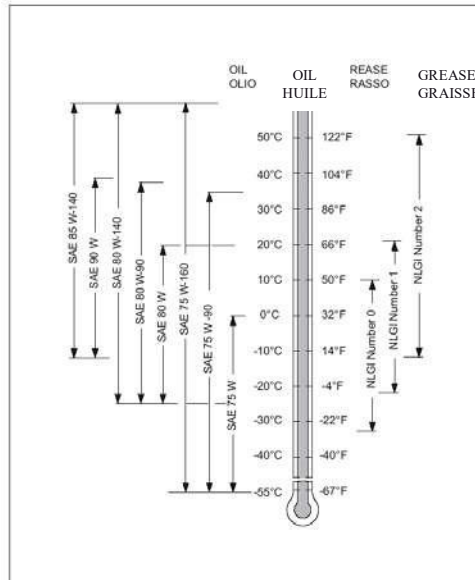

## Engine oil viscosity according to the ambient temperature

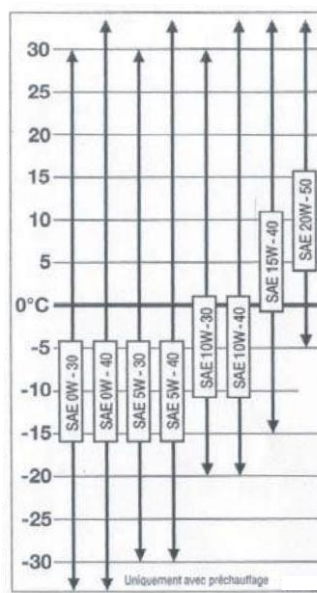

# H - Lubrication and maintenance

## 20 - Electric circuit

### 20.1 - WIRING DIAGRAM-MAIN COMPONENTS

**N.B.:-**  See end of manual.

#### Nomenclature

Marking	Description
FU100	General electrical equipment fuse
FU101	Fuse for warning lights
FU102	Fuse for calculator power supply
FU103	Fuse for flashing beacon-Horn
FU106	Fuse for indicator lights
FU107	Fuse for high beam headlights
FU108	Fuse for low beam headlights
FU109	Fuse for stop light
FU110	Fuse for front left hand sidelight
FU111	Fuse for front right hand sidelight
FU112	Fuse for rear side lights-Registration plate
FU113	Fuse for sensor power supply-Controls
FU114	Fuse for power supply to solenoid valves
FU115	Permanent power supply circuit fuse
FU117	Fuse for rear foglights
FU140	LMI power supply circuit fuse
FU161	Fuse for the engine preheat management system
FU180	Fuse for the cab heating
FU181	Air-conditioning fuse
FU182	Fuse for accessory power in the cab
FU183	Fuse for windscreen wiper-Fuse for front windscreen washer
FU184	Fuse for rear windscreen wiper
FU187A	Fuse for radio control
FU187B	Weighing fuse (Option)
FU189	Fuse for air conditioning fan-Fuse for front windscreen washer
FU191	Fuse for work light
FU195	Fuse for 12 V socket
FU620	Fuse for reversing alarm
KA104	Relay for flasher indicator
KA107	Relay for high beam headlights
KA108	Relay for headlights
KA110	Relay for sidelight validation
KA160	Relay for auxiliary starter control
KA181	Relay for air conditioning
KA187	Radio-control relay
KA189	Relay for air conditioning heat sink ventilation
KA122	Solenoid valve control relay
KA161	Motor stop relay
KA620	Relay for reversing alert
KM100	Main contactor/battery isolation switch
KM160	Pre-heating relay (Engine PERKINS 1104D44T)

# H - Lubrication and maintenance

## 21 - Hydraulic circuit

### 21.1 - HYDRAULIC DIAGRAM-MAIN COMPONENTS

**N.B.:-**  See end of manual.

#### Nomenclature

Marking	Description
1	Return line hydraulic filter
2	Drive hydraulic pump
3	Drive hydraulic pump
4	Hydraulic pressure filter
5	Steering unit
6	Hydraulic pump PTO
7	Main proportional directional valve
8	Valve ON/OFF
9	Parking brake unit
10	Check valve
11	Check valve
12	Conjunction-Disjunction unit
13	Accumulator
14	Accumulator
15	Steering selector valve
16	Oscillating axle locking valve
17	Service brake valve
18	Control valve Float (Option)
19	Hydraulic drive engine
20	Hydraulic oil cooler fan motor - Hydraulic motor
21	Boom lift cylinder
22	Boom telescopic cylinder
23	Level compensation cylinder
24	Level compensation cylinder
25	Stabiliser cylinder
26	Load levelling cylinder
27	Oscillating axle locking cylinder
28	18 b pressure switch
29	90 b pressure switch
30	5 b pressure switch
31	150 b pressure switch
32	Recharge valve

# H - Lubrication and maintenance

## 22 - Troubleshooting

Stop the machine and contact HAULOTTE Services® if the following LEDs flash or remain lit :

- Parking brake defect LED P182 : Not enough pressure.
- Engine oil pressure fault LED P181 : Not enough pressure.
- Service brake fault LED P190 : Not enough pressure.
- Battery LED P180 : Wiring problem.
- LED P191.

The machine is equipped with an on-board defect detection system.

Default code, reported at the display tells to the user the nature of the faulty.

The machine switches to downgraded mode, depending on the type of fault : Certain movements can be limited or forbidden to preserve the operator's safety.

(A) : The fault is only indicated on the display if it is active.

(D) : The fault is indicated on the display when it is detected after starting up the machine, whether it is still active or not.

### Diagnosis

Faults	Description	Solution
F02 : Contactor		
F02.03(D)	Main contactor fault	Check KMG
F02.05(D)	Pre/post heating relay fault	Check KM160
F03 : Relay		
F03.08 (D)	Start-up relay fault	Check KA160
F03.09 (D)	Engine power supply relay fault / Ignition key	Check KA161
F03.12 (D)	PWM supply relay fault	Check KA122
F04 : Solenoid valves		
F04.02 (D)	Fork carriage compensation PWM solenoid valve fault	Check YV400 or YV420
F04.05 (D)	Boom lifting PWM solenoid valve fault	Check YV300 or YV320
F04.06 (D)	Boom telescoping PWM solenoid valve fault	Check YV340 or YV360
F04.23 (D)	Accessory control solenoid valve fault	Check YV121, YV123 and YV124
F04.24 (D)	Left-hand stabiliser solenoid valve fault	Check YV122, YV700 and YV720
F04.25 (D)	Right-hand stabiliser solenoid valve fault	Check YV122, YV701 and YV721
F04.28 (D)	Tilt correction solenoid valve fault	Check YV122, YV740 and YV760
F04.29 (D)	Rear-axle unlocking solenoid valve fault	Check YV780, YV781 and YV783
F04.30 (D)	Floating lift TOR solenoid valve	Check YV380
F04.32 (D)	Hydraulic unlocking TOR solenoid valve fault	Check YV380
F04.33 (D)	Steering mode TOR solenoid valve fault	Check YV680 or YV681
F05 : Joystick		
F05.03 (D)	Joystick operation defect (Boom telescoping)	Check SJ120
F05.04 (D)	Joystick operation defect (Lifting)	Check SJ120
F05.07 (D)	Joystick operation defect (Equipment carriage compensation)	Check SJ120
F05.08 (D)	Joystick operation defect (Attachments)	Check SJ120
F05.09 (D)	Operating fault on the remote control joystick (Boom telescoping)	Check B402 (Radio-control)
F05.10 (D)	Operating fault on the remote control joystick (Lifting)	Check B401 (Radio-control)
F05.11 (A)	Neutral position of the cab joystick not detected since start-up	Check SJ120

# H - Lubrication and maintenance

Faults	Description	Solution
F05.12 (A)	Neutral position of one of the joysticks on the remote control not detected since start-up	Check B401 or B402 (Radio-control)
F05.13 (A)	Neutral position of one of the rollers on the cab joystick not detected since start-up	Check B302 or B303
F07 : Sensors		
F07.03 (D)	Boom angle sensor incoherence	Check B403 or B404
F07.11 (D)	Telescope length incoherence	Check SQ360 or SQ340
F07.25 (D)	Inconsistency between pre-alarm and alarm LMI	Check B130 or B142
F07.26 (D) <sup>1</sup>	Accelerator pedal position fault	Check RP160
F07.28 (D)	Left outrigger sensor incoherence	Check SQ700 or SQ720
F07.29 (D)	Right outrigger sensor incoherence	Check SQ701 or SQ721
F07.30 (D)	Engine oil pressure sensor inconsistency	Check SP162
F07.31 (D)	Alternator D+ signal inconsistency	Check D+
F08 : Electric circuit		
F08.04 (D)	ECU power supply fault	Check the power supply
F08.05 (D)	Voltage 5 V	Check the 5 V power supply
F09 : Engine		
F09.01 (D)	Engine overheating	
F09.02 (D)	Low engine oil pressure	
F09.03 (D)	Presence of water in diesel fuel	
F09.04 (D) <sup>1</sup>	Clogged air filter	
F09.07 (D) <sup>1</sup>	Drive motor faulty	Check Engine
F09.08 (D) <sup>1</sup>	Engine shutdown	Engine shutdown
F09.10 (D)	Alternator fault	Check D+
F10 : Functions		
F10.05 (A)	Angle sensor not calibrated or calibration not valid	Calibrate B403 and B404
F11 : Security devices		
F11.05 (A)	LMI alarm shunted with the key	Caution
F12 : Internal faults		
F12.01 (D)	ECU fault / CAN link	Check the connections
F12.02 (D)	ECU EEPROM fault	Change the calculator
F12.04 (D)	Machine parameter reset	Check the parameters
F13 : Switches		
F13.03 (D)	Inconsistency in the position of the compensation selector (Radio-control emitter)	Check B104 or B105
F13.04 (D)	Inconsistency in the position of the accessory control selector (Radio-control emitter)	Check B102 or B103
F13.05 (D)	Inconsistency in the position of the Platform/Fork/Winch selector (Cab)	Check SA187
F13.06 (D)	Inconsistency in the position of the Steering mode selector (Cab)	Check SA681
F13.07 (D)	Inconsistency in the position of the drive selector (Cab)	Check SA600 or SA620
F13.08 (D)	Inconsistency in the position of the Left/Right stabiliser selector (Cab)	Check SA780 or SA781
F13.09 (D)	Inconsistency in the position of the tilt correction selector (Cab)	Check SA782
F13.10 (A)	Neutral position of one of the cab selectors not detected since start-up	Check the switches in the cab
F13.11 (A)	Neutral position of one of the remote control selectors not detected since start-up	Check the remote control switches
F14 : Driving pump		
F14.01 (D)	H1 pump fault	Check the drive pump
F14.02 (D)	Fault on the H1 pump inputs	Check the drive pump
F14.03 (D)	Fault on the H1 pump outputs	Check the drive pump
F14.04 (D)	H1 pump in safety mode	Check the drive pump

# H - Lubrication and maintenance

Faults	Description	Solution
F14.05 (A)	Inching pedal not calibrated or faulty	Check the inching pedal
F14.06 (D)	Engine rotation speed sensor fault	Check sensor
F15 : Protocol		
F15.06 (A)	CAN J1939 message not received	Check CAN 2

<sup>1</sup> : For machines fitted with engine PERKINS 854E-34TA only.

## 22.1 - PROCEDURE

- Note the fault codes
- Note any other LED's that may be lit and the situation of the machine when the defect appears.
- Stow the Telehandler.
- Stop the Telehandler.



**Do not use the machine until the fault has been repaired.**

- Service the machine as set out in this manual.

# H - Lubrication and maintenance



## Notes

# I - Intervention register

## 1 - Intervention register

The intervention register keeps a record of maintenance and repair work carried out inside or outside the maintenance programme.

**N.B.:**-In the case of a HAULOTTE Services® intervention, the qualified technician must indicate the HAULOTTE Services® intervention number.

Date	Type of intervention	Number of hours	Intervenor	HAULOTTE Services® intervention number

# I - Intervention register

Date	Type of intervention	Number of hours	Intervenor	HAULOTTE Services® intervention number

# I - Intervention register

Date	Type of intervention	Number of hours	Intervenor	HAULOTTE Services® intervention number

- A
- B
- C
- D
- E
- F
- G
- H
- I

# I - Intervention register

Date	Type of intervention	Number of hours	Intervenor	HAULOTTE Services® intervention number

# I - Intervention register

Date	Type of intervention	Number of hours	Intervenor	HAULOTTE Services® intervention number

- A
- B
- C
- D
- E
- F
- G
- H

# I - Intervention register

Date	Type of intervention	Number of hours	Intervenor	HAULOTTE Services® intervention number

# 1 - HTL 3614 - HTL 8045 - HTL 3617 - HTL 8055 - HTL 4014 - HTL 9045 - HTL 4017 - HTL 9055

1.1 - FOLIO 1/16

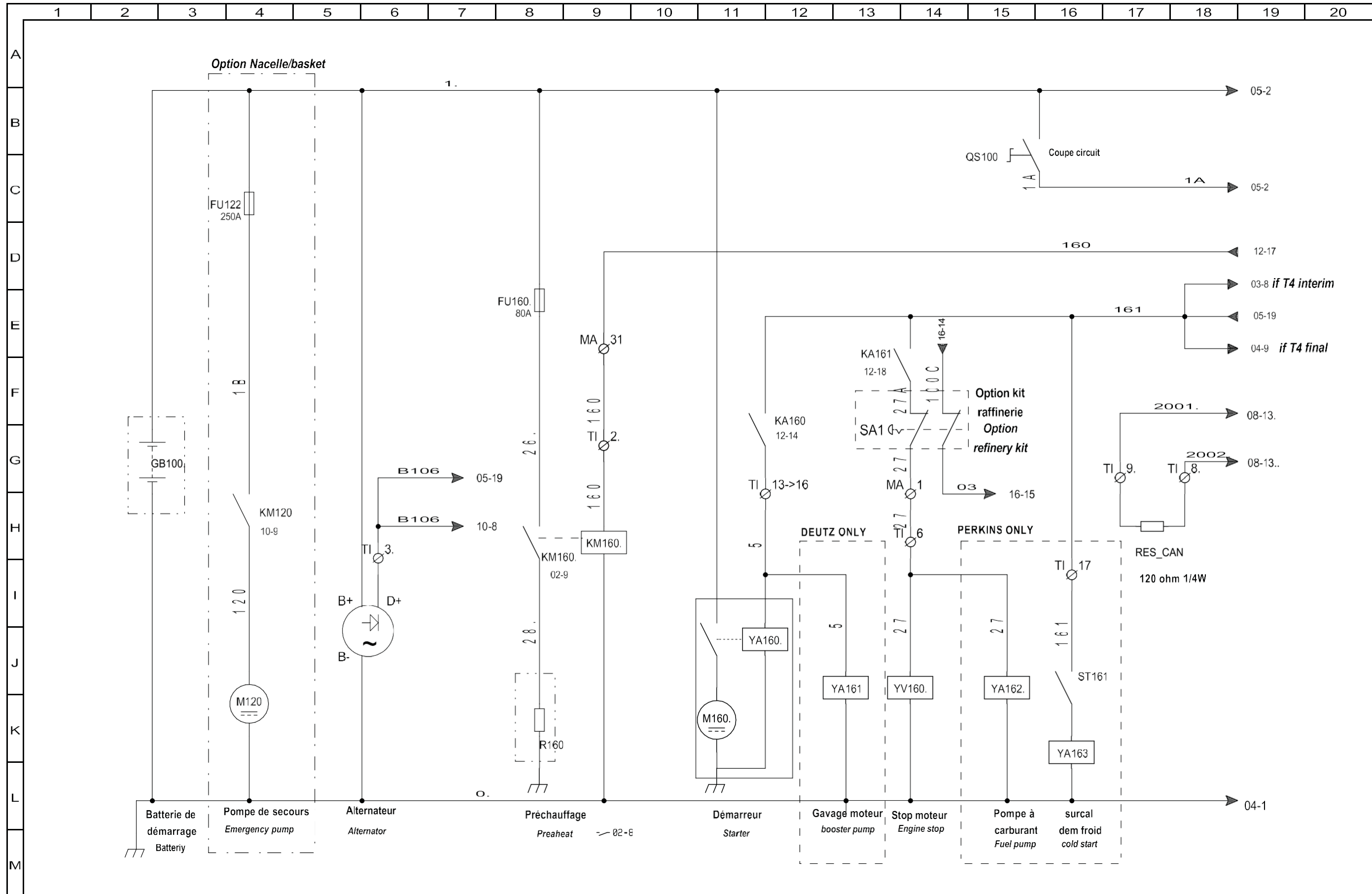



### 1.3 - FOLIO 3/16

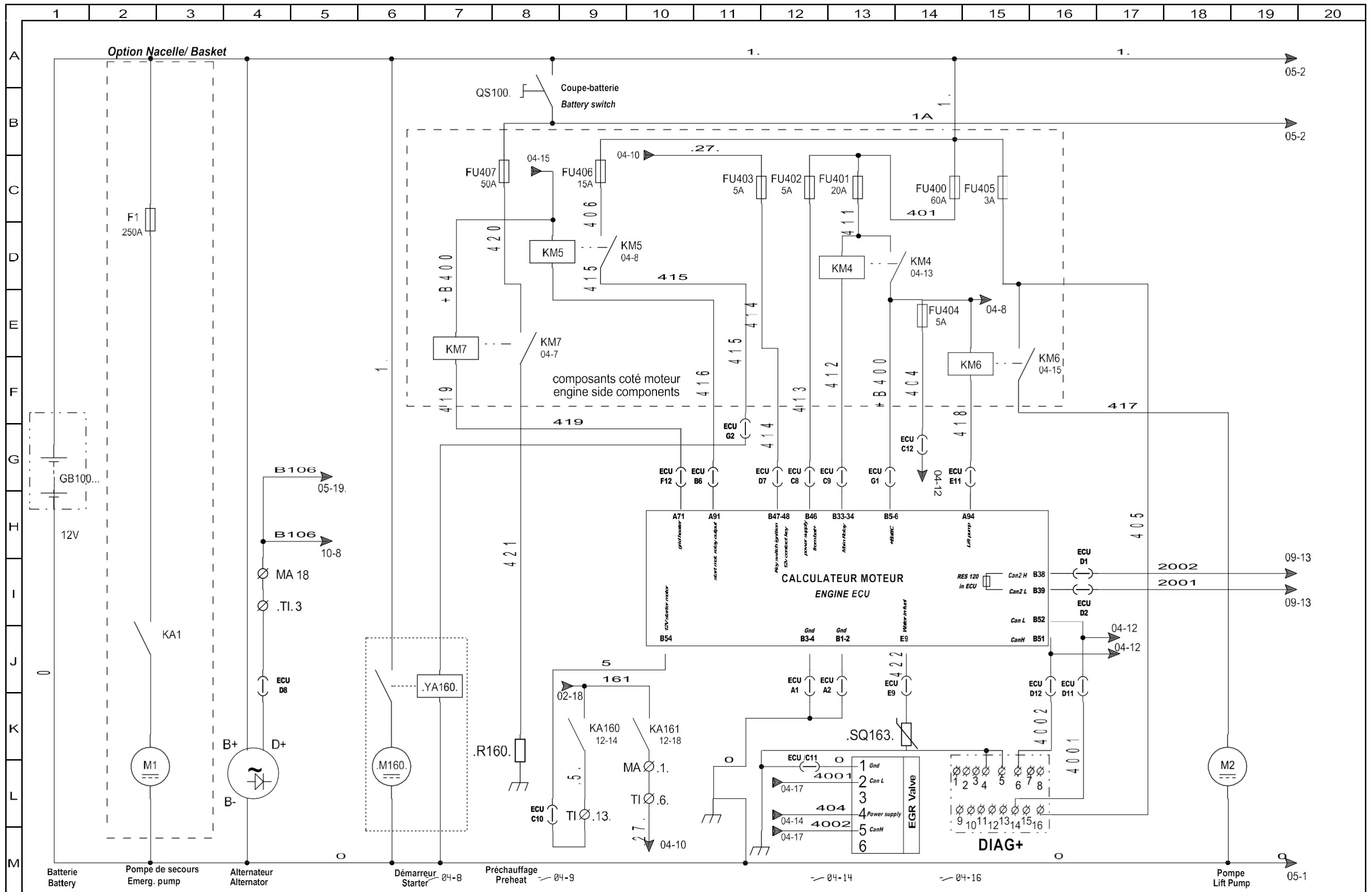

### 1.4 - FOLIO 4/16

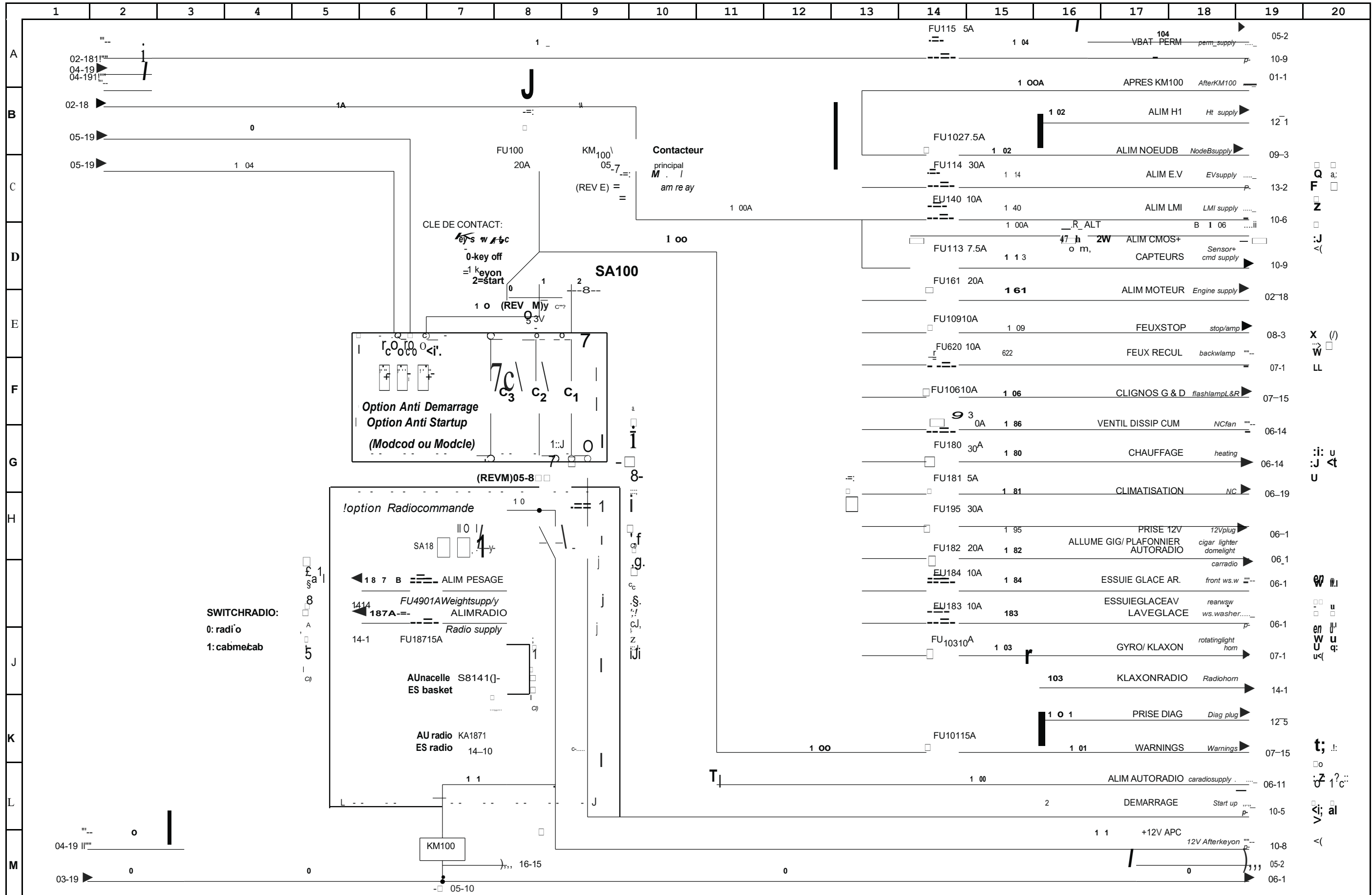



### 1.6 - FOLIO 6/16

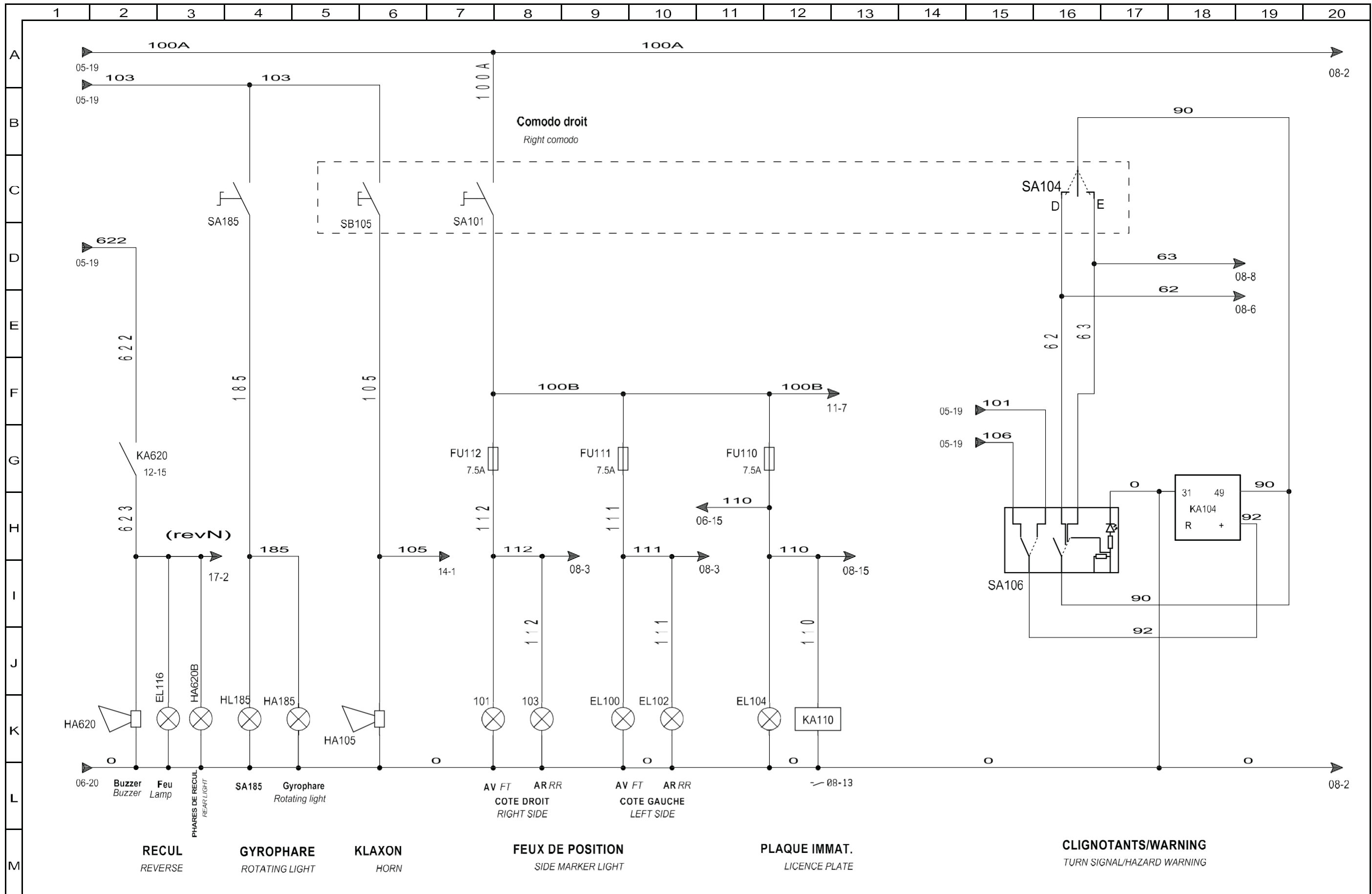

### 1.7 - FOLIO 7/16

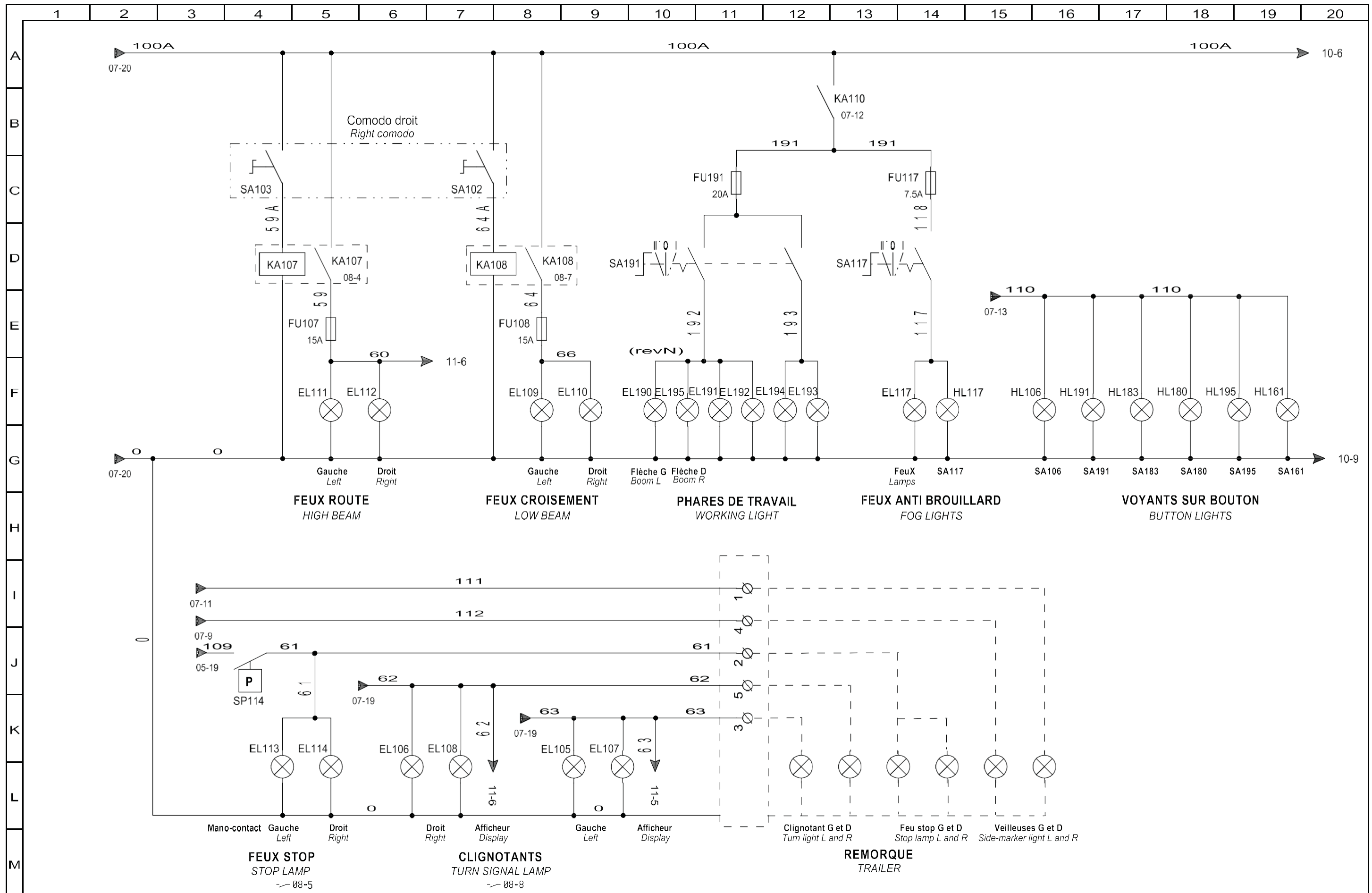

1.8 - FOLIO 8/16

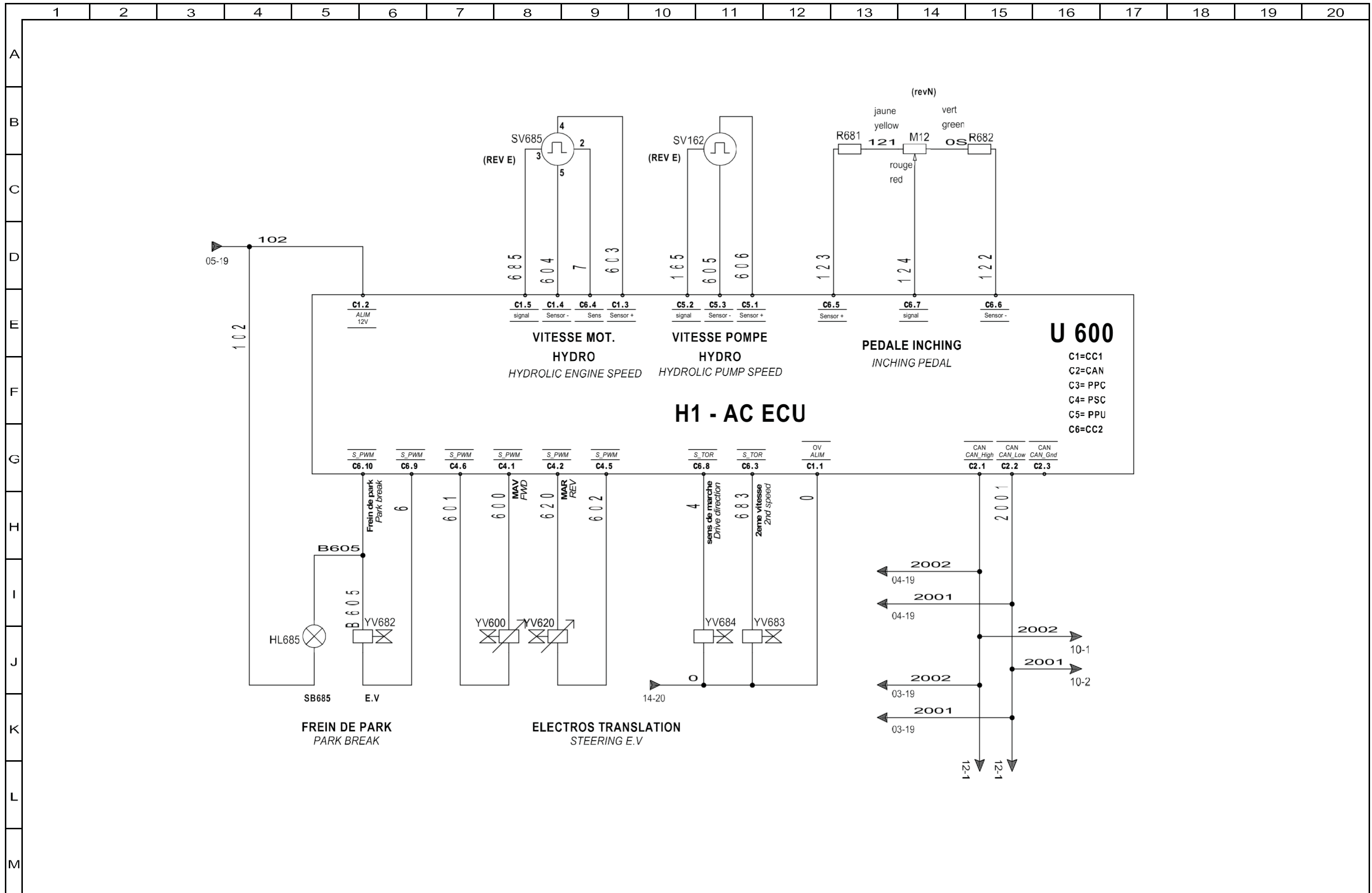

1.9 - FOLIO 9/16

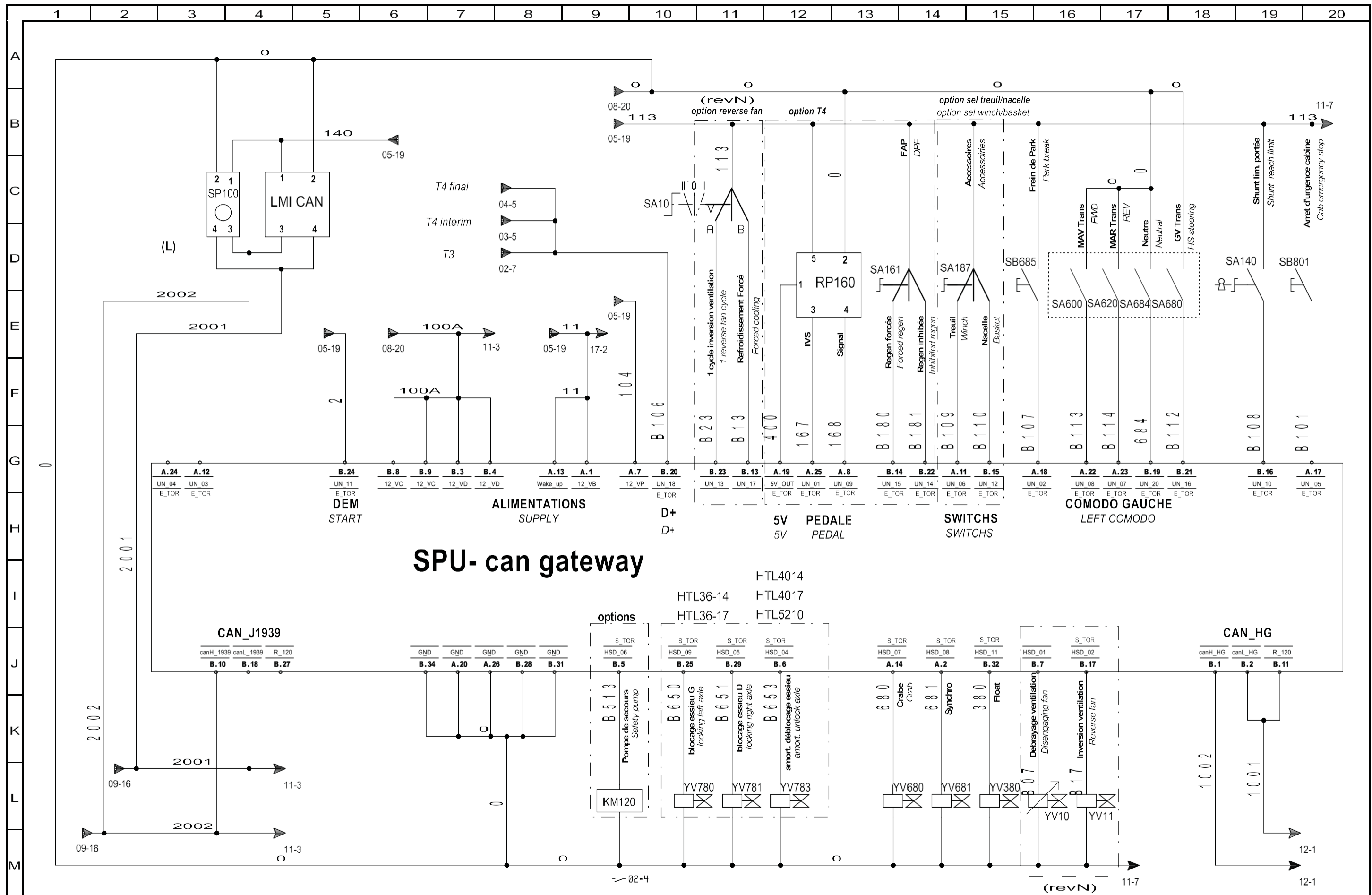

### 1.10 - FOLIO 10/16

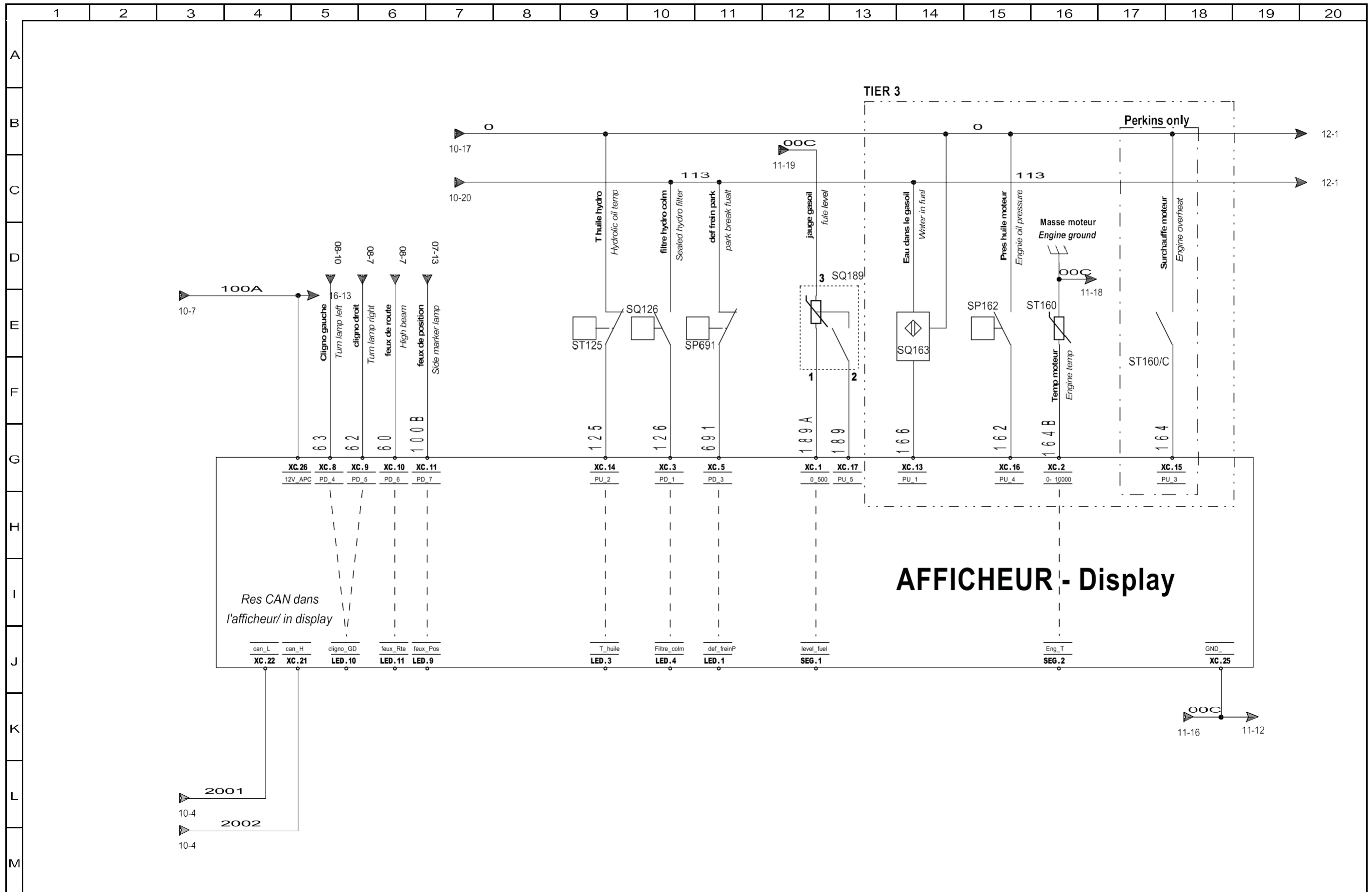

### 1.11 - FOLIO 11/16

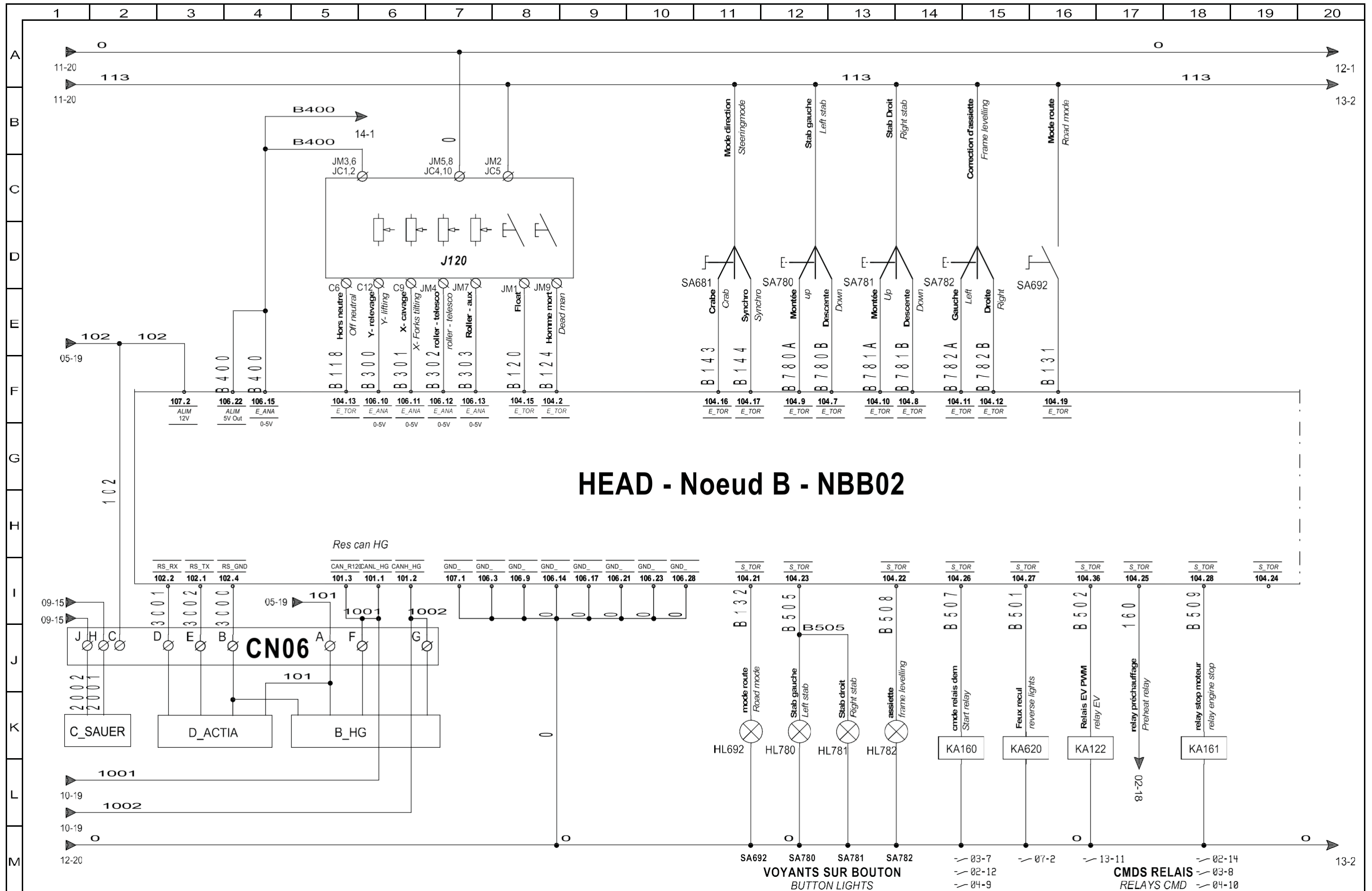



### 1.13 - FOLIO 13/16

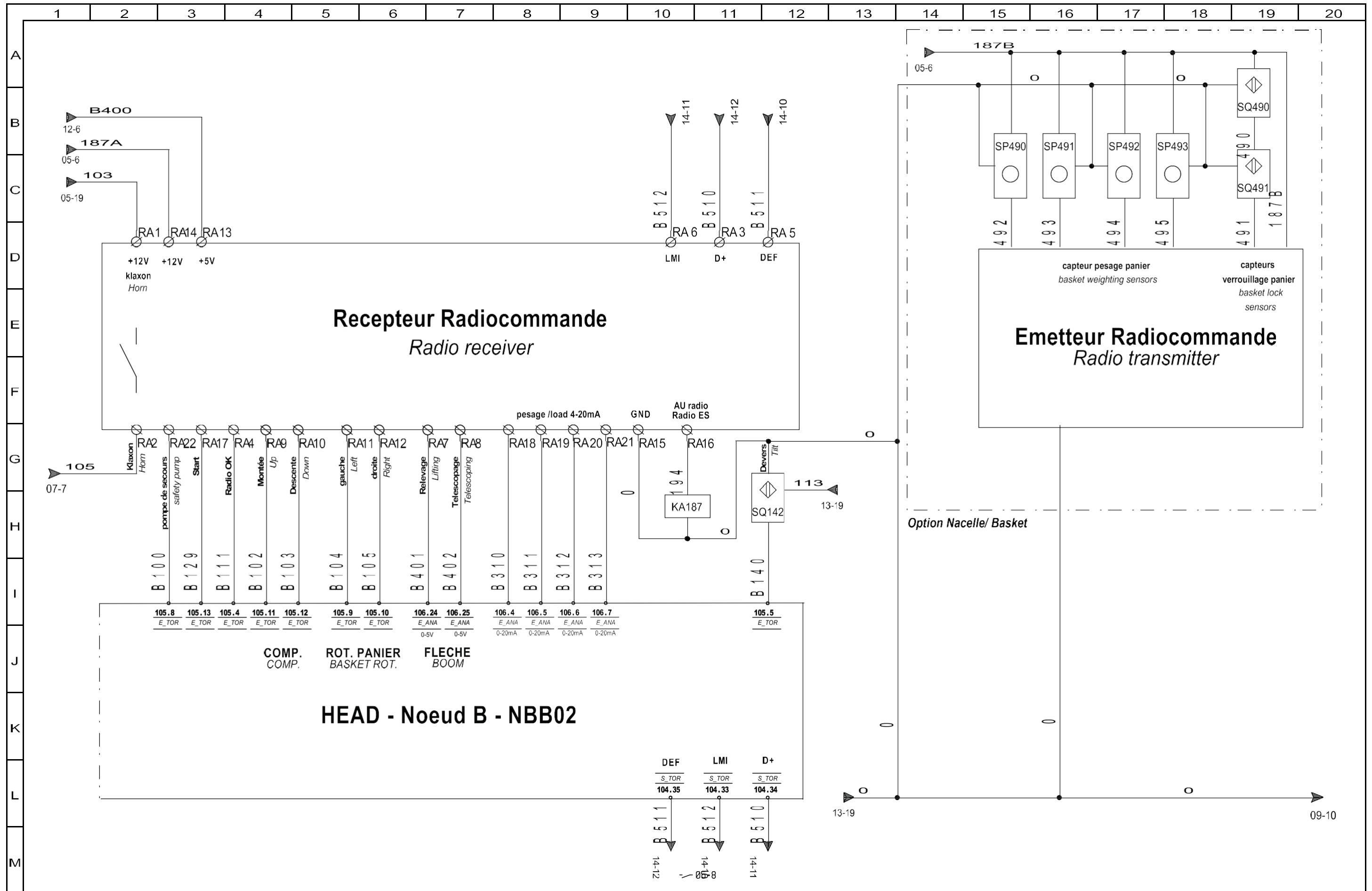

### 1.14 - FOLIO 14/16

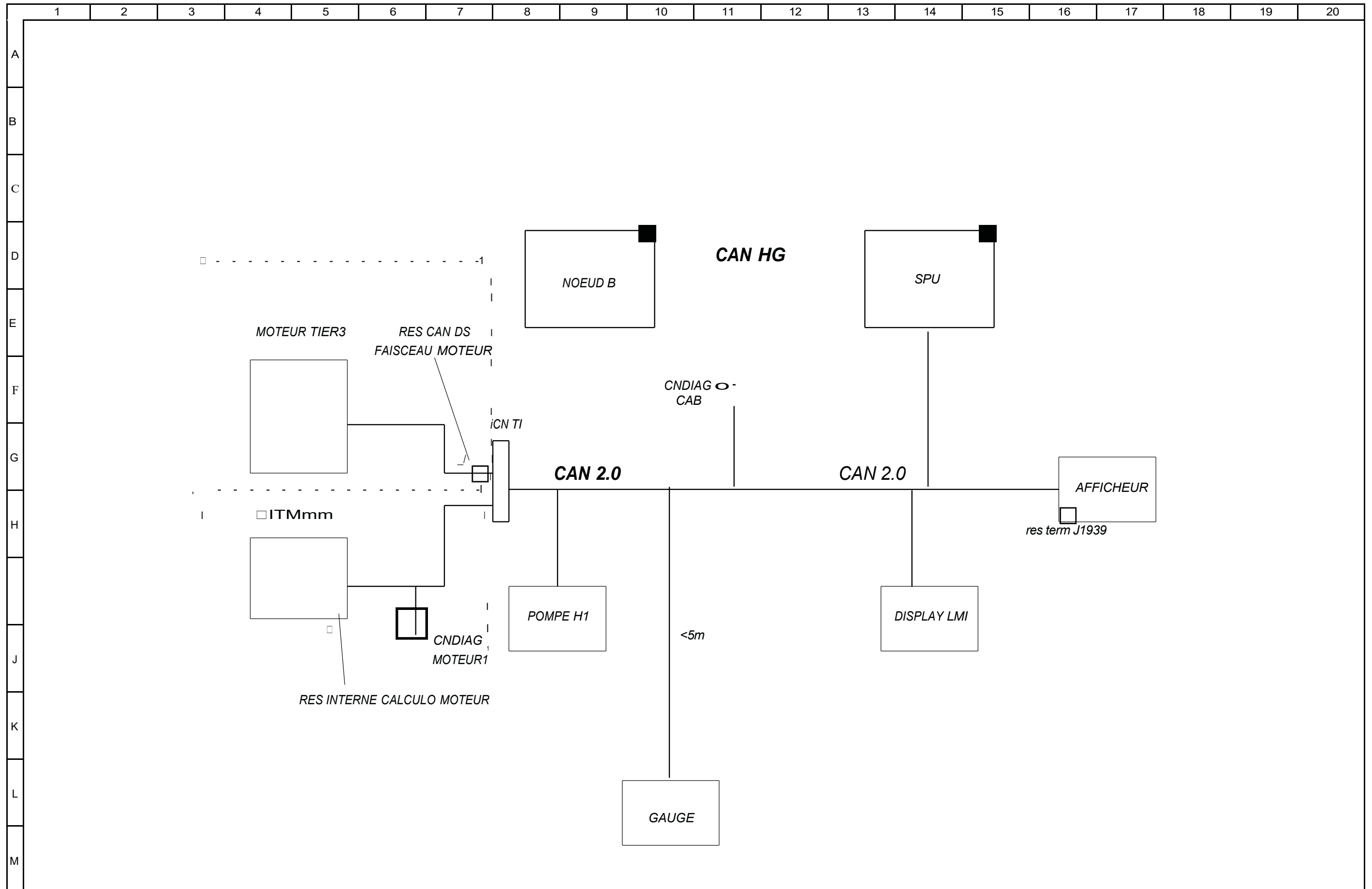

### 1.15 - FOLIO 15/16

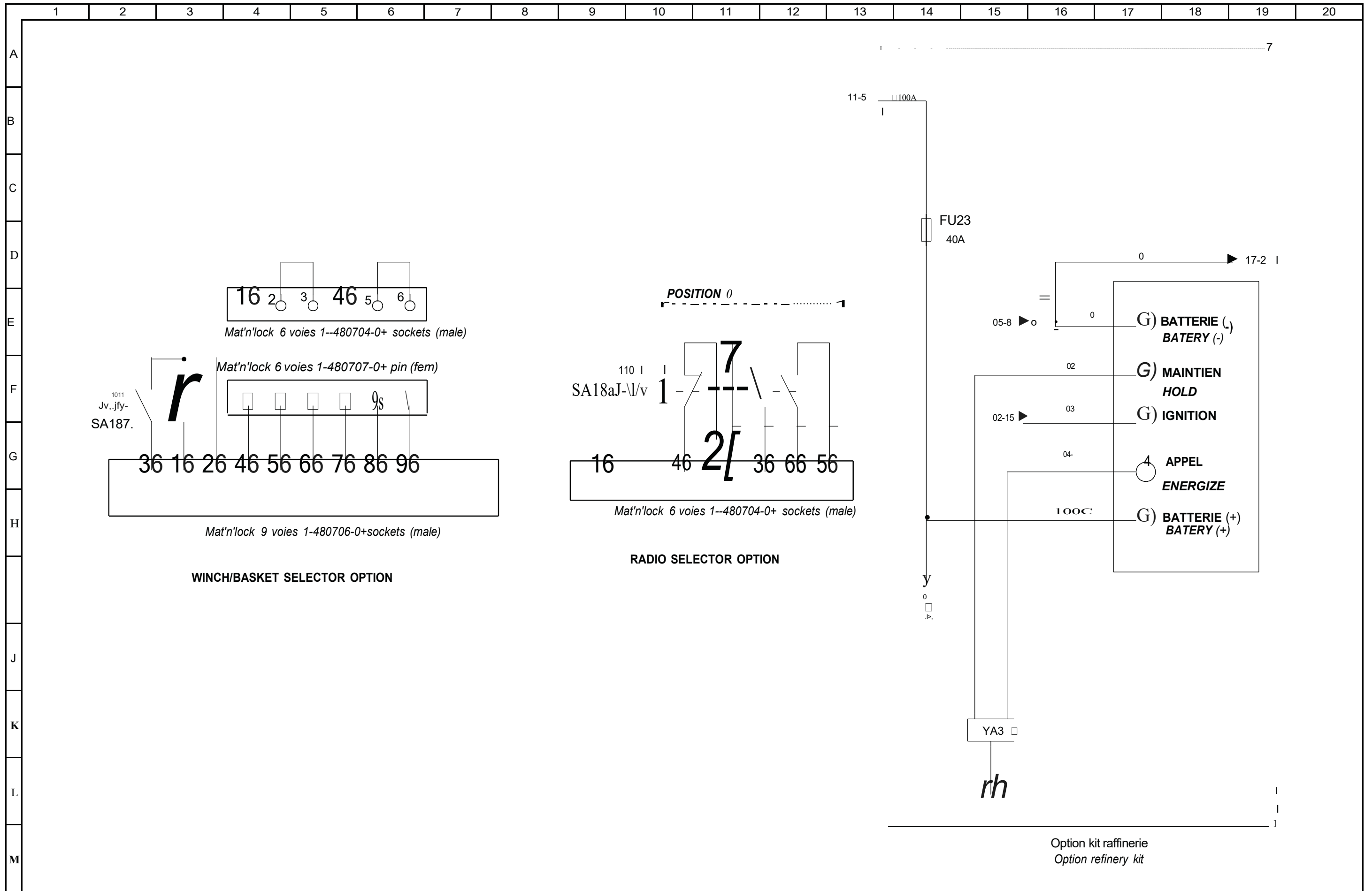

### 1.16 - FOLIO 16/16

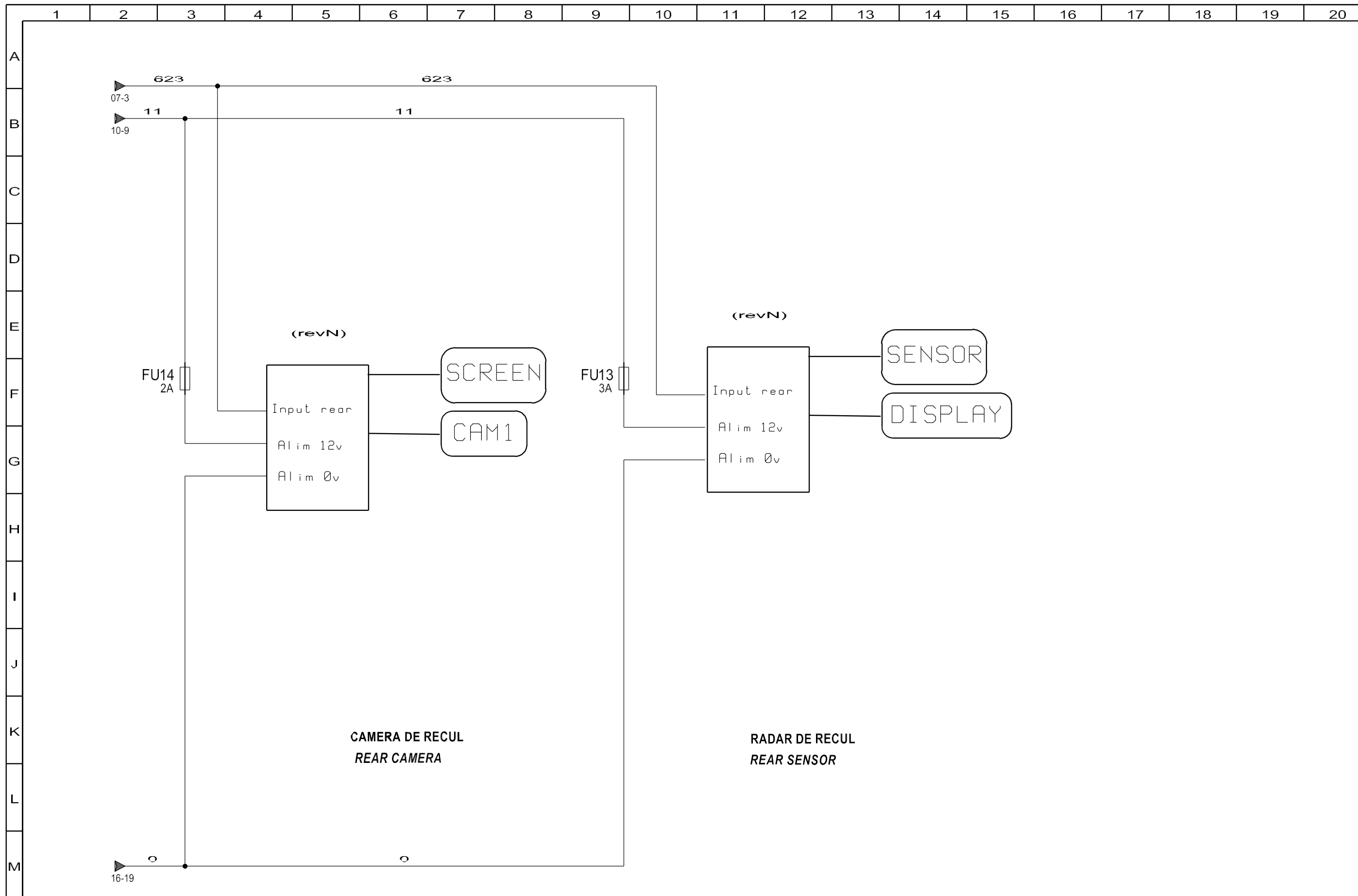

# 1 - HTL 3614 - HTL 8045 - HTL 3617 - HTL 8055 - HTL 4014 - HTL 9045 - HTL 4017 - HTL 9055

### 1.1 - FOLIO 1/2

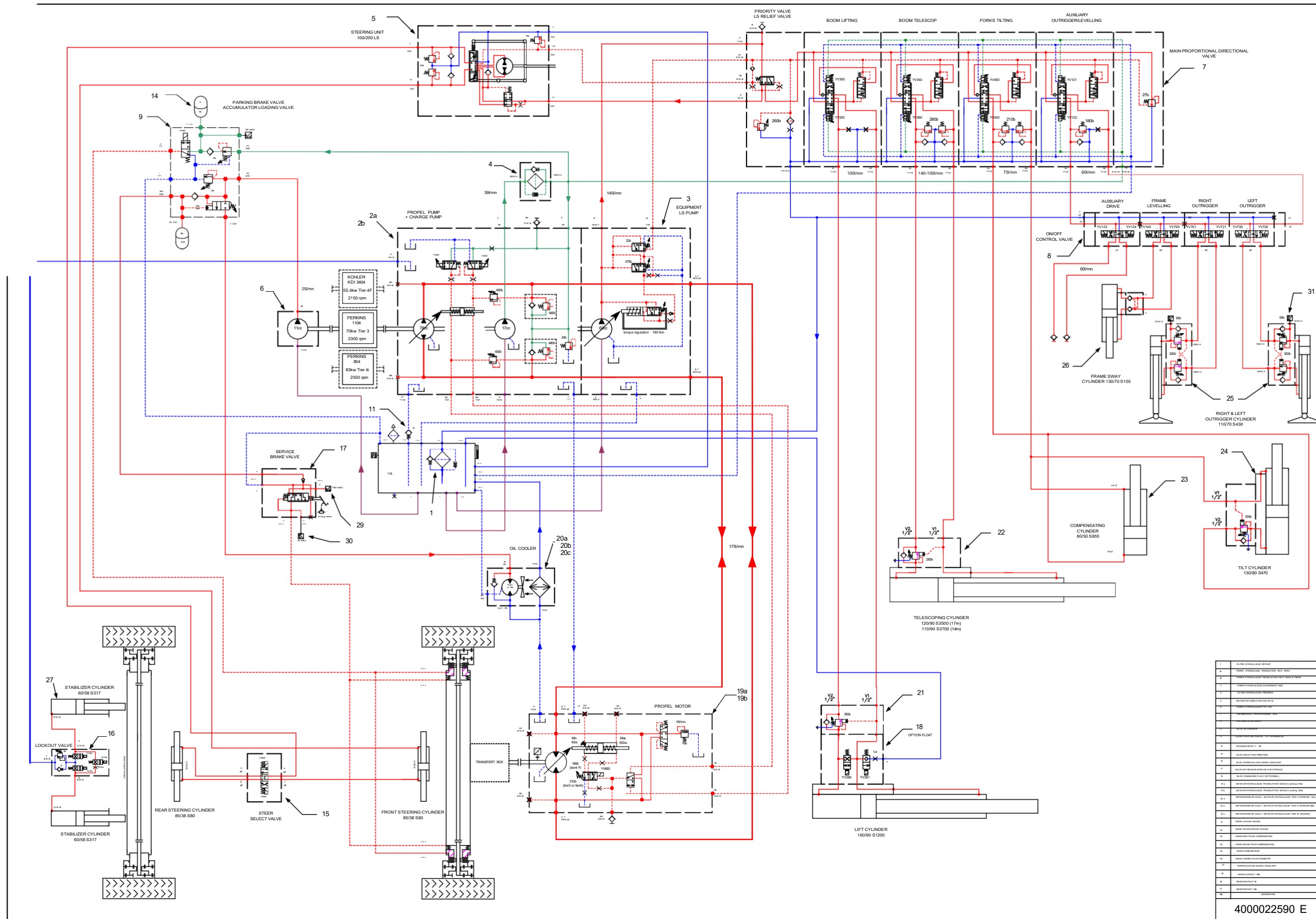

1	MAIN PROPORTIONAL DIRECTIONAL VALVE
2	PROPEL MOTOR
3	EQUIPMENT LS PUMP
4	PROPEL PUMP + CHARGE PUMP
5	STEERING UNIT 100/200 LS
6	PERNS 1104
7	MAIN PROPORTIONAL DIRECTIONAL VALVE
8	ON/OFF CONTROL VALVE
9	PARKING BRAKE VALVE ACCUMULATOR/LOADING VALVE
10	PERNS 854
11	PERNS 1104
12	PERNS 854
13	PERNS 1104
14	PARKING BRAKE VALVE ACCUMULATOR/LOADING VALVE
15	STEER SELECT VALVE
16	LOCKOUT VALVE
17	TELESCOPING CYLINDER 120/90 S3500 (17m) 110/90 S3700 (14m)
18	OPTION FLOAT
19a	PROPEL MOTOR
19b	PROPEL MOTOR
20a	OIL COOLER
20b	OIL COOLER
20c	OIL COOLER
21	LIFT CYLINDER 160/90 S1200
22	TELESCOPING CYLINDER 120/90 S3500 (17m) 110/90 S3700 (14m)
23	COMPENSATING CYLINDER 80/50 S855
24	TILT CYLINDER 130/80 S470
25	RIGHT & LEFT OUTRIGGER CYLINDER 110/70 S430
26	FRAME SWAY CYLINDER 130/70 S155
27	STABILIZER CYLINDER 60/58 S317

4000022590 E

### 1.2 - FOLIO 2/2

