

**HA20RTJ - HA20RTJ O - HA20RTJ PRO - HA61RTJ O - HA61RTJ PRO**

**Operator's manual**

**HA20RTJ - HA20RTJ O - HA20RTJ PRO**

**HA61RTJ O - HA61RTJ PRO**

4000388880

E 02 16

US / GB





# A

## FOREWORD

- 1 - User responsibility . . . . . 8**
  - 1.1- Owner's responsibility . . . . . 8
  - 1.2- Employer's responsibility . . . . . 8
  - 1.3- Trainer's responsibility . . . . . 8
  - 1.4- Operator's responsibility . . . . . 8
- 2 - Safety . . . . . 9**
  - 2.1- Safety instructions . . . . . 9
    - 2.1.1 - Misuse Hazards . . . . . 9
    - 2.1.2 - Falling Hazards . . . . . 9
    - 2.1.3 - Overturning / Tip-over Hazards . . . . . 11
    - 2.1.4 - Electrocution Hazards . . . . . 14
    - 2.1.5 - Explosion / Fire Hazards . . . . . 15
    - 2.1.6 - Crushing / Collision Hazards . . . . . 15
    - 2.1.7 - Uncontrolled movement Hazards . . . . . 16
- 3 - Safety inquiries . . . . . 17**
- 4 - Incident notification . . . . . 17**
- 5 - Compliance . . . . . 18**
  - 5.1- Product information . . . . . 18
    - 5.1.1 - Change of Ownership Notification . . . . . 18
    - 5.1.2 - Owner information update form . . . . . 19
  - 5.2- Product specifications . . . . . 20

# B

## FAMILIARIZATION

- 1 - General safety . . . . . 21**
  - 1.1- Intended use . . . . . 21
  - 1.2- Decal content . . . . . 22
  - 1.3- Symbols and colors . . . . . 23
  - 1.4- Level of severity . . . . . 23
  - 1.5- Symbols legend and definitions . . . . . 24
- 2 - Models description . . . . . 25**
- 3 - Primary machine components . . . . . 26**
  - 3.1- Layout . . . . . 26
  - 3.2- Ground control box . . . . . 28
    - 3.2.1 - Layout . . . . . 28
    - 3.2.2 - Display Panel (LED'S 1 - 10) . . . . . 30
  - 3.3- Platform control box . . . . . 32
    - 3.3.1 - Layout . . . . . 32
    - 3.3.2 - Display Panel (LED'S 101 - 117) . . . . . 34
- 4 - Performance Specifications . . . . . 37**
  - 4.1- Technical characteristics . . . . . 37
  - 4.2- Working area / Range of motion . . . . . 43
- 5 - Decals and markings locations . . . . . 44**

# CONTENTS



# C

## PRE-OPERATION INSPECTION

<b>1 - Recommendations</b>	<b>61</b>
<b>2 - Working area assessment</b>	<b>61</b>
<b>3 - Inspection and Functional test</b>	<b>62</b>
3.1- Daily inspection	62
<b>4 - Safety functional checks</b>	<b>66</b>
4.1- E-Stop button check	66
4.2- Activation of controls	67
4.3- Fault detector	67
4.3.1 - Indicators/LED's test	67
4.3.2 - Buzzers test	67
4.4- Automatic engine cut-out	68
4.5- Overload sensing system (if fitted)	68
4.6- Oscillating axles (If equipped)If equipped	68
4.7- Slope warning device	69
4.8- Travel speed limitation	70

# D

## OPERATION INSTRUCTIONS

<b>1 - Operation</b>	<b>71</b>
1.1- Introduction	71
1.2- Operation from the ground control box	71
1.3- Operation from the platform control box	73
1.4- Operation of overriding system from ground control box	73
<b>2 - Ground control box</b>	<b>74</b>
2.1- To start and stop the machine - Diesel engine	74
2.2- To start and stop the machine - Petrol / gas (Propane) Engine	74
2.3- Boom and arm controls	75
<b>3 - Platform control box</b>	<b>76</b>
3.1- To start and stop the machine	76
3.2- Drive and steer control	77
3.3- Boom and arm controls	78
3.4- Additional controls	79
<b>4 - Emergency procedure</b>	<b>80</b>
4.1- In case of power loss	80
4.2- To rescue operator in platform	81
4.3- No power available	82
<b>5 - Transportation</b>	<b>83</b>
5.1- Putting in transport position	83
5.2- Machine layout	84
5.3- Unloading	85
5.4- Towing	86
5.4.1 - Disengaging the drive hubs	86
5.4.2 - Re-engaging the drive hubs	87
5.5- Storage	87
5.6- Lifting operation	88



# CONTENTS

**6 - Cold Weather Recommendations . . . . . 89**

- 6.1- Engine oil . . . . . 89
- 6.2- Hydraulic oil . . . . . 90
- 6.3- Preheating operation . . . . . 90

## E

### GENERAL SPECIFICATIONS

**1 - Machine dimensions . . . . . 91**

**2 - Major component masses . . . . . 93**

**3 - Acoustics and vibrations . . . . . 94**

**4 - Wheel/Tire assembly . . . . . 95**

- 4.1- Technical specifications . . . . . 95
- 4.2- Inspection and maintenance . . . . . 95

**5 - Options . . . . . 98**

- 5.1- On-board generator . . . . . 98
  - 5.1.1- Principle . . . . . 98
  - 5.1.2- Procedure . . . . . 98
- 5.2- Glazier's kit . . . . . 99
  - 5.2.1- Description . . . . . 99
  - 5.2.2- Characteristics . . . . . 99
  - 5.2.3- Safety precautions . . . . . 99
  - 5.2.4- Pre-operation inspection . . . . . 99
  - 5.2.5- Operation . . . . . 100
  - 5.2.6- Assembly / Disassembly . . . . . 101
  - 5.2.7- Specific decals . . . . . 102
- 5.3- Activ' Shield Bar - SECONDARY GUARDING SYSTEM . . . . . 103
  - 5.3.1- Description . . . . . 103
  - 5.3.2- Characteristics . . . . . 103
  - 5.3.3- Safety precautions . . . . . 104
  - 5.3.4- Pre-operation inspection . . . . . 105
  - 5.3.5- Operation . . . . . 107
  - 5.3.6- Specific decals . . . . . 108
- 5.4- Swing Gate . . . . . 109
  - 5.4.1- Description . . . . . 109
  - 5.4.2- Characteristics . . . . . 109
  - 5.4.3- Safety precautions . . . . . 109
  - 5.4.4- Pre-operation inspection . . . . . 109

## F

### MAINTENANCE

**1 - General . . . . . 111**

**2 - Maintenance Schedule . . . . . 112**

**3 - Inspection program . . . . . 113**

- 3.1- General program . . . . . 113
- 3.2- Daily inspection . . . . . 113
- 3.3- Periodic inspection . . . . . 114
- 3.4- Reinforced inspection . . . . . 114
- 3.5- Major inspection . . . . . 114

**4 - Repairs and adjustments . . . . . 115**



# G

## OTHER INFORMATION

- 1 - Warranty disclosure . . . . . 117**
  - 1.1 - After Sales Service . . . . . 117
  - 1.2 - Manufacturer's warranty . . . . . 117
    - 1.2.1 - Warranty acceptance . . . . . 117
    - 1.2.2 - Warranty period . . . . . 117
    - 1.2.3 - Procedure conditions . . . . . 117
    - 1.2.4 - Conditions of warranty . . . . . 118
- 2 - Subsidiary contact information . . . . . 119**



# A - Foreword

You have just purchased a HAULOTTE® product and we would like to thank you for your business.

The Aerial Work Platform is a mechanical device primarily designed and manufactured with the intent to position people with the necessary tools and material to overhead elevated temporary workplaces. All other uses or alterations/modifications to the aerial work platform must be approved by HAULOTTE®.

This manual shall be considered a permanent component of the machine and shall be kept with the aerial work platform in the designated Manual Holder, at all times.

Safe operation of this product can only be assured if you follow the operating instructions contained in this manual. To ensure proper and safe use of this equipment, it is strongly recommended that only trained and authorized personnel operate and maintain the aerial work platform.

We would particularly like to draw your attention to 2 essential points :

- Comply with safety instructions.
- Use the equipment within the specified/published performance limits.

With regard to the designation of our equipment, we stress that this is purely for commercial purposes and not to be confused with the technical specifications. Only the specifications in this manual should be used to study the suitability of the equipment for the intended use.

This operator's manual is specific to the HAULOTTE® products listed on the cover page of this manual.



**Original language and version :**

**Manuals in English and French are the original instructions. Manuals in other languages are translations of the original instructions.**

The operator's manual does not replace the basic training required for equipment operators. HAULOTTE® has compiled this manual to assist in safe and efficient operation of the products covered in the manual.

The manual must be available to all operators and must be kept in a legible condition. Additional copies can be ordered from HAULOTTE Services®.

Stay Safe and keep working with HAULOTTE® !

# A - Foreword

## 1 - User responsibility

### 1.1 - OWNER'S RESPONSIBILITY

The owner (or hirer) has the obligation :

- To inform operators of the instructions contained in the Operator's Manual.
- For applying the local regulations regarding operation of the machine.
- To replace all manuals or decals that are either missing or not legible. Additional copies can be ordered from HAULOTTE Services®.
- To establish a preventive maintenance program in accordance with the manufacturer's recommendations, taking into account the environment and severity of use of the machine.
- To perform periodic inspections in accordance with HAULOTTE® recommendations and local regulations.

All malfunctions and problems identified during the inspection shall be corrected before the aerial work platform is returned to service.

### 1.2 - EMPLOYER'S RESPONSIBILITY

The employer has the obligation :

- To authorize the operator to use the machine.
- To inform and familiarize the operator with the local regulations.

Forbid anyone from operating the machine if :

- Under the influence of drugs, alcohol, etc.
- Subject to fits, loss of motor skills, dizziness, etc.

### 1.3 - TRAINER'S RESPONSIBILITY

The trainer must be qualified to provide training to operators in accordance with applicable local regulations. The training must be given in an obstacle-free area until the trainee is considered competent as defined by the training program undertaken.

### 1.4 - OPERATOR'S RESPONSIBILITY

The operator has the obligation to :

- Read and understand the contents of this manual and familiarize himself with the decals affixed on the machine.
- To inspect the machine before use according to HAULOTTE®'s recommendations..
- To inform the owner (or hirer) if the manual or any decals are missing or are not legible.
- To inform of any malfunctioning of the machine.

The operator shall ensure that frequent inspections were conducted by the owners and the operator may only operate the machine for the purpose intended by the manufacturer.

Only authorized and qualified operators may operate HAULOTTE® machines.

All operators must become familiar with and fully understand the emergency controls and be able to operate the machine in an emergency.

The operator has the obligation to stop using the machine in the event of malfunction or safety problems on the machine or in the work area and report the problem immediately to his/her supervisor.

# A - Foreword

## 2 - Safety

### 2.1 - SAFETY INSTRUCTIONS

#### 2.1.1 - Misuse Hazards

- Do not use the machine for any other purpose than to position people, their tools and material to the overhead/elevated temporary work places.
- Do not use the machine as a crane, material lift or elevator. Only use the machine as it was intended.
- Do not attach overhanging loads when raising or lowering the platform.
- Do not tie the boom or platform to an adjacent fixed or mobile structure.
- Do not use/operate the machine when alone. A survey person or immediate Supervisor must be present on the ground in case of emergency.
- Do not use a faulty or poorly maintained machine. Remove defective/damaged machine from service.
- Do not climb onto the compartment covers of the machine.
- Do not replace items critical to machine stability with items of different weight or specification.
- Do not replace factory-installed tires with tires of different specifications or ply rating.
- Do not alter or disable machine components that in any way affect safety and stability.
- Do not disable the safety devices.



#### 2.1.2 - Falling Hazards

##### To enter or exit from the platform :

- The machine must be completely stowed.
- Face the machine to access the entry opening to the platform.
- Keep 3 points of contact (both hands and a foot) on the steps and the guardrail.



##### Before commencing operation :

- Ensure that guard rails are correctly installed and secured.
- Ensure that gate or sliding bar is in it's proper closed position.
- Remove oil or grease from the steps, floor, handrail and the guardrails.
- Clear the platform floor free of debris.



# A - Foreword

## When in the platform :

- Occupants must wear a harness in accordance with governmental regulations. Use a fall restraint harness adjusted to your size that has been inspected by a competent person.
- The correct use of the harness requires the lanyard to be connected to an anchorage point designated by the decals. Refer to this decal located on the platform.
- Hold on securely to the guardrails.
- Always keep your feet firmly on the floor of the platform.
- Do not sit, stand, or climb on the platform guard rails.
- Work only within the platform guardrails area and do not lean over guardrails to perform work.
- Do not exit the platform until it is in the completely stowed position.
- Do not use the guardrail as a means of access to climb in or out of the platform.



# A - Foreword

## 2.1.3 - Overturning / Tip-over Hazards

Before positioning and operating the machine :

- Ensure that the surface is capable of supporting the machine weight including the rated capacity.
- Do not exceed the maximum rated capacity that includes the weight of both material and allowed number of occupants. Do not exceed the allowable number of occupants.
- Place the loads uniformly distributed on the platform floor.
- Do not increase the working height (using extensions, ladder, etc.).
- Do not place ladders or scaffolds in the platform or against any part of this machine.
- Do not use the machine in winds exceeding the permissible limit.
- Do not increase the surface area of the platform exposed to wind. This includes adding panels, mesh, banners. Be aware when working with materials with a large surface area. This will add to the wind load on the machine.
- Do not raise the platform or drive with platform elevated on an incline exceeding the rated slope for the machine.
- Do not drive the machine on slopes or grades exceeding the specified limits.
- Do not replace components critical to stability with components of different weight or specification.
- Do not use the machine with material or objects hanging from the guardrail or the boom.
- Do not pull or push towards any object outside of the platform. Do not exceed the maximum allowable side force stated in the performance specifications.
- Do not use the machine to support any external structure.
- Do not use the machine to tow other machines or to drag materials.



A

B

C

D

E

F

G

H

I

# A - Foreword

## Using a machine on a slope :

### **Gradeability :**

- Driving in stowed position UP or DOWN a slope.

### **Rated slope :**

- Operating with platform elevated.



Do not exceed the slope limit for each operation.  Section B 4.1 Technical specifications.

### • **If the tilt alarm sounds with the platform uphill :**

- Lower the upper boom.
- Lower the top arm.
- Retract the upper boom.

### • **If the tilt alarm sounds with the platform facing downhill : .**

- Retract the upper boom.
- Lower the top arm.
- Lower the upper boom.

• While driving, always place the boom above the rear axle, in the direction of movement.

### • **While driving on a slope:**

- Always orientate the machine in the direction of the slope.
- Always place the boom and the arms in fully retracted and in stowed position.
- Do not travel down slopes in high speed.
- Do not drive fast in narrow or cluttered areas. Keep speed under control while making turns or sharp bends.

**WIND :** The aerial work platform can operate up to a maximum wind speed as indicated in the specifications. To identify the local wind speed, use the Beaufort scale below, use a wind gauge or an anemometer.

# A - Foreword

***N.B.-:-THE BEAUFORT SCALE OF WIND FORCE IS ACCEPTED INTERNATIONALLY AND IS USED WHEN COMMUNICATING WEATHER CONDITIONS. A WIND SPEED RANGE AT 10 M (32 FT 9 IN) ABOVE FLAT, CLEAR LAND IS ASSOCIATED WITH EACH DEGREE.***

## Beaufort scale

Force	Meteorological description	Observed effects	m/s	km/h	mph
0	Calm	Smoke rises vertically.	0 - 0,2	0 - 1	0 - 0,62
1	Very light breeze	Smoke indicates the wind direction.	0,3 - 1,5	1 - 5	0,62 - 3,11
2	Light breeze	Wind felt on the face. Leaves rustle. Weather vanes turn.	1,6 - 3,3	6 - 11	3,72 - 6,84
3	Slight breeze	Leaves and small twigs in constant motion. Flags move slightly.	3,4 - 5,4	12 - 19	7,46 - 11,8
4	Nice breeze	Raised dust and loose papers. Small branches are moved.	5,5 - 7,9	20 - 28	12,43 - 17,4
5	Nice breeze	Small trees in leaf to sway. Crested wavelets form on inland waterways.	8,0 - 10,7	29 - 38	18,02 - 23,6
6	Cool wind	Large branches in motion. Power lines and chimneys 'sing'. Umbrellas used with difficulty.	10,8 - 13,8	39 - 49	24,23 - 30,45
7	Near gale	Whole trees in motion. Inconvenience felt when walking against wind.	13,9 - 17,1	50 - 61	31 - 37,9
8	Squall	Some branches break. Generally we cannot walk against the wind.	17,2 - 20,7	62 - 74	38,53 - 45,98
9	Strong squall	The wind causes slight damage to buildings. Tiles and chimney stacks are blown off.	20,8 - 24,4	75 - 88	46,60 - 54,68

# A - Foreword

## 2.1.4 - Electrocution Hazards

The machine is not electrically insulated and does not provide protection from contact or proximity to electrically charged conductors.

Always position the lift at a safe distance from electrically charged conductors to ensure that no part of the machine is within an unsafe area.

Respect the local rules and the minimum safety distance from power lines.

### Minimum safe approach distances

Electric voltage	Minimum safety distance	
	Mètre	Feet
0 - 300 V	Avoid contact	
300 V - 50 kV	3	10
50 - 200 kV	5	15
200 - 350 kV	6	20
350 - 500 kV	8	25
500 - 750 kV	11	35
750 - 1000 kV	14	45

***N.B.-:USE THIS TABLE EXCEPT WHERE LOCAL REGULATIONS INDICATE OTHERWISE.***

- Do not operate the machine when close to live power lines, consider the movement of the machine and the sway of the electric power lines particularly in windy conditions.
- Do not operate the machine during lightning, thunderstorms, snow/ice or any weather condition that could compromise operator safety.
- Do not use the machine as a ground for welding.
- Do not weld on the machine without first disconnecting the battery terminals.
- Always disconnect ground cable first.
- The machine must not be used while charging the batteries.
- When using the platform AC power line, ensure it is protected with a circuit breaker.

Keep away from the machine if it contacts energized power lines. Personnel on the ground or in the platform must not touch or operate the machine until energized power lines are shut off.



# A - Foreword

## 2.1.5 - Explosion / Fire Hazards

Always wear protective clothing and eye wear when working with batteries and power sources/systems.

**N.B.-:ACID IS NEUTRALIZED WITH SODIUM BICARBONATE AND WATER.**

- Do not start the engine if you smell or detect liquid propane gas (LPG), gasoline, diesel fuel or other explosive substances.
- Do not work on or operate a machine in an explosive or flammable atmosphere / environment.
- Do not touch hot components.
- Do not bridge the battery terminals with metallic objects.
- Do not service the battery in proximity of spark, open flame, lit cigarettes.
- Do not fill up the fuel tank, when the engine is running and/or near a flame.



## 2.1.6 - Crushing / Collision Hazards

When in the platform :

- Check the work area for overhead clearance, for any obstacles besides and below the platform when raising/lowering the platform and or before driving.
- During movement, keep all the parts of the body inside the platform. Hold onto the guardrails on the opposite side to any surrounding structures. Take care to avoid trapping hands whilst holding the guardrails.
- To position machine close to a building/structure, it is recommended using the upper boom and or arms movement control functions to position, rather than driving machine closer to structure.
- Always cordon off the area around the base of the machine to keep personnel and other equipment away from the machine while in use.
- Warn personnel not to work, stand, or walk under a raised boom/platform.
- Do not drive in reverse direction (opposite the field of vision).
- Be aware of the boom position and tail swing when rotating the turret (turntable).
- Always ensure that the chassis is never driven any closer than 1 m (3 ft 3 in) to holes, bumps, slopes, obstructions, debris and ground coverings that may hide holes and other dangers.
- Keep non-operating personnel at least 5 m (16 ft 5 in) away from the machine when driving and slewing.

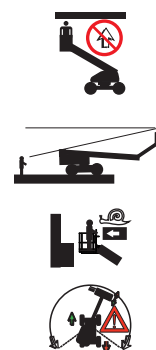

# A - Foreword

- Be aware of driving direction.
  - When turret is slewed/rotated 180°, the platform is now facing the rear of the machine.
  - Check the driving direction with the help of the red or green arrow on the chassis relative to the red and green arrows on the platform control box.
  - Also note that when changing the driving direction (Forward <> Reverse) the joysticks or switches must return to the neutral position before reversing the drive direction and for movement to occur.
- When driving, position the platform so as to provide the best possible visibility and to avoid any blind spots.
- Hold on securely to the guardrails.
- Occupants must wear a harness in accordance with governmental regulations. Use a fall restraint harness adjusted to your size that has been inspected by a competent person.
- Lanyard must be attached to the designated anchorage point.
- Avoid contact with fixed or mobile obstacles (other machines).
- Other machines (crane, aerial work platform, etc.) operating in the work area increase the risk of crushing or collision. Restrict the operation of machines moving within the aerial work platform work area.
- Take into consideration the stopping distance, reduced visibility and blind spots of the machine.
- Limit travel speed to suit the ground surface condition, slope (incline), and people in the vicinity.

## 2.1.7 - Uncontrolled movement Hazards

Do not use a damaged or malfunctioning machine.

Be aware of uncontrolled movement and always respect the following :

- Maintain clearance from high voltage lines.
- Maintain clearance from generators, radar, electromagnetic fields.
- Never expose the batteries or electrical components to water (high pressure washer, rain).
- Never tow the machine over extended distances.
- In case of a machine breakdown, it is possible to tow short distance to load it onto a trailer.
- Never leave the hydraulic cylinders fully extended before switching off the machine, or when stationary for an extended period of time.
- Retract the boom and lower the arms to the stowed position.
- Rotate the turntable so that the boom is between the non-steering wheels.
- Select a safe parking location, on a firm level surface, clear of obstruction and traffic.
- Ensure all compartments are closed and secured.
- Chock the wheels.

# A - Foreword

## 3 - Safety inquiries

Inquiries relating to design criteria/specifications of a product, standards compliance, or overall machine safety should be sent to the HAULOTTE® PRODUCT SAFETY department.

Each inquiry or request should include all relevant information; including contact name, telephone number, mailing address, email address, plus the machine model and serial number.

The HAULOTTE® Product Safety department will evaluate each request/inquiry and will provide a written response.

## 4 - Incident notification

Notify HAULOTTE® immediately when a HAULOTTE® product has been involved in an incident/accident leading to personal injury or death, or when there is a major property damage.

HAULOTTE Group - EUROPE Product Safety Department  Address : La Péronnière - BP 9 - 42152 L'Horme - France  Tel : +33 (0)4 77 29 24 24  Email : ProductSafety@haulotte.com	HAULOTTE Group - Australia, India and Asia Product Safety Department  Address : 46 Green Road - VIC 3175 - Dandenong - Australia  Tel : +61 3 9792 1000  Email : ProductSafety@haulotte.com	HAULOTTE Group - North & South America Product Safety Department  Address : 125 Taylor Parkway, Archbold, OH 43502 - United States  Tel : +1 419 445 8915  Email : ProductSafety@haulotte.com
--	---	---

# A - Foreword

## 5 - Compliance

### 5.1 - PRODUCT INFORMATION

Without the written permission from Haulotte, modifying a HAULOTTE® product is a Safety concern. Any modification may violate Haulotte design parameters, government regulations and industry standards.

If you desire a modification to the product, submit a request in writing to HAULOTTE®.

With the utmost care to ensure enhanced reliability and greater safety of the HAULOTTE® products, it is pertinent that when a "Service or Safety Bulletin" is issued, action is taken immediately. Once the bulletin has been addressed, make sure that the completed form is submitted to HAULOTTE®.

Do not hesitate to contact HAULOTTE Services®, should you have any questions relating to the issued bulletin(s) or with questions on the policy itself.

#### 5.1.1 - Change of Ownership Notification

It is important and necessary to keep HAULOTTE Services® updated with current ownership of the machine. This way, HAULOTTE® will be able to provide the necessary support for the product. If you have sold or transferred this machine(s); it is your responsibility to notify HAULOTTE Services®. It is not required to include Lessees/Renters of Leased/Rented machines on this form.

Use the HAULOTTE® Product Status Notification form to report scrapped, stolen, missing or recovered machine(s).

# A - Foreword

## 5.1.2 - Owner information update form

### Owner information update form

Complete this form and mail or fax it to :

HAULOTTE® subsidiary Name :

Address 1 :

Fax :

Address 2 :

e.mail address :

Address 3 :

### Product information :

Model :

Machine serial number :

Owner / Servicing information : Do not include leased or rented units in this form

Current product owner 1 :

Current product owner 2 :

Name :

Name :

Company :

Company :

Address 1 :

Address 1 :

Address 2 :

Address 2 :

Country :

Country :

Phone :

Phone :

Date of ownership :

Date of ownership :

Signature :

Signature :

Date :

Date :

Company stamp is mandatory :

Company stamp is mandatory :

Tick here if the machine has been permanently removed from service (scrapped). The manufacturer's nameplate must be removed and returned to HAULOTTE Group when the unit is removed from service.

Reason for removal :

# A - Foreword

## 5.2 - PRODUCT SPECIFICATIONS

HAULOTTE® cannot be held liable for any changes to the technical characteristics/specifications contained in this manual. HAULOTTE® has a continuous improvement policy in place for its product range; given this policy, the Company reserves the right to modify their products technical characteristics / specifications without notice.

Certain options can modify the machine's operating characteristics and its' associated safety. If your machine was originally delivered with options fitted, replacing a safety component associated with a particular option does not require any particular precaution other than those associated with the installation itself (static test)

Otherwise, it is essential to follow the manufacturer's recommendations as stated below :

- Installation by authorised HAULOTTE® personnel only.
- Update the manufacturer's identification plate.
- Have stability tests carried out by a certified agency/competent person.
- Ensure decals are updated.

# B - Familiarization

## 1 - General safety

### 1.1 - INTENDED USE

To ensure the safe use of an Aerial Work Platform, support personnel must always be available on the ground. If necessary, support personnel will be required to operate the emergency functions of the machine and in rescuing the operator.

Do not operate the product in the following situations :

- On soft, unstable or cluttered ground.
- With wind blowing faster than the permissible limit.
  - Check the allowable wind speed specified in the performance specifications tabulation.
  - Consult the Beaufort scale.
- Close to power lines. Keep a safe distance.
- Outside of the temperature range -20°C / + 50°C (-4°F / +122°F).
- In an explosive atmosphere / environment.
- During storms.
- In the presence of strong electromagnetic fields.

***N.B.-:USE THE MACHINE UNDER "NORMAL" CLIMATIC CONDITIONS. IF YOU NEED TO USE THE MACHINE IN CLIMATIC CONDITIONS LIKELY TO CAUSE DETERIORATION (EXTREME : HUMIDITY, TEMPERATURES, SALINITY, CORROSIVENESS, ATMOSPHERIC PRESSURE), CONTACT HAULOTTE SERVICES®. REDUCE INTERVALS BETWEEN SERVICING.***

***N.B.-:WHILE THE MACHINE IS NOT IN USE, CARE MUST BE TAKEN TO BRING THE MACHINE TO THE FULLY STOWED POSITION. ENSURE THAT THE MACHINE IS LOCKED IN A SECURE LOCATION, AND THE CONTROL KEY IS REMOVED TO PREVENT UNAUTHORISED USE OF THE MACHINE.***

# B - Familiarization

## 1.2 - DECAL CONTENT

Decals are provided to alert the user of hazards inherent with the Aerial Work Platforms.

Decals provide the following information :

- The level of severity.
- The specific hazard.
- A method to avoid, suppress or reduce the hazard.
- Descriptive text (where required).

Familiarize yourself with the decals and the hazard severity levels.

### CE and AS standards



### ANSI and CSA standards

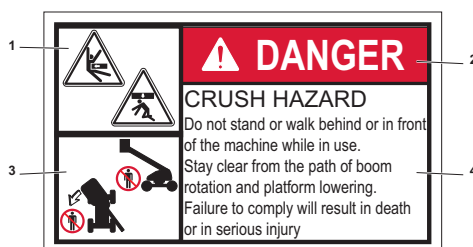

Marking	Description
1	Hazard symbol
2	Level of severity
3	Avoidance symbol pictorial
4	Avoidance text

Decals must be kept in good legible condition.

Familiarize yourself with the decals and their respective color codes.







Additional decals can be ordered from HAULOTTE Services®.

# B - Familiarization











## 1.3 - SYMBOLS AND COLORS

Symbols and colors are used to alert the operator of safety precautions and/or to highlight important safety information.

The following safety symbols are used throughout this manual to indicate specific hazards and the hazard severity level when operating or maintaining the Aerial Work Platform.

Symbol	Description
	Danger : Risk of injury or death
	Caution : Risk of material damage
	Prohibited action
	Reminder to use good practice or follow pre-operation checks
	Cross-reference to another part of the manual
	Cross-reference to another manual
	Cross-reference to repair (contact HAULOTTE Services®)
N.B. :	Additional technical information

## 1.4 - LEVEL OF SEVERITY

Color	Title	Description
		Danger : Indicates a hazardous situation which if not avoided, WILL result in death or serious injury.
		Warning : Indicates a hazardous situation which if not avoided, COULD result in death or serious injury.
		Caution : Failure to comply could result in minor or moderate injury.
		Notice : Indicates recommended practices if not followed, may result in a malfunction or damage the machine or its components.
		Procedure : Indicates a maintenance operation.

# B - Familiarization

## 1.5 - SYMBOLS LEGEND AND DEFINITIONS

Symbols are used throughout this manual to depict hazards, avoidance measures and indicate when information is required.

Refer to the following table to familiarize yourself with these symbols.

Symbol	Description	Symbol	Description	Symbol	Description
	Body crushing hazard		Foot crushing hazard		High pressure fluid ejection hazard
			Hand crushing hazard		Entanglement hazard
			Health/safety hazards related to chemicals		Health-damaging effects from hot work environment
	Electrical contact or lightning strike		Burns and scalds from contact with flames, explosion or radiation from heat sources		Injury from Electric arcs - Energy supply disconnecting devices - Batteries fire, emissions, etc
	Risk of operator(s) falling		Tip over due to excessive loading / wind load and excessive ground slope		Relate and coordinate directional arrows on the chassis with those on the control box
	Do not put foot in this area		Do not put your hand in this area		Keep away from product working area
	Never expose batteries and electrical component to high pressure washer		Ensure entry drop rail is down		Maintain safe clearance from high voltage electrically charged conductors as described in manual - Do not use in thunderstorms
	Flames prohibited		Safety belt		Overload
	Refer to operator manual		Enable switch		Use appropriate lanyard attached to dedicated anchor point.
	Wheel pressure		Tie down point		Use safety prop before attempting any maintenance work
	Tow point		Lift point		
	Keep away from hot surfaces		Wear protective equipment		

# B - Familiarization

## 2 - Models description

Regulation	Models
ANSI and CSA standards	HA61RTJO
	HA61RTJ PRO
	HA20RTJ
CE and AS standards	HA20RTJO
	HA20RTJ PRO

A

**B**

C

D

E

F

G

H

I

# B - Familiarization

## 3 - Primary machine components

### 3.1 - LAYOUT

HA20RTJ - HA20RTJO - HA20RTJPRO - HA61RTJO - HA61RTJPRO

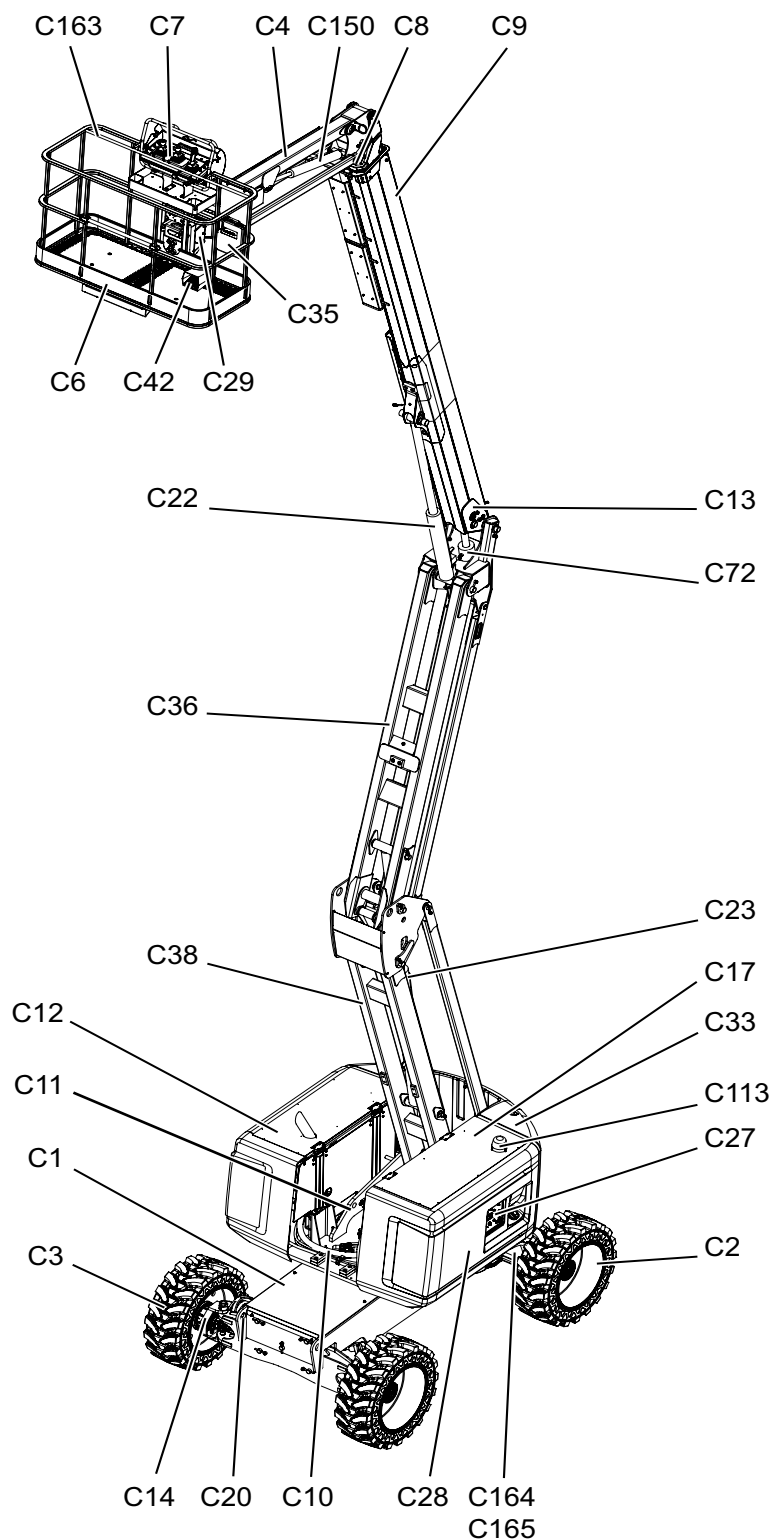

# B - Familiarization

Marking	Description	Marking	Description
C1	Chassis	C22	Boom lift cylinder
C2	Steering wheel	C23	Arm lifting cylinder
C3	Rear drive wheel (and steer wheel if 4WS)	C27	Ground control box
C4	Jib	C28	Tilt sensor
C6	Platform	C29	Platform rotation cylinder
C7	Platform control box	C33	Counterweight
C8	Input jib compensation cylinder	C35	Document holder
C9	Upper boom	C36	Top arm
C10	Slew ring	C38	Bottom arm
C11	Turntable assembly	C42	'Enable Switch' pedal
C12	Right side compartment	C72	Output jib compensation cylinder
C13	Arm/Boom link piece	C113	Beacon light
C14	Hydraulic drive motor and reducer	C150	Jib lifting cylinder
C15	Right side compartment (hydraulic oil tank and fuel tank)	C163	Handrail
C17	Left side compartment (engine, pump and starter battery)	C164	Front steering axle (For HA20RTJ only)
C20	Tie-down (and/or lifting) points	C165	Front steering and oscillating axle (For HA20RTJ O / HA20RTJ PRO / HA61RTJ O / HA61RTJ PRO only)

# B - Familiarization

## 3.2 - GROUND CONTROL BOX

### 3.2.1 - Layout

General view

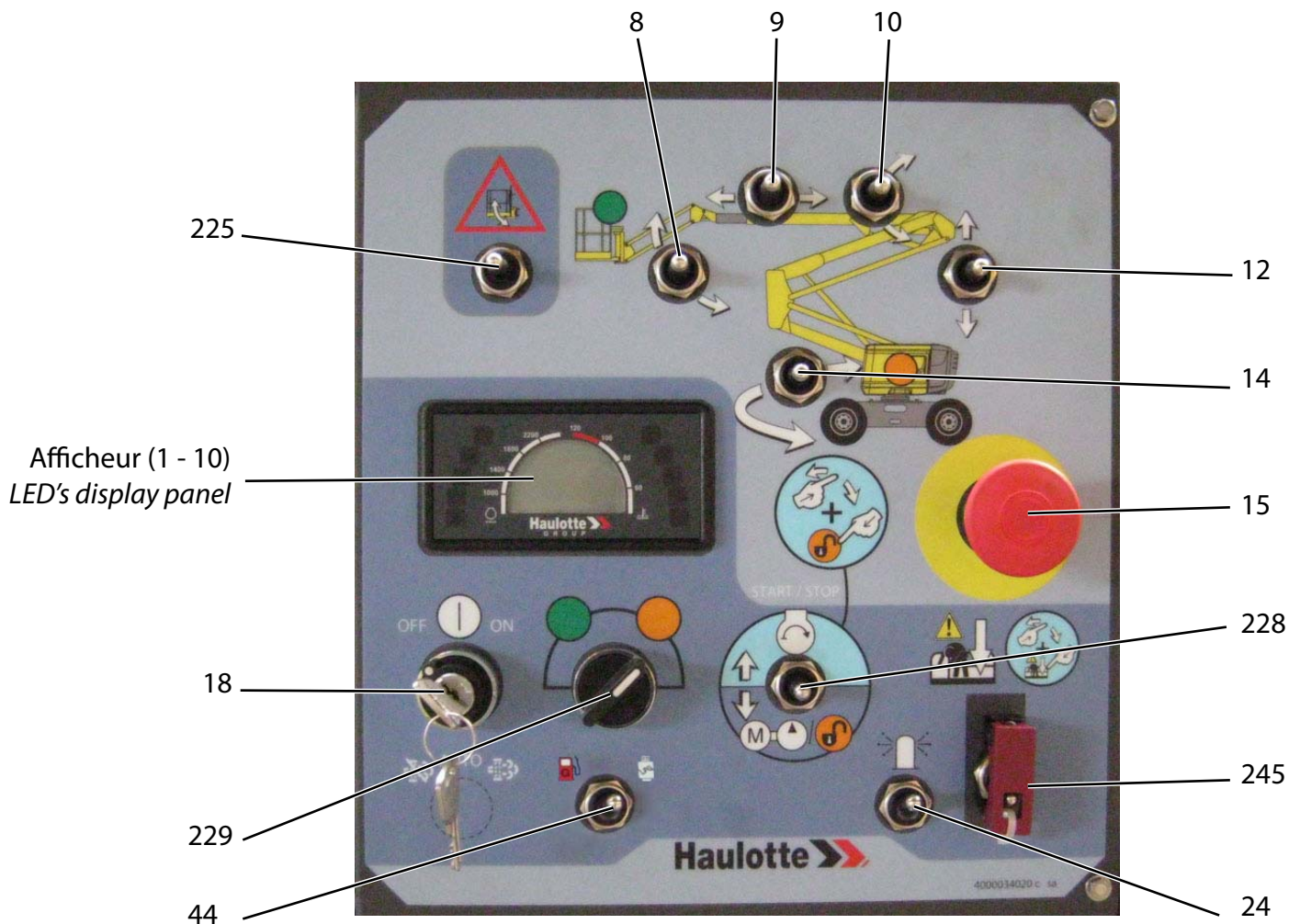

Controls and indicators

Marking	Description	Function
8	Jib lifting / lowering switch <sup>1</sup>	Move upwards : Jib lifting Move downwards : Jib lowering
9	Boom telescoping switch	Move to the left : Boom extension Move to the right : Boom retraction Held down at the same with the boom lifting control ( 10 ) : Reset the maintenance counters to zero once the maintenance operations have been done
10	Boom raising switch	Move upwards : Boom raising Move downwards : Boom lowering Held down at the same time with the boom telescope control ( 9 ) : Reset the maintenance counters to zero once the maintenance operations have been done
12	Arm lifting switch	Move upwards : Arm raises Move downwards : Arm lowering

# B - Familiarization

Marking	Description	Function
14	Turntable rotation switch	Move to the left : Counter clockwise (CCW) rotation Move to the right : Clockwise (CW) rotation
15	E-stop button	Pulled out : E-stop activated Pushed in : De-energizes control system
18	ON/OFF selector key switch	ON : Power turned ON OFF : Power turned OFF
24	Beacon light on/off <sup>2</sup>	Move upwards : Beacon light on Move downwards : Beacon light off
44	Fuel selector <sup>3</sup>	Push switch to the right for LPG (liquid propane gas supply) Push switch to the left for gasoline (petrol) or diesel fuel supply
225	Platform/Jib compensation resetting selector switch	Move upwards and hold : Raising compensation Move downwards and hold : Compensation descent
228	'Enable Switch' selector / Back-up unit selector	Move upwards : Engine start Move downwards : Enable switch. If the engine is switched off, the emergency electropump is engaged automatically.
229	Control box energizing selector	Left : Platform control box energized Right : Ground control box energized
245	"Overriding system" switch under sealed cover	Emergency lowering system enabled when seal is broken and cover is lifted. This must be used ONLY when normal operation from the ground box is unavailable - use in emergencies ONLY.

1. For machines fitted with
2. For machines fitted with
3. For machines fitted with

# B - Familiarization

## 3.2.2 - Display Panel (LED'S 1 - 10)







### Indicators / Cluster



Marking	Description
LED 1	<b>Overriding system :</b> <ul style="list-style-type: none"> <li>• Stays illuminated with Overriding system switch ( 245 ) in use.</li> </ul>
LED 2	<b>Fault :</b> <ul style="list-style-type: none"> <li>• Rapid flashing if a fault is active (current defect)</li> <li>• Flashing if the service counter is at zero</li> </ul>
LED 3	<b>Radius limitation :</b> <ul style="list-style-type: none"> <li>• Not used</li> </ul>
LED 4	<b>Overload (For CE and AS standards only)</b> <ul style="list-style-type: none"> <li>• Flashing : Faulty weighing system</li> <li>• Illuminated in case of overload</li> </ul>
LED 5	<b>Combustion engine pre-heating :</b> <ul style="list-style-type: none"> <li>• Illuminated while engine is pre-heating</li> <li>• Off if engine started and if post-heating</li> </ul>
LED 6	<b>Engine warning :</b> <ul style="list-style-type: none"> <li>• Flashing : 5 flashes when ignition is switched on if service counter is less than 20 hours</li> <li>• Constantly on : If the service counter is at zero</li> </ul>
LED 7	<b>Engine shutdown :</b> <ul style="list-style-type: none"> <li>• Lighted in case of major engine fault (e.g. engine overheating, oil pressure, alternator fault, etc.)</li> <li>• Lighted in case of faults managed by the engine ECU</li> </ul>
LED 8 <sup>1</sup>	<b>DPF regeneration inhibited (DPF : Diesel Particulate Filter)</b>
LED 9 <sup>2</sup>	<b>DPF regeneration required :</b> <ul style="list-style-type: none"> <li>• Permanently lighted if the particle filter requires regeneration with a high clogging level (DPF : Diesel Particulate Filter)</li> </ul>
LED 10 <sup>3</sup>	<b>DPF regeneration in progress, high temperature in the exhaust system ( HEST ) (HEST : High Exhaust System Temperature)</b>

1. If engine quipped with Particulate Filter Regeneration
2. If engine quipped with Particulate Filter Regeneration
3. If engine quipped with Particulate Filter Regeneration

# B - Familiarization

Symbol	Description
	Illuminated when service counter is displayed
	<ul style="list-style-type: none"> <li>• Illuminated when engine is not running or when hour meter is displayed</li> <li>• Flashing engine in operation</li> </ul>
	Low fuel level
	Illuminated when engine is not running, or if the engine is running and there is an alternator fault
	<p>Display of service counter for 3 s when the machine is switched on, then display of the hour meter for 3 s. Then</p> <ol style="list-style-type: none"> <li>1. Display of one or more faults, if present, with scrolling of faults every 2 s</li> <li>2. Display of service counter if it is at zero</li> <li>3. Display of hour meter</li> </ol>
	Indicates the engine speed
	<ul style="list-style-type: none"> <li>• Indicates engine temperature, if available on the engine</li> <li>• All the bars flash if engine overheating</li> </ul>

# B - Familiarization

## 3.3 - PLATFORM CONTROL BOX

### 3.3.1 - Layout

#### General view

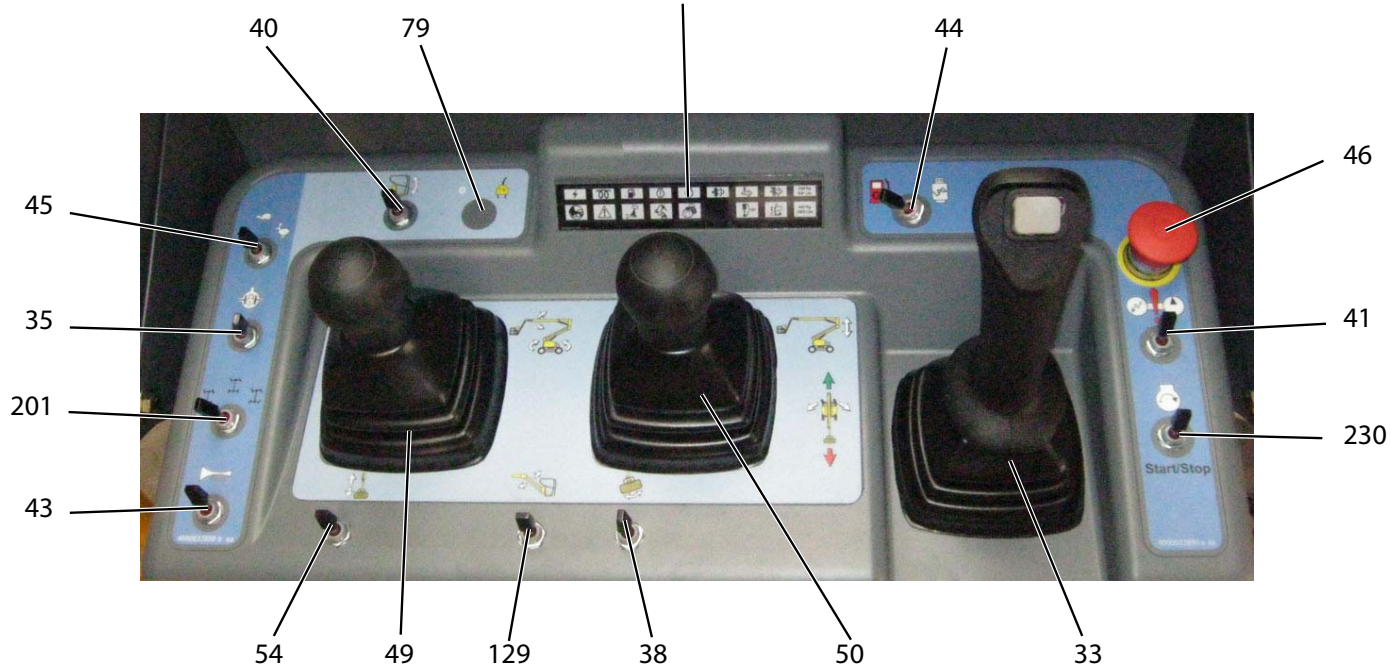

Affichage pupitre de commandes haut (Led 101 - 117)  
Platform control box display (Led's 101 - 117)



#### Controls and indicators

Marking	Description	Function
33	Drive joystick	Move forward : Forward drive Move backwards : Reverse drive
	Steering rocker switch	Press right side of button : Steer right - According to selected mode ( 201 ) Press left side of button : Steer left - According to selected mode ( 201 )
35	Differential lock selector	Toggle left and hold(Activated) : Maximum drive torque (on difficult or sloping ground) Release (deactivated) : Standard torque
38	Platform rotation switch	Move to the right : Counter clockwise (CCW) rotation Move to the left : Clockwise (CW) rotation
40	Platform leveling switch	Move upwards : Raise platform Move downwards : Platform lowers
41	Auxiliary power switch	Toggle and hold : Back-up unit activated Release : Back-up unit deactivated
43	Horn button	Push the horn selector to the right to sound the horn The horn stops when the selector switch is released
44	Fuel selector <sup>1</sup>	Push switch to the right for LPG (liquid propane gas supply) Push switch to the left for gasoline (petrol) or diesel fuel supply

# B - Familiarization

Marking	Description	Function
		 High-speed drive
45	Drive speed selector	 Medium speed drive
		 Low-speed drive
46	E-stop button	Pulled out : Platform control box energized Pressed in : De-energizes control system (Engine stopped)
49	Turntable rotation joystick	Move to the right : Counter clockwise (CCW) rotation Move to the left : Clockwise (CW) rotation
	Boom lift joystick	Move forward : Raise boom Move backwards : Lower boom
50	Arm lift joystick	Move forward : Arm raises Move backwards : Arm lowers
54	Boom telescoping switch	Move upwards : Boom retraction Move downwards : Boom extension
79	Generator selector <sup>2</sup>	Move to the left : Generator deactivated Move to the right : Generator activated
129	Jib lifting/lowering switch <sup>3</sup>	Hold upwards : Lifting Move downwards and hold : Lowering
201	Steering mode selector <sup>4</sup>	2 wheel steering 4 wheel steering - Synchronized axle - Only for PRO model Crab steering - Only for PRO model
230	Engine start-up / stop selector	Start or stop the engine (depending on the machine's operating status) by moving the toggle switch

1. For machines fitted with
2. For machines fitted with
3. For machines fitted with
4. For machines fitted with

# B - Familiarization

## 3.3.2 - Display Panel (LED'S 101 - 117)



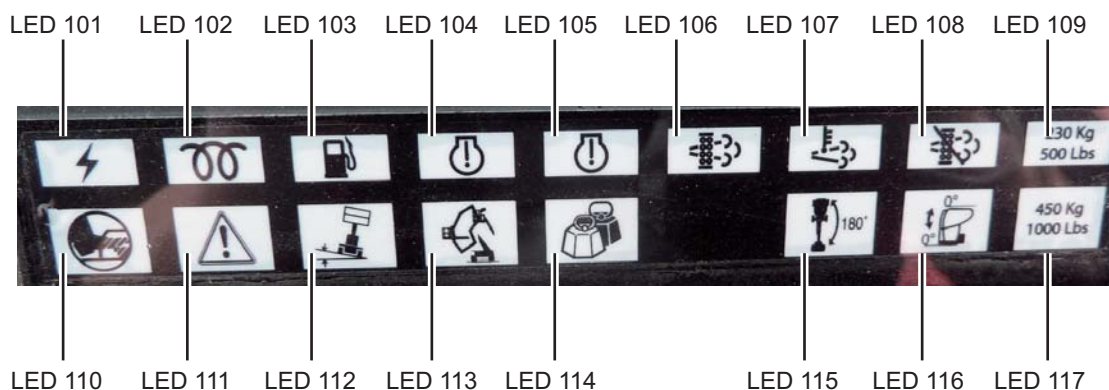









Platform control box display



Marking	Symbol	Function	Marking	Symbol	Function
LED 101		Power ON	LED 110		Foot pedal switch
LED 102		Combustion engine pre-heating	LED 111		Fault
LED 103		Low fuel level	LED 112		Tilt
LED 104		Engine warning	LED 113		Not used
LED 105		Engine shutdown	LED 114		Overload
LED 106		regeneration required(Not used)	LED 115		Turret at 180°(Not used)
LED 107		Regeneration in progress(Not used)	LED 116		Platform leveling
LED 108		DPF disable	LED 117 <sup>1</sup>		Not used
LED 109 <sup>2</sup>		Not used			

1. If machine equipped with dual load  
 2. If machine equipped with dual load

# B - Familiarization

Symbol	Description
	<b>Machine switched on :</b> <ul style="list-style-type: none"> <li>• Rapid flashing : Machine is ON, but platform control panel is not active but the ground control panel is ON. Also flashes with either E-stop pressed in</li> <li>• Illuminated : Machine is turned on and platform control panel is active.</li> </ul>
	<b>Foot pedal switch :</b> <ul style="list-style-type: none"> <li>• Illuminated when foot pedal activated</li> </ul>
	<b>Faults :</b> <ul style="list-style-type: none"> <li>• Rapid flashing : If a fault is active (current fault)</li> </ul>
	<b>Overload (If machine equipped with weighing system) :</b> <ul style="list-style-type: none"> <li>• Rapid flashing : Faulty weighing / overload system</li> <li>• Illuminated when overloaded</li> </ul>
	<b>Tilt sensor (if fitted) :</b> <ul style="list-style-type: none"> <li>• Permanently on in case of tilting, machine folded or unfolded</li> </ul>
	<b>Platform levelling +/- 10° :</b> <ul style="list-style-type: none"> <li>• Illuminated if the angle of the platform reaches +/- 10° in relation to the horizontal and movement control</li> </ul>
	<b>Low fuel level</b>
	<b>Combustion engine pre-heating :</b> <ul style="list-style-type: none"> <li>• Illuminated while engine is pre-heating</li> <li>• Off if engine started and if post-heating</li> </ul>
	<b>Engine warning :</b> <ul style="list-style-type: none"> <li>• Lighted in case of minor engine fault (e.g. water in the diesel, clogged air filter, etc.)</li> <li>• Lighted or flashing in case of fault managed by the engine ECU</li> </ul>
	<b>Engine shutdown :</b> <ul style="list-style-type: none"> <li>• Lighted in case of major engine fault (e.g. engine overheating, oil pressure, alternator fault, etc.)</li> <li>• Lighted in case of faults managed by the engine ECU</li> </ul>
	<b>DPF regeneration required :</b> <ul style="list-style-type: none"> <li>• Permanently lighted if the particle filter requires regeneration with a high clogging level<sup>1</sup></li> </ul>
	<b>DPF regeneration in progress, high temperature in the exhaust system ( HEST ) : <sup>2</sup></b>
	<b>DPF regeneration inhibited<sup>3</sup></b>

1. If engine quipped with Particulate Filter Regeneration
2. If engine quipped with Particulate Filter Regeneration
3. If engine quipped with Particulate Filter Regeneration

# B - Familiarization

Filter status	Level of clogging					
DPF cannot be recovered	> 250%	ON				ON
Manual regeneration required (high level)	250% - 180%	ON				OFF
Automatic or manual regeneration required (medium level -> regeneration deactivation must not be engaged)	180% - 130%	ON			OFF	OFF
Automatic regeneration possible (low level)	130% - 90%	OFF			OFF	OFF
Passive regeneration	< 90%	OFF			OFF	OFF
regeneration inhibited			ON			
Active regeneration (automatic or forced)				ON		

# B - Familiarization

## 4 - Performance Specifications

### 4.1 - TECHNICAL CHARACTERISTICS

Use the table to select the right Haulotte machine for the job.

#### CE and AS standards

Machine	HA20RTJ		HA20RTJ O	
	SI	Imp.	SI	Imp.
<b>Characteristics - Dimensions</b>				
Maximum working height	20,60 m	67 ft 7 in	20,60 m	67 ft 7 in
Maximum platform height	18,60 m	61 ft 0 in	18,60 m	61 ft 0 in
Maximum horizontal reach	12,10 m	39 ft 8 in	12,10 m	39 ft 8 in
Maximum outreach above the ground	11,60 m	38 ft 1 in	11,60 m	38 ft 1 in
Maximum platform height before driving speed restriction	6 m	19 ft 8 in	6 m	19 ft 8 in
Maximum boom articulation point height	8,10 m	26 ft 7 in	8,10 m	26 ft 7 in
Maximum load capacity	230 kg	500 lbs	230 kg	500 lbs
Jib working range	140° (+60° / -80°)			
Basket rotation angle	180° (+ 90° / -90°)			
Boom rotation angle	75°			
Turntable rotation	355° non continuous			
Maximum number of occupants allowed	2			
Maximum wind speed allowed	45 km/h	28 mph	60 km/h	37 mph
Gradeability	45%			
Sideslope	25%			
Maximum rated slope allowed - CE - AS	5°			
Manual force - CE - AS	400 N - 90 lbf			
Maximum load on wheel	4776 daN	10,736 lbs	4960 daN	11,150 lbs
Outside turning radius	4,50 m	14 ft 9 in	4,50 m	14 ft 9 in
Inside turning radius	2,40 m	7 ft 10 in	2,40 m	7 ft 10 in
Maximum ground pressure of wheel on paved ground <sup>1</sup>	12,3 daN/cm <sup>2</sup>	4776 daN	15,3 daN/cm <sup>2</sup>	5940 daN
Total weight	9300 kg	20,507 lbs	9500 kg	20,948 lbs
<b>Drive speed :</b>				
• Low (Machine elevated)	1,2 km/h	0.75 mph	1,2 km/h	0.75 mph
• Medium (Machine elevated)	2,5 km/h	1.55 mph	2,5 km/h	1.55 mph
• High (Machine folded/stowed)	5,0 km/h	3.11 mph	5,0 km/h	3.11 mph
Maximum freewheel speed during towed operation	5,0 km/h	3.11 mph	5,0 km/h	3.11 mph
<b>Engine - Tier III</b>				
Engine type	Kubota V2403 - M - E3 - 35,5 kW			
Engine power	36,5 kW			
Power consumption	29,4 kW			
CO emission	1 g/kWh			
HC + NO emission	6.44 g/kWh			
Particles emission	0.43 g/kWh			
Av fuel consumption	4.5 l/h - 1.19 gal/h			
Fuel type	Diesel Fuel Only			
<b>Engine - Tier IV</b>				
Engine type	Kubota V2403 CR - 37 kW			
Engine power	37,4 kW			
CO emission	0,07 g/kWh			
HC + NO emission	2,73 g/kWh			
Particles emission	0,02 g/kWh			
Av fuel consumption	3,5 l/h - 0.93 gal/h			
Fuel type	Diesel Fuel Only			

# B - Familiarization

Machine	HA20RTJ		HA20RTJ O	
<b>Specifications - Performance</b>				
Operating temperature	- 15° C / + 35° C ( - 59° F / + 95° F)			
Storage temperature	- 30° C / + 45° C (-22° F / + 113° F)			
<b>Energy storage</b>				
Type of battery	12 V 100 Ah 800A			
Battery amperage	830 A			
Battery voltage	12 V			
Battery capacity	100 Ah			
Hydraulic tank capacity	140 L	37 gal US	140 L	37 gal US
Fuel tank capacity	80 L	21 gal US	80 L	21 gal US

1. The pressure values are given for standard machines without Option

# B - Familiarization

## CE and AS standards

Machine	HA20RTJ PRO	
Characteristics - Dimensions	SI	Imp.
Maximum working height	20,60 m	67 ft 7 in
Maximum platform height	18,60 m	61 ft 0 in
Maximum horizontal reach	12,10 m	39 ft 8 in
Maximum outreach above the ground	11,60 m	38 ft 1 in
Maximum platform height before driving speed restriction	6 m	19 ft 8 in
Maximum boom articulation point height	8,10 m	26 ft 7 in
Maximum load capacity	230 kg	500 lbs
Jib working range	140° (+60° / -80°)	
Basket rotation angle	180° (+ 90° / -90°)	
Boom rotation angle	75°	
Turntable rotation	360° Continuous	
Maximum number of occupants allowed	2	
Maximum wind speed allowed	60 km/h	37 mph
Gradeability	45%	
Sideslope	25%	
Maximum rated slope allowed - CE - AS	5°	
Manual force - CE - AS	400 N - 90 lbf	
Maximum load on wheel	4950 daN	11,128 lbs
Outside turning radius - 4WS	3,75 m	12 ft 4 in
Inside turning radius - 4WS	1,75 m	5 ft 9 in
Outside turning radius - 2WS	4,50 m	14 ft 9 in
Inside turning radius - 2WS	2,40 m	7 ft 10 in
Maximum ground pressure of wheel on paved ground <sup>1</sup>	12,9 daN/cm <sup>2</sup>	2,70 lb/ft <sup>2</sup>
Total weight	9600 kg	21,168 lbs
Drive speed (4WS) :		
• Low (Machine elevated)	1,2 km/h	0.75 mph
• Medium (Machine elevated)	2,5 km/h	1.55 mph
• High (Machine folded/stowed)	5,0 km/h	3.11 mph
Drive speed (2WS) :		
• Low (Machine elevated)	1,2 km/h	0.75 mph
• Medium (Machine elevated)	2,5 km/h	1.55 mph
• High (Machine folded/stowed)	5,0 km/h	3.11 mph
Maximum freewheel speed during towed operation	5,0 km/h	3.11 mph
<b>Engine - Tier III</b>		
Engine type	Kubota V2403 - M - E3 - 35,5 kW	
Engine power	36,5 kW	
Power consumption	29,4 kW	
CO emission	1 g/kWh	
HC + NO emission	6.44 g/kWh	
Particles emission	0.43 g/kWh	
Av fuel consumption	4.5 l/h - 1.19 gal/h	
Fuel type	Diesel Fuel Only	
<b>Engine - Tier IV</b>		
Engine type	Kubota V2403 CR - 37 kW	
Engine power	37,4 kW	
CO emission	0,07 g/kWh	
HC + NO emission	2,73 g/kWh	
Particles emission	0,02 g/kWh	
Av fuel consumption	3,5 l/h - 0.93 gal/h	
Fuel type	Diesel Fuel Only	
<b>Specifications - Performance</b>		
Operating temperature	- 15° C / + 35° C ( - 59° F / + 95° F)	

# B - Familiarization

Machine	HA20RTJ PRO	
Storage temperature	- 30° C / + 45° C (-22° F / + 113° F)	
<b>Energy storage</b>		
Type of battery	12 V 100 Ah 800A	
Battery amperage	830 A	
Battery voltage	12 V	
Battery capacity	100 Ah	
Hydraulic tank capacity	140 L	37 gal US
Fuel tank capacity	80 L	21 gal US

1. The pressure values are given for standard machines without Option

# B - Familiarization

## ANSI and CSA standards

Machine	HA61RTJ O		HA61RTJ PRO	
	SI	Imp.	SI	Imp.
<b>Characteristics - Dimensions</b>				
Maximum working height	20,60 m	67 ft 7 in	20,60 m	67 ft 7 in
Maximum platform height	18,60 m	61 ft 0 in	18,60 m	61 ft 0 in
Maximum horizontal reach	12,10 m	39 ft 8 in	12,10 m	39 ft 8 in
Maximum outreach above the ground	11,60 m	38 ft 1 in	11,60 m	38 ft 1 in
Maximum platform height before driving speed restriction	6 m	19 ft 8 in	6 m	19 ft 8 in
Maximum boom articulation point height	8,10 m	26 ft 7 in	8,40 m	27 ft 7 in
Maximum load capacity	230 kg	500 lbs	230 kg	500 lbs
Jib working range	140° (+60° / -80°)			
Basket rotation angle	180° (+ 90° / -90°)			
Boom rotation angle	75°			
Turntable rotation	355° non continuous		360° Continuous	
Maximum number of occupants allowed	2			
Maximum wind speed allowed	45 km/h	28 mph	45 km/h	28 mph
Gradeability	45%			
Sideslope	25%			
Maximum rated slope allowed - ANSI - CSA	0°			
Manual force - ANSI - CSA	667 N - 150 lbf			
Maximum load on wheel	4960 daN	11,150 lbs	4950 daN	11,128 lbs
Outside turning radius - 4WS	NA		3,75 m	12 ft 4 in
Inside turning radius - 4WS	NA		1,75 m	5 ft 9 in
Outside turning radius - 2WS	4,50 m	14 ft 9 in	4,50 m	14 ft 9 in
Inside turning radius - 2WS	2,40 m	7 ft 10 in	2,40 m	7 ft 10 in
Maximum ground pressure of wheel on paved ground <sup>1</sup>	15,3 daN/cm <sup>2</sup>	5940 daN	12,9 daN/cm <sup>2</sup>	2,70 lb/ft <sup>2</sup>
Total weight	9500 kg	20,948 lbs	9600 kg	21,168 lbs
<b>Drive speed (4WS) :</b>				
• Low (Machine elevated)			1,2 km/h	0.75 mph
• Medium (Machine elevated)			2,5 km/h	1.55 mph
• High (Machine folded/stowed)	NA	NA	5,0 km/h	3.11 mph
<b>Drive speed (2WS) :</b>				
• Low (Machine elevated)	1,2 km/h	0.75 mph	1,2 km/h	0.75 mph
• Medium (Machine elevated)	2,5 km/h	1.55 mph	2,5 km/h	1.55 mph
• High (Machine folded/stowed)	5,0 km/h	3.11 mph	5,0 km/h	3.11 mph
Maximum freewheel speed during towed operation	5,0 km/h	3.11 mph	5,0 km/h	3.11 mph
<b>Engine - Tier III</b>				
Engine type	Kubota V2403 - M - E3 - 35,5 kW			
Engine power	36,5 kW			
Power consumption	29,4 kW			
CO emission	1 g/kWh			
HC + NO emission	6.44 g/kWh			
Particles emission	0.43 g/kWh			
Av fuel consumption	4.5 l/h			
Fuel type	Diesel Fuel Only			
<b>Engine - Tier IV</b>				
Engine type	Kubota V2403 CR - 37 kW			
Engine power	37,4 kW			
CO emission	0,07 g/kWh			
HC + NO emission	2,73 g/kWh			
Particles emission	0,02 g/kWh			
Av fuel consumption	3,5 l/h - 0.93 gal/h			
Fuel type	Diesel Fuel Only			

# B - Familiarization

Machine	HA61RTJ O		HA61RTJ PRO	
<b>Engine - Dual Fuel (Petrol / Gas)</b>				
Engine	Kubota WG 1605 - GL - E03- 38 kW - 51 hp			
CO emission	20,6 g/kWh			
HC + NO emission	0,8 g/kWh			
Fuel type	Petrol/Gas			
<b>Specifications - Performance</b>				
Operating temperature	- 15° C / + 35° C ( - 59° F / + 95° F)			
Storage temperature	- 30° C / + 45° C (-22° F / + 113° F)			
<b>Energy storage</b>				
Type of battery	12 V 100 Ah 800A			
Battery amperage	830 A			
Battery voltage	12 V			
Battery capacity	100 Ah			
Hydraulic tank capacity	140 L	37 gal US	140 L	37 gal US
Fuel tank capacity	80 L	21 gal US	80 L	21 gal US

1. The pressure values are given for standard machines without Option

# B - Familiarization

## 4.2 - WORKING AREA / RANGE OF MOTION

### HA20RTJ - HA20RTJ O - HA20RTJ PRO - HA61RTJ O - HA61RTJ PRO

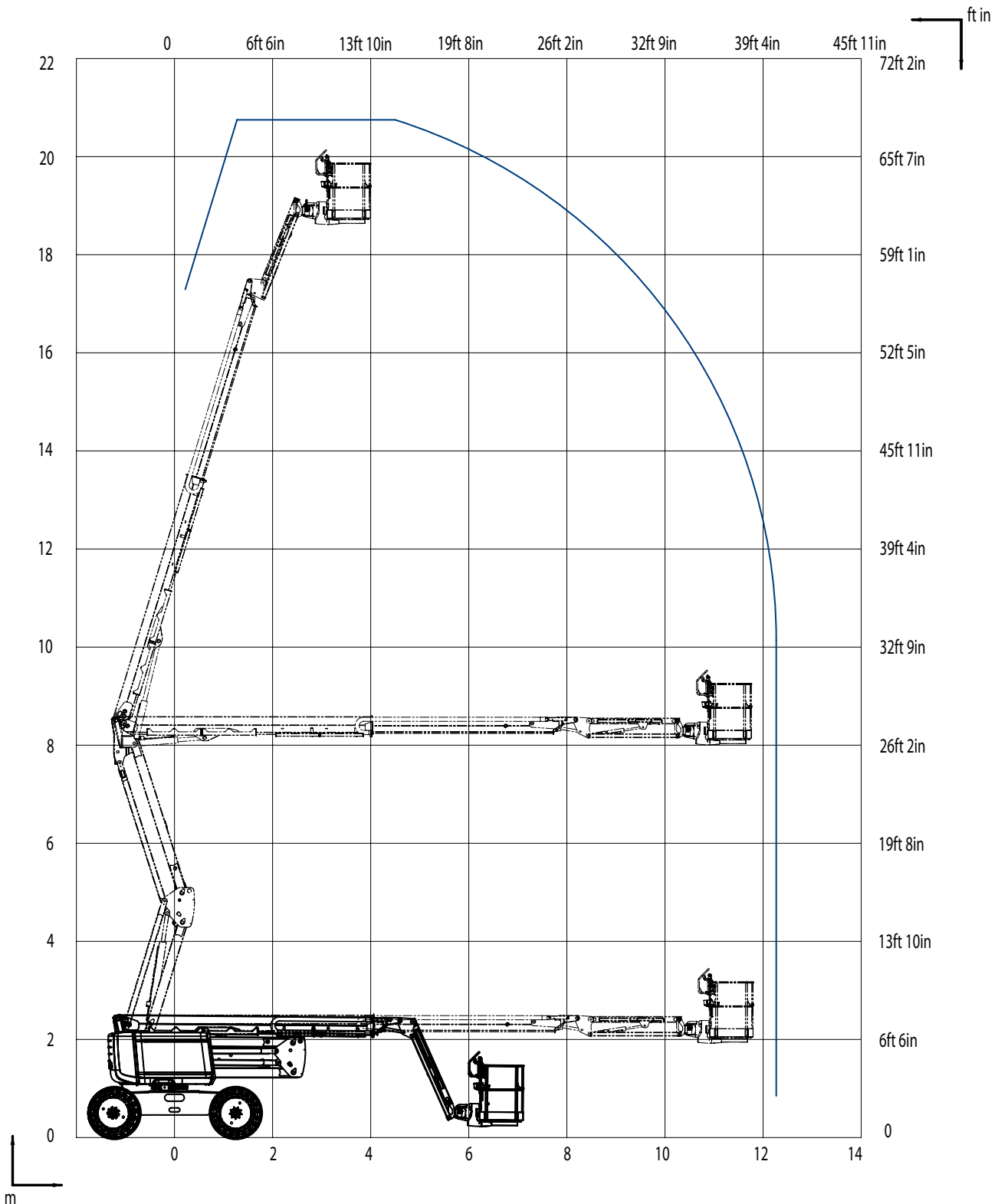

# B - Familiarization

## 5 - Decals and markings locations

CE standard

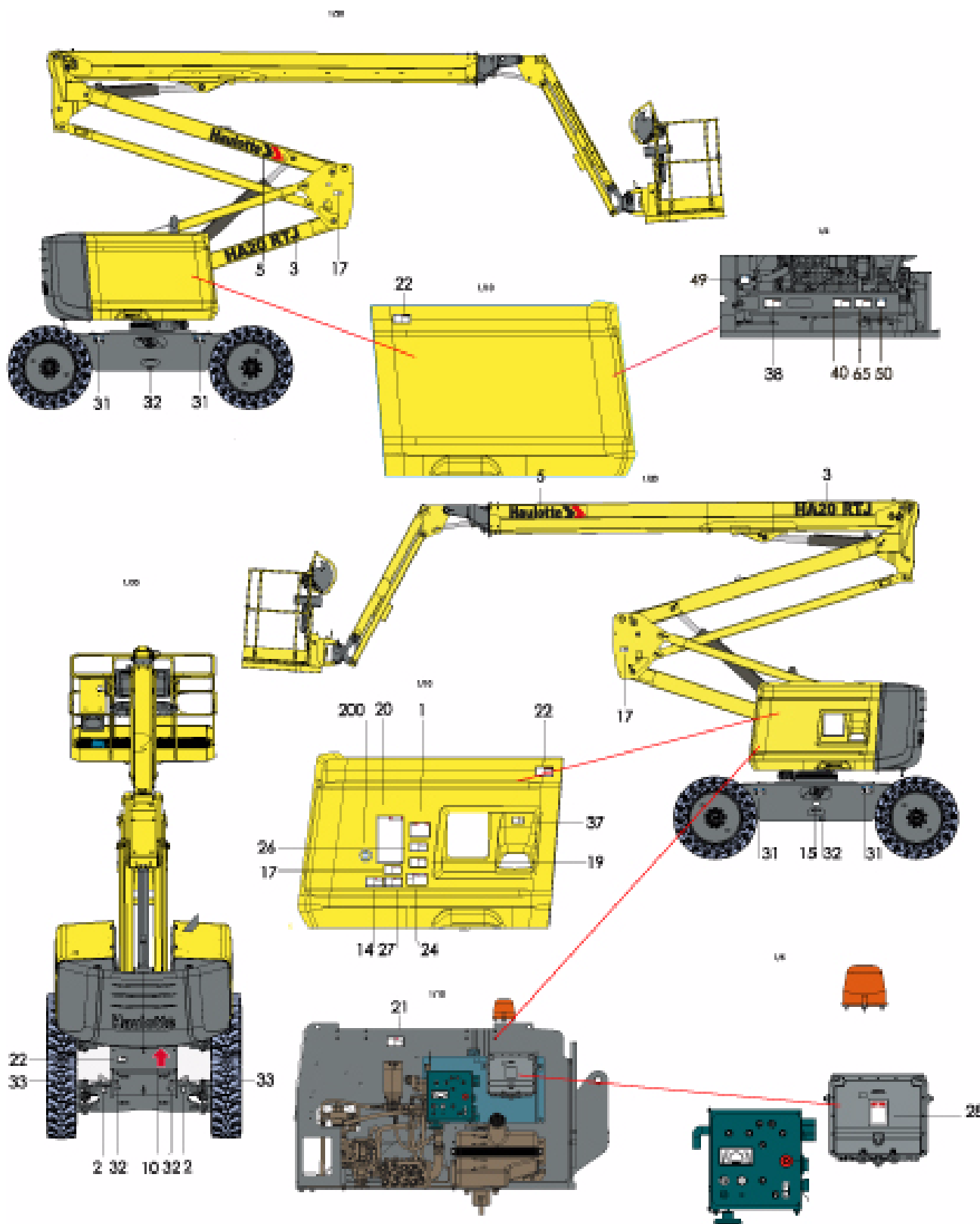

# B - Familiarization

CE standard

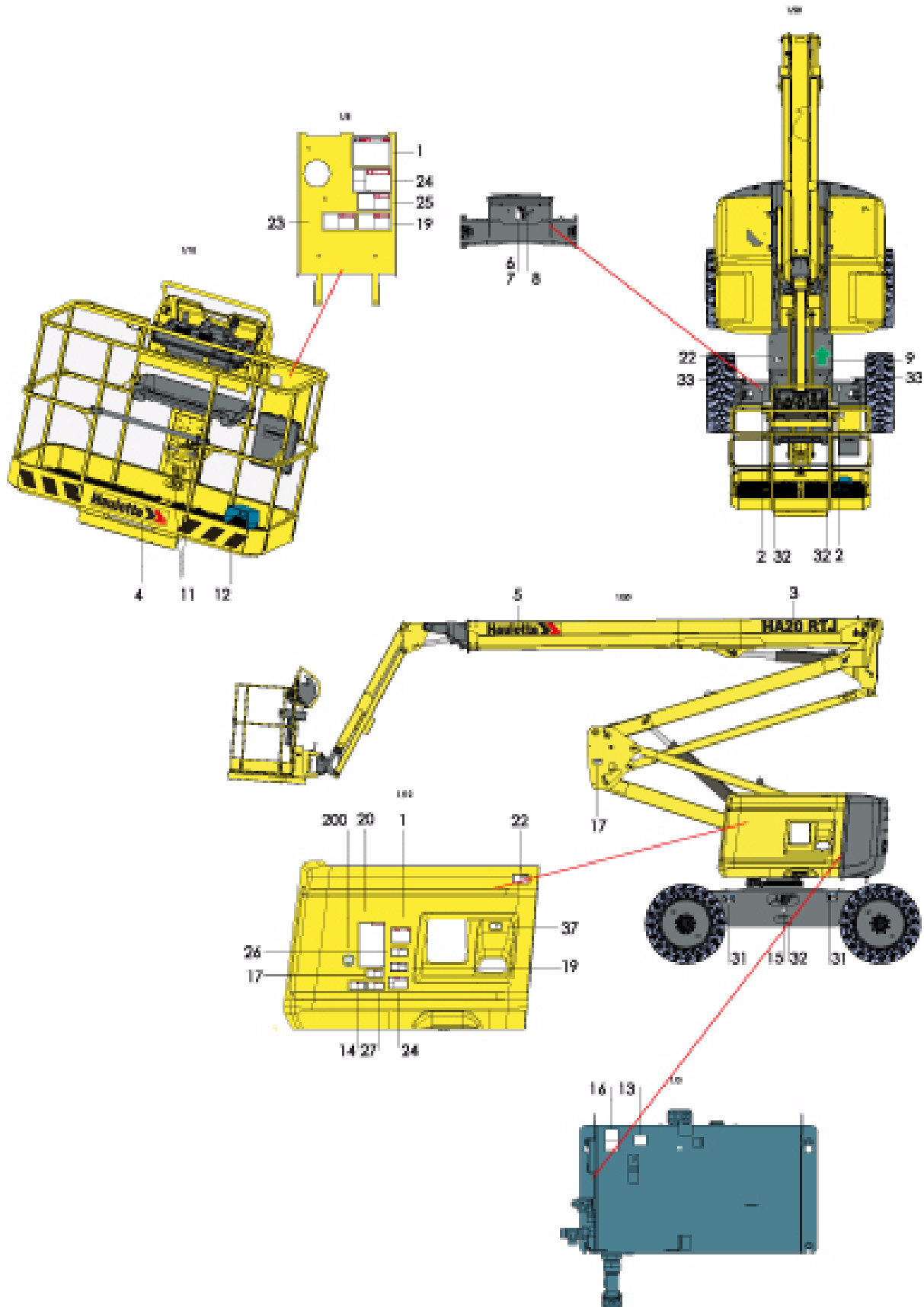

A

B

C

D

E

F

G

H

I

# B - Familiarization

## CE standard

Marking	Color	Description	Quantity	HA20RTJ	HA20RTJO	HA20RTJ PRO
1	Red	Height of the floor and load	2	4000470990		
2	Blue	Maximum Pressure per Tire - Floor Loading	4	4000359590	4000472650	4000359590
3	Other	Commercial name	1	4000359400	4000359420	4000359440
4	Other	500 x 100 Decal HAULOTTE®Bright machine	1	307P217080		
		500 x 100 Decal HAULOTTE®Dark machine		307P224740		
		500 x 100 Decal HAULOTTE®Red machine		307P220360		
5	Other	820 x 130 Decal HAULOTTE®Bright machine	2	307P217230		
		820 x 130 Decal HAULOTTE®Dark machine		3078224930		
		820 x 130 Decal HAULOTTE®Red machine		3078224920		
6	Other	Identification plates	1	307P218070		
7	Other	Rivet TAPD 48 BS	4	2421803570		
8	Other	Noise emission level104 Db	1	3078148700		
9	Other	Control of movements - GREEN directional arrow	1	3078143930		
10	Other	Control of movements - RED directional arrow	1	3078143940		
11	Other	Lanyard attachment points - Harness attachment compulsory	9	307P216290		
12	Other	Material risk - Yellow and black adhesive tape	1	2421808660		
13	Other	Hydraulic oil	1	307P221080		
14	Red	Risk of crushing - Spindle	1	4000027080		
15	Other	Crown greasing	1	4000025160		
16	Other	Upper and lower oil level	1	307P221060		
17	Red	Risk of crushing - Do not park	3	4000024800		
18	Orange	Hand crushing hazard - Risk of crushed hands	2	4000024890		
19	Other	Read the operation manual	2	4000025140		
22	Orange	Risk of crushing - Do not place foot	4	4000027090		
23	Red	Risk of crushing - Driving direction	1	4000024690		
24	Red	Danger of electrocution	2	4000025070		
25	Red	Risk of crushing - Closing drop rail	1	4000025080		

# B - Familiarization

26	Red	Danger of electrocution - Platform - Ground for welding	1	4000027100
27	Other	Tilt verification	1	4000027110
28	Other	Do not interchange	1	3078145180
32	Blue	Towing anchorage point	4	4000027310
33	Blue	Lifting anchorage point	4	4000027330
34	Red	Electrocution Hazard - Water projection	1	4000025130
35	Red	Operation instructions - Horizontal	1	In german : 307P222730 In english : 307P222740 In croatian : 4000360810 In danish : 307P222760 In spanish : 307P222770 In estonian : 4000360870 In finish : 307P222780 In french : 3078149030 In hungarian : 4000360890 In italian : 307P222800 In japanese : 4000359830 In latvian : 4000359840 In lithuanian : 4000359850 In dutch : 307P222790 In norwegian : 4000359900 In polish : 4000359860 In portuguese : 307P222810 In romanian : 4000359870 In slovakian : 4000359880 In slovenian : 4000359890 In swedish : 307P222820
37	Red	Risks of explosion	1	4000027370
38	Orange	Hand crushing hazard - Heat burns	1	4000027450
40	Orange	Hand crushing hazard - Snapping up	1	4000027430
49	Blue	Battery +	1	4000071960
50	Blue	Battery -	1	4000071970
68	Other	Transport height	1	4000417480
200	Other	Made in Europe	1	4000137690

# B - Familiarization

## AS standard

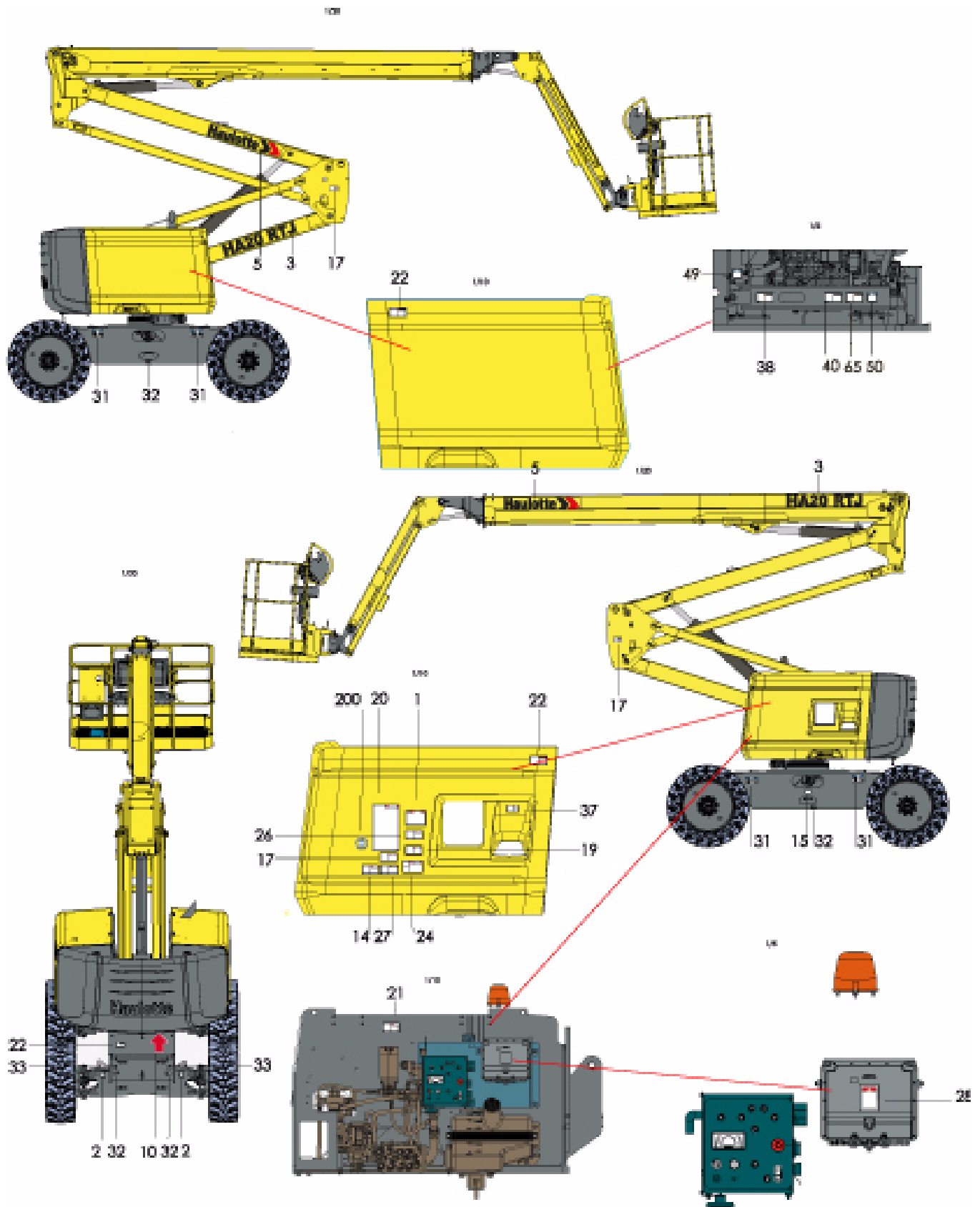

# B - Familiarization

AS standard

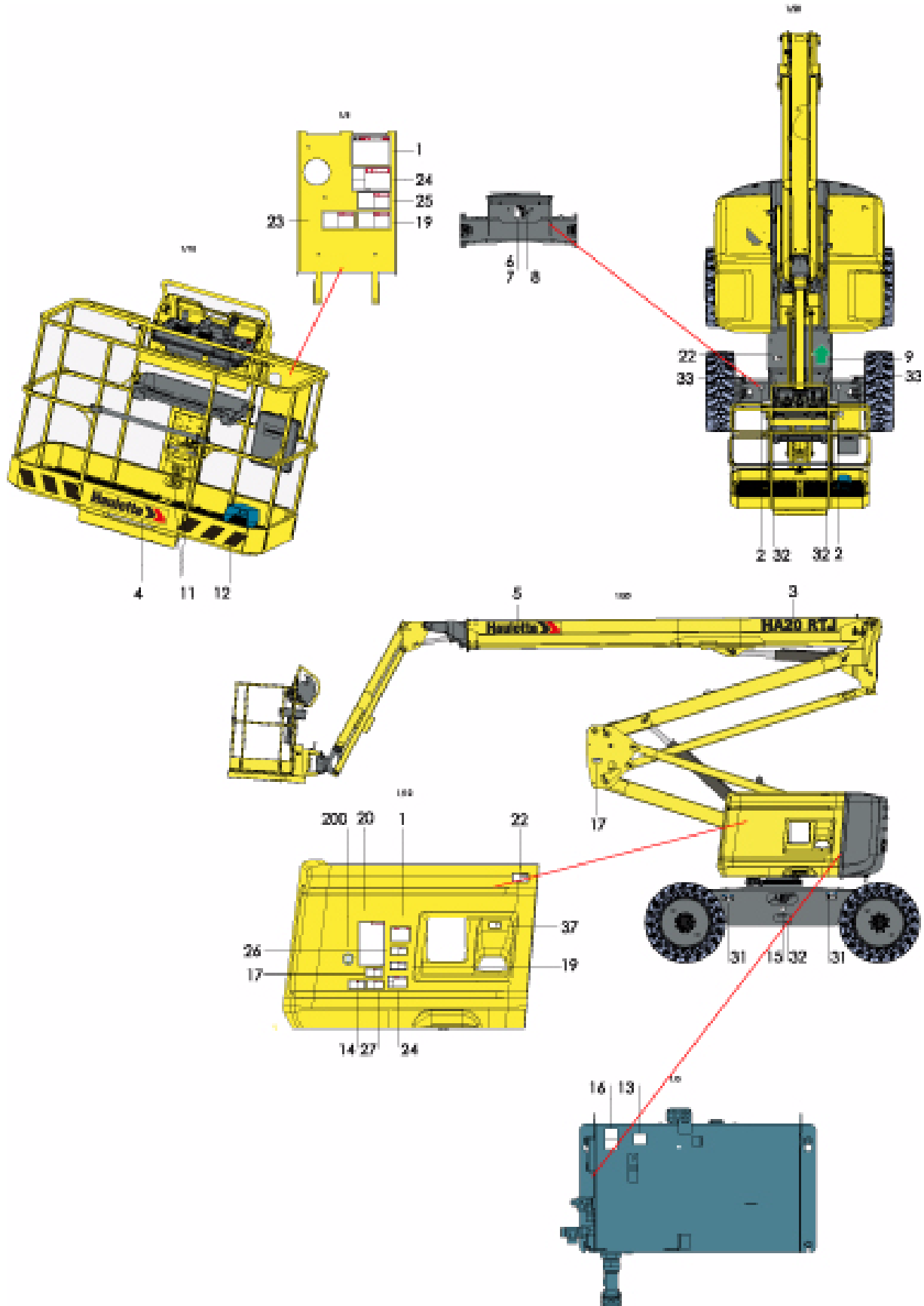

A

B

C

D

E

F

G

H

I

# B - Familiarization

## AS standard

Marking	Color	Description	Quantity	HA20RTJ	HA20RTJO	HA20RTJ PRO
1	Red	Height of the floor and load	2	4000470990		
2	Blue	Maximum Pressure per Tire - Floor Loading	4	4000359590	4000472650	4000359590
3	Other	Commercial name	1	4000359400	4000359420	4000359440
4	Other	500 x 100 Decal HAULOTTE®Bright machine	1	307P217080		
		500 x 100 Decal HAULOTTE®Dark machine		307P224740		
		500 x 100 Decal HAULOTTE®Red machine		307P220360		
5	Other	820 x 130 Decal HAULOTTE®Bright machine	2	307P217230		
		820 x 130 Decal HAULOTTE®Dark machine		3078224930		
		820 x 130 Decal HAULOTTE®Red machine		3078224920		
6	Other	Identification plates	1	307P218070		
7	Other	Rivet TAPD 48 BS	4	2421803570		
9	Other	Control of movements - GREEN directional arrow	3	3078143930		
10	Other	Control of movements - RED directional arrow	3	3078143940		
11	Other	Lanyard attachment points - Harness attachment compulsory	9	307P216290		
12	Other	Material risk - Yellow and black adhesive tape	1	2421808660		
13	Other	Hydraulic oil	1	307P221080		
14	Red	Risk of crushing - Spindle	1	4000027080		
15	Other	Crown greasing	1	4000025160		
16	Other	Upper and lower oil level	1	307P221060		
17	Red	Risk of crushing - Do not park	3	4000024800		
18	Orange	Hand crushing hazard - Risk of crushed hands	2	4000024890		
19	Other	Read the operation manual	2	4000025140		
22	Orange	Risk of crushing - Do not place foot	4	4000027090		
23	Red	Risk of crushing - Driving direction	1	4000024690		
24	Red	Danger of electrocution	2	4000227500		

# B - Familiarization

25	Red	Risk of crushing - Closing drop rail	1	4000025080
26	Red	Danger of electrocution - Platform - Ground for welding	2	4000027100
27	Other	Tilt verification	1	4000027110
28	Other	Do not interchange	1	3078145180
32	Blue	Towing anchorage point	6	4000027310
33	Blue	Lifting anchorage point	4	4000027330
35	Red	Operation instructions - Horizontal	1	307P227220
36	Red	Risk of crushing - Emergency lowering	1	4000027460
37	Red	Risks of explosion	1	4000027370
38	Orange	Hand crushing hazard - Heat burns	1	4000027450
40	Orange	Hand crushing hazard - Snapping up	1	4000027430
49	Blue	Battery +	1	4000071960
50	Blue	Battery -	1	4000071970
68	Other	Transport height	1	4000417480
201	Other	Wearing of a safety harness is essential	2	3078144520

# B - Familiarization

For Russia and the Ukraine only

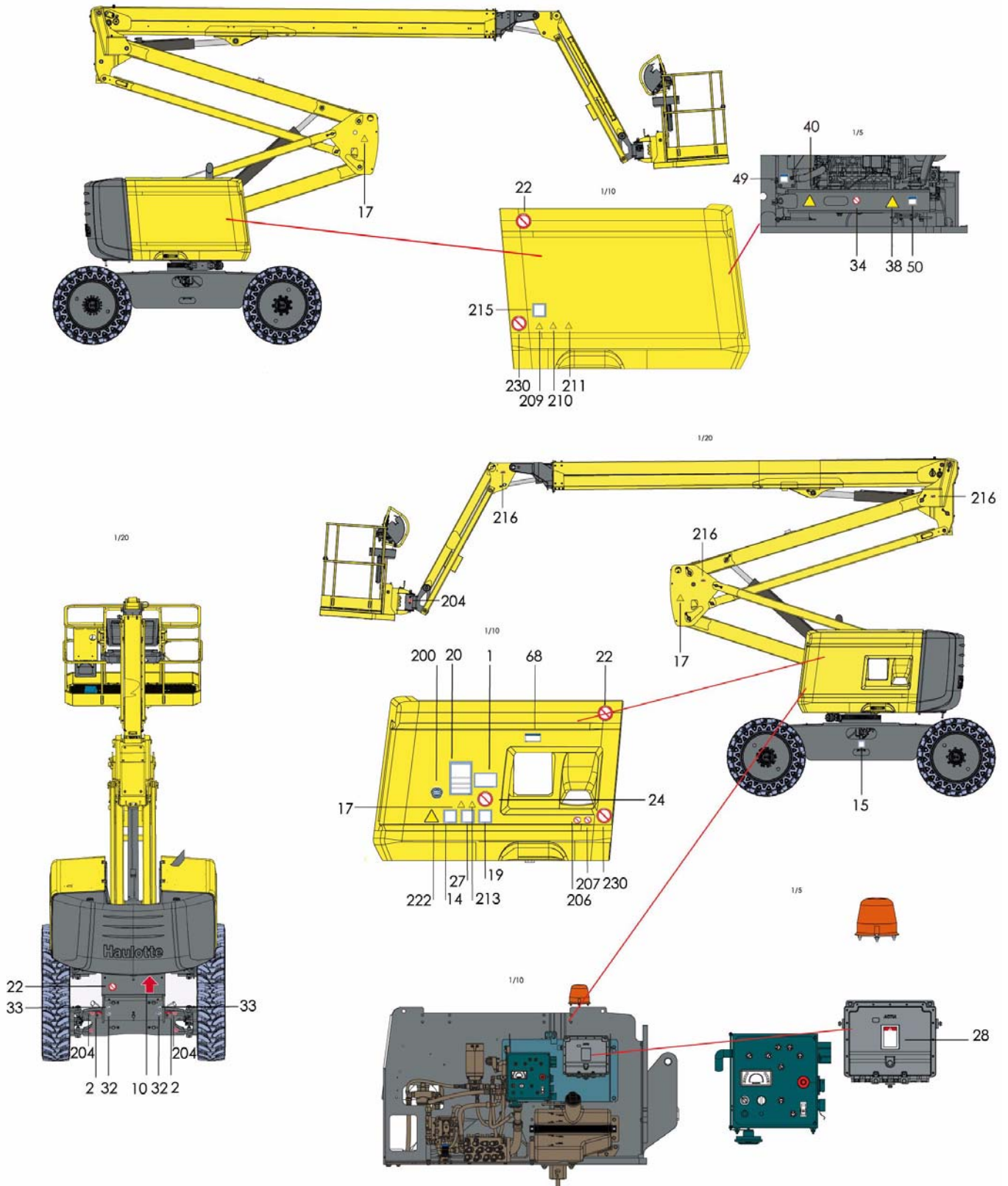

# B - Familiarization

For Russia and the Ukraine only

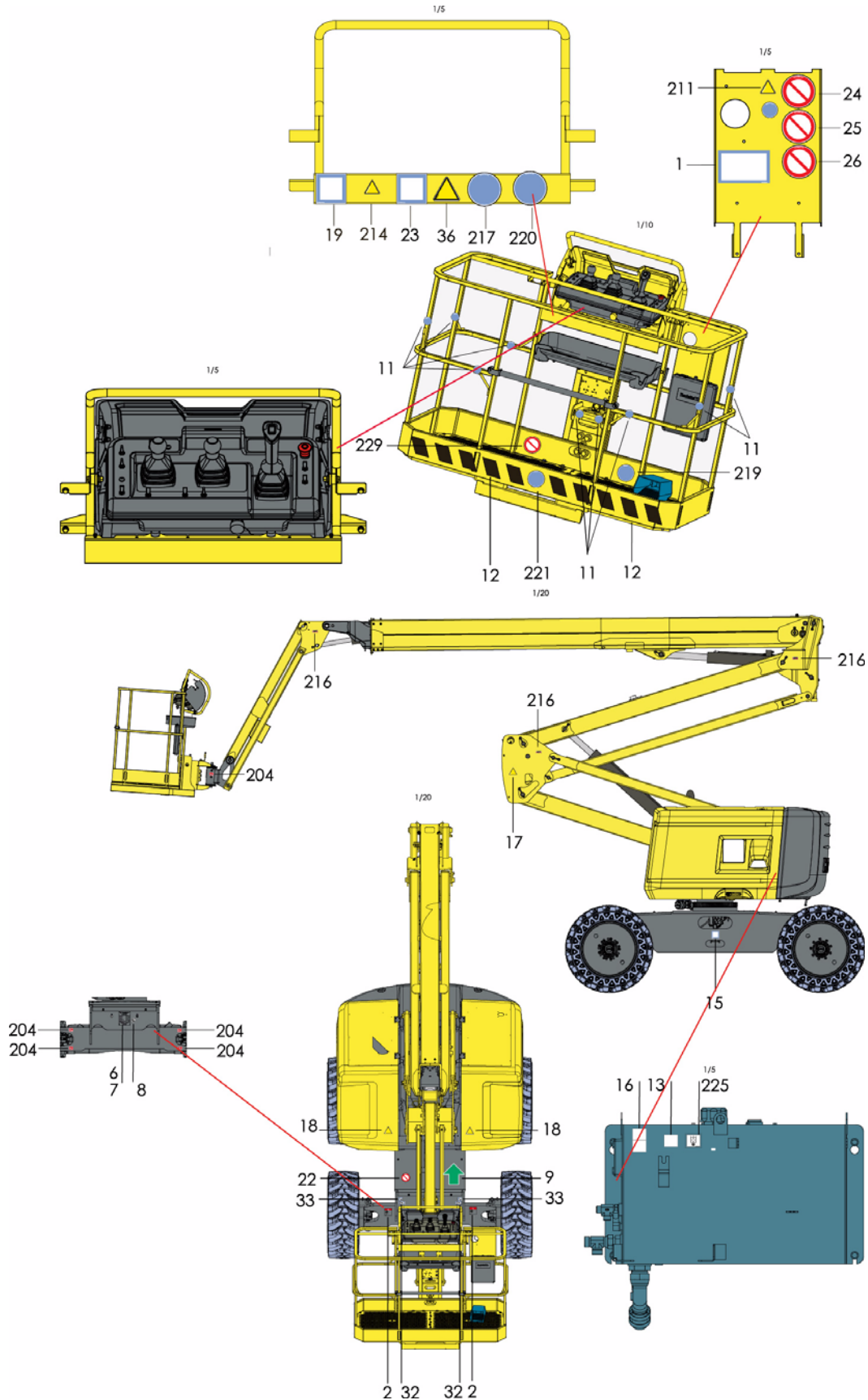

A

B

C

D

E

F

G

H

I

# B - Familiarization

## For Russia and the Ukraine only

Marking	Color	Description	Quantity	HA20RTJ	HA20RTJO	HA20RTJ PRO
1	Red	Height of the floor and load	2	4000423800		
2	Blue	Maximum Pressure per Tire - Floor Loading	4	4000359590	4000472650	4000359590
3	Other	Commercial name	1	4000359400	4000359420	4000359440
6	Other	Identification plates	1	For Russia : 4000278870 For Ukraine : 307P227830		
7	Other	Rivet TAPD 48 BS	4	2421803570		
8	Other	Noise emission level104 Db	1	3078148700		
9	Other	Control of movements - GREEN directional arrow	3	3078143930		
10	Other	Control of movements - RED directional arrow	3	3078143940		
11	Other	Lanyard attachment points - Harness attachment compulsory	9	307P226710		
12	Other	Material risk - Yellow and black adhesive tape	1	2421808660		
13	Other	Hydraulic oil	1	307P221080		
14	Red	Risk of crushing - Spindle	1	307P227810		
15	Other	Crown greasing	1	307P227020		
16	Other	Upper and lower oil level	1	307P221060		
17	Red	Risk of crushing - Do not park	3	307P227670		
18	Orange	Hand crushing hazard - Risk of crushed hands	2	307P227660		
19	Other	Read the operation manual	2	For Russia : 307P227190 For Ukraine : 307P227840		
20	Red	Operation instructions - Vertical	1	For Russia : 307P225160 For Ukraine : 307P227850		
22	Orange	Risk of crushing - Do not place foot	2	307P227010		
23	Red	Risk of crushing - Driving direction	1	307P227040		
24	Red	Danger of electrocution	2	307P226960		
25	Red	Risk of crushing - Closing drop rail	1	307P226950		
26	Red	Danger of electrocution - Platform - Ground for welding	2	307P226970		
27	Other	Tilt verification	1	For Russia : 307P227060 For Ukraine : 307P227870		
28	Other	Do not interchange	1	3078145180		

# B - Familiarization

32	Blue	Towing anchorage point	4	4000135970	
33	Blue	Lifting anchorage point	4	4000135960	
34	Red	Electrocution Hazard - Water projection	1	307P226760	
36	Red	Risk of crushing - Emergency lowering	1	4000014290	
38	Orange	Hand crushing hazard - Heat burns	1	4000200810	
40	Orange	Hand crushing hazard - Snapping up	1	307P226940	
49	Blue	Battery +	1	4000071960	
50	Blue	Battery -	1	4000071970	
68	Other	Transport height	1	4000417480	
204	Other	Lubrication point	9	307P219370	
205	Other	Caution disconnect	1	307P226690	
206	Other	Flames prohibited	1	307P226750	
207	Other	Smoking forbidden	1	307P226760	
209	Other	Battery danger	1	307P226790	
210	Other	Fire Hazard	1	307P226800	
211	Other	Electrical danger	2	307P226810	
213	Other	Corrosion hazard	1	307P226830	
214	Other	Danger unstable side H41	1	307P226930	
215	Other	Battery maintenance	1	For Russia : 307P227180 For Ukraine : 307P227860	
216	Other	Tamper-proof	5/7	307P227450 X 5	307P227450 X 7
217	Other	Caution glasses	1	307P227460	
219	Other	Caution helmet compulsory	1	307P227470	
220	Other	hand protection compulsory	1	307P227490	
221	Other	Obligatory routing	1	307P227510	
222	Other	Danger unstable side H87	1	307P227680	
223	Other	Electric socket 12 V - 47	1	307P227700	
225	Other	Cold weather oil	1	307P223700	
226	Other	Tilt verification - Large size	1	4000011690	
229	Other	Do not travel down slopes in high speed	1	4000275680	
230	Other	No admittance	1	307P227560	

# B - Familiarization

## ANSI and CSA standards

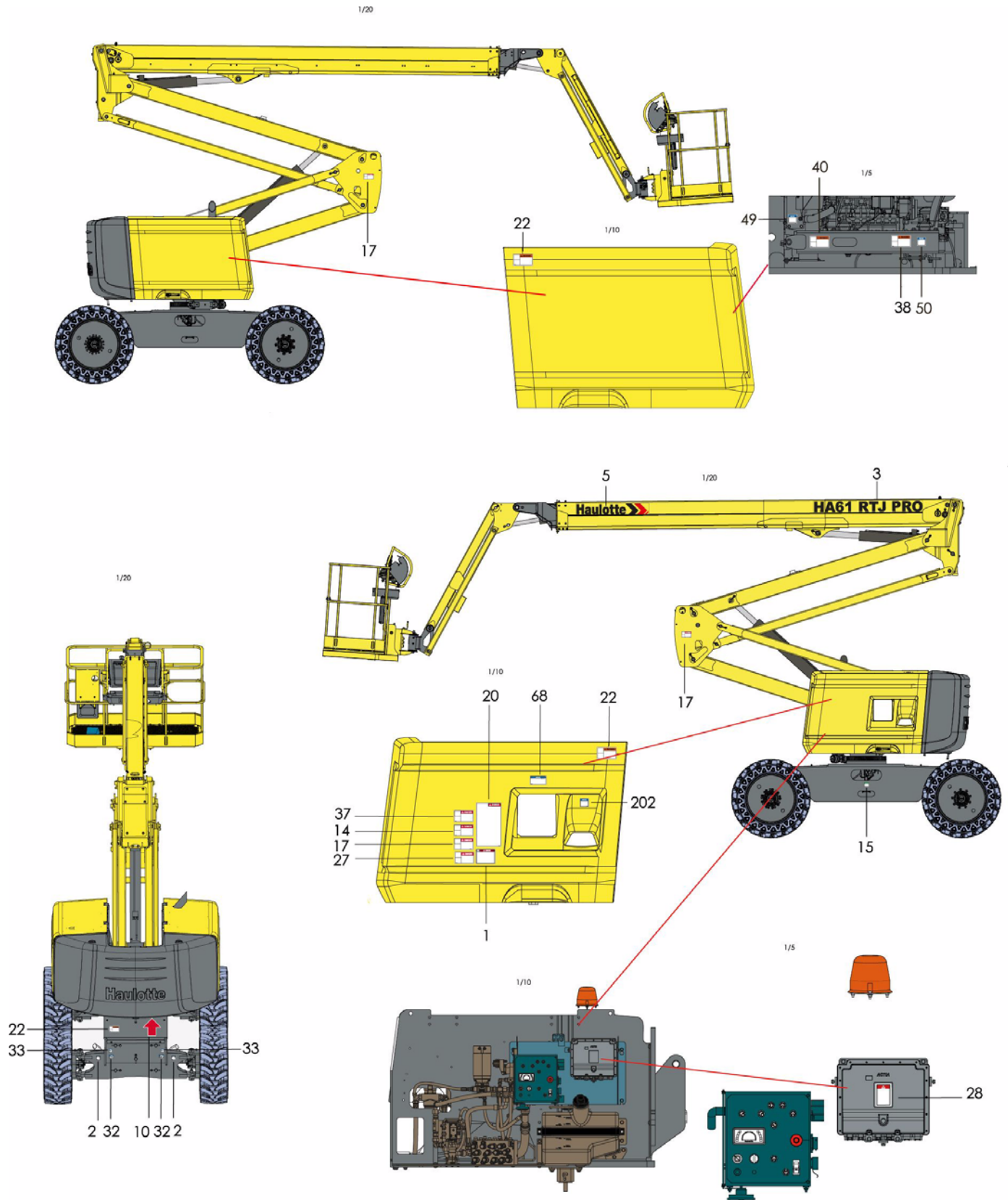

# B - Familiarization

## ANSI and CSA standards

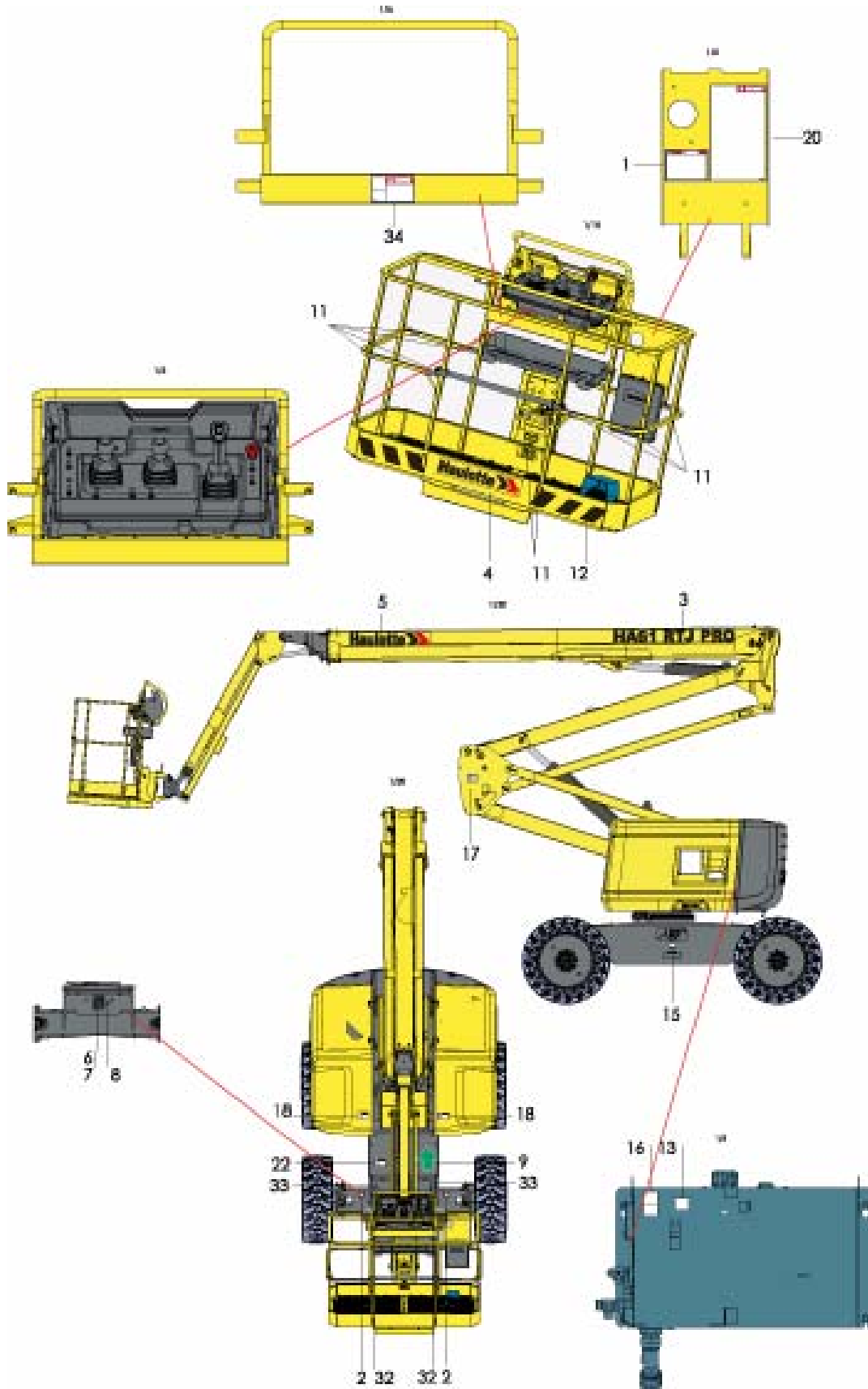

A

B

C

D

E

F

G

H

I

# B - Familiarization

## ANSI and CSA standards

Marking	Color	Description	Quantity	HA61RTJO	HA61RTJ PRO
1	Red	Height of the floor and load	3	In english : 4000242370 In french : 4000424370 In spanish : 4000424380	In english : 4000242370 In french : 4000424370 In spanish : 4000424380
2	Blue	Maximum Pressure per Tire - Floor Loading	4	4000472650	4000359590
3	Other	Commercial name	1	4000359460	4000359460
4	Other	500 x 100 Decal HAULOTTE®Bright machine	1	307P217080	
		500 x 100 Decal HAULOTTE®Dark machine		307P224740	
		500 x 100 Decal HAULOTTE®Red machine		307P220360	
5	Other	1040 x 160 Decal HAULOTTE®Bright machine	1	307P217230	
		1040 x 160 Decal HAULOTTE®Dark machine		3078224930	
		1040 x 160 Decal HAULOTTE®Red machine		3078224920	
6	Other	Identification plates	1	307P218170	
7	Other	Rivet TAPD 48 BS	4	2421803570	
9	Other	Control of movements - GREEN directional arrow	3	3078143930	
10	Other	Control of movements - RED directional arrow	3	3078143940	
11	Other	Lanyard attachment points - Harness attachment compulsory	9	307P216290	
12	Other	Material risk - Yellow and black adhesive tape	1	2421808660	
13	Other	Hydraulic oil	1	307P221080	
14	Red	Risk of crushing - Spindle	1	In english : 4000024830 In french : 4000068080 In spanish : 4000086510	
15	Other	Crown greasing	1	4000025160	
16	Other	Upper and lower oil level	1	307P221060	
17	Red	Risk of crushing - Do not park	3	In english : 4000024640 In french : 4000067680 In spanish : 4000086460	
18	Orange	Hand crushing hazard - Risk of crushed hands	2	In english : 4000024770 In french : 4000067110 In spanish : 4000086490	
22	Orange	Risk of crushing - Do not place foot	2	In english : 4000024840 In french : 4000068180 In spanish : 4000086610	

# B - Familiarization

27	Other	Tilt verification	1	In english : 4000024860 In french : 4000068090 In spanish : 4000086520
28	Other	Do not interchange	1	3078145180
32	Blue	Towing anchorage point	4	4000027310
33	Blue	Lifting anchorage point	4	4000027330
27	Other	Tilt verification	1	In english : 4000024860 In french : 4000068090 In spanish : 4000086520
34	Red	Electrocution Hazard - Water projection	1	In english : 4000024810 In french : 4000068160 In spanish : 4000086590
37	Red	Explosion hazard	1	In english : 4000025010 In french : 4000068130 In spanish : 4000086560
38	Orange	Hand crushing hazard - Heat burns	1	In english : 4000025040 In french : 4000068110 In spanish : 4000086540
39	Blue	Engine oil - CJ-4	1	4000019700
40	Orange	Hand crushing hazard - Snapping up	1	In english : 4000025020 In french : 4000068100 In spanish : 4000086530
49	Blue	Battery +	1	4000071960
50	Blue	Battery -	1	4000071970
54	Blue	Option - Biodegradable oil	1	3078148890
55	Blue	Option - Gasoline fuel only	1	4000325700
56	Blue	Option - LPG commercial horizontal	1	4000325710
57	Blue	Option - LPG commercial vertical	1	4000325720
68	Other	Transport height	1	4000417480
202	Other	Diesel Fuel Only	2	4000201430



# C - Pre-operation inspection

## 1 - Recommendations

The owner, the site manager, the supervisor and the operator are all responsible to ensure the machine is fit for the work it is to perform; i.e. that the machine is suitable to carry out the work in complete safety and in compliance with this Operator's Manual. All managers who are responsible for persons operating the machine must be familiar with the local regulations currently applicable in the country of use and ensure that they are adhered to.

Before using the machine, read the previous chapters in this manual. Ensure that you have understood the following points :

- Safety precautions.
- Operator's responsibilities.
- Conditions and the operating principles of the machine.

## 2 - Working area assessment

To ensure safety during operation, the following should be considered :

- Segregate other site traffic (delivery vehicles, dumpers, etc) from the work area.
- Check the work area for localised features, e.g. manholes, service ducts, potholes, etc.
- Check ground covers (temporary and permanent) are strong enough to withstand the applied pressure
- Check ground covers are secured and monitor them. Take similar action for permanent covers.
- Establish the load bearing capacity (distributed load and point loading, e.g. outriggers) when working inside a building or on a structure.
- Provide supervision to ensure safe systems of work are appropriate and being used.
- Check for overhead crushing and contact hazards.
- Check weather conditions have not altered ground conditions (e.g. heavy or prolonged rain).
- Establish limits for safe operation (e.g. maximum wind speed). Remember conditions can change internally (e.g. if roller doors are opened).
- Comply with permit to work systems where sites have them (e.g. chemical plants).
- Provide a rescue plan for all risks, including falls and crush hazards. Ensure personnel understand and are appropriately trained in the rescuing procedures. Site based personnel trained in operation of functions and in the emergency lowering systems from the ground control box should be present.
- Assess other alternative work methods or equipment before operating near a steep slope. If the machine must be placed near an edge or steep slope, ensure barriers are available to support the weight of the machine. Take into consideration the machine's stopping distance. If this is not possible, evaluate and establish the placement of machine and sequence of operations so that the aerial work platform can operate in a safe manner (e.g. machine is in line with the edge rather than towards the edge).

Extra care must be taken if aerial work platforms are used to manoeuvre up through several levels of steelwork. There is a risk of the operator being trapped should the basket strike the steelwork.

This risk increases with the number of steelwork levels and if material is piled up on lower level reducing the spacing between levels.

# C - Pre-operation inspection

## 3 - Inspection and Functional test

### 3.1 - DAILY INSPECTION

Each day before the beginning of a new work session and with each change of operator, the machine must be subjected to a visual inspection and a complete functional test.



- Never use a defective or a malfunctioning aerial work platform.
- If any item on the check list is marked "No" during the inspection; machine must be tagged and placed out of service.
- Do not operate the machine until all identified items are corrected and it has been declared safe for operation.

In case of loose fasteners, refer to torque table value in maintenance book.

In case of leaks, replace the damaged part before use.

In case of structural part deformation, cracks, broken weld, paint chips, replace the part before use.

#### Sample of broken welds

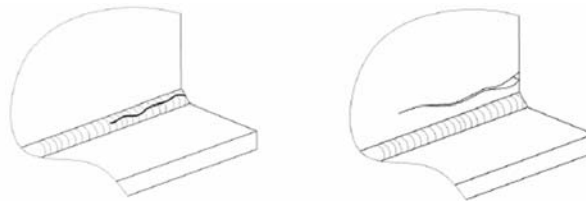

Inspection Forms are provided to assist your inspection process.

We recommend these forms to be completed daily and stored to assist with your maintenance schedule.

Each action is depicted in the daily inspection sheet using the following symbols.

	Visual inspection without disassembly		Lubrication-Grease		Functional adjustments
	Drain		Test and validate		Tighten
	Check levels		Systematic replacement		
	Visual inspection with small disassembly or movement needed to reach the part. Replacement is necessary.		Proof tests : Need HAULOTTE Services® authorization. For countries where machines are not subject to controlled periodic maintenance.		

# C - Pre-operation inspection

A  
B  
C  
D  
E  
F  
G  
H  
I

		Daily inspection				
	Visual inspection without disassembly		Check level			
			To check by test			
			Yes	No	Corrected	Not applicable
<b>Manuals and displays. Clean or replace if necessary.</b>						
	Presence, cleanliness and legibility of the manufacturer's plate					
	Presence, cleanliness and legibility of operator's and maintenance manuals					
	Presence and cleanliness of load chart of the machine					
<b>Control box (Ground and Platform)</b>						
	Presence and cleanliness of the control box					
	No visible damage					
	All decals at the control boxes are clean and legible					
	Operation of start / stop device					
	Operation of E-stop button device					
	Operation of enable switch					
	Operation of horn from platform control box					
	Operation of movement from platform control box					
	Test warning alarm lights and buzzer					
	Overriding indicators turn off after 1 sec					
	Overriding switch at ground control box is sealed					
	No abnormal noise and jerky movements from platform control box					
	Joysticks and movement switches return to neutral					
<b>Work Platform. Floor, guardrails, access and extensions</b>						
	No cracks, broken weld, paint chipped					
	No deterioration and visible damage					
	Harness anchor points are not cracked or damaged, with the decal attached and legible					
	No screws missing / loose parts					
	Entry bar/gate closes automatically and is not prevented from closing.					
	Folding guard-rail (if fitted) is fixed securely in position					
<b>Lift assembly (jib, boom, mast, arm, turret)</b>						

# C - Pre-operation inspection

No cracks, broken weld, paint chipped					
No deterioration and visible damage					
No screws missing / loose parts					
No foreign body in joints or slides					
Presence of securely fitted maintenance devices (safety stand)					
All compartments covers open and lock properly					
<b>Frame, axle, steering system, stabilizers arms ...</b>					
No cracks, broken weld, paint chipped					
No deterioration and visible damage					
No screws missing / loose parts					
No foreign body in joints or slides					
Condition of tires/tyres (wear, cutting, damage ...)					
Wheel reducer is undamaged and operates smoothly					
All compartments covers open and lock properly					
<b>Rotation system : orientation turret, basket and jib</b>					
No cracks, broken weld, paint chipped					
No deterioration and visible damage					
No screws missing / loose parts					
No foreign body in joints or slides					
Exterior gear wheel greasing					
Pin, pin stop, bearing ...					
Presence of the turret pin and its locking device					
No bent, cracked or broken pins, pin stops, bushes or bearings					
<b>Cylinder and hydraulic component : pumps, filters, manifold</b>					
No leaks on the pump, tank or fittings					
No deformation, visible damage, broken weld or leaks on hydraulic cylinder					
No screws missing / loose parts					
Presence and operation of hydraulic filter (no clogged)					
Check hydraulic oil level is above the minimum level (Machine folded)					
<b>Energy storage and motorisation: tanks, batteries and engine</b>					
Engine oil level (add in stowed position)					
Fuel level (add in stowed position)					

# C - Pre-operation inspection

No screws missing / loose parts					
Presence and good condition of hydraulic hose					
Presence and good condition of engine components					
Presence and good condition of the batteries: terminations and clamps, electrolyte level ...					
<b>Electric cables</b>					
No torn or split wire sheaths					
No evidence of chemical damage or corrosion on all cables					
No oxidation or corrosion on terminals					
Sensors and safety device					
Stabilizers operate correctly and lock securely in position					
Slope limiting device operates properly					
Axle locking device operate properly					
Pothole safety device operate properly (if equipped)					
Test of load sensing system (visual warning at control box)					
Serial number : Hours of operation : HAULOTTE Services® contract reference : Intervention record number : Date : Name :	Model :  Signature :				

A

B

C

D

E

F

G

H

I

# C - Pre-operation inspection

## 4 - Safety functional checks

To protect the user and the machine, safety systems prevent the movement of the machine beyond its operating limits. These safety systems when activated immobilize the machine and prevent further movement.

The operator must be familiar with this technology and understand that is not a malfunction but an indication that the machine has reached an operation limit.

Aerial Work platforms are equipped with two control boxes which allow operators to safely use the machine. An auxiliary device (overriding system) is available on ground control box when primary power source fails. Each control box is equipped with an E-Stop button, which cuts all movements when pushed in.

The following checks describe the operation of the machine and the specific controls required.

For the location and description of these controls :  refer to section B 3.2 and D 2 Ground control box and B 3.3 and D 3 Platform control box.

### 4.1 - E-STOP BUTTON CHECK

#### Ground control box E-stop button

Step	Action
1	Pull both E-Stop buttons ( 15 ) at ground box and ( 46 ) at platform box.
2	Set the ON/OFF key switch ( 18 ) at ground box to the ON position.
3	Turn the selector switch ( 229 ) knob to the right to energize the ground control box. LED's ( 1 - 10 ) on the display will light up.
4	Start the engine by moving the enable/auxiliary power switch ( 228 ) upwards.
5	Push the E-stop button ( 15 ).
6	Check that the engine stops running.
7	No movements are functional.

#### Platform control box E-stop button

Step	Action
1	Pull out the E-Stop button ( 15 ) at ground box.
2	Set the ON/OFF key switch ( 18 ) at ground box to the ON position.
3	Turn the selector switch knob ( 229 ) at ground box to the left to energize platform box.
4	Pull out the E-Stop button ( 46 ) at platform box.
5	Start the engine from platform using Start/Stop switch ( 230 ).
6	Push in E-Stop button ( 46 ) at platform.
7	Check that the engine stops running.
8	No movements are functional.

# C - Pre-operation inspection

## 4.2 - ACTIVATION OF CONTROLS

The enable switch must be active to allow all movements.

The "Enable Switch" system depends on the machine configuration and will consist of one of the following :

- Joystick trigger at platform box (if fitted).
- Foot pedal switch in the basket.
- Enable switch at ground box.

## 4.3 - FAULT DETECTOR

The machine is equipped with an on-board fault detection system, which indicates the type of fault to the operator.

The fault is identified by a default code.

The default code is displayed at the ground control box.

According to the type of fault, the machine MAY switch into DOWNGRADEMODE and certain movements are prevented to maintain Operator's safety.

Do not use the machine until the fault has been corrected.

### 4.3.1 - Indicators/LED's test

#### From the ground control box

Step	Action
1	Pull both the E-Stop buttons ( 46 ) at platform box and ( 15 ) at ground box.
2	Set the ON/OFF key switch ( 18 ) to ON position.
3	Check that the LED's ( 1 - 10 ) light up on the display box.
4	Check that the LED's on the display are all turned off after 1 sec.

#### From the platform control box

Step	Action
1	Pull E-Stop button ( 15 ) at ground box.
2	Turn the ON/OFF key switch ( 18 ) at ground box to ON position.
3	Turn the energizing selector switch ( 229 ) to the left to energize platform control box.
4	First push in the E-Stop button ( 46 ) at platform box, then pull out.
5	Check that the LED's ( 101 - 117 ) light up on the platform display panel.
6	Check that the LED's ( 101 - 117 ) on the display are all turned off after 1 sec.

### 4.3.2 - Buzzers test

#### From the ground control box

Step	Action
1	Pull both E-Stop buttons ( 15 ) at ground box and ( 46 ) at platform box.
2	Set the ON/OFF key switch ( 18 ) to ON position.
3	Buzzers at ground and platform will beep.

# C - Pre-operation inspection

## 4.4 - AUTOMATIC ENGINE CUT-OUT

The engine automatically cuts out in the following conditions :

- The alternator is not functioning.
- Engine temperature is too high.
- Oil pressure is too low.
- E-Stop(s) are pushed in.
- The machine is switched off.

## 4.5 - OVERLOAD SENSING SYSTEM (IF FITTED)

If the platform load exceeds the maximum allowed load, no movement is possible from the 2 control boxes.

At ground and platform control boxes a buzzer sounds and an indicator light warns the operator

To return the machine to normal operation remove weight from the platform until the load is below the maximum allowed load.

Daily check that the LED's illuminate when the machine is switched on :

- Verify that the Overload system is active : Refer to Indicators ( 6 ) at ground and ( 30 ) at platform.
- Verify that the buzzers are functioning : Refer to Buzzers test

A periodic inspection of this device must be performed according to the recommendation in Maintenance Schedule.

## 4.6 - OSCILLATING AXLES (IF EQUIPPED)

To improve the driving capability on rough terrain, the front axle is equipped with an oscillating mechanism. When the extending structure is retracted and is in the stowed position, oscillating mechanism is unlocked to adapt itself to the features of ground operation. When the extending structure is out of the stowed position, a safety device locks the oscillating mechanism to reduce overturning hazard.

A visual inspection must be performed each day to ensure the absence of leaks from the oscillating cylinder and associated plumbing connections including the hydraulic hoses.

A periodic inspection of this device must be performed according to the recommendation in the maintenance schedule.

# C - Pre-operation inspection

## 4.7 - SLOPE WARNING DEVICE

From each control box, a buzzer alerts the operator that the machine is not folded/stowed and is positioned on a slope exceeding the slope allowed.

***N.B.-:-THE SLOPE SENSOR IS ONLY ACTIVE WHEN THE PLATFORM IS NOT IN THE STOWED POSITION.***

When machine is on a slope greater than the rated slope, with extending structure out of the stowed position, DRIVE function is disabled (For CE, AS and CSA only).

All the lifting movements are cut. Only the lowering movements are authorized.

In this case, fully lower the platform and reposition the machine on level ground before raising the platform again.

To restore DRIVE function, perform the following steps before repositioning on level ground : ➔

### Machine on slope with the platform uphill

Step	Action
1	Retract the upper boom.
2	Lower the bottom arm.
3	Lower the upper boom

### Machine on slope with the platform downhill

Step	Action
1	Lower the upper boom.
2	Lower the top arm.
3	Retract the upper boom.

### To check the tilt sensor at ground level

Step	Action
1	Open the right hand compartment cover (Component location diagrams) and locate the tilt sensor ( C28 ).
2	Pull both E-Stop buttons; ( 15 ) at ground box and ( 46 ) at platform box.
3	Set the ON/OFF key ( 18 ) switch to ON position.
4	Turn the selector switch ( 229 ) knob to the right to energize ground control box.
5	Start the engine by moving the enable/auxiliary power switch ( 228 ) upwards
6	Stow the extending structure by retracting the telescope boom using switch ( 9 ), boom raise/lower switch ( 10 ) and arm lifting switch ( 12 ).
7	Raise the boom to more than 10 degrees above horizontal using the raise/lower switch ( 10 ).
8	While manually tilting the sensor ( C28 ), move it towards the front and hold.
9	Check that the audible beep sounds.

# C - Pre-operation inspection

## 4.8 - TRAVEL SPEED LIMITATION

The machine has a selector of 3 driving speeds - low, medium and high.

All driving speeds are authorised when extending structure of the machine is in stowed position (transport configuration). Drive speed is proportional to the movement of the drive joystick ( 33 ). Adjust position of Jib to enhance field of vision during driving.

When the machine is elevated, drive speed is automatically reduced, regardless of the drive speed chosen.

Daily check that the speed is limited to less than 1 km/h (0.6 mph) when :

- The boom is raised by more than 10° above horizontal.
- The boom is telescoped/extended more than 400 mm (16 in.).
- The arm is raised by more than 2 m (6 ft 7 in) above horizontal.

# D - Operation instructions

## 1 - Operation

### 1.1 - INTRODUCTION

Aerial Work platforms are equipped with two control boxes which allow operators to safely use the machine.

An auxiliary device is available at the ground control box to assist in the rescue of people in an emergency.

Each control box is equipped with an E-Stop button, which allows operators to stop all movements, if necessary.

Only trained and authorized personnel shall be permitted to operate this aerial work platform.

Prior to operation :

- Read, understand and obey all instructions and safety precautions in this manual and attached to the aerial work platform.
- Read, understand and obey all Federal, State and local codes and regulations.
- Become familiar with the proper use of all controls and emergency systems.

### 1.2 - OPERATION FROM THE GROUND CONTROL BOX

- Turning "ON" and "OFF" of the machine is performed with selector key switch (18).
- Activation of a desired control box is achieved by turning the control box energizing selector switch ( 229 ) to the desired position.
- The ground control box is energized and is active ONLY when :
  - The E-stop buttons on both ground and platform control boxes are not pressed in (Deactivated).
  - Machine is switched on by turning ON/OFF selector key switch ( 18 ) at the ground control box to ON position.
- An E-Stop button at each control box stops all movements when pressed in; including shutting off an engine (if equipped).

***N.B.-:-DO NOT TURN OFF THE POWER SUPPLY OF THE MACHINE USING THE E-STOP BUTTON(USE ONLY IN CASE OF EMERGENCY). TURN OFF THE POWER SUPPLY OF THE MACHINE USING THE CONTROL ON/OFF ( 18 ) FROM THE GROUND CONTROL BOX.***

- An enable switch ( 228 ) is present that should be activated and maintained to authorize one or more movements. If enable switch ( 228 ) is kept engaged without selecting a function movement for more than 8 s; enable switch is automatically de-activated
- The release of control box enable switch while performing a movement stops all the movements. The function movement is progressively slowed down. If the enable switch is re-pressed, the function movement does not restart. The function movement can only be selected when the corresponding function switch or joystick is returned to neutral position.
- All switches and joystick operating a movement, return automatically to neutral when released.
- At power up, all switches and joysticks must be in their neutral position.
- Enable switch / back-up unit selector switch ( 228 )
  - With engine running, the selector switch functions as an "enable switch" only.
  - With engine stopped, the selector switch functions as the "enable switch" and allows the back-up unit (emergency pump) functioning.

# D - Operation instructions

- Overriding system : The ground control box is designed for maintenance and emergency rescue operations only. Refer to  Section D 4.2 To rescue operator in platform. .
  - The status of the switches is tested automatically when the machine is switched on. A switch will be active only after it has been detected to be in neutral position. The following switches are not controlled :
    - Accelerator: engine rpm
    - Beacon light (if fitted)
  - A switch provides the start and stop of the engine.
  - Engine speed (If fitted) : This switch increases the engine rpm to the maximum speed.
  - A buzzer beeps in the following conditions :
  - When power is switched on.
    - Overload (if fitted).
    - When machine is on a slope greater than the rated slope.
    - Hydraulic oil overheating.
    - Movements option.
    - Driving option.
  - Indicators / Cluster : All indicators ( LEDs 1-10 ) are checked when the machine is powered on
- For the US destined machines :**
- The fuel selection (petrol or liquid propane gas) is done by turning the switch ( 44 ) to the desired position.

# D - Operation instructions

## 1.3 - OPERATION FROM THE PLATFORM CONTROL BOX

- The platform control box is energized only when :
  - The E-stop buttons on both ground and platform control boxes are not pressed in.
  - Machine is switched on by turning ON/OFF selector key switch ( 18 ) at the ground control box to ON position.
  - Platform control box is energized by turning the control box energizing selector switch ( 229 ) at the ground control box to the left.
  - Overriding system not activated.
- A faulty joystick is not taken into account to control a movement. If this fault disappears, the movement is authorised again.
- An E-Stop button at each control box stops all movements when pressed in; including shutting off an engine (if equipped).

***N.B.-:-DO NOT TURN OFF THE POWER SUPPLY OF THE MACHINE USING THE E-STOP BUTTON(USE ONLY IN CASE OF EMERGENCY). TURN OFF THE POWER SUPPLY OF THE MACHINE USING THE CONTROL ON/OFF ( 18 ) FROM THE GROUND CONTROL BOX.***

- A foot pedal switch is present that should be activated and maintained to authorize one or more movements. If foot pedal switch is kept engaged without selecting a function movement for more than 8 s; foot pedal switch is automatically de-activated.
- The release of foot pedal switch while performing a movement, stops that function movement and all other movements are inactive. The stop of movements is progressive. If the "Enable switch" is pressed again quickly within 0,5 s the movement restarts. If the "Enable switch" is not pressed again quickly enough within + 0,5 s the movement will not restart. It could restart only when the selected function switch/joystick is released to neutral position.
- All switches and joystick operating a movement, return automatically to neutral when released.
- At power up, a switch in it's neutral position will be taken into account to authorize movement.

### **For the US destined machines :**

- The fuel selection (petrol or liquid propane gas) is done by turning the switch ( 44 ) to the desired position.
- The status of the switches is tested automatically when the machine is switched on and checked at every starting. A switch will be activated only after it has been detected in neutral position.
- A buzzer beeps in the following conditions :
  - When power is switched on.
  - When platform is overloaded (if fitted).
  - When machine is on a slope greater than the rated slope.
- Emergency pump. (  Section D 4.1 In case of engine power failure)
- Indicators - All indicators (LEDs 101 - 117) are checked when the machine is powered on

## 1.4 - OPERATION OF OVERRIDING SYSTEM FROM GROUND CONTROL BOX



Please refer to paragraph  D.4.2 To rescue operator in platform.

# D - Operation instructions

## 2 - Ground control box

### 2.1 - TO START AND STOP THE MACHINE - DIESEL ENGINE

- Check that the E-stop buttons ( 15 ) at ground control box and ( 46 ) at platform control box are not pressed in.
- Turn ON / OFF key switch ( 18 ) to the right to turn ON. The LED display panel comes on.
- Turn the control box selector ( 229 ) to the right to select ground control box.
- Push the starter selector ( 228 ) upwards. The engine starts. The indicator goes out.
- Let the engine heat up.

#### **To shut-down the machine from the ground control box :**

- Push the starter selector ( 228 ) upwards. The engine stops.
- Turn the key switch ( 18 ) to the OFF position.
- The machine is now switched off.

***N.B.-:THIS OPERATION TURNS THE MACHINE OFF AND IT IS REQUIRED TO PREVENT BATTERY DISCHARGE.***

### 2.2 - TO START AND STOP THE MACHINE - PETROL / GAS (PROPANE) ENGINE

- Open the gas bottle valve.
- At the ground control box, check that the E-stop button ( 15, 46 ) is not pressed.
- Turn the petrol/liquid propane gas selector ( 44 ) into LPG position
- Turn ON / OFF key switch ( 18 ) to the right to turn ON. The LED display panel comes on.
- Turn the control box selector ( 229 ) to the right to select ground control box.
- Push the starter selector ( 228 ) upwards. The engine starts. The indicator goes out.
- Let the engine heat up.

#### **To shut-down the machine from the ground control box :**

- Push the starter selector ( 228 ) upwards. The engine stops.
- Turn the key switch ( 18 ) to the OFF position.
- The machine is now switched off.

***N.B.-:THIS OPERATION TURNS THE MACHINE OFF AND IT IS REQUIRED TO PREVENT BATTERY DISCHARGE.***

- Close the gas bottle valve



If the gas bottle is empty, the engine stops. Turn the petrol/liquid propane gas selector ( 44 ) into Gasoline position. Restart the engine.

# D - Operation instructions

## 2.3 - BOOM AND ARM CONTROLS

Platform leveling is available, regardless of the work height. Even at low movement speeds, use the controls with caution.

**N.B.-:-RELEASING THE ENABLE SWITCH (FOOTPEDAL ) WILL STOP ALL MOVEMENTS.**

### Ground box controls (emergency station)

Control	Action
Lifting / lowering of boom	Push the boom raising switch ( 10 ) upwards to lift the boom.
	Push the boom raising switch ( 10 ) downwards to lower the boom.
Lifting/lowering of arm	Push the arm lift/lower selector ( 12 ) upwards to raise the arm.
	Push the arm lift/lower selector ( 12 ) downwards to lower the arm.
Boom telescope extend/retract	Push the boom telescoping switch ( 9 ) to the left to extend the boom.
	Push the boom telescoping switch ( 9 ) to the right to retract the boom.
Jib lifting/lowering (If applicable)	Push the jib switch ( 8 ) upwards to lift the jib.
	Push the jib switch ( 8 ) downwards to lower the jib.
Turntable rotation	Push the turntable rotation switch ( 14 ) to the right for a clockwise (CW) rotation.
	Push the turntable rotation switch ( 14 ) to the left for a counter clockwise (CCW) rotation.

# D - Operation instructions

## 3 - Platform control box

### 3.1 - TO START AND STOP THE MACHINE

#### To start the machine :

##### *At the ground control box :*

- Check that the E-stop button ( 15 ) is not pressed in.
- Turn ON/OFF key switch ( 18 ) to the right to turn ON.
- Turn the control box energizing selector switch ( 229 ) to the left to energize platform box.

##### *At the platform control box :*

- Check that the E-stop button ( 46 ) is not pressed in.
- Push the starter selector switch ( 230 ) upwards. During pre-heating LED ( 102 ) at platform display panel and LED ( 5 ) at ground display panel will light up. Pre-heating begins and the engine starts.
- Allow the engine to heat up and initialize.

#### To stop the engine :

- Push engine start switch ( 230 ) upwards.

# D - Operation instructions







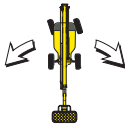

## 3.2 - DRIVE AND STEER CONTROL

To activate drive and steer function, press the foot pedal switch and simultaneously operate the joystick ( 33 ) for the desired function.

Before driving, locate the green / red orientation arrows on the chassis and platform controls.

Move the drive control joystick ( 33 ) in the direction matching the directional arrows.

**N.B.-:ON UNEVEN TERRAIN, LOWER THE BOOM TO IMPROVE THE DRIVE PERFORMANCE.**

Control	Action	
Steering		Press thumb/rocker switch on joystick ( 33 ) to the right to steer right.
		Press thumb/rocker switch on joystick ( 33 ) to the left to steer left.
Driving		Move joystick ( 33 ) forwards for the machine to travel in the forward direction.
		Pull joystick ( 33 ) backwards for the machine to travel in the reverse direction.
Drive speed		Position the drive speed selector switch ( 45 ) on  for high-speed driving.
		Position the driving speed selector ( 45 ) on  for medium speed driving (crossing uneven ground, slope).
		Position the driving speed selector ( 45 ) on  for low-speed driving (short distance, final approach, unloading from lorries/trucks).

# D - Operation instructions

## 3.3 - BOOM AND ARM CONTROLS

Activate the desired control and the enable switch (foot pedal switch) simultaneously to perform that selected function.

### Foot pedal switch

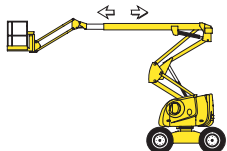
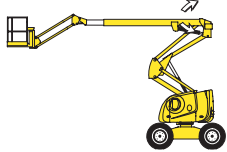
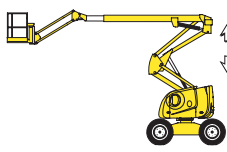
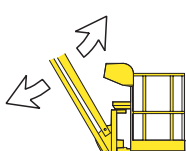

Control	Action
Boom telescope extend/retract 	Push the boom telescoping switch ( 54 ) upwards to retract the boom. Push the boom telescoping switch ( 54 ) downwards to extend the boom.
Lifting / lowering of boom 	Move the boom/turntable joystick ( 49 ) forward to raise the boom. Move the boom/turntable joystick ( 49 ) backwards to lower the boom.
Lifting/lowering of arm 	Push the arm joystick ( 50 ) forwards to raise the arm. Push the arm joystick ( 50 ) backwards to lower the arm.
Jib lifting/lowering 	Push the jib switch ( 129 ) upwards to lift the jib. Push the jib switch ( 129 ) downwards to lower the jib.

# D - Operation instructions

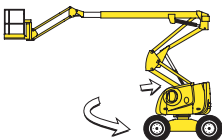
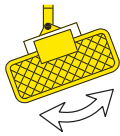
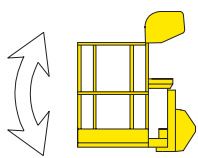
Control	Action
Turntable rotation 	Move the boom/turntable joystick ( 49 ) to the left for a clockwise (CW) rotation. Move the boom/turntable joystick ( 49 ) to the right for a counter clockwise (CCW) rotation.
Platform rotation 	Move the platform rotation selector ( 38 ) to the right for a counter clockwise (CCW) rotation. Move the platform rotation selector ( 38 ) to the left for a clockwise (CW) rotation.
Platform leveling 	Move the platform leveling switch ( 40 ) upwards to raise the platform. Move the platform leveling switch ( 40 ) downwards to lower the platform.

## 3.4 - ADDITIONAL CONTROLS

- Horn : Push the horn selector ( 43 ) to the right to sound the horn. The horn stops when the selector switch is released.

# D - Operation instructions

## 4 - Emergency procedure

### 4.1 - IN CASE OF POWER LOSS

In case of loss of the main power source, the secondary (back-up) power unit, powered by the starting battery, allows movements to be controlled from both the ground and platform control boxes.

As the electric pump has limited power, it is advisable to reach the ground in the most direct manner possible.

The use of the electric pump is exclusively reserved for lowering the boom in emergency situations only. It is recommended to first retract the boom before lowering the boom. Performing other operations can lead to the deterioration of the electric pump.

***N.B.:-TEST THE OPERATION OF EMERGENCY SYSTEM ATLEAST ONCE A MONTH. REFER TO THE MAINTENANCE MANUAL***

Depending on the control box in use, push and hold the back-up/auxiliary power switch ( 228 ) at ground box or switch ( 41 ) at platform box. Retract the boom and lower it by using switches ( 9 ) and ( 10 ) at ground box or switch ( 54 ) and joystick ( 49 ) at platform box.

In an emergency, if the operator has to exit the platform while it is elevated, the transfer of the operator must respect the following recommendations. :

- Exit onto a sturdy and safe structure.
- The occupant(s) must ensure that 2 lanyards are used for security/safety. One must be attached to the designated anchorage point on platform the occupant(s) is in and the other attached to the structure intended to get on.
- Occupant(s) must exit the current platform through the normal access.

***N.B.:-DO NOT DETACH THE LANYARD FROM THE CURRENT PLATFORM IF THE TRANSFER TO THE NEW STRUCTURE POSES ANY DANGER OR UNTIL THE TRANSFER IS SAFELY COMPLETED. DO NOT ATTEMPT TO CLIMB DOWN THE BOOM. INSTEAD WAIT FOR ASSISTANCE FOR A SAFE EXIT.***

# D - Operation instructions

## 4.2 - TO RESCUE OPERATOR IN PLATFORM

In a situation where an operator located in the platform needs to be rescued (for example in case of illness, injury or trapped against a structure making the control box inaccessible), the rescue personnel at ground level needs to obtain rapid and direct access to operating functions.

HAULOTTE® provides a ground control emergency system that should be used to safely bring the operator into such a position that appropriate medical attention could be provided.

Unlike the ground control box used in lowering the boom, the overriding system allows trapped occupant(s) to be lowered to the ground level, even if an E-Stop is engaged or if an overload is detected.

In this situation, supervisor(s) at ground level must turn the control box selector ( 229 ) to the "right" on the ground control box to take control. To safely activate movements from the ground control box, the enable switch ( 228 ) must be held activated/depressed.

### Procedure :

- Turn the control box selector ( 229 ) to the "right" to energize the ground control box.
- The platform box controls are now de-energized.
- Check that the E-Stop button ( 15 ) at ground is not pressed in.
- To lower the platform, hold enable switch ( 228 ) downwards and simultaneously push the desired function switch.
- If the platform E-stop button ( 46 ) or a safety device does not allow normal movement from the ground control box, the overriding system is operated as follows :
- Break the seal on "overriding system" switch ( 245 ) on the ground control box.
- Simultaneously, push upwards and maintain overriding switch ( 245 ) in addition to desired movements actuator to obtain movement of the extending structure.

***N.B.-:-OPERATION OF THE "OVERRIDING SYSTEM" SWITCH MUST BE AN EXCEPTION AND NOT A NORMAL EMERGENCY OPERATION.***

# D - Operation instructions

## "Overriding system" switch under sealed cover

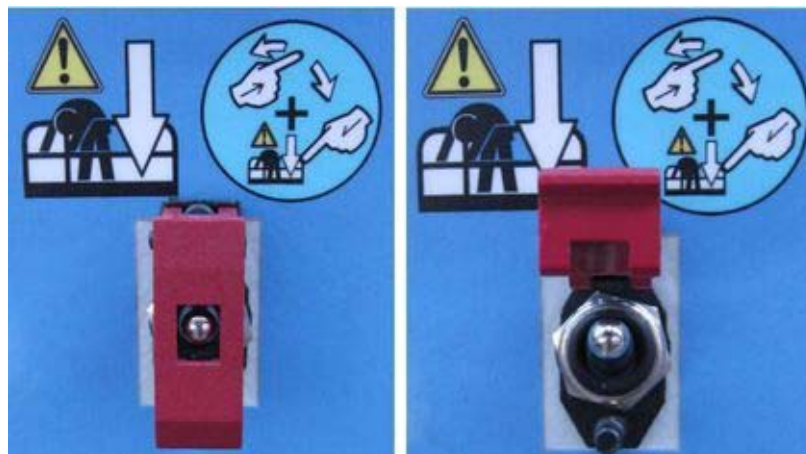

Once rescue operations are complete, report the incident and put a new seal. **IMPORTANT** : if the seal is missing, this is considered to be abnormal use of the machine.

### 4.3 - NO POWER AVAILABLE

In case of loss of the main power and the secondary power unit not functioning, do not attempt to activate any function movement using hydraulic manifold unless trained and authorized by HAULOTTE Services®. All safety functions are no longer active and several hazards may occur. Improper use of the equipment will result in death or serious injuries.



If the operator cannot be lowered by any of the above mentioned methods, contact HAULOTTE Services® immediately.

# D - Operation instructions

## 5 - Transportation

### 5.1 - PUTTING IN TRANSPORT POSITION

To avoid any risk of machine movement during loading, ensure that :

- The loading ramp can support the machine weight.
- The loading ramp is correctly attached to transport vehicle.
- The loading ramp has sufficient grip surface.
- The transport vehicle must be parked on a level surface and must be secured to prevent rolling away while machine is being loaded or unloaded.

To climb the slope, select low driving speed.

If the slope is too steep, use a winch in addition to the low speed drive.

Do not place yourself below or too close to the machine during loading.

A wrong move can lead to machine tipping over and may cause serious injuries and material damage.

The machine must be completely in the stowed configuration :

- Check the platform is completely empty.
- Lower the boom and drive onto the truck bed.
- Secure the machine to the tie down points provided (See picture).
- Lock the turntable with the rotation stop pin located under the turntable before transporting.
- The platform/basket must be chocked and the boom strapped to prevent bouncing up and down, thus preventing possible material damage during transporting.
- Do not use excessive downward force when securing boom section.

# D - Operation instructions

## 5.2 - MACHINE LAYOUT

Turret rotation enabled



Turret rotation disabled



Machine stowing

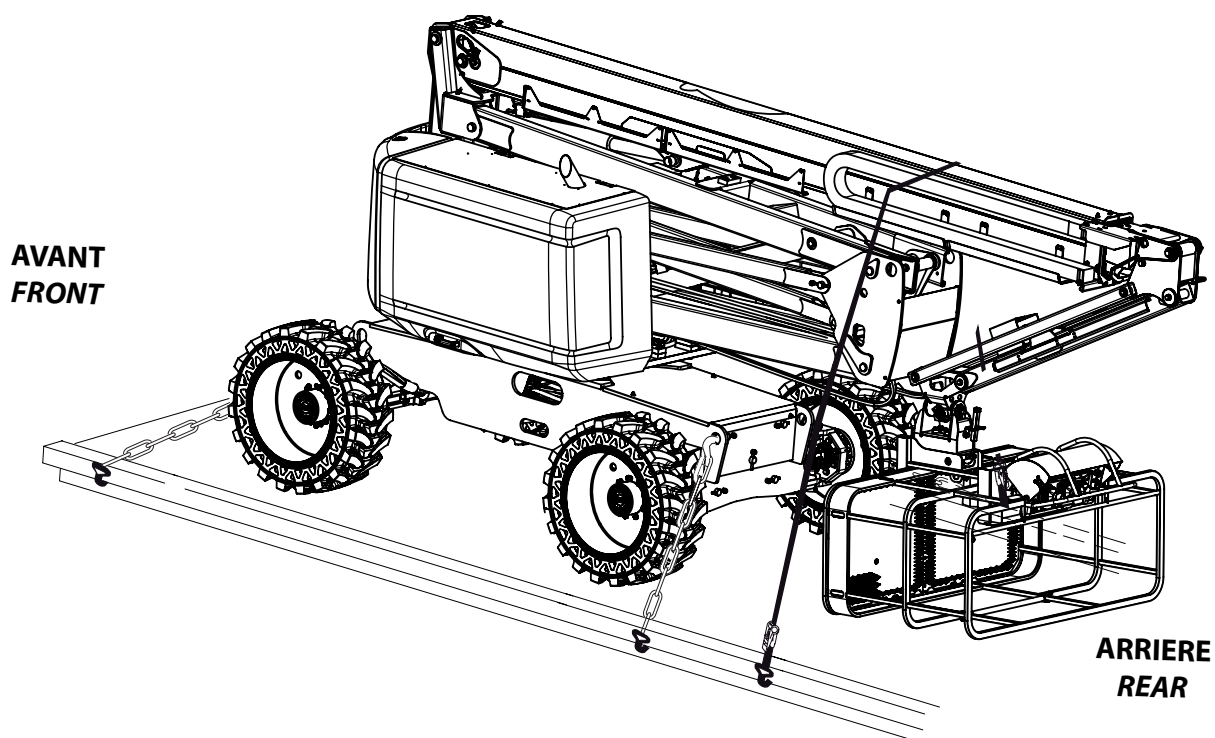

***N.B.:-SECURE TURNTABLE WITH THE TURNTABLE LOCKING PIN BEFORE TRAVELING LONG DISTANCES OR HAULING MACHINE ON A TRUCK.***

# D - Operation instructions

## 5.3 - UNLOADING

Before unloading, check that the machine is in good condition.

- Remove the turntable rotation locking pin.
- Remove the tie downs.
- Select low drive speed at the platform control box.
- Start the machine.



**Warning :** Upon starting a machine that has been secured and transported, the safety system may detect a false overload preventing all movement from the platform control box.

To reinstate the system, lift the jib a few centimetres (inches) using the ground control box.

A

B

C

D

E

F

G

H

I

# D - Operation instructions

## 5.4 - TOWING



In the event of a machine breakdown, the machine can be towed a short distance to load it onto a transport vehicle :

- Ensure that no one is in the platform during towing.
- Ensure boom is in the stowed position and the turntable is locked, prior to towing.
- The platform must be empty.

To tow a broken-down machine, disconnect the wheel drive hubs.

Perform this operation on flat ground with wheels chocked.

In the towing configuration, the machine braking system is inactive. Use a drawbar to avoid any risk of accident :

- Do not exceed the maximum speed (machine unfolded) (Refer to  Section B 4 Technical specifications).
- Do not exceed a grade of 45%.

### 5.4.1 - Disengaging the drive hubs

- Use an 11 spanner to undo and remove the 2 screws from the plate.



- Remove the plate, turn it over and fix it in place using the 2 screws you removed previously.

***N.B.-:-THE PLATE BOSS WILL PUSH THE SPRING IN. THE DRIVE HUBS ARE NOW DISENGAGED.***



# D - Operation instructions



When drive hubs are disengaged, the machine is in free wheel mode and the brake system no longer functions.

## 5.4.2 - Re-engaging the drive hubs

- Perform in reverse order to the drive hub disengaging procedure



Carry out a few driving movements. The drive hubs are now re-engaged.

Machine is now in the normal driving mode.

## 5.5 - STORAGE

When the machine is in elevated position, it is necessary to regularly switch the power ON to ensure that the security systems are active.

Machine must be parked in a protected/designated area with the boom in a stowed configuration, however the boom can be raised but must not be extended. Make sure there is no load in the platform.

It is recommended that the machine is not stored or immobilized unfolded; to avoid jeopardizing the safety of people and property.

Ensure all access panels, doors and side compartment covers are shut and secured.

Turn the On/OFF selector key switch ( 18 ) at the ground control box to the "left" to shut OFF the power.

Ensure that the turntable rotation locking pin is removed and stored properly.

Remove the key switch to prevent unauthorized operation of the machine.



Storing of the machine with an obstacle under the boom structure is forbidden.

A

B

C

D

E

F

G

H

I

# D - Operation instructions

## 5.6 - LIFTING OPERATION

During loading / unloading operation, if it becomes necessary to lift the machine using an overhead crane, it is important to respect the following :

- Put the machine in stowed position, boom and arm fully retracted and lowered.
- Ensure the platform is empty.
- Rotate the turret and the jib to the configuration in the photos below.
- Lock the turret with turret locking pin.
- Verify that lifting accessories are in good operation and match the technical specifications listed below. It is important that the lifting devices are attached only to the designated lifting eyes.
- Each of the chains/slides used for lifting the machine must be adjusted to keep the machine level and to minimize the risk of damage to the machine.

- Anchorage point for lifting are identified / labeled by the following symbol .

- ONLY trained and authorized personnel should attempt to lift the machine.



Never lift the machine with slings attached to counterweight.

### Procedure for the use of slings

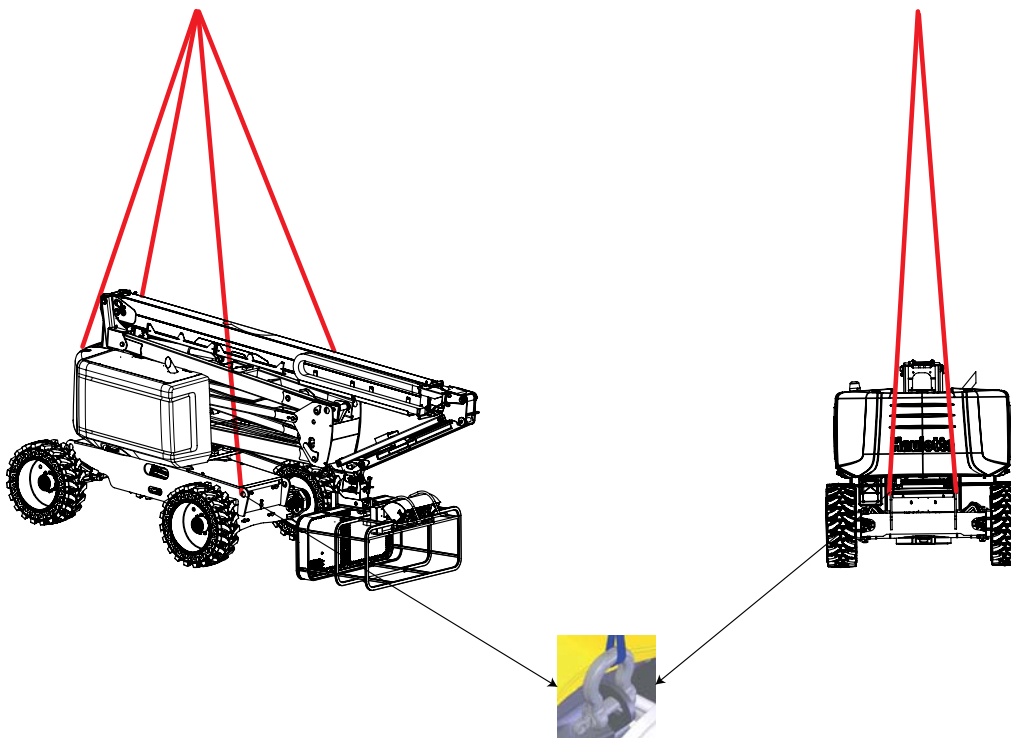

	Number of shackles	Number of slings	Length	Maximum load per sling and shackle
A	4	4	5 m (16 ft 5 in)	3000 daN (6744 lbf)

# D - Operation instructions

## 6 - Cold Weather Recommendations

In cold weather conditions, allow engine to run for at least 5 min and warm up ; before operating any function thereby preventing any damage to the hydraulic system.

In extreme cold conditions, machines should be equipped with optional cold start kits.

Attempting to start engine when temperature is in the negative range, may require the use of a booster battery.

If engine fails to start, do not crank for an extended time. Allow starter to "cool off" for a few minutes before attempting again. If engine fails after several attempts, refer to the engine maintenance manual.

***N.B.-:INITIAL STARTING SHOULD ALWAYS BE PERFORMED FROM THE GROUND CONTROL BOX.***

### 6.1 - ENGINE OIL

The correct SAE viscosity grade of oil is determined by the minimum ambient temperature during cold engine start-up, and the maximum ambient temperature during engine operation.

Generally, use the highest viscosity oil that is available to meet the requirement for the temperature at start-up.

EMA LGR-1 / API CH-4 Viscosity grade	Engine oil viscosity	
	Minimum	Maximum
SAE 0W20	-40°C (-40°F)	10°C (50°F)
SAE 0W30	-40°C (-40°F)	30°C (86°F)
SAE 0W40	-40°C (-40°F)	40°C (104°F)
SAE 5W30	-30°C (-22°F)	30°C (86°F)
SAE 5W40	-30°C (-22°F)	40°C (104°F)
SAE 10W30	-20°C (-4°F)	40°C (104°F)
SAE 15W40	-10°C (14°F)	50°C (122°F)

***N.B.-:FOR ADDITIONAL ENGINE RECOMMENDATION, REFER TO THE ENGINE MANUAL PROVIDED WITH THE MACHINE.***

# D - Operation instructions

## 6.2 - HYDRAULIC OIL

External environmental conditions can reduce performance of the machine if the hydraulic oil temperature does not reach its optimum range.

It is recommended to use the hydraulic oil according to weather condition. Refer to the table below.

Environmental conditions	SAE Viscosity grade
Ambient temperature between - 15°C (5°F) and + 40°C (+ 104°F)	HV 46
Ambient temperature between - 35°C (- 31°F) and + 35°C (+ 95°F)	HV 32
Ambient temperature between 0°C (+ 32°F) and + 45°C (+ 113°F)	HV 68

***N.B.-:IT IS RECOMMENDED TO REPLACE LOW TEMPERATURE OIL AS THE AMBIENT TEMPERATURE REACHES + 15°C (59°F). IT IS NOT ADVISABLE TO MIX OILS OF DIFFERENT BRANDS OR TYPES.***

## 6.3 - PREHEATING OPERATION

- Turn the power on by turning the ON/OFF selector key switch ( 18 ) to the right.
- When the start / stop selector switch ( 230 ) at platform control box or ( 228 ) at ground control box is activated, the orange LED ( 5 ) at ground control display panel and LED ( 102 ) at platform control display panel flashes, indicating that the engine is in automatic pre-heating mode.
- Upon the extinction of this light ( 3 s to 15 s ) at ground control box, the engine starts.

# E - General Specifications

## 1 - Machine dimensions

Stowed / Transport position : Configuration that takes the minimum floor space necessary for storage and / or delivery of the machine - Access position.

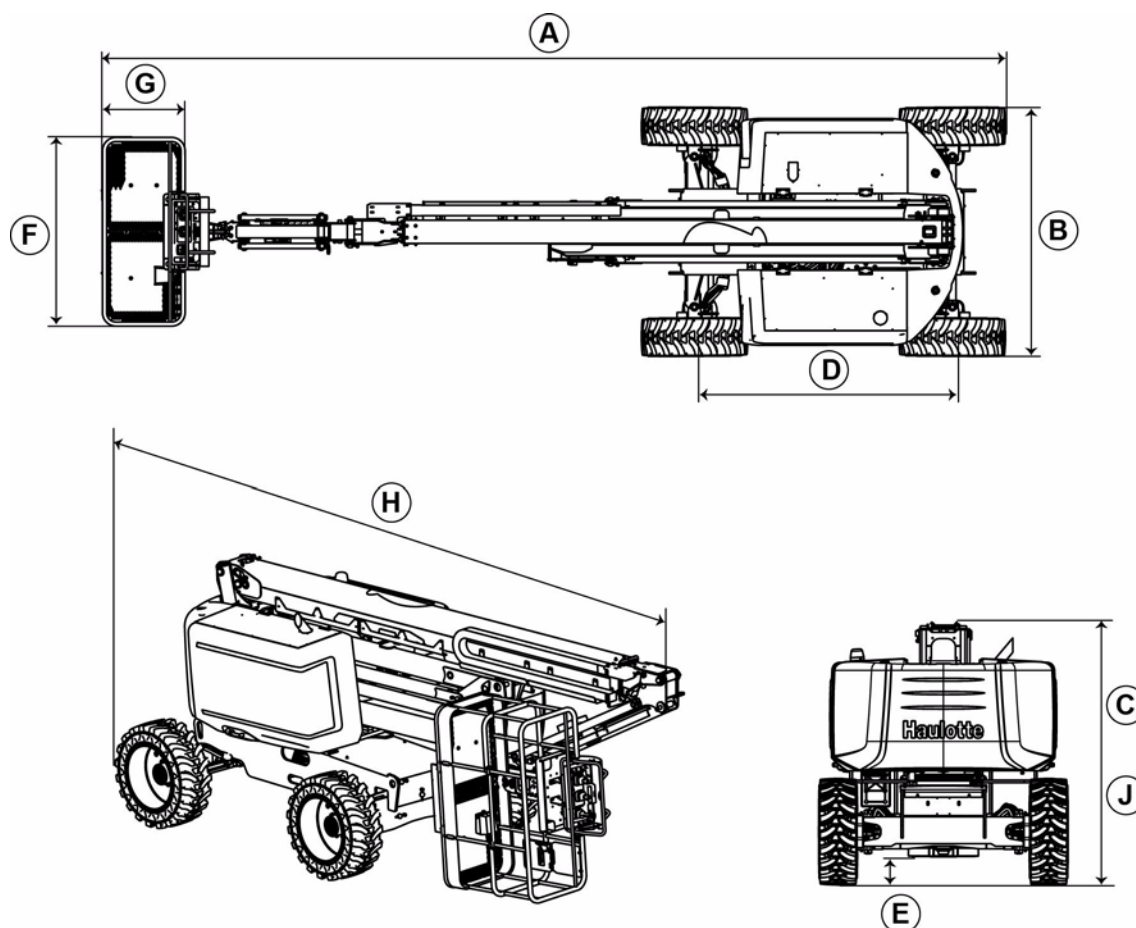

### CE and AS standards

Machine		HA20RTJ		HA20RTJ O	
Marking	Specifications - Dimensions	SI	Imp.	SI	Imp.
A	Overall length of machine	8,80 m	28 ft 10 in	8,80 m	28 ft 10 in
B	Overall width of machine	2,44 m	8 ft 0 in	2,44 m	8 ft 0 in
C	Overall height of machine	2,47 m	8 ft 1 in	2,47 m	8 ft 1 in
D	Wheel base	2,50 m	8 ft 2 in	2,50 m	8 ft 2 in
E	Ground clearance	38 cm	15 in	38 cm	15 in
F X G	Platform dimensions - Standard	1,8 x 0,8 m	5 ft 11 in x 2 ft 7 in	1,8 x 0,8 m	5 ft 11 in x 2 ft 7 in
F X G	Platform dimensions - Option	2,44 x 0,915 m	8 ft x 3 ft	2,44 x 0,915 m	8 ft x 3 ft
H	Storage length	6,50 m	21 ft 4 in	6,50 m	21 ft 4 in
J	Storage height	2,93 m	9 ft 7 in	2,93 m	9 ft 7 in

# E - General Specifications

## CE and AS standards

Machine		HA20RTJ PRO	
Marking	Specifications - Dimensions	SI	Imp.
A	Overall length of machine	8,80 m	28 ft 10 in
B	Overall width of machine	2,44 m	8 ft 0 in
C	Overall height of machine	2,51 m	8 ft 3 in
D	Wheel base	2,50 m	8 ft 2 in
E	Ground clearance	42 cm	15 in
F X G	Platform dimensions - Standard	1,8 x 0,8 m	5 ft 11 in x 2 ft 7 in
F X G	Platform dimensions - Option	2,44 x 0,915 m	8 ft x 3 ft
H	Storage length	6,50 m	21 ft 4 in
J	Storage height	2,93 m	9 ft 7 in

## ANSI and CSA standards

Machine		HA61RTJ O		HA61RTJ PRO	
Marking	Specifications - Dimensions	SI	Imp.	SI	Imp.
A	Overall length of machine	8,80 m	28 ft 10 in	8,80 m	28 ft 10 in
B	Overall width of machine	2,44 m	8 ft 0 in	2,44 m	8 ft 0 in
C	Overall height of machine	2,47 m	8 ft 1 in	2,51 m	8 ft 3 in
D	Wheel base	2,50 m	8 ft 2 in	2,50 m	8 ft 2 in
E	Ground clearance	38 cm	15 in	42 cm	15 in
F X G	Platform dimensions - Standard	1,8 x 0,8 m	5 ft 11 in x 2 ft 7 in	1,8 x 0,8 m	5 ft 11 in x 2 ft 7 in
F X G	Platform dimensions - Option	2,44 x 0,915 m	8 ft x 3 ft	2,44 x 0,915 m	8 ft x 3 ft
H	Storage length	6,50 m	21 ft 4 in	6,50 m	21 ft 4 in
J	Storage height	2,93 m	9 ft 7 in	2,93 m	9 ft 7 in

# E - General Specifications

## 2 - Major component masses

*N.B.-:MASSES MEASURED WITH EMPTY TANKS.*

Component	HA20RTJ	HA20RTJ O - HA61RTJ O	HA20RTJ PRO - HA61RTJ PRO
Frame assembly mass	2 860 kg - 6,306 lbs		2 960 kg - 6,525 lbs
• Wheel mass of each 850 x 340	187kg +/- 4 kg (412 lbs +/- 9 lbs)		NA
• Wheel mass of each 1025 x 365	NA		290 kg +/- 6 kg (639 lbs +/- 13 lbs)
Turret assembly mass	900 kg - 1985 lbs		
• Counterweight mass - Turntable	2 560 kg - 5,645 lbs	2 760 kg - 6,086 lbs	2 560 kg - 5,645 lbs
• Engine compartment mass	400 kg - 882 lbs		
• Battery mass	20 kg - 44 lbs		
Boom assembly mass	750 kg - 1654 lbs		
Arm assembly mass	1 650 kg - 3,638 lbs		
Jib assembly mass	150 kg - 331 lbs		
Platform assembly mass	200 kg - 441 lbs		
Machine mass	9 300 kg - 20,57 lbs	9 500 kg - 20,948 lbs	9 600 kg - 21,168 lbs

# E - General Specifications

## 3 - Acoustics and vibrations

The acoustics and vibrations specifications are based upon the following conditions :

- The airborne noise emissions at workstation are determined per European Directive 2006/42/CE.
- The guaranteed sound power level LWA (displayed on the product) is determined per European Directive 2000/14/CE.
- The vibrations transmitted by the machinery to the hand/arm system and to the whole body are determined per European Directive 2006/42/CE.

Specifications	
Sound pressure level at workstation	80 dBA
Guaranteed sound power level	104 dBA
Vibrations hand/arm	Vibration transmitted by this MEWP to the hand-arm does not exceed 2,5 m/s <sup>2</sup> (98,4 in/s <sup>2</sup> )
Vibrations whole body	Vibration transmitted by this MEWP to the whole body does not exceed 0,5 m/s <sup>2</sup> (19,6 in/s <sup>2</sup> )

# E - General Specifications

## 4 - Wheel/Tire assembly

### 4.1 - TECHNICAL SPECIFICATIONS

Component	Standard wheel HA20RTJ	Standard wheel HA20RTJ O	Standard wheel HA20RTJ PRO
Reference number	4000278720		4000075640
	4000278730		4000075650
Type	Solid Tire (Curred - on)		
Wheel mass	187 kg +/- 4 kg (412 lbs +/- 9 lbs)		290 kg +/- 6 kg (639 lbs +/- 13 lbs)
Size	Solideal 850 x 340		Solideal 1025 x 365
Torque	320 Nm (236 ft lbs)		

### 4.2 - INSPECTION AND MAINTENANCE



The tire and rim are bonded together, both must be replaced if either is damaged.

Wheels replacement must be made in the following cases :

- Deformation or cracks on the rim.
- De-bonding between the interface of the steel and the rubber.
- Uniform wear to the wearing line :
  - 850 x 340 wheel :  $\varnothing$  789 mm / 32 in
  - 1025 x 365 wheel :  $\varnothing$  962 / 38 in
- Non-linear wearing of the tread profile (> 10%)

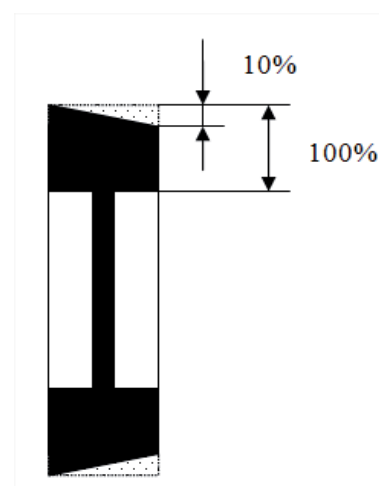

# E - General Specifications

- Linear wear of the thread profile (> 25 %)

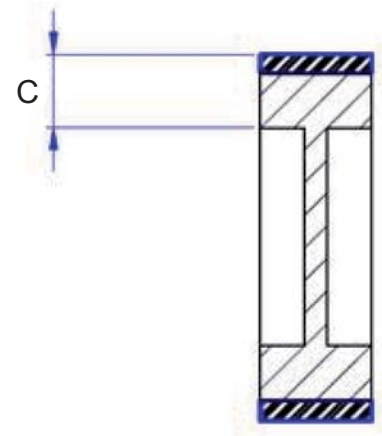

	Standard wheel HA20RTJ	Standard wheel HA20RTJ O	Standard wheel HA20RTJ PRO
New tire	C = 185 mm / 8 in	C = 168 mm / 7 in	C = 168 mm / 7 in
Defective tire (Linear wear of the tread profile > 25 %)	C = 140 mm / 6 in	C = 126 mm / 5 in	C = 126 mm / 5 in

- 1 wheel stud is completely torn.
- 2 successive wheel studs are partially torn.
- 2 aperture holes are cut.



Tires and rims are critical components for the stability of the machine. For safety reasons :

- Use only HAULOTTE® spare parts according to the technical characteristics of the machine. Refer to the spare parts catalog.
- Do not replace factory-installed tires with tires of different specifications or ply rating.
- Never replace a solid (rigid) tire with a foam-filled or a pneumatic (air-filled) tire.

# E - General Specifications

**Procedure of replacement :**

- Loosen the wheel nuts on the wheel to be removed.
- Raise the machine using a jack or a hoist.
- Remove the wheel nuts.
- Remove the wheel.
- Install the new wheel.
- Lower the machine to the ground.
- Tighten the wheel nuts to the recommended torque. Refer to maintenance and repair manuals.

***N.B.-:IF A WHEEL HAS BEEN REPLACED, OBSERVING THE AXLE TRACK PATTERN CHECK FOR CORRECT INSTALLATION.***

A

B

C

D

➤ E

F

G

H

I

# E - General Specifications

## 5 - Options

### 5.1 - ON-BOARD GENERATOR

#### 5.1.1 - Principle

The on-board generator supplies voltage ( 220 V or 110 V depending; on the option) in the basket to connect a power tool.



Check that the maximum power of the tool doesn't exceed that of the generator.



Do not expose the on-board generator to direct contact with a water beam or a high pressure cleaner.

#### 5.1.2 - Procedure

##### Put into service :

1. Start the machine. Heat the engine for 15 mn before any operation.
2. From the platform control box, move the generator selector switch ( ( 79 ) ) to the right to activate the generator
3. Connect the tool to the socket.
4. You can change the tool at any time.

***N.B.-:WHEN USING THE ON-BOARD GENERATOR, YOU CANNOT MAKE ANY MACHINE MOVEMENTS. TO MAKE A MOVEMENT, YOU MUST SWITCH OFF THE ON-BOARD GENERATOR.***

##### Power off :

1. Disconnect the tool from the socket.
2. From the platform control box, activate the selector switch (79) to the right to activate generator.
3. Machine movements are once again functional.

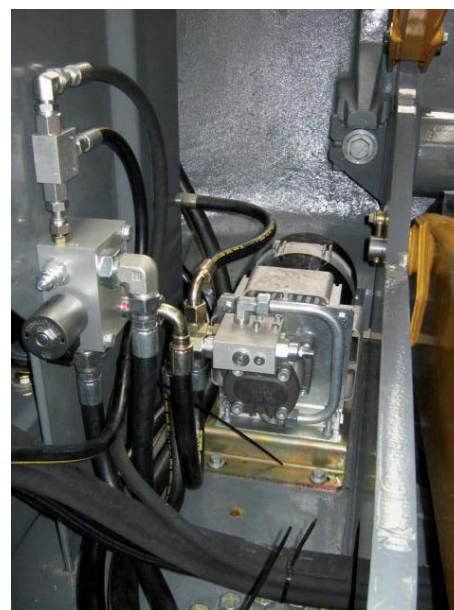

# E - General Specifications

## 5.2 - GLAZIER'S KIT

### 5.2.1 - Description

This attachment is an assembly designed to transport panels. The assembly comprises of a tray that extends along the length of the floor. The panel(s) should be placed in the tray and secured to the guard rail with a strap (not supplied). This tray can be used ONLY with a side entry platform.

### 5.2.2 - Characteristics

Component	Characteristics
Capacity	115 kg (220 lbs)
Mass	10 kg (22 lbs)
Maximum load surface	3 m <sup>2</sup> (32 sq.ft)
Maximum height of the panel	1,20 m (3 ft 11 in)
Maximum wind speed allowed	CE / AS : 12,5 ms - 45 km/h - 28 mph ANSI / CSA: 7 ms - 25 km/h - 15 mph

### 5.2.3 - Safety precautions



- Please read and assimilate the instructions before using the attachment.
- This attachment is designed for transporting panels. Do not use this attachment for transporting other types of load.
- Do not suspend loads.
- Do not overload the attachment and ensure that the equipment is correctly attached by means of a strap (not supplied).
- Do not exceed the maximum allowable platform capacity. The combined weight of the attachment, the panel(s), the occupants, the tools and any other equipment must not exceed the maximum allowable platform capacity.
- Do not load panels whose surface area exceeds the maximum authorized surface area. Exposing an additional surface area to the wind reduces machine stability. Do not install any other attachments that increase the surface area exposed to the wind.
- Check that the position of the panel is not reducing visibility during maneuvers in the work environment. Do not transport panels whose height exceeds the authorized limit.
- When maneuvering, ensure that a safe distance is maintained between the panel and the obstacles in the work environment.
- Do not use the machine if the wind speed exceeds the authorized limit of the attachment.

### 5.2.4 - Pre-operation inspection



- Check that the cradles have no cracks or other damage.
- Check that the cradles are correctly installed and secured to the platform.
- Check that the information decal is present on the cradle and is legible.
- Check that the strap is not twisted or torn.

# E - General Specifications

## 5.2.5 - Operation

- Load the panel onto the platform.
- Securely attach the tray to the guard rail by means of a strap with the correct strength and dimensions for the panel.

### Strapping example(s) - Large panel



### Strapping example(s) - Small panel



# E - General Specifications

## 5.2.6 - Assembly / Disassembly

### Panel carrier



Marking	Description
1	Tray (Panel carrier)
2	Platform
3	Platform carrier
4	Screws and nuts
5	Platform contour tube
6	Hook

- Hook the tray ( 1 ) onto floor contour tube ( 5 ).
- Fix the tray ( 1 ) to the platform carrier ( 3 ) using screws and bolts ( 4 ).

***N.B.-:-TORQUE REQUIREMENTS : 22 N.M (16 LBS.FT)***

- Pre-operation test : Place a load of 176 kg (388 lbs) on the carrier and carry out an inspection.  Pre-operation inspection.

# E - General Specifications

## 5.2.7 - Specific decals

### Location of the decals

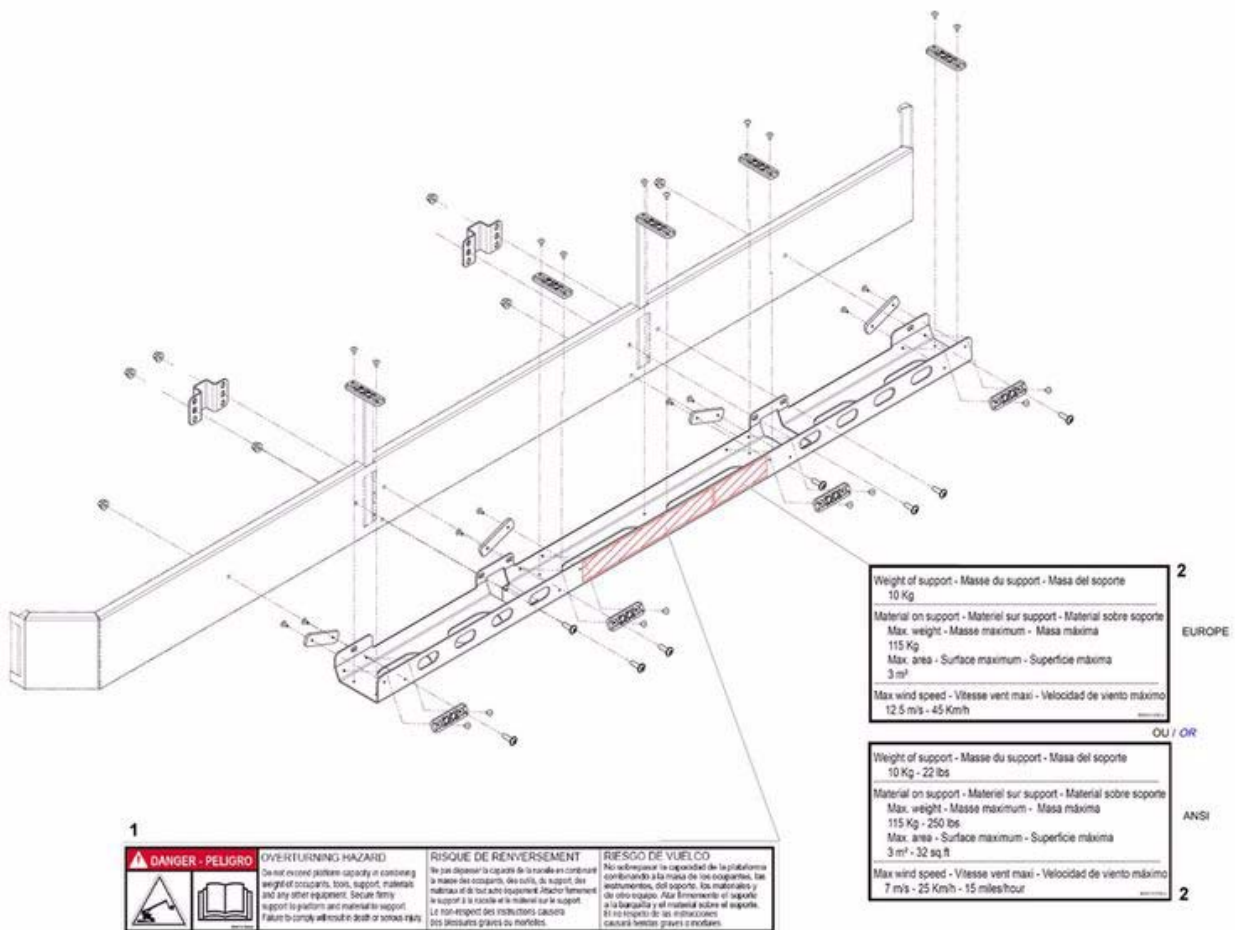

Marking	Description	Quantity	Part number
1	Risk of overturning	1	40000131830
2	Equipment characteristics	1	CE / AS : 4000131630 ANSI / CSA: 4000131730

# E - General Specifications

## 5.3 - ACTIV' SHIELD BAR - SECONDARY GUARDING SYSTEM

### 5.3.1 - Description

Activ' Shield Bar is a secondary guarding device.



It should be noted that this device doesn't release the operator from the responsibilities of learning and practicing the principles of safe machine operations provided by the manufacturer's instructions, employer's safety rules and worksite regulations.

### 5.3.2 - Characteristics

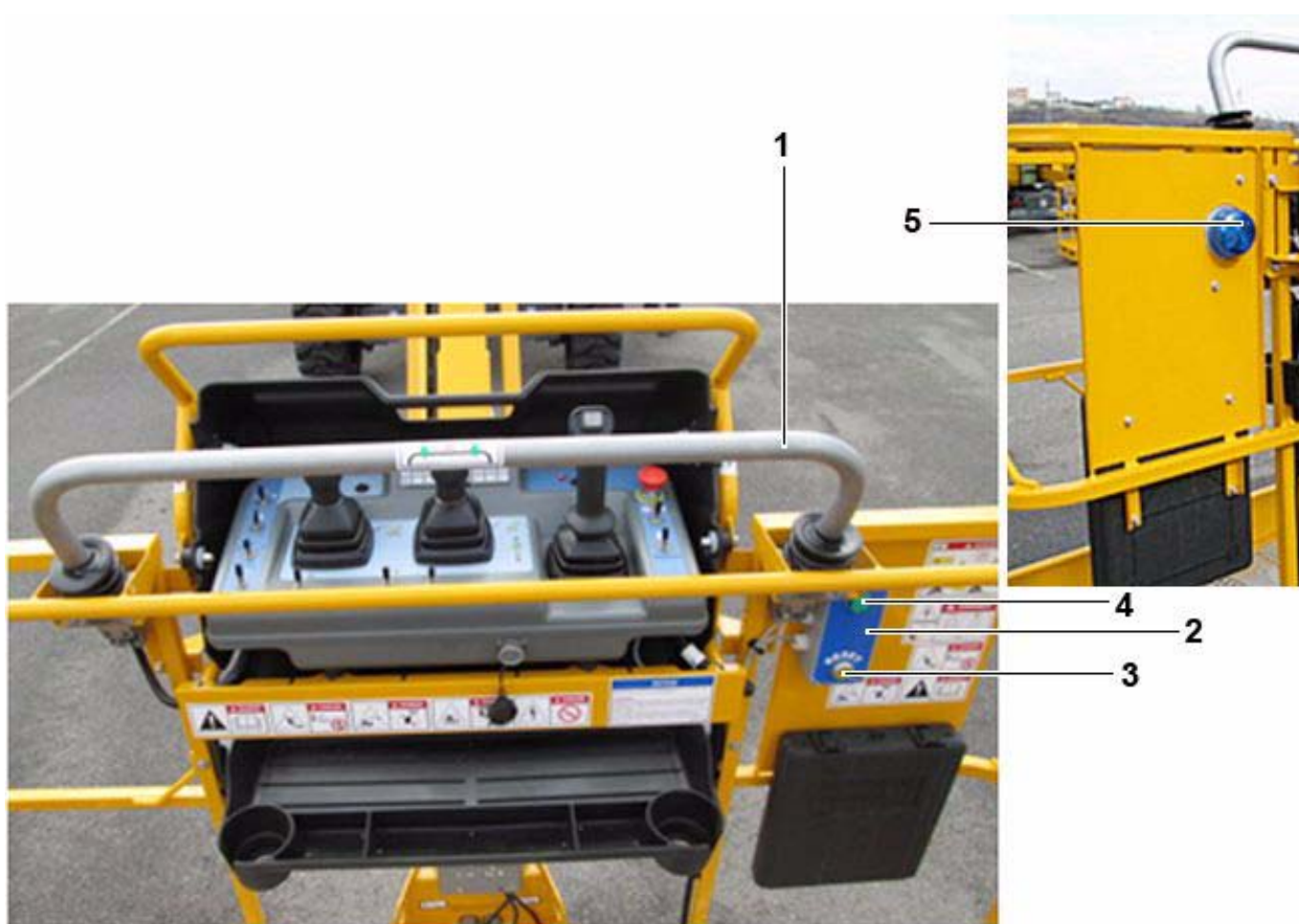

Marking	Description
1	Activation bar
2	Electrical box
3	RESET push-button
4	Green indicator, the system is switched on
5	Blue flashing indicator, indicates activation bar operates

# E - General Specifications

## 5.3.3 - Safety precautions

- Check the work area for overhead clearances, obstructions or other possible hazards.
- When driving, position the platform so as to provide the best visibility possible and avoid any blind spots.
- Always ensure that the chassis is never driven any closer than 1 m (3 ft3 in) from holes, bumps, tilts, obstructions, debris and ground coverings that may hide dangers.
- During operation, keep all the parts of the body inside the platform.
- To position the machine close to obstacles, it is recommended to use boom movements (arm, boom, etc.) instead of the drive movements.
- Do not drive fast in narrow or cluttered areas. Keep speed under control while making turns or sharp bends.
- Do not use the Activ' Shield Bar as a handhold. To prevent unintentional activation of the system.

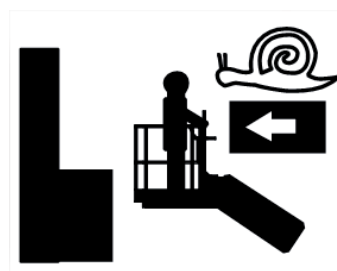
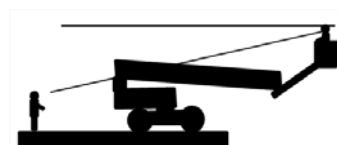

# E - General Specifications

## 5.3.4 - Pre-operation inspection



- If any item on the checklist is marked NO during the inspection; machine must be tagged and locked out and placed out of service.
- DO NOT operate the machine until all identified items are corrected and it has been declared safe for operation.

Description	Yes	No
<b>Perform all specified machine functional tests</b>		
<ul style="list-style-type: none"> <li>• All machine functional tests result positive</li> </ul>		
<b>Start the machine from platform control box</b>		
<b>Switch OFF all emergency push button</b>		
<ul style="list-style-type: none"> <li>• Check absence of warning signal</li> <li>• Check that the green indicator of the electrical box is switched on</li> </ul>		
<b>Performs the secondary guarding system tests for each movement specified in the table hereinbelow</b>		
<ul style="list-style-type: none"> <li>• Push the switch bar while operating the specified movement</li> <li>• Check what movement are authorized and complete the table</li> <li>• Check that visual and audible warning are activated</li> <li>• Check that the reset button of the electrical box is illuminated</li> <li>• Push the reset button</li> <li>• Check that normal operation is restored</li> </ul>		

A

B

C

D

E

F

G

H

I

# E - General Specifications

		Operated movement when the bar is triggered																	
		Driving						Rotation						Lifting or telescope extension			Other movement		
		Move forward			Move backwards			Left			Right								
			Ye s	N o		Ye s	N o		Ye s	N o		Ye s	N o		Ye s	N o		Ye s	N o
Platform control box	Forward drive	■			■			■			■			■			■		
	Reverse drive	■			■			■			■			■			■		
	Turntable left	■			■			■			■			■			■		
	Turntable right	■			■			■			■			■			■		
	Lifting or telescope extension	■			■			■			■			■			■		
	Boom descent and retraction telescope	■			■			■			■			■			■		
	Other movement	■			■			■			■			■			■		
Ground control box	All	■			■			■			■			■			■		

■	Authorized
■	Prohibited
■	Authorized if all switches / joysticks of the Platform control box are in neutral position or, if the Enable switch has been released

# E - General Specifications

## 5.3.5 - Operation

When the switch bar is triggered, the currently active function movement is stopped. Alarm and flashing light are activated. Only safeguard functional movements (lowering, retracting or reverse movement of the function that created the situation) are available from the platform control box.

Normal operation is restored when the "Reset" button on the right hand side of the basket is pressed in or until the power supply is switched off.

Visual and audible warnings will alert personal at ground if rescue is necessary.

To operate safeguard movement from platform control box :

- Joystick and/or switch must be reset to neutral position (function inactive).
- Enable switch must be activated.
- Operate safeguard movement using joystick or switch to move away from the hazard that triggered the device.
- Press the yellow Reset button to restore normal operation of the machine
- All movements can be operated from the ground control box even if the secondary guarding bar is triggered.

***N.B.-:-ANY MODIFICATION MADE TO THE FACTORY SETTINGS (E.G. INCREASING MOVEMENT SPEED AND/OR RAMPS ) VIA THE CONSOLE WILL INCREASE STOPPING DISTANCES AFTER SYSTEM ACTIVATION AND THEREBY REDUCES LEVEL OF SECURITY.***

# E - General Specifications

## 5.3.6 - Specific decals

Location of the decals

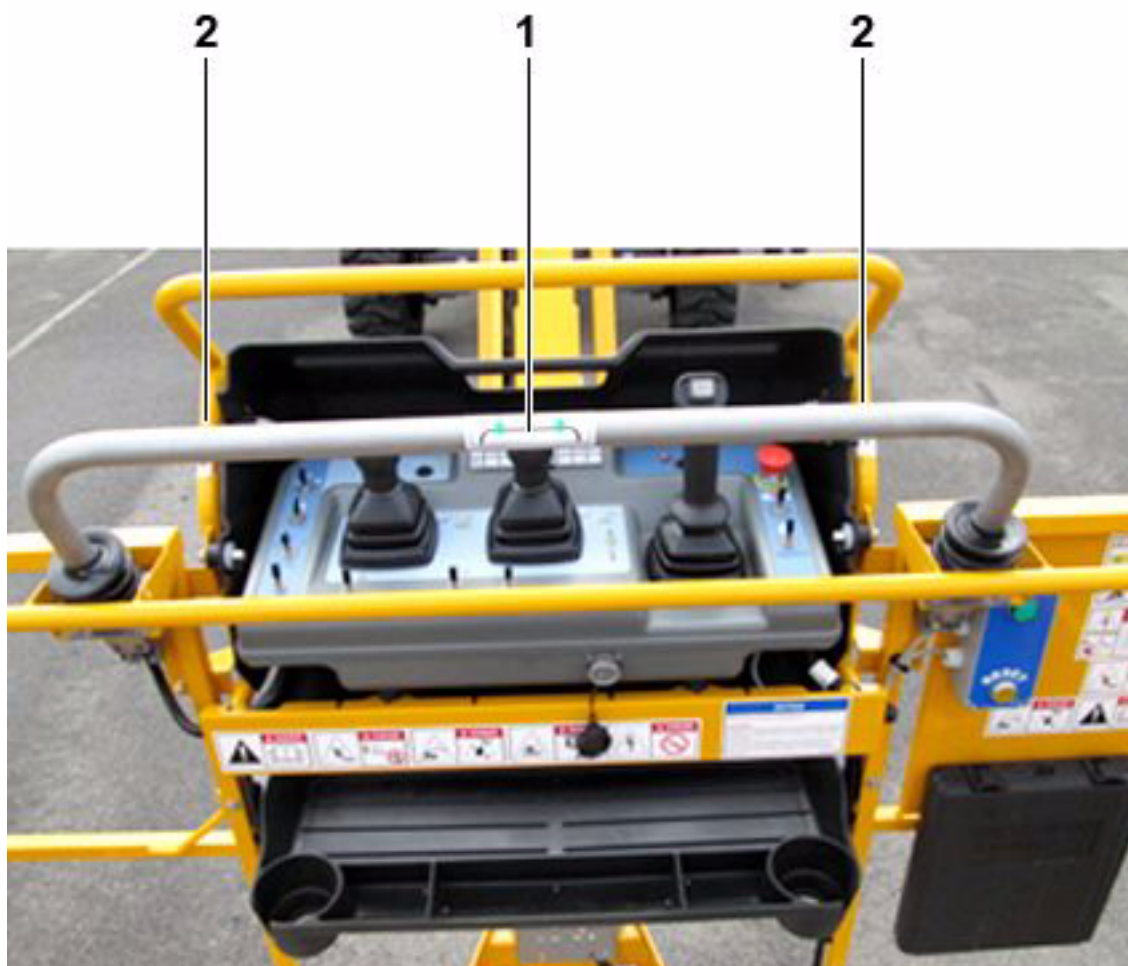

Marking	Description	Quantity	Part number
1	Do not lean on the bar	1	4000206690
2	Hand crushing hazard	2	4000244570

# E - General Specifications

## 5.4 - SWING GATE

### 5.4.1 - Description

"SWING GATE" consists of a laterally mounted pivoting  $\frac{1}{2}$  gate with closing latch, which enables a better access in platform for the user. Swing Gate allows access to the platform. Spring loaded hinges and a latching mechanism allows the gate to swing inwards only.



### 5.4.2 - Characteristics

Width of the gate : 500 mm ( 19.68 in).

### 5.4.3 - Safety precautions

- The gate is part of the guardrail system and must be securely fastened after entering the platform.
- Pay attention to the toe board when entering or exiting the platform.

### 5.4.4 - Pre-operation inspection

- Inspect that the latching mechanism is securely fastened.
- Check the hinges and latch operate correctly and are not deformed.
- Ensure that the gate returns automatically to the closed and fastened position after entering or exiting the platform.



# F - Maintenance

## 1 - General

As an owner and/or operator of Haulotte equipment, your Safety is of utmost importance to HAULOTTE®, which is why HAULOTTE® places such a high priority on product safety.

INSPECTIONS are not only required by HAULOTTE®, but may also be required by industry standards and/or governmental regulations.

To ensure that your equipment continues to perform to the factory set performance levels, it is important that you regularly maintain your equipment and avoid making any modifications that are not approved by HAULOTTE®. Regular and timely inspections will reduce equipment down time as well as prevent possible injury.

***N.B.-:DO NOT OPERATE UNLESS YOU ARE FAMILIAR AND TRAINED IN THE PRINCIPLES OF SAFE MACHINE OPERATION.***

### Overview :

- Walk-around inspections take only a few minutes at the beginning and end of each shift – one of the best ways to prevent mechanical problems and safety hazards.

### What to Do :

- Use your senses: sight, smell, hearing and touch.

### Frequency :

- Check your machine periodically during your entire workday.
- Make sure to do your inspection the same way every time.
- Complete one of these inspections at the start and end of each shift.

***N.B.-:IF DAMAGE OR UNAUTHORIZED MODIFICATIONS ARE DISCOVERED, THE MACHINE MUST BE REMOVED FROM SERVICE UNTIL REPAIRS ARE MADE BY A QUALIFIED SERVICE TECHNICIAN.***

It is the owner's responsibility to ensure the required maintenance as recommended by Haulotte is completed prior to the operation of the machine.

If regular maintenance is not carried out, this may :

- Void the warranty.
- Cause machine malfunction.
- Reduce machine reliability and shorten its service life.
- Jeopardize operator safety.

HAULOTTE Services® technicians are specially trained to carry out extensive repairs, interventions or adjustments on the safety systems or elements of HAULOTTE® machines. They carry genuine HAULOTTE spare parts and tools as required, and also provide fully documented reports on all work completed.

The inspection and maintenance table, identifies the role and the responsibilities of each party in periodical machine maintenance.  Section C 4 Inspection and Functional test.

# F - Maintenance

## 2 - Maintenance Schedule

This section provides the necessary information needed to place the machine in safe operation. For maximum service life and safe operation, ensure that all the necessary inspections and maintenance have been completed. There are a number of factors which can affect the design life including but not limited to, severity of operating conditions/routine maintenance which should be carried out in accordance with this manual.

Severity of operating conditions may require a reduction in time between maintenance periods. Machines that have been out of service for more than 3 months must undergo a periodic inspection before the machine is put back into service.

Maintenance must be carried out by a competent company or person familiar with mechanical procedures.

Maintenance operations performed must be recorded in a register / log book of the machine.

# F - Maintenance

## 3 - Inspection program

### 3.1 - GENERAL PROGRAM

The machine must be inspected on a regular basis at intervals of no less than once 1 per year. The purpose of the inspection is to detect any defect which could lead to an accident during routine use of the machine. Local standards and regulations may require more frequent inspections.

HAULOTTE® requires Reinforced and Major Inspections to be carried out on the product to extend its service life.

Inspections must be carried out by a competent company or person.

The inspection results must be recorded in the safety register or machine log book controlled and overseen by the company manager. This register or machine log book and the list of competent repair persons must be made available to the government work inspector and HAULOTTE Services®.

When	Responsible	Stakeholder	What
Before sale	Owner (or renter)	Competent technician or qualified technician HAULOTTE Services®	Periodic inspection
Before rent	Owner (or renter)	Competent technician or qualified technician HAULOTTE Services®	Daily inspection
Before use or every change of user	User	User	
Annually ( 1 year)	Owner (or renter)	Competent technician or qualified technician HAULOTTE Services®	Periodic inspection
5 years	Owner (or renter)	Qualified technician HAULOTTE Services®	Reinforced inspection
10 years	Owner (or renter)	Qualified technician HAULOTTE Services®	Major inspection

### 3.2 - DAILY INSPECTION

The Daily inspection includes a visual inspection, operational checks and testing of the safety systems. This must be conducted by the operator before using the machine.

This inspection is the responsibility of the user.

# F - Maintenance

## 3.3 - PERIODIC INSPECTION

The Periodic inspection is a thorough evaluation of the operation and safety features of the machine.

It must be conducted before the sale / resale of the machine and/or at least once every year.

Local regulations may have specific requirements on frequency, and content of inspections.

The severity of operating conditions may require frequent inspections.

This inspection is the responsibility of the owner, and inspections must be carried out by a competent company or person.

This inspection is in addition to the daily inspection.

This inspection should also be conducted after :

- Extensive dismantling and reassembly of major components.
- Repairs involving the machine's essential components.
- Any accident causing stress to the machine.

## 3.4 - REINFORCED INSPECTION

The Reinforced inspection is a thorough evaluation of the machine's structural components, to ensure proper functionality of the machine.

This evaluation must occur at a frequency of 5000 hours or every 5 years.

This inspection is the responsibility of the owner, and it must be conducted by a HAULOTTE Services® technician or by a competent company or person.

This inspection includes :

- Daily inspection
- Periodic inspection

***N.B.-:-REFER TO THE MAINTENANCE MANUAL FOR DETAILS.***

## 3.5 - MAJOR INSPECTION

The Major inspection is a thorough evaluation of the machine's integrity and proper functioning; after a standard/normal working life of 10 years.

This evaluation must take place after 10 years of operation and then repeated every 5 years thereafter.

The severity of operating conditions may require frequent inspections.

This inspection is the responsibility of the owner, and it must be conducted by a HAULOTTE Services® technician.

This inspection includes :

- Daily inspection
- Periodic inspection
- Reinforced inspection

***N.B.-:-REFER TO THE MAINTENANCE MANUAL FOR DETAILS.***

# F - Maintenance

## 4 - Repairs and adjustments

Extensive repairs, interventions or adjustments on the safety systems or components must be performed by a HAULOTTE Services® technician. Use original spare parts and components only.

***N.B.-:HAULOTTE SERVICES® TECHNICIANS ARE TRAINED PROFESSIONALS TO PERFORM EXTENSIVE REPAIRS, INTERVENTIONS AND ADJUSTMENTS ON THE SAFETY SYSTEMS OR COMPONENTS OF HAULOTTE® MACHINES. THE TECHNICIAN CARRIES GENUINE HAULOTTE® SPARE PARTS AND TOOLS AS REQUIRED, AND ALSO PROVIDES FULLY DOCUMENTED REPORTS ON ALL WORK COMPLETED.***

HAULOTTE Services® will not take responsibility for any outcomes resulting from inferior services or repairs performed by other unauthorised personnel.

HAULOTTE® reminds that NO modifications SHALL be carried out without the written permission of HAULOTTE®.

Any unauthorised repairs/modifications will void HAULOTTE® warranty.

With the utmost care to ensure enhanced reliability and greater safety of the HAULOTTE® products, it is pertinent that when a "Service or Safety Bulletin" is issued, action is taken immediately. Once the bulletin has been addressed, make sure that the completed form is submitted to HAULOTTE®.

***N.B.-:WHEN DISPOSING OR SCRAPPING THIS MACHINE, PLEASE CONSIDER APPROPRIATE METHODS OF RECYCLING. ANY ITEMS THAT REQUIRE SPECIFIC DISPOSAL ARE LISTED WITH INSTRUCTIONS IN THE MAINTENANCE MANUAL.***



# G - Other information

## 1 - Warranty disclosure

### 1.1 - AFTER SALES SERVICE

Our HAULOTTE Services® After Sales Service is at your disposal throughout your machine's service life to ensure the optimum use of your HAULOTTE product :

- When contacting our After Sales Service, ensure that you provide the machine model and serial number.
- When ordering any consumables or spare parts, please use this manual and the HAULOTTE® Essential catalogue to receive your genuine HAULOTTE® spare parts, your only guarantee of parts interchangeability and correct machine operation.
- If there is an equipment malfunction involving a HAULOTTE® product, then contact HAULOTTE Services® immediately even if the malfunction does not involve material and/or bodily damage.

### 1.2 - MANUFACTURER'S WARRANTY

#### 1.2.1 - Warranty acceptance

On reception of his machine, the owner or rental company must check the machine's condition and fill out the machine reception slip provided.

#### 1.2.2 - Warranty period

The present warranty is valid for a period of 12 months or up to a maximum of 1000 operating hours for lifting and handling equipment and 2000 operating hours for public works machinery, starting from delivery and terminating when the first limit is reached.

Spare parts are covered by a 6 month warranty.

#### 1.2.3 - Procedure conditions

To benefit from the warranty, the owner or rental company must inform the nearest HAULOTTE® subsidiary or the subsidiary that delivered the machine (the only dealer authorised to carry out an intervention under the manufacturer's warranty agreement) of the defect in writing as quickly as possible.

The subsidiary will decide whether to repair or replace the part that proves to be faulty.

The owner or rental company must present the duly completed maintenance book supplied with the machine as proof that the maintenance operations recommended by the manufacturer have been carried out.

The owner or rental company must ensure that the defect covered by the HAULOTTE® warranty is reported to and acknowledged by the HAULOTTE® subsidiary as rapidly as possible or must report the defect in writing.

Work carried out under the HAULOTTE® warranty will be performed by the subsidiary which delivered the machine, wherever possible.

# G - Other information

## 1.2.4 - Conditions of warranty

HAULOTTE® guarantees its products against defects, faults or manufacturing defects when the owner or rental company has informed HAULOTTE® of the defect.

The warranty does not cover the consequences of normal wear, nor any defects, failure or damage resulting from poor maintenance or abnormal usage, in particular overloading, impact by an external source, faulty installation or any modification made to products marketed by HAULOTTE® and performed by the owner or rental company.

In the event of operation or use which does not comply with the instructions or recommendations in the maintenance book, warranty claims will not be accepted.

The machine utilisation period must be recorded by reading the engine hour meter whenever an intervention is made. The engine hour meter must be maintained in good working order to guarantee maximum working life and to justify maintenance at the recommended time.

Warranty obligations for the time period stated above will cease immediately in situations where the defect is due to the following reasons :

- Use of spare parts that are not HAULOTTE® originals.
- If elements or products other than those recommended by the manufacturer are used.
- If the HAULOTTE® name, serial numbers or identification marks are removed or altered.
- After an unreasonably long delay before reporting a manufacturing problem.
- If the owner or rental company continues to use the machine despite problems.
- If damage is caused by modifications that do not comply with HAULOTTE® specifications.
- If lubricants, hydraulic oils or fuels that do not comply with HAULOTTE® recommendations are used.
- If the machine is incorrectly repaired or used by the customer.
- In case of an accident caused by a third party.

If no particular agreement has been made, any claims made after the previously established warranty period has expired will be refused.

The present warranty does not cover damage that may result directly or indirectly from any flaws or defects covered by the latter :

- Consumables : No claims will be accepted for objects or parts replaced in the context of normal machine usage.
- Settings : Adjustments of all sorts may become necessary at any time. Therefore adjustments are considered a part of normal machine usage conditions and are not covered by the warranty.
- Hydraulic and fuel circuit contamination : Every possible precaution is taken to ensure that fuel and hydraulic liquid delivered is clean. HAULOTTE® will not accept any claims concerning cleaning of the fuel circuit, filter, injection pump or any other equipment in direct contact with fuel or lubricants.
- Wearing parts (pads, bearings, tires/tyres, connections, etc.) : These parts are, by definition, subject to deterioration during the period of operation. Wearing parts will therefore not be covered by the warranty agreement.

# G - Other information

## 2 - Subsidiary contact information

	<p>HAULOTTE FRANCE PARC DES LUMIERES 601 RUE NICEPHORE NIEPCE 69800 SAINT-PIRIEST <b>TECHNICAL Department:</b> <b>+33 (0)820 200 089</b> <b>SPARE PARTS : +33 (0)820 205 344</b> FAX : +33 (0)4 72 88 01 43 E-mail : <a href="mailto:haulottefrance@haulotte.com">haulottefrance@haulotte.com</a> <a href="http://www.haulotte.fr">www.haulotte.fr</a></p>		<p>HAULOTTE ITALIA VIA LOMBARDA 15 20098 SAN GIULIANO MILANESE (MI) <b>TEL: +39 02 98 97 01</b> FAX: +39 02 9897 01 25 E-mail : <a href="mailto:haulotteitalia@haulotte.com">haulotteitalia@haulotte.com</a> <a href="http://www.haulotte.it">www.haulotte.it</a></p>		<p>HAULOTTE INDIA Unit No. 1205, 12th floor, Bhumiraj Costarica, Plot No. 1&amp;2, Sector 18, Palm Beach Road, Sanpada, Navi Mumbai- 400 705 Maharashtra, INDIA Tel. : +91 22 66739531 to 35 E-mail : <a href="mailto:sray@haulotte.com">sray@haulotte.com</a> <a href="http://www.haulotte.in">www.haulotte.in</a></p>
	<p>HAULOTTE HUBARBEITSBÜHNEN GmbH AN DER MÖHLINHALLE 1 D-79189 BAD KROZINGEN-HAUSEN <b>TEL : +49 (0) 7633 806 92-0</b> FAX : +49 (0) 7633 806 92-18 E.mail : <a href="mailto:haulotte@de.haulotte.com">haulotte@de.haulotte.com</a> <a href="http://www.haulotte.de">www.haulotte.de</a></p>		<p>HAULOTTE VOSTOK 35, SVOBODY STREET Bldg. 19 125362 MOSCOW RUSSIA <b>TEL/FAX : +7 495 221 53 02 / 03</b> E.mail : <a href="mailto:info@haulottevostok.ru">info@haulottevostok.ru</a> <a href="http://www.haulotte-international.com">www.haulotte-international.com</a></p>		<p>HAULOTTE DO BRASIL AV. Tucunaré, 790 CEP: 06460-020 – TAMBORÉ BARUERI – SAO PAULO – BRASIL <b>TEL : +55 11 4196 4300</b> FAX : +55 11 4196 4316 E.mail : <a href="mailto:haulotte@haulotte.com.br">haulotte@haulotte.com.br</a> <a href="http://www.haulotte.com.br">www.haulotte.com.br</a></p>
	<p>HAULOTTE IBERICA C/ARGENTINA Nº 13 - P.I. LA GARENA 28806 ALCALA DE HENARES MADRID <b>TEL : +34 902 886 455</b> TEL SAT : +34 902 886 444 FAX : +34 911 341 844 E.mail : <a href="mailto:iberica@haulotte.com">iberica@haulotte.com</a> <a href="http://www.haulotte.es">www.haulotte.es</a></p>		<p>HAULOTTE POLSKA Sp. Z.o.o. UL. GRANICZNA 22 05-090 RASZYN - JANKI <b>TEL : +48 22 720 08 80</b> FAX : +48 22 720 35 06 E-mail : <a href="mailto:haulottepolska@haulotte.com">haulottepolska@haulotte.com</a> <a href="http://www.haulotte.pl">www.haulotte.pl</a></p>		<p>HAULOTTE MÉXICO, Sa de Cv Calle 9 Este, Lote 18, Cívica, Jiutepec, Morelos CP 62500 Cuernavaca México <b>TEL : +52 77 7321 7923</b> FAX : +52 77 7516 8234 E-mail : <a href="mailto:haulotte.mexico@haulotte.com">haulotte.mexico@haulotte.com</a> <a href="http://www.haulotte-international.com">www.haulotte-international.com</a></p>
	<p>HAULOTTE PORTUGAL ESTRADA NACIONAL NUM. 10 KM. 140 - LETRA K 2695 - 066 BOBADELA LRS <b>TEL : + 351 21 995 98 10</b> FAX : + 351 21 995 98 19 E.mail : <a href="mailto:haulotteportugal@haulotte.com">haulotteportugal@haulotte.com</a> <a href="http://www.haulotte.es">www.haulotte.es</a></p>		<p>HAULOTTE SINGAPORE Pte Ltd. No.26 CHANGI NORTH WAY, SINGAPORE 498812 <b>Parts and service Hotline:</b> <b>+65 6546 6150</b> FAX : +65 6536 3969 E-mail : <a href="mailto:haulotteasia@haulotte.com">haulotteasia@haulotte.com</a> <a href="http://www.haulotte.sg">www.haulotte.sg</a></p>		<p>HAULOTTE MIDDLE EAST FZE PO BOX 293881 Dubai Airport Free Zone DUBAI United Arab Emirates <b>TEL : +971 (0)4 299 77 35</b> FAX : +971 (0) 4 299 60 28 E-mail : <a href="mailto:haulottemiddle-east@haulotte.com">haulottemiddle-east@haulotte.com</a> <a href="http://www.haulotte-international.com">www.haulotte-international.com</a></p>
	<p>HAULOTTE SCANDINAVIA AB Täljegårdsgatan 12 431 53 Mölndal SWEDEN <b>TEL : +46 31 744 32 90</b> <b>FAX : +46 31 744 32 99</b> E-mail : <a href="mailto:info@se.haulotte.com">info@se.haulotte.com</a> <a href="mailto:sparers@se.haulotte.com">sparers@se.haulotte.com</a> <a href="http://www.haulotte.se">www.haulotte.se</a></p>		<p>HAULOTTE TRADING (SHANGHAI) Co. Ltd. #7 WORKSHOP No 191 HUA JIN ROAD MIN HANG DISTRICT SHANGHAI 201108 CHINA <b>TEL : +86 21 6442 6610</b> FAX : +86 21 6442 6619 E-mail : <a href="mailto:haulotteshanghai@haulotte.com">haulotteshanghai@haulotte.com</a> <a href="http://www.haulotte.cn">www.haulotte.cn</a></p>		<p>HAULOTTE ARGENTINA Ruta Panamericana Km. 34,300 (Ramal A Escobar) 1615 Gran Bourg (Provincia de Buenos Aires) Argentina <b>TEL.: +54 33 27 445991</b> FAX. +54 33 27 452191 E-mail : <a href="mailto:haulotteargentina@haulotte.com">haulotteargentina@haulotte.com</a> <a href="http://www.haulotte-international.com">www.haulotte-international.com</a></p>
	<p>HAULOTTE UK Ltd STAFFORD PARK 6 TELFORD - SHROPSHIRE TF3 3AT <b>TEL : +44 (0)1952 292753</b> FAX : + 44 (0)1952 292758 E.mail : <a href="mailto:salesuk@haulotte.com">salesuk@haulotte.com</a> <a href="http://www.haulotte.co.uk">www.haulotte.co.uk</a></p>		<p>HAULOTTE GROUP / BILJAX 125 TAYLOR PARKWAY ARCHBOLD, OH 43502 - USA <b>TEL : +1 419 445 8915</b> FAX : +1 419 445 0367 Toll free : +1 800 537 0540 E-mail : <a href="mailto:sales@us.haulotte.com">sales@us.haulotte.com</a> <a href="http://www.haulotte-usa.com">www.haulotte-usa.com</a></p>		<p>HAULOTTE GROUP 1301 E PATRICK STREET FREDERICK, MD 21701 - USA <b>TEL : +1 301 663 0852</b> FAX : +1 301 663 0572 Toll free : +1 800 537 0540 E.mail : <a href="mailto:sales@us.haulotte.com">sales@us.haulotte.com</a> <a href="http://www.haulotte-usa.com">www.haulotte-usa.com</a></p>
	<p>HAULOTTE NETHERLANDS BV Koopvaardijweg 26 4906 CV OOSTERHOUT - Nederland <b>TEL : +31 (0) 162 670 707</b> FAX : +31 (0) 162 670 710 E.mail <a href="mailto:info@haulotte.nl">info@haulotte.nl</a></p>		<p>HAULOTTE AUSTRALIA PTY Ltd 46 GREENS ROAD DANDENONG - VIC - 3175 <b>TEL : 1 300 207 683</b> FAX : +61 (0)3 9792 1011 E.mail : <a href="mailto:sales@haulotte.com.au">sales@haulotte.com.au</a></p>		<p>HAULOTTE CHILE El Arroyo 840 Lampa (9380000) Santiago (RM) <b>TEL : + 562 2 3727630</b> E.mail : <a href="mailto:haulotte-chile@haulotte.com">haulotte-chile@haulotte.com</a> <a href="http://www.haulotte-chile.com">www.haulotte-chile.com</a></p>

# G - Other information

For the engine powered machines destined to the US market (Standards ANSI and CSA)

## CALIFORNIA

### Proposition 65 Warning

Diesel engine exhaust and some of its constituents are known to the state of California to cause cancer, birth defects, and other reproductive harm