

SPECIFICATIONS

Size	Metric	British
Max. Working Height	28.6m	93ft 10in
Max. Platform Height	26.6m	87ft 3in
Max. Operating Range(+0.6m)	21.9m	71ft 10in
Max. Platform Range	21.3m	69ft 11in
Overall Length(Stowed) A	11.66m	38ft 3in
Overall Length(Transport)	11.82m	38ft 9in
Overall Width(Stowed) B	2.5m	8ft 2in
Overall Width(Transport)	2.28m	7ft 6in
Overall Height(Stowed) C	2.87m	9ft 5in
Overall Height(Transport)	2.59m	8ft 6in
Platform Size(Length×Width)	2.44m×0.91m	8ft×3ft
Turntable Tailswing	1.61m	5ft 3in
Ground Clearance D	0.41m	1ft 4in
Wheelbase E	2.8m	9ft 2in
Turning Radius(Inside/Outside)	1.87m/3.22m	6ft 2in/10ft 7in
Tyres	385/45-28	385/45-28

Performance		
S.W.L	454kg	1000lb
Max. Occupants	3	3
Gradeability	45%	45%
Travel Speed(Stowed)	6km/h	6km/h
Travel Speed(Raised)	1.1km/h	1.1km/h
Max. Working Slope	X-5°/Y-5°	X-5°/Y-5°
Turret Rotation	360°Continuous	360°Continuous
Platform Rotation	180°	180°
Jib Movement	135°	135°

Weight		
Overall Weight	18400kg	40565lb

Power		
Diesel Engine	Deutz TD2.9 L4	Deutz TD2.9 L4
Engine Power	55.4kW 2600rpm	55.4kW 2600rpm
Diesel Tank	135L	29gal
Hydraulic Tank	165L	36gal

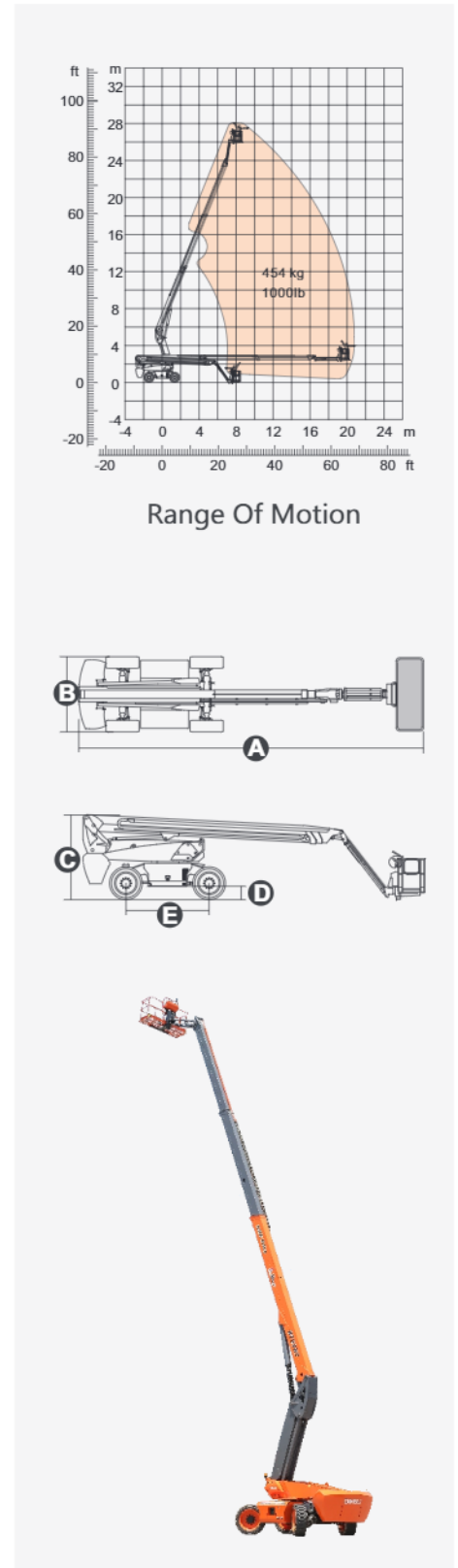

FEATURES

Standard Items

- 2.31m (7ft 7in) Jib Boom
- Front Oscillating Axle
- Four-Wheel Steering
- Four-Wheel Drive
- Self-Leveling Platform
- 180° Left And Right Swing Platform
- Proportional Joystick Controls
- Thumb Rocker Steer
- Drive Enable
- Ac Power Cord To Platform
- Tilt Alarm
- Descent Alarm
- Flash
- Horn
- Hour Meter
- Integral Integrated Special Drive Axle For Construction Machinery
- 360° Continuous Turntable Rotation
- Positive Traction Four Wheel Drive
- Platform Load Sense System
- Fault Diagnosis System
- Operator Anti-crushing Protection System
- Harsh Environment Kits (includes Cylinder Sleeves, Boom Dust Kits, Ground And Platform Control Box Covers)
- 12V DC Auxiliary Power
- Deutz TD2.9 L4 55.4kW /2600rpm Diesel Engine *
- Hydraulic Oil Radiator
- Anti-restart Engine Protection
- Anti-reverse Engine Device
- Auto Engine Fault Shutdown

ZHEJIANG DINGLI MACHINERY CO., LTD.

Address: No.188 Qihang Road,Deqing,Zhejiang P.R.China 313219

Telephone: +86(572)8681688

E-Mail: export@cndingli.com

[Https://en.cndingli.com](https://en.cndingli.com)



