

For online reference and to download the manuals for your machines , go to:-

<https://www.e-technical-information.com>

or, scan the QR Code below

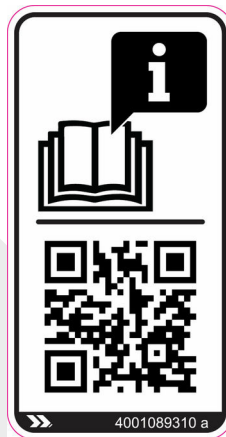

OPERATOR'S MANUAL

**COMPACT 8N AE - COMPACT 2032E AE - COMPACT 10N AE
- COMPACT 2632E AE - COMPACT 10 AE - COMPACT 2647E
AE - COMPACT 12 AE - COMPACT 3247E AE - COMPACT 14
AE - COMPACT 3947E AE**

Access control keypad

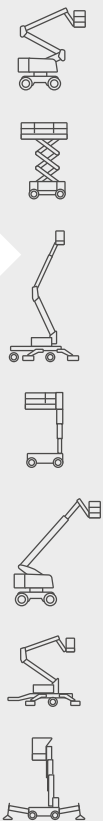

A - Foreword

1	Foreword.....	3
2	User responsibility.....	4
2.1	Owner's responsibility.....	4
2.2	Employer's responsibility.....	4
2.3	Trainer's responsibility.....	4
2.4	Operator's responsibility.....	4
3	Safety.....	5
3.1	Safety instructions.....	5
3.1.1	Incorrect use.....	5
3.1.2	Falling Hazards.....	5
3.1.3	Overturning / Tip-over Hazards.....	6
3.1.4	Risk of electric shock (electrocution).....	7
3.1.5	Explosion / Fire Hazards.....	8
3.1.6	Crushing / Collision Hazards.....	9
3.1.7	Risk of involuntary movements.....	9
4	Safety inquiries.....	10
5	Incident notification.....	11
6	Compliance.....	12
6.1	Product modification.....	12
6.1.1	Implementing manufacturer safety campaigns.....	12
6.2	Product specifications.....	12
6.3	Change of Ownership Notification.....	12

B - Familiarization

1	General safety.....	3
1.1	Intended use.....	3
1.2	Decal content.....	3
1.3	Level of severity.....	4
1.4	Symbols legend and definitions.....	5
1.5	Symbols and colors.....	7
2	Primary machine components.....	8
2.1	Layout.....	8
2.2	Maintenance support.....	10
2.3	Extension deck.....	11
2.4	Ground control box.....	12
2.4.1	Layout.....	12
2.4.2	Access control keypad.....	13
2.4.2.1	Indicators.....	14
2.4.3	HAULOTTE Activ'Screen.....	15
2.4.3.1	LCD screen.....	16
2.5	Platform control box.....	20
2.5.1	Layout.....	20
3	Performance Specifications.....	22
3.1	Technical characteristics.....	22
3.2	Working area / Range of motion.....	30
4	Decals and markings locations.....	35

C - Pre-operation inspection

1	Recommendations.....	3
2	Working area assessment.....	4
3	Inspection and Functional test.....	5
3.1	Daily inspection.....	5
4	Safety functional checks.....	8
4.1	Lowering for repairs.....	8
4.2	Emergency push buttons	9
4.2.1	Ground control box.....	9
4.2.2	Platform control box.....	9
4.3	Activation of controls.....	9
4.3.1	Ground control box.....	9
4.3.2	Platform control box.....	10
4.3.3	Foot Switch.....	10
4.4	Buzzers test.....	10
4.5	Indicator light test.....	11
4.6	Travel speed limitation.....	11
4.7	Slope warning device.....	12
4.8	Machine braking.....	12
4.9	Pothole protection system (Pothole protection)	13
4.10	Anti-crush system when lowering.....	14

D - Operation instructions

1	Operation.....	3
1.1	Introduction.....	3
1.2	Operation from the ground control box.....	3
1.3	Operation from the platform control box.....	4
2	Ground control box.....	5
2.1	To start and stop the machine.....	5
2.2	Movement control.....	5
2.3	Additional controls from the ground control box.....	5
3	Platform control box.....	6
3.1	To start and stop the machine.....	6
3.2	Drive and steer control.....	6
3.3	Elevation controls.....	6
3.4	Additional controls.....	7
4	Rescue and emergency procedures.....	8
4.1	In case of power loss.....	8
4.2	To rescue operator in platform.....	8
5	Transportation.....	9
5.1	Transport configuration.....	9
5.2	Folding guardrails.....	9
5.2.1	Description.....	9
5.2.2	Safety precautions.....	9
5.2.3	Guardrail folding procedure.....	10
5.2.4	Specific decals	14
5.2.5	Raising guardrails to working position.....	15
5.3	Machine stowage for transport.....	15
5.4	Unloading.....	16
5.5	Towing or winching (Slope crossing aid)	17

Contents

5.5.1	Electric brake release.....	17
5.6	Storage.....	18
5.7	Loading by ramp.....	18
5.8	Unloading by ramp.....	19
5.9	Lifting operation.....	19
5.9.1	Procedure for the use of slings COMPACT 8N AE (COMPACT 2032E AE) - COMPACT 10N AE (COMPACT 2632E AE).....	20
5.9.2	Procedure for the use of slings COMPACT 10 AE (COMPACT 2647E AE) - COMPACT 12 AE (COMPACT 3247E AE) - COMPACT 14 AE (COMPACT 3947E AE).....	23
5.10	Loading and unloading with forklift.....	26
6	Cold Weather Recommendations.....	27
6.1	Hydraulic oil.....	27
7	Battery care and maintenance.....	28
7.1	Battery recharge.....	28
7.1.1	On-board charger.....	28
7.1.2	Battery charging.....	29
7.1.3	Fault codes.....	31
7.2	Battery care and maintenance.....	31
7.2.1	Manual centralized battery filling (Optional)	32
7.2.2	Automatic battery filling (Optional)	34
7.2.3	Desulfation charge.....	34
7.3	Optimise battery life.....	35

E - General Specifications

1	Machine dimensions.....	3
2	Masses of the main sub-assemblies.....	6
3	Acoustics and vibrations.....	8
4	Wheel/Tire assembly.....	9
4.1	Technical specifications.....	9
4.2	Inspection and maintenance.....	9
4.2.1	Procedure of replacement.....	10
5	Options.....	11
5.1	Swing gate.....	11
5.1.1	Description.....	11
5.1.2	Characteristics.....	11
5.1.3	Safety precautions.....	11
5.1.4	Pre-operation instructions.....	11
5.1.5	Specific decals, optional.....	12
5.2	Pipe holder option.....	12
5.2.1	Description.....	12
5.2.2	Characteristics.....	12
5.2.3	Safety precautions.....	12
5.2.4	Pre-operation inspection.....	13
5.2.5	Operation.....	13
5.2.6	Disassembly - Assembly.....	14
5.2.7	Specific decals	15
5.3	Panel carrier.....	15
5.3.1	Description.....	15
5.3.2	Characteristics.....	16
5.3.3	Safety precautions.....	16
5.3.4	Pre-operation inspection.....	16

Contents

5.3.5	Operation.....	16
5.3.6	Disassembly - Assembly.....	17
5.3.7	Specific decals	19
5.4	SGS - SECONDARY GUARDING SYSTEM	19
5.4.1	Foreword.....	19
5.4.2	Safety precautions.....	19
5.4.3	Familiarization.....	20
5.4.4	How the system works.....	21
5.4.5	Inspecting the system before using the machine.....	23
5.4.6	Operating and using the SGS.....	24
5.4.7	Evacuation procedure if the operator is crushed or loses consciousness.....	24

F - Maintenance

1	General.....	3
2	Maintenance Schedule.....	4
3	Inspection program.....	5
3.1	General program.....	5
3.2	Daily inspection.....	5
3.3	Periodic inspection.....	5
3.4	Reinforced inspection.....	5
3.5	Major inspection.....	6
4	Repairs and adjustments.....	7

G - Other information

1	Conditions of warranty.....	3
2	Subsidiary contact information.....	4
2.1	California warning.....	5

H - Records

1	Intervention register.....	3
---	----------------------------	---

A - Foreword

1	Foreword.....	3
2	User responsibility.....	4
2.1	Owner's responsibility.....	4
2.2	Employer's responsibility.....	4
2.3	Trainer's responsibility.....	4
2.4	Operator's responsibility.....	4
3	Safety.....	5
3.1	Safety instructions.....	5
3.1.1	Incorrect use.....	5
3.1.2	Falling Hazards.....	5
3.1.3	Overturning / Tip-over Hazards.....	6
3.1.4	Risk of electric shock (electrocution).....	7
3.1.5	Explosion / Fire Hazards.....	8
3.1.6	Crushing / Collision Hazards.....	9
3.1.7	Risk of involuntary movements.....	9
4	Safety inquiries.....	10
5	Incident notification.....	11
6	Compliance.....	12
6.1	Product modification.....	12
6.1.1	Implementing manufacturer safety campaigns.....	12
6.2	Product specifications.....	12
6.3	Change of Ownership Notification.....	12

1 Foreword

You have just purchased a HAULOTTE® product and we would like to thank you for your business.

The aerial work platform is a device for lifting people designed and manufactured with the intent to enable users to access overhead elevated temporary workplaces with the necessary tools and equipment. All other uses or alterations/modifications to the aerial work platform must be approved by HAULOTTE®.

This manual shall be considered a permanent component of the machine and shall be kept with the aerial work platform in the designated Manual Holder, at all times.

Safe operation of this product can only be assured if you follow the operating instructions contained in this manual. To ensure the safe and appropriate use of this equipment, only trained personnel are authorised to use and carry out maintenance on the aerial work platform.

We would particularly like to draw your attention to 2 essential points :

- Comply with safety instructions.
- use this equipment within the performance limits specified by this user manual.

With regard to the designation of our equipment, we stress that this is purely for commercial purposes and not to be confused with the technical specifications. Only the specifications in this manual should be used to study the suitability of the equipment for the intended use.

This operator's manual is specific to the HAULOTTE® products listed on the cover page of this manual.



Original language and version : Manuals in English and French are the original instructions.
Manuals in other languages are translations of the original instructions.

The user manual does not replace the necessary training that is required for all of this machine's operators. HAULOTTE® has compiled this manual to assist in safe and efficient operation of the products covered in the manual.

The manual must be available to all operators and must be kept in a legible condition. Additional copies can be ordered from HAULOTTE Services®.

Stay Safe and keep working with HAULOTTE®!

For online reference and to download the manuals for your machines HAULOTTE®, go to :

<https://www.e-technical-information.com>

or, scan the QR Code below :

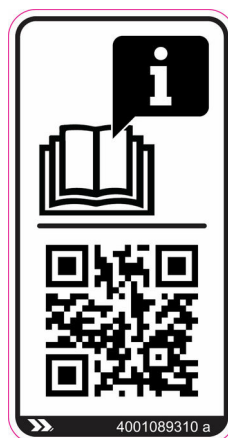

2 User responsibility

2.1 Owner's responsibility

The owner (or hirer) has the obligation to :

- To inform operators of the instructions contained in the Operator's Manual.
- Follow local regulations regarding operation of the machine.
- Replace all manuals or labels that are missing or in poor condition. Additional copies can be ordered from HAULOTTE Services®.
- To establish a preventive maintenance program in accordance with the manufacturer's recommendations, taking into account the environment and severity of use of the machine.
- To perform periodic inspections in accordance with HAULOTTE® recommendations and local regulations.

All malfunctions and problems identified during the inspection shall be corrected before the aerial work platform is returned to service.

2.2 Employer's responsibility

The employer (or plant superintendent) is required :

- To train and check the training of users.
- To authorise the trained user(s) to use the machine.
- To inform and familiarize the operator with the local regulations.
- Forbid anyone from operating the machine if :
 - Under the influence of drugs, alcohol, etc.
 - Subject to fits, convulsions, dizziness, etc.

2.3 Trainer's responsibility

- The trainer must be qualified to provide training to operators in accordance with applicable local regulations.
- The training must include all of the instructions in this manual.
- The training must be given in an obstacle-free area until the trainee is considered competent as defined by the training program undertaken.

2.4 Operator's responsibility

The operator has the obligation to :

- Read and understand the contents of this manual and familiarize himself/herself with the decals affixed on the machine.
- To inspect the machine before use according to HAULOTTE®'s recommendations..
- Inform the owner (or hirer) if the manual or any decals are missing or are not legible.
- Inform the owner (or hirer) of any machine malfunction.

Operators must ensure that the inspections have been carried out by the owner and that they can use the machine for the purpose intended by the manufacturer.



All users (driver, passenger, maintainer, transporter, etc.) must familiarise themselves with the emergency controls and machine operation in case of an emergency.

The operator has the obligation to stop using the machine in the event of malfunction or safety problems on the machine or in the work area and report the problem immediately to his/her supervisor.

3 Safety

3.1 Safety instructions

3.1.1 Incorrect use

- Do not use the machine outside of the conditions specified in this manual.
- Do not use the machine as a crane, material lift or elevator.



- Do not use the work platform as a hoisting machine (crane) by suspending a load outside of the platform.
- Do not tie the platform to an adjacent fixed or mobile structure.
- Do not use/operate the machine when alone. A survey person or immediate Supervisor must be present on the ground in case of emergency.
- Do not use a faulty or poorly maintained machine. Remove defective/damaged machine from service.
- Do not climb onto the compartment covers of the machine.
- Do not replace items critical to machine stability with items of different weight or specification.
- Do not replace the wheels installed in the factory with wheels with different characteristics.
- Do not alter or disable machine components that in any way affect safety and stability.
- Do not disable the safety devices.
- Do not use the machine if a label is missing or illegible.
- Do not damage, modify or hide machine labels or inscriptions.

3.1.2 Falling Hazards

N.B.-:THE GUARDRAIL IS THE MAIN PROTECTION SYSTEM AGAINST FALLS FROM THE MOBILE LIFTING PLATFORM (PEMP) .

Before commencing operation :

- Ensure that guard rails are correctly installed and secured.
- Ensure that gate or sliding bar is in its securely locked position.
- If using a machine that has a swing gate, check that the entry gate closes by itself and gate latches and locks.



- Remove oil or grease from the steps, floor, handrail and the guardrails.
- Clean the floor of the platform (no debris).

To enter or exit from the platform :

- The machine must be completely stowed (Access configuration) .
- Face the machine to access the opening to the platform.
- Keep 3 points of contact (both hands and a foot) on the steps and the guardrail.
- Keep fingers away from moving parts near entry gate.



A - Foreword

When in the platform :

- Where personal fall protection equipment (FPE) is required by the employer, a competent authority or local regulations, we recommend using a full harness with a safety line.
- Personal fall protection equipment must only be fastened to approved fall protection anchoring points on the platform provided for this purpose.
- Refer to this decal located on the platform.
- Safety lines must never be attached to an object or structure outside of the work platform.
- Hold on securely to the guardrails.
- Always keep your feet firmly on the floor of the platform.
- Do not sit, stand, or climb on the platform guard rails.
- Do not lean on the gate or sliding bar.
- Do not lean over the guard rails or climb over them. Only work in the platform area within the guard rails.
- Do not exit the platform until it is in the completely stowed position.
- Do not use the guardrail as a means of access to climb in or out of the platform.



3.1.3 Overturning / Tip-over Hazards

Before positioning and operating the machine :

- Ensure that the surface is capable of supporting the machine weight including the rated capacity.
- Do not exceed the maximum rated capacity that includes the weight of both material and allowed number of occupants. Do not exceed the allowable number of occupants.
- Do not increase the working height (using extensions, ladder, etc.).
- Do not place ladders or scaffolds in the platform or against any part of this machine.
- Position loads uniformly in the centre of the work platform.
- Do not use the machine at wind speeds that are above the permissible threshold. Refer to the display on the work platform to view the permissible wind speed.
- Do not increase the surface area of the platform exposed to wind. This includes adding panels, mesh, banners. Failure to follow this instruction may lead to a loss of stability and as a result, the machine could tip over.
- Do not raise the platform or move the machine with the platform raised on a slope with a gradient greater than the machine's permissible limit.
- Do not drive the machine on slopes or grades exceeding the specified limits.
- Do not pull or push towards any object outside of the platform. Do not exceed the maximum allowable side force stated in the performance specifications.
- Do not use the machine to support any external structure.
- Do not use the machine to tow other machines or to drag materials.



A - Foreword

- Using the machine on a slope :



Do not drive the machine on slopes with gradients exceeding the authorised transversal and lateral limits for the machine.  B 4.1 - Technical characteristics.

WIND: the aerial work platform can be used up to the maximum wind speed indicated in the specifications in this manual. To identify the local wind speed, use the Beaufort scale below, a wind gauge or an anemometer.

N.B.-:THE BEAUFORT SCALE OF WIND FORCE IS ACCEPTED INTERNATIONALLY AND IS USED WHEN COMMUNICATING WEATHER CONDITIONS. A WIND SPEED RANGE AT 10 M (32 FT 9 IN) ABOVE FLAT, CLEAR LAND IS ASSOCIATED WITH EACH DEGREE.

Beaufort scale

Force	Meteorological description	Observed effects	m/s	km/h	mph
0	Calm	Smoke rises vertically.	0 - 0,2	0 - 1	0 - 0,62
1	Very light breeze	Smoke indicates the wind direction.	0,3 - 1,5	1 - 5	0,62 - 3,11
2	Light breeze	Wind felt on the face. Leaves rustle. Weather vanes turn.	1,6 - 3,3	6 - 11	3,72 - 6,84
3	Slight breeze	Leaves and small twigs in constant motion. Flags move slightly.	3,4 - 5,4	12 - 19	7,46 - 11,8
4	Nice breeze	Raised dust and loose papers. Small branches are moved.	5,5 - 7,9	20 - 28	12,43 - 17,4
5	Nice breeze	Small trees in leaf to sway. Crested wavelets form on inland waterways.	8,0 - 10,7	29 - 38	18,02 - 23,6
6	Cool wind	Large branches in motion. Power lines and chimneys 'sing'. Umbrellas used with difficulty.	10,8 - 13,8	39 - 49	24,23 - 30,45
7	Near gale	Whole trees in motion. Inconvenience felt when walking against wind.	13,9 - 17,1	50 - 61	31 - 37,9
8	Gale	Some branches break. Generally we cannot walk against the wind.	17,2 - 20,7	62 - 74	38,53 - 45,98
9	Strong gale	The wind causes slight damage to buildings. Tiles and chimney stacks are blown off.	20,8 - 24,4	75 - 88	46,60 - 54,68

3.1.4 Risk of electric shock (electrocution)



Risk of death or serious injuries.

The machine is not electrically insulated and does not provide protection from contact or proximity to electrically charged conductors.

Always position all parts of the aerial work platform, the occupants, accessories and tools at a reasonable distance from power lines to ensure that no part of the work platform accidentally comes into contact with a power line.

A - Foreword

Apply local regulations pertaining to safety distances. If this is not possible, follow the distances in the table below at a minimum :

Minimum safe approach distances

Electric voltage	Minimum safety distance	
	Mètre	Feet
0 - 300 V	Avoid contact	
300 V - 50 kV	3	10
50 - 200 kV	5	15
200 - 350 kV	6	20
350 - 500 kV	8	25
500 - 750 kV	11	35
750 - 1000 kV	14	45

- Do not operate the machine when close to live power lines, consider the movement of the machine and the sway of the electric power lines particularly in windy conditions.
- Do not operate the machine during lightning, thunderstorms, snow/ice or any weather condition that could compromise operator safety.
- The machine must not be used while charging the batteries.
- When using the platform AC power supply, ensure it is protected with a circuit breaker and residual current device.
- Do not use the machine as a ground for welding.
- Do not weld on the machine without first disconnecting the battery terminals.
- Always disconnect ground cable first.



Keep away from the machine if it contacts energized power lines. Personnel on the ground or in the platform must not touch or operate the machine until energized power lines are shut off.



3.1.5 Explosion / Fire Hazards

Always wear protective clothing and eye wear when working with batteries and power sources/systems.

N.B. : Acid is neutralized with sodium bicarbonate and water.

- Do not work on or operate a machine in an explosive or flammable atmosphere / environment.
- Do not touch hot components.
- Do not bridge the battery terminals with metallic objects.
- Do not service the battery in proximity of spark, open flame, lit cigarettes.
- ALWAYS avoid contact with battery acid. Battery acid causes serious burns and should be kept away from skin or eyes. If contact occurs, flush with water and consult a physician immediately.



3.1.6 Crushing / Collision Hazards



Before using the machine, mark out the machine's work and circulation area using a marking system appropriate to the task at hand and the work environment.

When in the platform :

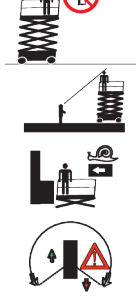
- Check the work area for overhead clearance, for any obstacles besides and below the platform when raising/lowering the platform and or before driving.
 - During movement, keep all the parts of the body inside the platform. Hold onto the guardrails on the opposite side to any surrounding structures. Take care to avoid trapping hands whilst holding the guardrails.
 - To position machine close to a building/structure, use extension deck feature, instead of driving machine closer to structure.
- 
- Warn personnel not to work, stand, or walk under a raised boom/platform.
 - Always ensure that the chassis is never kept any closer than 1 m (3 ft 3 in) to holes, bumps, slopes, obstructions, debris and ground coverings that may hide holes and other dangers.
 - Keep non-operating personnel at least 5 m (16 ft 5 in) away from the machine when driving.
 - Be aware of driving direction.
 - Check the driving direction with the help of the red or white arrows on the chassis and the platform control box.
 - Also note that when changing the driving direction (Forward <> Reverse) the joysticks or switches must return to the neutral position before reversing the drive direction and for movement to occur.
 - When driving, position the platform so as to provide the best possible visibility and to avoid any blind spots.
 - Hold on securely to the guardrails.
 - Personal Protection Equipment (EPI) :
 - The occupants of the aerial work platform must wear personal protection equipment and comply with local regulations in force.
 - Operators must comply with the safety standards of the job site and the employer, as well as the applicable state regulations relating to the use of personal protective equipment.
 - All personal fall protection equipment (PFPE) must comply with current regulations, must be inspected and used in accordance with the manufacturer's instructions.
 - Avoid contact with fixed or mobile obstacles (other machines).
 - Other machines (crane, aerial work platform, etc.) operating in the work area increase the risk of crushing or collision. Restrict the operation of machines moving within the aerial work platform work area.
 - Take into consideration the stopping distance, reduced visibility and blind spots of the machine.
 - Limit travel speed to suit the ground surface condition, slope (incline), and people in the vicinity.

3.1.7 Risk of involuntary movements

Never use a damaged or malfunctioning machine.

Always respect the following rules :

- Maintain clearance from high voltage lines.
- Maintain clearance from generators, radar, electromagnetic fields.
- Never expose the batteries or electrical components to water (high pressure washer, rain).

4 Safety inquiries

Inquiries relating to design criteria/specifications of a product, standards compliance, or overall machine safety should be sent to the HAULOTTE® PRODUCT SAFETY department.

Each inquiry or request should include all relevant information; including contact name, telephone number, mailing address, email address, plus the machine model and serial number.

The HAULOTTE® Product Safety department will evaluate each request/inquiry and will provide a written response.

5 Incident notification

Notify HAULOTTE® immediately when a HAULOTTE® product has been involved in an incident/accident leading to personal injury or death, or when there is a major property damage.

HAULOTTE Group - EUROPE Product Safety Department

Address : Rue Emile Zola - 42420 Lorette - France

Tel : +33 (0)4 77 29 24 24

Email : productsafety.europe@haulotte.com

HAULOTTE Group - Australia, India and Asia Product Safety Department

Address : No.26 Changi North Way - Singapore 498812 - Singapore

Tel : +65 6546 0123

Email : productysafety.apac@haulotte.com

HAULOTTE Group - North & South America Product Safety Department

Address : 3409 Chandler Creek Rd. - Virginia Beach, VA 23453 - United States

Tel : +1 757 689 2146

Email : productsafety.americas@haulotte.com

Connect to our website : www.haulotte.com



6 Compliance

6.1 Product modification

It is strictly forbidden to modify a HAULOTTE® product. Any modification may violate Haulotte design parameters, local regulations and industry standards.

Any requests for modification must be formulated in writing (form) and be approved by the manufacturer.

Do not hesitate to contact HAULOTTE Services®, should you have any questions relating to the issued bulletin(s) or with questions on the policy itself.

6.1.1 Implementing manufacturer safety campaigns

It is essential to implement the safety campaigns issued by the manufacturer. All of these campaigns are accessible on our website.

Connect to our website : www.haulotte.com



Never market (or sell) a machine without first having carried out all of the safety campaigns.

6.2 Product specifications

HAULOTTE® cannot be held liable for any changes to the technical characteristics/specifications contained in this manual. HAULOTTE® has a continuous improvement policy in place for its product range. Given this policy, the Company reserves the right to modify products technical characteristics / specifications without notice.

6.3 Change of Ownership Notification

It is important and necessary to keep HAULOTTE Services® updated with current ownership of the machine. This way, HAULOTTE® will be able to provide the necessary support for the product. If you have sold or transferred this machine(s); it is your responsibility to notify HAULOTTE Services®. It is not required to include Lessees/Renters of Leased/Rented machines on this form.

Connect to our website : www.haulotte.com



B - Familiarization

1	General safety.....	3
1.1	Intended use.....	3
1.2	Decal content.....	3
1.3	Level of severity.....	4
1.4	Symbols legend and definitions.....	5
1.5	Symbols and colors.....	7
2	Primary machine components.....	8
2.1	Layout.....	8
2.2	Maintenance support.....	10
2.3	Extension deck.....	11
2.4	Ground control box.....	12
2.4.1	Layout.....	12
2.4.2	Access control keypad.....	13
2.4.2.1	Indicators.....	14
2.4.3	HAULOTTE Activ'Screen.....	15
2.4.3.1	LCD screen.....	16
2.5	Platform control box.....	20
2.5.1	Layout.....	20
3	Performance Specifications.....	22
3.1	Technical characteristics.....	22
3.2	Working area / Range of motion.....	30
4	Decals and markings locations.....	35

B - Familiarization

1 General safety

1.1 Intended use

The HAULOTTE® (PEMP) lifting platforms are machines designed to move people, tools and equipment to work stations located at height.

N.B.-:USE THE MACHINE UNDER "NORMAL" CLIMATIC CONDITIONS. IF YOU NEED TO USE THE MACHINE IN CLIMATIC CONDITIONS LIKELY TO CAUSE DETERIORATION (EXTREME : HUMIDITY, TEMPERATURES, SALINITY, CORROSIVENESS, ATMOSPHERIC PRESSURE), CONTACT HAULOTTE SERVICES®. REDUCE INTERVALS BETWEEN SERVICING.

N.B.-:IN HARSH ENVIRONMENTS (HIGH LEVELS OF SALINITY IN THE ATMOSPHERE: CLOSE TO THE SEA, INDUSTRIAL ENVIRONMENT WITH CHLORIDE EMISSIONS AND/OR HUMIDITY > 70%), WE RECOMMEND APPLYING SOLVENT-BASED OIL TO THE ENTIRE MACHINE.

N.B.-:WHILE THE MACHINE IS NOT IN USE, CARE MUST BE TAKEN TO BRING THE MACHINE TO THE FULLY STOWED POSITION. ENSURE THAT THE MACHINE IS LOCKED IN A SECURE LOCATION, AND ALL KEYPAD LEDS ARE OFF TO PREVENT UNAUTHORISED USE OF THE MACHINE.

1.2 Decal content

The purpose of the labels on the machine is to alert the user to the conditions of use and risks related to aerial work platforms.

Decals provide the following information :

- The level of severity.
- The specific hazard.
- A method to avoid, suppress or reduce the hazard.
- Descriptive text (where required).

Familiarize yourself with the decals and the hazard severity levels.

The labels must be kept in good condition, otherwise they must be replaced.

Familiarize yourself with the decals and their respective color codes.

Additional decals can be ordered from HAULOTTE Services®.

CE, UKCA, AS and EAC standards - Label warning risk



Marking	Description
1	Risk identification symbol
2	Avoidance symbol pictorial

CE, UKCA, AS and EAC standards - Label informing about an important function of the machine

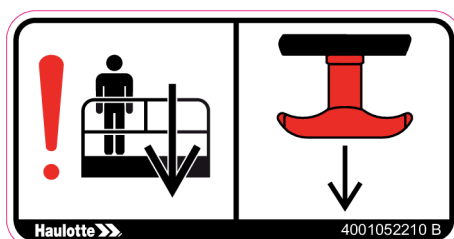











B - Familiarization

ANSI and CSA standards



Marking	Description
1	Risk identification symbol
2	Level of severity
3	Avoidance symbol pictorial
4	Avoidance text

1.3 Level of severity





















Color	Title	Description
		Danger : Indicates a hazardous situation which if not avoided, WILL result in death or serious injury.
		Warning : Indicates a hazardous situation which if not avoided, COULD result in death or serious injury.
		Caution : Failure to comply could result in minor or moderate injury.
		Notice : Indicates recommended practices if not followed, may result in a malfunction or damage the machine or its components.
		Procedure : Indicates a maintenance operation.

B - Familiarization















1.4 Symbols legend and definitions

Symbols are used throughout this manual to depict hazards, avoidance measures and indicate when information is required.

Refer to the following table to familiarize yourself with these symbols.

Symbol	Description	Symbol	Description	Symbol	Description
	Risk of crushing or pinning		Foot crushing hazard		High pressure fluid ejection hazard
			Hand crushing hazard		Crushing hazard
			Health/safety hazards related to chemicals		Burn hazard
	Risk of electrocution		Burns and scalds from contact with flames, explosion or radiation from heat sources		Injury from Electric arcs - Energy supply disconnecting devices - Batteries fire, emissions, etc
	Fall hazard		Tip over due to excessive loading / wind load and excessive ground slope		Relate and coordinate directional arrows on the chassis with those on the control box
	Do not put foot in this area		Do not put your hand in this area		Keep away from product working area
	Use of high-pressure cleaners prohibited		Ensure entry drop rail is down		

B - Familiarization







Symbol	Description	Symbol	Description	Symbol	Description
	Flames prohibited		Maintain safe clearance from high voltage electrically charged conductors as described in manual - Do not use in thunderstorms		Overload
	Refer to operator manual		Safety belt		Use appropriate lanyard attached to dedicated anchor point.
	Wheel pressure		Enable switch		Use safety prop before attempting any maintenance work
	Tow point		Tie down point		Lift point
	Keep away from hot surfaces		Wear protective equipment		

B - Familiarization

1.5 Symbols and colors

Symbols and colors are used to alert the operator of safety precautions and/or to highlight important safety information.

The following safety symbols are used throughout this manual to indicate specific hazards and the hazard severity level when operating or maintaining the Aerial Work Platform.

Symbol	Description
	Danger : Risk of injury or death
	Caution : Risk of material damage
	Prohibited action
	Reminder to use good practice or follow pre-operation checks
	Cross-reference to another part of the manual
	Cross-reference to another manual
	Cross-reference to repair (contact HAULOTTE Services®)
N.B. :	Additional technical information

B - Familiarization

2 Primary machine components

2.1 Layout

COMPACT 8N AE (COMPACT 2032E AE) - COMPACT 10N AE (COMPACT 2632E AE) - COMPACT 10 AE
 (COMPACT 2647E AE) - COMPACT 12 AE (COMPACT 3247E AE) - COMPACT 14 AE (COMPACT 3947E AE)

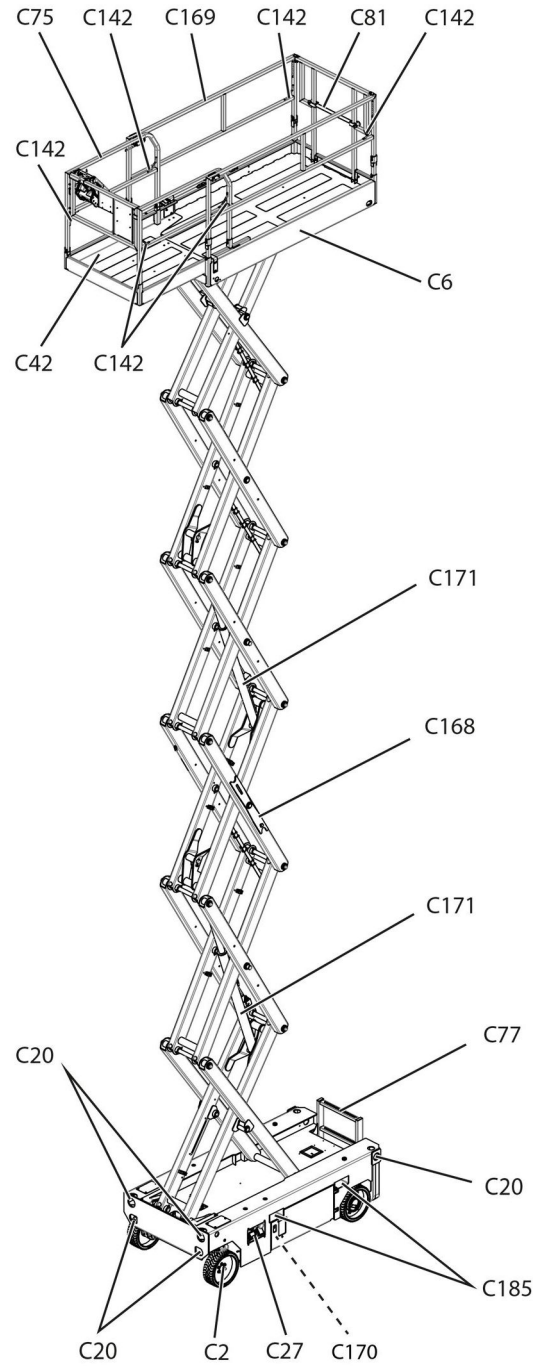
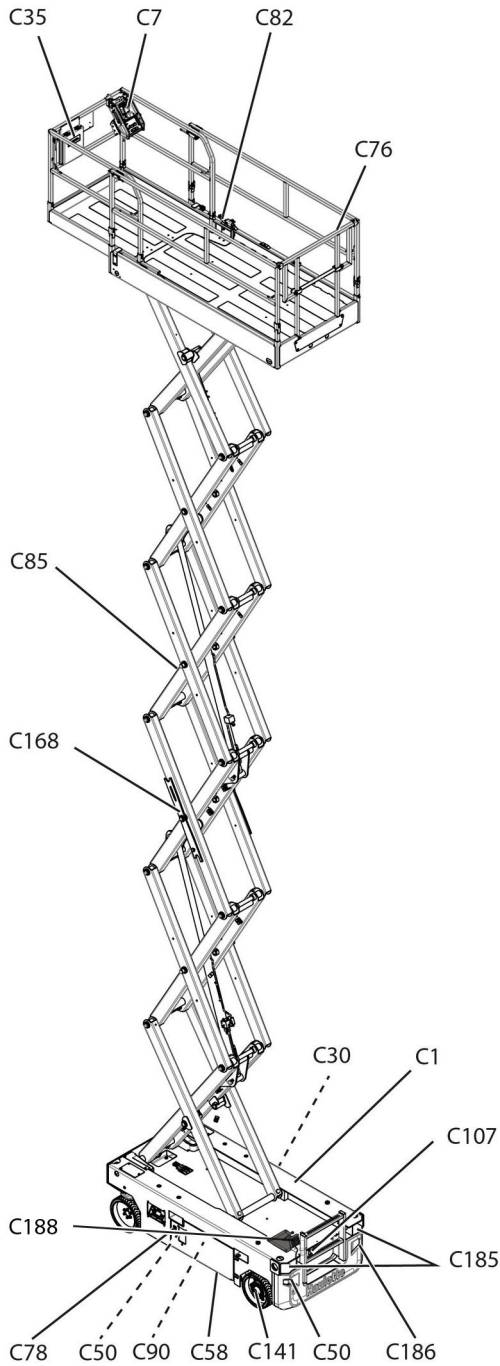

B - Familiarization





Marking	Description	Marking	Description
C1	Chassis	C81	Sliding guardrail
C2	Front steer wheels	C82	Unlock pedal extension deck
C6	Platform	C85	Extending structure (scissor arms)
C7	Platform control box	C90	Battery box
C20	Anchorage point	C107	Pull T-handle for emergency lowering
C27	Ground control box+Universal plug	C141	Rear drive wheels
C30	Hydraulic oil tank	C142	Lanyard attachment points
C35	Document holder	C168	Maintenance support
C42	Foot Switch (Optional)	C169	Folding guardrails
C50	Battery charger socket (Depending on country)	C170	Brake release switch
C58	Pothole protection	C171	Scissors lifting cylinder
C75	Extension deck	C185	Fork pockets
C76	Guardrail	C186	Platform power socket (Optional)
C77	Platform access ladder	C188	Access control keypad
C78	Battery compartment locking catch		

B - Familiarization

2.2 Maintenance support

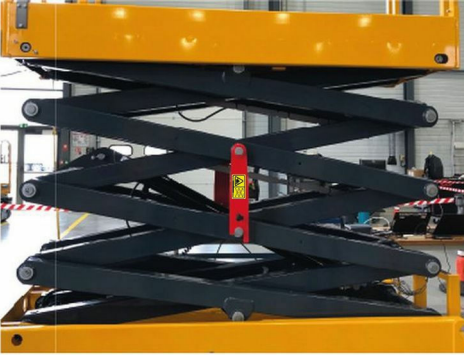
The maintenance stand must be in place before any maintenance operation can begin : Please see machine configuration.

Maintenance support

COMPACT 8N AE (COMPACT 2032E AE)	COMPACT 10N AE (COMPACT 2632E AE) - COMPACT 10 AE (COMPACT 2647E AE)	COMPACT 12 AE (COMPACT 3247E AE) - COMPACT 14 AE (COMPACT 3947E AE)
		
 x2	 x2	 x2

Placing the extending structure into the maintenance configuration :

- Empty the platform of all loads.
- Lift the work platform to a height sufficient to put the maintenance stands in place.
- Loosen the locking screw of the stands.
- Rotate and place the stands in the vertical position.
- The stands must remain in the vertical position.
- Lower the platform again.
- The stand must come to rest on the axis of the scissors.
- For COMPACT 12 AE (COMPACT 3247E AE) - COMPACT 14 AE (COMPACT 3947E AE) : Check that the supports are on the upper and lower axes of the stands.
- Continue to lower the platform until it is fully immobilized.

Put the extending structure into the use position :

- Raise the work platform to a height sufficient to clear the maintenance stands from the scissor axis.
- Rotate the maintenance stands to align them with the scissor arm.
- Reposition the locking screw in its housing.
- Re-tighten the locking screw of the stands.
- Ensure proper functionality.
- Lower the platform again.

B - Familiarization

2.3 Extension deck



Perform the extension manoeuvres :

- On a flat and horizontal surface.
- Extension free from people and loads.
- Guardrails raised and locked.

To extend the extension deck :

- Press the pedal (1) to release the extension deck lock pin.



- Once the pedal (1) is depressed, deploy the guardrail (2) while releasing the pedal.
- Move the platform into one of the 3 possible positions.
- Move in and out to ensure the correct locking. The extension must not move.



Make sure that the extension deck is in locked position. Be aware of the extended platform position when moving the machine.

To retract the extension deck :

- Press pedal (1) and pull the extension deck rails (2) inwards to the locked position.
- Release the pedal.

B - Familiarization

2.4 Ground control box

2.4.1 Layout

General view

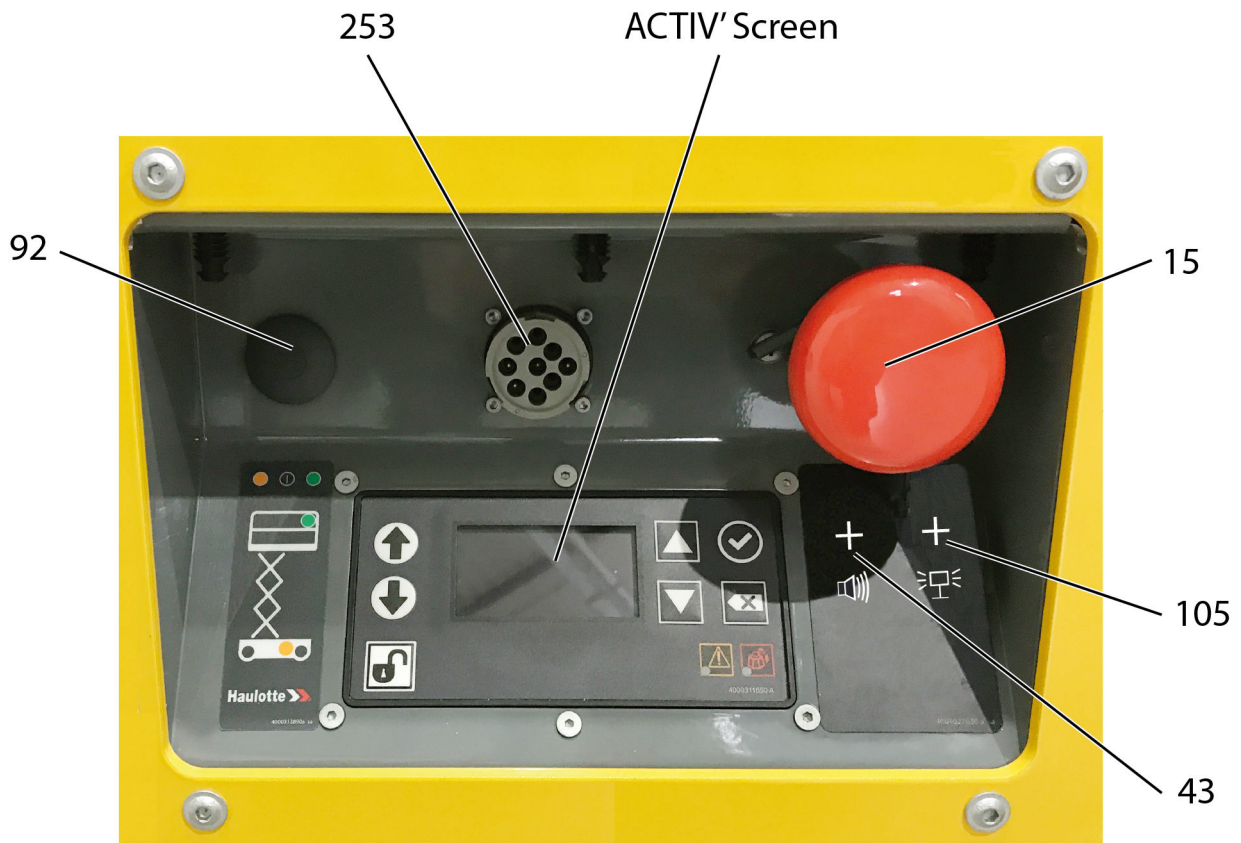

Controls and indicators

Marking	Name	Description	Function
15	SB801	E-stop button	Pulled out : Button deactivated
			Press in : Button activated. The entire machine is off
43		Horn button	Option
92	SA901	Control box activation key switch	Not used
105		Beacon light	Option
253	CN03	Diagnostic tool socket	Connection to the diagnostic tool (HaulotteDiag)

B - Familiarization

2.4.2 Access control keypad

Located near the ground control box, the access control keypad allows authorized users to enter a valid code to turn on/off the machine and select a control box location.

General view



Commands

Marking	Function	Description
0 - 9	Enter the code	Enter the correct access code by using the buttons from 0 to 9.
ENTER	Press the ENTER button to validate the code	The ground control box is only energized if the correct code is entered. If the wrong code is entered, then pressing enter does nothing.
GRND (1)	Press the GRND button to use the ground control box	De-energize platform control box and energize ground control box.
PLTFM (2)	Press the PLTFM button to use the platform control box	De-energize ground control box and energize platform control box.
OFF	Press the OFF button to turn off power to the machine	Machine is powered off.

B - Familiarization

2.4.2.1 Indicators

General view

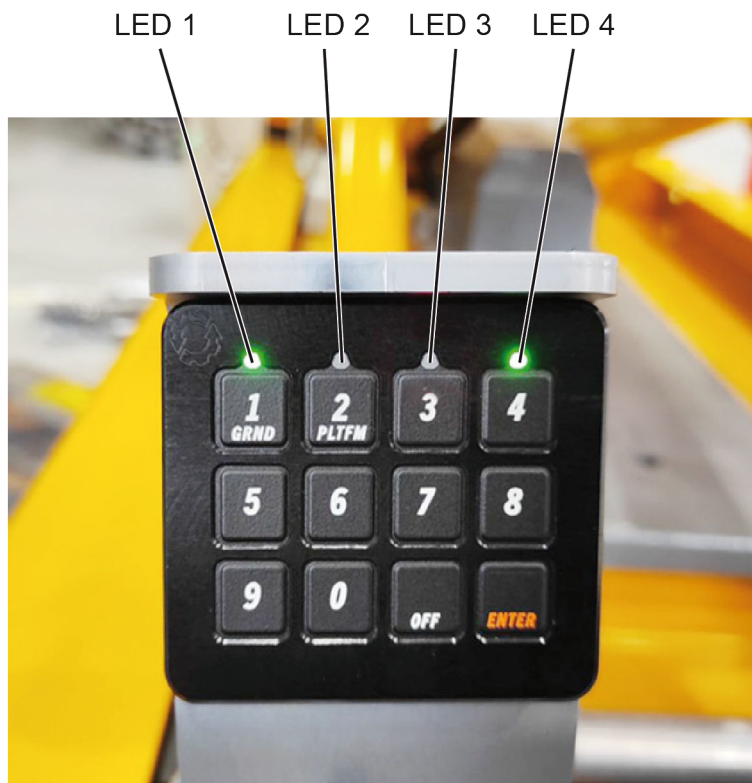

Indicators

Marking	Function
LED 1	Green - Ground control box energized Flashing red - Invalid code entered
LED 2	Blue - Any button press Green - Platform control box energized
LED 3	Flashing red or blue - Communication error (Contact HAULOTTE Service®)
LED 4	Green - Machine powered ON Not lit - Machine switched off

B - Familiarization

2.4.3 HAULOTTE Activ'Screen

Upon starting and during operation of the machine, the LCD screen "Activ'Screen" located on the ground control box displays in real time the machine operating status.

HAULOTTE Activ'Screen

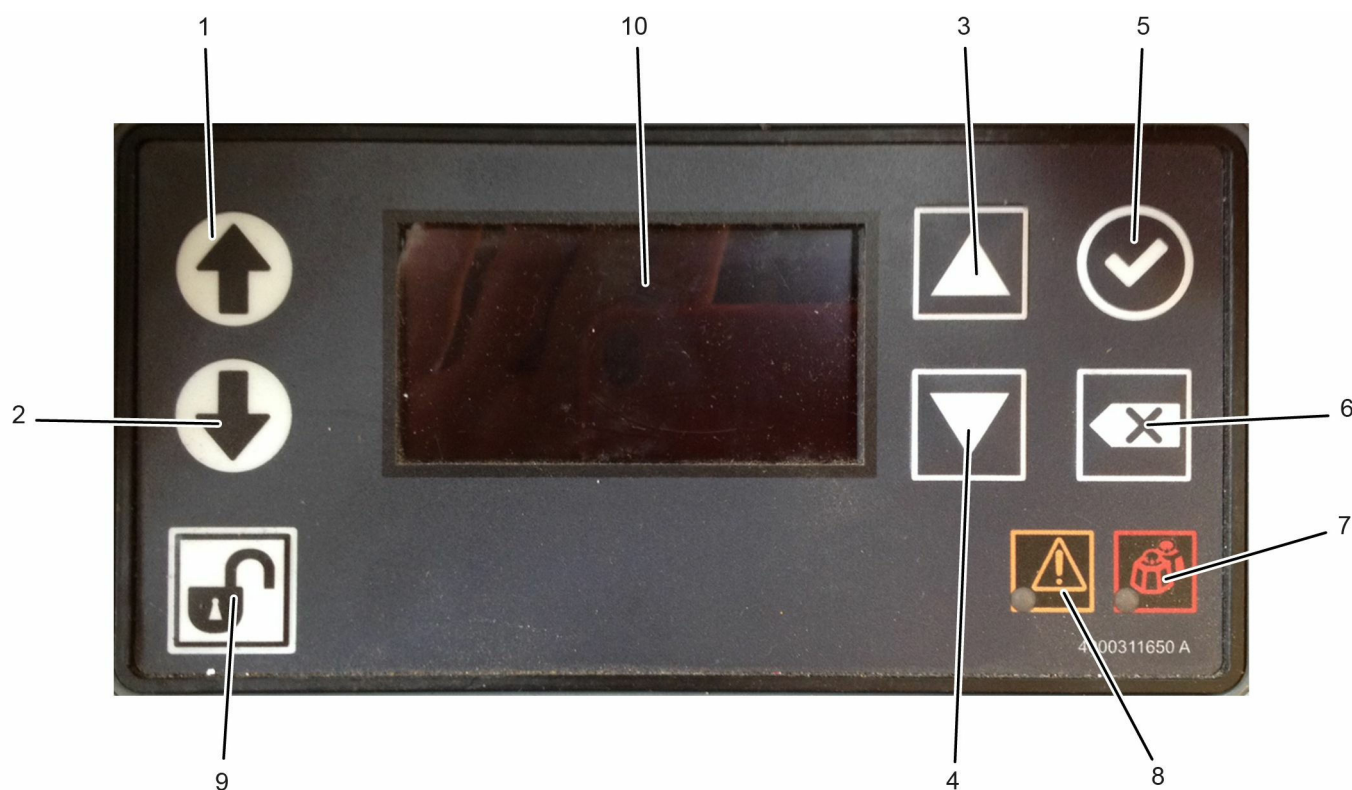

Controls and indicators

Marking	Description	Function
1	Platform raising control	Platform raises
2	Platform lowering control	Platform lowers
3	Navigation button	Navigation of menu to select function-Scroll up
4	Navigation button	Navigation of menu to select function-Scroll down
5	Confirmation button	Menu validation button
6	Cancellation button	Go back
7	Platform overload indicator	Platform overload indicator - Charging malfunction ⁽¹⁾
8	Machine fault indicator	Operation malfunction - Charging malfunction ⁽¹⁾
9	Enable Switch	Press in and hold : Authorization of movements
10	LCD screen	Display status of operation of the machine

⁽¹⁾ Refer to  D 7.1.3 - Fault codes

B - Familiarization

2.4.3.1 LCD screen







The system triggers the automatic controls on start up

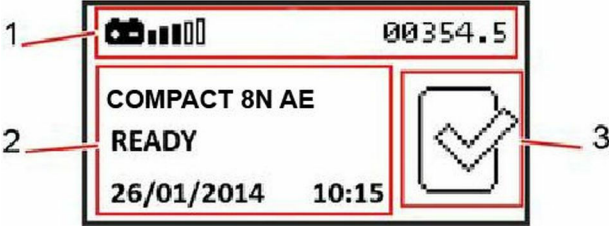

- Bars fill up showing the progress of the automatic checks.

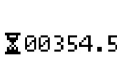

- Home screen comes on with status icon of the machine - okay to proceed functioning the controls.





Home screen (Will be visible - depending on the machine)

Icon	Description	Icon	Function
			
1	Functional information zone		- Battery charge status
			- Maintenance required
			- Alarm detected
			- Machine's total running hours - The timer flashes if the hourmeter increases
2	Text area	COMPACT 8N AE	
		READY	- Machine ready. Displayed when no fault is detected and no other machine status icon is active
		26/01/2014 10:15	- Machine date and time
3	Machine status zone		- Machine ready. Displayed when no fault is detected and no other machine status icon is active

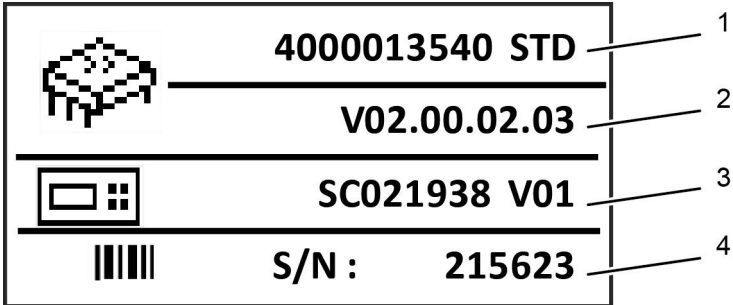

Pressing the  or  buttons enables navigation of the following menus :

B - Familiarization

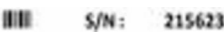
Information screen (Will be visible - depending on the machine)



Icon	Description	Icon	Function
			
1	Information text		- Software part number
2	Information text		- Software version
3	Information text		- Screen identification+Screen software version
4	Information text		- Machine serial number

Maintenance mode access screen (Will be visible - depending on the machine)

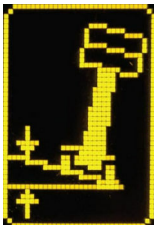
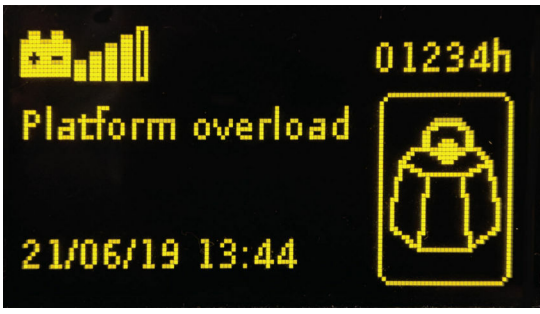

Icon	Icon	Function
		- Maintenance mode access screen-Refer to the maintenance manual to enter the access code-Validation by pressing on is active only if access code is known and entered - refer to maintenance manual for the procedure for the different level code usage

B - Familiarization

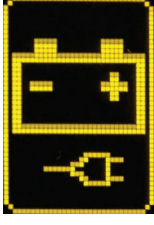
Machine status screen (Will be visible - depending on the machine)

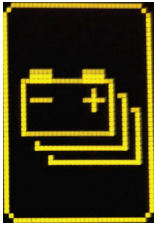

Icon	Icon	Function
 <p>Machine Tilted 21/06/19 13:43</p>		<p>Machine on a slope greater than the permitted limits</p>
 <p>Platform overload 21/06/19 13:44</p>		<p>Machine overloaded : The load on the lifting platform is greater than the permitted maximum load</p>
 <p>LOW BATTERY 21/06/19 13:45</p>		<p>Low battery</p>

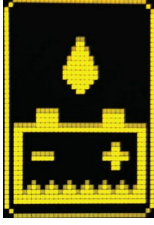
Machine status screen (Will be visible - depending on the machine)

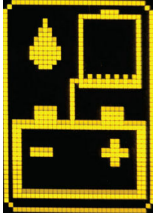

Icon	Icon	Function
 <p>Battery recharge 12/07/19 11:50</p>		<ul style="list-style-type: none"> - Fully recharge the batteries <p>N.B. : To perform a full recharge, the battery level must be less than 70 % .</p>
 <p>Low water level ba 12/07/19 11:49</p>		<ul style="list-style-type: none"> - Low battery water level (Optional)

B - Familiarization

Machine status screen (Will be visible - depending on the machine)

Icon	Icon	Function
		- Low water tank level (Optional)
		SGS - Secondary Guarding System is deactivated

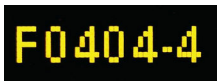
Example of a fault code display on the machine (Will be visible - depending on the machine)

Icon	Icon	Function
		- Fault code-If there is a fault with the machine :  Refer to the Service Manual

(1) For machines fitted with

B - Familiarization



2.5 Platform control box

2.5.1 Layout

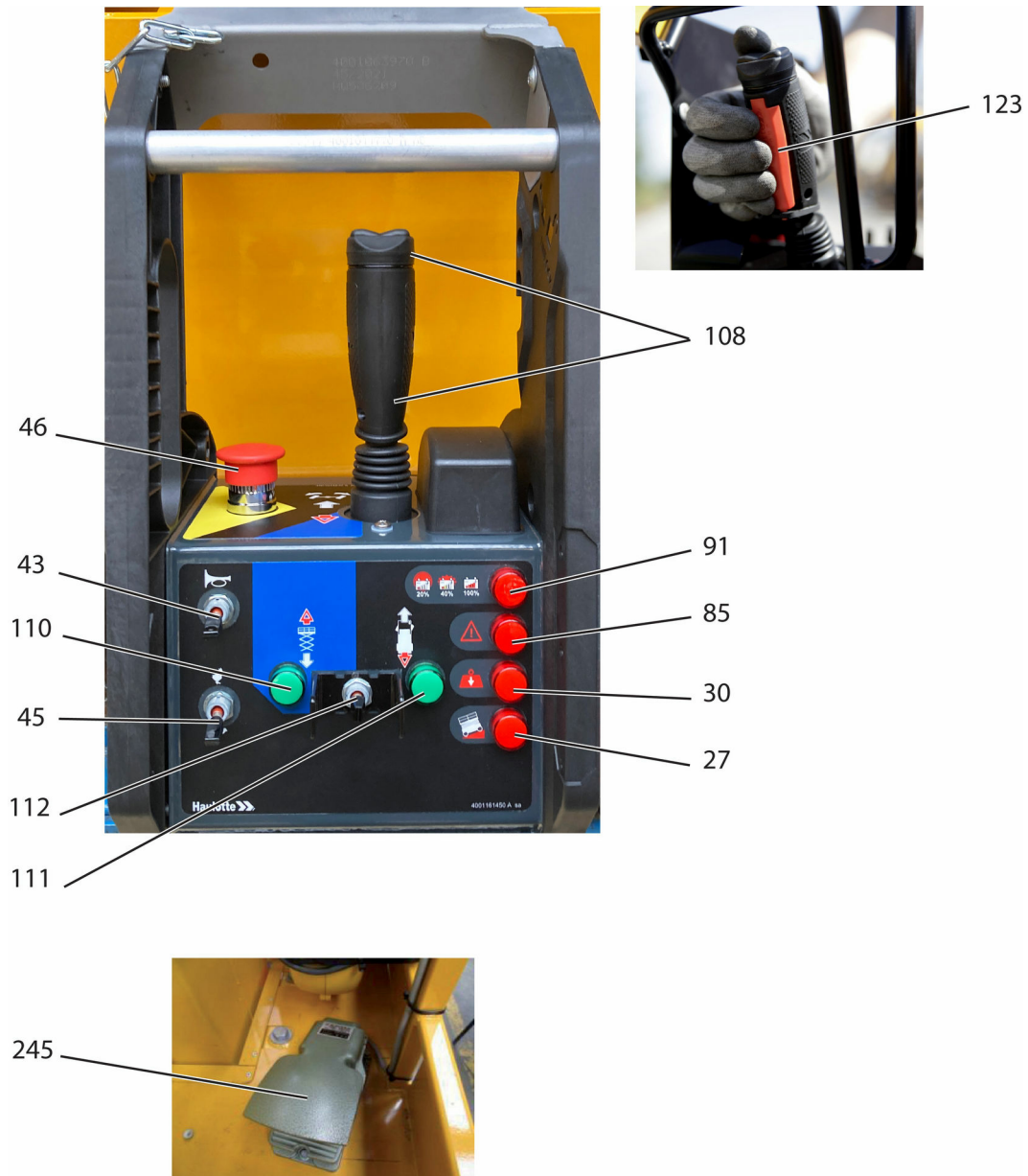

General view



Controls and indicators

Marking	Item	Description	Function
27	HL800	Tilt indicator	Machine on excessive slope
30	HL802	Overload indicator	Platform overloaded
43	SA907	Horn button	Move upwards and hold to activate horn
45	SA110	Drive Speed Selector	Move upwards :  high-speed driving
			Move downwards :  low-speed driving

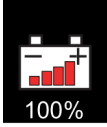
B - Familiarization

Marking	Item	Description	Function
46	SB802	E-stop button	Pulled out : Button deactivated
			Press in : Button activated. The entire machine is off
85	HL903	Fault indicator	Presence of a fault
91	HL904	Battery charging indicator	 100% Off : Battery charged (Between 41 % and 100 %)
			 40% Flashing: Batteries have 40 % charge left
			 20% Constantly on: Batteries have 20 % charge left
108	SM901	Movement joystick	Move downwards : Forward drive or platform lowering
			Move upwards : Reverse drive or platform lifting
		Front axle steering selector	Press right side of button : Right-hand steering
			Press left side of button : Left-hand steering
110	HL420	Lifting/lowering indicator light	On : Raising / Lowering selection activated
			Off : Raising / Lowering movement is not selected
111	HL100	Drive indicator light	On : Driving function activated
			Off : Driving movement is not selected
112	SA908	2-position selector	Move to the left : Platform raising / lowering
			Move to the right : Drive movements
123	SA901	Enable Switch	Press in and hold : Authorization of movements
245	SB800	Foot Switch (Optional)	Press in and hold: Authorization of movements

B - Familiarization

3 Performance Specifications

3.1 Technical characteristics

Use the table to select the right Haulotte machine for the job.



Do not replace parts that are essential to the stability of the machine, such as batteries or tyres, with parts that have a different weight or different specifications. The stability of the machine could be affected.

Machine	COMPACT 8N AE - COMPACT 2032E AE	
	SI	Imp.
Maximum working height	8,0 m	23 ft 6 in
Maximum platform height	6,0 m	19 ft 8 in
Height of the machine in transport configuration, guardrails folded	1,82 m	6 ft 0 in
Activation height of the micro speed	1,87 m	6 ft 2 in
Total weight	2120 kg	4674 lbs
Maximum load capacity of the work platform	350 kg	772 lbs
Number of extensions	1	
Extension deck length	0,92 m	3 ft 0 in
Maximum extension deck capacity	120 kg	265 lbs
Maximum number of occupants	Indoor use : 2 Outdoor use : 1	
Maximum person on extension (refer to the capacity on extension recommended)	Indoor use : 1 Outdoor use : 1	
Maximum wind speed	Indoor use : 0 km/h (0 m/s) Outdoor use : 45 km/h (12,5 m/s)	Indoor use : 0 mph (0 ft/s) Outdoor use : 28 mph (41 ft/s)
Manual force	Indoor use : 400 N (90 lbf) Outdoor use : 200 N (45 lbf)	
Gradeability (Transport configuration)	25 %	
Maximum side rated slope	1,5°	
Maximum longitudinal rated slope	3,5°	
Maximum load per wheel	1250 kg	2756 lbs
Maximum ground pressure of wheel on paved ground	15,3 daN/cm ²	222 lb/ft ²

B - Familiarization

Machine	COMPACT 8N AE - COMPACT 2032E AE	
Drive speed :		
- Folded machine maximum speed (Transport configuration)	4,2 km/h	2.6 mph
- Unfolded machine maximum speed (Platform raised)	0,7 km/h	0.4 mph
Maximum freewheel speed during towed operation (Towing)	4,2 km/h	2.6 mph
Outside turning radius	2,05 m	6 ft 9 in
Inside turning radius	0,46 m	1 ft 6 in
Hydraulic tank capacity	10 l	2.6 gal US

Characteristics - Performance

Operating temperature	- 20° C / + 50° C (- 4° F / + 122° F)
Storage temperature	- 20° C / + 50° C (- 4° F / + 122° F)

Power source - Electric

Type of battery		Capacity	System voltage	Battery weight
Semi-traction battery	Standard	180Ah (C5)	24V	28 kg(62 lb)
Semi-traction battery	Option	195Ah (C5)	24V	30 kg(66 lb)
Semi-traction battery	Option	170Ah (C5)	24V	32 kg(71 lb)
Semi-traction battery(AGM)	Option	182Ah (C5)	24V	30 kg(66 lb)
Semi-traction battery	Option	170Ah (C5)	24V	32 kg(71 lb)

Machine	COMPACT 10N AE - COMPACT 2632E AE	
Units	SI	Imp.
Maximum working height	9,80 m	32 ft 2 in
Maximum platform height	7,80 m	25 ft 7 in
Height of the machine in transport configuration, guardrails folded	1,94 m	6 ft 4 in
Activation height of the micro speed	2,16 m	7 ft 1 in
Total weight	2160 kg	4762 lbs
Maximum load capacity of the work platform	250 kg	551 lbs
Number of extensions	1	

B - Familiarization

Machine	COMPACT 10N AE - COMPACT 2632E AE	
Extension deck length	0,92 m	3 ft 0 in
Maximum extension deck capacity	120 kg	265 lbs
Maximum number of occupants	Indoor use only : 2	
Maximum person on extension (refer to the capacity on extension recommended)	Indoor use only : 1	
Maximum wind speed	Indoor use only : 0 km/h (0 m/s)	Indoor use only : 0 mph (0 ft/s)
Manual force	Indoor use only : 400 N (90 lbf)	
Gradeability (Transport configuration)	25 %	
Maximum side rated slope	1,5°	
Maximum longitudinal rated slope	3,5°	
Maximum load per wheel	1250 kg	2756 lbs
Maximum ground pressure of wheel on paved ground	15,3 daN/cm ²	222 lb/ft ²
Drive speed :		
- Folded machine maximum speed (Transport configuration)	4,2 km/h	2.6 mph
- Unfolded machine maximum speed (Platform raised)	0,7 km/h	0.4 mph
Maximum freewheel speed during towed operation (Towing)	4,2 km/h	2.6 mph
Outside turning radius	2,05 m	6 ft 9 in
Inside turning radius	0,46 m	1 ft 6 in
Hydraulic tank capacity	10 l	2.6 gal US
Characteristics - Performance		
Operating temperature	- 20° C / + 50° C (- 4° F / + 122° F)	
Storage temperature	- 20° C / + 50° C (- 4° F / + 122° F)	
Power source - Electric		

B - Familiarization

Machine		COMPACT 10N AE - COMPACT 2632E AE		
Type of battery		Capacity	System voltage	Battery weight
Semi-traction battery	Standard	180Ah (C5)	24V	30 kg(66 lb)
Semi-traction battery	Option	195Ah (C5)	24V	30 kg(66 lb)
Semi-traction battery	Option	170Ah (C5)	24V	32 kg(71 lb)
Semi-traction battery(AGM)	Option	182Ah (C5)	24V	30 kg(66 lb)

Machine	COMPACT 10 AE - COMPACT 2647 AE	
Units	SI	Imp.
Maximum working height	10,0 m	32 ft 10 in
Maximum platform height	8,0 m	26 ft 3 in
Height of the machine in transport configuration, guardrails folded	1,65 m	5 ft 5 in
Activation height of the micro speed	2,16 m	7 ft 1 in
Total weight	2490 kg	5490 lbs
Maximum load capacity of the work platform	450 kg	992 lbs
Number of extensions	1	
Extension deck length	0,92 m	3 ft 0 in
Maximum extension deck capacity	120 kg	265 lbs
Maximum number of occupants	Indoor use : 3 Outdoor use : 1	
Maximum person on extension (refer to the capacity on extension recommended)	Indoor use : 1 Outdoor use : 1	
Maximum wind speed	Indoor use : 0 km/h (0 m/s) Outdoor use : 45 km/h (12,5 m/s)	Indoor use : 0 mph (0 ft/s) Outdoor use : 28 mph (41 ft/s)
Manual force	Indoor use : 400 N (90 lbf) Outdoor use : 200 N (45 lbf)	
Gradeability (Transport configuration)	25 %	
Maximum side rated slope	1,5°	
Maximum longitudinal rated slope	3,5°	

B - Familiarization

Machine	COMPACT 10 AE - COMPACT 2647 AE	
Maximum load per wheel	1450 kg	319 lbs
Maximum ground pressure of wheel on paved ground	15,7 daN/cm ²	227.7 lb/ft ²
Drive speed :		
- Folded machine maximum speed (Transport configuration)	4,2 km/h	2.6 mph
- Unfolded machine maximum speed (Platform raised)	0,7 km/h	0.4 mph
Maximum freewheel speed during towed operation (Towing)	4,2 km/h	2.6 mph
Outside turning radius	1,83 m	6 ft 0 in
Inside turning radius	0,59 m	1 ft 1 in
Hydraulic tank capacity	10 l	2.6 gal US

Characteristics - Performance

Operating temperature	- 20° C / + 50° C (- 4° F / + 122° F)
Storage temperature	- 20° C / + 50° C (- 4° F / + 122° F)

Power source - Electric

Type of battery		Capacity	System voltage	Battery weight
Semi-traction battery	Standard	180Ah (C5)	24V	28 kg(62 lb)
Semi-traction battery	Option	195Ah (C5)	24V	30 kg(66 lb)
Semi-traction battery	Option	170Ah (C5)	24V	32 kg(71 lb)
Semi-traction battery(AGM)	Option	182Ah (C5)	24V	30 kg(66 lb)
Semi-traction battery	Option	170Ah (C5)	24V	32 kg(71 lb)

Machine	COMPACT 12 AE - COMPACT 3247 AE	
Units	SI	Imp.
Maximum working height	11,75 m	38 ft 7in
Maximum platform height	9,75 m	32 ft 0 in
Height of the machine in transport configuration, guardrails folded	1,77 m	5 ft 10 in
Activation height of the micro speed	2,48 m	8 ft 2 in

B - Familiarization

Machine	COMPACT 12 AE - COMPACT 3247 AE	
Total weight	2940 kg	6482 lbs
Maximum load capacity of the work platform	320 kg	705 lbs
Number of extensions	1	
Extension deck length	0,92 m	3 ft 0 in
Maximum extension deck capacity	120 kg	265 lbs
Maximum number of occupants	Indoor use : 3 Outdoor use : 1	
Maximum person on extension (refer to the capacity on extension recommended)	Indoor use : 1 Outdoor use : 1	
Maximum wind speed	Indoor use : 0 km/h (0 m/s) Outdoor use : 45 km/h (12,5 m/s)	Indoor use : 0 mph (0 ft/s) Outdoor use : 28 mph (41 ft/s)
Manual force	Indoor use : 400 N (90 lbf) Outdoor use : 200 N (45 lbf)	
Gradeability (Transport configuration)	25 %	
Maximum side rated slope	1,5°	
Maximum longitudinal rated slope	3,5°	
Maximum load per wheel	1800 kg	3969 lbs
Maximum ground pressure of wheel on paved ground	18,9 daN/cm ²	274 lb/ft ²
Drive speed :		
- Folded machine maximum speed (Transport configuration)	4,2 km/h	2.6 mph
- Unfolded machine maximum speed (Platform raised)	0,7 km/h	0.4 mph
Maximum freewheel speed during towed operation (Towing)	4,2 km/h	2.6 mph
Outside turning radius	1,83 m	6 ft 0 in
Inside turning radius	0,59 m	1 ft 11 in
Hydraulic tank capacity	14 l	4 gal US
Characteristics - Performance		
Operating temperature	- 20° C / + 50° C (- 4° F / + 122° F)	
Storage temperature	- 20° C / + 50° C (- 4° F / + 122° F)	
Power source - Electric		

B - Familiarization

Machine		COMPACT 12 AE - COMPACT 3247 AE		
Type of battery		Capacity	System voltage	Battery weight
Semi-traction battery	Standard	180Ah (C5)	24V	28 kg(62 lb)
Semi-traction battery	Option	195Ah (C5)	24V	30 kg(66 lb)
Semi-traction battery	Option	170Ah (C5)	24V	32 kg(71 lb)
Semi-traction battery(AGM)	Option	182Ah (C5)	24V	30 kg(66 lb)

Machine	COMPACT 14 AE - COMPACT 3947 AE	
Units	SI	Imp.
Maximum working height	13,75 m	45 ft 1 in
Maximum platform height	11,75 m	38 ft 7 in
Height of the machine in transport configuration, guardrails folded	2,02 m	6 ft 8 in
Transport configuration limit height	2,88 m	9 ft 5 in
Total weight	3070 kg	6768 lbs
Maximum load capacity of the work platform	320 kg	705 lbs
Number of extensions	1	
Extension deck length	0,92 m	3 ft 0 in
Maximum extension deck capacity	120 kg	265 lbs
Maximum number of occupants	Indoor use only : 3	
Maximum person on extension (refer to the capacity on extension recommended)	Indoor use only : 1	
Maximum wind speed	Indoor use only : 0 km/h (0 m/s)	Indoor use only : 0 mph (0 ft/s)
Manual force	Indoor use only : 400 N (90 lbf)	
Gradeability (Transport configuration)	25 %	
Maximum side rated slope	1,5°	
Maximum longitudinal rated slope	3,5°	
Maximum load per wheel	1800 kg	3969 lbs
Maximum ground pressure of wheel on paved ground	18,9 daN/cm ²	274 lb/ft ²

B - Familiarization

Machine	COMPACT 14 AE - COMPACT 3947 AE	
Drive speed :		
- Folded machine maximum speed (Transport configuration)	4,2 km/h	2.6 mph
- Unfolded machine maximum speed (Platform raised)	0,7 km/h	0.4 mph
Maximum freewheel speed during towed operation (Towing)	4,2 km/h	2.6 mph
Outside turning radius	1,83 m	6 ft 0 in
Inside turning radius	0,59 m	1 ft 11 in
Hydraulic tank capacity	14 l	4 gal US

Characteristics - Performance

Operating temperature	- 20° C / + 50° C (- 4° F / + 122° F)
Storage temperature	- 20° C / + 50° C (- 4° F / + 122° F)

Power source - Electric

Type of battery		Capacity	System voltage	Battery weight
Semi-traction battery	Standard	180Ah (C5)	24V	28 kg(62 lb)
Semi-traction battery	Option	195Ah (C5)	24V	30 kg(66 lb)
Semi-traction battery	Option	170Ah (C5)	24V	32 kg(71 lb)
Semi-traction battery(AGM)	Option	182Ah (C5)	24V	30 kg(66 lb)
Semi-traction battery	Option	170Ah (C5)	24V	32 kg(71 lb)

B - Familiarization

3.2 Working area / Range of motion

COMPACT 8N AE-COMPACT 2032E AE

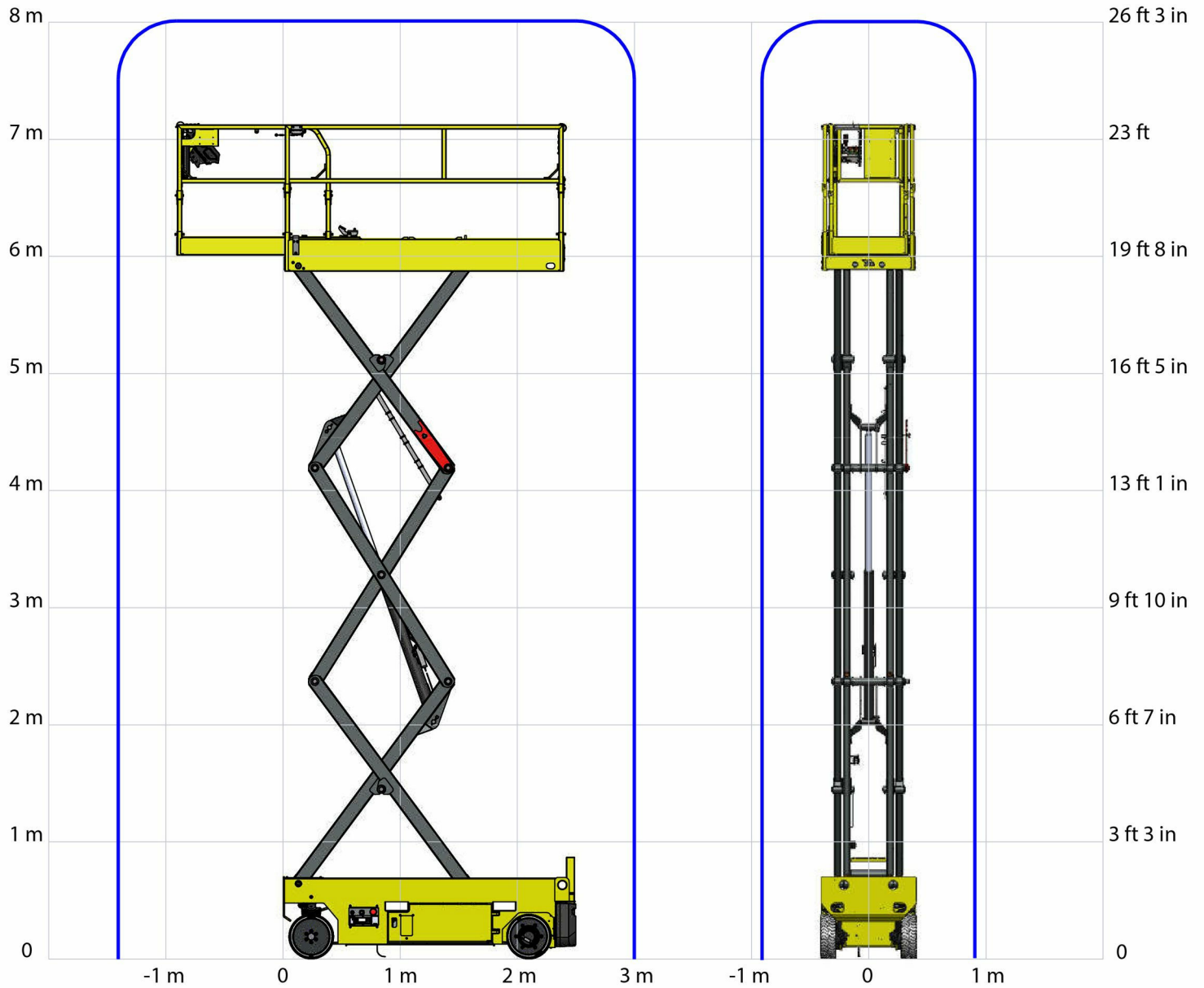

B - Familiarization

COMPACT 10N AE-COMPACT 2632E AE

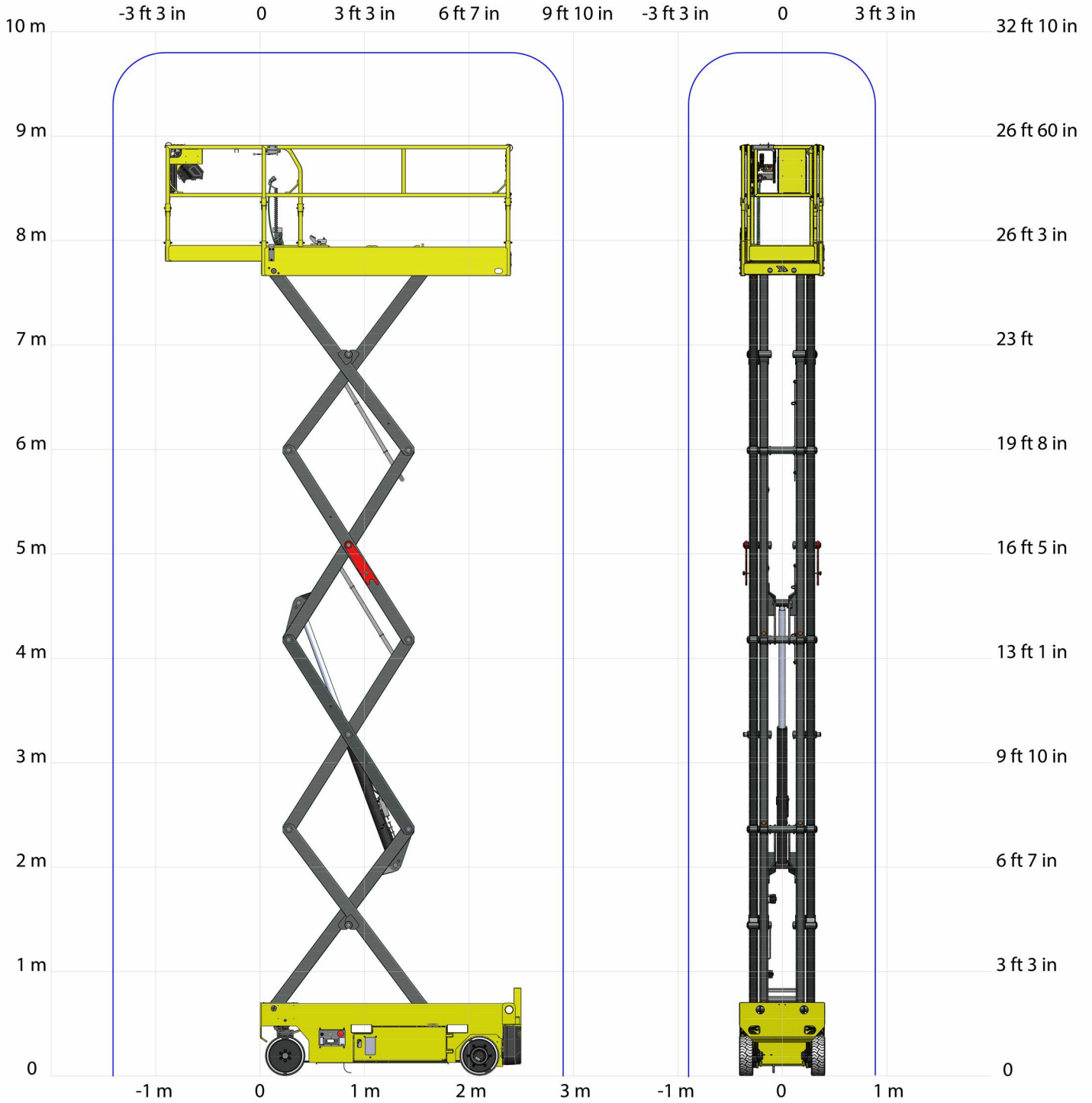

B - Familiarization

COMPACT 10 AE-COMPACT 2647E AE

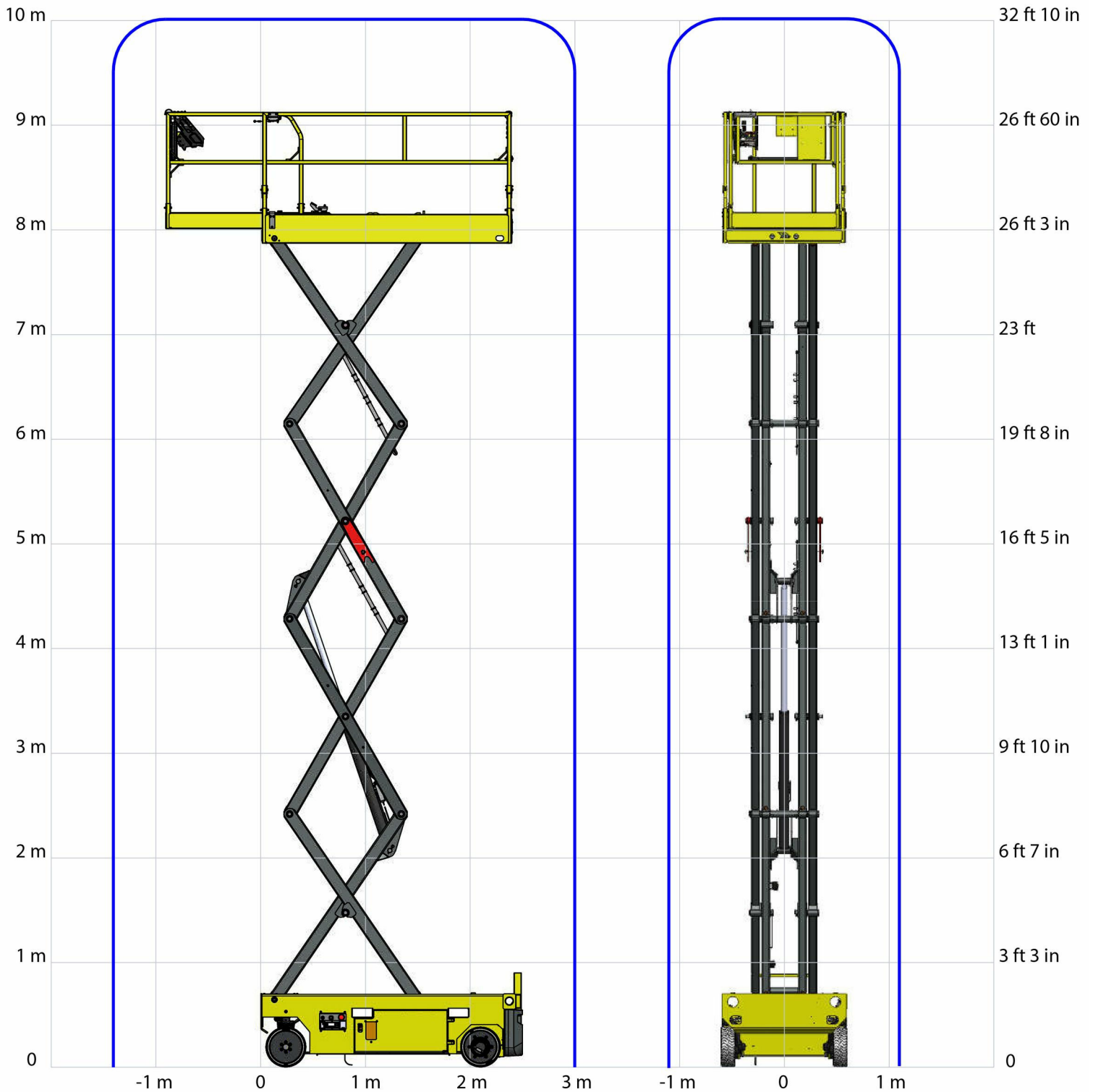

B - Familiarization

COMPACT 12 AE-COMPACT 3247E AE

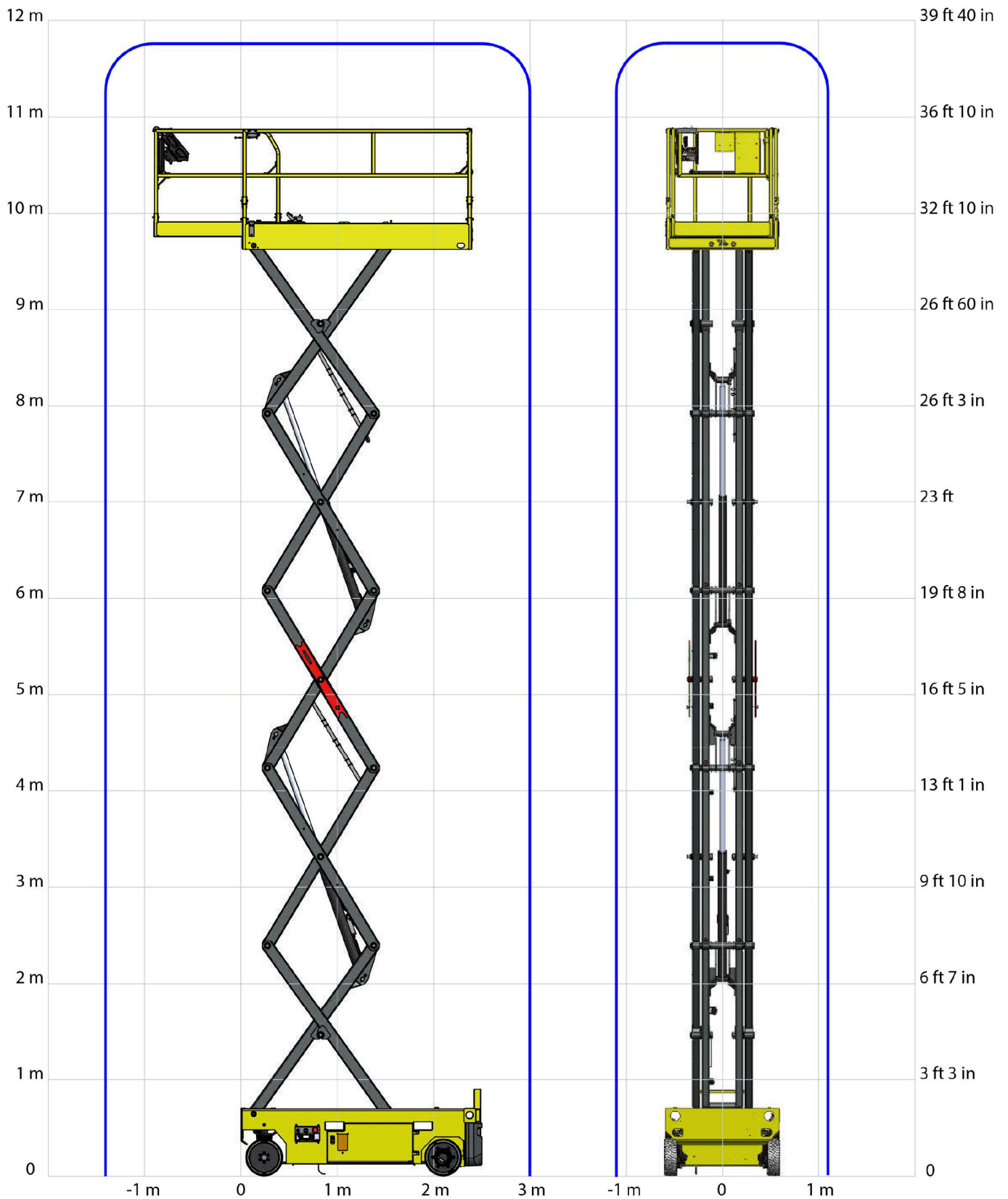

B - Familiarization

COMPACT 14 AE-COMPACT 3947E AE

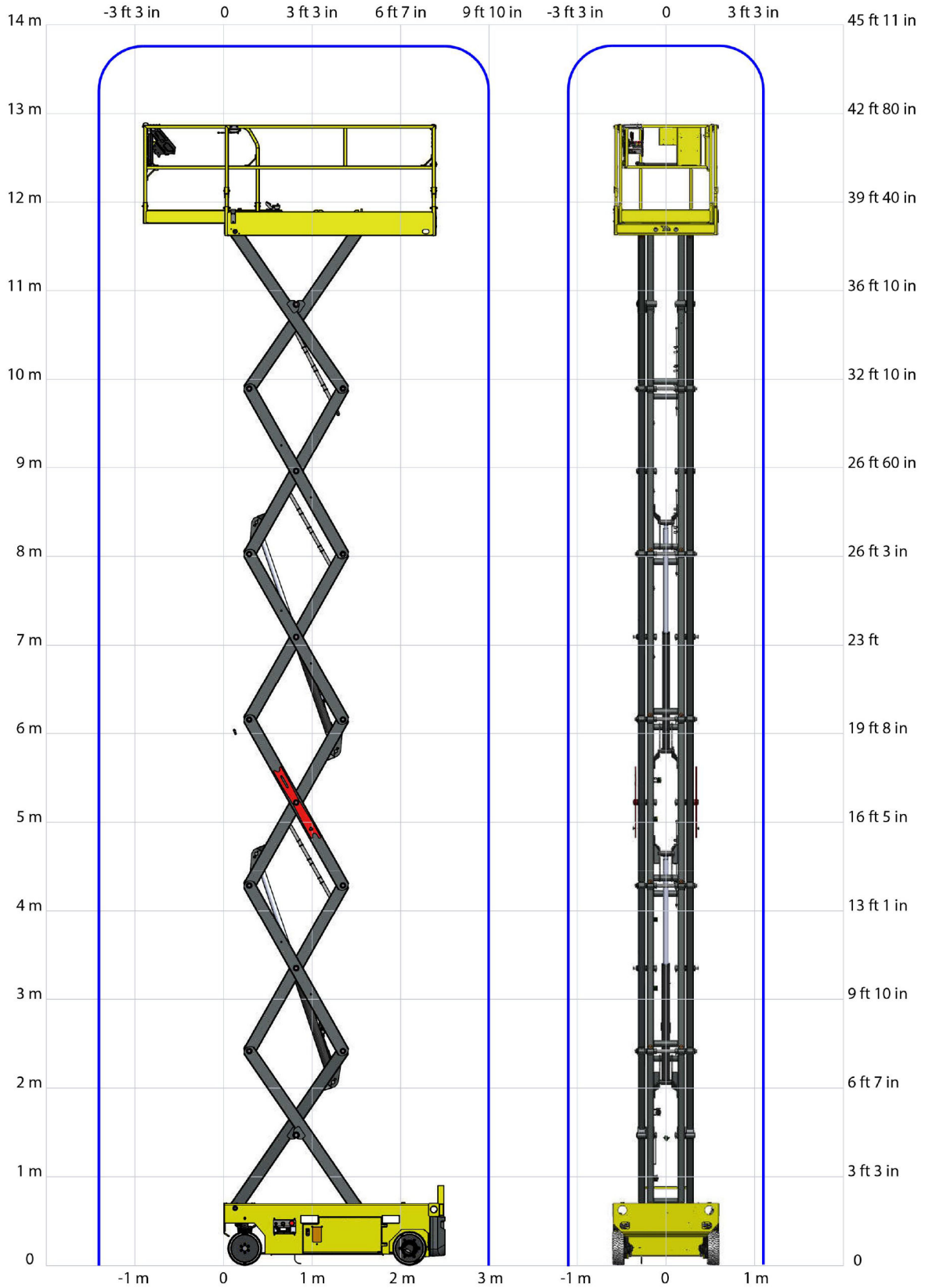

B - Familiarization

4 Decals and markings locations

CE, UKCA, AS and EAC standards-4001186850 - COMPACT 8N AE - COMPACT 10N AE

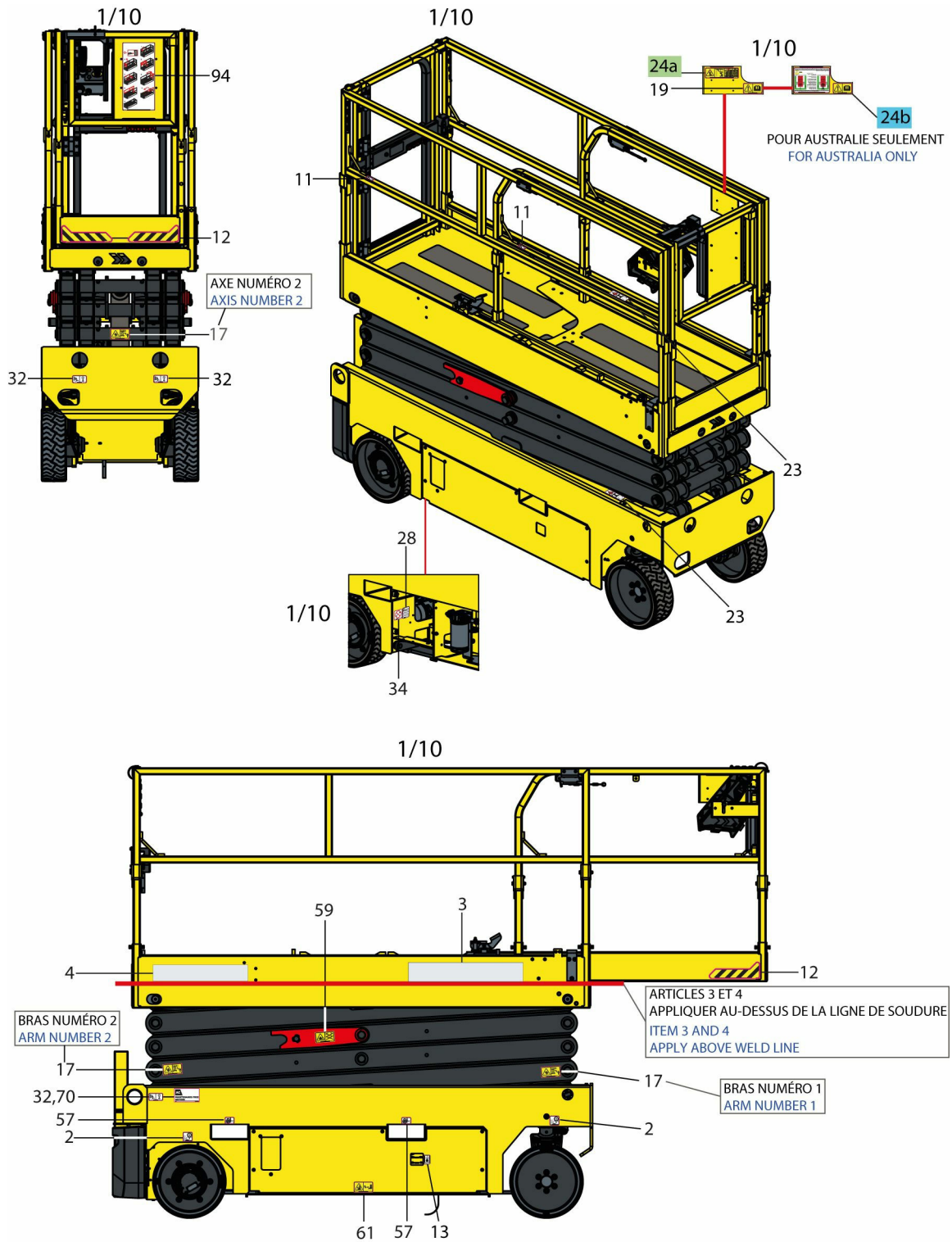

B - Familiarization

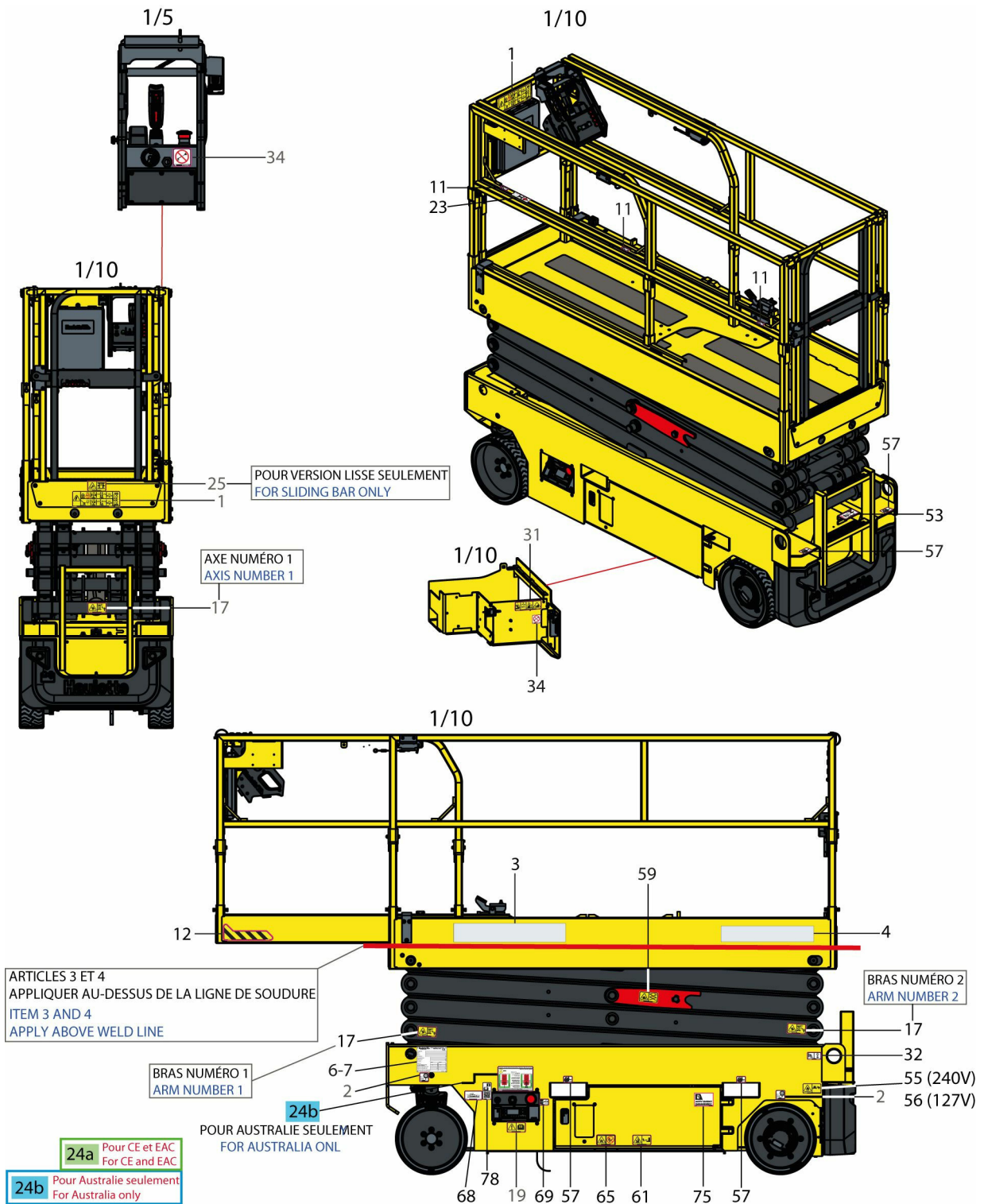

B - Familiarization

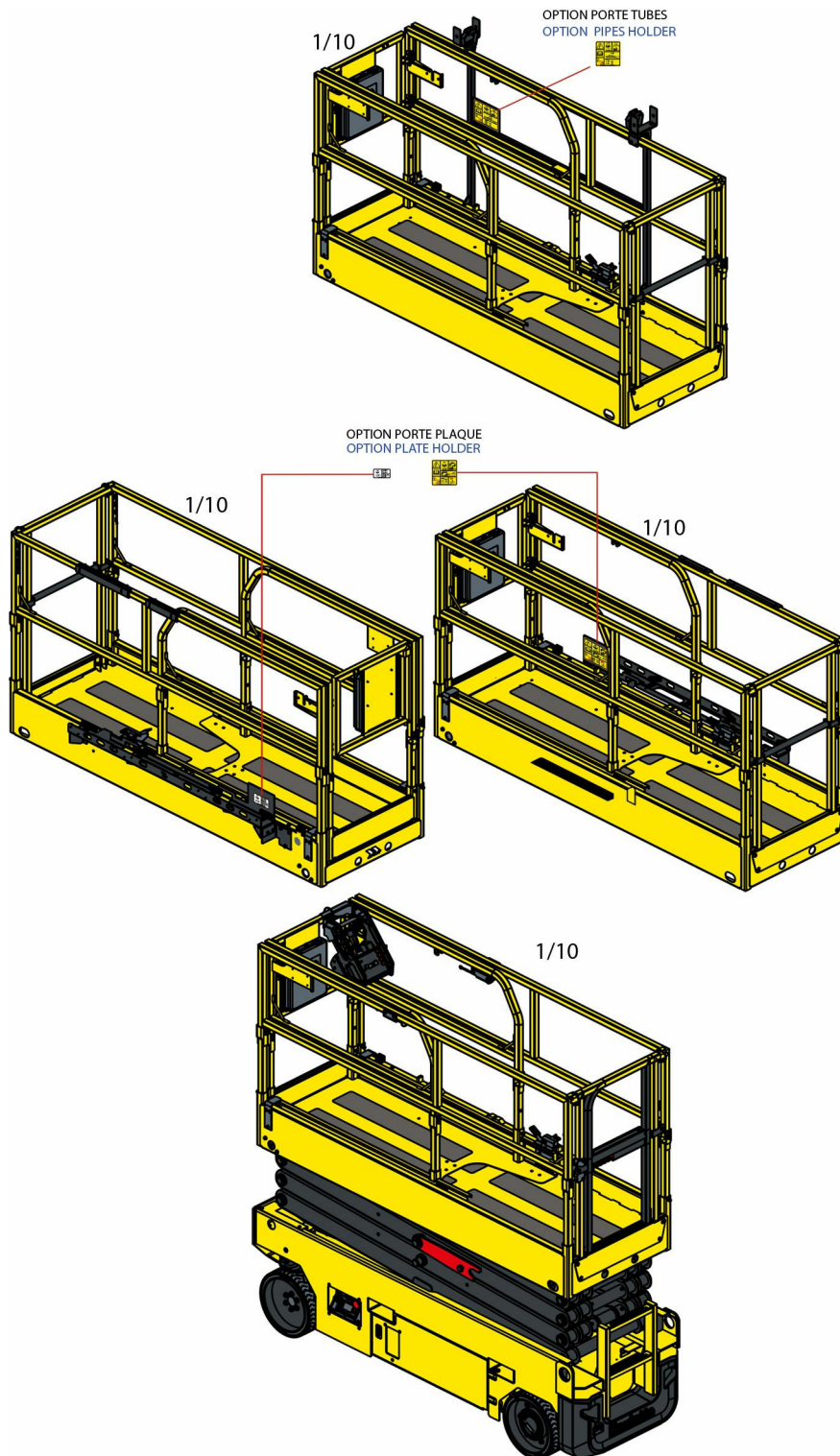

B - Familiarization

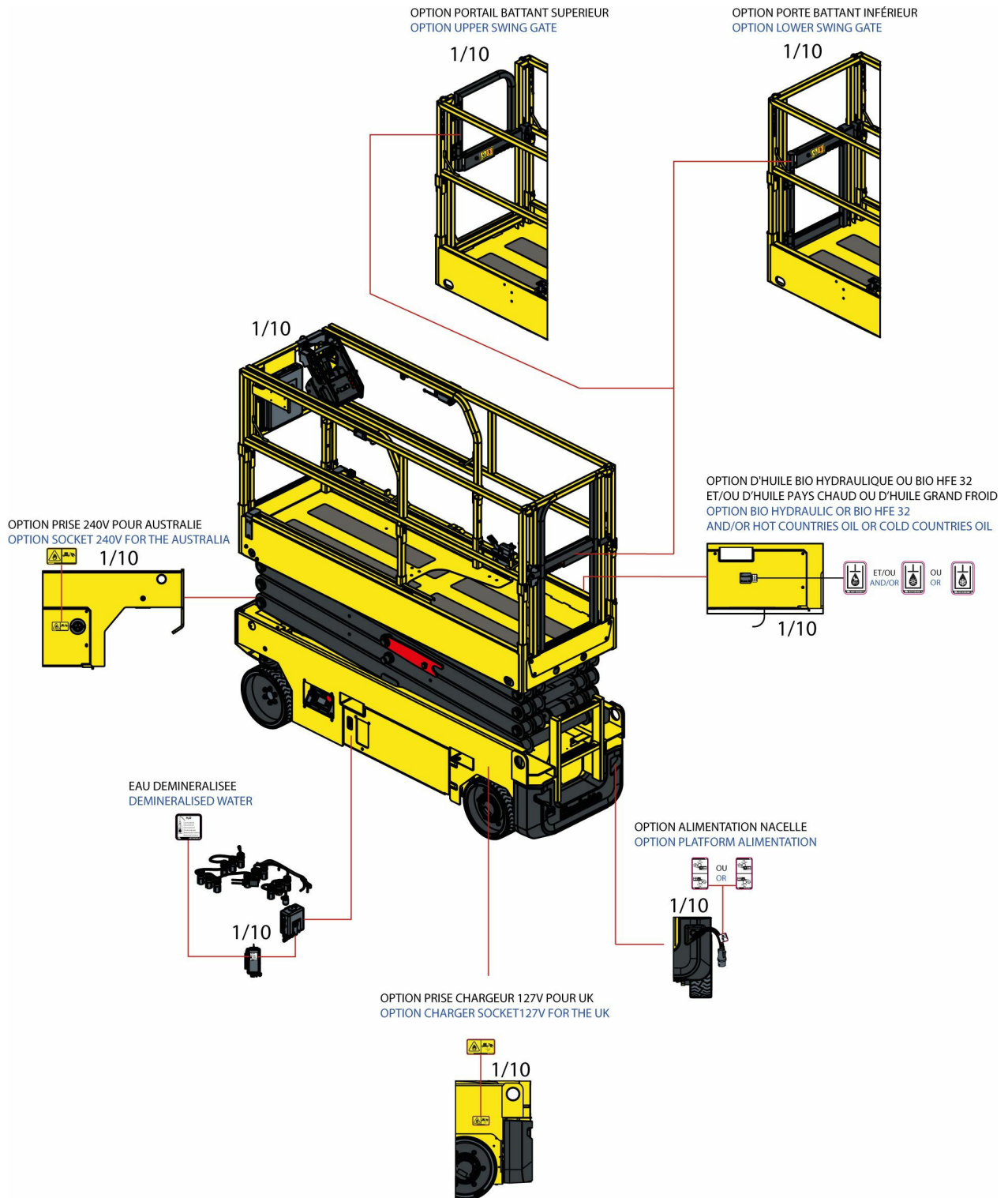

B - Familiarization

CE, UKCA, AS and EAC standards-4001186850 - COMPACT 8N AE - COMPACT 10N AE

Marking	Description	Quantity	
1	Height of the floor and load	2	For COMPACT 8N AE : 4001185770 For COMPACT 10N AE : 4001185780
2	Maximum Pressure per Tire - Floor Loading	4	4001194320
3	Commercial name-Bright machine	2	For COMPACT 8N AE : 4001185890 For COMPACT 10N AE : 4001185910
3	Commercial name-Dark machine	2	For COMPACT 8N AE : 4001185900 For COMPACT 10N AE : 4001185920
4	Decal HAULOTTE®-Bright machine	2	4001072210
4	Decal HAULOTTE®-Dark machine	2	4001072220
6	Identification plate	1	For CE, UCKA and AS standards only : 4001243970 For Russia : 4000388680 For Ukraine : 4000054150
7	Rivet	4	2421803570
11	Lanyard attachment points	5	4001052020
12	Material risk-Yellow and black adhesive tape	2	4001052030
13	Hydraulic oil	1	4001052050
17	Risk of crushing	6	4001052070
19	Read the operation manual	2	4001052090
23	Driving direction	3	4001052110
24a	Danger of electrocution	1	For CE, UKCA and EAC standards only: 4001052120
24b	Danger of electrocution	2	For AS standard only: 4001052140
25	Risk of crushing-Closing drop rail	1	4001052150
28	Software version	1	4000504670
31	Brake release	1	4001052170
32	Anchorage point-Traction	4	4001052180
34	Risk of electrocution-Water projection	3	4001052200
53	Emergency lowering-T-handle	1	4001052210
55	Risk of electrocution-Charger- 240 V	1	4001110960

B - Familiarization

Marking	Description	Quantity	
56	Risk of electrocution-Charger- 127 V	1	4001110970
57	Position of the lift truck forks	6	4001052230
59	Scissors safety	2	For COMPACT 8N AE : 4001052240 For COMPACT 10N AE : 4001052250
61	Risk of crushed feet	2	4001052260
65	Hazard-Battery	1	4001052270
68	Information-Transport height	1	For COMPACT 8N AE : 4001187080 For COMPACT 10N AE : 4001187090
69	Information-Battery isolation switch	1	4001052290
70	Information- AC MAINTENANCE-FREE MOTORS -Bright machine	1	4001053450
70	Information- AC MAINTENANCE-FREE MOTORS -Dark machine	1	4001053500
75	Information- ACTIV' ENERGY MANAGEMENT -Bright machine	1	4001053460
75	Information- ACTIV' ENERGY MANAGEMENT -Dark machine	1	4001053510
78	QR Code ( https://www.e-technical-information.com)	1	4001089310
94	Information-Folding guardrails	1	4001196420
Not illustrated	Compressed air option	1	4001052370
Not illustrated	Pipe holder option	1	4001194340
Not illustrated	Plate holder option	1	4001199540 4001199550
Not illustrated	Centralized filling option	1	4001052340
Not illustrated	Plate holder option HFE 32	1	4001052380 4001052400
Not illustrated	Biodegradable hydraulic oil option-Cold country	1	4001052390
Not illustrated	Swing door option-Maximum	1	4001052080
Not illustrated	Swing door option-Minimum	1	4001052080
Not illustrated	Power plug option	1	4001052350 / 4001052360
Not illustrated	Option 127 V charger socket	1	4001110970
Not illustrated	Option 240 V charger socket	1	4001110960

B - Familiarization

Marking	Description	Quantity	
Not illustrated	Folding guardrails option	1	4001222350
			4001222360
			4001222370
			4001222380
			4001222390
			4001222400

B - Familiarization

CE, UKCA, AS and EAC standards-4001188080 - COMPACT 10 AE - COMPACT 12 AE - COMPACT 14 AE

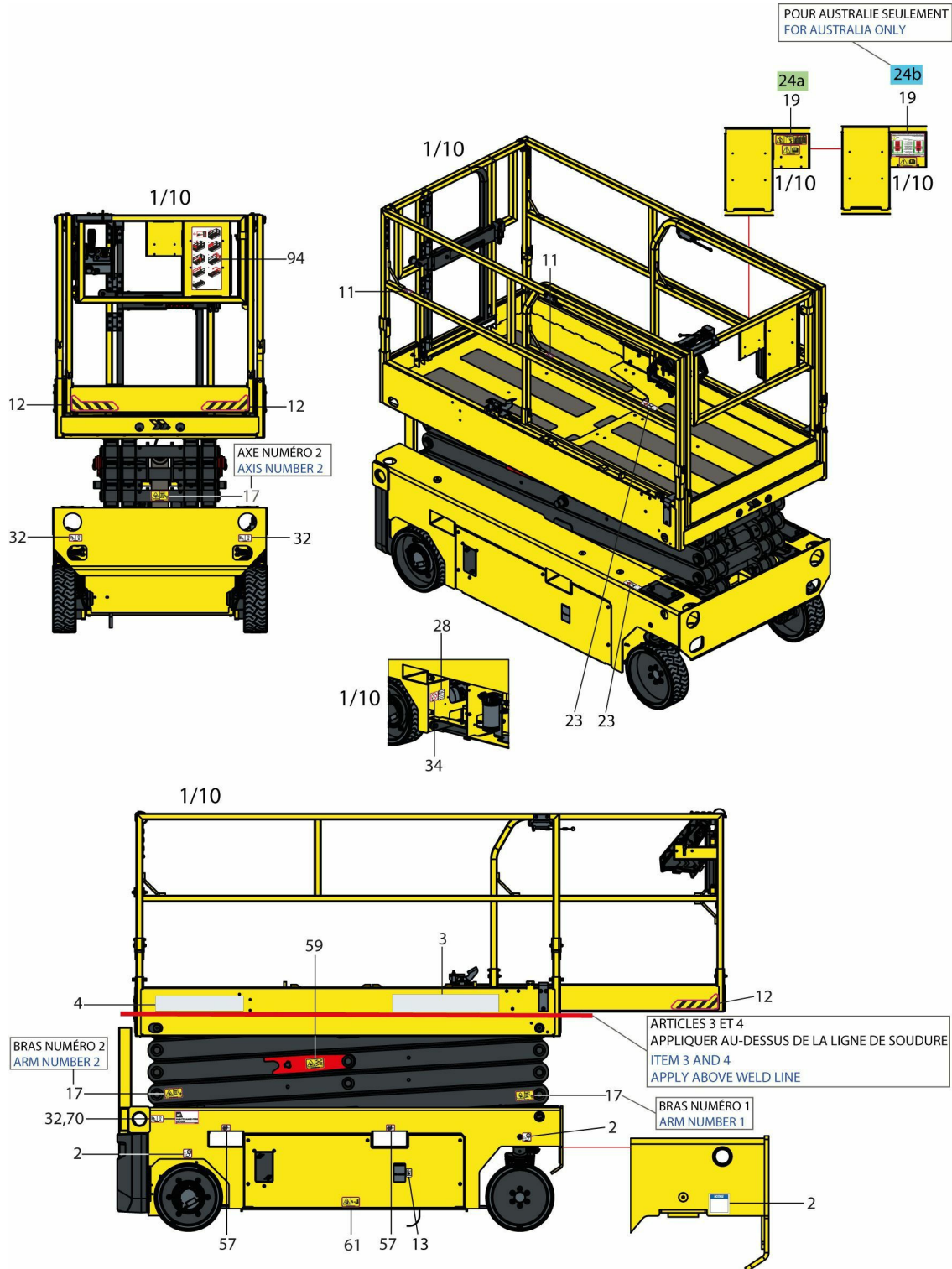

B - Familiarization

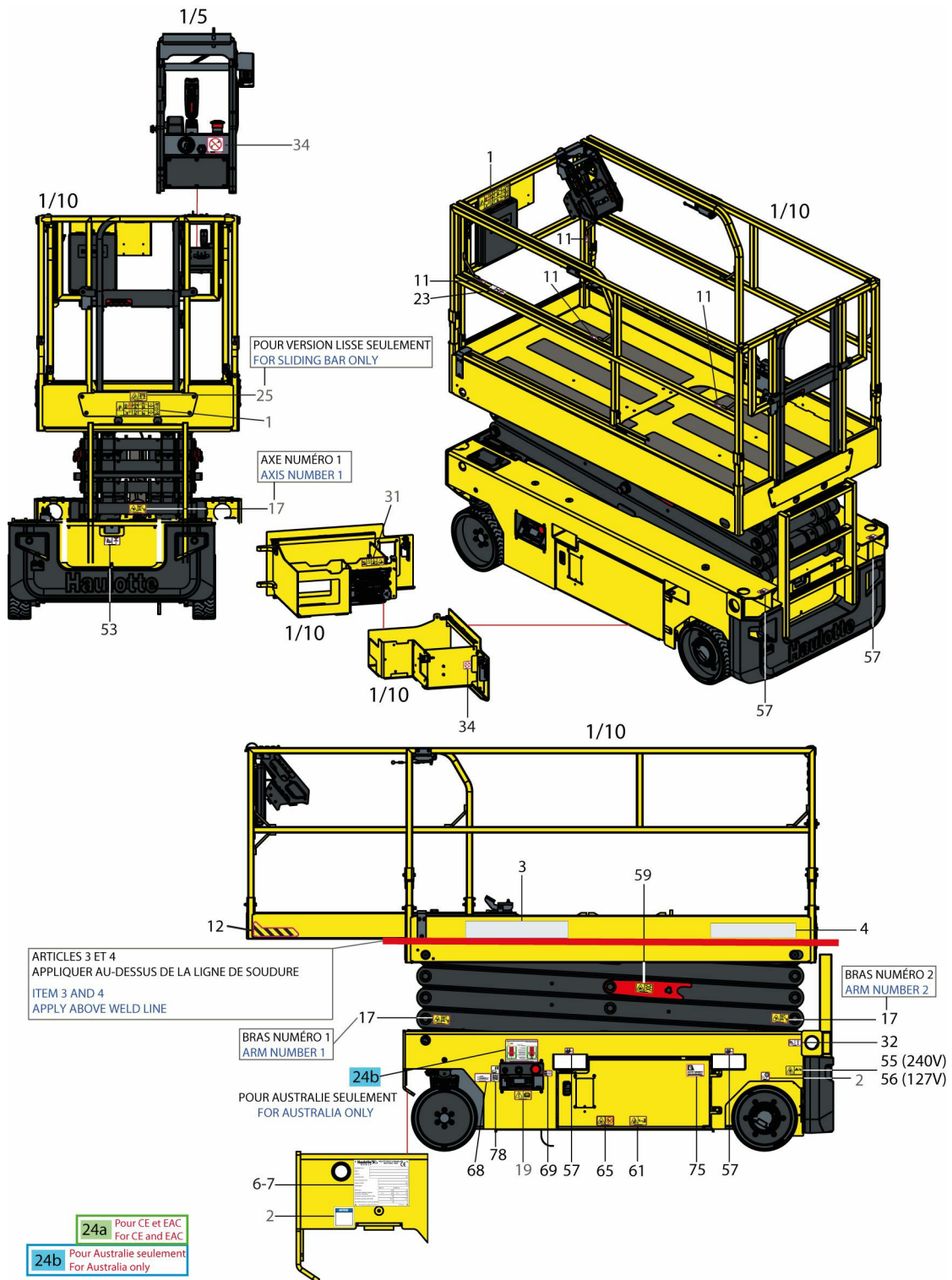

24a Pour CE et EAC
For CE and EAC

24b Pour Australie seulement
For Australia only

B - Familiarization

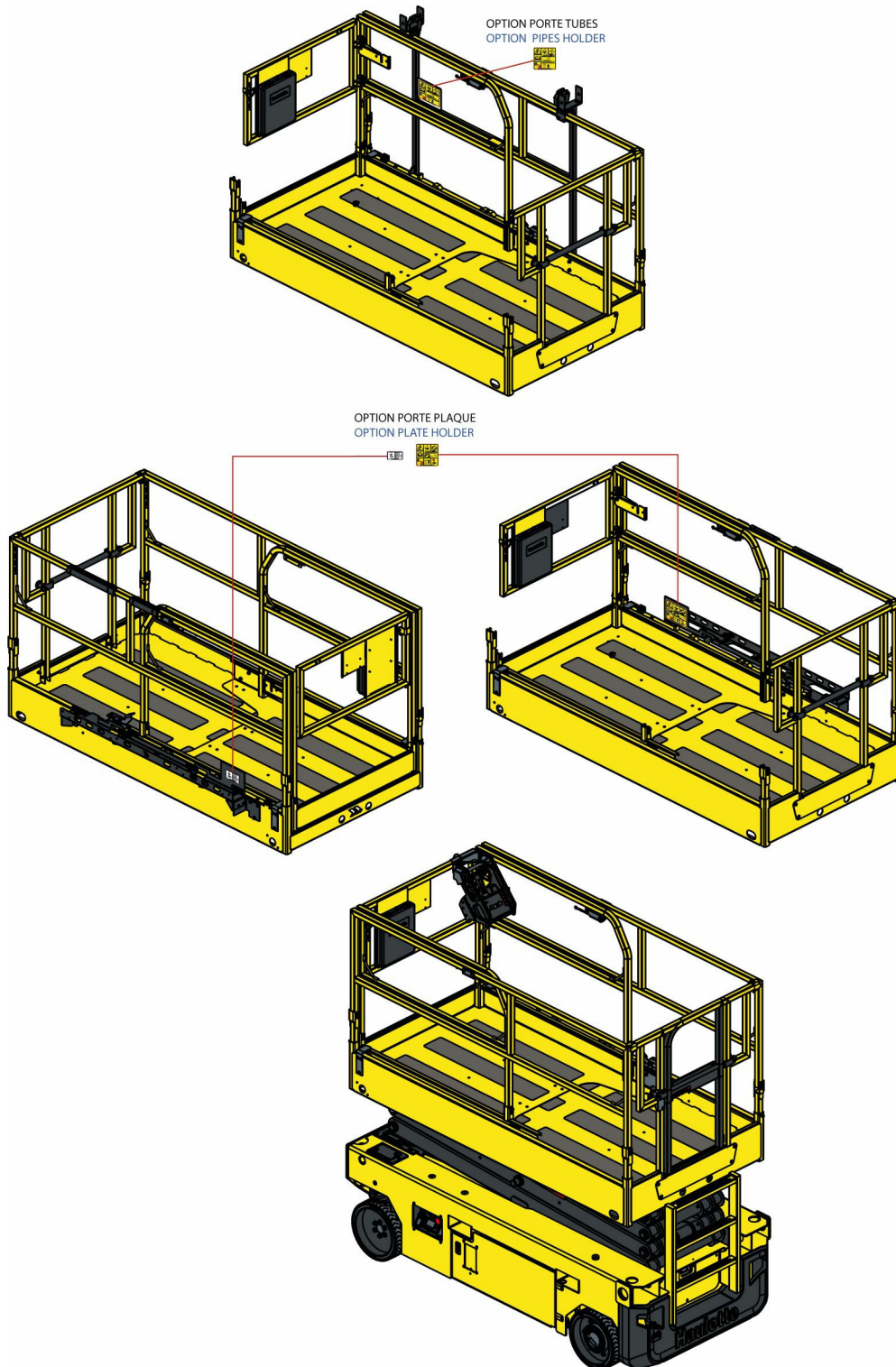

B - Familiarization

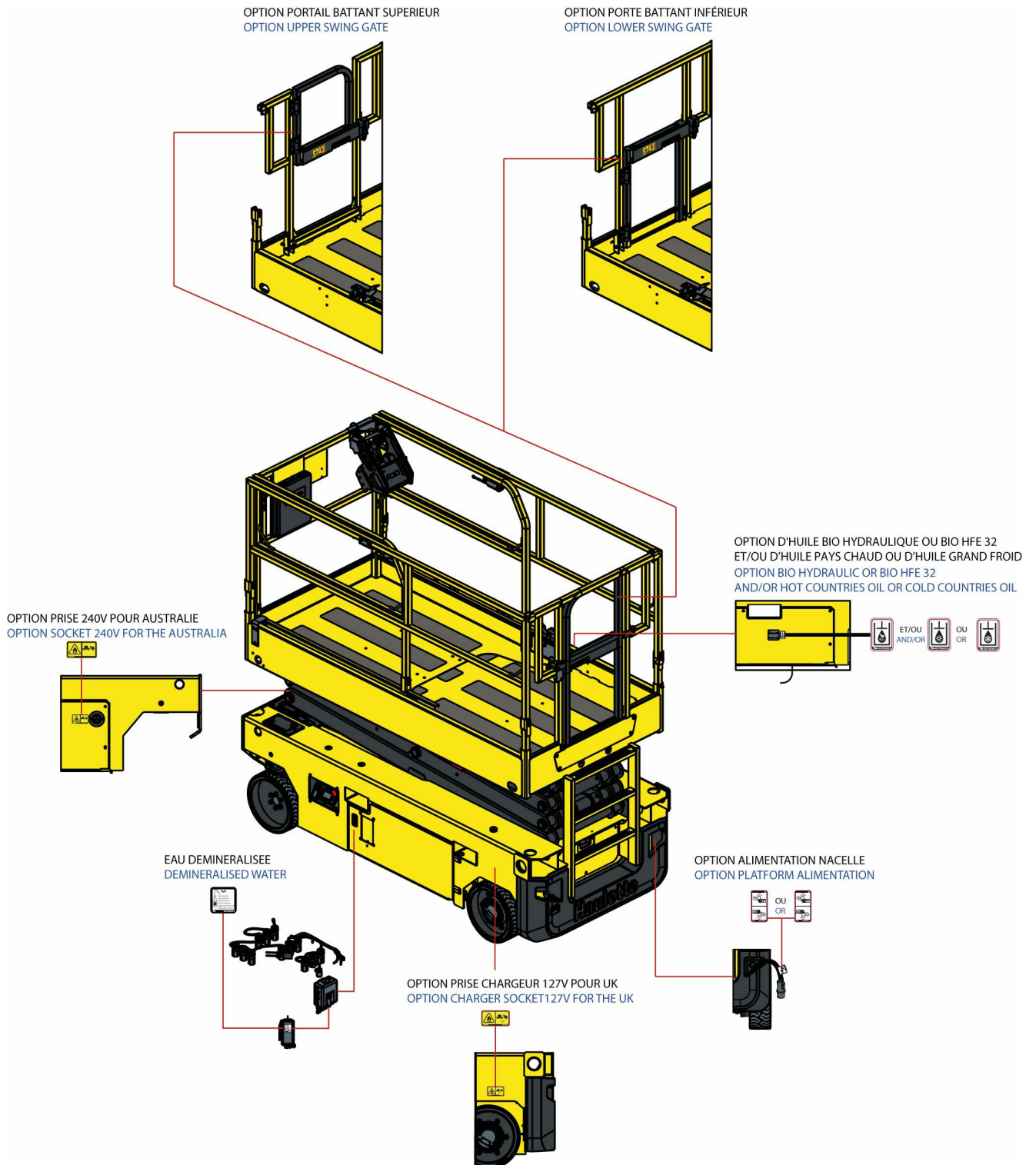

B - Familiarization

CE, UKCA, AS and EAC standards-COMPACT 10 AE - COMPACT 12 AE - COMPACT 14 AE

Marking	Description	Quantity	
1	Height of the floor and load	2	For COMPACT 10 AE : 4001185790 For COMPACT 12 AE : 4001185800 For COMPACT 14 AE : 4001185810
2	Maximum Pressure per Tire - Floor Loading	4	For COMPACT 10 AE : 4001202550 For COMPACT 12 AE : 4001194970 For COMPACT 14 AE : 4001194970
3	Commercial name-Bright machine	2	For COMPACT 10 AE : 4001185930 For COMPACT 12 AE : 4001185950 For COMPACT 14 AE : 4001185970
3	Commercial name-Dark machine	2	For COMPACT 10 AE : 4001185940 For COMPACT 12 AE : 4001185960 For COMPACT 14 AE : 4001185980
4	Decal HAULOTTE®-Bright machine	2	4001072210
4	Decal HAULOTTE®-Dark machine	2	4001072220
6	Identification plate	1	For CE, UKCA and AS standards only : 4001243970 For Russia : 4000388680 For Ukraine : 4000054150
7	Rivet	4	2421803570
11	Lanyard attachment points	6	4001052020
12	Material risk-Yellow and black adhesive tape	2	4001052030
13	Hydraulic oil	1	4001052050
17	Risk of crushing	6	4001052070
19	Read the operation manual	2	4001052090
23	Driving direction	3	4001052110
24a	Danger of electrocution	1	For CE, UKCA and EAC standards only: 4001052120
24b	Danger of electrocution	2	For AS standard only: 4001052140
25	Risk of crushing-Closing drop rail	1	4001052150
28	Software version	1	4000504670
31	Brake release	1	4001052170
32	Anchorage point-Traction	4	4001052180

B - Familiarization

Marking	Description	Quantity	
34	Risk of electrocution-Water projection	3	4001052200
53	Emergency lowering-T-handle	1	4001052210
55	Risk of electrocution-Charger- 240 V	1	4001110960
56	Risk of electrocution-Charger- 127 V	1	4001110970
57	Position of the lift truck forks	6	4001052230
59	Scissors safety	2	4001052250
61	Risk of crushed feet	2	4001052260
65	Hazard-Battery	1	4001052270
68	Information-Transport height	1	For COMPACT 10 AE : 4001187100 For COMPACT 12 AE : 4001187110 For COMPACT 14 AE : 4001187120
69	Information-Battery isolation switch	1	4001052290
70	Information- AC MAINTENANCE-FREE MOTORS -Bright machine	1	4001053450
70	Information- AC MAINTENANCE-FREE MOTORS -Dark machine	1	4001053500
75	Information- ACTIV' ENERGY MANAGEMENT -Bright machine	1	4001053460
75	Information- ACTIV' ENERGY MANAGEMENT -Dark machine	1	4001053510
78	QR Code ( https://www.e-technical-information.com)	1	4001089310
94	Information-Folding guardrails	1	4001197660
Not illustrated	Compressed air option	1	4001052370
Not illustrated	Pipe holder option	1	4001194340
Not illustrated	Plate holder option	1	4001199540
			4001199550
Not illustrated	Centralized filling option	1	4001052340
Not illustrated	Plate holder optionHFE 32	1	4001052380
			4001052400
Not illustrated	Biodegradable hydraulic oil option-Cold country	1	4001052390
Not illustrated	Swing door option-Maximum	1	4001052080

B - Familiarization

Marking	Description	Quantity	
Not illustrated	Swing door option-Minimum	1	4001052080
Not illustrated	Power plug option	1	4001052350 / 4001052360
Not illustrated	Option 127 V charger socket	1	4001110970
Not illustrated	Option 240 V charger socket	1	4001110960
Not illustrated	Folding guardrails option	1	4001222350
			4001222360
			4001222370
			4001222380
			4001222390
			4001222400

B - Familiarization

ANSI and CSA standards-4001186870 - COMPACT 2032E AE - COMPACT 2632E AE

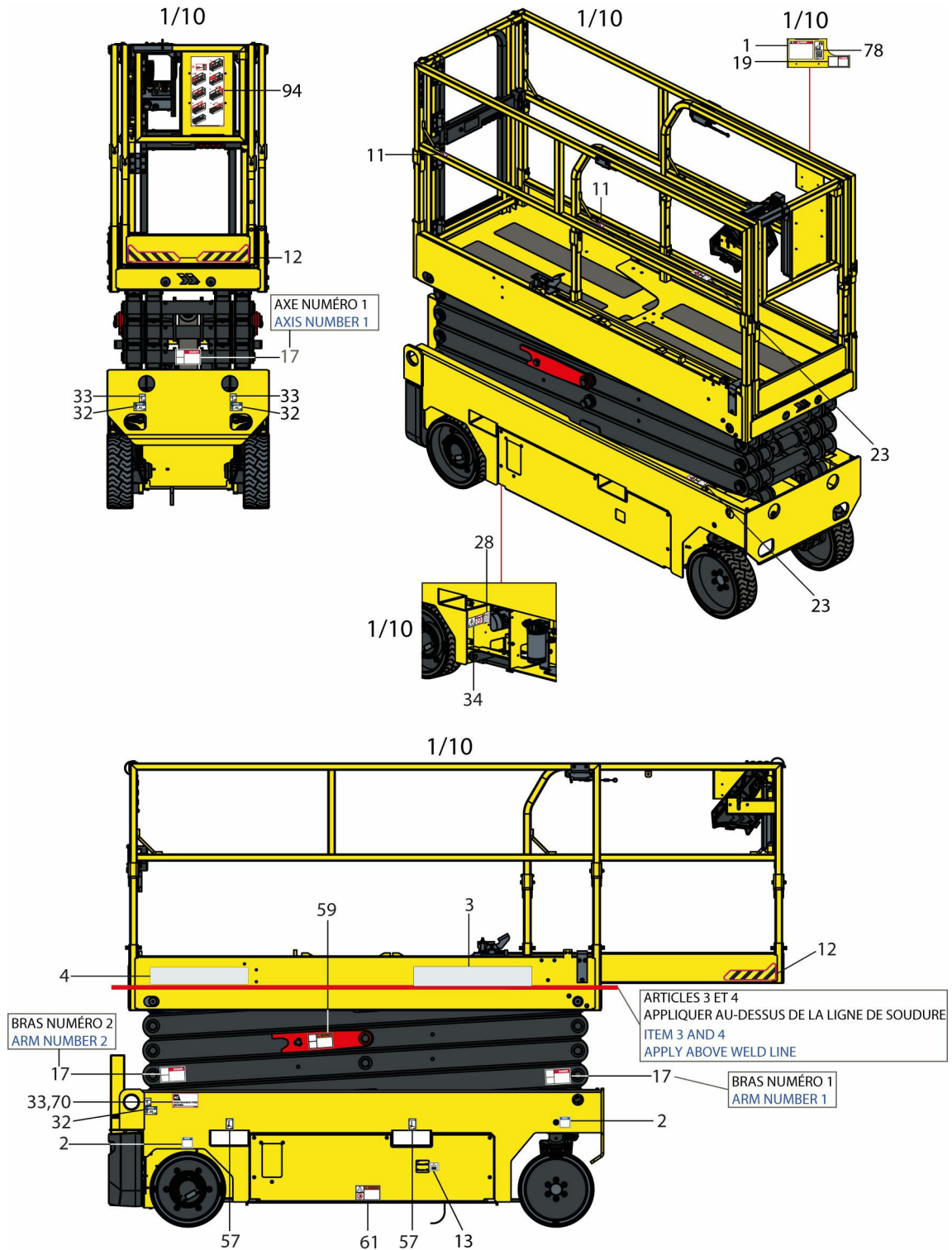

B - Familiarization

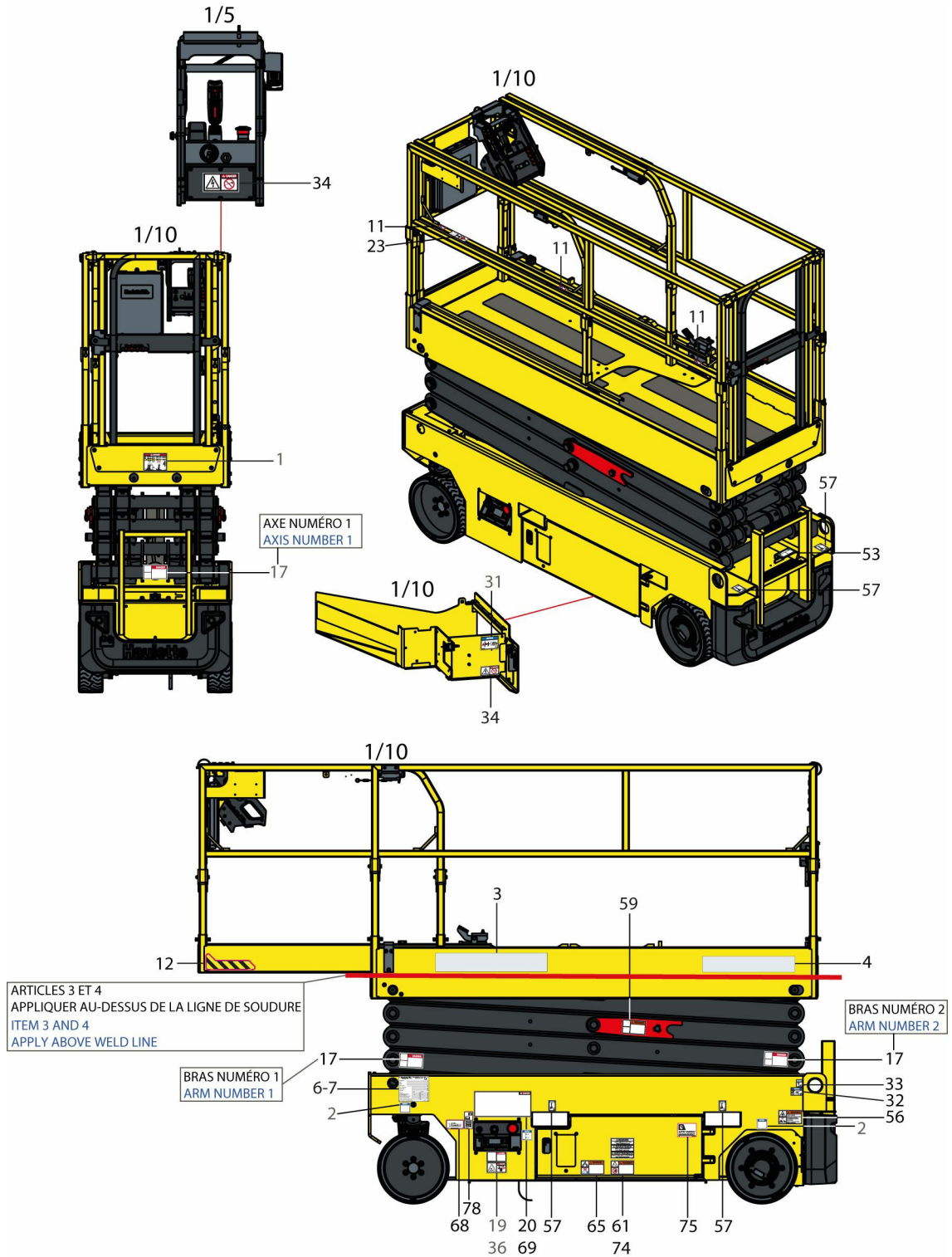

B - Familiarization

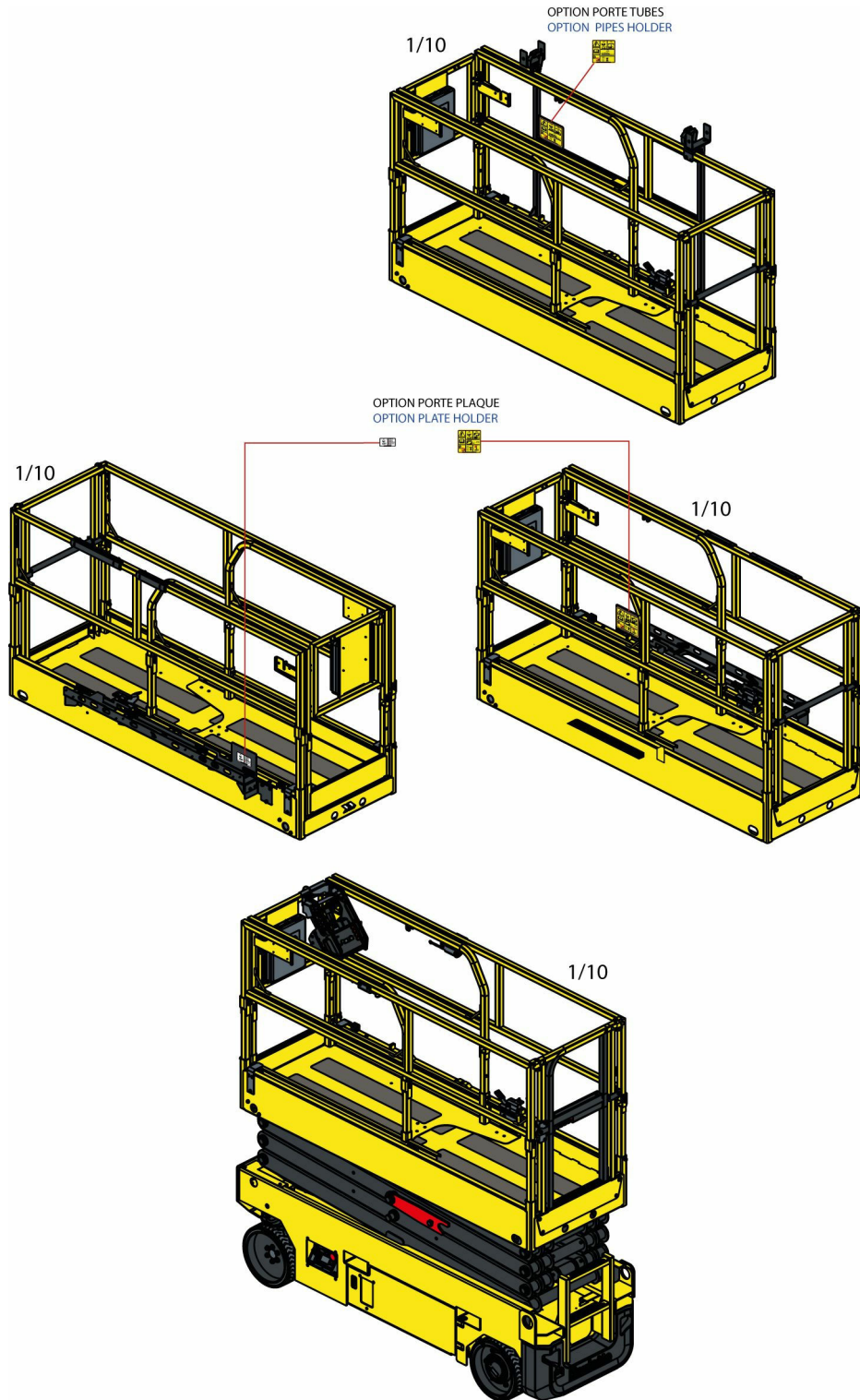

B - Familiarization

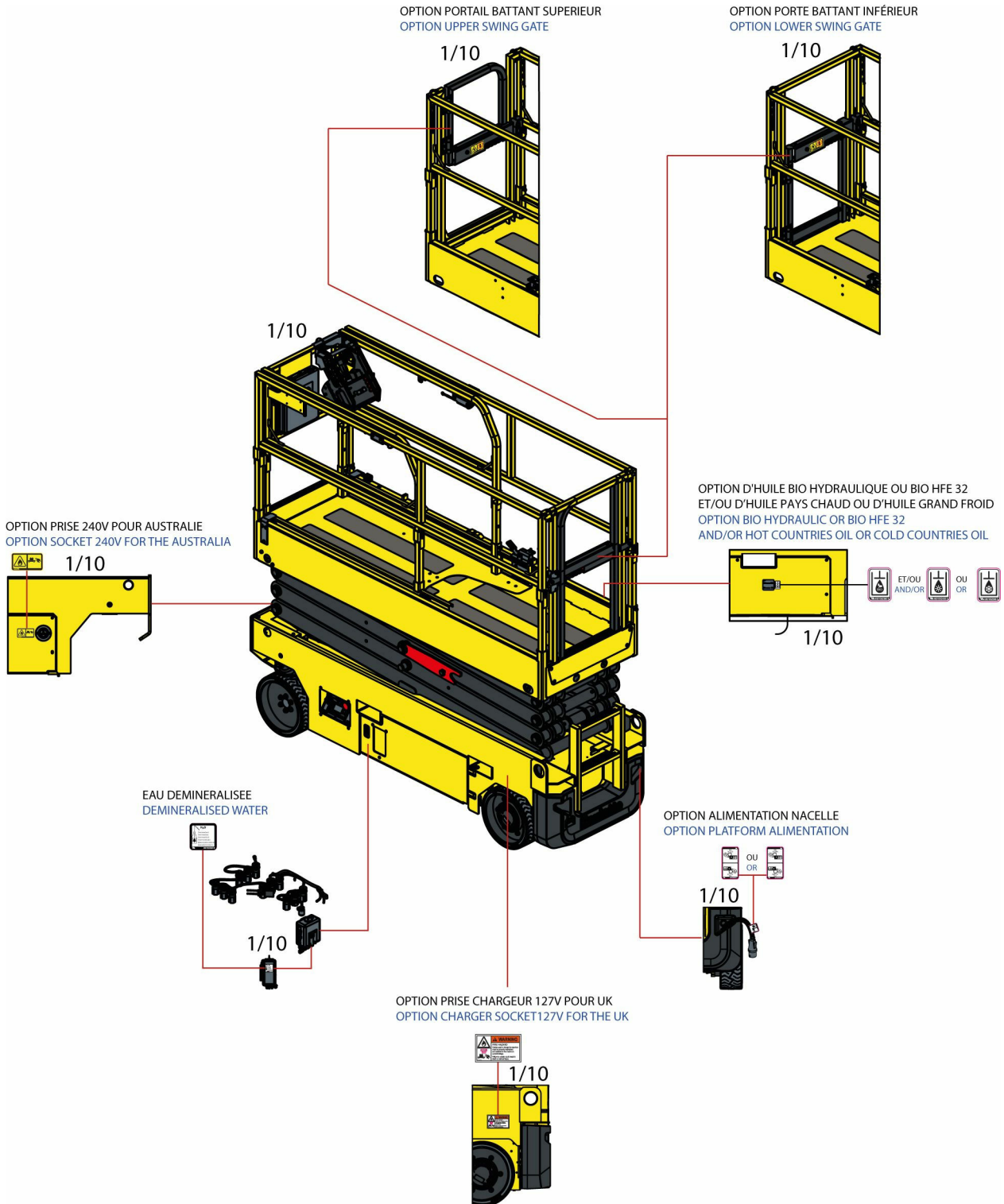

B - Familiarization

ANSI and CSA standards-COMPACT 2032E AE - COMPACT 2632E AE

Marking	Description	Quantity	
1	Height of the floor and load	2	For COMPACT 2032E AE : 4001185820 For COMPACT 2632E AE : 4001185830
2	Maximum Pressure per Tire - Floor Loading	4	4001194320
3	Commercial name-Bright machine	2	For COMPACT 2032E AE : 4001185990 For COMPACT 2632E AE : 4001186010
3	Commercial name-Dark machine	2	For COMPACT 2032E AE : 4001186000 For COMPACT 2632E AE : 4001186020
4	Decal HAULOTTE®-Bright machine	2	4001072210
4	Decal HAULOTTE®-Dark machine	2	4001072220
6	Identification plate	1	4000700150
7	Rivet	4	2421803570
11	Lanyard attachment points	5	4001052020
12	Material risk-Yellow and black adhesive tape	2	4001052030
13	Hydraulic oil	1	307P221080
17	Risk of crushing	6	In english : 4000130190 In french : 4000130200 In spanish : 4000130210
19	Read the operation manual	2	4000025140
20	Operation instructions	1	In english : 4000243670 In french : 4000243680 In spanish : 4000243690
23	Risk of crushing-Driving direction	3	4001052110
28	Software version	1	4000504670
31	Brake release	1	4000361570
32	Anchorage point-Traction	4	4000027310
33	Anchorage point-Lifting	4	4000027330
34	Risk of electrocution-Water projection	3	4000025130

B - Familiarization

Marking	Description	Quantity	
36	Emergency lowering-Platform	1	4000244340
53	Emergency lowering-T-handle	1	4000227200
56	Risk of electrocution-Charger- 127 V	1	4001134690
57	Position of the lift truck forks	6	3078143830
59	Scissors safety	2	In english : 4000024850 In french : 4000068070 In spanish : 4000086500
61	Risk of crushed feet	2	In english : 4000024780 In french : 4000067700 In spanish : 4000086480
65	Hazard-Battery	1	In english : 4000025030 In french : 4000068120 In spanish : 4000086550
68	Information-Transport height	1	For COMPACT 2032E AE : 4001187080 For COMPACT 2632E AE : 4001187090
69	Information-Battery isolation switch	1	4000420660
70	Information- AC MAINTENANCE-FREE MOTORS -Bright machine	1	4001053450
70	Information- AC MAINTENANCE-FREE MOTORS -Dark machine	1	4001053500
74	California warning- P65	1	4001026850
75	Information- ACTIV' ENERGY MANAGEMENT -Bright machine	1	4001053460
75	Information- ACTIV' ENERGY MANAGEMENT -Dark machine	1	4001053510
78	QR Code ( https://www.e-technical-information.com)	1	4001089310
94	Information-Folding guardrails	1	4001196420
Not illustrated	Compressed air option	1	4001052370
Not illustrated	Pipe holder option	1	4001194340
Not illustrated	Plate holder option	1	4001199540
			4001199550
Not illustrated	Centralized filling option	1	4001052340

B - Familiarization

Marking	Description	Quantity	
Not illustrated	Plate holder optionHFE 32	1	4001052380
			4001052400
Not illustrated	Biodegradable hydraulic oil option- Cold country	1	4001052390
Not illustrated	Swing door option-Maximum	1	4001052080
Not illustrated	Swing door option-Minimum	1	4001052080
Not illustrated	Power plug option	1	4001052350 / 4001052360
Not illustrated	Option 127 V charger socket	1	4001134690
Not illustrated	Folding guardrails option	1	4001222350
			4001222360
			4001222370
			4001222380
			4001222390
			4001222400

B - Familiarization

ANSI and CSA standards-4001188090 - COMPACT 2647E AE - COMPACT 3247E AE - COMPACT 3947E AE

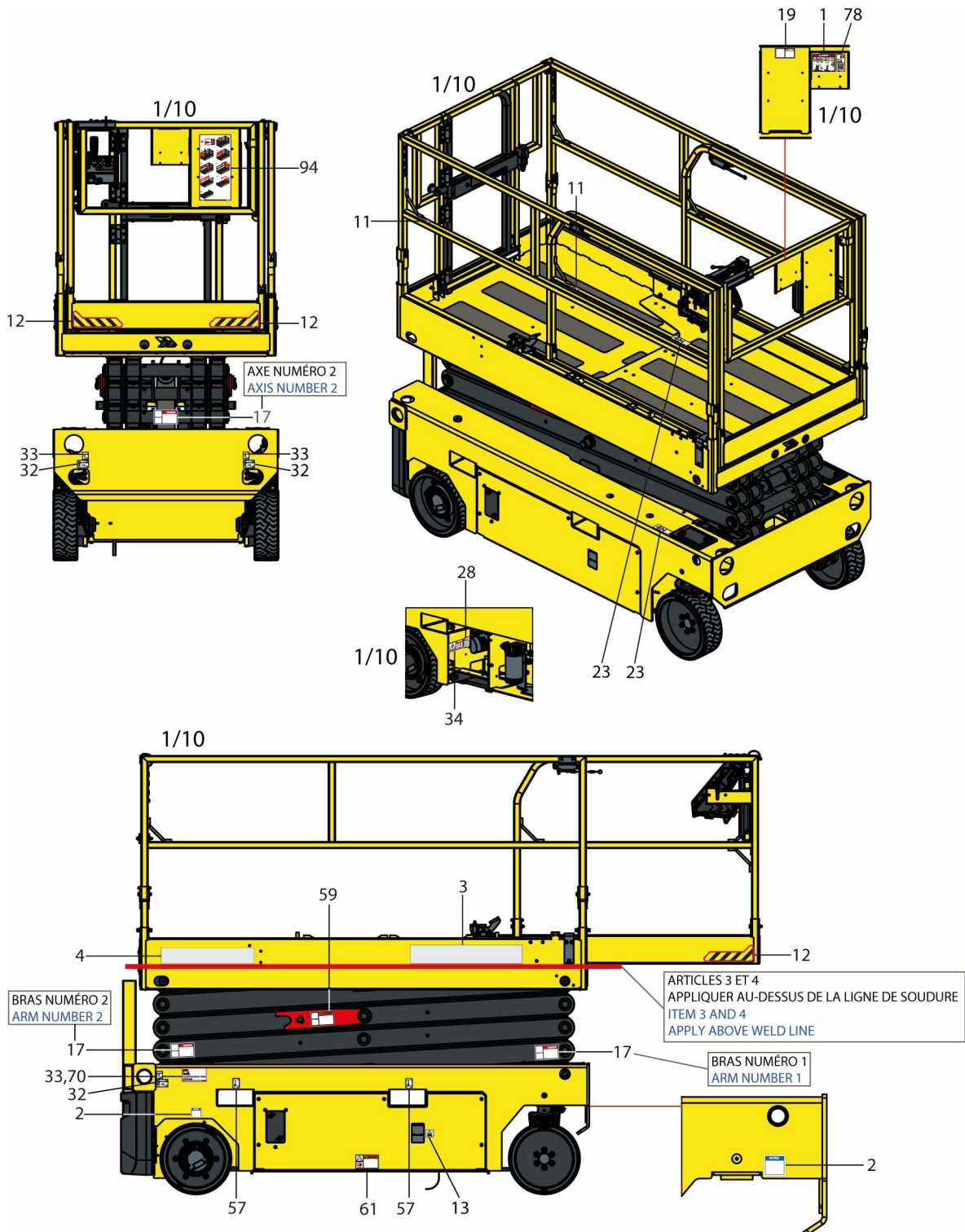

B - Familiarization

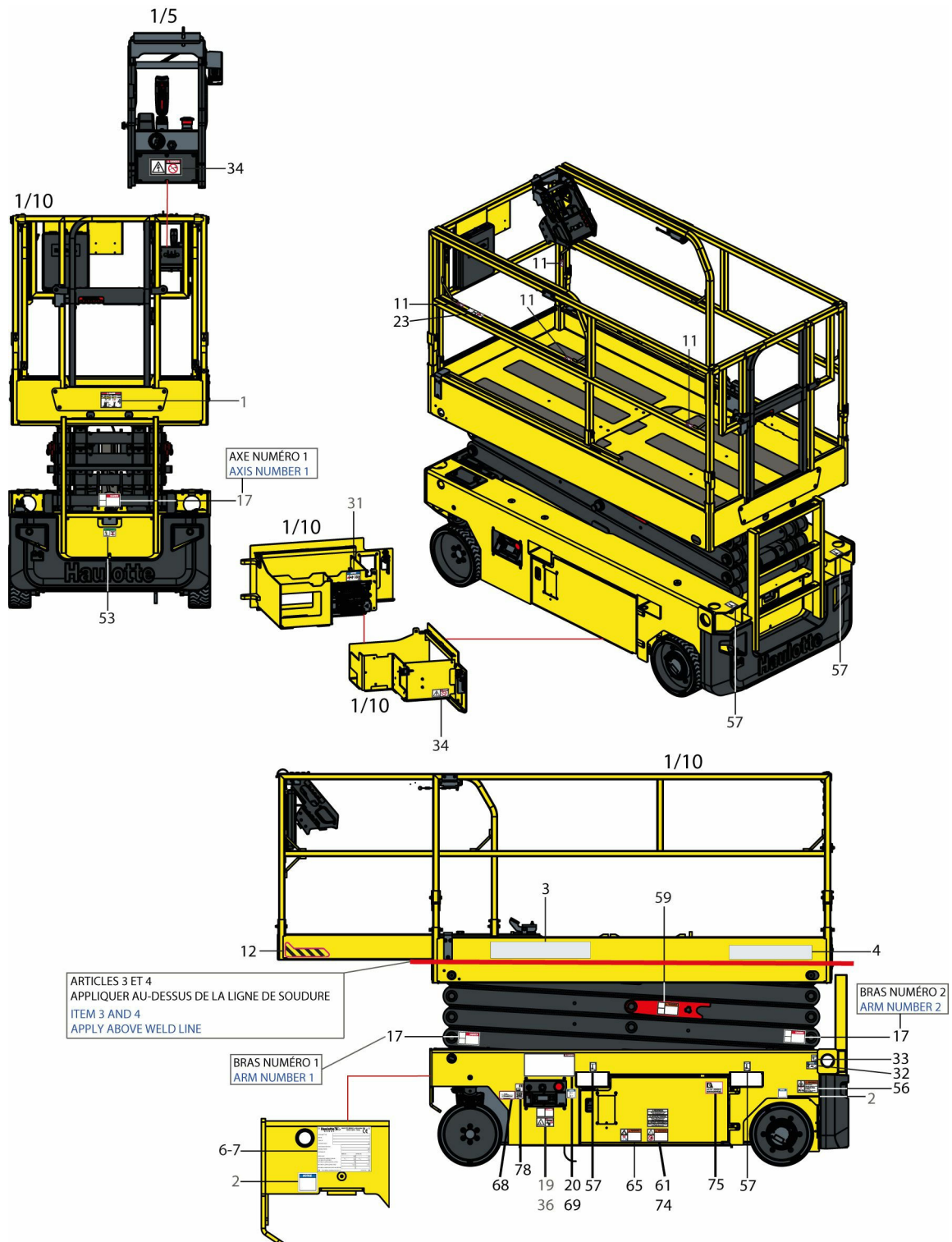

B - Familiarization

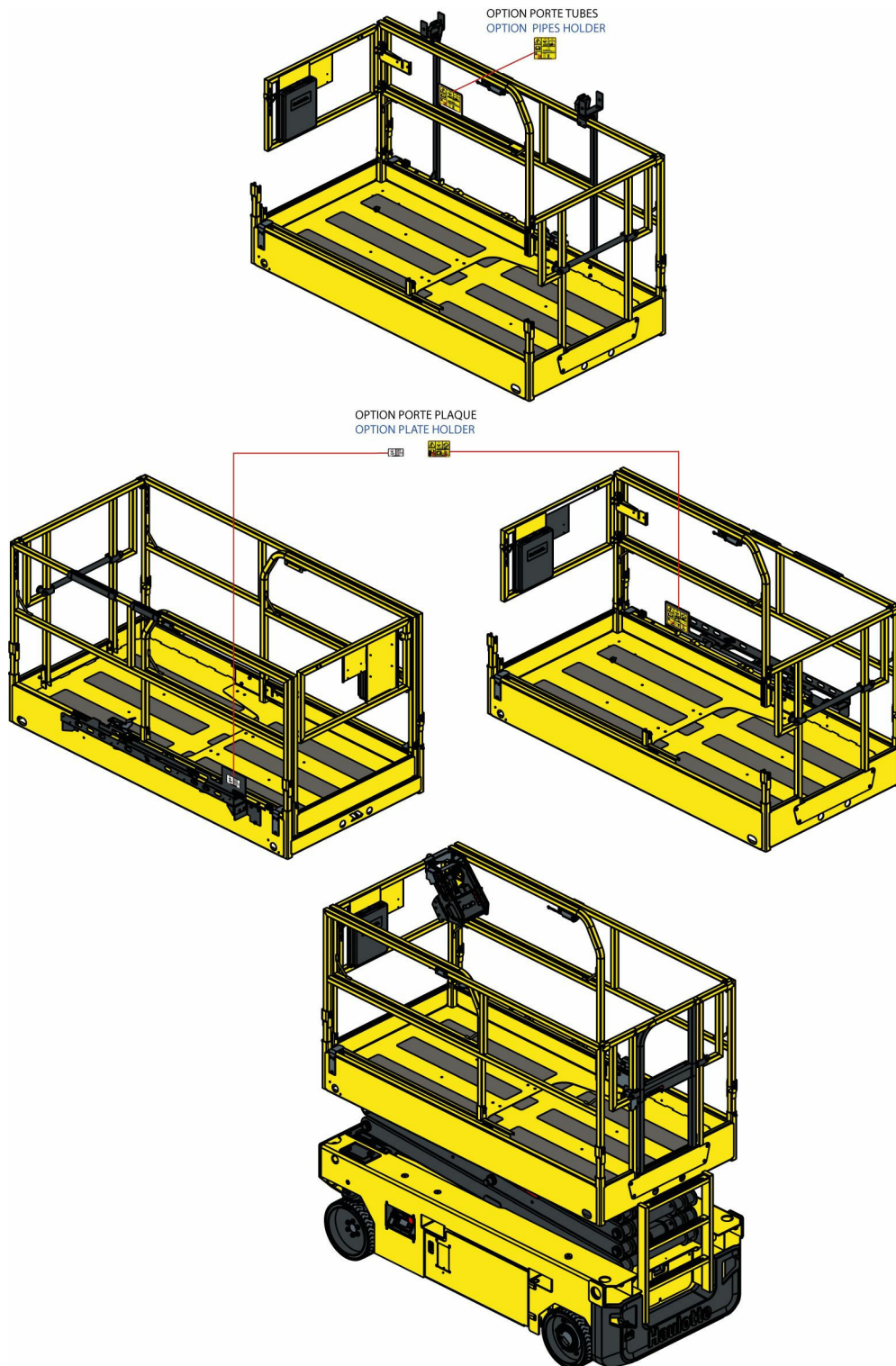

B - Familiarization

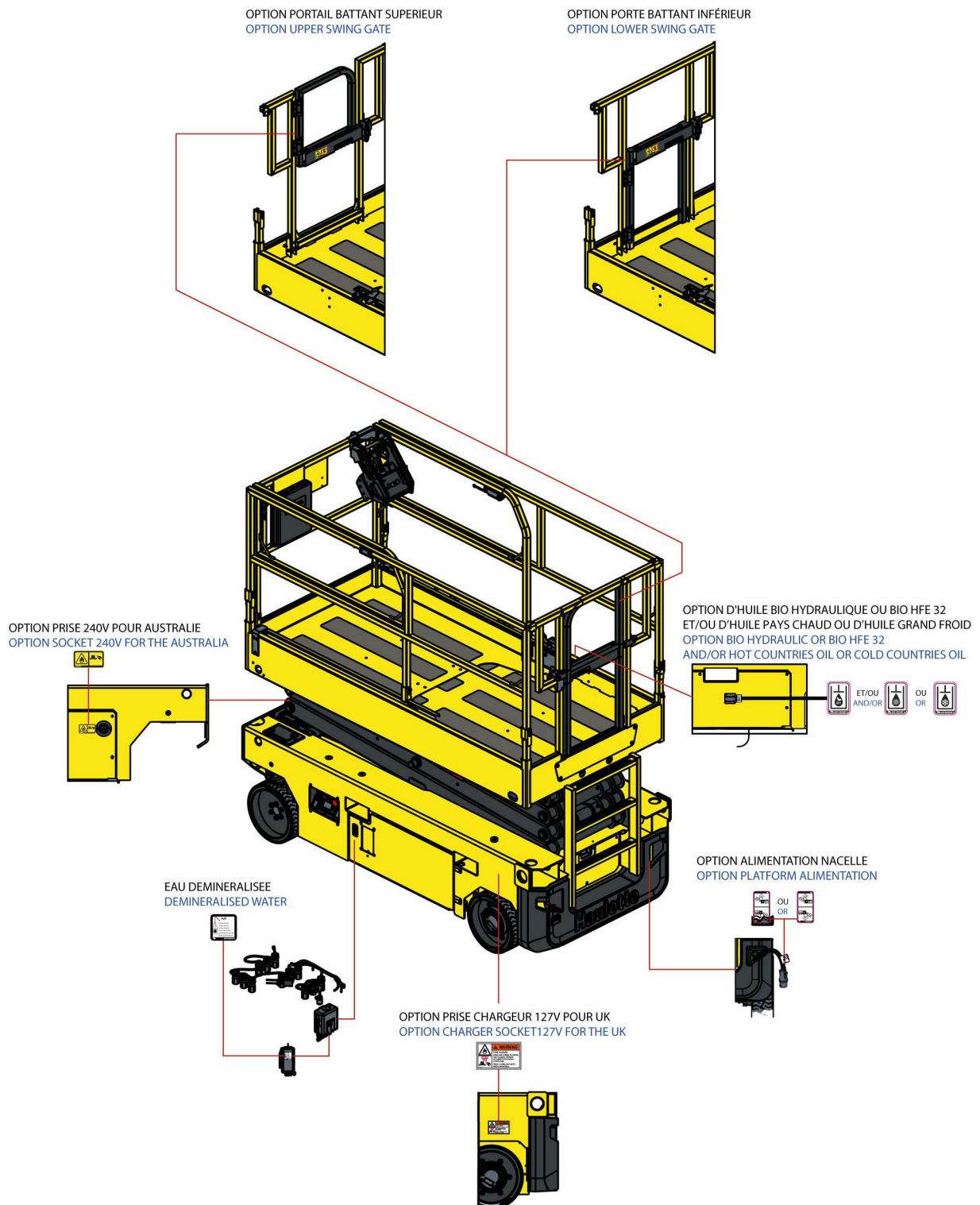

B - Familiarization

ANSI and CSA standards-COMPACT 2647E AE - COMPACT 3247E AE - COMPACT 3947E AE

Marking	Description	Quantity	
1	Height of the floor and load	2	For COMPACT 2647E AE : 4001185840 For COMPACT 3247E AE : 4001185850 For COMPACT 3947E AE : 4001185860
2	Maximum Pressure per Tire - Floor Loading	4	For COMPACT 2647E AE : 4001202550
2	Maximum Pressure per Tire - Floor Loading	4	For COMPACT 3247E AE : 4001194970 For COMPACT 3947E AE : 4001194970
3	Commercial name-Bright machine	2	For COMPACT 2647E AE : 4001186030 For COMPACT 3247E AE : 4001186050 For COMPACT 3947E AE : 4001186070
3	Commercial name-Dark machine	2	For COMPACT 2647E AE : 4001186040 For COMPACT 3247E AE : 4001186060 For COMPACT 3947E AE : 4001186080
4	Decal HAULOTTE®-Bright machine	2	4001072210
4	Decal HAULOTTE®-Dark machine	2	4001072220
6	Identification plate	1	4000700150
7	Rivet	4	2421803570
11	Lanyard attachment points	6	4001052020
12	Material risk-Yellow and black adhesive tape	2	4001052030
13	Hydraulic oil	1	307P221080
17	Risk of crushing	6	In english : 4000130190 In french : 4000130200 In spanish : 4000130210
19	Read the operation manual	2	4000025140

B - Familiarization

Marking	Description	Quantity	
20	Operation instructions	1	In english : 4000243670 In french : 4000243680 In spanish : 4000243690
23	Driving direction	1	4001052110
28	Software version	1	4000504670
31	Brake release	1	4000361570
32	Anchorage point-Traction	4	4000027310
33	Anchorage point-Lifting	4	4000027330
34	Risk of electrocution-Water projection	3	4000025130
36	Emergency lowering-Platform	1	4000244340
53	Emergency lowering-T-handle	1	4000227200
56	Risk of electrocution-Charger- 127 V	1	4001134690
57	Position of the lift truck forks	6	3078143830
59	Scissors safety	2	In english : 4000024850 In french : 4000068070 In spanish : 4000086500
61	Risk of crushed feet	2	In english : 4000024780 In french : 4000067700 In spanish : 4000086480
65	Hazard-Battery	1	In english : 4000025030 In french : 4000068120 In spanish : 4000086550
68	Information-Transport height	1	For COMPACT 2647E AE : 4001187100 For COMPACT 3247E AE : 4001187110 For COMPACT 3947E AE : 4001187120
69	Information-Battery isolation switch	1	4000420660
70	Information- AC MAINTENANCE-FREE MOTORS -Bright machine	1	4001053450
70	Information- AC MAINTENANCE-FREE MOTORS -Dark machine	1	4001053500
74	California warning- P65	1	4001026850

B - Familiarization

Marking	Description	Quantity	
75	Information- ACTIV' ENERGY MANAGEMENT -Bright machine	1	4001053460
75	Information- ACTIV' ENERGY MANAGEMENT -Dark machine	1	4001053510
78	QR Code ( https://www.e-technical-information.com)	2	4001089310
94	Information-Folding guardrails	1	4001197660
Not illustrated	Compressed air option	1	4001052370
Not illustrated	Pipe holder option	1	4001194340
Not illustrated	Plate holder option	1	4001199540
			4001199550
Not illustrated	Centralized filling option	1	4001052340
Not illustrated	Plate holder optionHFE 32	1	4001052380
			4001052400
Not illustrated	Biodegradable hydraulic oil option- Cold country	1	4001052390
Not illustrated	Swing door option-Maximum	1	4001052080
Not illustrated	Swing door option-Minimum	1	4001052080
Not illustrated	Power plug option	1	4001052350 / 4001052360
Not illustrated	Option 127 V charger socket	1	4001134690
Not illustrated	Folding guardrails option	1	4001222350
			4001222360
			4001222370
			4001222380
			4001222390
			4001222400

C - Pre-operation inspection

1	Recommendations.....	3
2	Working area assessment.....	4
3	Inspection and Functional test.....	5
3.1	Daily inspection.....	5
4	Safety functional checks.....	8
4.1	Lowering for repairs.....	8
4.2	Emergency push buttons	9
4.2.1	Ground control box.....	9
4.2.2	Platform control box.....	9
4.3	Activation of controls.....	9
4.3.1	Ground control box.....	9
4.3.2	Platform control box.....	10
4.3.3	Foot Switch.....	10
4.4	Buzzers test.....	10
4.5	Indicator light test.....	11
4.6	Travel speed limitation.....	11
4.7	Slope warning device.....	12
4.8	Machine braking.....	12
4.9	Pothole protection system (Pothole protection)	13
4.10	Anti-crush system when lowering.....	14

C - Pre-operation inspection

1 Recommendations

The owner, the site manager, the supervisor and the operator are all responsible to ensure the machine is fit for the work it is to perform; i.e. that the machine is suitable to carry out the work in complete safety and in compliance with this Operator's Manual. All managers who are responsible for persons operating the machine must be familiar with the local regulations currently applicable in the country of use and ensure that they are adhered to.

Before using the machine, read the previous chapters in this manual. Ensure that you have understood the following points :

- Safety precautions.
- Operator's responsibilities.
- Conditions and the operating principles of the machine.

C - Pre-operation inspection

2 Working area assessment

Before carrying out any operations, ensure that the machine corresponds to the work to be done and the working environment :

- Carry out a thorough inspection of the site to identify any potential risks within the work zone.
- Take the necessary precautions to avoid collisions with other machinery or people within the work area.
- Mark out the work area.
- **Ensure that :**
 - The weather conditions (wind, rain, etc.) allowing the machine to be used.
 - The ground withstands the weight of the machine and has not been affected by the poor weather conditions.
- Check that the authorisations to work with the machine on the site in question have been obtained (.g. chemical product factories).
- Define a rescue plan for all the risks, including the risk of falls and crushing.

C - Pre-operation inspection

3 Inspection and Functional test

3.1 Daily inspection

Each day before the beginning of a new work session and with each change of operator, the machine must be subjected to a visual inspection and a complete functional test.



- Never use a defective or a malfunctioning aerial work platform.
- If any item on the check list is marked "No" during the inspection; machine must be tagged and placed out of service.
- Do not operate the machine until all identified items are corrected and it has been declared safe for operation.

In case of loose fasteners, refer to torque table value in maintenance book.

In case of leaks, replace the damaged part before use.

In case of structural part deformation (cracks, broken weld, paint chips) replace the part before use.



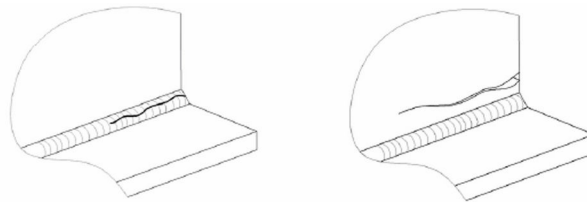





Sample of broken welds



We recommend these forms to be completed daily and stored to assist with your maintenance schedule.

Each action is depicted in the daily inspection sheet using the following symbols.











Use the detailed program below.

	Oil change ⁽¹⁾		Lubrication-Lubrication ⁽¹⁾		Tightening ⁽¹⁾
	Levelling ⁽¹⁾		Systematic replacement ⁽¹⁾		Functional adjustments / Checks / Cleaning ⁽¹⁾
	Visual inspection		To check by test		

















Serial number : Hours of operation : HAULOTTE Services® contract reference : Intervention record number : Date : Name :	Model : Signature :
--	------------------------

⁽¹⁾ Refer to the Service Manual

C - Pre-operation inspection

	Daily	OK	NOK	Corrected	Comments
Chassis assembly : Wheel, reducer, steering, wheel pivot					
Check state of tires/tyres and inflations (wear, fastening, etc)					
Ensure the cleanliness and absence of obstacles in the rails of the chassis and work platform					
Batteries					
Check the condition of the battery					
Check the locking operation of the battery casing					
Hydraulic : oils, filters and hoses					
Check the hydraulic oil level (Top up the oil if necessary ; Machine stowed)					
Check the hoses, blocks and pumps, fittings, cylinders and the tank for the absence of leaks, deformations and damage					
Platform					
Ensure that the sliding door or bar automatically returns to the closed and locked position					
Check that the harness anchor points are not cracked or damaged					
Clean the platform extension					
Check the locking pins and correct placement of the guardrails					

C - Pre-operation inspection

	Daily	OK	NOK	Corrected	Comments
General					
Check for the presence, cleanliness and readability of the manufacturer's plates, security labels, user manual and maintenance manual					
Check the cleanliness and readability of the control box					
Check the condition of electrical harnesses, cables and connectors					
Check for the absence of abnormal noise and jerky movements					
Check for the absence of visible deterioration and damage					
Check for the absence of cracks, broken welds and chipped paintwork on the structure					
Check for the absence of missing or loose screws and bolts					
Check for the absence of deformation, cracking and breakage of axis stops, bushing and axes					
Check for the absence of foreign bodies in joints and sliding parts					
Safety devices ( C 4 - Safety functional checks)					
Test the operation of the upper and lower control boxes: manipulators, switches, buttons, horn, emergency stops, screens and lights					
Check the absence of visual and audible alarms					
Test the operation of the tilt system					
Test the operation of the emergency lowering system					
Test the operation of the load control system - Calibrate if necessary					

C - Pre-operation inspection

4 Safety functional checks

To protect the user and the machine, safety systems prevent the movement of the machine beyond its operating limits. These safety systems when activated immobilize the machine and prevent further movement.

The operator must be familiar with this technology and understand that is not a malfunction but an indication that the machine has reached an operation limit.

Aerial Work platforms are equipped with two control boxes which allow operators to safely use the machine. An auxiliary device (T-handle) is available on the chassis to assist with the emergency lowering of the machine.

The following checks describe the operation of the machine and the specific controls required.



In the event of a malfunction or inconclusive test, do not use the machine and contact HAULOTTE Services®.



For the location and description of these controls : refer to section B 3.2 and D 2 - Ground control box and B 3.3 and D 3 - Platform control box.

4.1 Lowering for repairs

Ground control box

Step	Action
1	Lift the platform approximately 1 m(3 ft3 in).
2	Activate and hold the T-handle (C107) to lower the work platform.
3	Release the T-handle (C107) and ensure that the platform stops.
4	Fold the platform until it is in its transport configuration.

Pull T-handle for emergency lowering



N.B.-:PULLING ON TO THE T-HANDLE, IMMEDIATELY ACTIVATES THE EMERGENCY LOWERING OF THE PLATFORM.



ALWAYS keep personnel and obstructions clear of the aerial work platform that might block the lowering.

C - Pre-operation inspection

4.2 Emergency push buttons

4.2.1 Ground control box

Step	Action
1	Pull both E-Stop buttons; (15) at ground box and (46) at platform box.
2	On the keypad (C188), enter the correct access code, press ENTER button to energize the ground control box. The green indicators (LED 1, LED 4) on the keypad lights up and Activ'Screen switch on.
3	Press the emergency stop pushbutton (15).
4	Check no movements are functional.

4.2.2 Platform control box

Step	Action
1	Pull both E-Stop buttons; (15) at ground box and (46) at platform box.
2	On the keypad C188, enter the correct access code, press ENTER button, the ground control box is energized by default, then press PLTFM button to energize the platform control box. The green indicators (LED 2, LED 4) on the keypad lights up and Activ'Screen switch on.
3	Press the emergency stop pushbutton (46).
4	Check no movements are functional.

4.3 Activation of controls

The enable foot pedal (enable switch) must be activated to allow any movement.

The "Enable Switch" system depends on the machine configuration and will consist of one of the following

- Joystick trigger (123) on the platform control box.
- Foot pedal (enable switch) in the platform (Optional) (245).
- Enable switch on the ACTIV'Screen (9) on ground control box.

4.3.1 Ground control box

Step	Action
1	Pull both E-Stop buttons; (15) at ground box and (46) at platform box.
2	On the keypad (C188), enter the correct access code, press ENTER button to energize the ground control box. The green indicators (LED 1, LED 4) on the keypad lights up and Activ'Screen switch on.
3	Press and hold the enable switch (9) and the 'raise platform' command (1) to raise the platform. Release the enable switch (9); movement stops.
4	Press and hold the enable switch (9) and the 'lower platform' command (2) to lower the platform. Release the enable switch (9); movement stops.

C - Pre-operation inspection

4.3.2 Platform control box

Step	Action
1	Pull both E-Stop buttons; (15) at ground box and (46) at platform box.
2	On the keypad (C188), enter the correct access code, press ENTER button, the ground control box is energized by default, then press PLTFM button to energize the platform control box. The green indicators (LED 2, LED 4) on the keypad lights up and Activ'Screen switch on.
3	Test the drive and steer controls.
4	Release the joystick trigger (123); movement stops.
5	Test the elevation movements (raise and lower).
6	Release the joystick trigger (123); movement stops.

4.3.3 Foot Switch

Step	Action
1	Pull both E-Stop buttons; (15) at ground box and (46) at platform box.
2	On the keypad (C188), enter the correct access code, press ENTER button, the ground control box is energized by default, then press PLTFM button to energize the platform control box. The green indicators (LED 2, LED 4) on the keypad lights up and Activ'Screen switch on.
3	Press and hold the Foot Switch down to confirm the movement.
4	Release the activation pedal; movement stops.

4.4 Buzzers test



An audible signal is heard when the machine is switched on.

Platform control box

Step	Action
1	Pull both E-Stop buttons; (15) at ground box and (46) at platform box.
2	On the keypad (C188), enter the correct access code, press ENTER button, the ground control box is energized by default, then press PLTFM button to energize the platform control box. An audible signal (beep) sounds.
3	Push the horn selector (43) to the right to sound the horn. The horn stops when the selector switch is released.

C - Pre-operation inspection

4.5 Indicator light test



An audible signal is heard when the machine is switched on.

Ground control box

Step	Action
1	Pull both E-Stop buttons; (15) at ground box and (46) at platform box.
2	On the keypad (C188), enter the correct access code, press ENTER button to energize the ground control box.
3	Check that the indicator lights (LED 1, LED 4, 7 - 8) and Activ'Screen illuminate on start-up.

Platform control box

Step	Action
1	Pull both E-Stop buttons; (15) at ground box and (46) at platform box.
2	Press the emergency stop pushbutton (46) on the platform control box.
3	On the keypad (C188), enter the correct access code, press ENTER button, the ground control box is energized by default, then press PLTFM button to energize the platform control box.
4	Pull the E-Stop button (46) at the platform control box.
5	Check that the indicator lights (LED 2, LED 4, 91 - 85 - 30 - 27 - 110 - 111) illuminate on start-up.

4.6 Travel speed limitation

All driving speeds are authorised when the machine is folded, (machine in transport position).

The machine automatically adapts its speed to the ground (slope, ramp) or elevation conditions.

Only micro speed is authorized in elevation.

Platform control box

Step	Action
1	From the platform control box, ensure that the high and low drive speeds are operational.
2	Raise the work platform to a height slightly higher than the micro speed activation height ( B 3.1 - Technical specifications) .
3	Ensure that the high and low drive speeds are not authorized.

C - Pre-operation inspection

4.7 Slope warning device

From each control box, a buzzer alerts the operator that the machine is not folded/stowed and is positioned on a slope exceeding the slope allowed.

N.B.-:THE SLOPE SENSOR IS ONLY ACTIVE WHEN THE PLATFORM IS NOT IN THE STOWED POSITION.

When machine is on a slope greater than the rated slope, with extending structure out of the stowed position :

- The DRIVE and LIFTING (RAISING) commands are deactivated.

The lowering speed is reduced.

In this case, fully lower the platform and reposition the machine on level ground before raising the platform again.



To check the tilt sensor at ground level, perform the following steps :

Platform control box

Step	Action
1	Put the machine in stowed position.
2	Position the machine on an incline that is greater than the maximum permitted incline ( B 3 - Technical specifications) .
3	Check that the tilt indicator is on (27).
4	Raise the platform until it reaches automatic cut-out (< 3,50 m (11 ft 6 in)).
5	Buzzers at ground and platform will beep.

4.8 Machine braking

Platform control box

Step	Action
1	Pull both E-Stop buttons; (15) at ground box and (46) at platform box.
2	On the keypad (C188), enter the correct access code, press ENTER button, the ground control box is energized by default, then press PLTFM button to energize the platform control box. The green indicators (LED 2, LED 4) on the keypad lights up.
3	Select the low drive speed (45)  , then activate the drive joystick (108) and the joystick trigger (123).
4	Press the emergency pushbutton (46) on the platform control box. Ensure that the machine stops quickly and does not drift.  In this configuration, stopping the machine is brutal.

C - Pre-operation inspection

4.9 Pothole protection system (Pothole protection)

The machine is equipped with a system to prevent overturning when moving - platform raised - in the event of a sudden change in the driving surface level (step, pothole, etc). Located under the chassis, this device deploys automatically before the work platform leaves its transport position (extending structure folded).

Visually check that the system has no damage.

Verify absence of any oil leaks.



The tests below are likely to cause the machine to move. Position the machine on a flat ground, stabilized and in a released environment. Mark out the work area.



Ensure that there is no-one near the machine.

Platform control box

Step	Action
1	Pull both E-Stop buttons; (15) at ground box and (46) at platform box.
2	On the keypad (C188), enter the correct access code, press ENTER button, the ground control box is energized by default, then press PLTFM button to energize the platform control box. The green indicators (LED 2, LED 4) on the keypad lights up.
3	Place a chock approximately 5 cm under one of the potholes.
4	Set the movement selector (112) to platform elevation/lowering.
5	Push the movement joystick (108) upwards and press and hold the joystick trigger (123) to raise the work platform to a level higher than the micro speed activation height :  B 3 - Technical specifications - Activation height of the micro speed.
6	Position the movement selector (112) to drive.
7	Gently push the movement joystick (108) downwards and press and hold the joystick trigger (123). The machine must not move. Movement is not authorized.
8	Set the movement selector (112) to platform elevation/lowering.
9	Push the movement joystick (108) downwards and press and hold the joystick trigger (123) to fold the platform.
10	Stow the machine completely.
11	Position the movement selector (112) to drive.
12	Gently push the movement joystick (108) downwards and press and hold the joystick trigger (123) for 3s seconds to fold the potholes.
13	Remove the chock.

C - Pre-operation inspection

4.10 Anti-crush system when lowering

The lowering movement of the platform is automatically stopped at the position where the vertical distance between the outer ends of the scissors could lead to a risk of finger crushing or shearing.





Ensure that there is no-one near the machine.



Ensure that no-one is standing under the platform and scissor arms.

Platform control box

Step	Action
1	Pull both E-Stop buttons; (15) at ground box and (46) at platform box.
2	On the keypad (C188), enter the correct access code, press ENTER button, the ground control box is energized by default, then press PLTFM button to energize the platform control box. The green indicators (LED 2, LED 4) on the keypad lights up.
3	Set the movement selector (112) to platform elevation/lowering.
4	Push the movement joystick (108) upwards and press and hold the joystick trigger (123) to raise the work platform to a level higher than the micro speed activation height :  B 3 - Technical specifications - Activation height of the micro speed.
5	 Push and hold the movement joystick (123) downwards and press and hold the joystick trigger to lower the work platform. Lowering is automatically interrupted. Release the joystick (108) and wait 3s. During timeout, ensure that no-one is standing in the immediate vicinity of the platform and scissor arms.
6	Push and hold the movement joystick (108) downwards and press and hold the joystick trigger (123). The lowering movement resumes at reduced speed, accompanied by an audible signal and flashing light until folding is complete (transport position).

D - Operation instructions

1	Operation.....	3
1.1	Introduction.....	3
1.2	Operation from the ground control box.....	3
1.3	Operation from the platform control box.....	4
2	Ground control box.....	5
2.1	To start and stop the machine.....	5
2.2	Movement control.....	5
2.3	Additional controls from the ground control box.....	5
3	Platform control box.....	6
3.1	To start and stop the machine.....	6
3.2	Drive and steer control.....	6
3.3	Elevation controls.....	6
3.4	Additional controls.....	7
4	Rescue and emergency procedures.....	8
4.1	In case of power loss.....	8
4.2	To rescue operator in platform.....	8
5	Transportation.....	9
5.1	Transport configuration.....	9
5.2	Folding guardrails.....	9
5.2.1	Description.....	9
5.2.2	Safety precautions.....	9
5.2.3	Guardrail folding procedure.....	10
5.2.4	Specific decals	14
5.2.5	Raising guardrails to working position.....	15
5.3	Machine stowage for transport.....	15
5.4	Unloading.....	16
5.5	Towing or winching (Slope crossing aid)	17
5.5.1	Electric brake release.....	17
5.6	Storage.....	18
5.7	Loading by ramp.....	18
5.8	Unloading by ramp.....	19
5.9	Lifting operation.....	19
5.9.1	Procedure for the use of slings COMPACT 8N AE (COMPACT 2032E AE) - COMPACT 10N AE (COMPACT 2632E AE).....	20
5.9.2	Procedure for the use of slings COMPACT 10 AE (COMPACT 2647E AE) - COMPACT 12 AE (COMPACT 3247E AE) - COMPACT 14 AE (COMPACT 3947E AE).....	23
5.10	Loading and unloading with forklift.....	26
6	Cold Weather Recommendations.....	27
6.1	Hydraulic oil.....	27
7	Battery care and maintenance.....	28
7.1	Battery recharge.....	28
7.1.1	On-board charger.....	28
7.1.2	Battery charging.....	29
7.1.3	Fault codes.....	31
7.2	Battery care and maintenance.....	31
7.2.1	Manual centralized battery filling (Optional)	32
7.2.2	Automatic battery filling (Optional)	34
7.2.3	Desulfation charge.....	34
7.3	Optimise battery life.....	35

D - Operation instructions

1 Operation

1.1 Introduction

Only trained and authorized personnel shall be permitted to operate this aerial work platform.

Prior to operation :

- Read, understand and obey all instructions and safety precautions in this manual and attached to the aerial work platform.
- Read, understand and obey all local regulations.
- Become familiar with the proper use of all controls and emergency systems.

1.2 Operation from the ground control box

- Turning ON and OFF of the machine is performed with the keypad (C188).
- Enter the correct access code and press ENTER button to start, ground control box is selected by default ((LED 1, LED 4) are green).
- Activation of the platform control box is done by pressing PLTFM button.
- The ground control box is energized and is active ONLY when :
 - The emergency stop on the ground control box is not pushed in.
 - The machine is switched on.
- An E-stop button at each control box stops all movements when pressed in (deactivated).

N.B.-:AN E-STOP BUTTON PRESSED IN DOES NOT TURN OFF THE MAIN POWER SUPPLY TO THE MACHINE.

- An enable switch (9) must be activated and maintained to authorise movement. If Enable Switch (9) is kept engaged without selecting a function movement for more than 8 s; Enable Switch is automatically de-activated.
- If the enable switch (9) is released during movement, the movement will stop. The movement will stop gradually. If the Enable Switch system is re-pressed, the movement doesn't restart. It could restart only when the selected function switch/joystick is released to neutral position.
- All switches and joystick operating a movement, return automatically to neutral when released.
- The ground control box is designed for maintenance and emergency rescue operations only. Refer to  D 4.2 To rescue operator in platform.
- The status of the switches is tested automatically when the machine is switched on, and checked at every starting. A switch will be active only after it has been detected to be in neutral position. The following switches are not controlled :
 - Beacon light (if fitted)

A buzzer beeps in the following conditions :

- Overload.
- Machine elevated on a slope greater than the rated slope.
- Movement buzzer option.
- Drive buzzer option.
- Extreme temperature option.
- Brake is released.
- Lowering in the idle zone ( C 4.10 - Anti-crush system when lowering)

Visual warnings (warning lights, display, etc.)

- All indicators are checked when the machine is powered ON.

D - Operation instructions

1.3 Operation from the platform control box

- The platform control box can only be used if :
 - The E-stop buttons on both ground and platform control boxes are not pressed in.
 - Platform control box selected from the keypad.
- A faulty joystick or switch is not taken into account to control a movement. If this fault disappears, the movement is authorised again.
- An E-Stop button is present at each control box. When pushed in, it stops all functions movements.
- An enable switch (123) must be activated to authorise a movement. If an enable command is triggered for more than 8 seconds with no movement selected, the enable command must be released (reset) before another movement can be started.
- The release of the enable command (123) or the foot pedal switch in the basket (245) while performing a movement interrupts the current movement. The movement will stop gradually. It could restart only when the selected function switch/joystick is released to neutral position.
- All switches and joystick operating a movement, return automatically to neutral when released.
- The status of the switches and joysticks is tested automatically when the machine is switched on. A switch or joystick will be active only after it has been detected in neutral position. The following switches are not controlled :
 - Driving speed.

A buzzer beeps in the following conditions :

- Overload.
- Machine elevated on a slope greater than the rated slope.
- Extreme temperature option.
- Brake is released.
- Lowering in the idle zone ( C 4.10 - Anti-crush system when lowering)

Indicators - All the indicators are tested :

- When the machine is switched on.



While driving on a slope :

- Always orientate the machine in the direction of the slope.
- Stow the machine completely.
- Do not travel down slopes in high speed.
- Do not drive fast in narrow or cluttered areas. Keep speed under control while making turns or sharp bends.

D - Operation instructions

2 Ground control box

2.1 To start and stop the machine

- Ensure that the E-Stop buttons (15) and (46) at the ground and platform control boxes are pulled out.
- On the keypad (C188), enter the correct access code, press ENTER button to energize the ground control box.

To shut-down the machine from the keypad :

- Press the OFF button to turn off power to the machine.
- Power supply is now switched off.

N.B.-:THIS OPERATION TURNS OFF THE POWER SUPPLY TO MACHINE AND IT IS REQUIRED TO PREVENT BATTERY DISCHARGE.

N.B.-:THE ACTIV'SCREEN AUTOMATICALLY GOES INTO STANDBY IF IT IS NOT USED FOR AN EXTENDED PERIOD. TO SWITCH THE ACTIV'SCREEN BACK ON, ENTER THE CORRECT ACCESS CODE ON THE KEYPAD (C188) THEN FOLLOW THE START-UP PROCEDURE.

2.2 Movement control





Even at low movement speeds, use the controls with caution.

Press and hold 'Enable switch' button (9) to perform movements.

N.B.-:RELEASING THE ENABLE SWITCH WILL STOP ALL MOVEMENTS.

Ground box controls (emergency station)

Command	Action
Platform raising / lowering	 Press the 'raise platform' extension touchpad (1) to lift the platform.
	 Press the 'lower platform' extension touchpad (2) to lower the platform.

2.3 Additional controls from the ground control box

For the machines equipped with beacon light :

- Push the beacon light selector switch (105) upwards to turn ON the beacon light.
- Push the beacon light selector switch (105) downwards to turn OFF the beacon light.

D - Operation instructions

3 Platform control box

3.1 To start and stop the machine

To start the machine :

At the ground control box :

- The E-stop button (15) on the ground control box must be in ON position (pulled out / activated).

On the keypad (C188), enter the correct access code, press ENTER button, the ground control box is energized by default, then press PLTFM button to energize the platform control box.

At the platform control box :

- Pull the E-stop button (46).

To stop the machine :

- Press the OFF button to turn off power to the machine.

N.B.-:THE ACTIV'SCREEN AUTOMATICALLY GOES INTO STANDBY IF IT IS NOT USED FOR AN EXTENDED PERIOD. TO SWITCH THE ACTIV'SCREEN BACK ON, ENTER THE CORRECT ACCESS CODE ON THE KEYPAD (C188) THEN FOLLOW THE START-UP PROCEDURE.

3.2 Drive and steer control

To control the direction and drive :

- Move the 2-position selector (112) to the right.
- The drive indicator (111) lights up.
- Select a drive speed (45).
- Press and hold the enable switch (123)
- Activate the drive joystick (108).

N.B.-:THE DRIVE AND LIFT SPEEDS ARE PROPORTIONAL TO THE POSITION OF THE JOYSTICK. PUSHING THE JOYSTICK COMPLETELY BACKWARD OR UPWARD WILL INCREASE THE SPEED.

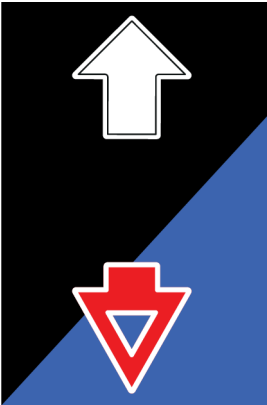
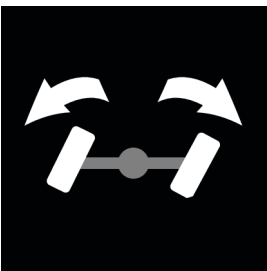
Command		Action
Driving		Move the drive joystick (108) backward to drive the machine forwards.
		Move the drive joystick (108) upward to reverse the machine.
Front-axle steering		Press the right side of the thumb button (108) on the joystick to steer the wheels to the right.
		Press the left side of the thumb button (108) on the joystick to steer the wheels to the left.

3.3 Elevation controls

To control raising and lowering :

- Move the 2-position selector (112) to the left

D - Operation instructions

- The elevation / lowering selection indicator (110) lights up.
- Press and hold the enable switch (123) and (245) (if equipped).
- Activate the movement joystick (108).

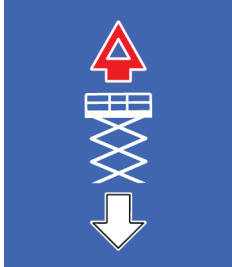
Command		Action
Platform raising / lowering		Move the movement joystick (108) upward to raise the (basket) platform.
		Move the movement joystick (108) downward to lower the (basket) platform.

3.4 Additional controls

- Horn : Push the horn selector (43) down to sound the horn. The horn stops when the selector switch is released.

D - Operation instructions

4 Rescue and emergency procedures

4.1 In case of power loss

In case of loss of the main power source, lower the basket (or platform) by pulling and holding the T-handle (C107) on the chassis. Releasing the handle stops the movement.

Pull T-handle for emergency lowering

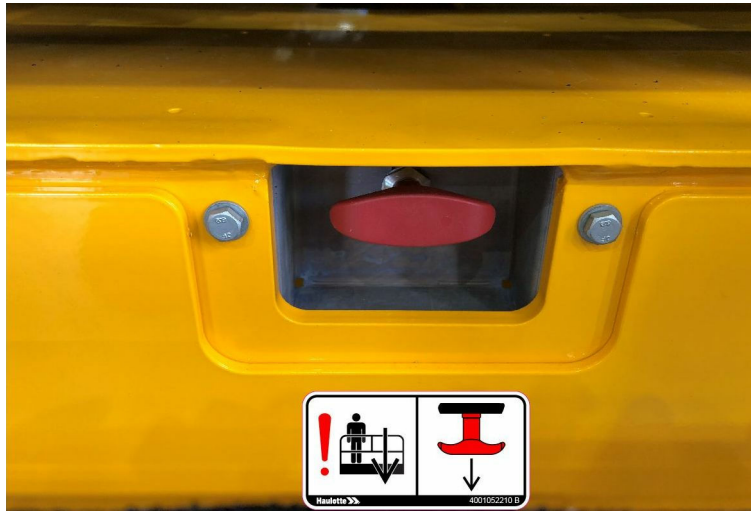

4.2 To rescue operator in platform

In a situation where an operator located in the platform needs to be rescued (for example in case of illness, injury or trapped against a structure making the control box inaccessible), the rescue personnel at ground level needs to obtain rapid and direct access to operating functions.

HAULOTTE® has implemented a control system for safely lowering the operator to the ground in the event of an emergency to enable him to receive the necessary treatment.



The system allows occupant(s) to be lowered to the ground level, even if an E-Stop is engaged or if an overload is detected.

1. On the keypad (C188), press GRND button to energize the ground control box. The platform box controls are de-energized.
2. Lower the platform from the ground control box using the platform lowering control (2) while pressing the enable switch (9).
3. Release it to halt lowering.



Once rescue operations are complete, write an incident report.

N.B.:-USE THE T-HANDLE (C107) SHOULD THE GROUND CONTROL BOX NOT BE ACCESSIBLE ( D 4.1 -IN CASE OF POWER LOSS) .

D - Operation instructions

5 Transportation

5.1 Transport configuration

The transport configuration of the machine is as follows :

- Extensions retracted and locked.
- Guardrails folded (if needed) .
- Extending structure (scissors) folded.
- Drive wheels parallel to the chassis.



During loading, ensure that :

- The loading ramp can support the machine weight.
- The loading ramp is correctly attached to transport vehicle.
- The loading ramp has sufficient grip surface.
- The transport vehicle must be parked on a level surface and must be secured to prevent rolling away while machine is being loaded or unloaded.



Always climb slopes in forward drive .

To climb the slope, move progressively the drive joystick (108).

If the slope is too steep, carry out the brake release procedure :  D 5.5.1 -Electric brake release.

Do not place yourself below or too close to the machine during loading.

The machine must be completely in the stowed configuration

- Check the platform is completely empty.
- Platform extension must be retracted in the locked position.
- Drive the machine onto the truck bed.
- Secure the machine to the tie down points provided ( D 5.3 -Machine stowage for transport) .



The manual extension (if fitted) must be retracted and locked during transport or towing.



Do not drive the machine from the platform with the guardrails folded.



In road position or when loading, fold the guardrails and disconnect the platform control box if necessary.

5.2 Folding guardrails

5.2.1 Description

Folding guardrails system is designed to allow guardrails to be lowered to reduce the overall height of the machine.

This system facilitates moving the machine through low height doorways/passages.

5.2.2 Safety precautions



- Place the machine on flat ground.
- Fully lower the platform to the stowed position.
- Take care to avoid trapping the hands while folding the guardrails.
- User must wear gloves.
- Keep hands clear of pinch points.

D - Operation instructions

5.2.3 Guardrail folding procedure

- Extension deck must be fully retracted and in locked position.
- The intermediate sliding entrance bar must be at its lowest position.

Guardrail order of folding

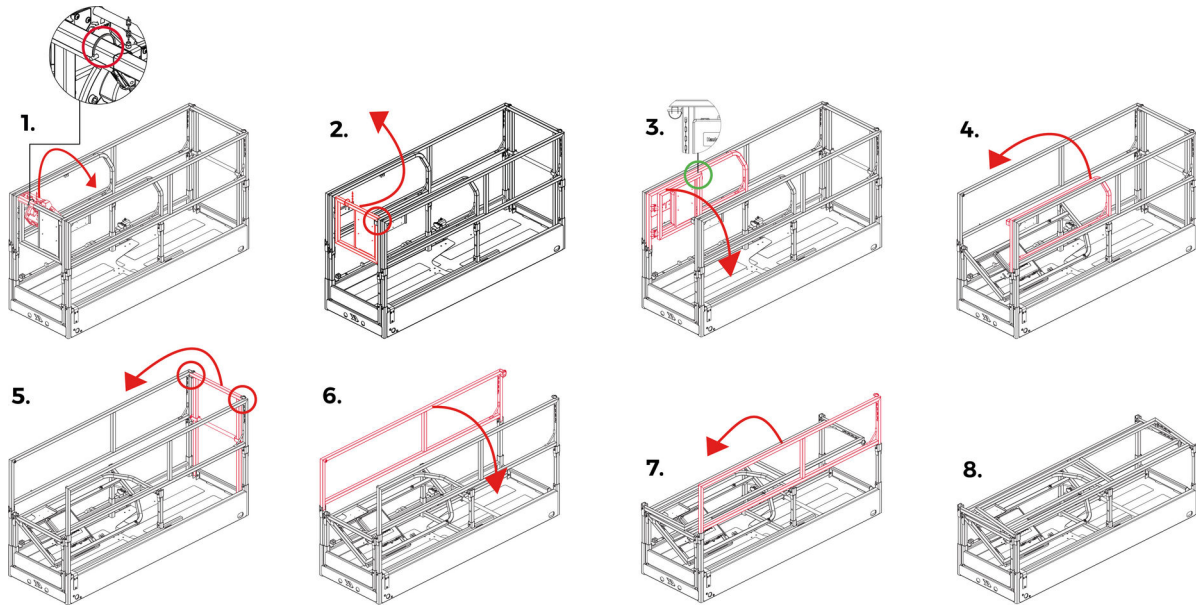

- Disconnect the platform control box.

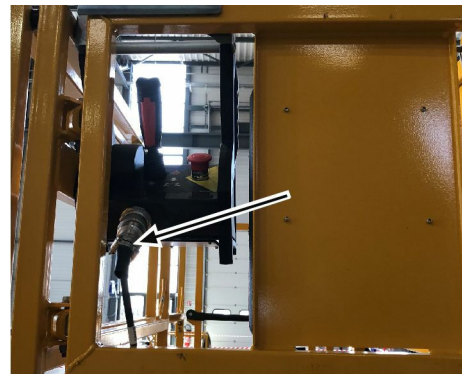

D - Operation instructions

- Remove the platform control box from its starting position and set it aside in a safe place.

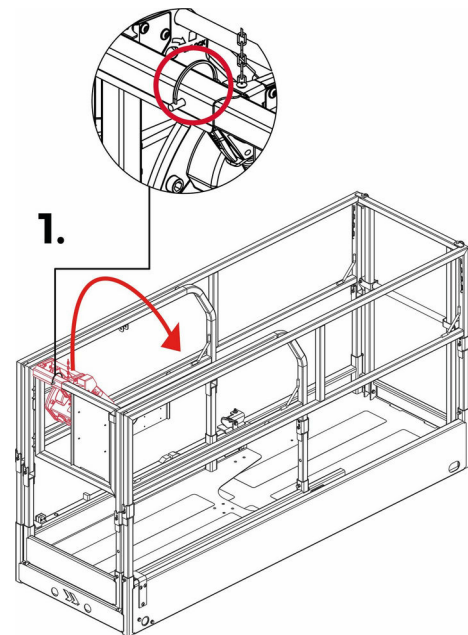

- Remove the lock pins as it folds down.
- Hold the guardrail that is to be folded down by hand to prevent it from falling over abruptly.

Open and fasten the front guardrail(2) (Control box side)

- Remove the pin .

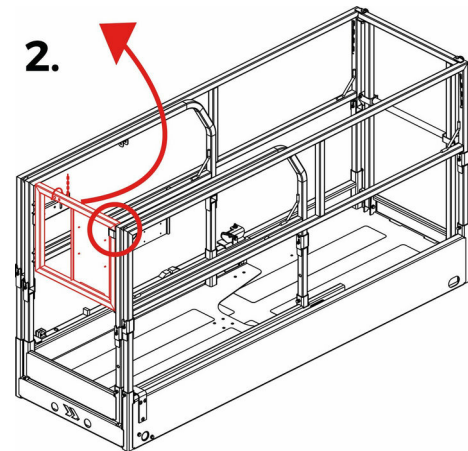

- Open the front guardrail and swing it onto the side guardrail.
- Position the pin on the guardrail of the right extension.



D - Operation instructions



The pin must be positioned as shown.

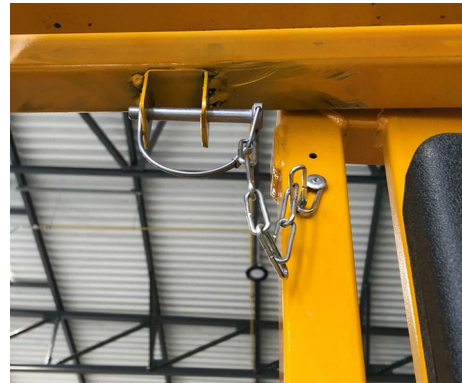

Right extension guardrail(3)

- Raise the guardrail and gently tilt it to the left, towards the platform floor.

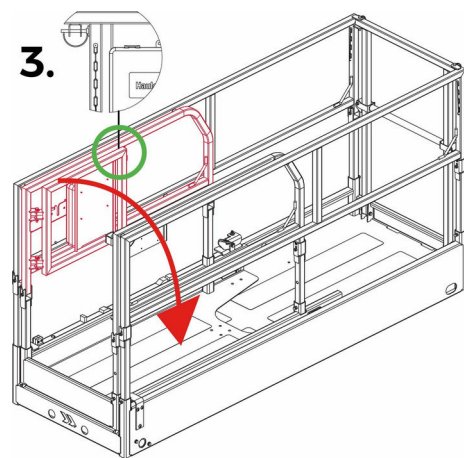

Left extension guardrail(4)

- Raise the guardrail and gently tilt it to the right until it comes into contact with the other guardrail.

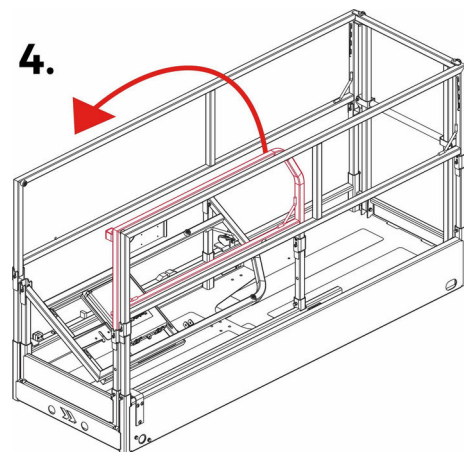

Rear guardrail(5) (Platform access side)

D - Operation instructions

- Get onto the platform.
- Remove the 2 pins .

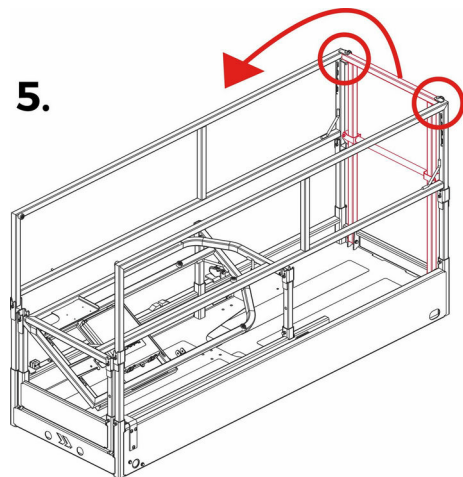

- Tilt the rear guardrail forwards, towards the platform floor.



Fall hazard : Use the individual rolling platform or a secure means of access to fold down the side guardrails.

Right side guard rail (6)

- Raise the guardrail and gently tilt it to the left until it comes into contact with the guardrails of the extension.

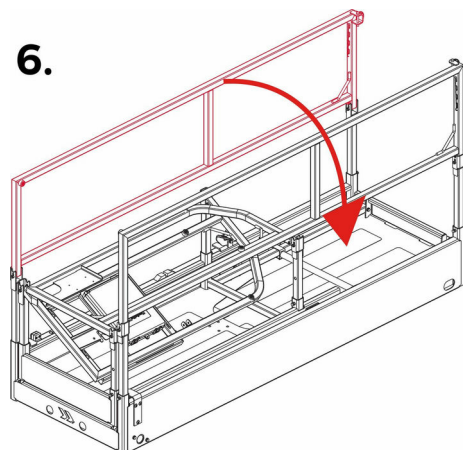

Left side guard rail (7)

D - Operation instructions

- Raise the guardrail and tilt it gently to the right until it comes into contact with the right side guardrail.

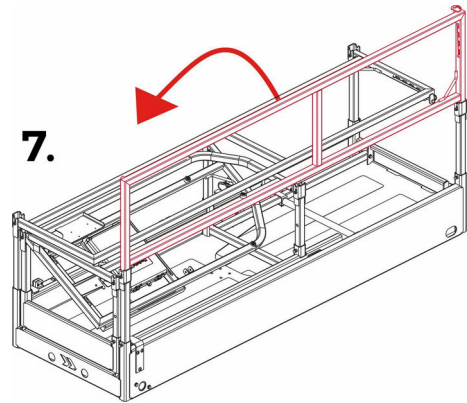

5.2.4 Specific decals

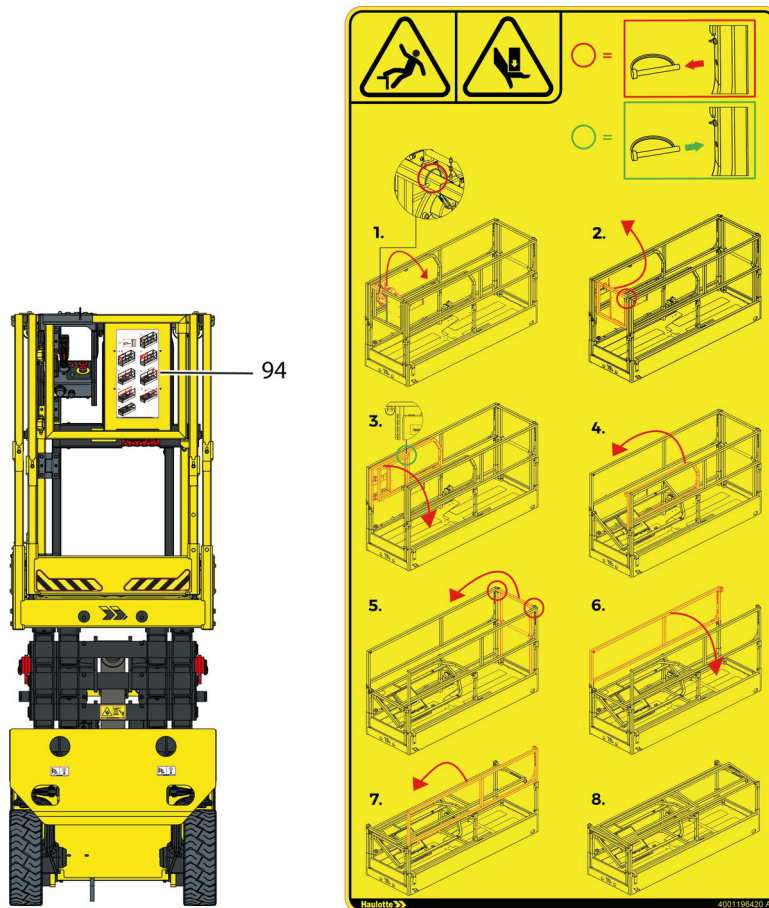

Marking	Description	Quantity	Part number
94	Explanation work and transport positions	1	For COMPACT 8N AE (COMPACT 2032E AE) - COMPACT 10N AE (COMPACT 2632E AE) : 4001197420 For COMPACT 10 AE (COMPACT 2647E AE) - COMPACT 12 AE (COMPACT 3247E AE) - COMPACT 14 AE (COMPACT 3947E AE) : 4001197660

D - Operation instructions

5.2.5 Raising guardrails to working position

To raise the folded guardrails to the vertical working position :

- Follow the fold-down procedure for the guardrails in reverse order.
- Ensure all pins are installed and secured.



Do not use the machine if the pins are missing, damaged or not approved by HAULOTTE®.



Do not use the machine when the guardrails are folded down to perform drive movements or raise the platform with personnel on board.

5.3 Machine stowage for transport

COMPACT 8N AE (COMPACT 2032E AE) - COMPACT 10N AE (COMPACT 2632E AE)

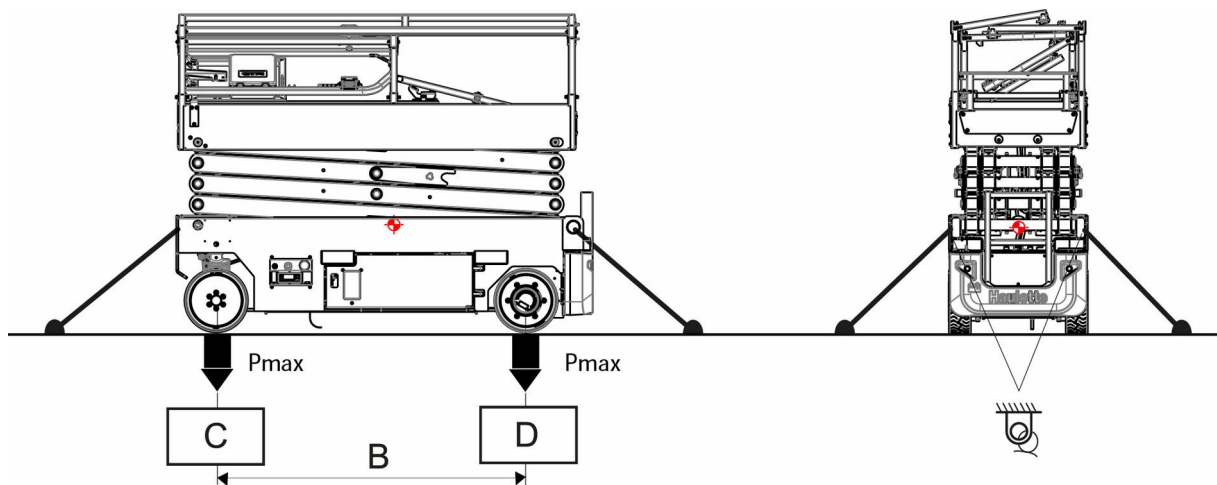

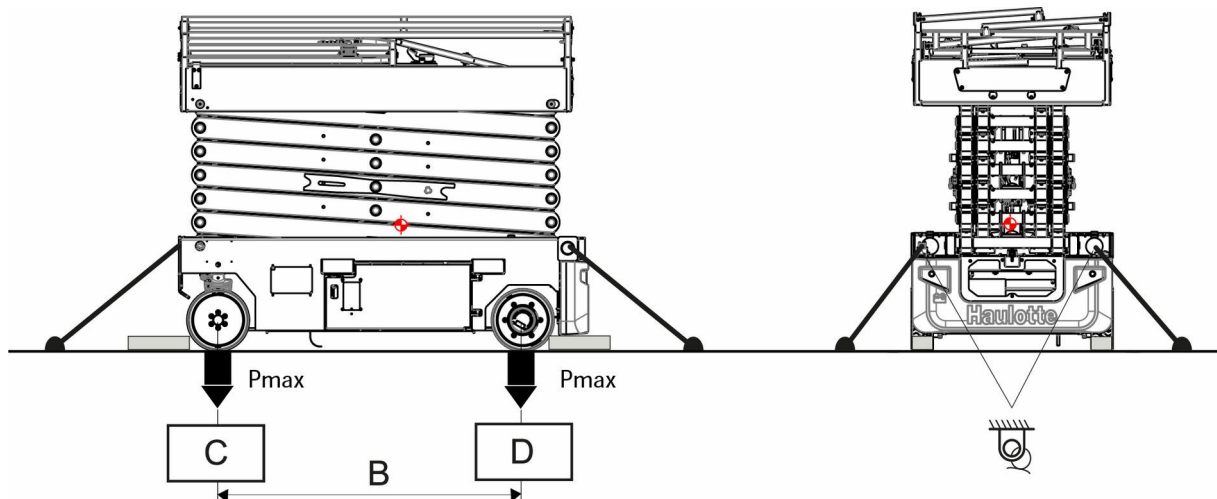

COMPACT 10 AE (COMPACT 2647E AE) - COMPACT 12 AE (COMPACT 3247E AE) - COMPACT 14 AE (COMPACT 3947E AE)





D - Operation instructions

Loading characteristics



Marking	Description	COMPACT 8N AE - COMPACT 2032E AE	COMPACT 10N AE - COMPACT 2632E AE
B	Lateral distance between the wheels	1,86 m(ft1 in)	
C	Front wheel ground pressure	15,3 daN/cm2 (222 lb/ft2)	15,3 daN/cm2 (222 lb/ft2)
D	Rear wheel ground pressure	15,3 daN/cm2 (222 lb/ft2)	15,3 daN/cm2 (222 lb/ft2)
	Anchorage point		
	Center of gravity	 E 1 - Machine dimensions	

Loading characteristics

Marking	Description	COMPACT 10 AE - COMPACT 2647E AE	COMPACT 12 AE - COMPACT 3247E AE	COMPACT 14 AE - COMPACT 3947E AE
B	Lateral distance between the wheels	1,86 m(ft1 in)		
C	Front wheel ground pressure	15,7 daN/cm2 (227.7 lb/ft2)	18,9 daN/cm2 (274 lb/ft2)	18,9 daN/cm2 (274 lb/ft2)
D	Rear wheel ground pressure	15,7 daN/cm2 (227.7 lb/ft2)	18,9 daN/cm2 (274 lb/ft2)	18,9 daN/cm2 (274 lb/ft2)
	Anchorage point			
	Center of gravity	 E 1 - Machine dimensions		

5.4 Unloading

Before unloading, check that the machine is in good condition.

- Remove the tie-down straps or chains.
- Unfold the guardrails : Refer to :  D 5.2 - Folding guardrails.
- On the keypad (C188), enter the correct access code, press ENTER button, the ground control box is energized by default, then press PLTFM button to energize the platform control box.
- From the platform control box, move the 2-position selector (112) to the right. Press and hold the enable switch (123) while gently and progressively moving the drive joystick (108) ( D 3.2 -Drive and steer control) .



The machine adapts the speed to the slope of the ramp.



Adjust the movement speed to the ground conditions (traffic, slope, etc.).

D - Operation instructions

5.5 Towing or winching (Slope crossing aid)



In the event of a machine breakdown, the machine can be towed a short distance to load it onto a transport vehicle

- Ensure that no one is in the platform during towing.
- Ensure that the machine is in transport configuration before towing.
- The platform must be empty.
- ALWAYS keep personnel and obstructions clear of the aerial work platform when brakes are released.

To tow a broken-down machine, release the brake (Refer to  D 5.5.1 - Electric brake release).

Perform this operation on flat ground with wheels chocked.

In the towing configuration, the machine braking system is inactive. Use a drawbar to avoid any risk of accident

- Do not exceed the maximum freewheel speed (Refer to  B 3 - Technical specifications).

Use a means with suitable capacity for loading the machine, in the event of crossing a ramp > 25%.

5.5.1 Electric brake release



To tow a broken-down machine, the brakes can be released using the electric system.

This device can also be used for crossing a ramp > 25% using a winch.



Perform these operations on flat, horizontal ground. Failing that, block the wheels to immobilize the machine. During brake release operation, the machine is in free wheel mode and the brake system no longer functions.

To release the machine's brakes, the following conditions must be met :

- The platform control box or the ground control box must be selected ( D 2 - Ground control box or  D 3 - Platform control box).
- The machine must be completely stowed.
- No movement selected.
- The machine must not be tilted.

Procedure :

- Hold brake switch upwards to activate the brake release.
- Hold down the brake release switch for more than 3s. An audible signal (beep) sounds.
- Releasing the switch releases the brakes.

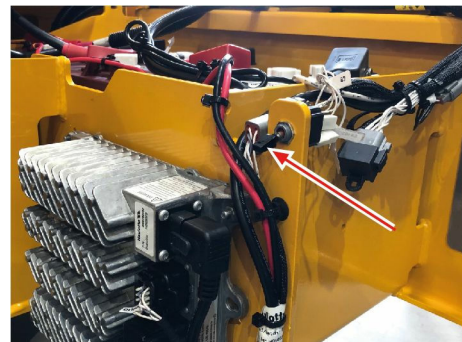

Brakes are applied automatically

- when the brake release switch is pressed again,
- when a command is sent from the lower or platform control box,
- the machine is turned off,

D - Operation instructions

- or the control box in use is changed.



In the towing configuration, the machine is no longer slowed down. Use a drawbar to avoid any risk of accident.



Do not exceed the maximum speed permitted by the machine ( B 3 - Technical specifications).

5.6 Storage



The machine can be stored in a designated area when not in use. If it is stored for more than 3 months without being used, an inspection must be carried out before it is put back into service.



Keep the batteries charged  D 7.3 - Optimise battery life.

Do not store or immobilise the machine when it is unfolded.

Ensure all access panels, doors and side compartment covers are shut and secured.

Press the OFF button to turn off power to the machine.

Do not disclose the access code to other people to prevent unauthorized operation of the machine.



Storing of the machine with an obstacle under the extended platform is forbidden.



When machine is stored and not used for more than 1 week, check the battery's state of charge, recharge if necessary.



To avoid any risk of corrosion on rods of cylinders during a storage period of more than 1 month :

- In a normal atmospheric environment : perform a complete cycle for the cylinders every 2 months while they are in storage.
- In harsh environments (high levels of salinity in the atmosphere: close to the sea, industrial environment with chloride emissions and/or humidity >70%), we recommend applying the following protection process :
 - Wash and rinse the entire machine with plenty of clean water.
 - Dry all the cylinder rods using an air gun.
 - Apply a solvent-based oil leaving an oily film after evaporation of the solvent directly to all rods left exposed when the machine is in storage position.
 - Re-apply the product every month.



After washing the machine, make sure it is fully air-dry and does not contain moisture on corrosive parts (cylinders rods for example). Do not wash electrical components with a high pressure washer. Wipe away dirt from around electrical components with a dry cloth.

5.7 Loading by ramp



Ensure that :

- The loading ramp can support the machine weight.
- The loading ramp is correctly attached to transport vehicle.
- The loading ramp has sufficient grip surface.

D - Operation instructions

- The transport vehicle must be parked on a level surface and must be secured to prevent rolling away while machine is being loaded or unloaded.



To climb the slope, select the  speed and move the drive joystick gradually.



Always climb slopes in forward drive .

If the slope is too steep, carry out the brake release procedure :  D 5.5.1 - Electric brake release.



Do not place yourself below or too close to the machine during loading.

The machine must be fully in transport configuration

- Check the platform is completely empty.
- Platform extension must be retracted in the locked position.
- Drive the machine onto the truck bed.
- Secure the machine to the tie down points provided ( D 5.3 - Machine stowage for transport) .
- The covers /swinging out trays must be closed and locked in position. A wrong move can lead to machine tipping over and may cause serious injuries and material damage.



The extension deck must be retracted and locked during transport or towing.

5.8 Unloading by ramp



Before operating, check that the machine is in good condition. If the machine has been damaged during transportation, contact the transporter in writing.



Never use a damaged or malfunctioning machine.

1. Remove the tie downs.
2. Switch the machine on.
3. Check that the ramps are in good condition and have sufficient capacity. The lifting equipment ie. slings, shackles, hooks, lifting beam etc. are in good condition and of sufficient capacity.
4. Move progressively the drive joystick .

5.9 Lifting operation

During loading/unloading operations using a hoist, it is important to observe the following

- Set the machine to transport configuration.
- Platform must be empty.
- Check that the lifting accessories are in good condition and selected according to the following technical characteristics. It is important that the lifting devices are attached only to the designated lifting eyes.



- Anchorage point for lifting are identified / labeled by the following symbol
- ONLY trained and authorized personnel should attempt to lift the machine.



Never lift the machine with slings attached to counterweight.

D - Operation instructions

5.9.1 Procedure for the use of slings COMPACT 8N AE (COMPACT 2032E AE) - COMPACT 10N AE (COMPACT 2632E AE)



B 3.1 - Technical specifications : Consult the table of technical characteristics to ascertain the total weight of the machine to be lifted.



The machine must be fully folded, with platform extension(s) retracted and locked in position.

Attach 4 shackles 2 T with the straps 3 m (9 ft 10 in) 2 T to the four lifting points on the chassis.



Front view of the machine



D - Operation instructions

Rear view of the machine



The slings must be positioned from inside of the railings as shown below.

D - Operation instructions

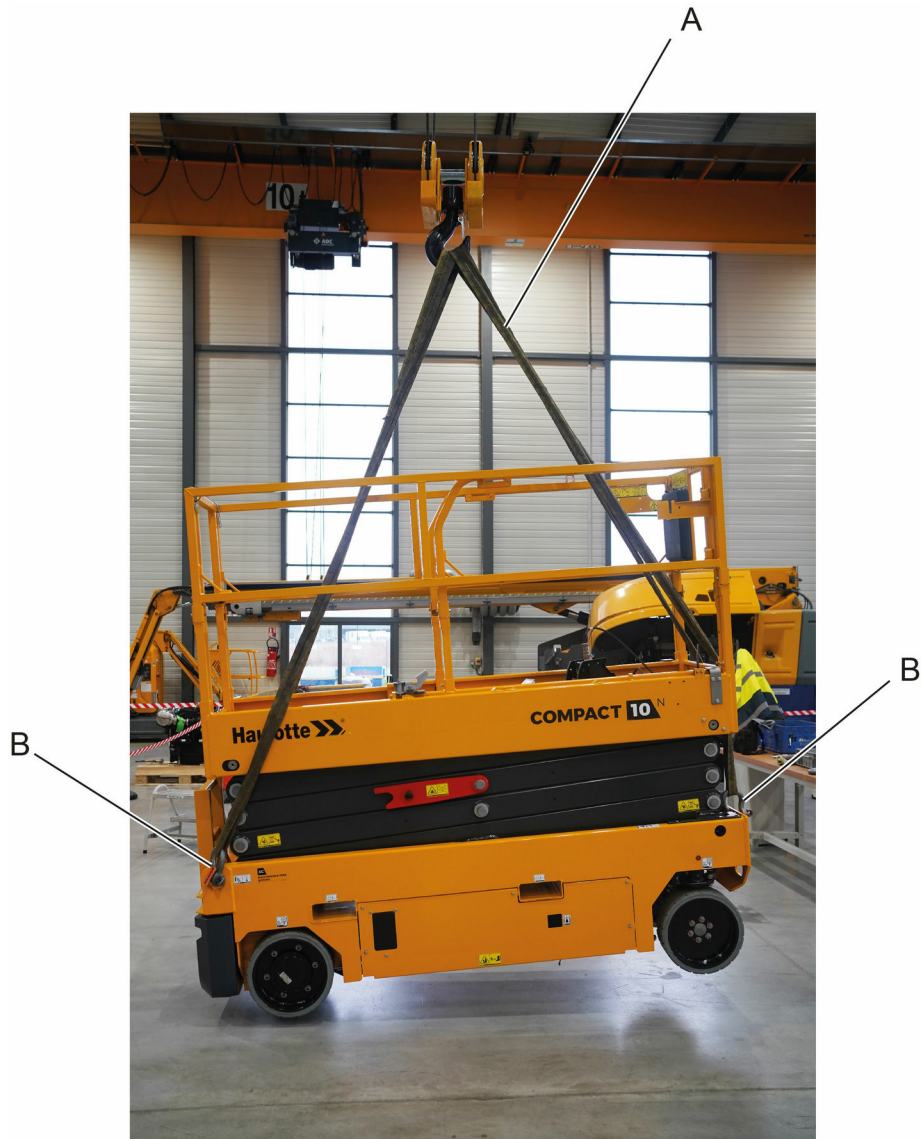

Ensure that the shackles are correctly locked.



The machine must be handled very slowly.



Never stand under or too close to the machine during lifting operations.

	Strap			Shackle	
	Number of slings	Minimum length	Minimum capacity	Number of shackles	Minimum capacity
A	4	3 m (9 ft 10 in)	2 T (4410 lbf)		
B				4	2 T (4410 lbf)



The 4 slings must be the same length.

D - Operation instructions

5.9.2 Procedure for the use of slings COMPACT 10 AE (COMPACT 2647E AE) - COMPACT 12 AE (COMPACT 3247E AE) - COMPACT 14 AE (COMPACT 3947E AE)



B 3.1 - Technical specifications : Consult the table of technical characteristics to ascertain the total weight of the machine to be lifted.



The machine must be fully folded, with platform extension(s) retracted and locked in position.

Attach 4 shackles 2 T with the straps 3 m (9 ft 10 in) 2 T to the four lifting points on the chassis.



Front view of the machine



D - Operation instructions

Rear view of the machine



The slings must be positioned from inside of the railings as shown below.

D - Operation instructions



Ensure that the shackles are correctly locked.



The machine must be handled very slowly.



Never stand under or too close to the machine during lifting operations.

	Strap			Shackle	
	Number of slings	Minimum length	Minimum capacity	Number of shackles	Minimum capacity
A	4	3 m (9 ft 10 in)	2 T (4410 lbf)		
B				4	2 T (4410 lbf)



The 4 slings must be the same length.

D - Operation instructions

5.10 Loading and unloading with forklift



The machine must be fully folded and in transport configuration.

- Ensure that the platform is empty and that the machine is in transport configuration (extension retracted and locked, extendable structure (scissors) folded up, directional wheels parallel to the frame, etc.).



The forklift used to load and unload must have a sufficient capacity and an adapted fork offset (Refer to  B 3.1 - Technical specifications) .



Risk of overturning : Refer to  E 1 - Machine dimensions to identify the centres of gravity.



The operator must be trained and authorised in how to use and drive a forklift.

- Adjust the forklift forks spread to match with the machine fork pockets.
- Carefully insert the forklift forks in the designated machine fork pockets.



Check the protrusion of the forks and ensure the machine is correctly positioned.

- Carefully lift the machine and make sure that the machine weight is properly balanced.
- Move the machine without sudden movements and at a reduced speed.

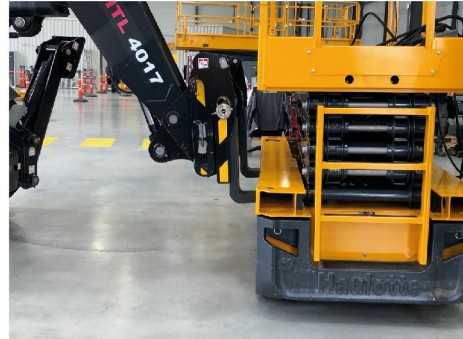

Never place yourself below or too close to the machine during loading. A wrong move can lead to machine tipping over and may cause serious injuries and material damage.

Unloading

- Carefully lift the machine and make sure that the machine weight is properly balanced.
- Move the machine without sudden movements and at a reduced speed
- Slowly lower the machine and place it on the ground.

D - Operation instructions

6 Cold Weather Recommendations

In an extremely cold environment, the machines must be equipped with a specific hydraulic oil.



In cold weather, do not store the machine with discharged batteries. It is recommended that, at a temperature below 0 °C(32 °F) , the machine not be stored with a battery charge of below 75 %.

6.1 Hydraulic oil



External environmental conditions can reduce performance of the machine if the hydraulic oil temperature does not reach its optimum range.

It is recommended to use the hydraulic oil according to weather condition. Refer to the table below.

Environmental conditions	SAE Viscosity grade
Ambient temperature between - 15°C (5°F) and + 40°C (+ 104°F)	HV 32
Ambient temperature between - 35°C (- 31°F) and + 35°C (+ 95°F)	HV 32 Arctic

N.B.-:YOU ARE ADVISED TO REPLACE THE LOW TEMPERATURE OIL HV 32 ARCTIC WHEN THE AMBIENT TEMPERATURE REACHES + 15°C (59°F). IT IS NOT ADVISABLE TO MIX OILS OF DIFFERENT BRANDS OR TYPES.

D - Operation instructions

7 Battery care and maintenance

7.1 Battery recharge

7.1.1 On-board charger

The on-board charger is used to charge the semi-drive batteries. The charger's power is 750W-1000W and the maximum intensity is 10A for 220V - 240V and 110V networks. Battery charging starts as soon as it is connected via the mains supply.

N.B.:-NO MOVEMENTS ARE ALLOWED DURING BATTERIES CHARGING CYCLE AND WHILE CONNECTED TO AN EXTERNAL POWER OUTLET.

	
Battery charger	36V / 27A
Electric power supply	85 - 265 Vac / 50-60Hz / 10A max
Battery voltage	24V
Indicative charging time	10h

Locations

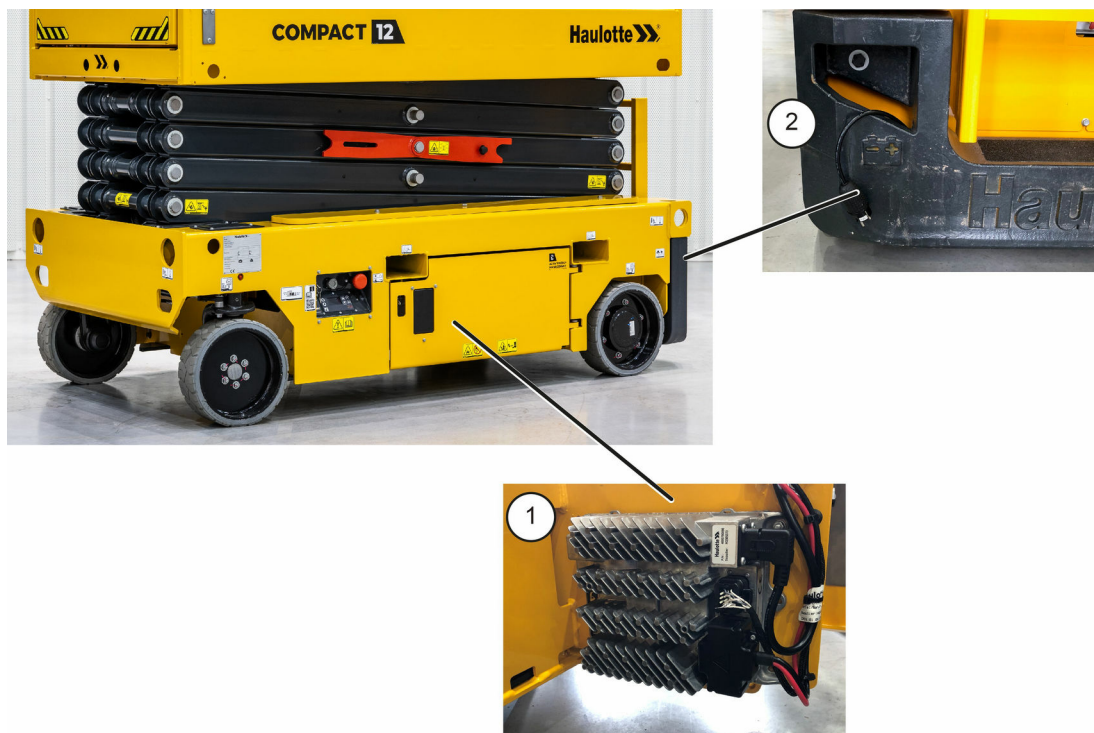

D - Operation instructions

Marking	Description
1	On-board charger
2	Battery charger mains cable



Never replace the charging cable without written permission from HAULOTTE®.

7.1.2 Battery charging

Connect the machine to an external electrical network using a power supply cable provided by HAULOTTE®. The network must be protected by a C curve 30mA differential breaker.



- Do not use an external charger or jump the batteries.
- Ensure that the mains power supply is suitable and regulated :
 - Do not use a cable reel with the cable wound up.
 - The socket must be able to deliver a current of 10 A.

Duration of charge cycle



- 10 hours approximately, on 220 - 240 V AC network.

The charge cycle stops automatically when charging is complete.

It can take up to 24 hours for a full charge if the battery levels are very low (Charge status less than 5 %).

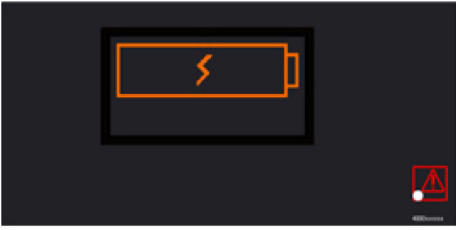
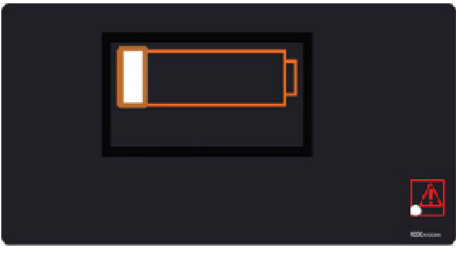
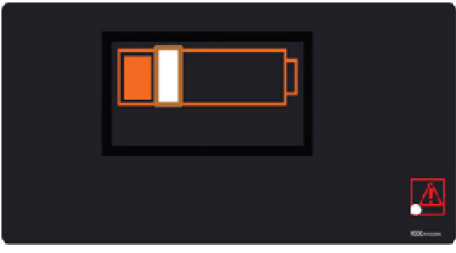

D - Operation instructions

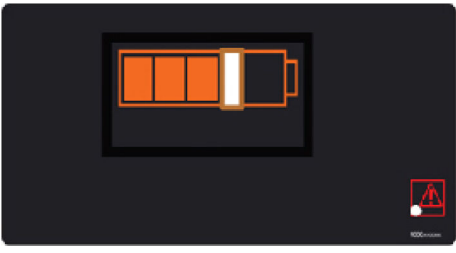
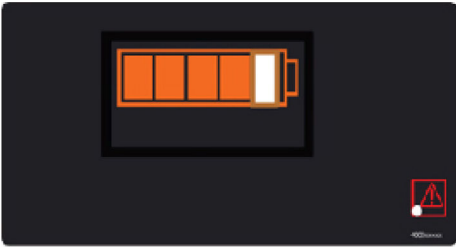
Information on LCD screen

<p>Charging is going to start</p>		
<p>The first segment flashes</p>		<p>Charge from 0 % to 20 %</p>
<p>The second segment flashes</p>		<p>Charge from 20 % to 40 %</p>
<p>The third segment flashes</p>		<p>Charge from 40 % to 60 %</p>
<p>The fourth segment flashes</p>		<p>Charge from 60 % to 80 %</p>
<p>The fifth segment flashes</p>		<p>Charge from 80 % to 100 %</p>

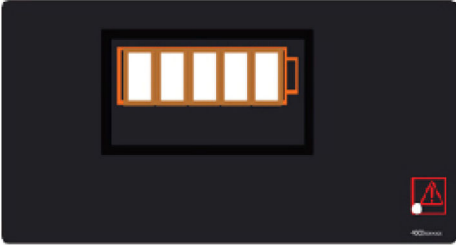

D - Operation instructions

Information on LCD screen

<p>Battery equalisation The 5 segments flash</p>		<p>Automatic maintenance cycle prolongs the service life of the batteries</p>
<p>Charging is complete</p>		<p>Unplug the charging cable from the machine</p>

7.1.3 Fault codes

Should the battery charger malfunction, the warning lights (7) and (8) on the LCD "ActivScreen" screen located on the ground control box alert the operator :

Marking	Icon	Function
7		Machine is charging - Indicator on : Charging malfunction
8		Machine is charging - Indicator on : Battery temperature malfunction

Refer to the Service Manual :  D 1 Trouble shooting.

7.2 Battery care and maintenance

 Handling batteries presents significant risks due to the chemical and corrosive substances that they contain and the possibilities of explosion, fire, electrocution, etc

 Always handle batteries with care.

 Risk of burns : Always wear protective clothing and glasses.

 Refer to the maintenance manual for operations on the batteries: MP0049 sheet : Battery electrolyte level - Filling batteries.

D - Operation instructions

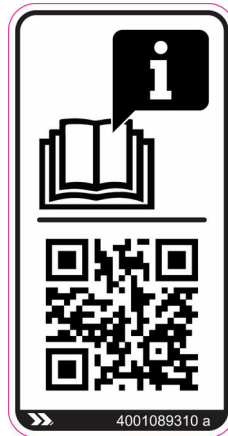

7.2.1 Manual centralized battery filling (Optional)

Single-Point Watering System

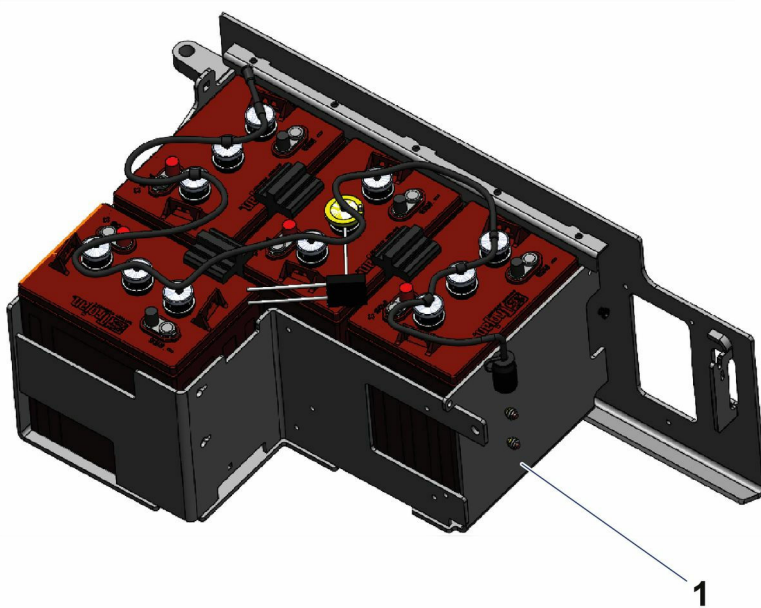
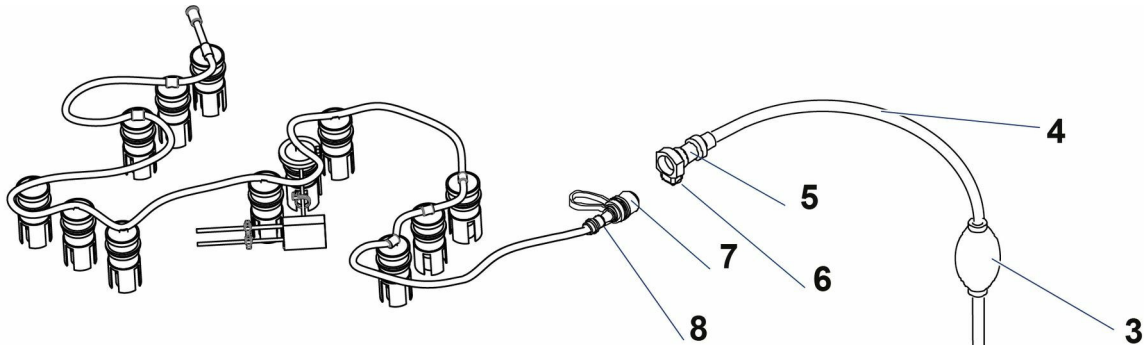

D - Operation instructions

Marking	Description
1	Battery
2	Filtered intake
3	Hand pump
4	Hose
5	Female adapter
6	Push-button
7	Dust cover
8	Male adapter

1. Launch a full charge of the battery and check the charge indicator.
2. Disconnect the batteries charger and put back the plug in its housing.

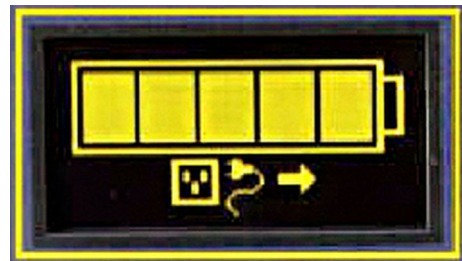

Levelling of the elements should always be done after charging the batteries. Watering a battery before charge (or with a low charge level) can lead to boil-over, resulting in potential bodily injury and potential damage to the watering system and the battery.

1. Open the battery compartment.



1. Immerse the filtered inlet (2) of the transparent pipe (4) equipped with a hand pump (3) in a container of deionized water (Supplied with the machine) .
2. Press the hand pump (3) to prime it until the water rises in the hose (4)
3. Once the hand pump (3) is primed, remove the male connector (8) cap (7) from the black supply tube assembly
4. Connect the female connector (5) quick-hitch from the centralized filling system, including the hand-pump, to the male connector (8) .
5. Press firmly on the hand pump to bring the distilled water to the batteries (1) .
6. When the hand pump (3) becomes resistant, this means that all of the battery cells are filled to the appropriate level.
7. Then uncouple the female connector (5) from the male connector (8) filling tube by pressing on the yellow button (6), then replace the cap (7) on the machine hose.
8. Close the battery compartment again.

D - Operation instructions

7.2.2 Automatic battery filling (Optional)

1. Open the battery compartment.



1. Open the cap.
2. Fill the can with demineralized water.
3. Correctly close the plug and battery compartment.
4. Fully recharge the batteries in order to restart an automatic filling or activate the automatic filling from the Activ'Screen of the ground control box.

Procedure

- Go to the machine set-up menu-> 3.3Machine config-> 3.3.1Option setting-> Activ'Energy Management -> Auto.



7.2.3 Desulfation charge

Normal battery use leads to sulfatation of the lead plates during discharge (Formation of lead sulfate) . Recharging the battery dissolves the lead sulfate. The plates are desulfated.

Moreover, sulfatation also appears if the battery self-discharges during storage in a low state-of-charge (< 70%).

As the battery ages, the lead sulfate may become harder and harder and increasingly difficult to eliminate by normal charging. This leads to a loss of autonomy. The desulfation charge is a way of regenerating the battery.

Procedure

- Go to the machine set-up menu-> 3.3Machine config-> 3.3.1Option setting->Desulfation charge.

Desulfation charge



- The option is active and will be implemented during the next mains charge.
- The recharge time can then be 72 h.
- For high efficiency in this charging mode, the batteries must be below 30%.

D - Operation instructions

7.3 Optimise battery life

To optimize battery performance and life-time, you are advised to follow the recommendations below

- Carry out regular battery maintenance as described.
- Do not store the machine discharged (Duration greater than 72 hours) .
- Carry out full charges regularly.
- Do not keep a machine in a state-of-charge less than 70% for no useful purpose.



- A full recharge of the batteries is recommended every 30 days that the machine is used.

Keep the top of the batteries clean and dry. Incorrect connection or corrosion may cause a high loss of power.

	Full charge	Filling control	Desulfation charge
In use			
As soon as possible	X		
If state-of-charge < 50% at the end of a working day	X		
Every 30 days of use	X		
Before placing in storage	X		
1 time a week	X	X	
1 time every 6 months			X
In storage			
1 time a month	X		



- The battery's water consumption depends on its use. You are advised to check the water level 1 time a week.

E - General Specifications

1	Machine dimensions.....	3
2	Masses of the main sub-assemblies.....	6
3	Acoustics and vibrations.....	8
4	Wheel/Tire assembly.....	9
4.1	Technical specifications.....	9
4.2	Inspection and maintenance.....	9
4.2.1	Procedure of replacement.....	10
5	Options.....	11
5.1	Swing gate.....	11
5.1.1	Description.....	11
5.1.2	Characteristics.....	11
5.1.3	Safety precautions.....	11
5.1.4	Pre-operation instructions.....	11
5.1.5	Specific decals, optional.....	12
5.2	Pipe holder option.....	12
5.2.1	Description.....	12
5.2.2	Characteristics.....	12
5.2.3	Safety precautions.....	12
5.2.4	Pre-operation inspection.....	13
5.2.5	Operation.....	13
5.2.6	Disassembly - Assembly.....	14
5.2.7	Specific decals	15
5.3	Panel carrier.....	15
5.3.1	Description.....	15
5.3.2	Characteristics.....	16
5.3.3	Safety precautions.....	16
5.3.4	Pre-operation inspection.....	16
5.3.5	Operation.....	16
5.3.6	Disassembly - Assembly.....	17
5.3.7	Specific decals	19
5.4	SGS - SECONDARY GUARDING SYSTEM	19
5.4.1	Foreword.....	19
5.4.2	Safety precautions.....	19
5.4.3	Familiarization.....	20
5.4.4	How the system works.....	21
5.4.5	Inspecting the system before using the machine.....	23
5.4.6	Operating and using the SGS.....	24
5.4.7	Evacuation procedure if the operator is crushed or loses consciousness.....	24

E - General Specifications

1 Machine dimensions

Stowed / Transport position : Configuration that takes the minimum floor space necessary for storage and / or delivery of the machine-**Access position-** COMPACT 8N AE (COMPACT 2032E AE) - COMPACT 10N AE (COMPACT 2632E AE) - COMPACT 10 AE (COMPACT 2647E AE) - COMPACT 12 AE (COMPACT 3247E AE) - COMPACT 14 AE (COMPACT 3947E AE)

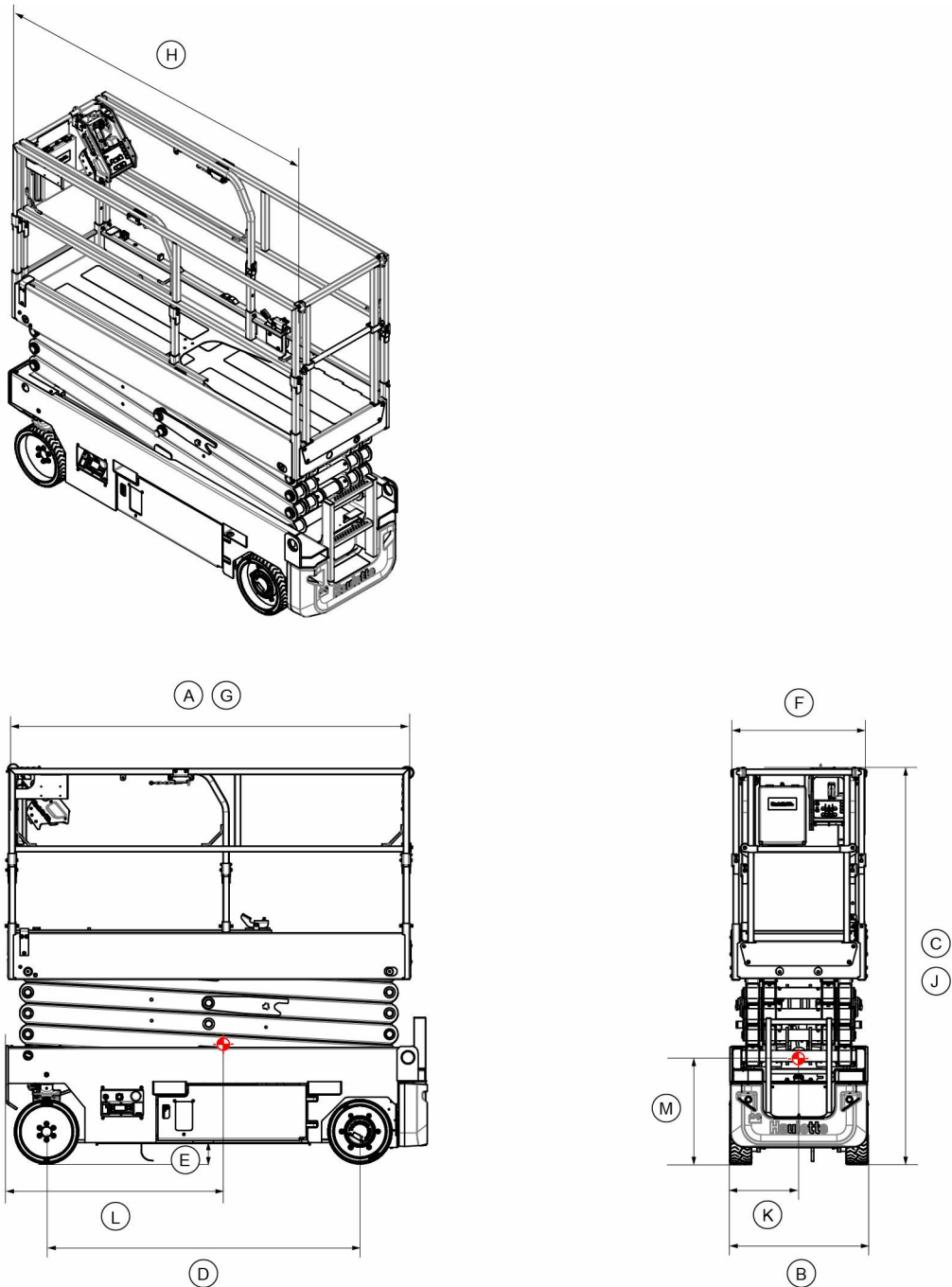

E - General Specifications

Overall dimension specifications

Machine		COMPACT 8N AE - COMPACT 2032E AE		COMPACT 10N AE - COMPACT 2632E AE	
Marking	Specifications-Dimensions	SI	Imp.	SI	Imp.
A - H	Overall length of machine-Storage length	2,50 m	8 ft 2 in	2,50 m	8 ft 2 in
B	Overall width of machine	0,81 m	2 ft 8 in	0,81 m	2 ft 8 in
C - J	Overall height of machine-Storage height	2,23 m	7 ft 4 in	2,35 m	7 ft 9 in
D	Wheel base	1,86 m	6 ft 1 in	1,86 m	6 ft 1 in
E	Ground clearance	12,5 cm	5 in	12,5 cm	5 in
F X G	Platform dimensions	0,80 m x 2,40 m	2 ft 7 in x 7 ft 10 in	0,80 m x 2,40 m	2 ft 7 in x 7 ft 10 in
K	Center of gravity- X	0,41 m	1 ft 4 in	0,41 m	1 ft 4 in
L	Center of gravity- Y	1,45 m	4 ft 9 in	1,45 m	4 ft 9 in
M	Center of gravity- Z	0,60 m	2 ft 0 in	0,66 m	2 ft 2 in
	Outside turning radius	2,05 m	6 ft 9 in	2,05 m	6 ft 9 in
	Inside turning radius	0,46 m	1 ft 6 in	0,46 m	1 ft 6 in

Overall dimension specifications

Machine		COMPACT 10 AE - COMPACT 2647E AE		COMPACT 12 AE - COMPACT 3247E AE	
Marking	Specifications-Dimensions	SI	Imp.	SI	Imp.
A - H	Overall length of machine-Storage length	2,50 m	8 ft 2 in	2,50 m	8 ft 2 in
B	Overall width of machine	1,20 m	3 ft 11 in	1,20 m	3 ft 11 in
C - J	Overall height of machine-Storage height	2,35 m	7 ft 9 in	2,47 m	8 ft 1 in
D	Wheel base	1,86 m	6 ft 1 in	1,86 m	6 ft 1 in
E	Ground clearance	12,5 cm	5 in	12,5 cm	5 in
F X G	Platform dimensions	1,20 m x 2,40 m	3 ft 11 in x 7 ft 10 in	1,20 m x 2,40 m	3 ft 11 in x 7 ft 10 in
K	Center of gravity- X	0,61 m	2 ft 0 in	0,61 m	2 ft 0 in
L	Center of gravity- Y	1,45 m	4 ft 9 in	1,45 m	4 ft 9 in
M	Center of gravity- Z	0,65 m	2 ft 2 in	0,70 m	2 ft 4 in
	Outside turning radius	1,83 m	6 ft 0 in	1,83 m	6 ft 0 in
	Inside turning radius	0,59 m	1 ft 1 in	0,59 m	1 ft 11 in

E - General Specifications

Overall dimension specifications

Machine		COMPACT 14 AE - COMPACT 3947E AE	
Marking	Specifications-Dimensions	SI	Imp.
A - H	Overall length of machine-Storage length	2,50 m	8 ft 2 in
B	Overall width of machine	1,20 m	3 ft 11 in
C - J	Overall height of machine-Storage height	2,72 m	8 ft 11 in
D	Wheel base	1,86 m	6 ft 1 in
E	Ground clearance	12,5 cm	5 in
F X G	Platform dimensions	1,20 m x 2,40 m	3 ft 11 in x 7 ft 10 in
K	Center of gravity- X	0,61 m	2 ft 0 in
L	Center of gravity- Y	1,45 m	4 ft 9 in
M	Center of gravity- Z	0,80 m	2 ft 7 in
	Outside turning radius	1,83 m	6 ft 0 in
	Inside turning radius	0,59 m	1 ft 11 in

E - General Specifications

2 Masses of the main sub-assemblies

N.B.-MASSES MEASURED WITH EMPTY TANKS.

Specifications	COMPACT 8N AE	COMPACT 2032E AE
	SI	Imp.
Frame assembly mass	1240 kg	2734 lbs
Scissors assembly mass	650 kg	1433 lbs
Platform assembly mass	250 kg	551 lbs
Steer wheel mass	20 kg	44 lbs
Drive wheel mass	17,5 kg	39 lbs
Mass of the main counterweight	168 kg	370 lbs
Mass of the additional counterweight	160 kg	353 lbs
Bare battery mass	120 kg	265 lbs

Specifications	COMPACT 10N AE	COMPACT 2632E AE
	SI	Imp.
Frame assembly mass	1090 kg	2403 lbs
Scissors assembly mass	820 kg	1808 lbs
Platform assembly mass	250 kg	551 lbs
Steer wheel mass	20 kg	44 lbs
Drive wheel mass	17,5 kg	39 lbs
Counterweight mass	168 kg	370 lbs
Bare battery mass	120 kg	265 lbs

Specifications	COMPACT 10 AE	COMPACT 2647E AE
	SI	Imp.
Frame assembly mass	1370 kg	3020 lbs
Scissors assembly mass	820 kg	1808 lbs
Platform assembly mass	300 kg	661 lbs
Steer wheel mass	20 kg	44 lbs
Drive wheel mass	17,5 kg	39 lbs
Counterweight mass	288 kg	635 lbs
Bare battery mass	120 kg	265 lbs

E - General Specifications

Specifications	COMPACT 12 AE	COMPACT 3247E AE
	SI	Imp.
Frame assembly mass	1530 kg	3373 lbs
Scissors assembly mass	1110 kg	2447 lbs
Platform assembly mass	300 kg	661 lbs
Steer wheel mass	20 kg	44 lbs
Drive wheel mass	17,5 kg	39 lbs
Mass of the main counterweight	290 kg	639 lbs
Mass of the additional counterweight	130 kg	287 lbs
Bare battery mass	120 kg	265 lbs

Specifications	COMPACT 14 AE	COMPACT 3947E AE
	SI	Imp.
Frame assembly mass	1430 kg	3153 lbs
Scissors assembly mass	1340 kg	2954 lbs
Platform assembly mass	300 kg	661 lbs
Steer wheel mass	20 kg	44 lbs
Drive wheel mass	17,5 kg	39 lbs
Counterweight mass	288 kg	635 lbs
Bare battery mass	120 kg	265 lbs

E - General Specifications

3 Acoustics and vibrations

The acoustics and vibrations specifications are based upon the following conditions :

- The airborne noise emissions at workstation are determined per European Directive 2006/42/CE.
- The guaranteed sound power level LWA (displayed on the product) is determined per European Directive 2000/14/CE.
- The vibrations transmitted by the machinery to the hand/arm system and to the whole body are determined per European Directive 2006/42/CE.

Specifications	
Sound pressure level at workstation	< 70 dBA
Vibrations hand/arm	Vibration transmitted by this MEWP to the hand-arm does not exceed 2,5 m/s ² (98,4 in/s ²)
Vibrations whole body	Vibration transmitted by this MEWP to the whole body does not exceed 0,5 m/s ² (19,6 in/s ²)

E - General Specifications

4 Wheel/Tire assembly

4.1 Technical specifications

Component	Standard wheel	Variant wheels
Type	Solid tires/tyres	
Drive wheel mass	17,5 kg - 39 lb	20,8 kg - 46 lb
Steer wheel mass	20 kg - 44 lb	23,3 kg - 51 lb
Wheel diameter (100%)	380 mm (14,96 in)	
Wheel diameter at 25% wear	365 mm (14,37 in)	
Wheel width	129 mm (5,07 in)	
Torque	115 Nm (84.81 ft lbs)	

4.2 Inspection and maintenance

Replace the wheels under the following conditions

- Presence of cracks, damage, deformation or other faults on the hub
- Visible damage to the wheel :
 - Rip or hole greater than or equal to 3 cm (2 in) in the rubber profile over the entire thickness.
 - Blister or pronounced lump on the external and lateral wall.
 - Damaged wheel stud.
 - Damage or wear on the side wall to the extent that the reinforcing wire is visible.
 - Consistent wear of the ground contact surface greater than 25%

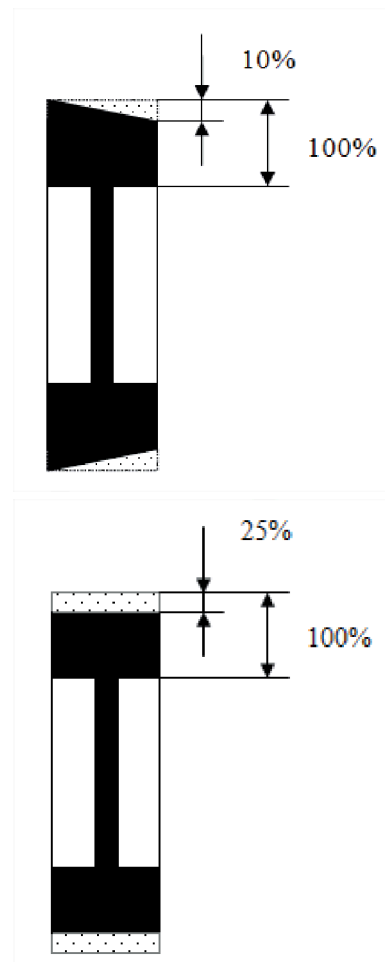

The wheels are essential components for the machine's stability. For safety reasons

- Use only HAULOTTE® spare parts according to the technical characteristics of the machine. Refer to the spare parts catalog.
- Do not replace the wheels installed in the factory with wheels bearing different characteristics.



Refer to the Service Manual : Machine sheets : MS0362 and MS0363.

E - General Specifications

4.2.1 Procedure of replacement

- Loosen the wheel nuts on the wheel to be removed.
- Raise the machine using a jack or a hoist with a suitable capacity.
- Remove the wheel nuts.
- Remove the wheel.
- Install the new wheel.
- Tighten the nuts to lock the wheel.
- Lower the machine to the ground.
- Tighten the wheel nuts to the recommended torque.

E - General Specifications

5 Options

5.1 Swing gate

5.1.1 Description

SWING GATE consists of a laterally mounted pivoting $\frac{1}{2}$ gate with closing latch, which enables a better access to platform. Spring loaded hinges and a latching mechanism allows the gate to swing inwards only.

Swing gate



5.1.2 Characteristics

Width of the gate : 534 mm / 22 in

5.1.3 Safety precautions



- The door forms part of the guardrail system and must be closed after entering the platform.

5.1.4 Pre-operation instructions

- Check that the locking mechanism is correctly fastened.
- Check the hinges and latch operate correctly and are not deformed.
- Ensure that the gate returns automatically to the closed and fastened position after entering or exiting the platform.

E - General Specifications

5.1.5 Specific decals, optional

Location of the decals

OPTION UPPER SWING GATE

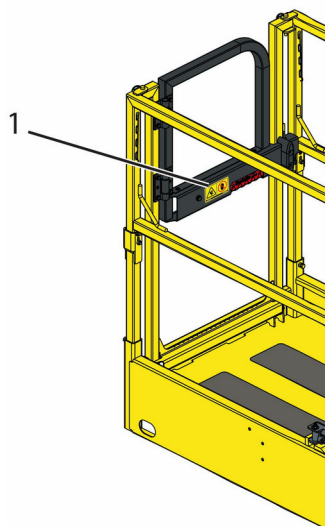

OPTION LOWER SWING GATE

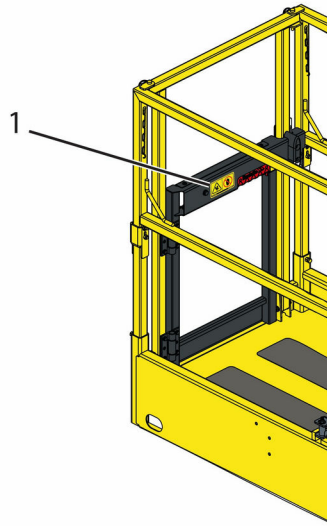

Marking	Description	Quantity	Part number
1	Hand crushing hazard	1	4001052080

5.2 Pipe holder option

5.2.1 Description

This attachment is an assembly designed to transport pipes and tubes. The assembly comprises of 2 cradles securely attached to the platform. The tube should be placed in the cradles and securely fixed to them with a strap.

5.2.2 Characteristics

Specifications	SI	Imp.
Weight of the carrier	11,5 kg	25 lbs
Weight of the equipment on the carrier	70 kg	154 lbs
Maximum load surface	0,8 m ² (Ø 0,12 m x 4 m)	6.4 sq.ft (Ø 0,4 ft x 13 ft 1 in)
Maximum wind speed allowed	0 m/s - 0 km/h	0 mph

5.2.3 Safety precautions



- Please read and assimilate the instructions before using the attachment.
- This attachment is designed for transporting pipes and tubes. Do not use this attachment for transporting other types of load. .
- Do not suspend loads.
- Do not overload the attachment and ensure that the material is correctly attached by straps.
- Do not exceed the maximum allowable platform capacity. The combined weight of the attachment, load, the occupants, the tools and any other equipment must not exceed the maximum allowable platform capacity.

E - General Specifications

- When maneuvering, ensure you maintain a safe distance between the load and the obstacles in the work environment.



It is prohibited to use this option outdoors (Wind load on the machine—Loss of machine stability) .

5.2.4 Pre-operation inspection



- Check that the cradle has no cracks or other damage.
- Check that the cradle is correctly installed and secured to the platform (Ensure fastening screws are tightened and pins correctly positioned) .
- Check that the information decal is present on the cradle and is legible.
- Check that the strap(s) is(are)not twisted or torn.
- Check that the position of the load and attachment is not obstructing access to the platform or the controls.
- Check that the position of the attachment and the load is not reducing visibility during maneuvers in the work environment.

5.2.5 Operation

- Position and centre the load to rest on the 2 cradles.
- Securely attach the load to each cradle with supplied straps.

Strapping example(s)

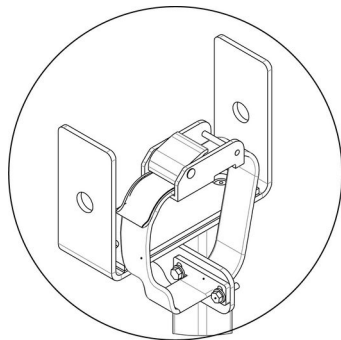

E - General Specifications

5.2.6 Disassembly - Assembly

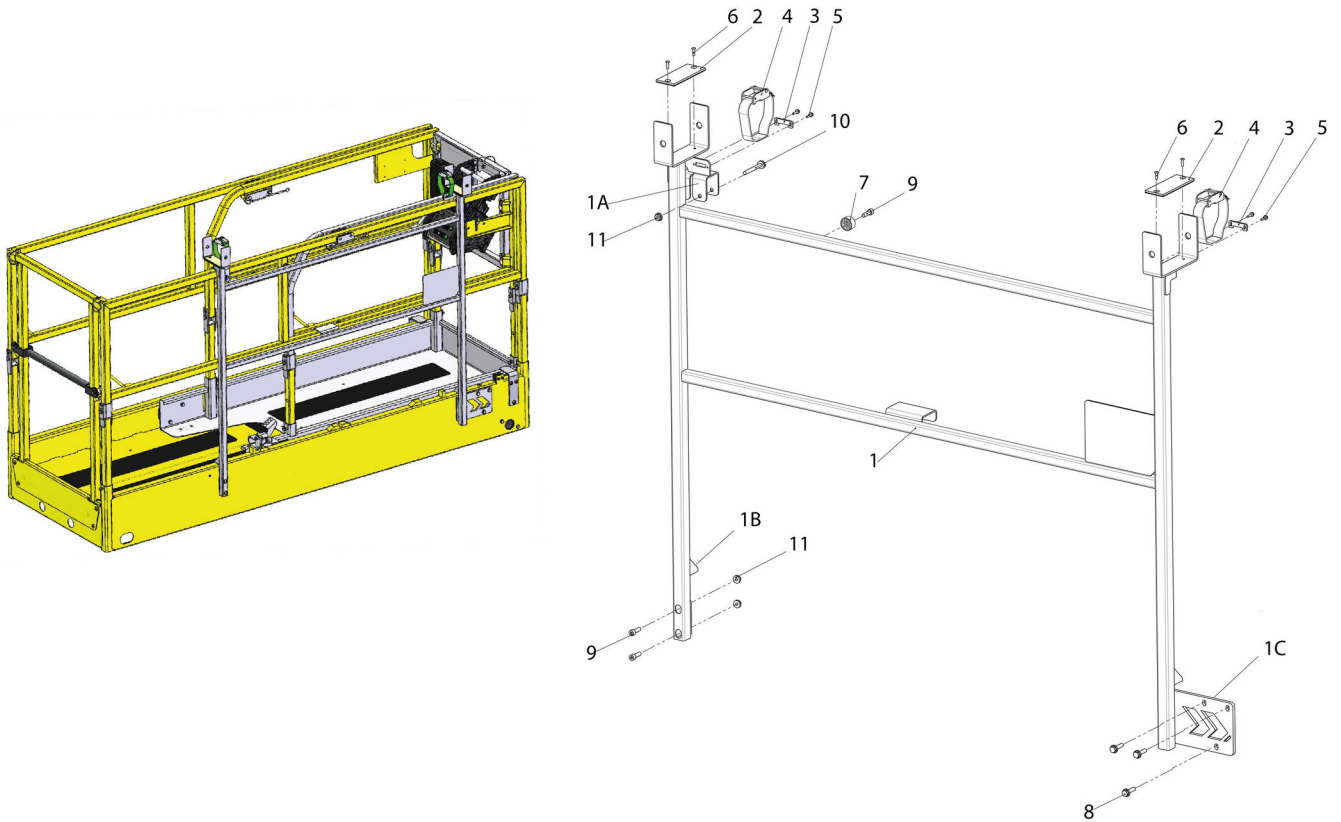

Marking	Description
1 - 1A - 1B - 1C	Carrier
2	Support protection
3	Fastening plate
4	Strap
5	Fastening screw
6	Pop Rivet
7	Wear pad
8	Fastening screw
9	Fastening screw
10	Fastening screw
11	Nut

- Straddle the support pipes (1, 1A, 1B) and (1C) on the structure of the fixed or folding guard rails.
- Fasten the support using the screw (10).
- Tighten the screws (8) (9) and the nuts (11) to the recommended torque.

N.B.-:TORQUE REQUIREMENTS : 22 NM (16 FT LBS)

- Pre-operation test : Place and secure the load of 70 kg (154 lbs) max. on the cradle. Ensure that the cradle can support the load and that there is no visual structural damage.

E - General Specifications

5.2.7 Specific decals

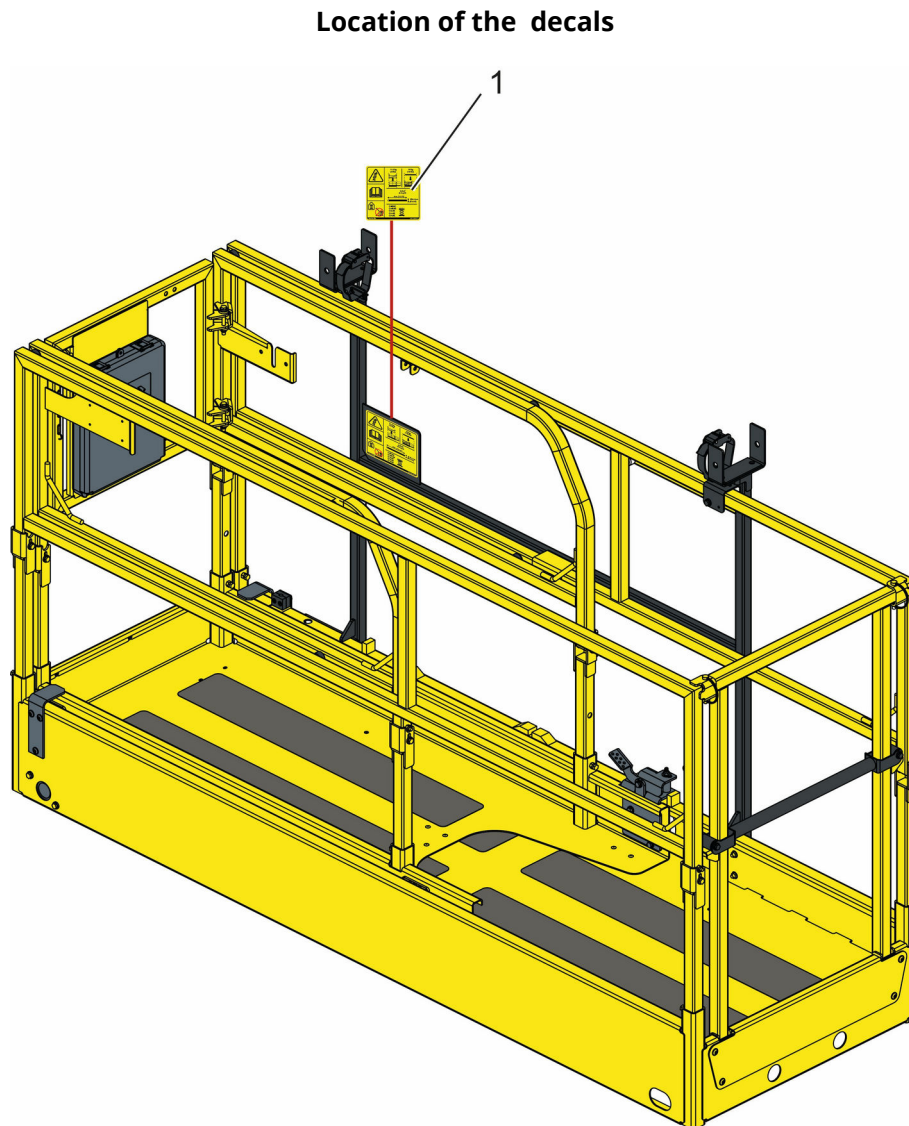

Marking	Description	Quantity	Part number
1	Risk of overturning	1	4001194340

5.3 Panel carrier

5.3.1 Description

This attachment is an assembly designed to transport panels. The assembly comprises of a tray that extends along the length of the floor. The panel(s) should be placed in the tray and secured to the guard rail with a strap (not supplied).

E - General Specifications

5.3.2 Characteristics

Specifications	SI	Imp.
Weight of the carrier	8 kg	18 lbs
Maximum allowable weight of the panels on the carrier	70 kg	154 lbs
Maximum load surface	4,32 m ² (L 3,6 m x H 1,2 m)	46.5 sq.ft (L 11 ft 8 in x H 4 ft)
Maximum wind speed allowed	0 m/s - 0 km/h	0 mph

5.3.3 Safety precautions



- Please read and assimilate the instructions before using the attachment.
- This attachment is designed for transporting panels. Do not use this attachment for transporting other types of load.
- Do not suspend loads.
- Centre the panel(s) on the platform.
- Secure the panel in place with the use of strap.
- Do not overload the attachment and ensure that the panels are secured with straps.
- Do not exceed the maximum allowable platform capacity. The combined weight of the attachment, load, the occupants, the tools and any other equipment must not exceed the maximum allowable platform capacity.
- When maneuvering, ensure you maintain a safe distance between the load and the obstacles in the work environment.



It is prohibited to use this option outdoors (Wind load on the machine—Loss of machine stability) .

5.3.4 Pre-operation inspection



- Check that the cradle has no cracks or other damage.
- Check that the cradle is correctly installed and secured to the platform (Ensure fastening screws are tightened and pins correctly positioned) .
- Check that the information decal is present on the cradle and is legible.
- Check that the strap(s) is(are)not twisted or torn.
- Check that the position of the load and attachment is not obstructing access to the platform or the controls.
- Check that the position of the attachment and the load is not reducing visibility during maneuvers in the work environment.

5.3.5 Operation

- Position and center the load to rest on the cradle.
- Securely attach the load on the cradle with straps (not supplied) .

E - General Specifications

Strapping example(s)



5.3.6 Disassembly - Assembly

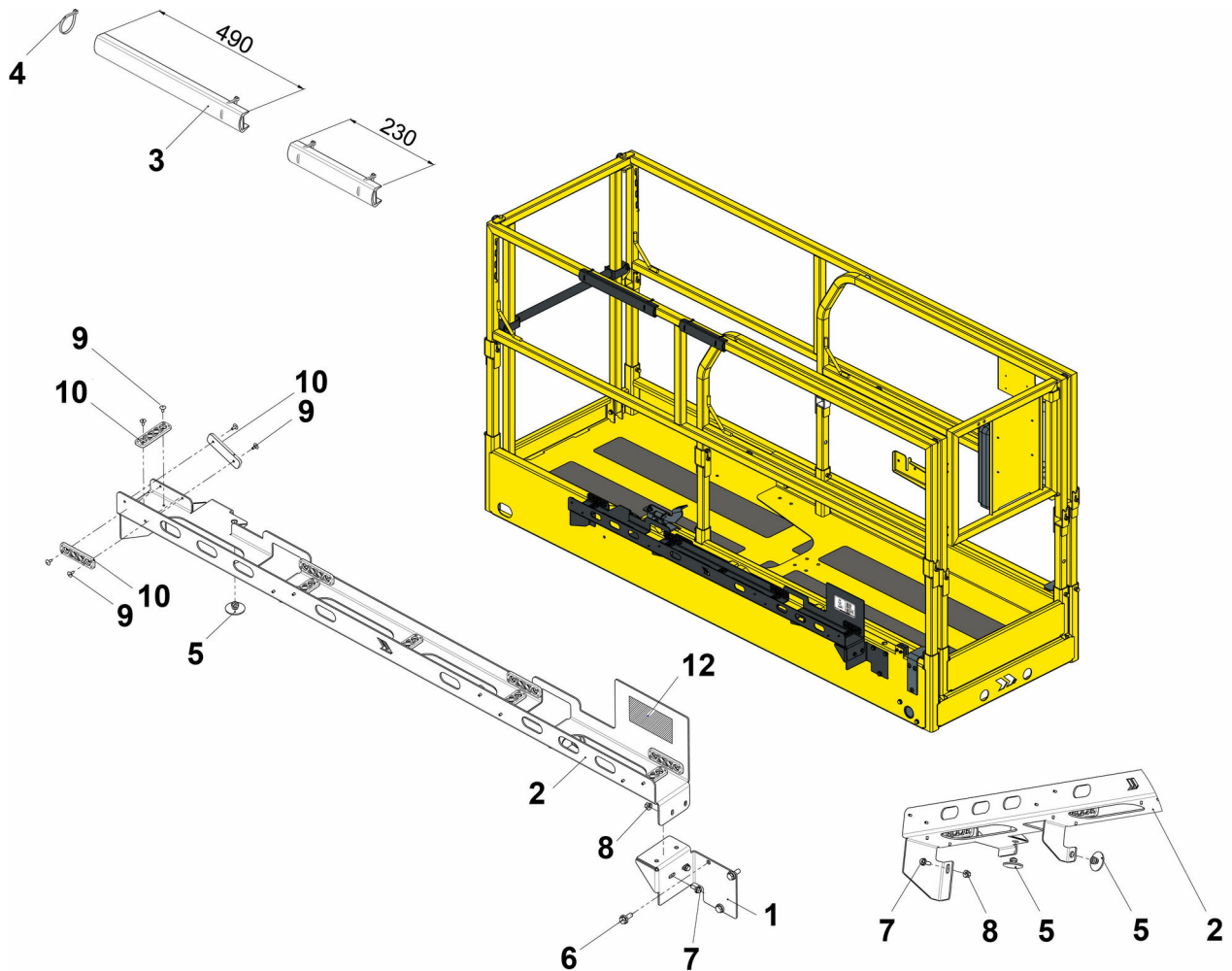

E - General Specifications

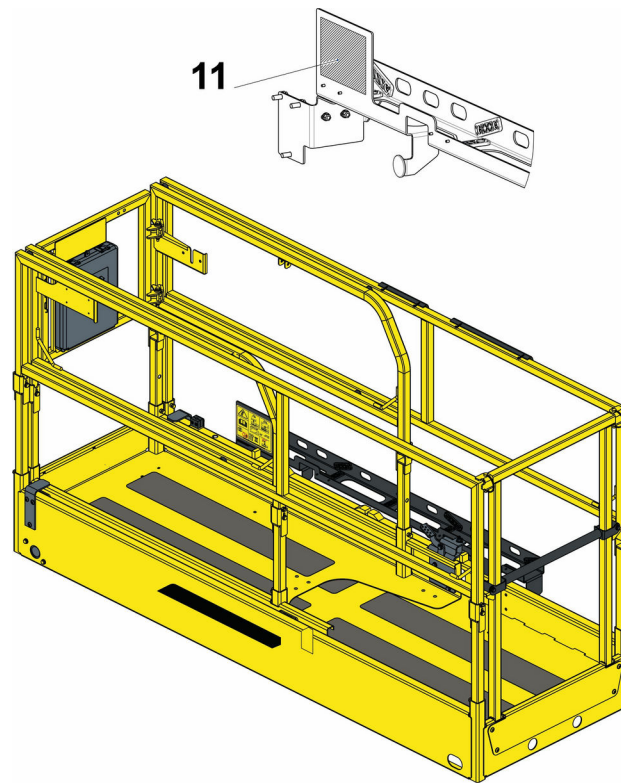

Marking	Description
1	Sheet metal support
2	Sheet metal support
3	Bumper
4	Clamp
5	Stop
6	Screw
7	Screw
8	Nut
9	Rivet
10	Protection pad
11	Decal
1	Decal

1. Position the sheet metal support (2) against the sheet metal support (1). Tighten the screws (7) and the nuts (8) to the recommended torque.
2. Place the protection pads (10), the rivets (9) and the stops (5).
3. After checking that the decal is on the cradle, position the sheet metal support (1) on the outside of the guardrail on the side of the control box.
4. Tighten the screw (7) and the nut (8) to the recommended torque. Tighten the screws (6) to the recommended torque.

E - General Specifications

5. Position the bumpers (3) and fasten with clamps (4).

N.B.-:TORQUE REQUIREMENTS : 10 NM (7 LBS/FT) FOR M6 AND 22 NM (16 LBS/FT) FOR M8.

- Pre-operation test : Place and secure the load of 70 kg (154 lbs) max. on the cradle. Ensure that the cradle can support the load and that there is no visual structural damage.

5.3.7 Specific decals

Location of the decals

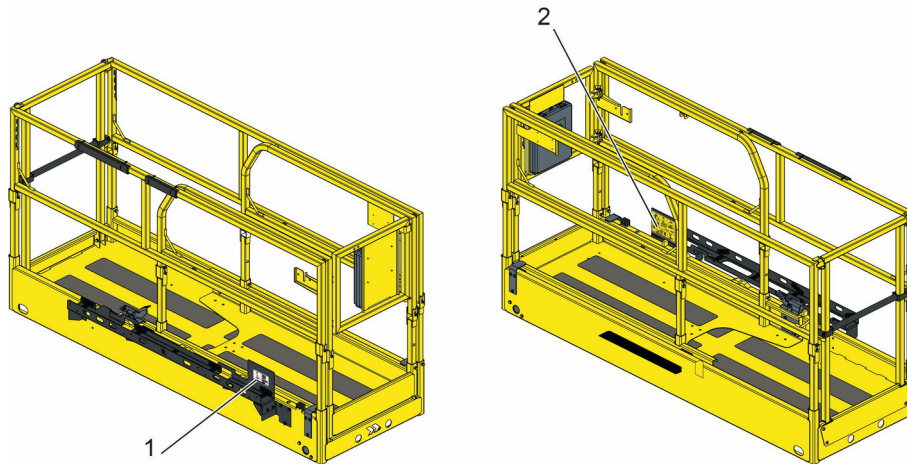

Marking	Description	Quantity	Part number
1	Information	1	4001199540
2	Risk of overturning	1	4001199550

5.4 SGS - SECONDARY GUARDING SYSTEM

5.4.1 Foreword

The SGS is a secondary protection system that senses the position and movement of the operator near the platform control box and authorizes or limits the movements of the machine.

It can reduce the risk of crushing and incidents when working at height, in a confined space.



This device does not excuse the user from their responsibilities when manoeuvring the machine. In particular, they must

- Be trained in the general use of aerial work platforms.
- Be trained in the specific use of the machine referred to in this manual.
- Apply all of the safety rules for using the machine, which are indicated in this machine user manual.
- Ensure that the machine used is adapted to the work to be carried out.
- Take the necessary measures to secure the work environment, particularly when working in confined spaces (Space where machine or operator movements are limited by obstacles, requiring operator vigilance in order to prevent a risk of crushing.) .
- Remain vigilant to machine movements and their work environment.



The SGS is a system that uses voice synthesis technologies. The system's language must correspond to the official language of the country in which the machine is used. It is the owner's responsibility to ensure that the language corresponds to the country in which the machine is used. If required, contact HAULOTTE Services® to update the system. Available languages : French,English,Spanish,Italian,German,Romanian,Portuguese,Korean.

5.4.2 Safety precautions

- Read and understand the safety guidelines set out in this machine user manual.

E - General Specifications

- Perform the pre-use checks below.
- Do not use the system as a support. (coat, tools, others) .
- Do not use the system as a handle.
- Do not obstruct the SGS sensor.



- The SGS is not operational during a drive movement when the machine is in transport position. The machine's stopping time at high speed is not compatible with the system's reaction time.
- The system is active when in the raised (lifting) position and when in reverse.
- It is therefore inactive in the lowered position and in the forward drive position.

5.4.3 Familiarization

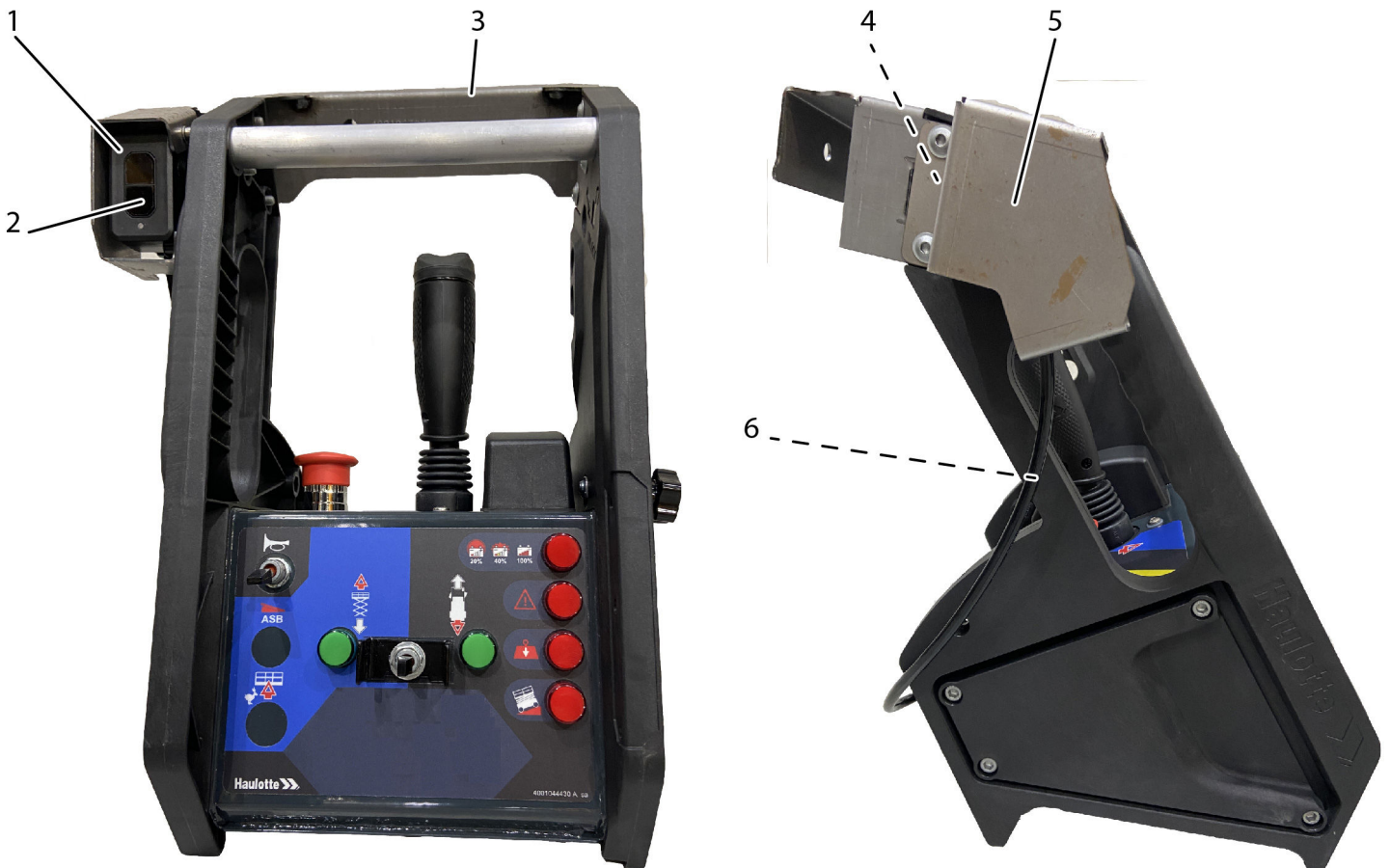

Marking	Description
1	Sensor SGS+Sensor protection film
2	Indicator light ( Summary of the indicator states)
3	Platform control box (Platform)
4	Loudspeaker
5	Protective plate
6	Joystick activation control

E - General Specifications





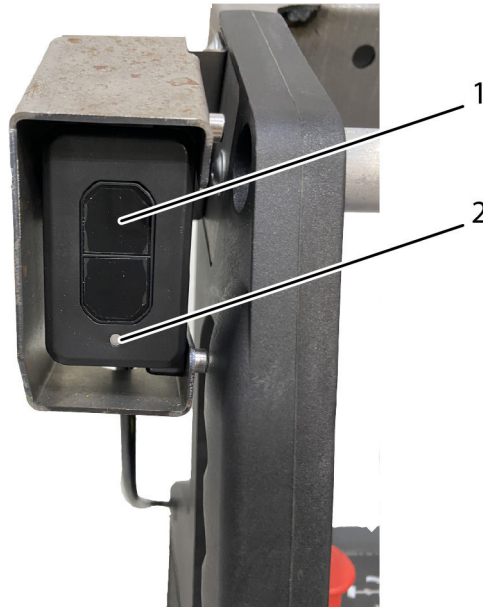

5.4.4 How the system works

SGS sensor details



E - General Specifications

Summary of the indicator states

Icon	Description
	Indicator not illuminated <ul style="list-style-type: none"> - The system is inactive. Operator position monitoring is not operational - LED failure
	Flashing green indicator <ul style="list-style-type: none"> - Operator position monitoring available - No aerial work platform movement in progress
	Steady green indicator light <ul style="list-style-type: none"> - Operator position monitoring active - Controlled movement (aerial work platform elevation, chassis movement)
	Flashing orange indicator light <ul style="list-style-type: none"> - SGS system fault. Speed is reduced.
	Steady orange indicator light <ul style="list-style-type: none"> - Speed is reduced : <ul style="list-style-type: none"> • Operator monitoring inactive due to poor positioning at the beginning of movement. • Or the sensor is obstructed
	Flashing red indicator light <ul style="list-style-type: none"> - A risk of crushing has been detected (Operator too close to the sensor or outside of the detection zone)

E - General Specifications

5.4.5 Inspecting the system before using the machine

Before using the machine each time, ensure that the the system is in a good state of cleanliness and that it is operating correctly.



- Never use the machine if you observe a system malfunction.
- If you observe a fault during the inspection, the machine must be tagged and taken out of service.
- Do not operate the machine until all anomalies are corrected and it has been declared safe for operation.

Step	Action
1	Start the machine from the keypad (C188).
2	Select the upper console by pressing PLTFM button.
3	Get into the work platform.
4	Ensure that the SGS is clean and free from dust, water, paint, silicone or any other dirt that could affect its operation. Replace the sensor's protective film, if required.
5	Machine in transport position :
6	- The operator should face the sensor.
7	- Select the 'raise' movement by pressing the selector (112) : - • The sensor's green light flashes.
8	- Press the enable switch (123) : - • The "Lift" message is heard.
9	- Lift the platform several centimetres.
10	- During the movement, put your left hand on the sensor. The SGS detects a risk of crushing : - • The lifting movement is interrupted. - • The sensor's red light flashes. - • The "Stop movement" message is heard. - • The horn is heard after several seconds.
11	- Press the enable switch (123) to return to normal operation : • Set the joystick (108) to neutral. • Release the enable switch (123).

E - General Specifications

5.4.6 Operating and using the SGS

	SGS status	Operator position	Drive speed (Forwards drive/Reverse drive/Steering)	Lifting speed (Platform elevation/lowering)
Machine in transport position	Inactive	Not detected	No limitation	N/A
Machine lifting	Active	Detected	Micro speed 	No limitation
		Not detected	Speed reduced (Lower than micro speed)	Speed reduced (Lower than micro speed)

Operation if risk of crushing is detected

	Movement in progress	Indicator light status	Buzzer status	Beacon status	Movement allowed
Elevation	Locked	Flashing red	Audible	Active	- Forwards drive - Reverse drive - Lowering
Reverse drive	Locked	Flashing red	Audible	Active	- Forwards drive - Lowering

5.4.7 Evacuation procedure if the operator is crushed or loses consciousness

N.B.-PLEASE REFER TO PARAGRAPH  D 4.2 - TO RESCUE OPERATOR IN PLATFORM.

Procedure :

1. On the keypad (C188), press PLTFM button to energize the ground control box. The platform box controls are de-energized.
2. Lower the platform from the ground control box.
3. Lower the platform using the platform raising/lowering selector (1) while simultaneously pressing and maintaining the Enable Switch (9).
4. Release it to halt lowering.

If a safety systems do not allow normal movement from the ground control box, lower the basket (or platform) using the T-handle on the chassis.



Once rescue operations are complete, write an incident report.

N.B.-USE THE T-HANDLE (C107) SHOULD THE GROUND CONTROL BOX NOT BE ACCESSIBLE.

F - Maintenance

1	General.....	3
2	Maintenance Schedule.....	4
3	Inspection program.....	5
3.1	General program.....	5
3.2	Daily inspection.....	5
3.3	Periodic inspection.....	5
3.4	Reinforced inspection.....	5
3.5	Major inspection.....	6
4	Repairs and adjustments.....	7

1 General

As an owner and/or operator of Haulotte equipment, your Safety is of utmost importance to HAULOTTE®, which is why HAULOTTE® places such a high priority on product safety.

INSPECTIONS are not only required by HAULOTTE®, but may also be required by industry standards and/or local regulations.

To ensure your equipment continues to achieve the level of performance set in the factory, it is important to maintain it regularly. We remind you that it is strictly forbidden to make any modifications. Regular and timely inspections will reduce equipment down time as well as prevent possible injury.

N.B.-:DO NOT OPERATE UNLESS YOU ARE FAMILIAR AND TRAINED IN THE PRINCIPLES OF SAFE MACHINE OPERATION.

Overview :

- Walk-around inspections take only a few minutes at the beginning and end of each shift – one of the best ways to prevent mechanical problems and safety hazards.

What to Do :

- Use your senses: sight, smell, hearing and touch.

Frequency :

- Check your machine periodically during your entire workday.
- Make sure to do your inspection the same way every time.
- Complete one of these inspections at the start and end of each shift.

N.B.-:IF DAMAGE OR UNAUTHORIZED MODIFICATIONS ARE DISCOVERED, THE MACHINE MUST BE REMOVED FROM SERVICE UNTIL REPAIRS ARE MADE BY A QUALIFIED SERVICE TECHNICIAN.

It is the owner's responsibility to ensure the required maintenance as recommended by Haulotte is completed prior to the operation of the machine.

If regular maintenance is not carried out, this may :

- Void the warranty.
- Cause machine malfunction.
- Reduce machine reliability and shorten its service life.
- Jeopardize operator safety.

HAULOTTE Services® technicians are specially trained to carry out extensive repairs, interventions or adjustments on the safety systems or elements of HAULOTTE® machines. They carry genuine HAULOTTE spare parts and tools as required, and also provide fully documented reports on all work completed.

The inspection and maintenance table, identifies the role and the responsibilities of each party in periodical machine maintenance.  C 3 - Inspection and Functional test.

2 Maintenance Schedule

This section provides the necessary information needed to place the machine in safe operation. In accordance with the regulations that are currently applicable, this machine is designed to have a 10 year life span in normal usage conditions. The life may be extended or reduced dependent on the severity of operating conditions, the machine condition itself and by conducting effective inspections and maintenance in addition to other external factors. There are a number of factors which can affect the design life including but not limited to, severity of operating conditions/routine maintenance which should be carried out in accordance with this manual.

Severity of operating conditions may require a reduction in time between maintenance periods. Machines that have been out of service or have not been in use for more than 3 months must undergo a periodic inspection before the machine is put back into service.

Maintenance must be carried out by a competent company or person familiar with mechanical procedures.

Maintenance operations performed must be recorded in a register / log book of the machine.

3 Inspection program

3.1 General program

The machine must be inspected on a regular basis at intervals of no less than once 1 per year. The purpose of the inspection is to detect any defect which could lead to an accident during routine use of the machine. Local standards and regulations may require more frequent inspections.

HAULOTTE® requires Reinforced and Major Inspections to be carried out on the product to extend its service life.

Inspections must be carried out by a competent company or person.

The inspection results must be recorded in the safety register or machine log book controlled and overseen by the company manager. This register or machine log book and the list of competent repair persons must be made available to the government work inspector and HAULOTTE Services®.

When	Person-in-charge	Stakeholder	What
Before sale	Owner (or renter)	Competent technician or qualified technician HAULOTTE Service®	Periodic inspection
Before rent	Owner (or renter)	Competent technician or qualified technician HAULOTTE Service®	Daily inspection
Before use or every change of user	Operator	Operator	Daily inspection
Annually (1 year)	Owner (or renter)	Competent technician or qualified technician HAULOTTE Service®	Periodic inspection
5 years	Owner (or renter)	Competent technician or qualified technician HAULOTTE Service®	Reinforced inspection
10 years	Owner (or renter)	Competent technician or qualified technician HAULOTTE Service®	Major inspection

3.2 Daily inspection

The Daily inspection includes a visual inspection, operational checks and testing of the safety systems. This must be conducted by the operator before using the machine.

This inspection is the responsibility of the user. Refer to  C 3.1 - Daily inspection.

3.3 Periodic inspection

The Periodic inspection is a thorough evaluation of the operation and safety features of the machine.

It must be conducted before the sale / resale of the machine and/or at least once every year.

Local regulations may have specific requirements on frequency, and content of inspections.

The severity of operating conditions may require frequent inspections.

This inspection is the responsibility of the owner, and inspections must be carried out by a competent company or person.

This inspection is in addition to the daily inspection.

This inspection should also be conducted after :

- Extensive dismantling and reassembly of major components.
- Repairs involving the machine's essential components.
- Any accident causing stress to the machine.

3.4 Reinforced inspection

The Reinforced inspection is a thorough evaluation of the machine's structural components, to ensure proper functionality of the machine.

F - Maintenance

This evaluation must occur at a frequency of 5000 hours or every 5 years.

This inspection is the responsibility of the owner, and it must be conducted by a HAULOTTE Services® technician or by a competent company or person.

This inspection includes

- Daily inspection
- Periodic inspection

N.B.-:REFER TO THE MAINTENANCE MANUAL FOR DETAILS.

3.5 Major inspection

The Major inspection is a thorough evaluation of the machine's integrity and proper functioning; after a normal service life of 10 years.

This evaluation must take place after 10 years of operation and then repeated every 5 years thereafter.

The severity of operating conditions may require frequent inspections.

This inspection is the responsibility of the owner, and it must be conducted by a HAULOTTE Services® technician or by a competent company or person.

This inspection includes :

- Daily inspection
- Periodic inspection
- Reinforced inspection

N.B.-:REFER TO THE MAINTENANCE MANUAL FOR DETAILS.

4 Repairs and adjustments

Extensive repairs, interventions or adjustments on the safety systems or components must be performed by a HAULOTTE Services® technician. Use original spare parts and components only.

N.B.-HAULOTTE SERVICES® TECHNICIANS ARE TRAINED PROFESSIONALS TO PERFORM EXTENSIVE REPAIRS, INTERVENTIONS AND ADJUSTMENTS ON THE SAFETY SYSTEMS OR COMPONENTS OF HAULOTTE® MACHINES. THE TECHNICIAN CARRIES GENUINE HAULOTTE® SPARE PARTS AND TOOLS AS REQUIRED, AND ALSO PROVIDES FULLY DOCUMENTED REPORTS ON ALL WORK COMPLETED.

HAULOTTE Services® will not take responsibility for any outcomes resulting from inferior services or repairs performed by other unauthorised personnel.

HAULOTTE® reminds that NO modifications SHALL be carried out without the written permission of HAULOTTE®.

Any unauthorised repairs/modifications will void HAULOTTE® warranty.

To check for safety campaigns, consult our website : www.haulotte.com



N.B.-WHEN DISPOSING OR SCRAPPING THIS MACHINE, PLEASE CONSIDER APPROPRIATE METHODS OF RECYCLING. ANY ITEMS THAT REQUIRE SPECIFIC DISPOSAL ARE LISTED WITH INSTRUCTIONS IN THE MAINTENANCE MANUAL.

G - Other information

1	Conditions of warranty.....	3
2	Subsidiary contact information.....	4
2.1	California warning.....	5

G - Other information

1 Conditions of warranty

Our warranty conditions and extension contracts are now available on the websites of our sales network :
www.haulotte.com

G - Other information







2 Subsidiary contact information

	<p>HAULOTTE FRANCE PARC DES LUMIERES 601 RUE NICEPHORE NIEPCE 69800 SAINT-PIERRE TECHNICAL Department: +33 (0)820 200 089 SPARE PARTS : +33 (0)820 205 344 FAX : +33 (0)4 72 88 01 43 E-mail : haulottefrance@haulotte.com www.haulotte.fr</p>		<p>HAULOTTE ITALIA VIA LOMBARDIA 15 20098 SAN GIULIANO MILANESE (MI) TEL: +39 02 98 97 01 FAX: +39 02 9897 01 25 E-mail : haulotteitalia@haulotte.com www.haulotte.it</p>		<p>HAULOTTE INDIA Unit No. 1205, 12th floor, Bhumiraj Costarica, Plot No. 1&2, Sector 18, Palm Beach Road, Sanpada, Navi Mumbai- 400 705 Maharashtra, INDIA Tel. : +91 22 66739531 to 35 E-mail : hlindia@haulotte.com www.haulotte.in</p>
	<p>HAULOTTE HUBARBEITSBÜHNEN GmbH Ehrenkirchener Strasse 2 D-79427 ESCHBACH TEL : +49 (0) 7634 50 67 - 0 FAX : +49 (0) 7634 50 67 - 119 E-mail : adv-gmbh@haulotte.com www.haulotte.de</p>		<p>HAULOTTE VOSTOK 61A, bld.1, RYABINOVAYA STREET 121471 MOSCOW RUSSIA TEL/FAX : +7 495 221 53 02 / 03 E-mail : salesrus@haulotte.com www.haulottevostok.ru</p>		<p>HAULOTTE DO BRASIL Av. Alameda Caiapós, 589 CEP: 06460-110 – TAMBORE BARUERI – SAO PAULO – BRASIL TEL : +55 11 4196 4300 FAX : +55 11 4196 4316 E-mail : haulottebrasil@haulotte.com www.haulotte.com.br</p>
	<p>HAULOTTE IBERICA C/ARGENTINA Nº 13 - P.I. LA GARENA 28806 ALCALA DE HENARES MADRID TEL : +34 902 886 455 TEL SAT : +34 902 886 444 FAX : +34 911 341 844 E-mail : iberica@haulotte.com www.haulotte.es</p>		<p>HAULOTTE POLSKA Sp. z o.o. UL. GRANICZNA 22 05-090 RASZYN - JANKI TEL : +48 22 720 08 80 FAX : +48 22 720 35 06 E-mail : haulottepolska@haulotte.com www.haulotte.pl</p>		<p>HAULOTTE MÉXICO, S.A. de C.V. Calle 40 SUR ESQUINA 13 ESTE No. S/N Colonia CIVAC, JUITEPEC, MORELOS CP 62578 México TEL : +52 77 7321 7923 FAX : +52 77 7516 8234 E-mail : haulotte.mexico@haulotte.com www.haulotte.com.mx</p>
	<p>HAULOTTE in JAPAN SBJ ShinOsaka BLDG 3F 4-6-5 Nishinakajima Yodogawa-ku, Osaka, JAPAN, Post Code: 532-0011 TEL : +81 6 6795 9008 FAX : +81 6 6795 9009 www.haulotte.com</p>		<p>HAULOTTE SINGAPORE Pte Ltd. No.26 CHANGI NORTH WAY, SINGAPORE 498812 Parts and service Hotline: +65 6546 6150 FAX : +65 6536 3969 E-mail : haulotteasia@haulotte.com www.haulotte.sg</p>		<p>HAULOTTE MIDDLE EAST FZE PO BOX 293881 Dubai Airport Free Zone DUBAI United Arab Emirates TEL : +971 (0)4 299 77 35 FAX : +971 (0) 4 299 60 28 E-mail : haulottemiddle-east@haulotte.com www.haulotte.ae</p>
	<p>HAULOTTE SCANDINAVIA AB Taljegårdsgatan 12 431 53 Mölndal SWEDEN TEL : +46 31 744 32 90 FAX : +46 31 744 32 99 E-mail : info@se.haulotte.com spares@se.haulotte.com www.haulotte.se</p>		<p>HAULOTTE TRADING (SHANGHAI) Co. Ltd. Room 606A, Tower 3, Ronshine Sunkwan Center Lane 77, Sunkun Road MINHANG DISTRICT SHANGHAI 201105 CHINA TEL : +86 21 6442 6607 FAX : +86 21 6442 6619 E-mail : haulotteshanghai@haulotte.com www.haulotte.cn</p>		<p>HAULOTTE ARGENTINA Ruta Panamericana Km. 34,300 (Ramal A Escobar) 1615 Gran Bourg (Provincia de Buenos Aires) Argentina TEL : +54 33 27 445991 FAX : +54 33 27 452191 E-mail : haulotteargentina@haulotte.com www.haulotte.com.ar</p>
	<p>HAULOTTE UK Ltd 1 Gravely Way Four Ashes Wolverhampton WV10 7GW ENGLAND TEL : +44 (0)1216 199753 FAX : +44 (0)1952 292758 E-mail : salesuk@haulotte.com www.haulotte.co.uk</p>		<p>HAULOTTE GROUP / BILJAX 125 TAYLOR PARKWAY ARCHBOLD, OH 43502 - USA TEL : +1 419 445 8915 FAX : +1 419 445 0367 Toll free : +1 800 537 0540 E-mail : sales@us.haulotte.com www.haulotte-usa.com</p>		<p>HAULOTTE NORTH AMERICA 3409 Chandler Creek Rd. VIRGINIA BEACH, VA 23453 - USA TEL : +1 757 689 2146 FAX : +1 757 689 2175 Toll free : +1 800 537 0540 E-mail : sales@us.haulotte.com www.haulotte-usa.com</p>
	<p>HAULOTTE NETHERLANDS BV Koopvaardijweg 26 4906 CV OOSTERHOUT - Nederland TEL : +31 (0) 162 670 707 FAX : +31 (0) 162 670 710 E-mail info@haulotte.nl www.haulotte.nl</p>		<p>HAULOTTE AUSTRALIA PTY Ltd 51 Port Link Drive DANDENONG - VIC - 3175 TEL : 1 300 207 683 FAX : +61 (0)3 9792 1011 E-mail : sales@haulotte.com.au www.haulotte.com.au</p>		<p>HAULOTTE CHILE Panamerica Norte Altura Km 21,5 Colina (Cruce c/Lo Pinto) Santiago (RM) TEL : + 562 2 3727630 E-mail : haulotte-chile@haulotte.com www.haulotte-chile.com</p>

G - Other information

2.1 California warning

For the US destined machines (ANSI and CSA standards)

<p>CALIFORNIA</p>  <p>Proposition 65 Warning</p> <p>Operating, servicing and maintaining a passenger vehicle or off-road vehicle can expose you to chemicals including engine exhaust, carbon monoxide, phthalates, and lead, which are known to the State of California to cause cancer and birth defects or other reproductive harm. To minimize exposure, avoid breathing exhaust, do not idle the engine except as necessary, service your vehicle in a well-ventilated area and wear gloves or wash your hands frequently when servicing your vehicle.</p> <p>For more information go to  www.P65Warnings.ca.gov/passenger-vehicle</p>
<p>CALIFORNIE</p>  <p>Avertissement de la Proposition 65</p> <p>L'exploitation, l'entretien et la maintenance d'un véhicule de tourisme ou d'un véhicule tout-terrain peuvent vous exposer à des produits chimiques, y compris les gaz d'échappement, le monoxyde de carbone, les phthalates et le plomb, identifiés par l'État de Californie comme pouvant causer le cancer et des malformations congénitales ou autres effets nocifs sur la reproduction. Pour limiter toute exposition: évitez de respirer les gaz d'échappement, ne laissez pas tourner le moteur au ralenti sauf si nécessaire, faites l'entretien du véhicule dans une zone bien aérée et portez des gants ou lavez vous fréquemment les mains lors de cette opération.</p> <p>Pour de plus amples informations, consulter  www.P65Warnings.ca.gov/passenger-vehicle</p>
<p>CALIFORNIA</p>  <p>Advertencia de la Proposición 65</p> <p>Operar, dar servicio y mantenimiento a un vehículo de pasajeros o vehículo todo terreno puede exponerle a químicos incluyendo gases del escape, monóxido de carbono, ftalatos y plomo, los cuales son conocidos por el Estado de California como causantes de cáncer y defectos de nacimiento u otros daños reproductivos. Para minimizar la exposición, evite respirar los gases del escape, no encienda el motor excepto si es necesario, dé servicio a su vehículo en un área bien ventilada y utilice guantes o lave sus manos frecuentemente cuando dé servicio a su vehículo.</p> <p>Para mayor información visite  www.P65Warnings.ca.gov/passenger-vehicle</p>

G - Other information

For electric (battery operated) machines

CALIFORNIA



Proposition 65 Warning

Battery posts, terminals and related accessories contain lead and lead compounds, chemicals known to the State of California to cause cancer and reproductive harm. Batteries also contain other chemicals known to the State of California to cause cancer.

WASH HANDS AFTER HANDLING.

For more information go to  www.P65Warnings.ca.gov

CALIFORNIE



Avertissement de la Proposition 65

Les batteries, les bornes et autres accessoires contiennent du plomb et des composés à base de plomb, agents chimiques identifiés par l'État de Californie comme pouvant provoquer le cancer et des effets nocifs sur la reproduction. Les batteries contiennent également d'autres agents chimiques identifiés par l'Etat de Californie comme pouvant provoquer le cancer.

SE LAVER LES MAINS APRES MANIPULATION.

Pour de plus amples informations, consulter  www.P65Warnings.ca.gov

CALIFORNIA



Advertencia de la Proposición 65

Los bornes, los terminales y los accesorios de las baterías contienen plomo y compuestos de plomo, químicos conocidos por el Estado de California como causantes de cáncer y daños reproductivos. Las baterías también contienen otros químicos conocidos por el Estado de California como causantes de cáncer.

LAVESE LAS MANOS DESPUES DE MANIPULARLOS.

Para mayor información visite  www.P65Warnings.ca.gov

1 Intervention register..... 3

1 Intervention register

The intervention register keeps a record of maintenance and repair work carried out inside or outside the maintenance programme.

N.B.:-IN THE CASE OF A HAULOTTE SERVICES® INTERVENTION, THE QUALIFIED TECHNICIAN MUST INDICATE THE HAULOTTE SERVICES® INTERVENTION NUMBER.

Date	Type of intervention	Number of hours	Intervenor	intervention number



MISE A JOUR

Suite à l'évolution de nos machines,
veuillez prendre en compte les pages suivantes pour
les manuels joints à votre machine.

UPDATE

*Further to the evolution of our machines,
please take into account the following pages for the
manuals delivered with your machine.*

6.4 Declaration of conformity



The CE declarations of conformity only apply to machines that have been approved and commissioned within the European Community (EC).

6.4.1 Declaration of conformity - All machines



The UKCA declarations of conformity only apply to machines that have been approved and commissioned within the United Kingdom (UK).

Declaration of conformity - UKCA and CE standards



UKCA / EC DECLARATION OF CONFORMITY

HAULOTTE Factory



Declares under our own responsibility that the machine described below :

Mobile Elevating Work Platform

Commercial name
Type
Serial number

Commercial name of the concerned machine
Model type of concerned machine
Serial number of the machine

Conforms with provisions of the Regulations listed below :

<p>CE</p> <p>EC Machinery Directive 2006/42/CE EC Directive electromagnetic compatibility 2014/30/EU EU RED Directive on radio equipment (if machine equipped) 2014/53/UE</p>	<p>UKCA</p> <p>Supply of Machinery (safety) 2008 SI2008/1597 amended SI2011/1043/2157 2019/696 Electromagnetic compatibility 2016 SI 2016/1091 amended SI 2017/1206, 2019/696 Radio equipment (if machinery equipped) 2017</p>
--	---

This machine has been type examined by :

<p>Name of the Authorized body :</p>	<p>Name of the Approved body :</p>
--------------------------------------	------------------------------------

<p>Certificate number :</p>	<p>Certificate number :</p>
-----------------------------	-----------------------------

<p>Harmonized standard(s) used as reference(s) : EN280</p>	<p>Designed standard(s) used as reference(s) : BS EN280</p>
--	---

Person authorised to compile the technical file :

<p>HAULOTTE GROUP Compliance Manager RUE EMILE ZOLA CS 30045 42420 LORETTE FRANCE</p>	<p>HAULOTTE UK Ltd General Manager UK and Ireland Unit 1 Gravelly Way, Four Ashes Wolverhampton, West Midlands WV10 7GW ENGLAND</p>
--	---

Name and Signature
Division Director

Date and place



77736583019230017NVZ2691PF-02
 NVZ26910H-CE-UKCA-V2.0.5

6.4.2 Declaration of conformity - Electric platforms

Declaration of conformity - CE standard



**DECLARATION CE DE CONFORMITE
 (EC DECLARATION OF CONFORMITY)**



<p>Fabricant et personne autorisée à constituer le dossier technique : <i>(Manufacturer and the person authorised to compile the technical file.)</i></p> <p>HAULOTTE GROUP</p> <p>Adresse du site de production <i>(Address of the Division)</i></p> <p>en conformité avec le modèle type <i>(In compliance with the Model Type)</i></p> <p>Nom commercial <i>(Commercial name)</i></p> <p>Numéro de série <i>(Serial number)</i></p> <p>Organisme notifié <i>(Notified body)</i></p> <p>Numéro de certificat <i>(Certificate number)</i></p> <p>Charge maximale d'utilisation <i>(Rated capacity)</i></p>	<p>Compliance & Regulation Director HAULOTTE GROUP S.A. RUE EMILE ZOLA 42420 LORETTE FRANCE</p> <p>Nacelle élévatrice de personnel <i>(Mobile Elevating Work Platform)</i></p> <p>Modèle type de la machine concernée <i>(Type model of the concerned machine)</i></p> <p>Nom commercial de la machine concernée <i>(Commercial name of the concerned machine)</i></p> <p>Numéro de série de la machine concernée <i>(Serial number of the machine)</i></p> <p>Nom et adresse de l'organisme notifié <i>(Name and address of notified body)</i></p> <p>Numéro de certificat du type de machine <i>(Certificate number of machine)</i></p> <p>Charge maximale d'utilisation de la machine concernée <i>(Rated capacity of concerned machine)</i></p>
--	--

**Nous déclarons que cette machine est conforme aux dispositions des Directives suivantes
 (We hereby declare that this machine conforms with all the relevant provisions of the Directives listed below)**

<p>Directive CE Machine <i>(EC Machinery Directive)</i></p> <p>Se conforme aux principales exigences de la norme harmonisée <i>(This machine also fulfils the principles of the harmonised standard)</i></p> <p>Directive CE concernant la compatibilité électromagnétique <i>(EC Directive on electromagnetic compatibility)</i></p> <p>Directive CE RED concernant les équipements radioélectriques (si machine équipée) <i>(RED EC Directive on radio electrical equipment (if machine equipped))</i></p>	<p>2006/42/CE</p> <p>EN280</p> <p>2014/30/EU</p> <p>2014/53/EU</p>
--	--

Cette déclaration porte exclusivement sur la machine dans l'état où elle a été placée sur le marché
(This declaration relates exclusively to the machinery in the state in which it was placed on the market)

Toute modification de la machine décrite ci-dessus a pour effet d'invalider cette déclaration
(Any modification to the above described machine violates the validity of this declaration)

<p>Nom et signature du Directeur du site de production <i>(Name and signature of the Division Director)</i></p>	<p>Lieu <i>(Place)</i></p> <p>Date <i>(Date)</i></p>
--	--

haulotte.com

C - Pre-operation inspection

In this case, fully lower the platform and reposition the machine on level ground before raising the platform again.

To check the tilt sensor at ground level, perform the following steps:

Platform control box

Step	Action
1	Put the machine in stowed position.
2	Position the machine on an incline that is greater than the maximum permitted incline ( B 3 - Technical specifications) .
3	Check that the tilt indicator is on (27).
4	Raise the platform until it reaches automatic cut-out (< 3,50 m (11 ft 6 in)).
5	Buzzers at ground and platform will beep.

4.8 Braking test



Check that there are no hazards in the test area:

- Position the machine on a flat and firm surface, clear of obstructions (beware of power lines).
- Ensure that there is sufficient distance to stop the machine in complete safety.
- Position the steered wheels so that they are straight.
- To set up a beaconing of safety around the test area.

Platform control box





Step	Action
1	Pull both E-Stop buttons; at ground box and at platform box.
2	Turn the ground control box selector key to platform control box position.
3	Select low drive speed , then slowly move the drive joystick.
4	Drive the machine forward in low speed on a ramp inclined at less than the maximum authorized slope.
5	Release joystick.
6	The machine comes to a complete stop. Keep the machine immobilized for 5 seconds.
7	Check the ability of the brakes to keep the machine immobilized. The machine must remain immobile.

4.9 Overload test

The overload system is an essential part of machine safety. The following tests must be performed periodically-

You will need:

C - Pre-operation inspection

	<ul style="list-style-type: none"> - Personal protective equipment - DO NOT OPERATE tag - Standard tool kit - Lifting equipment adapted and suitable for placing and removing the load from the platform - Load: <ul style="list-style-type: none"> • For CE / UKCA / ANSI / CSA / AS: 100% of the nominal load  Refer to section B - Technical specifications. • All except CE / UKCA / ANSI / CSA / AS: 120% of the nominal load  Refer to section B - Technical specifications. 		<ul style="list-style-type: none"> - Place barriers around the perimeter of the work area
	<p>1 person</p>		

Procedure:

Platform control box

Step	Action
1	Position the machine on a flat and firm surface, clear of obstructions (beware of power lines).
2	Put the machine in stowed position.
3	Mark out the work area (barriers, cones, marking tape).
4	Restrict access to the area (restricted access sign).
5	Place a do not operate tag at the start/stop switch location to inform personnel that the equipment is being worked on.
6	Push the machine to the location beneath where aerial working is required.
7	Start the machine.
8	Use an external weight lifting device to place 100% of the nominal weight in the center of the platform.
9	From the ground control box: Check that there is no overload alarm.
10	Remove the weight from the platform.
11	Use an external weight lifting device to place 120% of the nominal weight in the center of the platform.
12	Check the overload / fault indicator light is ON.
13	Check the overload alarm is displayed on the .
14	Remove all load from the platform.

4.10 Pothole protection system (Pothole protection)

The machine is equipped with a system to prevent overturning when moving - platform raised - in the event of a sudden change in the driving surface level (step, pothole, etc).

Located under the chassis, this device deploys automatically before the work platform leaves its transport position (extending structure folded).

4 Repairs and adjustments

Extensive repairs, interventions or adjustments on the safety systems or components must be performed by a HAULOTTE Services® technician. Use original spare parts and components only.

N.B.-HAULOTTE SERVICES® TECHNICIANS ARE TRAINED PROFESSIONALS TO PERFORM EXTENSIVE REPAIRS, INTERVENTIONS AND ADJUSTMENTS ON THE SAFETY SYSTEMS OR COMPONENTS OF HAULOTTE® MACHINES. THE TECHNICIAN CARRIES GENUINE HAULOTTE® SPARE PARTS AND TOOLS AS REQUIRED, AND ALSO PROVIDES FULLY DOCUMENTED REPORTS ON ALL WORK COMPLETED.

HAULOTTE Services® will not take responsibility for any outcomes resulting from inferior services or repairs performed by other unauthorised personnel.

HAULOTTE® reminds that NO modifications SHALL be carried out without the written permission of HAULOTTE®.

Any unauthorised repairs/modifications will void HAULOTTE® warranty.

To check for safety campaigns, consult our website: www.haulotte.com



N.B.-WHEN DISPOSING OR SCRAPPING THIS MACHINE, PLEASE CONSIDER APPROPRIATE METHODS OF RECYCLING. ANY ITEMS THAT REQUIRE SPECIFIC DISPOSAL ARE LISTED WITH INSTRUCTIONS IN THE MAINTENANCE MANUAL.

Données générales

D - Fiches machine

Procédure de test de freinageMS0004**1 Avertissement**

- Seul un technicien autorisé et qualifié peut intervenir sur les machines HAULOTTE®.
- L'utilisation de la présente fiche implique que son utilisateur soit formé sur ce type de matériel.
- Il est important que la personne intervenant sur la machine connaisse toutes les informations relatives à la sécurité contenues dans le manuel utilisateur.
- D'une manière générale, l'utilisateur doit se conformer aux obligations réglementaires en vigueur, notamment celles spécifiques au travail isolé, à la co-activité, à la manutention manuelle de charge...
- L'utilisateur doit avoir toutes les autorisations / habilitations nécessaires pour travailler (permis de feu...) et se conformer aux consignes de sécurité spécifiques au lieu d'intervention.
- Ne sont décrits dans cette fiche que les risques spécifiques liés aux activités propres au démontage et remontage de la machine HAULOTTE®.

2 Prévention des risques**Moyens de protection à utiliser pendant toute la réalisation de la gamme**

	Tenue de travail appropriée		Gants
	Chaussures de sécurité		

3 Prérequis

	- Outillage standard		- Balisage du secteur
--	----------------------	--	-----------------------

4 Procédure de test

Le système de freinage est un élément essentiel de la sécurité de la machine. Les tests suivants doivent être effectués périodiquement.

Etape 1 :

Données générales

D - Fiches machine

Procédure de test de freinageMS0004

Pupitre de commandes haut

Étape	Action
1	Sur une surface plane ou légèrement inclinée (inclinaison toujours inférieure au dévers autorisé : voir la plaque signalétique du fabricant).
2	Tracer sur le sol une ligne qui sera utilisée comme le marquage référence pour l'arrêt.
3	Rouler en avançant jusqu'à atteindre la vitesse maximale :  Se référer à la section B - Caractéristiques techniques.
4	Relâcher le manipulateur dès que les essieux de roue sont au niveau du marquage référence tracé.
5	Machine arrêtée, mesurer la distance entre les essieux de roue et le marquage référence tracé sur le sol : <ul style="list-style-type: none"> - La distance de freinage doit être inférieure à 1,1m (3 ft 7 in). - Sinon, contacter HAULOTTE Services® afin de réparer le système.



Les étapes 2 et 3 sont des procédures d'inspection périodique à réaliser en cas d'intervention sur les freins (maintenance, réparation) et sur une mise à jour de software

Étape 2 :

Pupitre de commandes haut

Étape	Action
1	Tirer les boutons poussoirs d'arrêt d'urgence sur le pupitre de commandes bas et sur le pupitre de commandes haut.
2	Positionner le sélecteur à clé du pupitre de commandes bas en position pupitre de commandes haut.
3	Sélectionner la petite vitesse de translation , puis actionner le manipulateur de translation et la gâchette du manipulateur .
4	 Dans cette configuration, l'arrêt de la machine est brutal. Tenez vous fermement aux gardes-corps. Enfoncer le bouton poussoir d'arrêt d'urgence sur le pupitre de commandes haut. S'assurer que la machine s'arrête rapidement et sans dérive.

Étape 3 :



Vérifier l'absence de risques dans la zone d'essais :

- Positionner la machine sur un sol plat, ferme et dégagé (attention aux lignes électriques).
- S'assurer qu'une distance suffisante est disponible pour arrêter la machine en toute sécurité.
- Positionner les roues directrices de manière à ce qu'elles soient droites.
- Établir un balisage de sécurité autour de la zone de test.

Données générales

D - Fiches machine

Procédure de test de freinage

MS0004

Pupitre de commandes haut

Étape	Action
1	Tirer les boutons poussoirs d'arrêt d'urgence sur le pupitre de commandes bas et sur le pupitre de commandes haut.
2	Positionner le sélecteur à clé du pupitre de commandes bas en position pupitre de commandes haut.
3	Sélectionner la petite vitesse de translation , puis actionner doucement le manipulateur de translation.
4	Engager la machine en marche avant à faible vitesse sur une rampe présentant une inclinaison inférieure à la pente maximale admissible.
5	Relâcher le manipulateur.
6	La machine effectue un arrêt complet. Maintenir la machine immobilisée pendant une durée de 5 secondes.
7	S'assurer de la capacité des freins à maintenir l'immobilisation. La machine doit rester immobile.

General data

D - Machine sheets

Braking test procedure

MS0004



1 Warning



- Only an authorised and qualified technician is permitted to work on the machines HAULOTTE®.
- The use of this form implies that its user has been trained on this type of equipment.
- It is important that the person working on the machine is familiar with all of the safety information contained in the user manual.
- Generally speaking, the user must comply with regulatory obligations in force, particularly those relating specifically to working alone, co-activity and manual load handling...
- The user must have all the permits/authorizations required to work (fire permit, etc.) and comply with the specific safety instructions at the intervention site.
- Only risks linked specifically to activities relating to the disassembly and assembly of the machine HAULOTTE® are described in this sheet.

2 Risk prevention

Means of protection to be used when implementing the range

	Appropriate workwear		Gloves
	Safety shoes		

3 You will need

	- Standard tool kit		- Place barriers around the perimeter of the work area
---	---------------------	---	--

4 Test procedure

The brake system is a significant component of the safety of the machine. The following tests must be performed periodically.

Step 1:

General data

D - Machine sheets

Braking test procedureMS0004

Platform control box

Step	Action
1	On a flat ground or slightly inclined (always lower than the authorized slope: see plate manufacturer).
2	Trace on the ground, a line being used as reference mark of stop.
3	Roll moving front until reaching maximum speed:  Refer to section B - Technical specifications.
4	Release the manipulator as soon as the wheels axles are on the level of the traced reference mark.
5	Stopped machine, measure the distance between the wheel axles and traced reference mark on the ground: - Braking distance must be less than 1,1m (3 ft 7 in). - If not, Contact HAULOTTE Services® to repair the system.



Steps 2 and 3 are periodic inspection procedures to be performed in case of operations on the brakes (maintenance, repair) and on a software update

Step 2:

Platform control box

Step	Action
1	Pull both E-Stop buttons; at ground box and at platform box.
2	Turn the ground control box selector key to platform control box position.
3	Select the low drive speed , then activate the drive joystick and the joystick trigger .
4	 In this configuration, stopping the machine is brutal. Hold onto the guardrails tightly. Press the emergency pushbutton on the platform control box. Ensure that the machine stops quickly and does not drift.

Step 3:



Check that there are no hazards in the test area:

- Position the machine on a flat and firm surface, clear of obstructions (beware of power lines).
- Ensure that there is sufficient distance to stop the machine in complete safety.
- Position the steered wheels so that they are straight.
- To set up a beaconing of safety around the test area.

General data

D - Machine sheets

Braking test procedure

MS0004

Platform control box

Step	Action
1	Pull both E-Stop buttons; at ground box and at platform box.
2	Turn the ground control box selector key to platform control box position.
3	Select low drive speed , then slowly move the drive joystick.
4	Drive the machine forward in low speed on a ramp inclined at less than the maximum authorized slope.
5	Release joystick.
6	The machine comes to a complete stop. Keep the machine immobilized for 5 seconds.
7	Check the ability of the brakes to keep the machine immobilized. The machine must remain immobile.