



# Training manual

## (BT24-30RT)

### Self-Propelled Telescopic Boom Lifts





# Revision history

<b>version number</b>	<b>Creation date</b>	<b>founder</b>	<b>Review</b>
Rev1.0	Mar 2020	Chengchao Shi	Weiliang Huang



**Contents**

<b>1. Safety Regulation</b> .....	1
<b>1.1 Personal safety</b> .....	2
<b>1.2 Battery related safety regulations</b> .....	3
<b>2. Parts Introduction</b> .....	2
<b>2.1 Introduction of hydraulic and mechanical components</b> .....	3
<b>2.1.1 Introduction of chassis hydraulic and mechanical components</b> .....	4
<b>2.1.2 Introduction of rotation hydraulic and mechanical components</b> .....	7
<b>2.2 Introduction of electric components</b> .....	8
<b>2.2.1 Introduction of classic electric components</b> .....	8
<b>2.2.2 Introduction of turntable electrical components</b> .....	13
<b>2.2.3 Introduction of platform electrical components</b> .....	15
<b>3. Pre-operative inspections</b> .....	17
<b>3.1 pre-operative inspection</b> .....	18
<b>3.2 Inspection of the workplace</b> .....	20
<b>3.3 functional test</b> .....	21
<b>3.3.1 Controls on the ground</b> .....	24
<b>3.3.2 Controls on the platform</b> .....	24
<b>3.4 operating instructions</b> .....	27
<b>3.5 Emergency Stowing</b> .....	28
<b>4. Operation</b> .....	31
4.1 Ground control panel.....	32
4.2 Control panel on platform .....	36
.....	36
4.3 Transportation notice.....	45
4.4 Blocking the chassis .....	45
4.5 Blocking the platform.....	46
4.6 Towing the vehicle .....	46

## Contents

4.7 Lifting.....	48
<b>5. Display interface .....</b>	<b>49</b>
<b>5.1 Boot interface .....</b>	<b>50</b>
5.2 Home interface .....	50
<b>5.2.1 Home interface button definition .....</b>	<b>50</b>
<b>5.2.2 Home interface icon definition .....</b>	<b>51</b>
5.3 Engine status interface.....	53
5.4 Vehicle condition interface .....	53
<b>5.5 Vehicle quick setting interface (No password required).....</b>	<b>53</b>
5.6 Prompt cache button.....	54
<b>5.7 Alarm/warning interface (Automatic switching).....</b>	<b>54</b>
5.8 Main menu.....	55
<b>5.8.1 Diagnose interface .....</b>	<b>55</b>
<b>5.8.2 Tools interface.....</b>	<b>56</b>
<b>5.8.2.1 backlight setting interface.....</b>	<b>56</b>
<b>5.8.2.2 Clock setting menu .....</b>	<b>57</b>
<b>5.8.2.3 Language setting interface .....</b>	<b>57</b>
<b>5.8.3 Password interface .....</b>	<b>58</b>
<b>6. Diagnose interface .....</b>	<b>59</b>
<b>6.1 Basic data .....</b>	<b>60</b>
<b>6.2 I/O status .....</b>	<b>60</b>
<b>6.2.1 Chassis Controller I/O diagnose.....</b>	<b>60</b>
<b>6.2.2 Cage controller I/O diagnose.....</b>	<b>61</b>
<b>6.3 Sensor status .....</b>	<b>63</b>
<b>6.3.1 Chassis angle .....</b>	<b>63</b>
<b>6.3.2 Cage angle (BT26S/30 valid).....</b>	<b>63</b>
<b>6.3.3 Jib angle.....</b>	<b>64</b>
<b>6.3.4 Main boom angle .....</b>	<b>65</b>
<b>6.3.5 Main boom length.....</b>	<b>65</b>

---

## Contents

6.3.6 Load cell diagnose .....	65
6.3.7 Hydraulic oil temperature .....	66
6.3.8 Fuel level gauge.....	66
6.4 Engine alarm.....	66
6.5 Movement diagnose .....	67
6.5.1 Main Boom Amplitude.....	67
6.5.2 Main Boom Telescope .....	67
6.5.3 Jib Amplitude .....	68
6.5.4 Jib Telescope .....	68
6.5.5 Cage Rotation .....	68
6.5.6 Turret Rotation.....	68
6.5.7 Cage Levelling.....	69
6.5.8 Jib Leveling (Only for telescopic models) .....	69
6.5.9 Travel Movement .....	69
6.5.10 Wheel Steering.....	69
7. Parameter adjustment .....	70
7.1 Enter password.....	71
7.2 Function setting .....	72
7.2.1 Function parameter.....	72
7.2.2 Limit parameter .....	73
7.2.3 Movement parameter.....	74
7.2.3.1 Main boom amplitude.....	74
7.2.3.2 Main boom telescope.....	75
7.2.3.3 Jib amplitude .....	75
7.2.3.4 Jib telescope (Only for models with telescoping jib).....	75
7.2.3.5 Cage rotation .....	75
7.2.3.6 Turret rotation.....	75
7.2.3.7 Cage levelling.....	75
7.2.3.8 Jib levelling (Only for models with telescoping jib).....	75
7.2.3.9 Travel movement .....	76

## Contents

7.2.3.10 Wheel steering.....	76
7.3 Sensor calibration.....	76
7.4 Data logger .....	76
7.5 Bypass parameter .....	76
8. Sensor calibration.....	78
8.1 Enter password.....	79
8.2 Sensor calibration interface.....	79
8.2.1 Chassis angle sensor calibration.....	79
8.2.2 Platform angle sensor calibration .....	79
8.2.3 Jib level sensor calibration .....	80
8.2.4 Main boom angle sensor calibration.....	80
8.2.5 Main boom length sensor calibration .....	80
8.2.6 Load sensor calibration.....	81
8.2.6.1 No-load calibration of load sensor.....	81
8.2.6.2 Load calibration of load sensor .....	81
9. Electrical Schematic .....	82
9.1 Engine electrical schematic.....	83
9.2 Ground control electrical schematic .....	84
9.3 Platform control electrical schematic .....	85
10. Hydraulic Schematic .....	86
10.1 BT24RT&BT26RT&BT28RT Hydraulic Schematic .....	87
10.2 BT26SRT&BT30RT Hydraulic Schematic .....	88
11. Alarm code and solution guide.....	89
11.1 Alarm codes and solutions list.....	90
11.2 Prompt code list and solution .....	100
11.3 Solutions to common problems .....	102
11.3.1 The upper part of the platform frame hits an obstacle and causes the machine to appear overload alarm .....	102
11.3.2 The bottom of the platform frame hits the ground or other obstacles causing the machine to have a load cell 2 open circuit error .....	103

**Contents**

11.3.3 Redundancy failure of length and angle sensor in ground display ..... 103

11.3.4 The vehicle cannot start the engine..... 103

12. Maintenance..... 104

    12.1 Observe and Obey:..... 105

    12.2 Preliminary checks:..... 105

    12.3 MAINTENANCE SCHEDULE ..... 105

        12.3.1 Checklist A Procedures ..... 106

        12.3.2 Checklist B Procedures ..... 108

        12.3.3 Checklist C Procedures ..... 111

        12.3.4 Checklist D Procedures ..... 113

        12.3.5 Checklist E Procedures ..... 117

        12.3.6 Checklist F Procedures ..... 120

        12.3.7 Checklist G Procedures..... 121



# 1. Safety Regulation

# Safety Regulation

## 1.1 Personal safety

### Personal protection against falls

Before using this machine, personal protective equipment (DPI) to prevent fall from height is required. Personnel inside the platform must wear safety belts or safety slings in accordance with current national regulations. Secure the safety anchor rope to the connection on the platform. Personnel must comply with current national regulations and the rules of employers and the workplace regarding the use of personal protective equipment against fall from height. All personal protective equipment must comply with current national regulations and must be inspected and used in accordance with the personal protective equipment manufacturer's instructions.

### Work area safety

The machine is not electrically isolated and does not provide protection against contact or access to electrical wiring.



Observe the local and national regulatory standards in force concerning the distance required from electricity lines. At least the safety distance indicated in the Table below must be respected.

Line voltage	Minimum distance
from 0 to 50 KV	3.05 m
from 50 to 200KV	4.60 m
from 200 to 350KV	6.10 m
from 350 to 500KV	7.62 m
from 500 to 750KV	10.67 m
from 750 to 1,000KV	13.72 m



Move away from the machine in case of contact with live electricity lines. Workers on the ground or on the platform must not touch or operate the machine until the electric power supply has been disconnected.

Do not use the machine in case of thunder storms or lightning. Do not use the machine as earth for carrying out welding operations.

## Warning

### Danger of tilting over

The workers, equipment and materials must not exceed the maximum capacity of the platform or of the platform extension element.

Maximum platform capacity		
Model	Maximum platform capacity	Maximum number of occupants
BT30RT	450/300kg	3
BT28RT	450kg	3
BT26RT	450kg	3
BT24RT	450kg	3

If accessories are used, read, understand and follow the indications on the stickers, instructions and Manuals supplied with the accessories.



Do not raise or extend the boom unless the machine is placed on a stable level surface.



Never exceed the maximum permitted inclination of the truck; the maximum permitted inclination of the truck is indicated in the technical specifications and on the ID plate on-board the machine.

Do not use the inclination alarm as a level indicator. The inclination alarm sounds in the platform only when the machine is on a steep slope.

If the inclination alarm sounds when the boom is lowered, do not extend, rotate or raise the boom with respect to the horizontal position. Move the machine to a stable level surface before lifting the platform.

## Safety Regulation

If the inclination alarm sounds while the platform is lifted, use it with utmost care. The indicator lights up if the machine is not level and the side-shift function in one or both directions is not operative. Stabilise the position of the boom with respect to the slope as shown below. Follow the procedure to lower the boom before moving the machine to a stable, level surface. Do not rotate the boom while lowering it.

### If the inclination alarm sounds when the platform is oriented towards the ascending part of the slope:

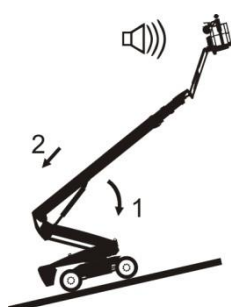

- 1 Lower the main boom.
- 2 Retract the main boom.

### If the inclination alarm sounds when the platform is oriented towards the descending part of the slope:

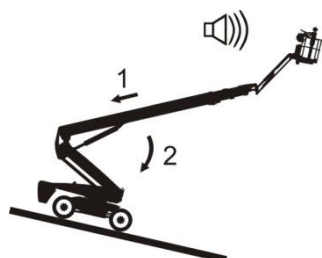

- 1 Retract the main boom.
- 2 Lower the main boom.

### Do not raise the boom if the wind speed can exceed 12.5 m/s. If the wind speed exceeds 12.5 m/s when the boom is raised, lower the boom and suspend use of the machine.

Do not increase the surface or the load of the platform. The increased surface exposed to the wind reduces the stability of the machine.



Use utmost caution and low speed when the machine is moved with the platform retracted on surfaces that are irregular, unstable, with detritus or slippery, or near ditches and cliffs. Do not move the machine or close to irregular, unstable surfaces or those with other hazardous conditions when the boom is raised or extended.



Make sure the ground is able to support the weight of the machine indicated in the technical specifications in the Manual. Do not use the machine on muddy, icy, slippery, uneven ground or where there are holes in the ground.

Do not use the machine to lift hanging loads; do not use it as a crane.

Do not use the machine to lift loads in the platform, and it must not be used as a lift.

Do not use the machine to transfer persons from one floor to another one, and do not use it as a lift.

Do not push the machine or other objects using the machine boom.

Do not allow the boom to come in contact with adjacent structures.

Do not fix the boom or platform to adjacent structures.

Do not position loads outside the platform perimeter.



Do not pull or push on any object which is outside the platform. Maximum permitted manual stress – CE 400N.

Do not modify or deactivate the components which affect the safety and stability of the machine.

Do not replace the components crucial for the stability of the machine with components which have different weight or technical specifications.

Do not replace the original tyres with tyres having different technical specifications or different serial number.

Do not replace the tyres with original foam rubber filling with tyres having inner tube. The weight of the wheels is important for the stability of the machine. The tyres with wide profile must be installed by the machine manufacturer. Do not

## Safety Regulation

replace the original standard tyres with models having wide profile. Do not modify or alter an aerial work platform without written authorisation from the manufacturer. Attaching fittings for supporting tools and other materials on the platform, on the foot board or on the platform railing increases the weight and exposed surface of the platform or of the load.



Do not position or fix weights or loads projecting from any part of the machine.



Do not position ladders or scaffolding inside the platform or against any part of the machine.

Do not transport equipment and materials if the load is not distributed appropriately and if it cannot be controlled by personnel on the platform in safety conditions. Do not use the machine on a mobile surface or on a moving vehicle. Make sure all the tyres are in good condition, that the pressure of the tyres with inner tube is appropriate and that the crown nuts are tightened correctly. Do not use the controls in the platform to free the platform if it is blocked or obstructed in any way by an adjacent structure which prevents its normal movement. All the workers must leave the platform before trying to free it using the controls on the ground.

### Danger due to movement on slopes ⚠

Do not move the machine on a slope that exceeds the maximum limits established for ascent, descent and lateral movement of the machine. The slope limit only refers to machines in the retracted position.

Maximum slope limit	
Platform in descent	24.2° (45%)
Platform in ascent	24.2° (45%)
Lateral slope	5° (8.7%)

**Note: The slope limit depends on the conditions of the ground and presupposes an adequate traction. Consult the section regarding the machine transfer on a slope in the operating instructions chapter.**

### Danger of falling ⚠



The workers in the platform must wear a safety belt or harness in compliance with the national regulations in force. Fix the safety cord to the fittings present on the platform and indicated by the graph alongside.



Do not sit, stand or climb on the railings of the platform. Always maintain a stable position on the platform foot board.



Do not climb down from the platform if it is raised.

Keep the platform foot board free of detritus. Lower the safety bar or close the entrance gate before using the platform. Do not enter or leave the platform if the machine is not in a retracted position and the platform is not at ground level.

### Danger of collision ⚠

Take care in situations of pure visibility and blind spots while driving or during the man oeuvre. Take into consideration the position of the boom or the drift during the rotation of the slewing ring gear.

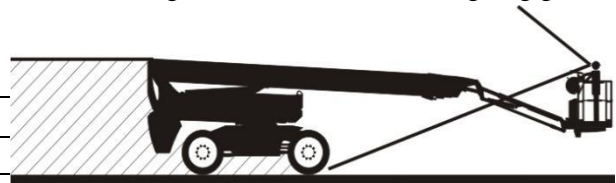

## Safety Regulation



Check the work area to make sure there are no obstacles at a height or other potential hazards.



Take extreme care while gripping the platform railing to prevent danger of crushing.

color codes on the platform controls and on the chassis and the organs for side-shift and steering operations.



Do not lower the boom if the area underneath is not clear of persons or obstructions.



Reduce the transfer speed according to the conditions of the ground, the traffic, the slopes, presence of workers or other factors which can cause collisions.

place by the employer, the workplace and the national safety standards in force concerning use of the personal protective equipment for protection from falling from a height.

Always observe the use the direction arrows with

## Safety Regulation

### Danger of personal injuries

Always use the machine in a well-ventilated area to prevent the risk of poisoning by carbon monoxide.

Do not use the machine if there is an oil or air leak. Hydraulic or air leaks can cause injury to the skin and burns.

Contact with the components present in any of the compartments can cause serious personal injury. Access to the machine compartments must only be allowed for workers qualified for maintenance. Access these compartments only during pre-operative checks. All the compartments must remain closed and locked during the working of the machine.

### Danger of explosion and fire

Do not start up the engine if there is an odour or trace of LPG, petrol, diesel or other explosive substances.

Do not refuel the machine if the engine is switched On.

Refuel the machine solely in a well-ventilated area far away from sparks, flames and lighted cigarettes.

Do not use the machine in hazardous ambient or in the presence of gas or flammable or explosive materials or in areas with explosive atmosphere.

Do not spray ether in engines fitted with pre-heating spark plugs.

### Dangers due to faulty machine

Do not use damaged or faulty machines.

Proceed with detailed pre-operative checking of the machine and test all the functions before each work shift. Mark and put damaged or faulty machines immediately out of service.

Make sure the maintenance checks have been carried out as specified in this Manual and in the DINGLI Maintenance Manual concerned. Make sure all the stickers are present and legible. Make sure the Operator Manual, Manuals on safety and responsibilities are intact, legible and placed safe inside the container concerned on the machine.

### Hazards linked to the work area

Do not use the machine in environmental temperatures below  $-20^{\circ}\text{C}$  or above  $40^{\circ}\text{C}$ . To operate at other environmental temperatures, contact the manufacturer.

Do not use the machine in the presence of an explosive atmosphere.

Do not use the machine if the environmental lighting does not ensure sufficient visibility in carrying out the jobs or movements in safety conditions.

Do not use the machine if someone is present in the range of actions of the machine and in the immediate vicinity.

---

## Safety Regulation

### 1.2 Battery related safety regulations

#### Danger of burns

The batteries contain acid. Always wear protective clothing and glasses when working with the batteries.

Do not spill the battery acid and avoid contact with it. Neutralise leakage of acid from the batteries with sodium bicarbonate and water.

#### Block after every use

1. Identify a safe parking area with a level stable surface, free of obstacles and traffic.
2. Retract and lower the platform.
3. Align the turret with the truck axis.
4. Turn the key-operated switch of the control panel on the ground to OFF (O) and remove the key to prevent the machine being used by unauthorised personnel.

## **2. Parts Introduction**

## Parts Introduction

### 2.1 Introduction of hydraulic and mechanical components

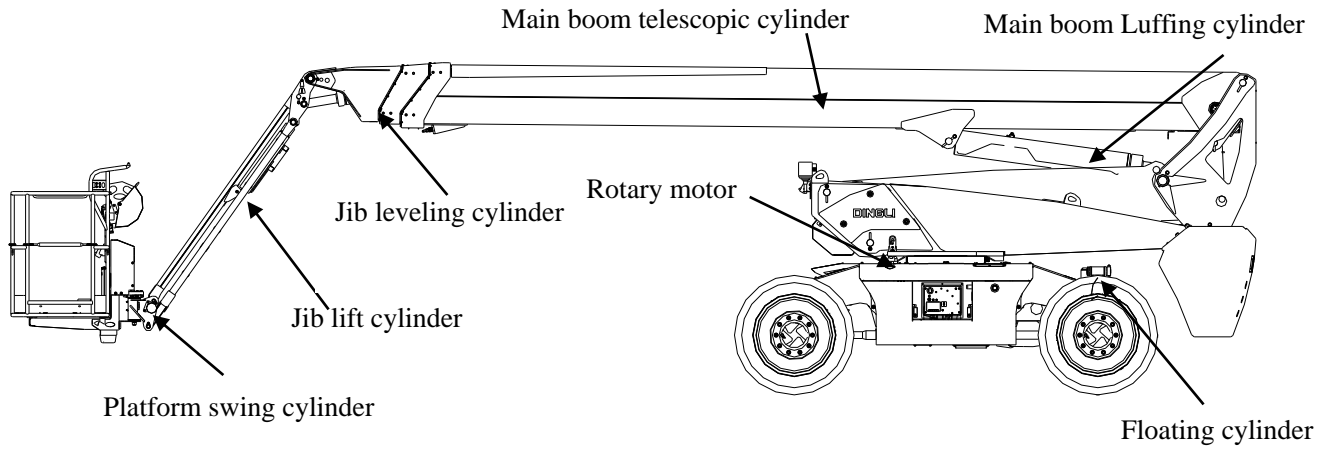



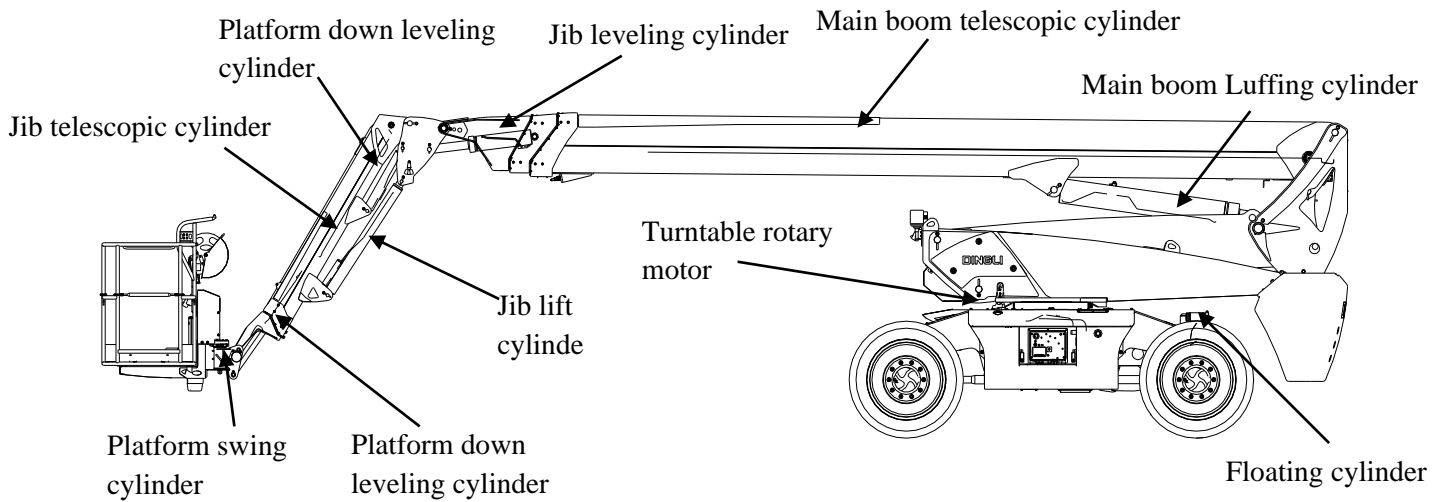

**Picture of BT Without Telescopic Jib Machine's Cylinder**





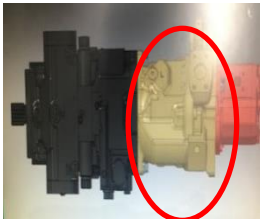
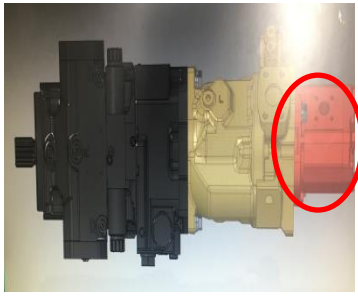

**Picture Of BT With Telescopic Jib Machine's Cylinder**

## Parts Introduction



### 2.1.1 Introduction of chassis hydraulic and mechanical components

No.	components	Description
1	<p style="text-align: center;">Engine</p> 	<p>The German Deutz 4-stage engine is used, which is located on the side of the chassis. The engine is the source of power for the vehicle.</p>
2	<p style="text-align: center;">Drive pump</p> 	<p>It uses German Rexroth to drive the oil pump, which is located between the engine and the functional pump in the chassis. The engine drives this part to provide hydraulic power for the walking function.</p>
3	<p style="text-align: center;">Function pump</p> 	<p>Adopt German Rexroth functional oil pump, which is located between the driving oil pump and the fan oil pump in the chassis. This part is driven by the engine to provide hydraulic power for the functional part of the vehicle.</p>
4	<p style="text-align: center;">Engine fan pump</p> 	<p>The Swiss Buch fan oil pump is used, which is located in the chassis and connected to the functional oil pump. The engine drives this part to provide hydraulic power for the hydraulic motor radiator of the engine.</p>
5	<p style="text-align: center;">Emergency pump</p> 	<p>Located in the chassis, this component is driven by the motor to provide auxiliary power to the functional part when the engine cannot be started.</p>

## Parts Introduction

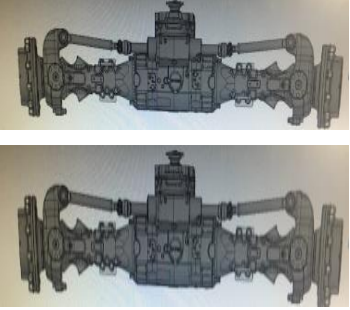

No.	components	Description
6	<p>Drive motor</p> 	<p>A German Rexroth drive motor is used, which is located in the chassis and connected to the transmission axle. The drive oil pump provides hydraulic power for this component to drive the four-wheel walking.</p>
7	<p>Engine cooling motor</p> 	<p>The hydraulic motor of the Swiss Bucher fan is located on the engine side, and this component is driven by the fan oil pump to dissipate heat for the engine cooling system.</p>
8	<p>Hydraulic cooling system</p> 	<p>Located in the chassis, it is used to dissipate the hydraulic oil returned to the hydraulic oil tank to ensure that the hydraulic oil is in the best working state. Overheated hydraulic oil will affect the working efficiency of the entire hydraulic system.</p>
9	<p>Filter</p> 	<p>Located in the chassis, it is used to filter the hydraulic oil of the entire hydraulic system. Filtering out the hydraulic system is the prerequisite for the machine to work normally and stably.</p>
10	<p>Classic function manifold</p> 	<p>Located in the chassis, it is used to control the driving functions of the vehicle chassis, including driving the axle differential lock, brakes, and four-wheel steering.</p>

## Parts Introduction

No.	components	Description
11	<p style="text-align: center;">Drive axle</p> 	<p>The American Dana transmission axle is used to drive the whole vehicle under the chassis, which is divided into two groups connected by the transmission shaft. Transmission efficiency because the pressure loss of the diverter valve is eliminated, it is more than 20% higher than the traditional wheel-side deceleration drive, the power is more powerful and the failure rate is low. The axle comes with a 100% hydraulic differential lock, and the ground clearance is small, which can adapt to the harsh working conditions that traditional wheel-side deceleration drives are not competent.</p>
12	<p style="text-align: center;">Floating cylinder and lock valve</p> 	<p>The United States HydraForce axle floating lock valve is used to ensure that the four wheels touch the ground to enhance the grip of the drive wheels when the car is in the folded state, and to lock the floating function when the car is at high altitude. When the spool is stuck and fails, the lock valve will immediately feed back to the control system through an electrical signal, prompting the system to alarm and cut off all dangerous actions to ensure the personal safety of the operator, which is more secure than the traditional technical solutions.</p>
13	<p style="text-align: center;">Central Rotation</p> 	<p>It adopts the Italian HBS central rotation, which is located in the chassis and is divided into a hydraulic connection part and an electrical connection part, which is the link between the chassis and the turntable.</p>

## Parts Introduction





### 2.1.2 Introduction of rotation hydraulic and mechanical components

No.	Components	Description
1	Platform function manifold  Without telescopic machine	Located on the upper part of the swing cylinder, it is used to control the amplitude of the arm and switch the swing function of the platform frame.
	 With telescopic machine	Located on the upper part of the swing cylinder, it is used to control the swing of the platform frame, the amplitude change of the arm, the telescoping of the arm and the leveling of the platform frame.
2	PVG function manifold 	The Danfoss PVG32 valve group is used in the front of the turntable to control the boom movement of the vehicle, including the main arm telescopic, main arm luffing, turntable rotation, platform leveling, arm function, CAN bus precision control Good dynamism, simple electric control circuit, the system comes with fault diagnosis function for easy troubleshooting, highly integrated electromagnetic directional valve, manual directional valve, proportional valve and overflow valve, etc.



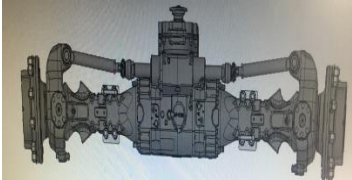

## Parts Introduction

### 2.2 Introduction of electric components





#### 2.2.1 Introduction of classic electric components

No.	Components	Description
1	<p>Battery</p> 	<p>Located in the chassis, it provides power to the vehicle's electronic control system when the engine is not working, and also stores the power generated by the generator.</p>
2	<p>Emergency pump motor</p> 	<p>Located in the chassis, the emergency pump motor drives the emergency pump to temporarily power the hydraulic system of the functional part when the engine cannot be started.</p>
3	<p>Cooling system</p> 	<p>Located in the chassis, it dissipates the hydraulic oil returning to the tank, prevents the hydraulic oil temperature from being too high, and ensures that the hydraulic oil is in the best working state.</p>
4	<p>Hydraulic oil temperature sensor</p> 	<p>Located on the hydraulic oil radiator of the chassis, it can monitor the current temperature of the oil flowing through the radiator and return to the hydraulic oil tank in real time. The oil is in the best working condition.</p>
5	<p>axle neutral sensor</p> 	<p>Located on the axle, it is used to detect whether the steering wheel is in the neutral position. When the tires on both sides are in the neutral position, the indicator light on the platform display will work.</p> <p>Both front and rear axles are equipped with this sensor.</p>





## Parts Introduction

No.	Components	Description
6	Floating valve displacement sensor 	Located on the floating valve block, it is used to detect the working state of the floating lock valve in real time. When the spool is stuck, the machine will prompt a fault. Both the left and right floating valve blocks have this sensor.
7	Emergency pump contactor 	Located on the engine side, it is used to drive the emergency pump to temporarily power the hydraulic system of the functional part when the engine cannot be started.
8	Power switch 	Located on the engine side, it is used to cut off the connection between the battery and the vehicle electrical system. When parking for a long time, it is recommended to cut off the switch to reduce the self-discharge of the machine.
9	Auxiliary wiring pile 	Located on the engine side, the black on the left is the negative pole of the 12V power supply and the red on the right is the positive pole of the 12V power supply. When the original car battery loses power, it is used to connect an external auxiliary battery to start the engine.
10	Engine preheating contactor 	Located on the engine side, when the ambient temperature is low, the engine ECU will control the component to preheat the engine cylinder to ensure the smooth start of the engine in a cold environment.





## Parts Introduction

No.	Components	Description
11	<p>High current fuse box</p> 	<p>Located on the engine side, it is used to protect the large current working device of the vehicle to prevent it from being damaged after overload operation. Including engine generator fuse, emergency pump motor fuse, electrical control circuit fuse, engine preheat fuse.</p>
12	<p>Electrical diesel pump</p> 	<p>Located under the air filter, it supplies oil to the engine when the system is powered on.</p>
13	<p>Engine oil-water filter</p> 	<p>Located at the front of the engine radiator, when the internal water level of the separator reaches the upper limit, the trigger signal will be transmitted to the electronic control system, and the engine oil-water separation fault code will appear on the lower display to remind the operator to drain the engine fuel system.</p>
14	<p>Engine diesel fine filter</p> 	<p>Located on the front of the engine radiator, the upper sensor is used to sense the output pressure of the electronic diesel pump and feed back the collected pressure signal to the engine ECU for its processing.</p>

## Parts Introduction





No.	Components	Description
15	Air filter check switch 	Located on the engine air filter, it is used to monitor the working status of the engine air filter in real time. When the air filter is clogged, the trigger signal will be transmitted to the electronic control system, and the air filter fault will appear on the lower display.
16	Engine generator 	Located on the engine and connected to the crankshaft with a belt. When the engine is working, it supplies power to the electronic control system and charges the battery.
17	Engine starter motor 	Located on the engine, used to drive the engine flywheel to start the engine.
18	Engine compartment door frame switch 	Located on the engine side, it is used to detect the state of the engine door. When the door is open, the display will show a prompt and beep, and the engine start function will be limited. If the door is opened when the engine is in operation, the engine will immediately shut down. This function can be temporarily turned off on the lower display screen. It is used to start the engine with an external auxiliary battery when the original battery of the vehicle is fed.
19	Diesel location sensor 	Located on the diesel tank, it is used to detect the fuel level in the diesel tank. The real-time fuel level will be displayed on the main page of the display.

## Parts Introduction



No.	Components	Description
20	<p>Control system fuse and relay box</p> <p>Old relay box      New relay box</p> 	<p>Located in the door of the lower control panel, it is used to protect the small current working device of the vehicle to prevent it from being damaged after overload operation. Including engine fuel pump relay and its fuse, hydraulic oil radiator fan relay and its fuse, main power relay and its fuse, etc.</p>
21	<p>ECU</p> 	<p>Located in the door of the lower control panel, the sensor transmits the collected signal to the controller. The controller coordinates the logic of the vehicle's electrical control system and is the brain of the vehicle.</p>
22	<p>Level sensor</p> 	<p>Located in the cabin door of the lower control panel, it is used to monitor the chassis status of the vehicle in real time, and transmit the actual angle value to the main controller in the form of a message through the CAN bus for its processing. When the vehicle is walking at high altitude and the level sensor exceeds the maximum allowable tilt angle of 5 °, the vehicle will display a tilt alarm prompt. The real-time angle value of the level sensor can be viewed on the display vehicle condition interface.</p>
23	<p>Engine ECU</p> 	<p>Located in the cabin door of the lower control panel, it communicates with the main controller through the CAN bus. It is used to collect signals from various sensors on the engine and control the working status of each actuator. It has absolute control over the engine.</p>
24	<p>Display</p> 	<p>Located on the lower control operation panel, it is used to display the fault code of the electronic control system, the status of each sensor of the vehicle, the adjustment of the machine parameters, and the fault diagnosis of the vehicle.</p>

## Parts Introduction

### 2.2.2 Introduction of turntable electrical components





No.	Component	Description
1	Turntable middle switch 	Located in the middle of the turntable, there are a total of three proximity switches, which are the left front proximity switch for the turntable alignment, the right side proximity switch for the turntable alignment front, and the middle position proximity switch for the turntable alignment front. Processor, the main controller restricts the relevant actions according to the actual operating conditions.
2	Main boom down limit switch 	Located in the middle of the turntable, on the left and right sides of the main arm, it is used to detect whether the main arm is in the folded state. The main controller limits the relevant actions according to the actual working conditions.
3	Platform AC power plug 	Located at the front of the turntable, when the plug is connected to 220V AC power, the socket on the platform is supplied with 220V power.
4	PVG32 manifold 	Located at the rear of the turntable, it communicates with the controller via the CAN bus and is used to control the boom extension, boom swing, turntable rotation, jib leveling / platform frame leveling, jib assembly function, hydraulic generator (if equipped) .
5	Length / angle sensor 	Located behind the main arm, it communicates with the controller through the CAN bus to monitor the angle and length of the main arm of the vehicle in real time, and transmits the actual angle and length values to the main controller in the form of messages for processing by the CAN bus. The main controller limits the relevant actions according to the actual operating conditions. The real-time angle value and length value of the length angle sensor can be viewed on the display vehicle condition interface.

## Parts Introduction







No.	Component	Description
6	<p>Broken link detection switch</p> 	<p>Located behind the main arm, it is used to detect the state of the telescopic arm chain. When the chain breaks, the detection switch will be triggered, and a maintenance prompt will appear after the main controller receives it.</p>
7	<p>Main boom safety valve pressure sensor</p> 	<p>Located under the boom, it is used to detect the pressure of the main arm luffing safety valve block. When the vehicle is in the lift state for a long time, the leakage of the balance valve is allowed but it will trigger the controller alarm and appear on the lower control display Prompt for the failure of the balance valve, at this time, only need to operate the main arm to change the prompt can be eliminated.</p>

## Parts Introduction

### 2.2.3 Introduction of platform electrical components

No.	Component	Description
1	Jib angle sensor (With telescopic jib machine) 	Located on the inside of the arm, it is used to detect the angle of the arm assembly in real time, and transmit the actual angle value to the main controller in the form of a message through the CAN bus for its processing. Automatic leveling. The real-time angle value can be viewed on the display vehicle condition interface.
2	Full arm retractable switch ( With telescopic jib machine) 	Located in the forearm, it is used to detect whether the forearm is in the fully retracted state, and the controller limits the relevant actions according to the actual working conditions.
3	Platform angle sensor 	Located on the platform swing cylinder, it is used to detect the angle of the platform frame in real time, and transmit the actual angle value to the main controller in the form of a message through the CAN bus for its processing. When the platform angle value exceeds the alarm setting value by 10 °, the vehicle will The fault prompt and related actions will appear, and the real-time angle value can be viewed on the display vehicle condition interface.
4	Platform load sensor 	Located on the platform swing cylinder, it is used to detect the load of the platform frame in real time. When the platform load exceeds the set value, the vehicle will show a load prompt and limit related actions. The real-time platform load value can be viewed on the display vehicle condition interface.
5	Platform controller 	Located in the upper control platform, the platform's input and output controller is used to collect and process the signals of the upper control handle operation switch, and transfer the platform information to the main controller in the form of a message through the CAN bus for its processing, and also used for drive control Platform's icon indicator.

## Parts Introduction

6	<p>AC power socket</p> 	<p>Located on the platform frame, when the AC power plug under control is connected to 220V AC power, the power outlet has power output.</p>
7	<p>Pedal</p> 	<p>Located in the platform frame, when the upper controller is selected to operate the machine, the foot safety start switch must be depressed before executing any operation command, and select the action to perform the operation within 20 seconds. If no action is selected within 20 seconds; or the last action if the interval between actions exceeds 20 seconds, the system will automatically return to the initial state. Can not operate the machine. If you want to continue the action, you must release and press the foot safety start switch again to operate. When starting the engine, the foot switch must be released.</p>
8	<p>Load cell amplifier</p> 	<p>Located in the upper control platform, the weight voltage millivolt signal collected by the weighing sensor is amplified for processing by the platform controller.</p>
9	<p>Anti-crush device</p> 	<p>Located on the platform frame, when the platform is operated, the anti-squeeze switch is triggered, and the vehicle immediately stops the current action. The yellow LED on the side lights up and is accompanied by a beep. Used to protect the safety of the operator, this function can be turned off on the lower display.</p>
10	<p>Platform LED display</p> 	<p>Located on the upper control platform, it is used to indicate the current state of the vehicle, such as driving speed, four-wheel steering mode, differential lock, front and rear axle neutral, etc.</p>
11	<p>LED work light</p> 	<p>Located on the upper control platform, there are LED control switches on the platform control panel for lighting of the upper control platform.</p>

### **3. Pre-operative inspections**

## Pre-operative inspections

### 3.1 pre-operative inspection



#### Do Not Operate Unless:

Before using the machine, it is necessary to understand and apply the fundamental principles regarding the working of the machine in the safety conditions contained in this Operator's Manual.

- 1 Avoid hazard situations.
- 2 Always carry out the pre-operative inspection.

#### Read and understand the pre-operative inspection before proceeding with the next section.

- 3 Check the work area.
- 4 Always carry out functional test before using the machine.
- 5 Use the machine only for the purposes for which it is designed: operating instructions.

### Fundamental elements of pre-operative inspection

The operator is responsible for carrying out the pre-operative inspection and routine maintenance.

The pre-operative inspection is a visual inspection carried out by the operator before every work shift. The inspection must be carried out on the machine to check for faults before the operator proceeds with testing the functions.

The pre-operative inspection is also meant to establish if routine maintenance procedures are necessary. The operator must only carry out the routine maintenance specified in this Manual.

If damage or unauthorised modification is found on the machine differing from the original conditions, mark and put the machine out of service.

The repairs must be done only by qualified technical personnel, according to the manufacturer's technical specifications. After completing the repairs, the operator must repeat the pre-operative inspection before testing the functions.

The scheduled maintenance must be carried out by qualified technical personnel, according to the manufacturer's technical specifications and the requirements listed in the Operation and Maintenance Manual of this machine.

## pre-operative inspection

- Make sure the Operator Manual, Manuals on safety and responsibilities are intact, legible and placed safe inside the container concerned on the platform.
- Make sure all the stickers are present and legible. Consult the placards and decals chapter.
- Check for oil leaks from the hydraulic system and check the correct oil level. Add oil if necessary. Consult the Maintenance chapter.
- Check for oil leaks from the engine and check the correct oil level. Add oil if necessary. Consult the Maintenance chapter.
- Check for coolant leakage from the engine and check the correct coolant level. Add coolant if necessary. Consult the Maintenance chapter.
- Check if the fuel level is correct. Some fuel may be needed to be added in if necessary. Especially, the fuel added in should be satisfied with EN590. If not, it may damage the engine.

Check the following components or the following areas for damage, missing components or incorrect assembly and unauthorised modifications:

- Electrical components, cables and wiring.
- Hydraulic piping, connections, cylinders and manifolds.
- Fuel and hydraulic tanks.
- Motors for movement of the slewing ring gear and transmission hubs.
- Braking sliding blocks.

## Pre-operative inspections

- Tires and wheels.
- Engine and its components.
- Limit switches and warning sound.
- Flashing lights and alarms (if present)
- Nuts, bolts and other safety retainer devices.
- Safety bar or platform entrance gate.
- Cord fixing point.

Check the entire machine if necessary for the presence of:

- Cracks in the welds or in the structural components.
- Dents or damage to the machine.
- Rust, oxidation or excessive corrosion.
- Make sure that all the structural components and other critical components are present and that all the relative retainers and pins are fitted and tightened properly.

After completing the inspection, make sure all the covers of the compartments are fitted in the correct position and are blocked.

Never use a faulty machine. If faults are found, the machine must be marked and put out of service. The repairs must be done only by qualified technical personnel, according to the manufacturer's technical specifications.

After completing the repairs, the operator must repeat the pre-operative inspection and test the functions before using the machine.

## Pre-operative inspections

### 3.2 Inspection of the workplace



#### Do Not Operate Unless:

☑ Before using the machine, it is necessary to understand and apply the fundamental principles regarding the working of the machine in the safety conditions contained in this Operator's Manual.

- 1 Avoid hazard situations.
- 2 Always carry out the pre-operative inspection.
- 3 **Check the work area.**  
Read and understand the work area before proceeding with the next section.
- 4 Always carry out functional test before using the machine.
- 5 Use the machine only for the purposes for which it is designed: operating instructions.

#### Fundamental elements of control of the work area

The control of the work area makes it possible for the operator to decide whether the work area is compatible with the working of the machine in safety conditions. The checking must be done by

the operator before transporting the machine to the work place. It is the operator's responsibility to remember the hazards concerning the work area and, consequently, be ready to avoid these during the movement, preparation and the working of the machine.

#### Inspection of the workplace

Identify and avoid the following hazard situations:

- cliffs or ditches
- dips, obstructions along the floor or detritus
- sloping surfaces
- support surfaces not suitable to withstand the load stresses cause by the machine
- obstacles present above the machine and high voltage electricity lines
- wind exceeding 12.5 m/s and unfavourable atmospheric conditions (rain, snow, etc.)
- ambient temperature less than -20°C or more than 40°C
- presence of explosive atmosphere
- poor or insufficient lighting
- insufficient ventilation
- hazardous environments
- presence of unauthorised workers
- other potential hazard conditions

---

## Pre-operative inspections

### 3.3 functional test



#### Do Not Operate Unless:

- ☑ Before using the machine, it is necessary to understand and apply the fundamental principles regarding the working of the machine in the safety conditions contained in this Operator's Manual.
- 1 Avoid hazard situations.
  - 2 Always carry out the pre-operative inspection.
  - 3 Check the work area.
  - 4 Always carry out functional test before using the machine.
  - 5 Use the machine only for the purposes for which it is designed: operating instructions.
  - 6 Know and understand functional testing before continuing to the next step.

#### Fundamental elements of functional test

Functional test makes it possible for the operator to make sure the machine is in safety conditions, before using the machine to work.

All the function operation must be done before starting work by the functional test operating procedures.

Never use a faulty machine. If faults are found, the machine must be marked and put out of service. The repairs must be done only by qualified technical personnel, according to the manufacturer's technical specifications.

After completing the repairs, the operator must repeat the pre-operative inspection and test the functions before using the machine.

# Pre-operative inspections

## BT26SRT/BT30RT legend

Left view

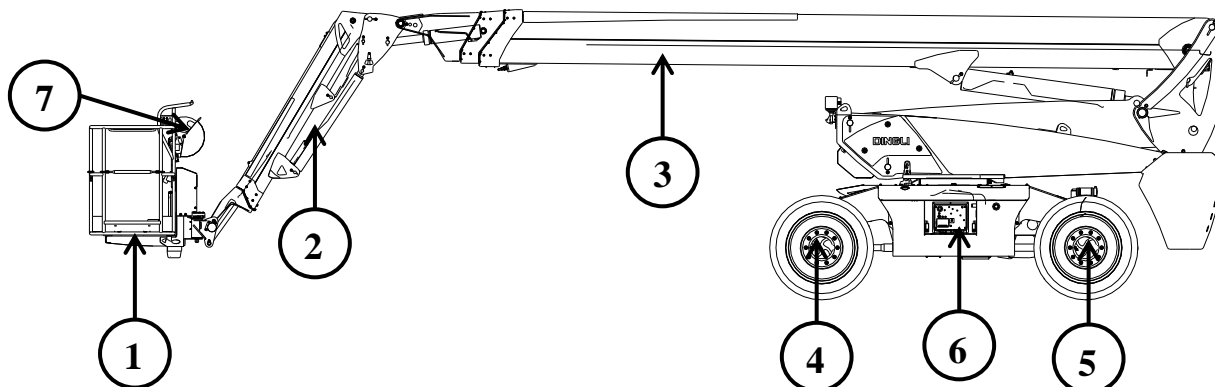

Top view

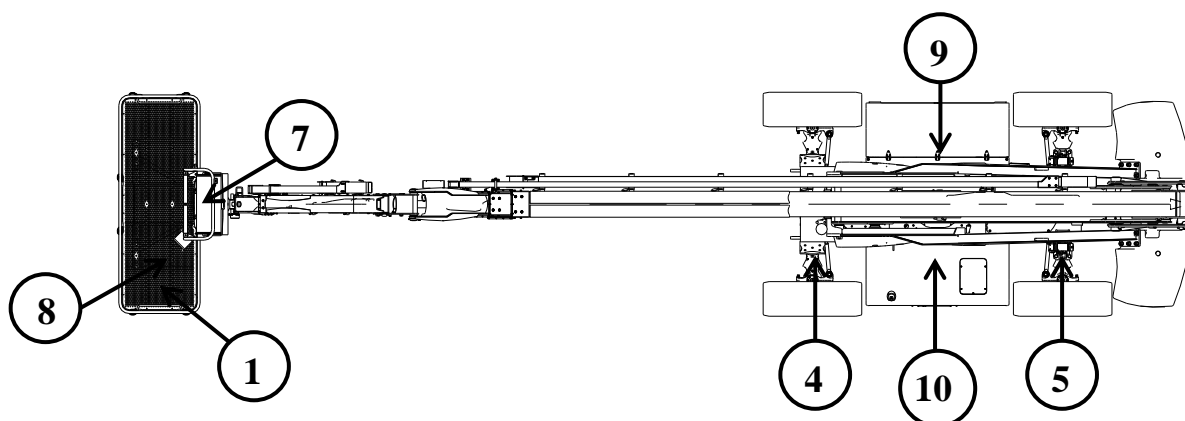

- |                        |                           |
|------------------------|---------------------------|
| 1- work platform       | 6- ground control panel   |
| 2- telescopic jib      | 7- platform control panel |
| 3-main telescopic boom | 8- pedal switch           |
| 4- rear axle           | 9- engine box             |
| 5- front axle          | 10- oil tank              |

## Pre-operative inspections

### BT24RT/BT26RT/BT28RT legend

Left view

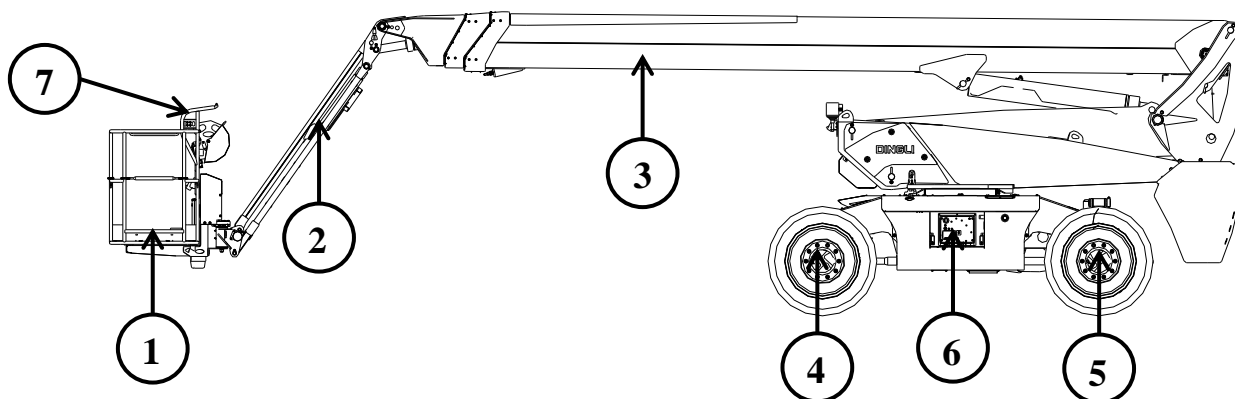

Top view

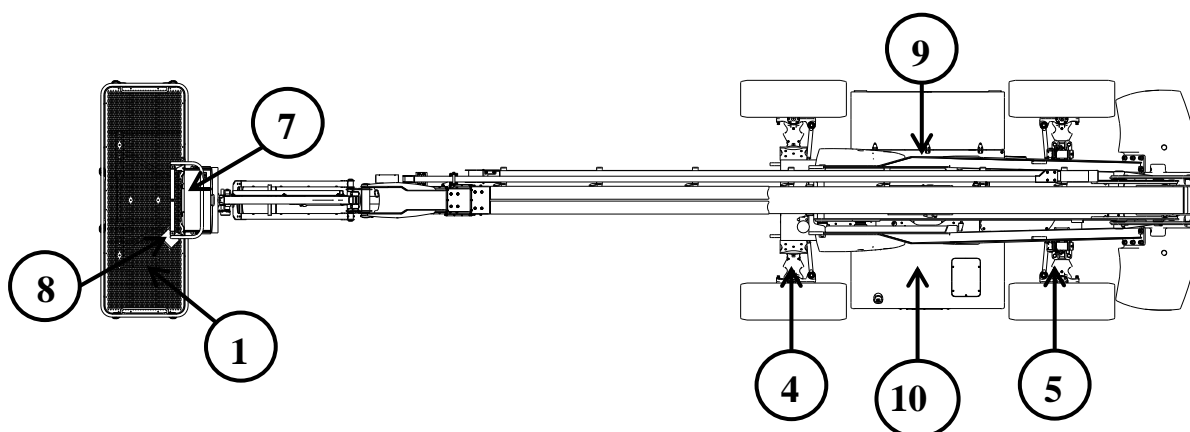

1- work platform

2-parallelogram jib

3-main telescopic boom

4- rear axle

5- front axle

6-ground control panel

7- platform control panel

8- pedal switch

9- engine box

10- oil tank

## Pre-operative inspections

### 3.3.1 Controls on the ground

- Select a stable, level work area free of obstacles.
- Position the key-operated switch of the truck panel on the controls on the ground; the LCD must light up without showing any error message.

**Note: in cold climates, the LCD display requires a short warm up time before lighting up.**

- Turn the ignition key on the symbol representing the truck then start up the engine by pressing the green button.

### Emergency stop test

- Press the red emergency stop button by turning it to the OFF position: the engine must switch off and no function can be operative.
- Turn the red stop emergency button to the ON position and restart the engine

### Testing the machine functions

- Do not activate the movement enable key. Activate each of the platform and boom functions buttons: the boom and platform functions must not be operative.
- Activate the movement enable key and activate each of the boom and platform functions buttons: all the platform and boom functions must be operative for a complete cycle.

### Auxiliary pump test

- Press the red emergency stop button: reset it to stop the I.C. engine.
- Activate the auxiliary pump and test the movements of the booms and platform.

**NOTE: to avoid consuming the batteries, limit the test duration time.**

- After confirming the correct working , deactivate the auxiliary pump and restart the I.C. engine.

### Testing the warning sound

- Press the yellow button of the warning sound and check its working.

### Checking the errors

- Select from the control panel the alarm pages and check for the absence of alarms.
- If this is not the case, immediately proceed with solving the problem.

### 3.3.2 Controls on the platform

- Position the key-operated switch of the trucks control panel on the controls in the platform and start up the I.C. engine.

### Emergency stop test

- Press the red emergency stop button on the platform by turning it to the OFF position: the engine must switch off and no function can be operative
- Turn the red stop emergency button to the ON position and restart the engine.

### Testing the pedal switch

- Press the red emergency stop button on the controls in the platform, bringing it to the OFF position.
- Turn the red emergency button to the ON position.
- Press the pedal switch and try to start up the engine: if everything works correctly, the engine will not start up.
- Do not press the pedal switch down and start up the engine: if everything works correctly, the engine will start up.
- Do not press the pedal switch down and test each function of the machine: none of the functions must be operative.

## Pre-operative inspections

### Testing the machine functions

- Do not press the movement enable pedal. Activate the functions of the joysticks for movement and telescopic booms: the functions must not be operative.
- Press the movement enable pedal and act on the joysticks: the functions must be operative.

### Auxiliary pump test

- Press the red emergency stop button: reset it to stop the I.C. engine.
- Activate the emergency pump and test the movements of the booms and platform.

**NOTE: to avoid consuming the batteries, limit the test duration time.**

- After confirming the correct working, deactivate the auxiliary pump and restart the I.C. engine.

### Testing the steering methods



- Operate on the selector concerned and check the working of the three types of steering of the wheels.

### Testing the warning sound

- Push up the switch of the warning sound and check its working.

### Testing the selection of the movement speed

It is possible to select mainly 2 speeds from the control panel on the platform:

- high movement speed (represented by the hare ) of 5 km/h that can only be activated with the primary telescopic boom completely lowered and retracted;
- low movement speed (represented by the tortoise ) of 1 km/h, that can be activated with the boom in the operating position.
- The third option makes it possible to overcome small obstacles keeping the transfer speed minimum but with the engine rpm

maximum to impress all the power on the drive wheels.

The high/low movement speed can be selected not only by the selector mentioned but also electronically by means of software installed on the truck: as soon as the primary telescopic boom moves from the completely lowered, retracted position, the electronic control automatically activates low speed to protect the operators on board.

At the end of the electronic control tests, proceed as described below.

- Select the maximum movement speed; with the primary telescopic boom lowered and retracted slowly activate the movement: the truck moves at a speed of 1.4 m/s (5 km/h).
- With the primary telescopic boom in the completely lowered and retracted position, lift it by 10° and slowly activate the movement: the truck must not exceed a speed of 30 cm/s (1 km/h).
- Restore the boom to the completely lowered hold position.
- With the primary telescopic boom in the completely lowered and retracted position, extend it by 1.00 m and slowly activate the movement: the truck must not exceed a speed of 30 cm/s (1 km/h).
- Restore the boom to the completely lowered hold position.
- If the movement speed with the primary telescopic boom raised and extended exceeds 30 cm/sec (1 km/h), stop the truck immediately and call an authorised service centre.

### Testing the movement and braking

- Press the pedal switch down.
- Slowly move the movement control knob in the direction indicated by the black arrow on the control panel until the machine starts moving, then restore the knob to the central position.

## **Pre-operative inspections**

- Result: the machine must move in the direction shown by the black arrow on the truck then stop suddenly.
- Slowly move the movement control knob in the direction indicated by the black arrow on the control panel until the machine starts moving, then restore the knob to the central position.
- Result: the machine must move in the direction shown by the white arrow on the truck then stop suddenly.

**Note: the brakes must keep the vehicle stationary on the maximum slope that can be travelled by the vehicle.**

---

## Pre-operative inspections

### 3.4 operating instructions



#### Do Not Operate Unless:

- ☑ Before using the machine, it is necessary to understand and apply the fundamental principles regarding the working of the machine in the safety conditions contained in this Operator's Manual.
- 1 Avoid hazard situations.
  - 2 Always carry out the pre-operative inspection.
  - 3 Check the work area.
  - 4 Always carry out functional test before using the machine.
  - 5 Use the machine only for the purposes for which it is designed: operating instructions.

#### Fundamental elements of operating instructions

The machine described in this Manual is designed to lift persons, tools and equipment within the maximum capacity allowed by the platform to the working positions, only for working from the platform. Access to the platform is allowed only from the ground through the entrance gate.

Any method or condition of use outside the limits of use described or not envisaged by the Manufacturer is strictly forbidden.

Only trained and authorized personnel should be permitted to operate a machine. If more than one operator is expected to use a machine at different times in the same work shift, they must all be qualified operators and are all expected to follow all safety rules and instructions in the operator's manual. That means every new operator should perform a pre-operation inspection, function tests, and a workplace inspection before using the machine.

## Pre-operative inspections

### 3.5 Emergency Stowing

Just when there is some failure warning except deadly security alarm and the platform has to be lowered or loaded, push Bypass Switch up and hold on, and then activate the footswitch and corresponding switch to complete it.

The fault is divided into three classes: class A/B/C. Different class, different emergency stowing procedure.

#### Class A

No	Fault	Description
1	Load sensor fault	/
2	Angle sensor fault	After the main arm angle failure, because the actual main arm angle cannot be detected, the folding arm of the folding arm model needs to be confirmed in the quick setting interface of the display screen that the main arm is less than 30 degrees (switch the main arm less than 30 ° confirmation option to ON). For specific operations, please refer to the operation section of the ground control panel display.
3	Length sensor fault	Because the length of the boom cannot be monitored timely, when there is length sensor fault, so that the boom completely retracted should be confirmed at the diagnostic panel when retracting boom. (Switch the option for main boom retracted to on.) Refer to diagnostic panel for more information.
4	Platform angle sensor fault	/
5	Jib levelling angle sensor fault	/
6	Chassis inclining sensor fault	/
7	Power on self test fault	/
8	Pedal switch and redundancy fault	/
9	Differential lock feedback fault	/

Lower the platform as the follow procedure when there is one fault or more belonging to class A.

#### Lowering platform procedure for class A fault

Order	condition	permitted operation
1	Jib operation would be valid at any location.	jib lifting up and down
		jib extending and retracting(for BT30RT/BT26RT)

**Pre-operative inspections**

		jib levelling up and down
		platform rotation
		platform levelling up and down
2	Lower the platform after completing step 1	main boom retracting
3	Retract main boom completely after step 2	main boom lifting down
		turret rotation
		Move forward and backward

**Class B**

No	Fault	Restriction logic
1	Moving joystick fault	<ol style="list-style-type: none"> <li>1 Restrict moving, showing code 46.</li> <li>2 Moving joystick initialization fault after restarting up system, restrict moving and show code 36.</li> </ol>
2	Main boom telescopic joystick fault	<ol style="list-style-type: none"> <li>1 Restrict main boom telescopic operation, showing corresponding faulty code.</li> <li>2 Telescopic joystick initialization fault after restarting up system, restrict telescopic and show code 36.</li> </ol>
3	Main boom lifting joystick fault	<ol style="list-style-type: none"> <li>1 Restrict main boom lifting operation, showing corresponding faulty code.</li> <li>2 Lifting joystick initialization fault after restarting up system, restrict lifting and show code 36.</li> </ol>
4	Jib lifting joystick fault	<ol style="list-style-type: none"> <li>1 Restrict jib lifting operation, showing corresponding faulty code.</li> <li>2 Jib lifting joystick initialization fault after restarting up system, restrict jib lifting and show code 36.</li> </ol>
5	Turret rotation joystick fault	<ol style="list-style-type: none"> <li>1 Restrict turret rotation, showing corresponding faulty code.</li> <li>2 Turret rotation joystick initialization fault after restarting up system, restrict turret rotation and show code 36.</li> </ol>

---

## Pre-operative inspections

### Class C

No	Fault	Restriction logic
1	PVG fault	1 No restriction. 2 Show corresponding faulty code.
2	jib retraction limiting fault (only for BT30RT/BT26RT)	1 Show code 91 when moving. 2 High speed mode cannot be chosen.
3	chains broken switch	Restrict main boom extending out, showing code 51.
4	engine fault	1 No restriction for operation system. 2 Show corresponding faulty code.

Lower the platform by activating bypass button on ground console or platform console, and then operating corresponding operation, when there is one fault or more belonging to class B or class C.

## **4. Operation**

# Operation

## 4.1 Ground control panel

The ground control panel is only used for mobile platforms for inventory and operational testing. The ground control panel can be used to rescue people who cannot move on the platform in an emergency. After turning on the ground control panel, the platform controls will be disabled except for emergency braking.

The ground control panel is installed in a special reversible box located next to the fuel tank (left side of the machine). To open it, press the lock as shown in the figure below, operate and open the two handles, and then raise the lower control box.

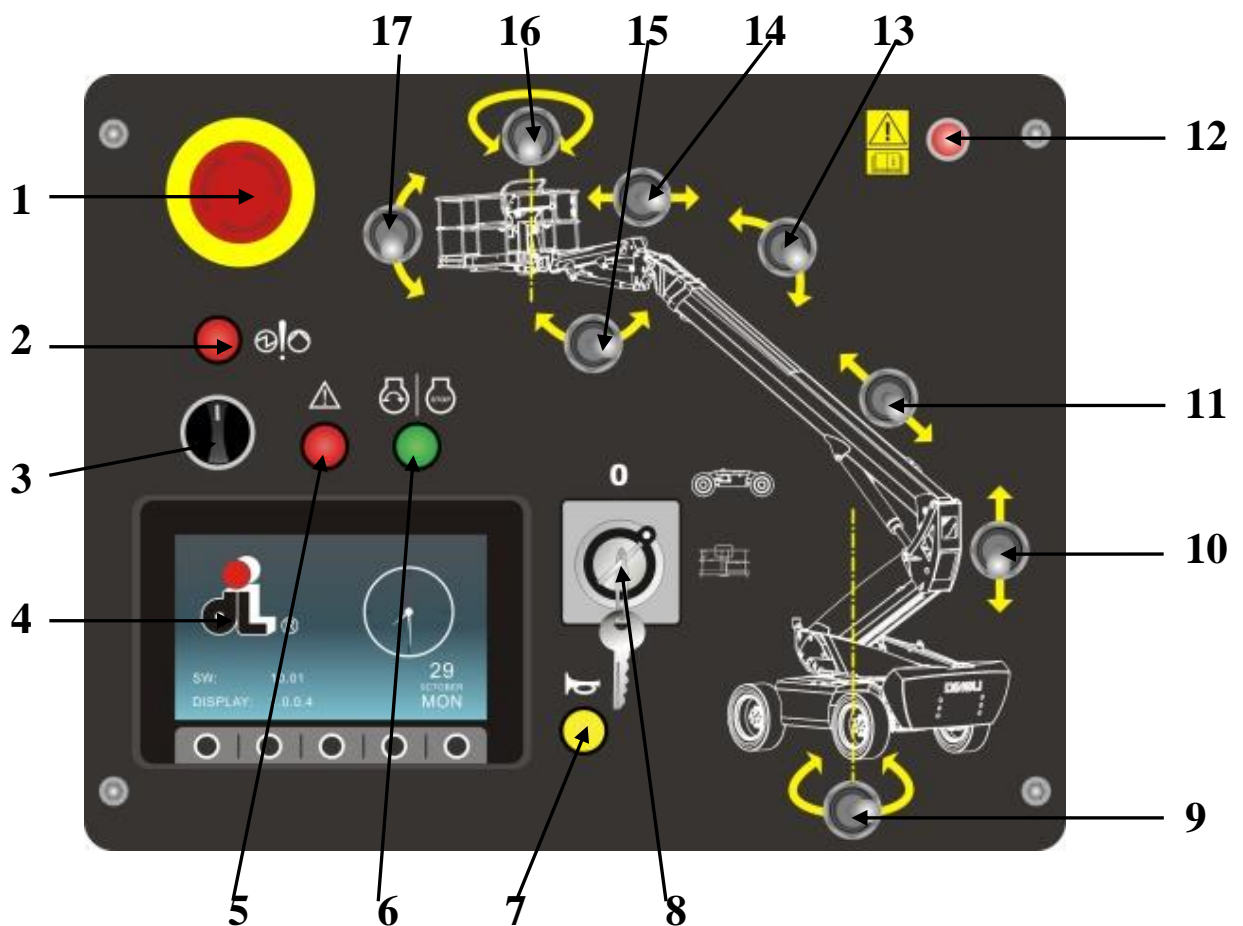

## Operation

### 1 Red emergency stop button

To stop all the functions and switch off the engine, press down the red emergency stop button. To activate the machine, pull the red emergency stop button to the ON position by turning it clockwise.

### 2 Auxiliary power supply button

Use the auxiliary power supply in case of a fault in the main power supply (I.C.engine). Press down the button to activate the auxiliary power supply, and then set the platform in safety condition.

### 3 Movement enable key

**To enable the hydraulic movements from the control panel on the ground, turn the key clockwise and hold it in this position.**

### 4 Diagnostics panel



This panel contains the basic information for monitoring the working of the truck. The pages and options available are displayed in the lower part of the screen [A] and are controlled by the corresponding buttons present below [B].

#### Main page

The upper band shows:

- alarm indicator light;
- battery electric voltage low indicator light;
- engine spark plugs preheating indicator light;
- steering mode selection indicator light;
- parking brake active indicator light;
- work lights active indicator light;
- engine oil level low indicator light;
- differential block active indicator light;
- front axle block active indicator light;
- cooling fan inversion active indicator light;
- movement speed selection indicator light: slow/fast;
- controls position indicator light: ground/basket.

The central band shows:

- the motor rev counter to the LH,
- the number of working hours in the centre, the batteries voltage, the fuel level and the code of the faulty of the engine;
- The engine oil pressure indicator and the engine water temperature indicator on the RH.

The bottom band shows the indications of the pages that can be consulted:

- engine data (rpm, drive torque percentage measured, coolant temperature, oil pressure, engine consumption measured, instant and maximum fuel consumption, operating hours, quantity of fuel used, required engine speed);
- operational data (angular inclination of boom, angular inclination of secondary boom, angular inclination of JIB, inclination of the platform, inclination of the truck on the horizontal plane, hydraulic fluid temperature, load measured on platform);
- options settings (activation/deactivation of basket safety system, cooling fan inversion activation/deactivation, transport mode activation/deactivation; engine compartment hood micro switch activation/deactivation; telescopic boom closure confirmation activation/deactivation.)

# Operation



The setting interface could be entered by depressing setting button and hold on for one second. The optional function can be turned on or off without password, after entering setting interface. The procedures are as follows:

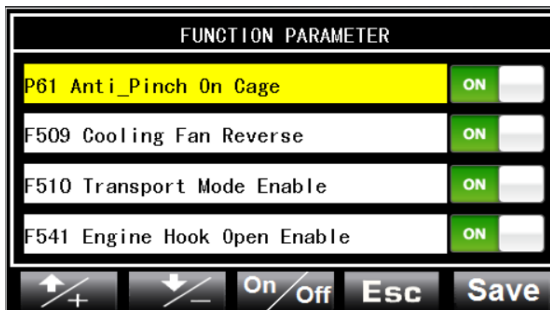

- A Depressing or is used to choose the item separately. For example "P61 Anti\_Pinch On Cage", "F509 Cooling Fan Reverse", "F510 Transport Mode Enable" and "F541 Engine Hook Open Enable". The chosen item would be shown in yellow background;
- B Depressing and holding on is used to turn on or off corresponding function;
- C Save the modified value by depressing the button ;
- D Modifying "P61 Anti\_Pinch On Cage", "F509 Cooling Fan Reverse", "F510 Transport Mode Enable" and "F541 Engine Hook Open Enable", is only valid in condition of power on. It will return back at the moment of interruption of power supply;
- E It returns back to main interface, when the button is depressed;

**NOTE: : The modification of transport mode would be invalid at the moment of one of the following being activated.**

- ✓ Platform control is chosen.
  - ✓ The degree of chassis inclining exceeds 5.
  - ✓ The angle of main boom lifting exceeds 20.
  - ✓ Main boom extends more than one meter.
    - exit button
    - MENU button
- 5 Basket signal bypass selector
 

To enable movements from the control panel on the ground with the red emergency button pressed from the platform, keep the selector enabled together with the enable key activated and the movement selectors concerned.
  - 6 Engine start-up button
 

Press the green button to start up/switch off the engine.
  - 7 Acoustic warning button
 

To activate the acoustic signal press the yellow button.
  - 8 Key-operated switch
 

With the key in position 0 the truck is switched off: in another position, if brought to 0 the electric circuit closes, switching off the truck.

To activate the controls on the ground, turn the key-operated switch to the icon representing the truck. To activate the controls in the platform, turn the key-operated switch to the position representing the platform.
  - 9 Turret rotation selector
 

To rotate the turret counter clockwise, turn the selector to the LH.

To rotate the turret clockwise, turn the selector to the RH.
  - 10 Primary telescopic boom lift selector
 

To lift the primary telescopic boom, move the selector forwards.

To lower the primary boom, move the selector backwards.
  - 11 Primary telescopic boom extension selector

---

To extend the primary boom, turn the selector to the LH.

To retract the primary boom, turn the selector to the RH.

#### 12 Red indicator light

The red indicator lights up in condition of the truck being dangerous or in case of the truck being in mechanical faulty. (together with the specific signal)

In this situation, stop the vehicle after lowering the platform and check the signals highlighted on the diagnostics panel.

#### 13 Secondary telescopic boom lift selector

To lift the secondary boom, turn the selector to the LH.

To lower the primary boom, turn the selector to the RH.

#### 14 Second telescopic boom extension selector

To extend the second boom, turn the selector to the LH.

To retract the primary boom, turn the selector to the RH.

#### 15 Jib levelling selector

To level up jib, turn the selector up, otherwise, turn it down.

#### 16 Platform rotation selector

To rotate the platform counter clockwise, turn the selector to the LH.

To rotate the platform clockwise, turn the selector to the RH.

#### 17 Platform levelling selector

To level up the platform, move the selector upwards.

To lower the platform, move the selector downwards.

# Operation

## 4.2 Control panel on platform

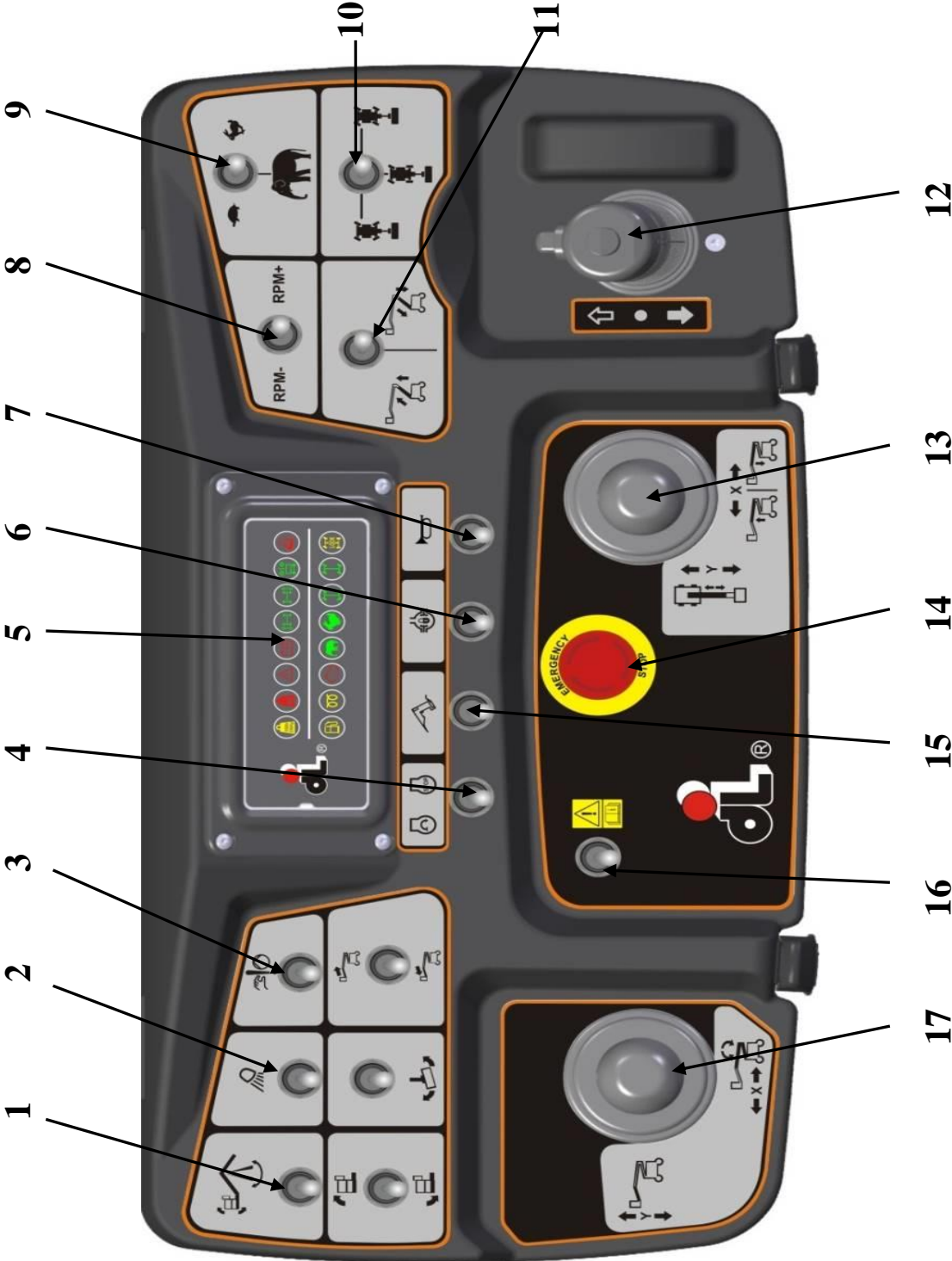



**To impart the platform**

**commands, press the movement enable pedal present on the platform.**

**1 Levelling the jib**

When the secondary boom exceeds the horizontal levelling limit in positive or negative, Push the toggle up or pull down and then hold on to recover the correct position. When the operation is complete, the red indicator and emergency warning sound are deactivated.

**2 Work lights**

Activate the selector to switch on the work lights fitted on the structure.

**3 Auxiliary pump**

Use the emergency power supply in case of a fault in the main power supply (I.C.engine).  
Act on the selector for activation.



**Extended use will affect the battery charge: only use in case of emergency.**

**4 Engine start up**

Activate the selector to start up/switch off the I.C. engine.

**5 Indicator lights panel**

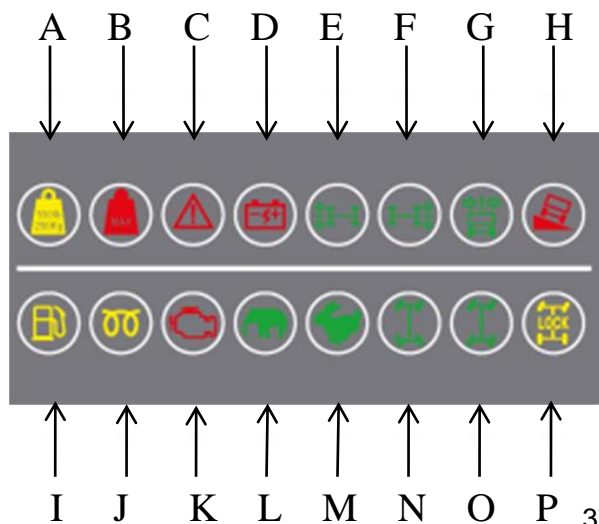

**A. Load indicator on platform**

The yellow indicator lights up to indicate that the load in the platform has exceeded the permitted load when the platform is at the permitted location.

**B. Maximum load indicator**

The red indicator lights up to indicate that the load in the platform has exceeded the maximum permitted load.

**C. Generic hazard indicator**

The red indicator lights up in hazard conditions of the truck (together with the specific signalling) or in case of mechanical fault of the truck. In this situation, stop the vehicle after lowering the platform and check the signals highlighted on the diagnostics panel.

**D. Batteries low voltage indicator light**

The red indicator light switches on when the battery voltage level is below the threshold allowable for the correct working of the truck. In this situation, the operators must get down and charge it.

If the indicator still lights up after completing charging it, the battery should be checked or replaced.

**E. Front axle wheels alignment**

The green indicator light indicates the alignment of the front axle wheels with the truck axis.

**F. Rear axle wheels alignment**

The green indicator light indicates the alignment of the front axle wheels with the truck axis.

**G. Turret/telescopic boom alignment**

The green indicator light indicates the

## **Operation**

alignment of the turret/telescopic boom with  
the truck axis.

**H. Roll-over indicator light**

The red light indicates that the maximum slope with respect to the horizontal plane of the platform is reached. The side shift function in one or both directions will not be operational.

Only movements for restoring safety and levelling to the vertical plane are enabled.

**I. Fuel level indicator**

The yellow indicator lights up to indicate low fuel level.

**J. Spark plugs pre-heating**

The orange indicator lights up to indicate pre-heating of the spark plugs for powering the electrical system.

Wait for this to be switched off to start-up the engine.

**K. Engine fault**

The red light indicates a fault in the I.C. engine. Stop the vehicle and check the engine parameters from the panel present on the truck in the tanks compartment.

**L. ELEPHANT drive mode**

The green light indicates activation of the transfer mode for moving over sloping sections.

**M. HARE drive mode**

The green light indicates activation of the transfer mode at maximum speed.

**N. Round steering mode**

The green light indicates selection of steering mode with opposite axles to reduce the steering radius on the ground.

**O. Crab steering mode**

The green light indicates selection of steering mode with the axles parallel for lateral movements.

**P. Differential block**

The yellow light indicates activation of the differential block.

**6 Differential block**

Keeping the selector activated activates the differential block, increasing the traction of the wheels on the rear axle



**7 Warning buzzer**

Use the selector to activate the acoustic signal.

**8 Engine rpm control**

Activating the selector will increase [+] or decrease [-] the engine rpm.

**9 Speed selector**

- Position  : low speed,
- Position  : low speed with high rpm of engine because level differences are exceeded.
- position  : high speed.

The movement speed is controlled by the position of the primary telescopic boom: high speed can only be used: with controls from the platform, with boom completely lowered, retracted and with turret rotation centred. As soon as one of the conditions described above is not respected, the speed changes automatically to slow.

**10 Steering mode selector**

- axles with round steering;
- only steers the front axle;
- axles with parallel steering.

**Note: The four wheels should be at original position before changing the steering mode.**

**11 Primary telescopic boom**

Not used.

**12 Lateral movements of the truck**

To activate the joystick commands press the enable pedal on the platform as well as the enable button present on the front of the joystick.

To move the truck forwards/backwards, move the joystick on the vertical axis.

To pilot the steering, act on the selector provided at the top of the joystick.

## Operation

### 13 Primary telescopic boom movement

Move the joystick in both horizontal directions to extend/retract the primary boom.

Move the joystick in both vertical directions to raise/lower the primary boom.

### 14 Red emergency stop button

To stop all the functions and switch off the engine, press the red emergency stop button

To activate the machine, set the red emergency stop button to the ON position by turning it clockwise.

### 15 Hydraulic generator ( optional)

When present, the selector activates the power socket on the platform to power up the work tools.

### 16 Basket signal bypass selector

To enable movements from the control panel on the platform when something wrong with the machine happened, keep the selector enabled together with the enable key activated and the movement selectors concerned.



**Note: Just when there is some**

**failure warning except deadly security alarm, and the machine has to be moved or loaded, the switch can be used to do, while the persons in the platform and around the machine are safe. Arbitrary usage of the switch will result in damage and serious injury.**

### 17 Turret rotation /secondary boom lifting

Move the joystick in both horizontal directions to rotate the turret.

Move the joystick in both vertical directions to raise/lower the secondary boom.

### 18 Secondary telescopic boom (if present)

Move the selector in both vertical directions to control the extension of the telescopic JIB.

### 19 Platform rotation

Move the joystick in both horizontal directions to rotate the platform.

### 20 Levelling the platform

Use the selector to correct the horizontality of the platform manually.

### 4.3 Transportation notice



Setting the machines in safety correctly and choosing appropriate transport means according to the provisions of the Ministry of Industry and Public Transport, the regulatory standards in force and the corporate policies are solely the responsibility of the owner of the machine.

DingLi provides the following information regarding the handling and transport of the machine only as recommendation.

- Loading and unloading the machine from a transport vehicle must be done solely by operators skilled in lifting operations.
- Make sure the load capacity of the vehicle, the loading surface, the chains or blocking devices are capable of supporting the machine weight. For the machine weight, refer to the technical data shown on the ID plate of the machine model.
- Make sure the rotation block of the slewing ring gear positioned on the RH side of the turret is activated and turret is locked before proceeding with transport.



- Release the slewing ring gear before restoring the working of the machine.
- Check for the presence of any mobile objects on the platform and remove these if necessary.

### 4.4 Blocking the chassis



Use all four fixing devices provided on the chassis according to the diagram shown above.

## Operation

### 4.5 Blocking the platform

Fold the platform using the transport mode that can be selected from the control panel on the truck: this option eliminates the operating constraints of the machine, making it possible to fold the telescopic boom back.

If the boom cannot be folded, make sure the primary and secondary parts are completely retracted and that none of the parts touch the loading surface; place the platform on the loading deck and secure it in place on the transport bed using nylon belts.

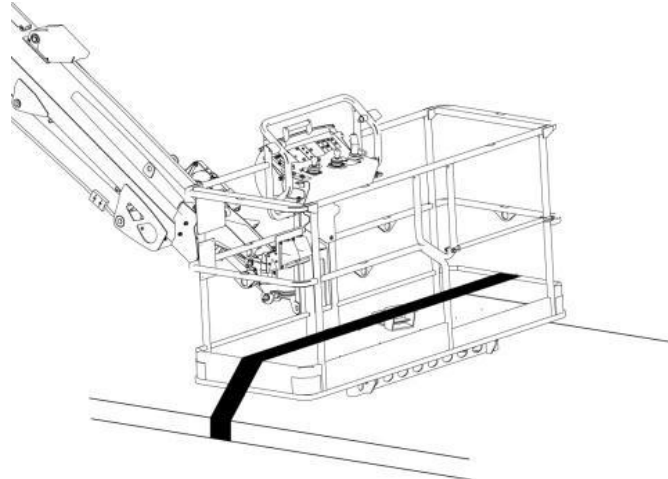

### 4.6 Towing the vehicle



---

**Towing the vehicle using an incorrect procedure can cause serious accidents.**

**Before disengaging the negative brake manually, block the machine to prevent its movement.**

**Follow the instructions given below to tow the machine correctly.**

---

A faulty machine can only be towed for short distances and at speeds not exceeding 10km/h. If necessary, to transport the vehicle over longer distances and at greater speeds, use a suitable vehicle for transport.

Before towing the vehicle, retract and lower the telescopic boom completely and remove the load.

Do not use chains for towing the machine. Use steel cables with rings at the ends, or a special rigid tow bar. Make sure the cable is in good condition. Make sure the cable has a nominal carrying capacity 1.5 times the weight of the vehicle to be towed.

Connect one end of the cable to the two front eyelets on the towing vehicle. Connect the other end of the cable to the two front eyelets of the vehicle to be towed.

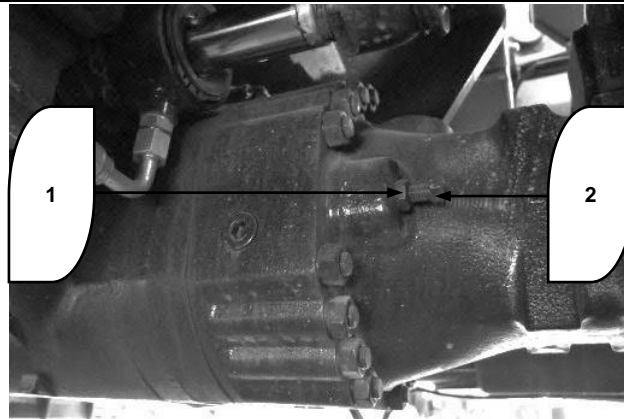

Go under the vehicle near the rear axle. Unscrew lock nut 1 of power screw 2. Tighten the power screw to fit flush to disengage the negative command brake. Repeat the operation for both screws on the same axle. And then repeat the operation for front axle.

Remove the hoses from the port A and B of the driven pump and then connect two ends of the hoses removed together after completing releasing brake.

Have an operator climb on the machine to be towed to control the braking and steering. An observer must stand in a safe position to check the outcome of the operations. The observer must not stand on the vehicle to be towed.

Tighten the tow cable slowly. Avoid sudden movements to avoid overload on the cable. Keep the angle between the machine and the towing cable minimum; it must not exceed  $30^{\circ}$  in any case whatsoever.

Because of the impossibility of listing all the precautions and towing procedures for all the situations, it is advisable to consult your Dealer for assistance.

# Operation

## 4.7 Lifting

Use only devices suitable for the movement concerned: make sure the capacity of the lifting crane, chains, ropes and relative hooks are able to support the weight of the machine; to check the data, consult the manufacturer's ID plate affixed on the chassis.

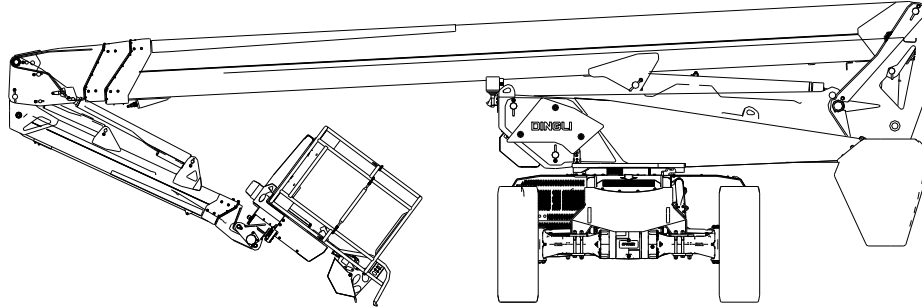

Adjust the lifting devices in such a way as to keep the machine level and without causing damage to it.

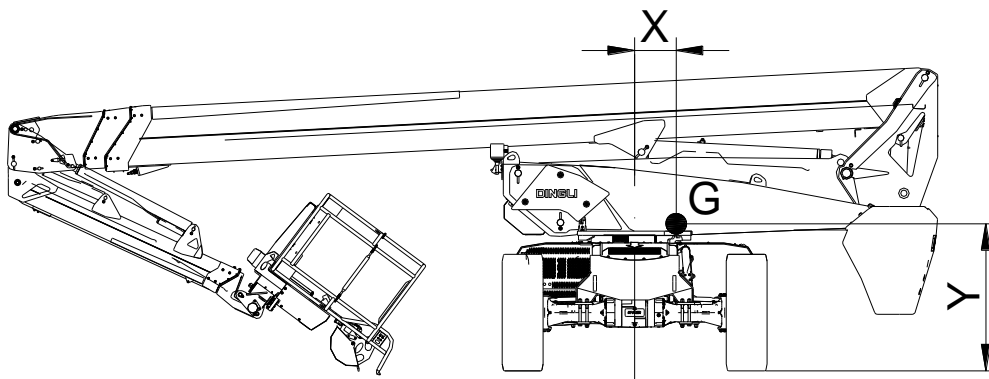

### Centre of gravity

Model	X (mm)	Y (mm)
BT30RT	519	1111
BT28RT	594	1102
BT26RT	550	1074
BT26SRT	545	1074
BT24RT	534	1074

**Note: The centre of gravity of every machine is not accurate but recommendation.**

## **5. Display interface**

## Display interface

### 5.1 Boot interface

When the system is powered on, the display will show "DINGLI" Logo, arm model, software version, date and other information, and after maintaining for 1-2 seconds, the system enters self-test mode;



MACHINE: arm model;

SW: software version;

DISPLAY: Display version;

Others: "DINGLI"Logo, date, week and other information;

### 5.2 Home interface

#### 5.2.1 Home interface button definition





F1 Engine status button (Press valid)	Enter the engine status monitoring screen, such as speed, torque, fuel efficiency, etc .
F2 Vehicle status information button (Press valid)	Enter vehicle condition, such as main arm angle, chassis angle, main arm length, etc .
F3 Vehicle general setting button (Press and hold for 1s)	Enter the vehicle quick setting interface, without password, you can modify the platform anti-extrusion, fan work in reverse, loading, engine gantry switch and other modes;
F4 Exit button (Press valid)	When entering the engine or vehicle status interface, press the esc button to return to the main interface;
F4 Prompt cache button (Press and hold for 1s)	Press and hold for more than 1 second to enter the interface of prompt message, which is convenient for customers to view the 10 groups of action limit prompts in the most recent period;
F5 Main menu button(Press valid)	Enter the directory interface

## Display interface

### 5.2.2 Home interface icon definition

After the self-test, when the system has no alarms, the display is as follows:

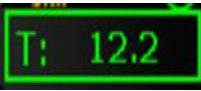

Icon	description
	Display machine engine real-time speed 0--4000rpm
	Display machine engine refueling pressure 0--10 bar Display machine engine cooling water temperature -20--120 °C
	The real-time battery voltage of the machine, unit: volt; when the engine has many faults, the engine fault code is displayed cyclically in this area; when the engine has no alarm, the battery voltage is displayed;
	Cumulative working time of the machine, unit: hour
	The real-time fuel percentage of the machine shows that when the oil level is in the red position, the machine will have a low fuel level alarm.
	Deutz bus engine fault status interface, send SPN and FMI, when the engine has multiple faults, the engine fault code is displayed cyclically; for the specific fault code, please refer to the Deutz engine fault code table. When the engine has no alarm, the battery voltage is displayed.

## Display interface



The above icons change according to the actual state of the vehicle;

 No alarm in the system	 System alarm	
 Engine generator power supply	 Battery powered	
 Engine pre-heating not work	 Engine pre-heating work	
 U-turn	 Crab steering	 Front wheel steering
 Brake off	 Brake on	
 Light off	 Light on	
 Normal engine refueling pressure	 Low engine refueling pressure	
 Differential work off	 Differential work on	
 Float axle lock	 Float axle open	
 Fans turn off in reverse	 Fans turn on in reverse	
 Slow speed	 Fast speed	
 Platform working	 Chassis working	

### 5.3 Engine status interface

F1 Engine status button (press effective)

ENGINE SPEED	2000 rpm
ACTUAL PERCENT TORQUE	80 %
COOLANT TEMPERATURE	85 °C
OIL PRESURE	123 KPa
ENGINE FUEL RATE	12.3 L/h
ENGINE FUEL AVERAGE	12.3 L/h
ENGINE HOURS	0.3 h
TOTAL FUEL USED	234.5 L
REQUEST SPEED	2000 rpm
<div style="display: flex; justify-content: space-between; width: 100%;"> <span>Engine</span> <span>Data</span> <span>Set</span> <span>ESC</span> <span>Menu</span> </div>	

Enter the engine status monitoring screen, such as speed, torque, fuel efficiency, etc.

### 5.4 Vehicle condition interface

MAIN BOOM ANGLE	12.3 °
MAIN BOOM LENGHT	0.123 m
JIB ANGLE	12.3 °
CAGE ANGLE	12.3 °
CHASSIS TILT ANGLE X	12.3 °
CHASSIS TILT ANGLE Y	12.3 °
HYDRAULIC TEMPERATUR	60 °C
CAGE LOAD	120 Kg
BT30 LOADCHART	450 Kg
<div style="display: flex; justify-content: space-between; width: 100%;"> <span>Engine</span> <span>Data</span> <span>Set</span> <span>ESC</span> <span>Menu</span> </div>	

F2 Vehicle status information button (press effective)

Enter vehicle condition, such as main arm angle, chassis angle, main arm length, etc.



### 5.5 Vehicle quick setting interface (No password required)

F3 Vehicle general setting button (Press and hold for 1s)

Enter the vehicle's quick setting interface, without password, you can modify the platform anti-extrusion, fan work in reverse, loading, engine gantry switch, etc.

FUNCTION PARAMETER	
P61 Anti_Pinch On Cage	ON <input type="checkbox"/>
F509 Cooling Fan Reverse	ON <input type="checkbox"/>
F510 Transport Mode Enable	ON <input type="checkbox"/>
F541 Engine Hook Open Enable	ON <input type="checkbox"/>
<div style="display: flex; justify-content: space-between; width: 100%;"> <span>↑ +</span> <span>↓ -</span> <span>On/Off</span> <span>Esc</span> <span>Save</span> </div>	

FUNCTION PARAMETER	
F600 Main Boom Retract Confirmed	ON <input type="checkbox"/>
F602 Lower Boom Retract Confirmed	ON <input type="checkbox"/>
F603 Main Boom Angle <30° Confirmed	ON <input type="checkbox"/>
<div style="display: flex; justify-content: space-between; width: 100%;"> <span>↑ +</span> <span>↓ -</span> <span>On/Off</span> <span>Esc</span> <span>Save</span> </div>	

1. Press  and  button to switch to modify the parameter list, the selected parameter has a yellow background;
2. Press  button and hold it for 1 second, it is effective for turning on or off the corresponding parameter function;

## Display interface

3. Press **Save** button to save the modified value; only for "P61 platform anti-squeeze switch" and "P327 engine fan reverse", after saving successfully, it is valid even if the power is turned off;
4. "F509 engine fan reverse", "F510 loading mode (condition satisfied)", "F541 engine gantry switch" and "F600 main arm fully retracted confirmation (used to safely close the vehicle)", only for the system power-on state, Modified parameters are valid. When the power is off, the modified parameters are still in the OFF state;
5. Press the **Esc** button to return to the main interface.

### 5.6 Prompt cache button

F4 Press and hold for more than 1 second to enter the prompt message interface, which is convenient for customers to view the 10 sets of action limit prompts in the most recent period;

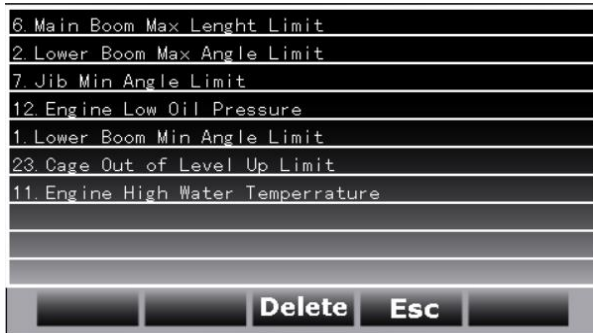

1. Press the **Delete** button and keep it valid for 1 second to clear the cache of prompts;
2. Press the **Esc** button to return to the main interface;

### 5.7 Alarm/warning interface (Automatic switching)

When the system has an alarm or warning, the display will automatically switch from the main interface to the alarm / warning interface;



1. In this interface, press the **Engine** button or **Data** button, you can view the engine and vehicle working condition information, but you cannot return to the main interface;
2. When there is no alarm or warning in the system, the display will automatically return to the main interface;
3. When multiple alarms or warning occur, the message can be displayed cyclically;

## 5.8 Main menu



1. From the F5 button **Menu** on the main interface (press valid), enter the menu interface;
2. Press **↑+** and **↓-** button to switch the directory list, the selected item is indicated by green arrow **→**;
3. Press the **Home** or **Esc** button to return to the main interface;
4. Press the **←** button to enter the corresponding options, such as diagnosis, tool setting interface, etc.

### 5.8.1 Diagnose interface



1. Select the diagnostic interface from the menu interface and press the **←** button to enter;
2. Press **Home** to return to the main interface;
3. Press **Esc** the button to return to the directory interface.

**See the next chapter for details**

## Display interface

### 5.8.2 Tools interface



1. Press and button for tool option list;
2. Press to return to the main interface;
3. Press the **Esc** button to return to the directory interface;
4. Press the button to enter the corresponding tool options, such as backlight, clock setting, etc.

Interpretation of tool interface icons			
Backlight setting is not enabled	Backlight setting is enabled	Clock setting is not enabled	Clock setting is enabled
not used	not used	not used	not used
Language setting is not enabled	Language setting is enabled		

#### 5.8.2.1 backlight setting interface

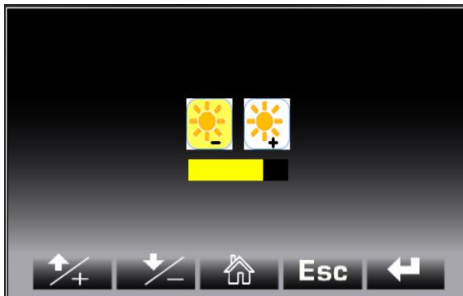

1. Press the and buttons for options, no matter which button is pressed, the backlight button cycle switch;
  2. Press to return to the main interface;
  3. Press **Esc** button to return to the tool setting interface and save the current backlight setting value;
  4. When the icon is displayed, press the button to indicate that the backlight setting is increased;
  5. When the icon is displayed, press the button to indicate that the backlight setting is reduced;
- Indicates the current backlight percentage%.

## Display interface

### 5.8.2.2 Clock setting menu



1. Press the button to select the clock object corresponding to the activated or inactive green arrow . When entering the clock setting from the tool interface, the default "hour option is activated";
2. When the font corresponding to the blue arrow changes to green 小时, press the and buttons to increase or decrease the corresponding clock value;
3. When the font corresponding to the blue arrow becomes white 小时, press the and buttons to cycle through the corresponding clock objects;
4. Press to return to the main interface;
5. Press the **Esc** button to return to the tool setting interface.

Note that when you enter the clock setting interface, the clock function stops working. You need to exit this interface for the clock to actually work.

### 5.8.2.3 Language setting interface



1. Press and button for language selection option list;
2. Press to return to the main interface;
3. Press the **Esc** button to return to the tool setting interface and save the current language setting;
4. Press the button to enter the corresponding language options, such as Italian, English, Chinese settings, etc.; the icon on the right indicates the selected language.

## Display interface

### 5.8.3 Password interface

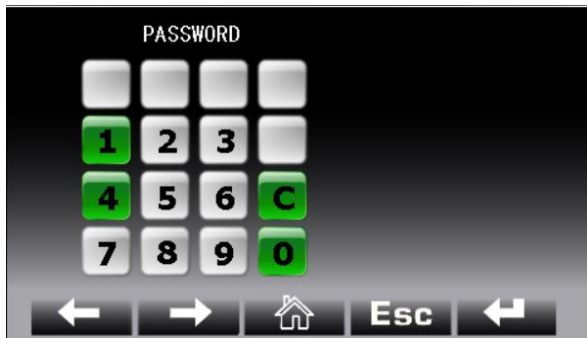

In the default state of the password interface, you need to enter a four-digit password;

1. Press to return to the main interface;
2. Press the button to return to the tool setting interface;
3. Press the button and the green background will cycle through from right to left;
4. Press the button and the green background will cycle through from left to right;
5. Press the button to indicate that the corresponding green background number is selected.

**The password is divided into two levels. The password is "xxxx" for rental customers and "xxxx" for OEM manufacturers.**

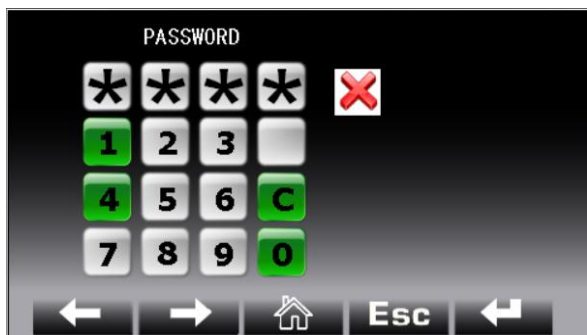

1. After the 4-digit password is confirmed, if the password is incorrect, the icon is displayed;
2. After selecting the wrong password, you need to move the cursor to the position and press the but clear the current password.

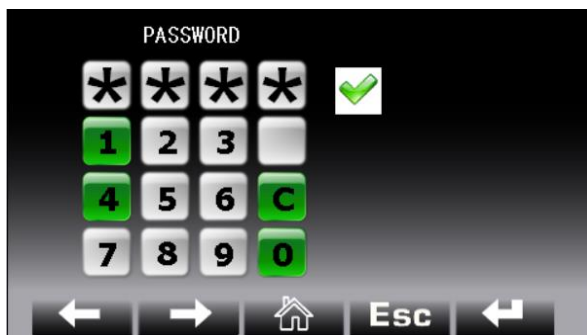

1. When the correct 4-digit password is entered, the icon is displayed;
2. After the password is entered correctly, press the button and keep it valid for 1 second to enter the fu setting interface.

## **6. Diagnose interface**

## Diagnose interface

### 6.1 Basic data

The interface displays: chassis controller software version, platform controller software version, display software version, vehicle model and compliance standard.



1. Press to return to the main interface;
2. Press the **Esc** button to return to the diagnostic interface.

### 6.2 I/O status

The controller is listed from bottom to top as the chassis and platform controller.

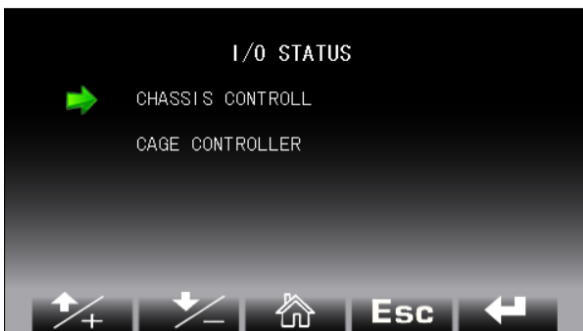

1. Press to return to the main interface;
2. Press the **Esc** button to return to the diagnostic interface.

#### 6.2.1 Chassis Controller I/O diagnose

Diagnose the information of all ports of the chassis controller.

CHASSIS CONTROLLER			
U22_Jib_Out_DI	0	S40_GND	12345
U01_Chassis_KeyDI	123	S40_GND	12345
U01_Chassis_KeyDI	12345	S40_GND	12345
S40_GND	12345	S40_GND	12345
S40_GND	12345	U24TurretRotCCW_DI	240000

1. Press and button to switch IO input and output list;
2. Press to return to the main interface;
3. Press the **Esc** button to return to the controller I/O diagnostic interface.

**Diagnose interface****Chassis MC2M interface I/O list**



<b>I/O port of U plug</b>			
U01_Chassis_KeyDI	U11_Cage_RotCCW	U21_Jib_In_DI	U31JIB_Leveling_Up
U02_Horn_DI	U12_Cage_RotCW	U22_Jib_Out_DI	U32JIB_Leveling_Dw
PinU03_Val	U13_Cage_Up_DI	U23TurretRotCW_DI	U33Turret_Left
U04_Fuel_Sensor_AI	U14_Cage_Dw_DI	U24TurretRotCCW_DI	U34Turret_Right
U05_MainBoom_Up	U15_ChassisDeadMan	PinU25_Val	U35Turret_Central
U06_MainBoom_Dw	U16_EmergencyPump	U26_Engine_RUN_IN	U36EngineAirFilter
U07_MainBoom_Out	U17_EngineOnOff	U27AxisLockLeftNO	U37FrontAxisCenter
U08_MainBoom_In	U18_ChassisBypass	U28AxisLockRightNO	U38RearAxisCenter
U09_Jib_Up_DI	PinU19_Val	U29AxisLockLeftNC	PinU39_Val
U10_Jib_Dw_DI	PinU20_Val	U30AxisLockRightNC	PinU40_Val
<b>I/O port of T plug</b>			
PinT01_Val	PinT11_Val	PinT21_Val	PinT31_Val
PinT02_Val	PinT12_Val	PinT22_Val	PinT32_Val
T03EngineStart_DO	T13Axle_DiffLockDO	T23LowerBoomUp_DI	PinT33_Val
T04EmergencyPump	T14_Buzzer_DO	T24LowerBoomDw_DI	T34LowerBoomIn_NC
T05EngineCool_DO	T15GearN_Position	PinT25_Val	T35LowerBoomIn_NO
PinT06_Val	T16HighTravelspeed	T26LowerBoomMin_NC	T36HydrOil_Temp_AI
T07GeneratorStart	T17Steering_Left	T27LowerBoomMin_NO	T37Chain_Broken_DI
T08_Overload_DO	T18Steering_Right	T28MainBoomIn_LS	T38LowerBoomMax_NO
PinT09_Val	T19Parking_Brake	T29LowerBoomMax_NC	T39MainBoomMin_NO
T10_Horn_DO	T20HydrOil_Cooling	T30HoodOpen_DI	T40MainBoomMin_NC
<b>I/O port of S plug</b>			
S01_VB+ Logic power supply positive	S11_15Vout+	S21_VB- Logic power supply negative	S31_5Vout+
S02_Uturn_mode_DO	S12_AGND	S22_Varef	S32_AGND
S03_Crab_mode_DO	S13_CoolingFan_R	S23_Can0 L	S33_DGND
S04_Beacon_DO	PinS14_Val	S24_Can0 R	S34_DGND
PinS05_Val	S15Travel_F_PWM	S25_Can0 H	S35_DGND
PinS06_Val	S16Travel_B_PWM	S26_Can1 L	S36_LIN1
S07_Can1 H	S17AxleLock_Left1	S27_Can1 R	S37_LIN0
PinS08_Val	S18AxleLock_Left2	S28_Can2 H	S38_RS232 RX
PinS09_Val	S19AxleLock_Right1	S29_Can2 R	S39_RS232 TX
PinS10_Val	S20AxleLock_Right2	S30_Can2 L	S40_GND

**6.2.2 Cage controller I/O diagnose**

Diagnose the information of all ports of the platform controller;

<b>CAGE CONTROLLER</b>			
U01TravelJoy_A11	12345	PinU07_Val	12345
U02TravelJoy_A12	12345	PinU08_Val	12345
U03_Cage_Up_DI	12345	U09CageRotLeft_DI	12345
U05Steer_Left_DI	12345	U10CageRotRight_DI	12345
U06Steer_Right_DI	12345	U11_Loadcell_A11	12345

## Diagnose interface

1. Press  and  button to switch IO input and output list;
2. Press  to return to the main interface;
3. Press the **Esc** button to return to the controller I / O diagnostic interface.

### Platform MC2M interface I / O list

I/O port of U plug			
U01TravelJoy_AI1	U11_Loadcell_AI1	U21Axle_Lock_DI	U31TurretRotJoy_AI
U02TravelJoy_AI2	U12_Loadcell_AI2	U22Jib_In_NC_LS	U32JibAmpJoy_AI
U03_Cage_Up_DI	U13LowerBoomUp_DI	U23Jib_In_NO_LS	U33BoomZoomJoy_AI
U04_CageDown_DI	U14LowerBoomDw_DI	PinU24_Val	U34BoomAmpJoy_AI
U05Steer_Left_DI	PinU15_Val	U25TravelJoy_DM	PinU35_Val
U06Steer_Right_DI	U16CagetAutoLev_DI	PinU26_Val	PinU36_Val
PinU07_Val	U17_Pedal_NC_DI	PinU27_Val	PinU37_Val
PinU08_Val	U18_Pedal_NO_DI	PinU28_Val	PinU38_Val
U09CageRotleft_DI	PinU19_Val	PinU29_Val	PinU39_Val
U10CageRotRight_DI	U20HydGeneratorDI	PinU30_Val	PinU40_Val
I/O port of T plug			
PinT01_Val	PinT11_Val	PinT21_Val	PinT31_Val
PinT02_Val	PinT12_Val	PinT22_Val	PinT32_Val
T03LMI_AlarmLED	T13Fuel_Low_LED	T23Engine_RPM+DI	T33EmergencyPump
T04LMI_WarningLED	T14CageRotCW	T24Engine_RPM-DI	T34_Horn_DI
T05_Alarm_LED	T15PreHeating_LED	PinT25_Val	T35_Jib_In_DI
T06Chassis_TiltLED	T16_Buzzer_DO	T26Engine_OnOff_DI	T36_Jib_Out_DI
T07CageRot_CCW	T17HeadLight_DO	T27Travel_Low_DI	PinT37_Val
T08F_AxleCenterLED	T18_Red_LED	T28Travel_High_DI	T38_AntiHand_NC
T09R_AxleCenterLED	T19_AntiHand_LCD	T29SteerCrab_DI	T39_AntiHand_NO
T10TurretCenterLED	T20_Green_LED	T30SteerUturn_DI	T40_Head_Light_DI
I/O port of S plug			
S01_VB+ Logic power supply positive	S11_15Vout+	S21_VB- Logic power supply negative	S31_5Vout+
S02AlternatorOnLED	S12_AGND	S22_Varef	S32_AGND
S03EngineAlarm_LED	PinS13_Val	S23_Can0 L	S33_DGND
S04Slope_LED	S14CageLivUp_DO	S24_Can0 R	S34_DGND
S05HighTravel_LED	S15CageLivDw_DO	S25_Can0 H	S35_DGND
S06UTurnSteer_LED	PinS16_Val	S26_Can1 L	S36_LIN1
S07_Can1 H	S17JibTeleOut_PWM	S27_Can1 R	S37_LIN0
S08CrabSteer_LED	S18JibTeleIn_PWM	S28_Can2 H	S38_RS232 RX
S09LockDiff_LED	S19JibAmpUp_PWM	S29_Can2 R	S39_RS232 TX
S10_Yellow_LED	S20JibAmpDw_PWM	S30_Can2 L	S40_GND

### 6.3 Sensor status

View the information of all can bus sensors or analog sensors;

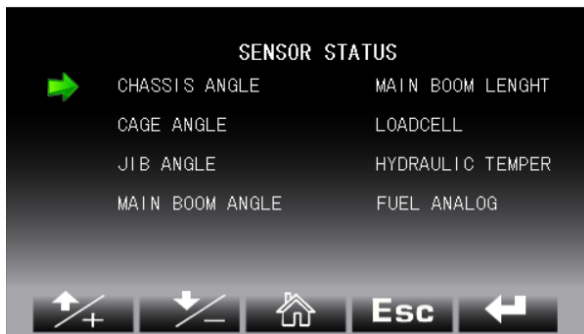

1. Press to return to the main interface;
2. Press the **Esc** button to return to the diagnostic interface.

#### 6.3.1 Chassis angle

Diagnose the information of the can bus type chassis angle sensor.

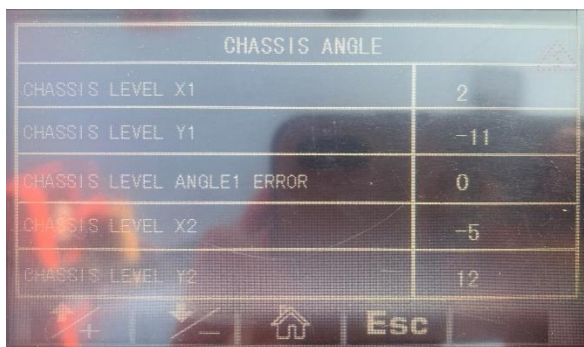



1. Press the and buttons to switch the list;
2. Press to return to the main interface;
3. Press the **Esc** button to return to the sensor status diagnosis interface.

#### 6.3.2 Cage angle (BT26S/30 valid)

Diagnose the information of the can bus type platform angle sensor.





## Diagnose interface



1. Press the  and  buttons to switch the list;
2. Press  to return to the main interface;
3. Press the **Esc** button to return to the sensor status diagnosis interface.

### 6.3.3 Jib angle

Diagnose the information of the can bus type jib angle sensor.

JIB ANGLE	
JIB ANGLE 1	1234
JIB ANGLE 1 COUNTER	1234
JIB ANGLE 1 ERROR	1234
JIB ANGLE 2	1234
JIB ANGLE 2 COUNTER	1234

   **Esc**



1. Press the  and  buttons to switch the list;
2. Press  to return to the main interface;
3. Press the **Esc** button to return to the sensor status diagnosis interface.

## Diagnose interface

### 6.3.4 Main boom angle

Diagnose the information of the can bus type main boom angle sensor.



MAIN BOOM ANGLE	
MAIN BOOM ANGLE1	1234
MAIN BOOM ANGLE 1 COUNTER	1234
MAIN BOOM ANGLE1 ERROR	1234
MAIN BOOM ANGLE2	1234
MAIN BOOM ANGLE 2 COUNTER	1234

1. Press the  and  buttons to switch the list;
2. Press  to return to the main interface;
3. Press the **Esc** button to return to the sensor status diagnosis interface.

### 6.3.5 Main boom length

Diagnose the information of the can bus type main boom length sensor.

MAIN BOOM LENGHT	
MAIN BOOM LENGTH1	1234
MAIN BOOM LENGTH2	1234
MAIN BOOM LENGTH1	1234
MAIN BOOM LENGTH1 ERROR	1234
MAIN BOOM LENGHT2 COUNTER	1234

1. Press the  and  buttons to switch the list;
2. Press  to return to the main interface;
3. Press the **Esc** button to return to the sensor status diagnosis interface.

### 6.3.6 Load cell diagnose

Diagnose the information of the load cell.

LOADCELL	
LOADCELL ANALOG	1234
LOADCELL ANALOG	1234

1. Press  to return to the main interface;
2. Press the **Esc** button to return to the sensor status diagnosis interface.

## Diagnose interface

### 6.3.7 Hydraulic oil temperature

Diagnose the information of analog hydraulic oil temperature sensor.

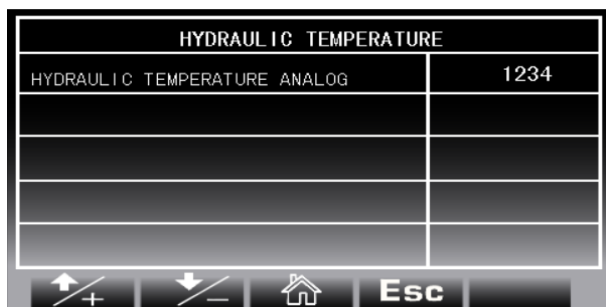



1. Press  to return to the main interface;
2. Press the **Esc** button to return to the sensor status diagnosis interface.

### 6.3.8 Fuel level gauge

诊断模拟式燃油传感器的信息。

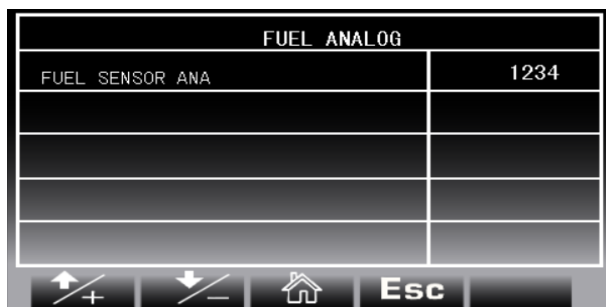
Diagnose the information of analog fuel sensor.



1. Press  to return to the main interface;
2. Press the **Esc** button to return to the sensor status diagnosis interface.

## 6.4 Engine alarm

Record the current fault records of the current 4 groups of engines. According to the fault codes of SPN and FMI, check the engine alarm message or consult the engine manufacturer to find out the specific alarm cause

SPN	FMI
100	3
102	3
105	12
6552	12

**Esc**



1. Press the **Esc** button to return to the sensor status diagnosis interface.

## Diagnose interface

### 6.5 Movement diagnose

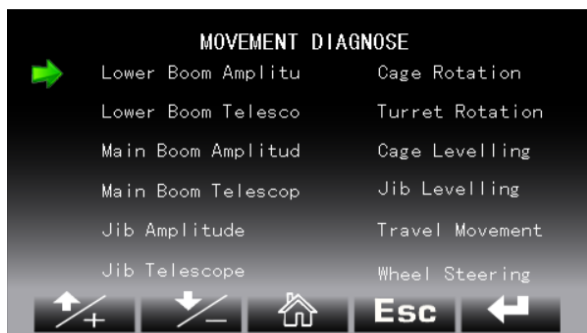
Through this interface, from the input of the handle or switch to the output of the valve block, all changes in the intermediate variables of the action can be queried.



1. Press  to return to the main interface;
2. Press  the button to return to the diagnostic interface.

**Note:** The folding arm luffing motion and folding arm telescoping motion are only for BA series models.

#### 6.5.1 Main Boom Amplitude

Main Boom Amplitude	
P540 Main BoomAmp_Jst	P550 Main Boom Amp Start Slope Min
P541 Main BoomAmp_JstCa	P551 Main Boom Amp Stop Slope Min
P542 Main BoomAmp_JstTr	P552 Main BoomAmp_Pwm
P543	P553 Main BoomAmp_PwmIn
P544	P554 Main BoomAmp_PwmZero
P545	P555 Main Boom Amp PWM Max
P546 Main BoomAmp_Rmp	P556 Main Boom Amp PWM Min
P547 Main BoomAmp_RmpIn	P557 Main BoomAmp_PwmDeadZoneA
P548 Main Boom Amp Start Slope Max	P558 Main BoomAmp_PwmDeadZoneB
P549 Main Boom Amp Stop Slope Max	P559 Main Boom Amp_PercVel

#### 6.5.2 Main Boom Telescope

Main Boom Telescope	
P560 Main Boom Tele_Jst	P570 Main Boom Tele Start Slope Min
P561 Main Boom Tele_JstCa	P571 Main Boom Tele Stop Slope Min
P562 Main Boom Tele_JstTr	P572 Main Boom Tele_Pwm
P563	P573 Main Boom Tele_PwmIn
P564	P574 Main Boom Tele_PwmZero
P565	P575 Main Boom Tele PWM Max
P566 Main Boom Tele_Rmp	P576 Main Boom Tele PWM Min
P567 Main Boom Tele_RmpIn	P577 Main Boom Tele PWM DeadzoneA
P568 Main Boom Tele Start Slope Max	P578 Main Boom Tele PWM DeadzoneB
P569 Main Boom Tele Stop Slope Max	P579 Main Boom Tele_PercVel

## Diagnose interface

### 6.5.3 Jib Amplitude

<b>Jib Amplitude</b>	
P580 Jib Amp_Jst	P590 Jib Amp Start Slope Min
P581 Jib Amp_JstCa	P591 Jib Amp Stop Slope Min
P582 Jib Amp_JstTr	P592 Jib Amp_Pwm
P583	P593 Jib Amp_PwmIn
P584	P594 Jib Amp_PwmZero
P585	P595 Jib Amp PWM Max
P586 Jib Amp_Rmp	P596 Jib Amp PWM Min
P587 Jib Amp_RmpIn	P597 Jib Amp PWM DeadzoneA
P588 Jib Amp Start Slope Max	P598 Jib Amp PWM DeadzoneB
P589 Jib Amp Stop Slope Max	P599 Jib Amp_PercVel

### 6.5.4 Jib Telescope

<b>Jib Telescope</b>	
P600 Jib Tele_Jst	P610 Jib Tele Start Slope Min
P601 Jib Tele_JstCa	P611 Jib Tele Stop Slope Min
P602 Jib Tele_JstTr	P612 Jib Tele_Pwm
P603	P613 Jib Tele_PwmIn
P604	P614 Jib Tele_PwmZero
P605	P615 Jib Tele PWM Max
P606 Jib Tele_Rmp	P616 Jib Tele PWM Min
P607 Jib Tele_RmpIn	P617 Jib Tele PWM DeadzoneA
P608 Jib Tele Start Slope Max	P618 Jib Tele PWM DeadzoneB
P609 Jib Tele Stop Slope Max	P619 Jib Tele_PercVel

### 6.5.5 Cage Rotation

<b>Cage Rotation</b>	
P620 Cage Rot_Jst	P630 Cage Rotation Start Slope Min
P621 Cage Rot_JstCa	P631 Cage Rotation Stop Slope Min
P622 Cage Rot_JstTr	P632 Cage Rot_Pwm
P623 Cage Rot_JstRa	P633 Cage Rot_PwmIn
P624 Cage Rot_JstCa2	P634 Cage Rot_PwmZero
P625	P635 Cage Rotation PWM Max
P626 Cage Rot_Rmp	P636 Cage Rotation PWM Min
P627 Cage Rot_RmpIn	P637 Cage Rotation PWM DeadzoneA
P628 Cage Rotation Start Slope Max	P638 Cage Rotation PWM DeadzoneB
P629 Cage Rotation Stop Slope Max	P639 Cage Rot_PercVel

### 6.5.6 Turret Rotation

<b>Turret Rotation</b>	
P640 Turret Rot_Jst	P650 Turret Rotation Start Slope Min
P641 Turre tRot_JstCa	P651 Turret Rotation Stop Slope Min
P642 Turret Rot_JstTr	P652 Turret Rot_Pwm
P643	P653 Turret Rot_PwmIn
P644	P654 Turret Rot_PwmZero
P645	P655 Turret Rotation PWM Max
P646 Turret Rot_Rmp	P656 Turret Rotation PWM Min

**Diagnose interface**

P647 Turret Rot_RmpIn	P657 Turret Rotation PWM DeadzoneA
P648 Turret Rotation Start Slope Max	P658 Turret Rotation PWM DeadzoneB
P649 Turret Rotation Stop Slope Max	P659 Turret Rot_PercVel

**6.5.7 Cage Levelling**

<b>Cage Levelling</b>	
P680 Cage LivUpDw_Jst	P690 Cage Level Start Slope Min
P681 Cage LivUpDw_JstCa	P691 Cage Level Stop Slope Min
P682 Cage LivUpDw_JstTr	P692 Cage LivUpDw_Pwm
P683	P693 Cage LivUpDw_PwmIn
P684	P694 Cage LivUpDw_PwmZero
P685	P695 Cage Level PWM Max
P686 Cage LivUpDw_Rmp	P696 Cage Level PWM Min
P687 Cage LivUpDw_RmpIn	P697 Cage Level PWM DeadzoneA
P688 Cage Level Start Slope Max	P698 Cage Level PWM DeadzoneB
P689 Cage Level Stop Slope Max	P699 Cage LivUpDw_PercVel

**6.5.8 Jib Leveling (Only for telescopic models)**

<b>Jib Leveling</b>	
P700 Jib LivUpDw_Jst	P710 Jib Level Stop Slope Min
P701 Jib LivUpDw_JstCa	P711
P702 Jib LivUpDw_JstTr	P712 Jib LivUpDw_Pwm
P703	P713 Jib LivUpDw_PwmIn
P704	P714 Jib LivUpDw_PwmZero
P705 Jib LivUpDw_Rmp	P715 Jib Level PWM Max
P706 Jib LivUpDw_RmpIn	P716 Jib Level PWM Min
P707 Jib Level Start Slope Max	P717 Jib Level PWM Deadzone
P708 Jib Level Stop Slope Max	P718 Jib Level PWM Deadzone
P709 Jib Level Start Slope Min	P719 Jib LivUpDw_PercVel

**6.5.9 Travel Movement**

<b>Travel Movement</b>	
P660 MachineTravel_Jst	P670 Travel Start Slope Min
P661 MachineTravel_JstCa	P671 Travel Stop Slope Min
P662 MachineTravel_JstTr	P672 MachineTravel_Pwm
P663 MachineTravel_JstRa	P673 MachineTravel_PwmIn
P664 MachineTravel_JstCa2	P674 MachineTravel_PwmZero
P665	P675 MachineTravel_PwmMax
P666 MachineTravel_Rmp	P676 MachineTravel_PwmMin
P667 MachineTravel_RmpIn	P677 MachineTravel_PwmDeadZoneA
P668 Travel Start Slope Max	P678 MachineTravel_PwmDeadZoneB
P669 Travel Stop Slope Max	P679 MachineTravel_PercVel

**6.5.10 Wheel Steering**

<b>Wheel Steering</b>	P415 Wheel Steering Speed
-----------------------	---------------------------

## **7. Parameter adjustment**

## Parameter adjustment

### 7.1 Enter password

Click the directory button on the main interface to enter the password input interface, you need to enter a four-digit password.

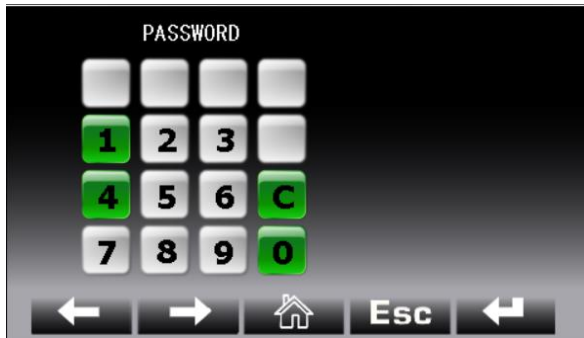

1. Press to return to the main interface;
2. Press the **Esc** button to return to the tool setting interface;
3. Press the button and the green background will cycle through from left to right;
4. Press the button and the green background will cycle through from right to left;
5. Press the button to indicate that the corresponding green background number is selected.

The password is divided into two levels. The password is "xxxx" for rental customers and "xxxx" for OEM manufacturers.



1. After the 4-digit password is confirmed, if the password is incorrect, the icon is displayed;
2. After selecting the wrong password, you need to move the cursor to the position and press the button to clear the current password.

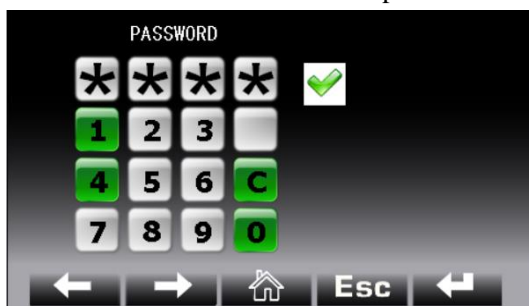

1. When the correct 4-digit password is entered, the icon is displayed;
2. After the password is entered correctly, press the button and keep it valid for 1 second to enter the function setting interface.

# Parameter adjustment

## 7.2 Function setting

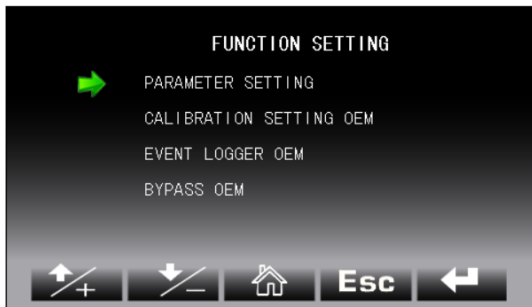

1. Press and button to switch the function list, the selected directory is indicated by green arrow ;
2. Press to return to the main interface;
3. Press the **Esc** button to return to the password input interface;
4. Press the button to enter the corresponding function setting options, such as parameters and verification setting interface.

### 7.2.1 Function parameter

1. Press and button to switch to modify the function parameter list, the selected parameter has a yellow background;
2. Press the **On/Off** button to turn on or turn off the corresponding parameter function, which means turn on, turn off;
3. Press the button **Save** to save the modified value and enter the parameter saving interface at the same time;
4. Press the **Esc** button to return to the parameter setting interface.

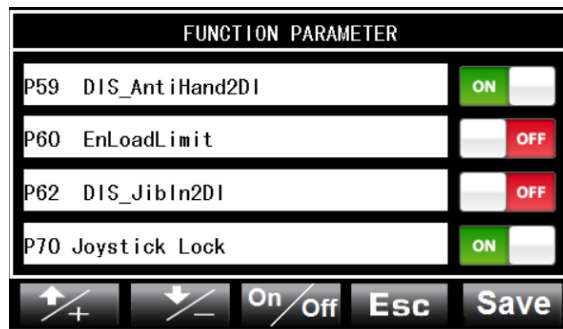

1. When the save command is 0, it means that the save was successful.

**Note:** During the save process, the system power cannot be turned off;

2. Press the button to return to the main interface;
3. Press the **Esc** button to return to the function parameter setting interface.

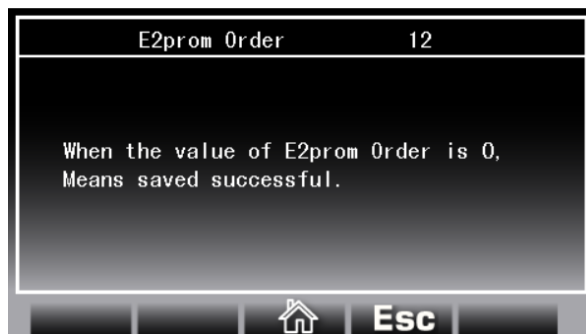

## Parameter adjustment

Function parameter list	
P0 Deadman_Model	P54 DIS_2Ch_TruckU2AMUCBO
P55 DIS_2Ch_TravelJoystick	P59 DIS_AntiHand2DI
P56 DIS_Pedal2DI	P60 EnLoadLimit
P57 DIS_LBTeleIn2DI	P62 DIS_JibIn2DI
P51 DIS_2Ch_CCR2	P70 Joystick Lock
P52 DIS_2Ch_JibU2AMUCBS	P74 DIS_LBAmpMin2DI
P53 DIS_2Ch_CageU2AMUCBS	P76 DIS_MBAmpMin2DI

### 7.2.2 Limit parameter

LIMIT PARAMETER	
P140 PaLoweBoomUp_RPM	1500
P141 PaLoweBoomDw_RPM	1500
P142 PaLoweBoomOut_RPM	1800
P143 PaLoweBoomIn_RPM	1800

1. Press and button to switch to modify the function limit parameter list, the selected parameter has a yellow background;
2. Press the button to enter the parameter setting modification interface;
3. Press the **Save** button to save the modified value and enter the parameter saving interface at the same time;
4. Press the **Esc** button to return to the parameter setting interface.

1. Indicates moving the yellow number icon to the left ;
2. Indicates moving the yellow number icon to the up;
3. Indicates moving the yellow number icon to the down;
4. Indicates moving the yellow number icon to the right;
5. Indicates that the yellow number icon is selected;



6. **Set** Change to yellow **Set**, and then press the button to send the entered number to the parameter that needs to be modified, and return to the limit parameter interface that needs to be modified;
7. **ESC** Change to yellow **ESC**, and then press the button to return to the limit parameter setting interface.

## Parameter adjustment

Limit parameter list	
P140 PaLoweBoomUp_RPM	P153 PaCageRotCCW_RPM
P141 PaLoweBoomDw_RPM	P154 PaTurretRotCW_RPM
P142 PaLoweBoomOut_RPM	P155 PaTurretRotCCW_RPM
P143 PaLoweBoomIn_RPM	P160 PaCageLivUp_RPM
P144 PaMainBoomUp_RPM	P161 PaCageLivDw_RPM
P145 PaMainBoomDw_RPM	P162 PaJibLivUp_RPM
P146 PaMainBoomOut_RPM	P163 PaJibLivDw_RPM
P147 PaMainBoomIn_RPM	P158 PaMultiMov_RPM
P148 PaJibUp_RPM	P180 PaTravelH_RPM
P149 PaJibDw_RPM	P181 PaTravelH_RPM
P150 PaJibOut_RPM	P182 PaTravelH_RPM
P151 PaJibIn_RPM	P183 PaTravelH_RPM
P152 PaCageRotCW_RPM	P184 PaTravelUTurn_RPM

### 7.2.3 Movement parameter

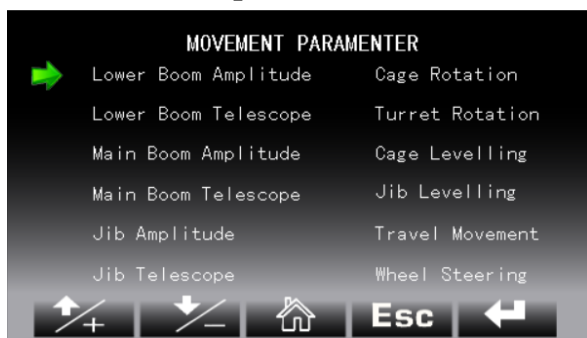

1. Press the and buttons to switch the movement parameter setting list, the selected directory is indicated by the green arrow ;
2. Press to return to the main interface;
3. Press the **Esc** button to return to the parameter setting interface;
4. Press the button to enter the corresponding parameter setting options.

Note: The parameter setting of the folding arm luffing motion and folding arm telescopic motion in the above interface is only valid for BA series models.

#### 7.2.3.1 Main boom amplitude

Main boom amplitude	
P548 Main Boom Amp Start Slope Max	P811 Main Boom Amp Rabbit Up %
P549 Main Boom Amp Stop Slope Max	P812 Main Boom Amp Rabbit Down %
P550 Main Boom Amp Start Slope Min	P813 Main Boom Amp Turtle Up %
P551 Main Boom Amp Stop Slope Min	P814 Main Boom Amp Turtle Down %

## Parameter adjustment

### 7.2.3.2 Main boom telescope

Main boom telescope	
P568 Main Boom Tele Start Slope Max	P816 Main Boom Tele Rabbit Up %
P569 Main Boom Tele Stop Slope Max	P817 Main Boom Tele Rabbit Down %
P570 Main Boom Tele Start Slope Min	P818 Main Boom Tele Turtle Up %
P571 Main Boom Tele Stop Slope Min	P819 Main Boom Tele Turtle Down %

### 7.2.3.3 Jib amplitude

Jib amplitude	
P588 Jib Amp Start Slope Max	P821 Jib Amp Rabbit Up %
P589 Jib Amp Stop Slope Max	P822 Jib Amp Rabbit Down %
P590 Jib Amp Start Slope Min	P823 Jib Amp Turtle Up %
P591 Jib Amp Stop Slope Min	P824 Jib Amp Turtle Down %

### 7.2.3.4 Jib telescope (Only for models with telescoping jib)

Jib telescope	
P608 Jib Tele Start Slope Max	P826 Jib Tele Rabbit Up %
P609 Jib Tele Stop Slope Max	P827 Jib Tele Rabbit Down %
P610 Jib Tele Start Slope Min	P828 Jib Tele Turtle Up %
P611 Jib Tele Stop Slope Min	P829 Jib Tele Turtle Down %

### 7.2.3.5 Cage rotation

Cage rotation	
P628 Cage Rotation Start Slope Max	P831 Cage Rotation Rabbit CW %
P629 Cage Rotation Stop Slope Max	P832 Cage Rotation Rabbit CCW %
P630 Cage Rotation Start Slope Min	P833 Cage Rotation Turtle CW %
P631 Cage Rotation Stop Slope Min	P834 Cage Rotation Turtle CCW %

### 7.2.3.6 Turret rotation

Turret rotation	
P648 Turret Rotation Start Slope Max	P836 Turret Rotation Rabbit CW %
P649 Turret Rotation Stop Slope Max	P837 Turret Rotation Rabbit CCW %
P650 Turret Rotation Start Slope Min	P838 Turret Rotation Turtle CW %
P651 Turret Rotation Stop Slope Min	P839 Turret Rotation Turtle CCW %

### 7.2.3.7 Cage levelling

Cage levelling	
P688 Cage Level Start Slope Max	P846 Cage Level Rabbit Up%
P689 Cage Level Stop Slope Max	P847 Cage Level Rabbit Down %
P690 Cage Level Start Slope Min	P848 Cage Level Turtle Up %
P691 Cage Level Stop Slope Min	P849 Cage Level Turtle Down %

### 7.2.3.8 Jib levelling (Only for models with telescoping jib)

Jib levelling	
P707 Jib Level Start Slope Max	P851 Jib Level Rabbit Up%
P708 Jib Level Stop Slope Max	P852 Jib Level Rabbit Down %
P709 Jib Level Start Slope Min	P853 Jib Level Turtle Up %
P710 Jib Level Stop Slope Min	P854 Jib Level Turtle Down %

## Parameter adjustment

### 7.2.3.9 Travel movement

Travel movement	
P668 Travel Start Slope Max	P863 MachineTravel HighUP %
P669 Travel Stop Slope Max	P864 MachineTravel HighDW %
P670 Travel Start Slope Min	P865 MachineTravel GoRampUP%
P671 Travel Stop Slope Min	P866 MachineTravel GoRampDW %
P861 MachineTravel ALockUP %	P867 MachineTravel LowUP %
P862 MachineTravel ALockDW %	P868 MachineTravel LowDW %

### 7.2.3.10 Wheel steering



Wheel steering	
P415 Wheel Steering Speed	

## 7.3 Sensor calibration

This menu interface is used to verify the vehicle sensors, please refer to the next chapter.

## 7.4 Data logger

Enter the detailed interface of the black box, you can view the vehicle condition information recorded simultaneously when the fault occurs, such as load, chassis angle value, main arm angle and other data.

1. Press the  and  buttons to switch the fault record list, and the selected parameter has a yellow background;
2. Press the **Delete** button and hold it for more than 3 seconds, and hear the beep sound, indicating that the black box is successfully reset; you need to press the **Esc** button and enter again to see whether the reset is successful;
3. Press the  button to enter the specific information options of the corresponding black box;
4. Press the **Esc** button to return to the fault record interface.

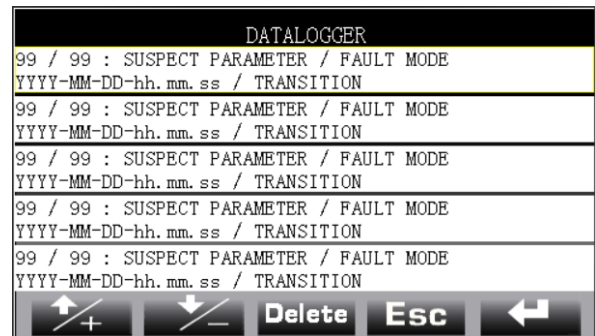



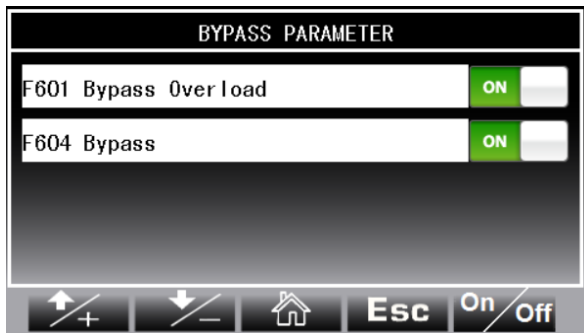

## 7.5 Bypass parameter

When the overload alarm triggers and restricts the movement of the vehicle, all movements of the vehicle are restricted. If the operator confirms that the vehicle load is within a reasonable range, the overload force function can be adopted to facilitate the movement of the vehicle or the boom;



---

## Parameter adjustment

1. Press the  and  buttons to switch and modify the parameter list, the selected parameter has a yellow background;
2. Press the  button and keep it valid for 1 second, it is used to open or close the corresponding parameter function;
3. Press the  button to return to the previous interface.

## **Sensor calibration**

# **8. Sensor calibration**

## Sensor calibration

### 8.1 Enter password

Click the directory button on the main interface to enter the password input interface, you can refer to the previous chapter. Select **校验设定-08M权限** after entering the correct password and press the **←** button to enter the sensor calibration interface.

### 8.2 Sensor calibration interface

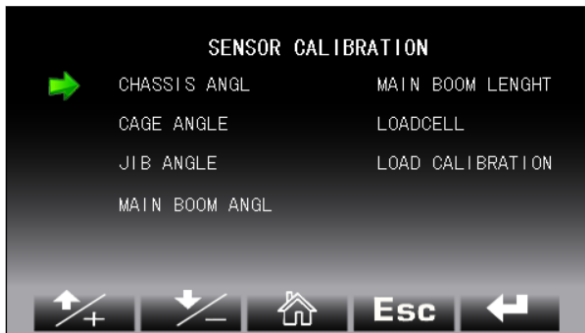

1. Press the **↑+** and **↓-** buttons to switch the verification setting list, the selected directory is indicated by a green arrow **→**;
2. Press **🏠** to return to the main interface;
3. Press the **Esc** button to return to the function setting interface
4. Press the **←** button to enter the corresponding verification setting option.

#### 8.2.1 Chassis angle sensor calibration

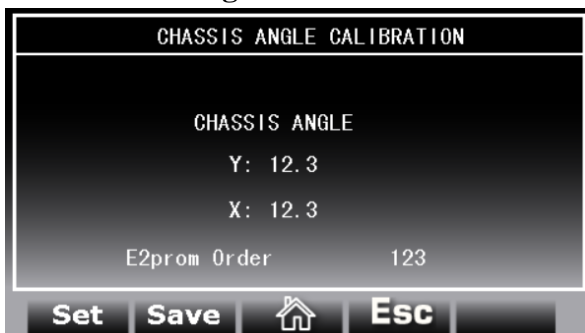

1. Press the **Set** button to reset the chassis level sensor to zero;
2. Press the **Save** button to save the modified zero-setting parameter. When the save command is 0, the save is successful.

#### 8.2.2 Platform angle sensor calibration

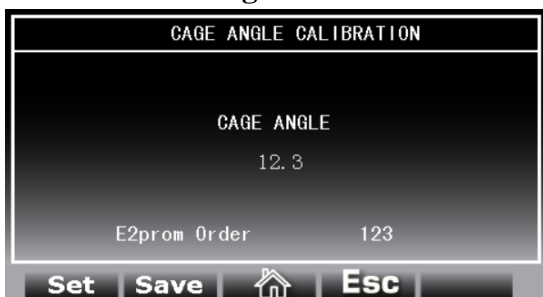

## Sensor calibration

1. Press the **Set** button to reset the platform angle sensor to zero;
2. Press the **Save** button to save the modified zero-setting parameter. When the save command is 0, the save is successful.

### 8.2.3 Jib level sensor calibration

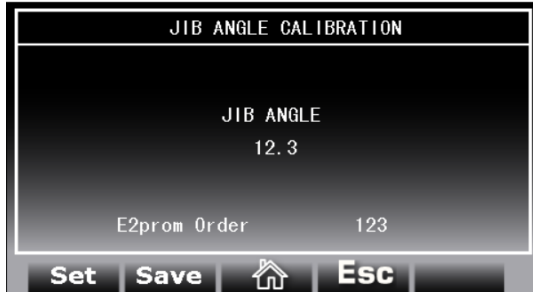

1. Press the **Set** button to reset the jib level sensor to zero;
2. Press the **Save** button to save the modified zero-setting parameter. When the save command is 0, the save is successful.

### 8.2.4 Main boom angle sensor calibration



1. Press the **Set** button to reset the main boom angle sensor to zero;
2. Press the **Save** button to save the modified zero-setting parameter. When the save command is 0, the save is successful.

### 8.2.5 Main boom length sensor calibration



1. Press the **Set** button to reset the main boom length sensor to zero;
2. Press the **Save** button to save the modified zero-setting parameter. When the save command is 0, the save is successful.

## Sensor calibration

### 8.2.6 Load sensor calibration

#### 8.2.6.1 No-load calibration of load sensor



1. Press the **Set** button to reset the load cell to zero (the platform is empty).
2. Press the **Save** button to save the modified zero-setting parameter. When the save command is 0, the save is successful.

#### 8.2.6.2 Load calibration of load sensor

LOADCELL CALIBRATION CHANNEL 1	
Adc1CellaCes1	12345
Adc2CellaCes1	12345
Noto1CellaCes1	12345
Noto2CellaCes1	12345
mCelCes1_Adc	12345
mCa_CelCes1_Kg	12345

Navigation bar: ↑ +, ↓ -, Save, Esc, ←

1. Load calibration requires independent setting of channel 1 and channel 2;
2. Load calibration requires verification of no-load and actual load;

"Channel 1 sensor analog Adc" will change in real time according to the different loads added by the platform. During calibration, the value needs to be filled in "channel 1 no-load analog Adc" and "channel 1 load analog Adc" according to the actual weight of the platform ; Channel 2 calibration method is the same as 1.

## 9. Electrical Schematic

9.1 Engine electrical schematic

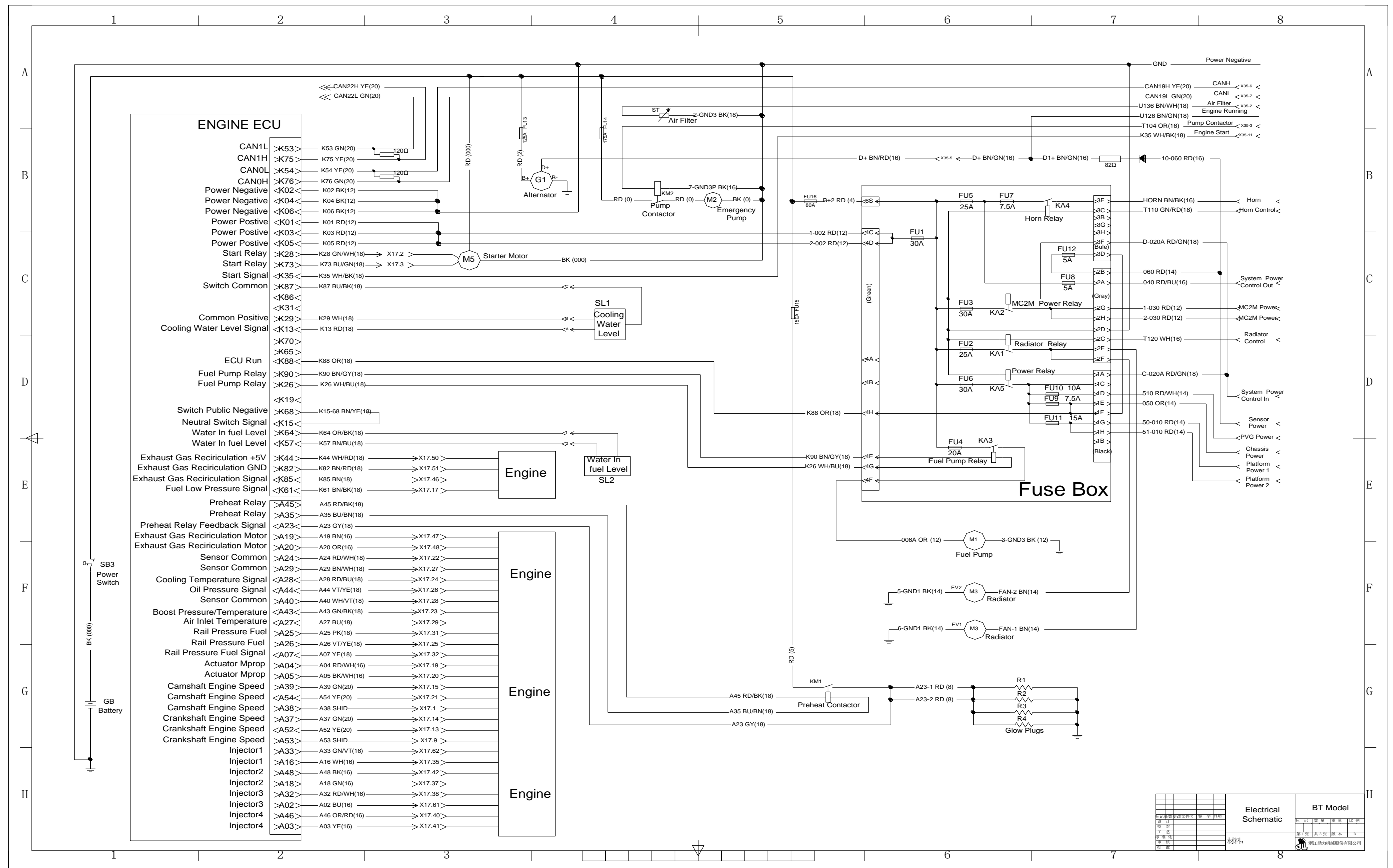

# Electrical Schematic

## 9.2 Ground control electrical schematic

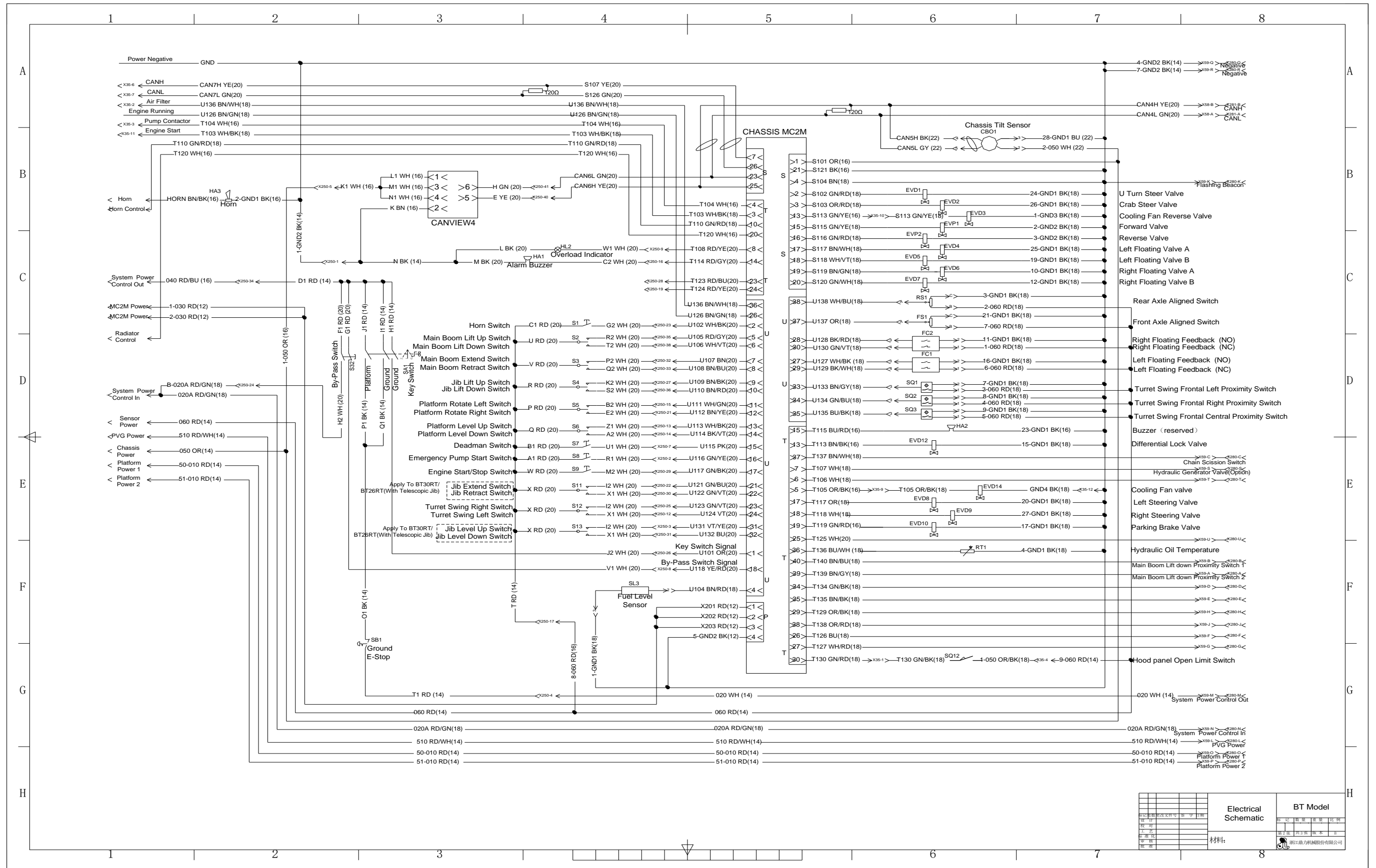

Electrical Schematic		BT Model	
图号	图例	图例	比例
设计	审核	审核	比例
工艺	审核	审核	比例
材料	浙江鼎力机械股份有限公司		

9.3 Platform control electrical schematic

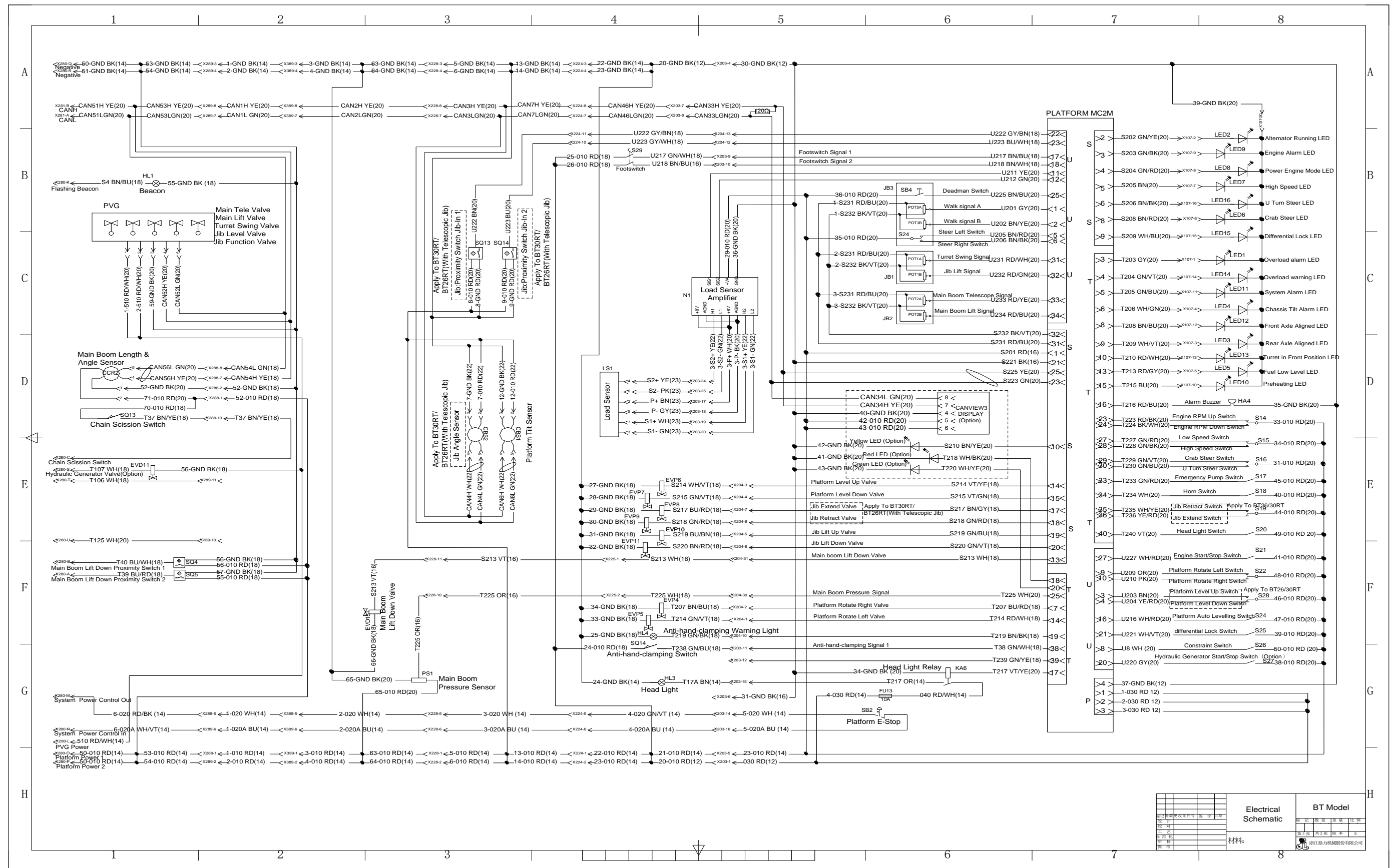

## 10. Hydraulic Schematic

10.1 BT24RT&BT26RT&BT28RT Hydraulic Schematic

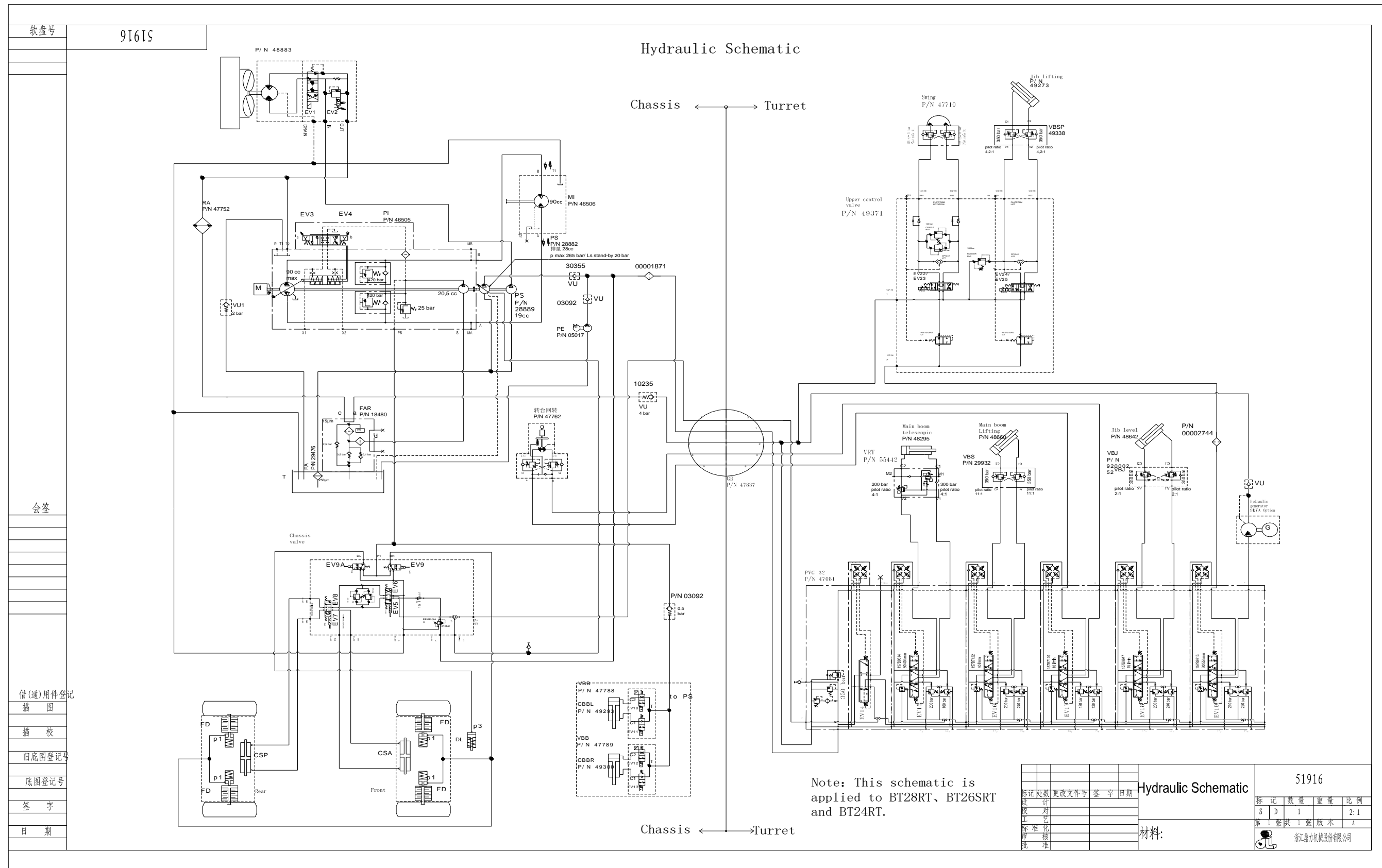

In the picture, BT26SRT is changed to BT26RT



# **11. Alarm code and solution guide**

## Alarm code and solution guide

### 11.1 Alarm codes and solutions list

When the alarm code appears, the vehicle operation will be stopped immediately. The vehicle must be operated after troubleshooting.

Alarm code	Fault category	display	Solutions	
1	MC2M hardware failure	Truck Mc2m Alalm	1.Try to restart the power supply. 2.Check the external wiring and power supply of the controller. (Measure the voltage between S1 pin and S21 pin under power-on condition should be about 12V, and measure the bus resistance between S23 pin and S25 pin under power-off condition should be about 60-120Ω) 3. Try to replace the ground controller.	
2		Truck Mc2m Alalm		
3		Truck Mc2m Alalm		
4		Truck Mc2m Alalm		
5		Basket Mc2m Alalm	1.Try to restart the power supply. 2.Check the external wiring and power supply of the platform controller. (Measure the voltage between S1 pin and S21 pin under power-on condition should be about 12V, and measure the bus resistance between S23 pin and S25 pin under power-off condition should be about 60-120Ω) 3.Try to replace the platform controller.	
6		Basket Mc2m Alalm		
7		Basket Mc2m Alalm		
8		Basket Mc2m Alalm		
9		Truck Mc2m Alalm		The solution is the same as 1, 2, 3, 4.
10		Basket Mc2m Alalm		The solution is the same as 5,6,7,8.
17	System logo	Machine Mode Not Selected	The internal controller selection parameters of the lower controller are abnormal, and check the lower control parameters. (Only for OEM permissions)	
18		Truck Tilt	It warns that the vehicle is currently tilted and dangerous movements will be restricted.	
21	Bridge valve failure	Left Axis Lock FB Error Power On	1.Check the wiring harness and connector of the left floating cylinder solenoid valve for abnormalities. 2.Try to replace the left floating valve block. 3. Try to replace the controller.	
22		Right Axis Lock FB Error Poewr On	1.Check the wiring harness and connector of the right floating cylinder solenoid valve for abnormality. 2.Try to replace the right floating valve block. 3. Try to replace the controller.	
23	System logo	Bypass On	Warn that the mandatory function of the vehicle is turned on, and dangerous actions will not be restricted.	
24		Engine Hook Open Enable	Prompt that the engine gantry switch is currently activated, under normal circumstances will limit the engine start, if the normal working engine will immediately shut down.	

**Alarm code and solution guide**

25		Transports Mode	Prompt that the vehicle is currently in the loading mode, which will limit related functions, such as automatic leveling of the platform.
26	Sensor failure	Left Axis Lock FB Error Power off	<ol style="list-style-type: none"> <li>1.Check the wiring harness and connector of the left floating cylinder solenoid valve for abnormalities.</li> <li>2.Try to replace the left floating valve block.</li> <li>3.Try to replace the controller.</li> </ol>
27		Right Axis Lock FB Error Power off	<ol style="list-style-type: none"> <li>1.Check the wiring harness and connector of the right floating cylinder solenoid valve for abnormality.</li> <li>2.Try to replace the right floating valve block.</li> <li>3. Try to replace the controller.</li> </ol>
28		Turret Proximity switch error	<ol style="list-style-type: none"> <li>1.Check the signal in the middle of the three proximity switches in the turntable. There is a logical conflict with the other two proximity switches on the side. You can check the working status of the three proximity switches on the diagnostic interface of the ground-controller-display.</li> <li>2.Check the power supply voltage of the turntable proximity switch.</li> <li>3.Check whether the three proximity switch harnesses and connectors on the turntable are abnormal.</li> <li>4.Try to replace the proximity switch with abnormal signal.</li> <li>5.Try to replace the controller.</li> </ol>
29	System logo	Bypass Input	<ol style="list-style-type: none"> <li>1.If the bypass switch of ground or platform controller is operated, the system will display this prompt.</li> <li>2.If the bypass switch of ground or platform controller is not operated, check whether the switch is short-circuited.</li> <li>3.Try to replace the ground/platform controller.</li> </ol>
30		Overload	It reminds that the weight of the vehicle platform exceeds the rated load. In this case, you need to remove the excess weight in the platform to eliminate the fault code.
31		Engine Fault	It indicates that the engine needs to be repaired at present, and the specific engine fault code needs to be checked in the engine alarm menu of the diagnosis interface. Find the corresponding fault point by referring to the fault code list of the engine.
32	System logo	PVG Fault	<ol style="list-style-type: none"> <li>1.Try to restart the power supply.</li> <li>2.Check the PVG valve block harness and connectors for abnormalities.</li> <li>3.Check whether the power supply of the PVG valve block is normal.</li> <li>4.Check if all LED lights of PVG solenoid valve are green. If there are some valves with red lights, try using a 9mm wrench to pull the valve plate.</li> <li>5. Try to replace the PVG valve block.</li> </ol>

**Alarm code and solution guide**

35		Bypass OverLoad	The overload function in the password interface is forcibly triggered, the code will appear intermittently, reminding the user that the current operation is dangerous and requires warning.
37	Engine failure	Oil water separator error	1.Try to drain the water in the oil-water separator. 2.Check whether the connection of the water level sensor in the oil-water separator is abnormal.
66	Bus timeout	Basket Mc2m Timeout	1.Check the platform controller harness for abnormalities. 2.Check whether the power supply of the platform controller is abnormal. 3.Try to replace the platform controller.
67		Engine Timeout	1.Check the engine ECU harness for abnormalities. 2.Check whether the power supply of the engine ECU is abnormal. 3.Try to replace the engine ECU.
70	Sensor failure	MB Safety Press MinValue error	1.Check the pressure sensor harness of main boom safety valve for abnormalities. 2.Check whether the pressure sensor signal output of the main boom safety valve is normal.
73	Initialization failure	AutoLevel Input Initial Error	1.If the operation is too fast, try to restart the power supply, and then operate the corresponding function when the system is in a normal working state. 2.Check whether the corresponding switch and circuit in the prompt message are short-circuited. 3.Try to replace the controller corresponding to the platform/ground.
74		AxleLock Input Initial Error	
78		Cage HydrGenerator Input Initial Error	
81	Load cell failure	LoadCell Congruence error	1.Check whether the wiring harness and connector of the load cell are abnormal. 2.Check whether the power supply of the load cell is normal. 3.Check whether the 2-way output signal of the weighing amplifier are normal, which can be checked on the diagnostic interface of the ground display. 4.Try to replace the weighing amplifier. 5.Try to replace the load cell. 6.Try to replace the platform controller.
82		LoadCell1 MinValue error	
83		LoadCell1 MaxValue error	
84		LoadCell2 MinValue error	
85		LoadCell2 MaxValue error	
86		LoadCell1 Timeout	
87		LoadCell2 Timeout	
89	Main boom telescopic handle failure	BoomZoom Joystick Congruence error	1.Check whether the harness and connector of the telescopic handle of the main boom are abnormal. 2.Check whether the power supply of the main boom telescopic handle is normal. 3.Check whether the 2-way output signal of the main boom telescopic handle are normal, which can be checked on the diagnostic interface of the ground display. 4.Try to replace the main boom telescopic handle. 5.Try to replace the platform controller.
90		BoomZoom Joystick1 MinValue error	
91		BoomZoom Joystick1 MaxValue error	
92		BoomZoom Joystick2 MinValue error	
93		BoomZoom Joystick2 MaxValue error	

**Alarm code and solution guide**

97	Main boom luffing handle failure	BoomAmp Joystick Congruence error	<ol style="list-style-type: none"> <li>1. Check whether the wiring harness and connector of the main boom luffing handle are abnormal.</li> <li>2. Check whether the power supply of the main boom luffing handle is normal.</li> <li>3. Check whether the 2-way output signal of the main boom luffing handle are normal, which can be checked on the diagnostic interface of the ground display.</li> <li>4. Try to replace the main arm luffing handle.</li> <li>5. Try to replace the platform controller.</li> </ol>
98		BoomAmp Joystick1 MinValue error	
99		BoomAmp Joystick1 MaxValue error	
100		BoomAmp Joystick2 MinValue error	
101		BoomAmp Joystick2 MaxValue error	
105	Turntable rotary handle failure	Turret Rotation Joystick Congruence error	<ol style="list-style-type: none"> <li>1. Check whether the wiring harness and connector of the rotary handle of the turntable are abnormal.</li> <li>2. Check whether the power supply of the rotary handle of the turntable is normal.</li> <li>3. Check whether the 2-way output signal of the rotary handle of the turntable is normal, which can be checked on the diagnostic interface of the ground display.</li> <li>4. Try to replace the rotary handle of the turntable.</li> <li>5. Try to replace the platform controller.</li> </ol>
106		Turret Rotation Joystick1 MinValue error	
107		Turret Rotation Joystick1 MaxValue error	
108		Turret Rotation Joystick2 MinValue error	
109		Turret Rotation Joystick2 MaxValue error	
113	Jib luffing handle failure	Jib Joystick Congruence error	<ol style="list-style-type: none"> <li>1. Check if the wiring harness and connector of the jib luffing handle are abnormal.</li> <li>2. Check whether the power supply of the jib luffing handle is normal.</li> <li>3. Check if the 2-way output signal of the jib luffing handle is normal, which can be checked on the diagnostic interface of the ground display.</li> <li>4. Try to replace the jib luffing handle.</li> <li>5. Try to replace the platform controller.</li> </ol>
114		Jib Joystick1 MinValue error	
115		Jib Joystick1 MaxValue error	
116		Jib Joystick2 MinValue error	
117		Jib Joystick2 MaxValue error	
121	Driving handle failure	Travel Joystick Congruence error	<ol style="list-style-type: none"> <li>1. Check whether the wiring harness and connector of the walking handle are abnormal.</li> <li>2. Check whether the power supply of the walking handle is normal.</li> <li>3. Check whether the 2-way output signal of the walking handle is normal, which can be checked on the diagnostic interface of the ground display.</li> <li>4. Try to replace the walking handle.</li> <li>5. Try to replace the platform controller.</li> </ol>
122		Travel Joystick1 MinValue error	
123		Travel Joystick1 MaxValue error	
124		Travel Joystick2 MinValue error	
125		Travel Joystick2 MaxValue error	
129	Initialization failure	BoomZoom Joystick AI Initial Error	<ol style="list-style-type: none"> <li>1. If the operation is too fast, try to restart the power supply, and then operate the corresponding function when the system is in a normal working state.</li> <li>2. On the diagnostic interface of the ground display screen, check the signal input value of each control handle of the vehicle in the neutral state. If the deviation is too large when not operating, the corresponding operating handle needs to be replaced.</li> </ol>
130		BoomAmp Joystick AI Initial Error	
131		Turret Rotation Joystick AI Initial Error	
132		JibAmp Joystick AI Initial Error	
133		Travel Joystick AI Initial Error	

**Alarm code and solution guide**

145	Main boom angle/length failure	Main Boom Angle Congruence error	<ol style="list-style-type: none"> <li>1. Check if the main boom angle length sensor harness connector is abnormal.</li> <li>2. Check whether the power supply of the main boom angle length sensor is normal.</li> <li>3. Check whether the 2-way output signal of the main arm angle and length sensor are normal, which can be viewed on the diagnostic interface of the ground display.</li> <li>4. Try to replace the main boom angle length sensor.</li> </ol>
146		Main Boom Angle1 MinValue error	
147		Main Boom Angle1 MaxValue error	
148		Main Boom Angle2 MinValue error	
149		Main Boom Angle2 MaxValue error	
150		Main Boom Angle 1 Timeout	
151		Main Boom Angle 2 Timeout	
152		Main Boom Angle1 system error	
153		Main Boom Length Congruence error	
154		Main Boom Length1 MinValue error	
155		Main Boom Length1 MaxValue error	
156		Main Boom Length2 MinValue error	
157		Main Boom Length2 MaxValue error	
158		Main Boom Length1 Timeout	
159	Main Boom Length2 Timeout		
160	Main Boom Length1 system error		
161	Jib level angle failure	Jib Angle Congruence error	<ol style="list-style-type: none"> <li>1. Check if the jib angle sensor harness connector is abnormal.</li> <li>2. Check if the power supply of the jib angle sensor is normal.</li> <li>3. Check whether the 2-way output signal of the jib angle sensor are normal, which can be viewed on the diagnostic interface of the ground display.</li> <li>4. Try to replace the jib angle sensor.</li> </ol>
162		Jib Angle1 MinValue error	
163		Jib Angle1 MaxValue error	
164		Jib Angle2 MinValue error	
165		Jib Angle2 MaxValue error	
166		Jib Angle1 Timeout	
167		Jib Angle2 Timeout	
168		Jib Angle1 system error	
170	Platform angle sensor failure	Cage Tilt Angle1 MinValue error	<ol style="list-style-type: none"> <li>1. Check whether the platform angle sensor harness and connector are abnormal.</li> <li>2. Check whether the power supply of the platform angle sensor is normal.</li> <li>3. Check whether the single output signal of the platform angle sensor is normal, which can be viewed on the diagnostic interface of the ground display.</li> <li>4. Try to replace the platform angle sensor.</li> </ol>
171		Cage Tilt Angle1 MaxValue error	
174		Cage Tilt Angle1 Timeout	
176		Cage Tilt Angle1 system error	
177	Chassis level sensor failure	Truck Tilt X Congruence error	<ol style="list-style-type: none"> <li>1. Check whether the chassis level sensor harness and connector are abnormal.</li> <li>2. Check whether the power supply of the chassis level sensor is normal.</li> <li>3. Check whether the 2-way output signal of the chassis level sensor are normal, which can be</li> </ol>
178		Truck Tilt X1 MinValue error	
179		Truck Tilt X1 MaxValue error	
180		Truck Tilt X2 MinValue error	

**Alarm code and solution guide**

181		Truck Tilt X2 MaxValue error	viewed on the diagnostic interface of the ground display. 4.Try to replace the chassis level sensor.
182		Truck Tilt X1 Timeout	
183		Truck Tilt X2 Timeout	
184		Truck Tilt X1 system error	
185		Truck Tilt Y Congruence error	
186		Truck Tilt Y1 MinValue error	
187		Truck TiltY1 MaxValue error	
188		Truck Tilt Y2 MinValue error	
189		Truck Tilt Y2 MaxValue error	
190		Truck Tilt Y1 Timeout	
191		Truck Tilt Y2 Timeout	
192		Truck Tilt Y1 system error	
198		Redundancy failure	
204	Jib Angle2 system error		1.Check whether the output signals of the jib angle sensor are normal, which can be checked on the diagnostic interface of the ground display. 2. Try to replace the jib angle sensor.
205	Cage Tilt Angle12 system error		The single-channel signal on the parameter interface is turned on. Just turn off this function.. (Only for OEM permissions)
206	Truck Tilt X2 system error		1.Check whether the output signals of the level sensor are normal, which can be viewed on the diagnostic interface of the ground display. 2. Try to replace the level sensor.
207	Truck Tilt Y2 system error		
211	Left Axis Lock Congruence error		1.Check whether the harness and connector of the left floating bridge switch are abnormal. 2.Check whether the 2-way output signal of the left floating bridge switch are normal, which can be viewed on the diagnostic interface of the ground display. 3.Try to clean the left floating bridge spool or replace the floating valve block. 4.Try to replace the ground controller.
212	Right Axis Lock Congruence error		1.Check whether the harness and connector of the right floating bridge switch are abnormal. 2.Check whether the 2-way output signal of the right floating bridge switch are normal, which can be viewed on the diagnostic interface of the ground display. 3.Try to clean the right floating bridge spool or replace the floating valve block. 4. Try to replace the ground controller.

**Alarm code and solution guide**

215	Initialization failure	Cage Up Input Initial Error	<p>1.If the operation is too fast, try to restart the power supply, and then operate the corresponding function when the system is in a normal working state.</p> <p>2.Check whether the corresponding switch and circuit in the prompt message are short-circuited.</p> <p>3.Try to replace the corresponding controller.</p>
216		Cage Down Input Initial Error	
217		Steering Left Input Initial Error	
218		Steering Right Input Initial Error	
219		Cage Left Input Initial Error	
220		Cage Right Input Initial Error	
221		Cage Auto levelling Input Initial Error	
222		Travel Joystick Deadman Input Initial Error	
223		Engine RPM Increase Initial Error	
224		Engine RPM Decrease Initial Error	
225		Engine Start Input Initial Error	
226		Jib Retraction Input Initial Error	
227		Jib Extention Input Initial Error	
230		Emergency Pump Input Initial Error	
232		Pedal Input Initial Error	
233		Chassis Main Boom Up Input Initial Error	
234		Chassis Main Boom Down Input Initial Error	
235		Chassis Main Boom Extention Input Initial Error	
236		Chassis Main Boom Retraction Input Initial Error	
237		Chassis Jib Up Input Initial Error	
238		Chassis Jib Down Input Initial Error	
239		Chassis Cage Left Input Initial Error	
240		Chassis Cage Right Input Initial Error	
241		Chassis Cage Up Input Initial Error	
242		Chassis Cage Down Input Initial Error	
243		Chassis Deadman Input Initial Error	
244	Chassis .Emergency Pump Input Initial Error		
245	Chassis Engine Start Input Initial Error		
246	Chassis Engine RPM Increase Initial Error		
247	Initialization failure	Chassis Engine RPM Decrease Initial Error	1.If the operation is too fast, try to restart the power

**Alarm code and solution guide**

248		Chassis Jib Retraction Input Initial Error	<p>supply, and then operate the corresponding function when the system is in a normal working state.</p> <p>2.Check whether the corresponding switch and circuit in the prompt message are short-circuited.</p> <p>3. Try to replace the corresponding controller.</p>
249		Chassis Jib Extention Input Initial Error	
250		Chassis Turret Right Input Initial Error	
251		Chassis Turret Left Input Initial Error	
252		Chassis Cage Auto levelling Input Initial Error	
253		Chassis Jib levelling Up Input Initial Error	
254		Chassis Jib levelling Down Initial Error	
257	PVG system failure	PVG0 System Error	
258		PVG1 System Error	
259		PVG2 System Error	
260		PVG3 System Error	
261		PVG4 System Error	
262		PVG5 System Error	
263		PVG6 System Error	
264		PVG7 System Error	
265	PVG output redundancy failure	PVG0 Output Congruance Error	<p>1.Check whether the PVG valve block harness and connector are abnormal.</p> <p>2.Check whether the power supply of the PVG valve block is normal.</p> <p>3.Check if all LED lights of PVG solenoid valve are green.</p> <p>4.Try to restart the power supply.</p> <p>5. Try to replace the PVG valve block.</p>
266		PVG1 Output Congruance Error	
267		PVG2 Output Congruance Error	
268		PVG3 Output Congruance Error	
269		PVG4 Output Congruance Error	
270		PVG5 Output Congruance Error	
271		PVG6 Output Congruance Error	
272		PVG7 Output Congruance Error	
273	PVG communication failure	PVG0 Timeout	
274		PVG1 Timeout	
275		PVG2 Timeout	
276		PVG3 Timeout	
277		PVG4 Timeout	
278		PVG5 Timeout	
279		PVG6 Timeout	
280	PVG7 Timeout		
281	Controller output failure	AL_TruckPinS19	<p>1.Try to restart the power supply.</p> <p>2.Check the output pin circuit and load corresponding to the fault of the controller for</p>
282		AL_TruckPinS20	
283		AL_TruckPinS17	

**Alarm code and solution guide**

284		AL_TruckPinS18	short circuits, open circuits, and impedance mismatch. 3. Try to replace the ground controller.
285		AL_TruckPinS05	
286		AL_TruckPinS06	
287		AL_TruckPinS03	
288		AL_TruckPinS04	
289		AL_TruckPinT19	
290		AL_TruckPinT20	
291		AL_TruckPinT17	
292		AL_TruckPinT18	
293		AL_TruckPinT15	
294		AL_TruckPinT16	
295		AL_TruckPinT13	
296		AL_TruckPinT14	
297		AL_TruckPinS02	
298		AL_TruckPinS13	
299		AL_TruckPinS14	
300		AL_TruckPinS15	
301		AL_TruckPinS16	
302		AL_TruckPinS08	
303		AL_TruckPinS09	
304		AL_TruckPinS10	
305		AL_TruckPinT03	
306		AL_TruckPinT04	
307		AL_TruckPinT05	
308		AL_TruckPinT06	
309		AL_TruckPinT07	
310		AL_TruckPinT08	
311		AL_TruckPinT09	
312		AL_TruckPinT10	
313		AL_TruckPinT21	
314		AL_TruckPinT01	
315		AL_TruckPinT31	
316		AL_TruckPinT11	
317		AL_TruckPinT22	
318		AL_TruckPinT02	
319		AL_TruckPinT32	
320		AL_TruckPinT12	
321	Controller output failure	AL_CagePinS19	1.Try to restart the power supply. 2.Check whether the output line corresponding to the failure of the upper controller is abnormal.
322		AL_CagePinS20	
323		AL_CagePinS17	

**Alarm code and solution guide**

324	AL_CagePinS18	3.Try to replace the platform controller.
325	AL_CagePinS05	
326	AL_CagePinS06	
327	AL_CagePinS03	
328	AL_CagePinS04	
329	AL_CagePinT19	
330	AL_CagePinT20	
331	AL_CagePinT17	
332	AL_CagePinT18	
333	AL_CagePinT15	
334	AL_CagePinT16	
335	AL_CagePinT13	
336	AL_CagePinT14	
337	AL_CagePinS02	
338	AL_CagePinS13	
339	AL_CagePinS14	
340	AL_CagePinS15	
341	AL_CagePinS16	
342	AL_CagePinS08	
343	AL_CagePinS09	
344	AL_CagePinS10	
345	AL_CagePinT03	
346	AL_CagePinT04	
347	AL_CagePinT05	
348	AL_CagePinT06	
349	AL_CagePinT07	
350	AL_CagePinT08	
351	AL_CagePinT09	
353	AL_CagePinT21	
354	AL_CagePinT01	
355	AL_CagePinT31	
356	AL_CagePinT11	
357	AL_CagePinT22	
358	AL_CagePinT02	
359	AL_CagePinT32	
360	AL_CagePinT12	
361	AL_CagePinT10	

**Alarm code and solution guide****11.2 Prompt code list and solution**

<b>Prompt code</b>	<b>English display</b>	<b>Remarks</b>
3	Main Boom Min LS	Prompt that the main arm has approached the lower limit.
4	Main Boom Max Angle Limit	Prompt that the main boom has approached the maximum angle.
5	Main Boom Min Length Limit	Prompt that the main boom is close to the minimum length.
6	Main Boom Max Length Limit	Prompt that the main boom has reached the maximum length.
7	Jib Min Angle Limit	Prompt that the current angle of jib has been tilted more than 10 degrees. In order to ensure the safety of equipment and personnel on the platform, related dangerous actions have been prohibited.
8	Cage Max Angle Limit	Prompt that the current platform has been tilted more than 10 degrees. In order to ensure the safety of equipment and personnel on the platform, related dangerous actions have been prohibited.
11	Engine High Water Temperature	Prompt that the current engine coolant temperature exceeds the preset value, you need to stop to check whether the various components of the engine cooling system are working properly, and whether there is coolant leakage.
12	Engine Low Oil Pressure	Prompt that the current engine oil pressure is lower than the preset value, you need to stop to check the engine oil level, whether there is insufficient engine oil.
13	Engine High Oil Pressure	Prompt that the current engine oil pressure is higher than the preset value, you need to stop to check the engine oil level, whether the engine lubrication system is blocked.
14	Engine Air Filter	Prompt that the engine air filter is clogged, and the air filter needs to be repaired. At the same time, the air cleaner sensor and its circuit also need to be repaired.
15	Engine Hood Open	Prompt that the current engine protection cover is open, prohibit starting the engine.
16	Engine Low Fuel Level	Prompt that the current fuel level of the engine is too low and fuel needs to be added in time.
17	Hydraulic High Temperature	Prompt that the temperature of the hydraulic oil of the vehicle is too high, and it is necessary to check whether the cooling system of the hydraulic oil is faulty in time.
20	System Fault	Prompt that the electric control system is faulty, try to restart the power supply.
21	Truck Tilt Limit	Prompt that the current vehicle chassis has exceeded the set angle.
22	Double Movement Limit	Prompt that the current compound action function of the vehicle is turned off and compound action is prohibited.
23	Cage Out of Level Up Limit	Prompt that the current platform is in a tilted state, and it is forbidden to operate the main boom to lift.
24	Cage Out of Level Down Limit	Prompt that the current platform is in a tilted state, and it is forbidden to operate the main boom to lift.
25	Overload Prewarning	Prompt that the vehicle platform load is close to the overload setting value.
26	Overload Limit	Prompt that the load of the vehicle platform has reached the overload setting value, and the function operation is prohibited.

**Alarm code and solution guide**

33	Jib In	Prompt that the current telescopic jib is fully retracted.
34	Axis Fault	Prompt the failure of the bridge lock valve, check the working status of the bridge lock function.
35	Watch Dog Sleep	Prompt that the controller is in sleep low power consumption state, try to restart the power to wake up.
41	Turret Joystick KO	Prompt that the rotary handle of the vehicle turntable is faulty and needs to be repaired.
42	LoadCell KO	Prompt that the vehicle load cell (or load cell amplifier) is faulty and needs to be repaired.
44	Main Boom Joystick KO	Prompt that the vehicle's main boom handle is faulty and needs to be repaired.
45	Jib Joystick KO	Prompt the vehicle jib handle failure, need to be repaired.
46	Travel Joystick KO	Prompt that the vehicle's walking handle is faulty and needs to be repaired.
51	Chain loose Fault	Check the status of the telescopic boom chain. If the chain tension is normal and the broken chain detection switch is not triggered, you need to check whether the switch harness and the switch itself are damaged.
54	Overload LMI	For BT30RT models, it is indicated that the current load of the platform has exceeded 300kg, and the vehicle cannot be operated at full travel at this time.
55	BoomMove Stop Travel	When the action interlock function is turned on, the prompt will appear when the walking and boom actions are operated at the same time.
56	Travel Stop BoomMove	When the action interlock function is turned on, the prompt will appear when the walking and boom actions are operated at the same time.
58	LMI Pre_Warning	Prompt that the state of the vehicle at this time is close to the range limit area and will soon give an alarm.
60	Emergency Pump Work	Prompt that the current emergency pump is in working state, it is forbidden to operate the main boom lifting and main boom extension.
61	Joystick Lock	Prompt that the current vehicle handle interlocking function is enabled, prohibiting the handle to operate two or more actions at the same time.
64	LMI Block	Prompt that the current vehicle state has reached the maximum working range, and it is forbidden to continue to operate dangerous actions.
72	Anti Extrusion Switch On	The anti-squeeze switch is triggered during work, and can be reset by re-operating the foot switch.
73	Transports Mode No Amplitude	Prompt that in the loading mode, it is forbidden to operate the main arm with a variation greater than 20 degrees.
74	Hydraulic Generator On	Prompt that the current hydraulic generator is in working state, prohibit other actions.
75	Transports Mode No Telescope	Prompt that the vehicle is currently in the loading mode, it is forbidden to operate the main boom to extend.
76	Pedal Switch Congruence Limit	In the diagnostic interface of the ground display, check whether the two input signals are staggered when the foot switch is working. If necessary, replace the foot switch.
80	Length Sensor Error	First try to restart the power supply, and then check whether the wire rope of the main boom length sensor is broken. If necessary, replace the length sensor.
84	Battery Work Too Long	Remind the operator that the battery is in a state of depletion, please turn off the power in time.
89	Main Boom Safety Press High	If the main boom of the vehicle is in a static lift state for a long time, and the prompt appears after the power is turned on, you only need to operate the main boom to raise or lower to clear the prompt.

## Alarm code and solution guide

110	Tilt Turret Not Center	Prompt that the current turntable is tilted and the turntable of the vehicle is not in the center position. At this time, turn the turntable or drive the vehicle to a horizontal position.
111	Tilt Main Boom Up	Prompt that the current turntable is in a tilted state, it is forbidden to operate the main boom luffing function.
112	Tilt Main Boom Out	Prompt that the current turntable is in a tilted state, and it is forbidden to operate the main boom extension function.
113	Tilt Main Jib Out	Prompt that the current turntable is in a tilted state, and it is forbidden to operate the jib extension function.

## 11.3 Solutions to common problems

### 11.3.1 The upper part of the platform frame hits an obstacle and causes the machine to appear overload alarm

Solutions:

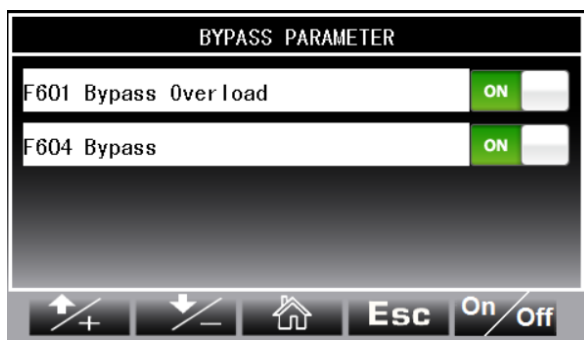

Solution 1: Enter the password on the ground display to enter the mandatory interface, select F601 Bypass Overload function (valid for three minutes), and turn on the right switch. You can temporarily operate the relevant actions to lift the boom out of obstacles. After the operation is completed, turn off the function or restart the system power.

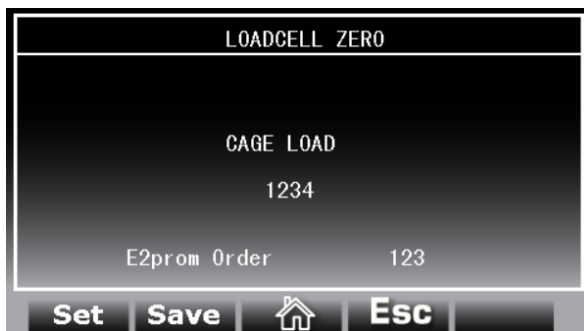

Solution 2: Enter the password on the ground display to enter the sensor calibration interface, and select the load cell to clear. Click Enter and press the Set button. After the platform load weight is displayed as 0, you can temporarily operate the relevant actions to remove the arm from the obstacle. After the operation is complete, restart the system power.

**Note: Do not operate the Save command after the reset is completed.**

**11.3.2 The bottom of the platform frame hits the ground or other obstacles causing the machine to have a load cell 2 open circuit error**

Solution:

Press and hold the bypass switch of the ground control panel while lifting the jib during normal operation to temporarily lift the platform frame off the ground or obstacles.

**11.3.3 Redundancy failure of length and angle sensor in ground display**

Solutions:

Solution 1: Try to use computer debugging to re-calibrate the signal of the 2-way length sensor.

Solution 2: Locate the vehicle length and angle sensor, remove the end of the sensor wire rope and pull it out about 5cm, then fix the end again.

Enter the password on the ground display to enter the sensor calibration interface and select the length of the main boom. After the main boom is fully retracted, click to enter and press the Set button. At this time, the length of the main boom of the display screen will change. Press the Save button, wait until the number after the save command becomes 0, and then restart the system.

**11.3.4 The vehicle cannot start the engine.**

Solutions:

Solution 1: Before the machine is powered on and not operated, the electronic diesel pump is in working state and will automatically stop after a few seconds. If the electronic diesel pump does not work after power-on, you need to check whether the fuse of FU4 20A electronic diesel pump in the fuse box has blown. If the fuse is blown, do not replace the fuse immediately. First of all, the influence of diesel pipelines should be ruled out. For example, the unreasonable use of diesel in winter (the use of 0# diesel in a -10°C environment causes diesel wax to block the diesel pipeline), and the use of low-quality irregular diesel can also cause filter plugging.

Solution 2: Whether the electrical system will restart when the engine starts, check whether the 12V battery of the vehicle is feeding. When necessary, an external auxiliary start is required.

## **12. Maintenance**

## Maintenance



### 12.1 Observe and Obey:

- ☑ The operator must only carry out the routine maintenance specified in this Manual.
- ☑ The scheduled maintenance activities must be performed by the workers trained and qualified by manufacture and according to the requirements listed in the Maintenance Manual of this machine.
- ☑ Dispose of the materials in compliance with the national regulatory standards in force.
- ☑ Only use spare parts authorised by DingLi.

### 12.2 Preliminary checks:

Every time the machine is used by a new owner, make sure the correct Use and Maintenance Manual corresponding to the machine is present on board.

If this is not the case, immediately contact the dealer for the correct Manual.

Check to make sure the plates and stickers are present on the machine and are in good condition.

If they are damaged or illegible, ask your dealer for a replacement copy.

### 12.3 MAINTENANCE SCHEDULE

Read and understand all the warnings and instructions before starting any maintenance operation.

Before carrying out any maintenance operation, make sure all the scheduled actions have been carried out as planned.

#### A Every 10 hours of operation or daily

- A-1 Visual inspection - checking
- A-2 Engine oil level - check
- A-3 Coolant level - check
- A-4 Telescopic boom sliding blocks - check
- A-5 Auxiliary pump - operating test
- A-6 Overload sensor - check

#### B Every 50 hours of operation or every 2 weeks

- B-1 Transmission shaft - lubrication of universal joints
- B-2 Axles - lubrication of oscillation bushes
- B-3 Hydraulic oil level - check
- B-4 Telescopic boom sliding blocks - lubrication
- B-5 Fuel pre-filter - draining the water
- B-6 Turret rotation slewing ring gear -lubrication
- B-7 Wheels - check tightening of nuts
- B-8 Radiator - cleaning by rotating reversely

#### C Every 250 hours of operation or every 3 months

- C-1 Transmission belt - check
- C-2 Differentials oil - check
- C-3 Wheel reduction gears oil - check
- C-4 Steering elements - lubrication
- C-5 Turret rotation slewing ring gear - check reduction gear oil level

#### D Every 500 hours of operation or every 6 months

- D-1 Hydraulic oil filter - replacement
- D-2 Engine oil and filter - replacement
- D-3 Fuel pre-filter - replacement
- D-4 Engine radiator - cleaning
- D-5 Turret rotation slewing ring gear - check tightening of bolts

#### E Every 1000 hours of operation or every year

- E-1 Fuel filter - replacement
- E-2 Air filter - replacement of primary cartridge
- E-3 Differentials oil - change
- E-4 Wheel reduction gears oil - change
- E-5 Telescopic boom sliding blocks – adjust the play
- E-6 Turret rotation slewing ring gear -change reduction gear oil - check play
- E-7 Overload sensor - calibration

#### F Every 1500 hours of operation

- F-1 Fuel filter - clean mesh element

#### G Every 2000 hours of operation or every 2 years

- G-1 Hydraulic fluid - change
- G-2 Air filter - replacing the safety cartridge

## Maintenance

### 12.3.1 Checklist A Procedures

#### A-1 Visual inspection

To ensure the maximum useful operating life of the vehicle, proceed with a thorough visual inspection before every starting up.

Look around and under the vehicle, checking to make sure there are no slack or missing bolts, no accumulated dirt, leakage of oil, fuel and other liquids, broken or worn parts.

Check the state of the accessories and hydraulic components.

Check the state and wear of the tyres. If necessary

Check the oil, coolant and fluid levels. Check the AdBlue® tank level (if present).

Remove all accumulated dirt and debris. Carry out all the repairs necessary before starting up the vehicle.

#### A-2 Engine oil level-check



#### ATTENTION

**Do not operate with the engine running!**  
**Do not smoke or use naked flames!**  
**Danger of burns!**

During operations on the lubricant oil system, ensure utmost cleanliness. Thoroughly clean the area around the components concerned from time to time.

Dry the damp parts with air jets. For handling lubricant oils follow the safety directives and specific local standards.

Dispose of the leaked lubricant oil and the filter elements. Do not let the used lubricant oil spread in the ground. Run a test cycle after every intervention. At the same time, ensure sealing and pressure of the lubricant oil and then check its level.

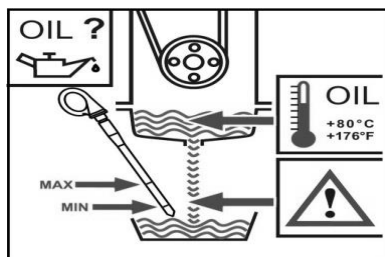

An insufficient and/or excessive lubricant oil level can damage the engine. Check the oil level only with the engine horizontal and stopped. Check the lubricant oil level only while it is warm, 5 minutes after the engine is switched off. Do not remove the oil level rod with the engine running. Danger of burns.

Remove the rod and wipe it clean with a cloth, do not leave fibres. Insert the oil rod up to the stop then remove it and read the lubricant oil level.

The level must be between the MIN and MAX level! Top up to the MAX notch if necessary.

#### A-3 Coolant level-check



#### DANGER OF BURNS

**The coolant is pressurised and at high temperature with the engine switched on. When the cap is removed, the liquid may flow out violently and cause serious burns. Make sure the engine is cold before working on the cooling system.**

#### Checking

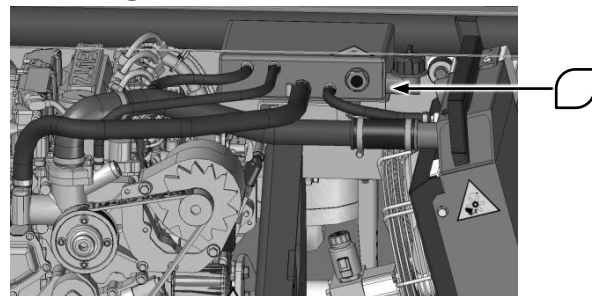

Set the vehicle in the parking position.

Check the level in the expansion tank placed above the radiator. The level is correct when it is half-way on the inspection window.

Open the tank, check the coolant additive concentration ratio using the instrument concerned (e.g. hydrometer, refractometer)

If necessary, top up with a suitable mixture depending on the use.

Refit the cap and make sure it is tightened properly. Run the engine to bring it to the required temperature. Switch off the engine and check for leaks in the circuit.

## Maintenance

### A-4 Telescopic boom sliding blocks - check

Extend the telescopic boom completely.

Check to make sure the boom movement is smooth. Ensure that there are no abnormal vibrations, unusual noises, and no part of the boom gets heated due to friction during the movement.

Remove the dust guard gaskets at the head of the extensions and check to ensure there is a sufficient layer of grease on the sliding surfaces and on the sliding blocks.

### A-5 Auxiliary pump test

Press the red emergency button: reset it to stop the I.C. engine.

Activate the emergency pump and test the movements of the booms and platform.

**NOTE:** to avoid consuming the batteries, limit the test duration time.

To confirm the correct working, deactivate the emergency electric pump and restart the I.C. engine.

### A-6 Overload Sensor - checking

How much the load weighted by the overload sensor is in the platform will be indicated on the panel on the ground control console. If the load in the platform does not exceed rated load, the vehicle is safe during work. Otherwise, it is dangerous and the alarm will be activated. So, it is important to make sure the sensor is in good condition before starting work every day.

#### Bolt -checking

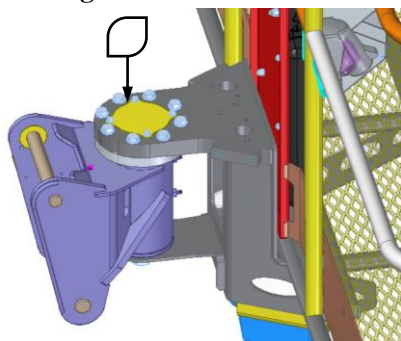

Check if there is some bolts is slacken or missing and the sensor undamaged. If there is abnormal condition, ask for help from DingLi or your agency.

### Overload Sensor - checking

It is critically important for safety of life and property of operators to make sure the sensor works well. Checking and Making sure the sensor is in good condition before starting work every day could protect operators from danger. When there is some collision on platform, stop working and to check if the sensor is well. The procedures as follows:

Vehicle Condition Interface indicating data on vehicle condition can be entered by depressing down the Data button on the ground control contation.

MAIN BOOM ANGLE	12.3 °
MAIN BOOM LENGHT	0.123 m
JIB ANGLE	12.3 °
CAGE ANGLE	12.3 °
CHASSIS TILT ANGLE X	12.3 °
CHASSIS TILT ANGLE Y	12.3 °
HYDRAULIC TEMPERATUR	60 °C
CAGE LOAD	120 Kg
BT30 LOADCHART	450 Kg

Engine   Data   Set   ESC   Menu

Cage load parameter shows the current load in the platform.

Cage load parameter will show 0kg when the load in the platform is removed completely.

Cage load parameter will show 454kg at the moment of 454kg being added in the platform.

Continue to add load in platform, and then the alarm will be activated when the load is up to 525kg. Otherwise, stop to ask for repairing.

The accuracy of weighting is  $\pm 10\%$ . If the data exceeds it, stop to calibrate it, referring to the chapter E-7.

## Maintenance

### 12.3.2 Checklist B Procedures

#### B-1 Transmission shaft - lubrication of universal joints

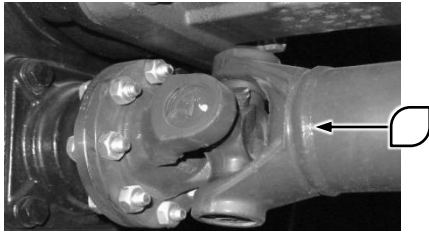

Set the vehicle in the parking position. Make sure no one approaches the work area.

Lubricate the universal joints by injecting grease into the grease nipples. Repeat for all the transmission shaft joints. Remove the excess grease.

#### B-2 Axles-lubrication of oscillation bushes

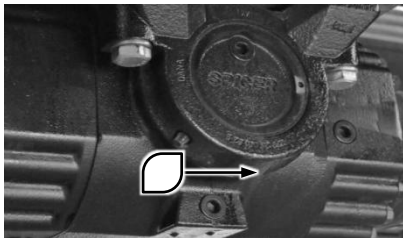

Set the vehicle in the parking position. Make sure no one approaches the work area.

Stand near the front axle oscillation bushes. Inject grease in the grease nipples present on both sides of the axle (front and rear).

Repeat the lubrication for the rear axle.

#### B-3 Hydraulic oil level-check

For correct working of the machine, check to make sure the level of oil in the hydraulic system is sufficient. Incorrect level of oil in the hydraulic system can damage the components. Daily inspections will make it possible to detect changes in the oil level which could indicate the presence of faults in the hydraulic system.

Make sure the boom is in the retracted position.

Check the oil level indicator on the side of the hydraulic tank.

Result: the oil level in the hydraulic system must be near the centre line of the level indicator present on the tanks.

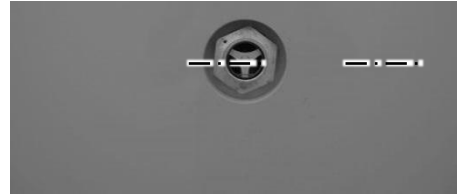

Add oil if necessary. Do not exceed the level indicated.

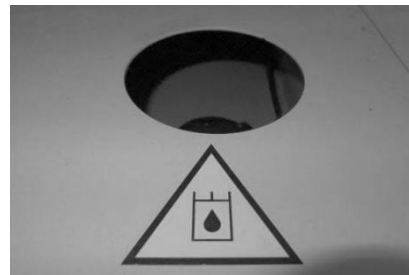

**Note:** The hydraulic oil should be applied to the local environment, and be filtered at the accuracy of 20µm.

#### B-4 Telescopic booms sliding blocks - Lubrication

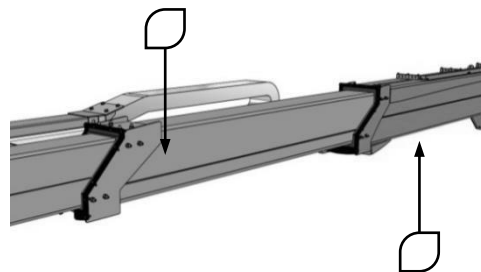

Position the machine in an area with sufficient clearance around it; centre the turret and bring the telescopic boom to the horizontal position. Extend the telescopic boom completely.

Remove the dust guard gaskets at the head of the extension and clean all the sliding surfaces thoroughly.

Using a brush, apply a thin layer of grease on the sliding surfaces on all four sides of the boom. Repeat the operation for each stage of the extension.

## Maintenance

Retract and extend the telescopic boom a number of times to distribute the grease uniformly.

Remove excess grease to prevent dirt build-up and refit the dust guard gaskets.

### B-5 Fuel pre-filter – draining the water



#### FLAMMABLE MATERIAL

Fuel is flammable and can cause severe burns and death.

Do not smoke or use naked flames while working on the fuel line.

Clean the engine parts and engine compartment to remove all traces of fuel to prevent risk of fire.

### Deutz pre-filter-draining water

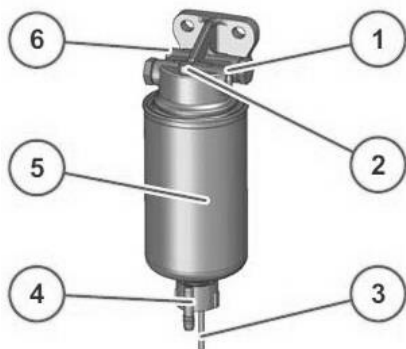

- (1) Pump fuel supply
- (2) Bleed screw
- (3) Electric connection for the water level sensor
- (4) Drainage cap
- (5) Filter cartridge
- (6) Fuel tank inlet

Stop the engine.

Place a suitable container.

Disconnect the cables.

Slacken the drainage screw.

Drain the liquid until the pure diesel fuel starts flowing out.

Fit the drainage cap by applying a tightening torque of  $1.6 \pm 0.3$  Nm.

Reconnect the cables.

### Parker pre-filter-draining water

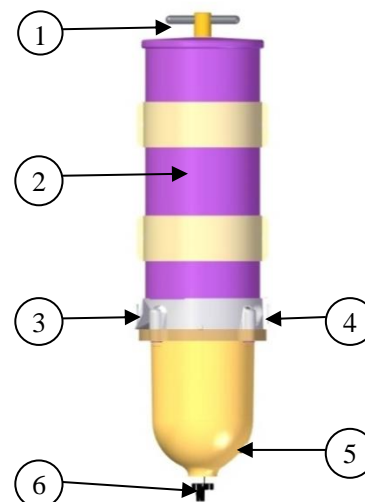

- (1) Joystick
- (2) Filter cartridge
- (3) Pump fuel supply
- (4) Fuel tank inlet
- (5) Plug
- (6) Drainage cap

Stop the engine.

Place a suitable container.

Slacken the drainage screw.

Drain the liquid until the pure diesel fuel starts flowing out.

Fit the drainage cap by applying a tightening torque of  $3.5 \sim 4$  Nm.

### B-6 Turret rotation slewing ring gear - Lubrication

Lubricate both the turret axial bearing tracks by means of the two grease nipples provided inside. Lift the primary telescopic boom for access into the slewing ring gear, inject a number of shots of grease and move the turret to distribute the grease uniformly.

Lubricate the outer teeth of the slewing ring gear. Apply grease manually using a brush. Ensure that the grease is distributed uniformly. Remove grease buildup.

**Anyone in the follow table should be chosen when the vehicle is used in the normal environment.**

## Maintenance

### Grease for standard application

GREASE BRAND	FOR RACEWAY	FOR GEAR TEETH
Shell	GADUS S2 v220 2 EP2	MALLEUS OGH
Mobil	MOBILUX EP2	MOBILTAC 81
Castrol	SPHEEROL EPL2	MOLLUB-ALLOY 970/2500-1
TOTAL	MULTIS EP2	CERAN AD PLUS
FUCHS	LAGERMEISTE R EP2	CEPLATTYN KG 10 HMF

If the machine is used in the severe environment, refer to DingLi for the grease.

### B-7 Wheels - check tightening of nuts

It is extremely important to apply and maintain proper mounting torque.

**Tighten the lug nuts to the proper torque to prevent coming loose.**

Wheel nuts should be torque after first 50 hours of operation and after each wheel removal. Use a torque wrench to tighten fasteners. If you do not have a torque wrench, tighten the fasteners with a lug wrench, then immediately have a service garage tighten the lug nuts to the proper torque. Over-tightening result in breaking the studs or permanently deforming mounting stud holes in the wheels. The proper procedure attaching wheels is as follows:

Set the torque wrench to 450Nm.

Tighten nuts in the following sequence:

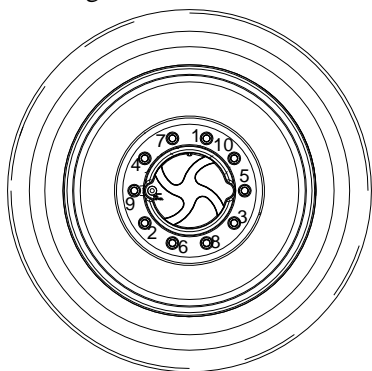

When there is sound like ‘kada’, the lug nut is fastened at proper torque.

### B-8 Radiator-cleaning by rotating reversely

The radiator should be cleaned termly for cooling effectively. There is a method for cleaning the radiator easily.



### Cooling fan reverse

The setting interface could be entered by depressing setting button and hold on for one second. Cooling fan reverse can be activated as follows:

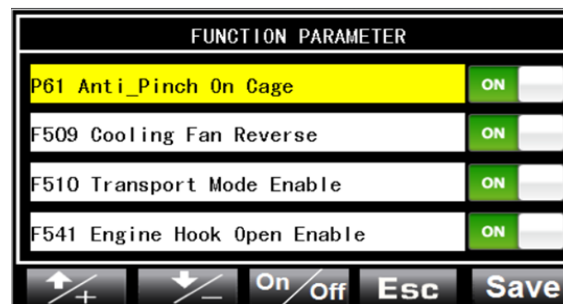

Depressing or is used to change the item. Chose F509. The chosen item would be shown in yellow background.

Depressing and holding on for one second is used to turn on or off corresponding function.

Save the modified value by depressing the button .

Modifying “F509 cooling fan reverse”, is only valid in condition of power on. It will return back at the moment of interruption of power supply.

It returns back to main interface, when the button is depressed.

After continuing for 5 minutes, recover the above settings.

## Maintenance

### 12.3.3 Checklist C Procedures

#### C-1 Transmission belt



#### ATTENTION

Work on the transmission belt only with the engine stopped! After repairs, make sure all the protection devices have been refitted and that no tool has been forgotten on the engine.

#### Checking the belt tension

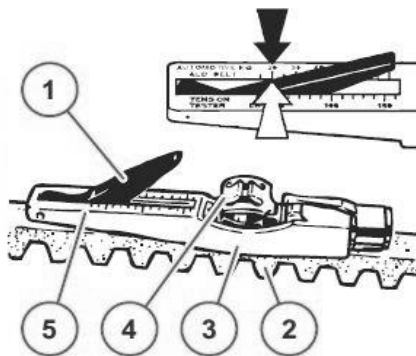

To check the tension of the belts, lower the arm of indicator (1) in the tester.

Place the guide (3) between two pulleys on the V-belt (2). At this point, the stop must be on the side.

Press button (4) in the RH corner with respect to V-belt (2) uniformly until the spring clicks audibly.

Lift the tester gently, without modifying the position of the indicator arm (1).

Read the value measured on the intersection point (arrow), scale (5) and indicator arm (1). Correct the tension if necessary and repeat the measurement.

The belt tension tester can be ordered through the Customer Service.

#### Replacement (when required)

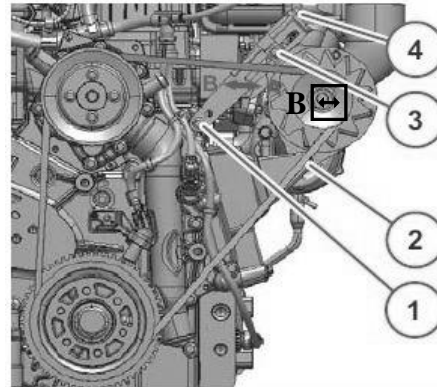

- (1) Screw
- (2) Screw
- (3) Screw
- (4) Adjuster wrench

To replace the transmission belt:

Slacken the screw and lock nut,

Move the generator above the adjuster wrench in direction (B) until the belt slackens,

Remove the belts and fit the new ones,

Reposition the generator above the adjuster wrench in direction (A) until the belt tension is correct,

Check the belt tension:

pre-tensioning  $650 \pm 50$  Nm

correct tension  $400 \pm 50$  Nm

Tighten the screw and lock nut.

Tightening torque: screw (1) 30 Nm

screw (2) 42 Nm

screw (3) 30 Nm

## Maintenance

### C-2 Differentials oil - Check

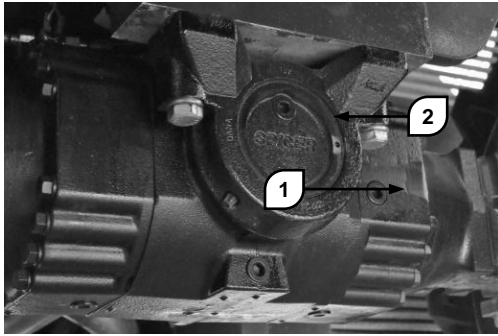

Set the vehicle in the parking position. Make sure no one approaches the work area.

Remove level cap 1. The oil must flow out through the opening.

If necessary, remove filler cap 2. Add oil to the correct level. Close level cap 1, and then filler cap 2. Clean the axle surfaces.

Repeat the operations for the front and rear differential.

### C-3 Wheel reduction gears oil -Check

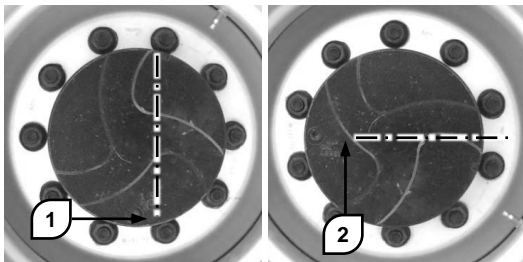

Set the vehicle in the parking position. Turn the reduction gear cap in the horizontal position 2.

Remove the cap. The oil level is correct when the oil flows out through the filler hole. If necessary, top up with oil (photo) 2 to the correct level.

Refit the cap.

Repeat this operation for each wheel.

### C-4 Steering elements -Lubrication

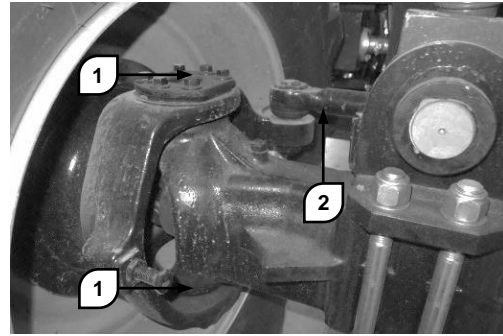

Lubricate the wheels rotation pins 1 by injecting grease in the grease nipples provided for the purpose. Remove the excess grease.

Lubricate the ball joint 2 injecting grease in the grease nipples provided for the purpose. Remove the excess grease.

### C-5 Turret rotation slewing ring gear - check reduction gear oil level

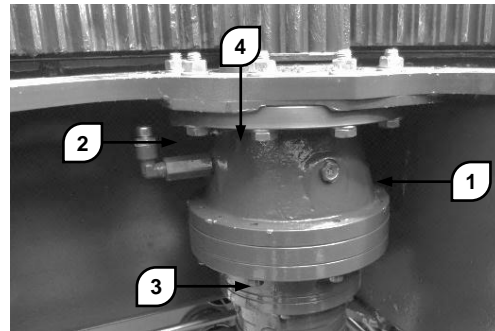

Retract and lift the telescopic boom completely. Rotate the turret for better access to the reduction gear.

Check the hydraulic fluid level through the inspection window 1. The level is correct when it overflows.

If necessary, top up with oil of the right strength up to the filler hole 2.

When checking the oil level, also check the bolts fixing the reduction gear to the chassis. In case of faults (rusted, slackened or missing bolts), contact your dealer.

## Maintenance

### 12.3.4 Checklist D Procedures

#### D-1 Hydraulic oil filter - replacement

The machines use three filters for hydraulic fluid: the filter placed on the inside of the hydraulic tank has the combined function for oil at the suction as well as return. The others are PLFA series filters used in the pressure line of hydraulic system. One is placed on the back side of the hydraulic tank, and the other is placed on the end of the third boom.

##### Suction filter

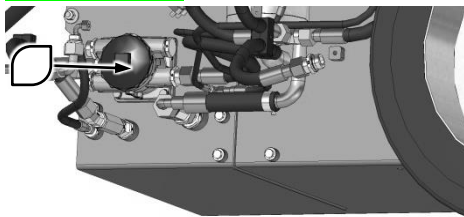

Stabilise the machine to facilitate accessibility to the filter in question: clean the filter housing and surrounding areas to prevent dirt from entering the circuit. Unscrew the cap.

Replacing the filter cartridge does not involve draining the tank: the filter cartridge is provided with a special plant closure system. When it is being removed, the oil present inside the filter normally flows out

Remove the filter cartridge and dispose of according to the regulatory standards in force. Insert a new filter cartridge of the same type. Refit the filter cover. Start up the engine and check for leaks.

Check for a drop in the oil level through the window present on the tank: if required, top up with the quantity necessary to reach the correct level.

##### PLFA filter (outlet of pump)

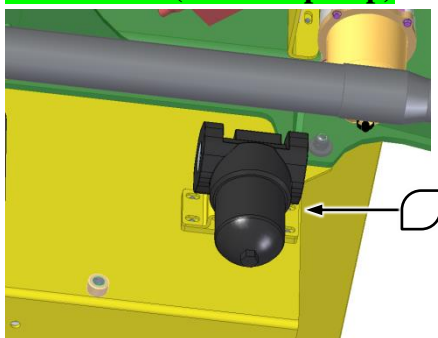

Clean the area around the oil filter, and then remove the cap components.

Pull out the filter element from the filter assembly chamber.

Install the new filter element to the filter assembly chamber.

Refit the cap components and tighten it. Clean up any oil that may have spilled during the replacement procedure.

##### PLFA filter (Inlet of upper control valve)

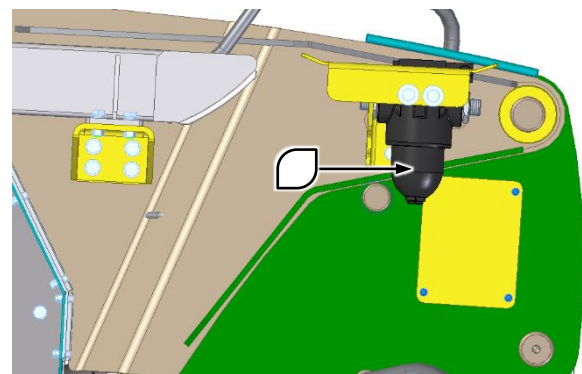

Clean the area around the oil filter, and then remove the cap components.

Pull out the filter element from the filter assembly chamber.

Install the new filter element to the filter assembly chamber.

Refit the cap components and tighten it. Clean up any oil that may have spilled during the replacement procedure.

## Maintenance

### D-2 Engine oil and filter -replacement



**ATTENTION**

**Do not operate with the engine running!**

**Do not smoke or use naked flames!**

**Danger of burns!**

During operations on the lubricant oil system, ensure utmost cleanliness. Thoroughly clean the area around the components concerned from time to time.

Dry the damp parts with air jets. For handling lubricant oils follow the safety directives and specific local standards.

Dispose of the leaked lubricant oil and the filter elements. Do not let the used lubricant oil spread in the ground. Run a test cycle after every intervention. At the same time, ensure sealing and pressure of the lubricant oil and then check its level.

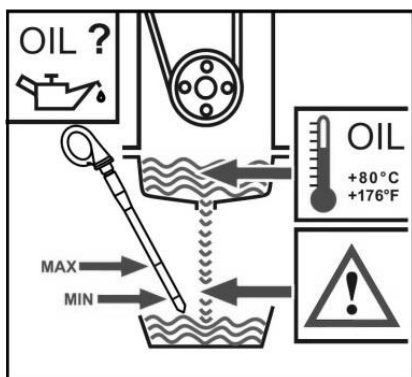

An insufficient and/or excessive lubricant oil level can damage the engine. Check the oil level only with the engine horizontal and stopped. Check the lubricant oil level only while it is warm, 5 minutes after the engine is switched off. Do not remove the oil level rod with the engine running. Danger of burns.

### Changing the engine oil

Heat the engine until the oil temperature reaches  $> 80^{\circ}\text{C}$ .

Park the vehicle on a horizontal surface and stop the engine.

Place a container under the drain screw, unscrew the latter and drain out the lubricant oil.

After draining, reposition the screw with a new sealing ring and tighten by applying a 55 Nm torque.

Fill lubricant oil, warm the engine to a temperature  $> 80^{\circ}\text{C}$  and check the lubricant oil level.

Top up, if necessary.

### Replacing the lubrication oil cartridge



Slacken the filter using the tool and unscrew it.

Collect the lubricant oil that flows out.

Wipe the surface of the filter-holder with a clean cloth that does not leave lint.

Oil the original DEUTZ filter cartridge seal slightly.

Screw the manual filter by hand until it is tight.

## Maintenance

### D-3 Fuel pre-filter - replacement



#### FLAMMABLE MATERIAL

Fuel is flammable and can cause severe burns and death.

Do not smoke or use naked flames while working on the fuel line.

Clean the engine parts and engine compartment to remove all traces of fuel to prevent risk of fire.

#### Deutz Fuel pre-filter replacement

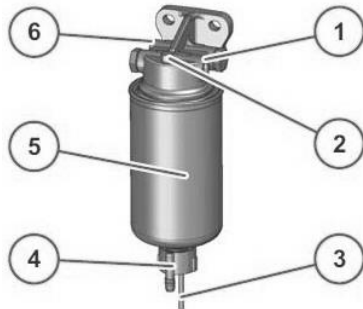

- (1) Pump fuel supply
- (2) Bleed screw
- (3) Electric connection for the water level sensor
- (4) Drainage cap
- (5) Filter cartridge
- (6) Fuel tank inlet

Stop the engine.

Block the fuel intake to the engine (if the tank is positioned at the top).

Place a suitable container.

Disconnect the cables.

Slacken the drainage cap and drain out the liquid.

Remove the filter element.

Wipe the surface of the new filter cartridge and the opposite side of the filter head to remove dirt.

Slightly dampen the surfaces of the filter cartridge with fuel and re-screw the filter head clockwise (17-18 Nm).

Fit the drainage cap by applying a tightening torque of  $1.6 \pm 0.3 \text{ Nm}$ .

Connect the cables.

Open the fuel cock and bleed the system.

#### Parker Fuel pre-filter replacement.

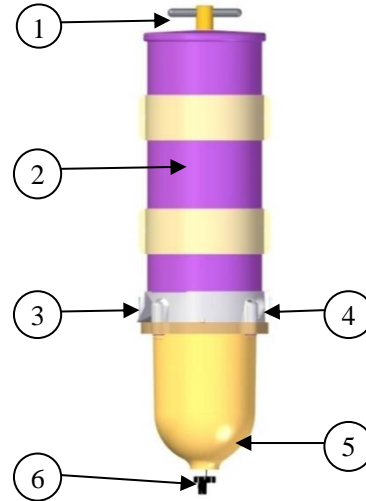

- (1) Joystick
- (2) Filter cartridge
- (3) Pump fuel supply
- (4) Fuel tank inlet
- (5) Plug
- (6) Drainage cap

Stop the engine.

Block the fuel intake to the engine (if the tank is positioned at the top).

Place a suitable container.

Disconnect the cables.

Slacken the drainage cap and drain out the liquid.

Remove the filter element.

Wipe the surface of the new filter cartridge and the opposite side of the filter head to remove dirt.

Slightly dampen the surfaces of the filter cartridge with fuel and re-screw the filter head clockwise (17-18 Nm).

Fit the drainage cap by applying a tightening torque of  $3.5 \sim 4 \text{ Nm}$ .

Connect the cables.

Open the fuel cock and bleed the system.

## Maintenance

### D-4 Engine radiator - Cleaning

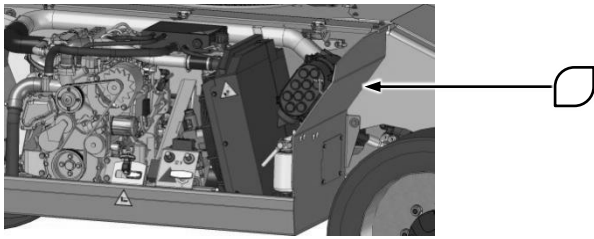

To remove dust and debris from the radiator mass, compressed air, pressurised water or steam can be used. However, it is preferable to use compressed air.

**When using pressurised water, keep the high pressure jet cleaning nozzles at a distance of at least 50cm from the radiator mass. Bringing the nozzle too close to the radiator mass can lead to risk of damaging the radiator.**

### D-5 Turret rotation slewing ring gear - check tightening of bolts

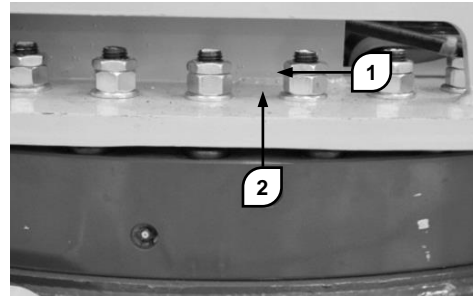

Check the turret fixing nuts on the slewing ring gear. Check for rusted, slackened or missing nuts.

Contact your dealer in case of serious problems.

To check the tightening torque slacken lock nuts 1. Tighten nuts 2 by applying a 290 Nm torque. Again tighten lock nut 1. The help of a second operator may be necessary to hold the screw steady.

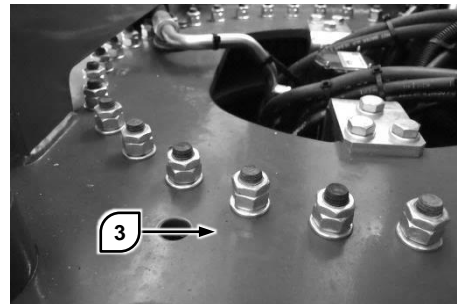

To check the fixing screws of the slewing ring gear on the chassis, align hole 3 with the screw underneath by rotating the turret.

Tighten the screws by applying a 290 Nm torque. Repeat the operation for each screw, rotating the turret from time to time.

## Maintenance

### 12.3.5 Checklist E Procedures

#### E-1 Fuel filter - replacement

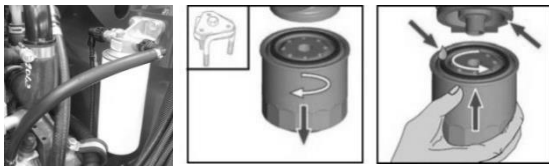

Slacken the filter using the tool and unscrew it.

Collect the fuel that flows out.

Wipe the surface of the filter-holder with a clean cloth that does not leave lint.

Oil the original DEUTZ filter cartridge seal slightly.

Screw the manual filter by hand until it is tight

Tighten the clamps of the anti-twisting safety (optional).

Bleed the fuel supply system.

#### E-2 Air filter - replacement of primary cartridge

The efficiency and life of the engine depend greatly on the quality of air taken in. A dirty or damaged air filter can seriously affect the correct working of the engine and increase the possibility of a fault.

Replace the air filters strictly according to the schedule indicated in this Manual. Do not try to wash dirty filters.

If the machine is expected to be used in environments with a lot of dust or high concentrations of contaminating or polluting agents in the air, halve the time interval between one filter replacement and the next.

#### Replacing the primary cartridge

To access the filter housing, open the engine compartment

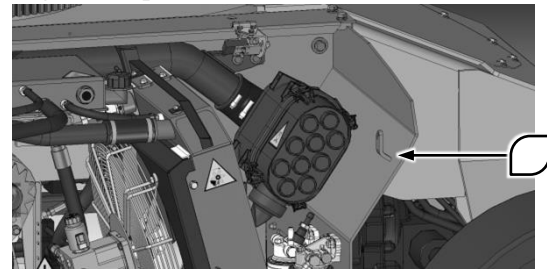

Release the catches and remove the cover on the front of the filter.

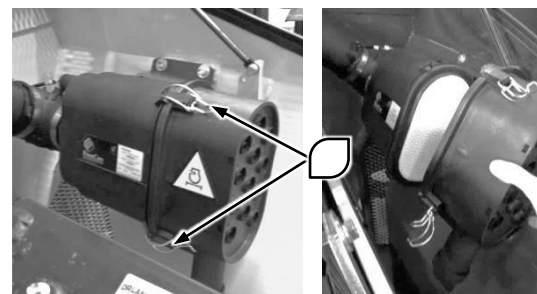

Grip the filter element and remove it from its seat.



Wipe thoroughly inside the filter housing with a damp cloth. Avoid the use of aggressive solvents or products as these can damage the safety filter or the filter housing.

Install a new filter element. Make sure the filter element is inserted properly in its seat. If installation is difficult, grease the rubber gasket slightly with silicone grease.

## Maintenance

### E-3 Differentials oil - Change

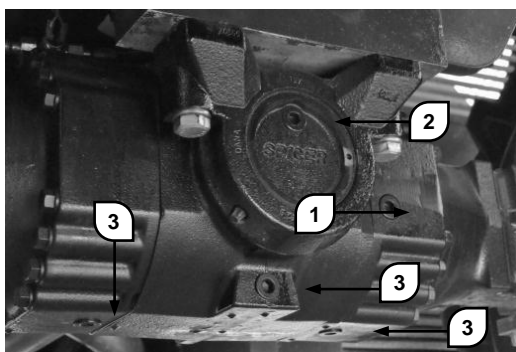

Place suitable sized containers under the axle. Remove the three drainage caps of the differential 3. 2. Wait for the oil to drain out completely. To speed up the operation, remove filler cap 2.

Refit caps 3 and tighten adequately. Remove level cap 1.

Pour fresh oil of the correct type through hole 2. Fill in stages and check the flow of oil through level hole 1.

When the correct level is reached, refit level cap 1 and filler cap 2.

### E-4 Wheel reduction gears oil -Change

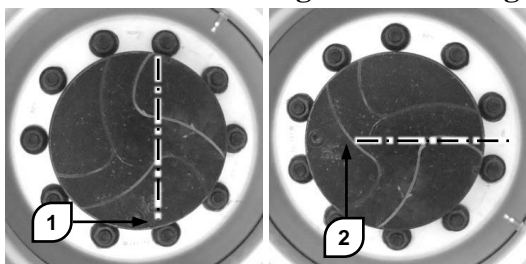

Place a suitable sized container under the reduction gear. Turn the reduction gear cap in position 1.

Remove the cap and wait for the oil to drain out completely.

Turn the reduction gear cap in position 2. Fill oil through the hole to the correct level. Refit the cap. Repeat this operation for each wheel.

### E-5 Telescopic boom sliding blocks - Adjusting the play

Park the vehicle in a suitable sized area. Remove the accessory from the quick-fit coupling. Centre the turret and set the telescopic boom in the horizontal position. Retract the telescopic boom completely.

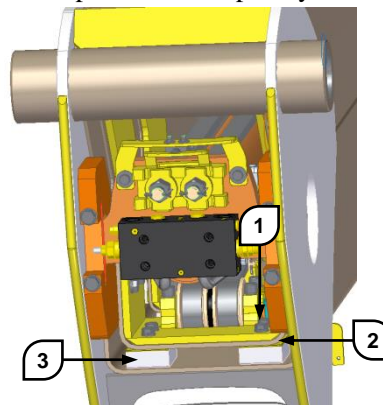

Remove the cover on the rear part of the boom.

Slacken all the bolt 1 of the upper and lower sliding blocks of the first extension stage. If the space between the sliding surface of the block 3 and the sliding surface of the first boom exceeds 0.5mm, some pads 2 need to be added. And then tighten bolts 1.

Tightening torque: 100 Nm.

Repeat the adjustment operations for the lateral sliding blocks.

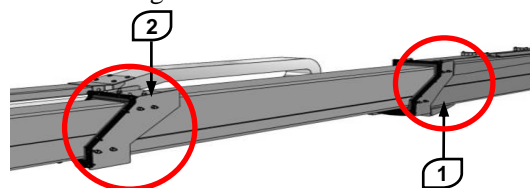

Move to the front of the boom, and identify the sliding blocks of the first extension stage.

Slacken all the bolt 1 of the upper and lower sliding blocks of the first extension stage. If the space between the sliding surface of the block 3 and the sliding surface of the first boom exceeds 0.5mm, some pads 2 need to be added. And then tighten bolts 1.

Tightening torque: 100 Nm.

Repeat the adjustment operations for the lateral sliding blocks.

## Maintenance

Repeat the operations described above for the sliding blocks of all the extension stages, proceeding in order towards the front part of the boom.

Always try to adjust the sliding blocks symmetrically, so that each stage is centered with respect to the adjacent ones.

After completing the operations try to extend and retract the boom to check the boom movement is smooth. If the movement of the boom is not smooth, repeat the adjustments.

### E-6 Turret rotation slewing ring gear - change reduction gear oil - check play

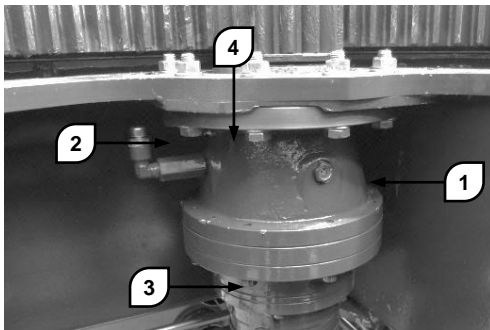

Place a suitable sized container under the bleed cap 3. Unscrew the cap and drain out the oil.

Close the drainage cap 3. Add oil through the filler hole 2 up to the prescribed level visible through the transparent bush 1.

Lubricate the reduction gear shaft bushes by injecting grease into grease nipple 4.

### Check the slewing ring gear bearings for wear

The factory setting of the play of the bearings is between 0.05 and 0.25 mm. The slewing ring gear must be replaced if the wear limit value exceeds 2.2 mm; to check the bearings for wear, proceed as described below.

1. Park the vehicle stably on level ground, align the turret to the chassis axis, without load.

2. Lubricate both the turret axial bearing tracks by means of the two grease nipples

provided inside, and apply grease manually to the outer teeth of the slewing ring gear using a brush. Refer to chapter B-6 for the grease brand. Check tightening of bolts fastening turret rotation slewing ring gear, referring to chapter D-5.

3. Start the machine from the ground controls and fully elevate, but do not extend, the primary boom and jib. The riser should remain in its stowed position.

4. Place a dial indicator with accuracy of 0.01mm, between the drive chassis and the turntable at a point that is directly under, or in line with, the boom and no more than 1inch/2.5cm from the bearing.

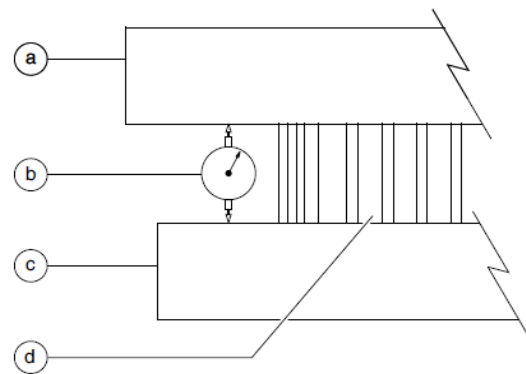

a turret

b dial indicator

c drive chassis

d turret rotation bearing

5. Adjust the dial indicator need to the “zero” position.

6. Elevate the riser, but do not extend it. Move the primary boom and jib to horizontal and fully extend.

7. Note the reading on the dial indicator. If the measurement is less than 2.2mm, the bearing is good. Otherwise, the bearing is worn and needs to be replaced.

8. Remove the dial indicator and rotate the turntable 90°.

9. Repeat steps 4 through 8 until the rotation bearing has been checked in at least four equally spaced areas 90° apart.

10. Lower the boom to the stowed position.

## Maintenance

### E-7 Overload Sensor - calibration

How much the load weighted by the overload sensor is in the platform will be indicated on the panel on the ground control console. If the load in the platform does not exceed rated load, the vehicle is safe during work. Otherwise, it is dangerous and the alarm will be activated. So, the sensor must be calibrated when the data showed on the panel is incorrect.

#### Calibration

The weighting system must be calibrated termly. The interval is 1000 hours for running or every year. Besides, stop to calibrate the overload sensor at once the data showed on the panel is incorrect.

### 12.3.6 Checklist F Procedures

#### F-1 Fuel filter - clean mesh element

It is important for operating life of the vehicle to clean the fuel suction mesh element. The pressure of fuel suction would be higher when the mesh element is dirty, which will damage the engine and shorten the operating life of the vehicle. The procedures of cleaning the mesh element as follows

1. Remove the cover of hydraulic tank.

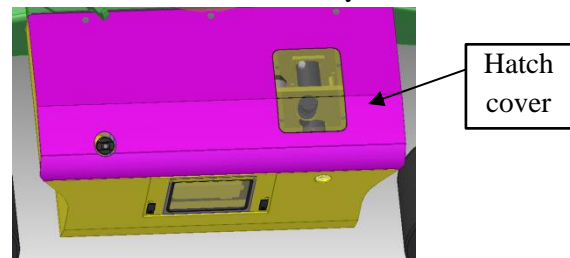

2. Slacken the bolts of fastening the fuel sucking pipe and pull out the fuel sucking pipe.

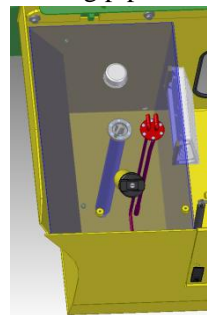

3. Remove the mesh element.

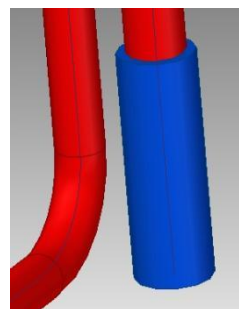

4. Clean the mesh slightly. The corrosive chemical solvent should be forbidden to use.

Replacing the mesh should be performed when the mesh is too dirty to clean or damaged. Please refer to DingLi for mode of the mesh.

5. Refit the mesh after completing cleaning and blowing with pressured air.

## Maintenance

### 12.3.7 Checklist G Procedures

#### G-1 Hydraulic fluid - change

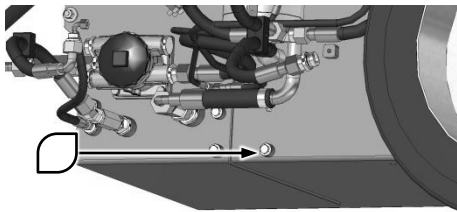

1. Go under the vehicle to access the tanks drainage caps.
2. Place a suitable sized container under the drainage cap. Unscrew the cap and drain out the oil. To speed up the operation, also unscrew the filler cap.
3. Install the plug on the drain port. Fill the tank with hydraulic oil filtered with a 20um filter and applied to the local environment until the level is correct. Not overfill.
4. Look around for enough space for extending and lifting completely.
5. Place a suitable sized container under the PVG.
6. Disconnect the lifting down hose from B port of PVG and block the B port with plug.
7. Start the engine, and lift up the boom completely to lead the oil from the cylinder rod chamber into the container.
8. Recover the hose.
9. Repeat the step 4-8 for leading oil out from the other cylinder rod chamber.
10. Park the vehicle and check the hydraulic oil level. Add it, if necessary.

#### G-2 Air filter - replacing the safety cartridge

Carry out the primary filter removal procedure described earlier.

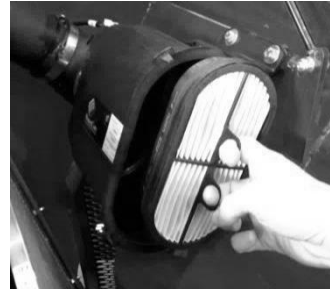

- Hold the filter element by means of two fingers in the grips and pull to separate it from its seat.
- Wipe thoroughly inside the filter housing with a damp cloth. Avoid using aggressive solvents or chemical products as these can damage the filter casing.
- Install a new filter element. Grease the outer gasket of the new filter element slightly with silicone grease.





**ZHEJIANG DINGLI MACHINERY CO., LTD.**

1255 Baiyun Road, Leidian Town, Deqing County, Huzhou City, Zhejiang Province, China

After-sales service department

**Telephone:** 0572-8681638、0572-8681639

**Website:** [www.cndingli.com](http://www.cndingli.com)

**E-mail:** [service@cndingli.com](mailto:service@cndingli.com)



First edition printed in March 2020