



# *Operation Manual*

**BS EN 280-1:2022**

**AR20J**

**Mobile Elevating  
Work Platforms**

**PART No. OM- 2537050111**

**Original Instructions**

## Original Instructions

Thank you for choosing to use this Mobile Elevating Work Platform from LGMG. All models are designed and manufactured according to BS EN 280-1:2022, All dealers, owners, users, operators, lessors, lessees, and brokers to comply with appropriate section(s) of applicable BS EN 280-1:2022 standards.

This manual is a guide for safe and proper operation and maintenance of the machine, which introduces technical parameters and mechanism and operation herein.

We sincerely hope that you will read through this manual before attempting to operate the machine for the first time and before repairing and maintaining the machine, and that you will master the operation and maintenance described therein.

The information contained in this manual is correct at the time of publication. However, LGMG has endeavored to deliver the highest degree of accuracy possible. And continuous improvement of our product is a LGMG policy. Therefore, product specifications are subject to change without notice.

Due to the impossibility of foreseeing all possible hazards, therefore, it is not possible to include all safety precautions in this manual and the machine's safety precautions in this manual and the machine's safety instructions. If some operations that are not recommended in this manual, you must ensure that you and others are safe and will not damage the machine. If the security of certain operations cannot be determined, please call LGMG industries or dealer service center.

The precautions for operation and maintenance contained in this manual are only applicable when the machine is used for the specified use. If the machine is used within the scope not listed in this manual, our company will not assume any safety responsibility, which is borne by the user and operator in such operations.

Any prohibited operations in this manual shall not be performed.

This manual should always be placed in the designated location for read. This manual is part of the machine, when the ownership or use right of the machine is transferred, please hand over this manual together. If the manual is lost, damaged or illegible, please replace it promptly.

The copyright of this manual this manual is authorized to LGMG and it cannot be copied or reprinted without LGMG's written permission.

2025-03 Version 1 Printed 1

---

**L I N G O N G   H E A V Y   M A C H I N E R Y   C O . , L T D .**

Add: 2676 Kejia Road, high tech Zone, Jinan City, Shandong Province, China

Tel: 86-0531-67601108

Fax: 86-0531-67601108

Service Tel: 86-0531-67605016

Web: [www.lgmg.com.cn](http://www.lgmg.com.cn)



# Contents

Contents.....	I
Safety Notices.....	V
Chapter 1 Safety.....	2
1.1 Hazards.....	4
1.2 Before Operation, Please Ensure that:.....	4
1.3 Classification of Hazards.....	4
1.4 Intended Use.....	4
1.5 Safety Sign Maintenance.....	4
1.6 Electric Shock Hazard.....	5
1.7 Danger of Tip-over.....	5
1.8 General Safety.....	7
1.9 Operating Hazards on Slopes.....	7
1.10 Falling Hazard.....	8
1.11 Collision Hazard.....	8
1.12 Components Damage Hazard.....	8
1.13 Explosion and Fire Hazards.....	8
1.14 Machine Damage Hazard.....	9
1.15 Danger of Bodily Injury.....	9
1.16 Battery Safety.....	9
1.17 Locked After Each Use.....	10
1.18 Personal Fall Protection.....	10
1.19 Ground Information.....	10
Chapter 2 Legend.....	12



## Operation Manual of Articulated Boom Mobile Elevating Work Platform

---

Chapter 3 Label .....	16
Chapter 4 Overall Machine Parameters .....	22
Chapter 5 Control Box .....	34
5.1 GCU .....	36
5.2 PCU .....	38
5.3 Control Logic (SPD) .....	42
Chapter 6 Pre-operation Inspection .....	44
6.1 Before Performing This Operation, Ensure that .....	46
6.2 Basic Principles .....	46
6.3 Pre-operation Inspection .....	46
6.4 Pre-operation Inspection of Safety Protection Devices (SPD) .....	47
Chapter 7 Workplace Inspection .....	48
7.1 No Operation Is Allowed Unless .....	50
7.2 Basic Principles .....	50
7.3 Workplace Inspection .....	50
Chapter 8 Functional Testing .....	52
8.1 Basic Principles .....	54
8.2 At GCU .....	54
8.3 On the Platform .....	54
8.4 Verification Procedures for Safety Protection Devices (SPD) .....	57
Chapter 9 Operating Instructions .....	58
9.1 No Operation is Allowed Unless .....	60
9.2 Basic Principles .....	60
9.3 Starting the Engine .....	60
9.4 Emergency Shutdown .....	60



**Operation Manual of Articulated Boom  
Mobile Elevating Work Platform**

---

9.5 Emergency Power.....	61
9.6 Operation on the Ground .....	61
9.7 Operation on the Platform.....	61
9.8 Platform Overload .....	63
9.9 Machine Not Level .....	63
9.10 Function of Safety Protection Devices (SPD).....	64
9.11 DPF Regeneration (If Equipped) .....	65
9.12 Machine Safety System Override (MSSO) .....	67
9.13 System Failure .....	67
9.14 After Each Use .....	69
Chapter 10 Transportation Instructions .....	70
10.1 Observing the Regulations .....	72
10.2 Brake Release.....	72
10.3 Ensuring Transportation Safety .....	72
10.4 Guidance for Lifting .....	73



**Operation Manual of Articulated Boom  
Mobile Elevating Work Platform**

---



## Safety Notices

Operators should understand and follow the current national and local safety regulations, and use the safety instructions in this manual if there are no corresponding regulations.

Most accidents are caused by the user's violation of the regulations on machine operation and maintenance. To avoid accidents, please read, understand and comply with all requirements, precautions and warnings in this manual and machine labels before operation and maintenance.

This manual is not a training manual for elevating work platform operators! All operating instructions are for professionals who have received elevating work platform relevant training.

Since it is impossible to foresee all possible hazards and accidents, the safety instructions in this manual cannot include all safety precautions, and other existing safety risks must be taken into account in the actual operation. If a procedure or operation not recommended in this manual is used, the operator must carry out a risk assessment and must ensure the safety of himself and others and that no damage is done to the machine. If the safety of some operations is not certain, please contact our company or dealer.

If the content of this manual is inconsistent with the standards or laws and regulations issued by the local government or authorities, please enforce the stricter policy.

The operation and maintenance precautions given in this manual are only applicable to the specified use of this machine. If the machine is used outside the specified purpose, our company will not assume any responsibility, and all responsibilities shall be borne by the user and the operator.

In any instance, the prohibited operations in the manual can not be carried out.

The following markers are used to identify safety information in this manual:

 **DANGER** - Indicating any dangers that, if not avoided, will cause serious injury or even death, and also serious machine damage.

 **WARNING** - Indicating any dangers that, if not avoided, may cause injury, serious injury or even death, and also serious machine damage.

 **CAUTION** - Indicating dangers that, if not avoided, may cause minor or moderate injury, and also machine damage or shortened machine service life.



# Operation Manual of Articulated Boom Mobile Elevating Work Platform

---



# **Chapter 1 Safety**



**Operation Manual of Articulated Boom  
Mobile Elevating Work Platform**

---



## 1.1 Hazards

 **WARNING: Failure to follow the instructions and safety rules in this manual may result in serious injury or death. Alcoholics, drug addicts, and those taking reaction inhibiting drugs are strictly prohibited from approaching and operating the machine.**

## 1.2 Before Operation, Please Ensure that:

- 1) Equipped with PFPE, such as helmet, seat belt, safety shoes, goggles, protective gloves, etc., and in good physical condition.
- 2) You have understood and implemented the safety rules for machine operations in this Operation Manual.
- 3) Know and understand the rules for safe operation of the machine before proceeding to the next step.
- 4) Always perform the check before the operation.
- 5) Always perform a functional test before use.
- 6) Check the workplace.
- 7) Use the machine only for specified purposes.
- 8) All applicable laws and regulations shall be read, understood and complied with.
- 9) Been trained to operate the machine safely.

## 1.3 Classification of Hazards

Symbols, color codes and symbolic words used in LGMG products have the following meanings:

- 1) Safety warning sign - used to warn of potential personal injuries. Observe all safety tips at the back of the sign to avoid possible personal injury or death.



- 2) Red indicates a dangerous situation. If it is not avoided, it will lead to death or serious injury.



- 3) Orange indicates a dangerous situation. If not avoided, it may cause death or serious injury.



- 4) Yellow indicates a dangerous situation. If not avoided, it may cause minor or moderate personal injury.

**Notice**

- 5) Blue indicates a dangerous situation. If not avoided, it may result in property loss.

## 1.4 Intended Use

The use of this machine is limited to lifting personnel and their tools and materials to workplaces at heights and it can be used indoors and outdoors.

 **WARNING: It is strictly forbidden to modify the machine without permission, carry goods, and hang or lift articles.**

## 1.5 Safety Sign Maintenance

- 1) Replenish missing and replace damaged safety sign.
- 2) Clean the safety sign with neutral cleaning agent or clean water.



- 3) Solvent-based cleaners may damage the safety sign. Do not use solvent-based cleaners to clean the safety sign.

## 1.6 Electric Shock Hazard



**WARNING: This machine is not insulated and does not provide shock protection when in contact with or near wires, power supplies or electrical equipment.**



- 1) Please maintain a sufficient safe distance from the wires, power supplies and power equipment in accordance with applicable laws and regulations and the following table.

Voltage	Required safety distance
0-50 KV	3.05m
50 KV-200 KV	4.60m
200 KV-350 KV	6.10m
350 KV-500 KV	7.62m
500 KV-750 KV	10.67m
750 KV-1,000 KV	13.72m



**CAUTION: The influence of strong wind or gust on the movement of the platform, the swing and relaxation of wires should be considered.**

- 2) If the machine comes into contact with live wires, immediately keep away from the machine.
- 3) Before cutting off the power supply of wires, it is forbidden for personnel to come in contact with or operate the machine.
- 4) Do not operate and use the machine in

case of lightning or storm.

- 5) Do not use the machine as a ground wire during welding.

## 1.7 Danger of Tip-over

- 1) The total weight of the personnel, equipment and materials on the platform shall not exceed the maximum bearing capacity of the platform.
- 2) Never overload the platform.



- 3) Only when the machine is on solid, flat ground can the boom be raised and extended.

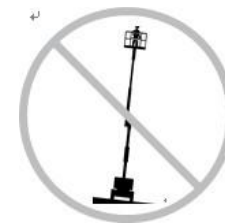

- 4) If the platform is overloaded, the buzzer will alarm. Please reduce the platform load first.
- 5) When the platform is raised, the speed of the machine shall not exceed 0.8 km/h.
- 6) The tilt sensor cannot be considered as a level indicator. The buzzer on the rotary table will only sound when the machine is heavily tilted.
- 7) If the buzzer sounds when the platform is lifted, be very careful, as the Machine not level indicator lamp will come on and the drive function will not be available in both directions. First determine the state of the boom on the slope, as shown below. Then lower the boom as follows before moving the machine to a solid, level ground. Do not rotate the boom when lowering.



## Operation Manual of Articulated Boom Mobile Elevating Work Platform

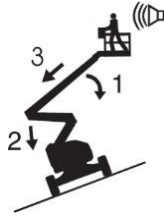

If the buzzer sounds when the platform goes uphill

- ① Lower the primary boom
- ② Lower the secondary boom
- ③ Retract the primary boom



If the buzzer sounds when the platform goes downhill

- ① Retract the primary boom
- ② Lower the secondary boom
- ③ Lower the primary boom

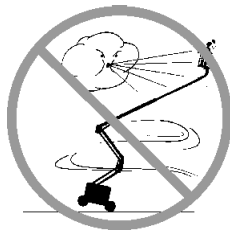

- 8) Do not raise the boom when the wind speed may exceed 12.5 m/s. If the wind speed exceeds 12.5 m/s after the boom is raised, lower the boom and do not continue to operate the machine.
- 9) Do not operate the machine in strong wind or gust. Do not increase the surface area of the platform or load. Increasing the area exposed to the wind will reduce the stability of the machine.
- 10) When the platform is tripped, stuck, or other nearby objects hinder its normal movement, do not use the PCU to operate the machine. If you intend to operate the machine by using the GCU, you must operate it after all personnel have left the platform.



- 11) Always follow your national traffic regulations.
- 12) Be very careful and reduce the speed when the machine is driven on a surface with crushed stone, unstable or slippery or near a hole or on a steep slope in the stowed state.
- 13) When the boom is raised, the machine cannot be driven on uneven terrain, unstable surfaces or other dangerous conditions, or near these areas.



- 14) Do not push or pull any object outside the platform. The maximum allowable manual force of the machine is 400 N.
- 15) The machine cannot be used as a crane.



- 16) Do not place, tie down or hang loads on any part of the machine.
- 17) Do not push machine or other objects with boom.
- 18) When the vehicle goes downhill, please operate in the low speed range, and it is forbidden to go downhill at high speed.
- 19) When the vehicle is driving on a slope, it is forbidden to use the emergency stop switch.



## 1.8 General Safety

- 1) The machine cannot be operated with the hood open.
- 2) Do not allow boom to approach or touch any objects.
- 3) All sensors such as those for angle, inclination, weighing shall not be changed or disabled.
- 4) Boom or platforms must not be bound to adjacent objects.



- 5) Do not modify this machine without the prior written permission of the manufacturer. Installing additional devices for placing tools or materials on platform, pedals or guardrails will increase the weight and surface area of the platform.
- 6) Ladders or scaffolding shall not be placed in the platform or against any part of the machine.
- 7) Only tools and materials that are evenly distributed and can be safely moved by people on the platform can be transported.
- 8) Do not use machines on moving or shaky surfaces or on vehicles.
- 9) Do not place hands and arms close to areas with danger of cutting or smashing.
- 10) Do not change or damage any component that may affect the safety and stability of the machines.
- 11) Key part affecting the stability of the machine shall not be replaced with part of different Spec.
- 12) Ensure that all tires are in good condition and the nuts are properly tightened. Do not replace the original tire with a tire of different Spec.
- 13) The ambient temperature for the use of the machine shall be  $-20\text{ }^{\circ}\text{C} \sim 40\text{ }^{\circ}\text{C}$ , and the relative humidity should not be greater than



90% (at  $20\text{ }^{\circ}\text{C}$ ).

- 14) Ensure that this manual is kept in the file box in the platform.
- 15) Total vibration value to which the hand/arm system is subjected does not exceed  $2.5\text{ m/s}^2$ . Highest root mean square value of weighted acceleration to which the whole body is subjected does not exceed  $0.5\text{ m/s}^2$ .

## 1.9 Operating Hazards on Slopes

Do not drive the machine on a slope that exceeds the maximum uphill, downhill or side slope rated value of the machine. Slope rating is only applicable to machines in stowed state.

The maximum slope rating when the boom is stowed is as follows

Item	Parameters
	AR20J
 Platform in downhill direction	45%(24°)
 Platform in uphill direction	30%(17°)
 Platform side slope	25%(14°)

**⚠ CAUTION: Slope rating is limited by ground condition and traction. Refer to Driving on Slopes in the Operating Instructions section of this manual.**

**⚠ Danger of Sliding Slope:**

**When the machine is working on a**



slope exceeding the maximum and rated gradation, a slip may occur. A slip may lead to death or serious injury.

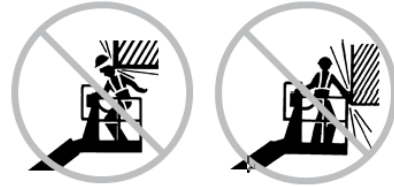

## 1.10 Falling Hazard

- 1) During the operation, the staff on the platform must wear PFPE, such as helmet, safety belt and safety shoes according to the site needs, and use, inspect, and regularly replace them according to the manufacturer's instructions.



**WARNING: Seat belt hooks must be fixed to approved rope fixing points, and only one hook can be tied to each rope fixing point.**



- 2) Do not sit, stand or climb on the protective fence of the platform. Stand stably on the platform floor at all times.
- 3) Never get on or get off the platform when the platform is raised.
- 4) When the platform is lifted, it is not allowed to climb down from the boom.
- 5) Keep the platform floor free of debris, sundries, grease and other slippery substances.
- 6) Please close the entrance door before operation.
- 7) Do not enter or leave the platform unless the machine is tucked up.

## 1.11 Collision Hazard

- 1) Exercise good judgment and planning when operating machines on the ground. Keep a safe distance between the operator, the machine and the object.
- 2) When starting or operating the machine, pay attention to the sight range and the existence of blind spots.

- 3) When rotating the rotary table, pay attention to the position of the boom and rotary table swing tail.
- 4) Check the work area to avoid obstacles or other possible dangers overhead.
- 5) Beware of the squeezing danger when grasping the platform fence.
- 6) When there are no people and obstacles in the lower area, the boom can be lowered.
- 7) Limit travel speed according to ground conditions, congestion level, slope, personnel position and any other factors that may cause collision.
- 8) The machine cannot be operated on the route of any crane or mobile overhead machinery unless the crane controller is locked or precautions have been taken to prevent any potential collision.
- 9) Do not operate the machine dangerously or playfully.
- 10) Users must abide by the user rules, workplace rules and government rules for personal protection equipment.
- 11) Attention shall be paid to the direction of driving and steering function.

## 1.12 Components Damage Hazard

- 1) Do not use any battery or charger greater than 12 V to start the engine.
- 2) Do not use the machine as a ground wire during welding.
- 3) Do not use the machine where magnetic fields may exist.

## 1.13 Explosion and Fire Hazards

- 1) Do not operate the vehicle where it is dangerous or where flammable or explosive gases or particles may be



## Operation Manual of Articulated Boom Mobile Elevating Work Platform

present.

- 2) Do not start up the engine if liquefied petroleum gas (LPG), gasoline, diesel, or other explosive substances are present.
- 3) Do not refuel the machine when the engine is running.
- 4) Only refuel the machine in open and well-ventilated places far away from sparks, open flames, burning cigarettes, etc.

### 1.14 Machine Damage Hazard

- 1) A machine that have been damaged or faulty shall not be used.
- 2) The machine shall not be used where strong magnetic fields, strong ionization and radioactive radiation may exist.
- 3) Before every shift, the pre-operation inspection of the machine shall be strictly carried out and all functions shall be tested. The damaged or faulty machine shall be marked immediately and the operation shall be stopped.
- 4) Ensure that all inspections and maintenance have been carried out as specified in this manual.
- 5) Ensure that all labels are located properly and easily identified.

### 1.15 Danger of Bodily Injury



- 1) Please do not operate the machine when the hydraulic oil leaks. Hydraulic oil leakage may penetrate or burn the skin, and the goggles and protective gloves must be worn when checking the hydraulic oil leakage.
- 2) Incorrect contact with any components under the hood will result in serious injury, and only trained maintenance personnel can open the hood for overhaul. The hood can be opened by the operator for inspection only when the pre-run inspection

is carried out. All hoods must remain closed during operation.

- 3) It is forbidden to carry out maintenance work when the equipment hydraulic system is under pressure.
- 4) Always operate the machine in a well-ventilated area to avoid of carbon monoxide poisoning.

### 1.16 Battery Safety

#### Danger of Burns



- 1) Lead-acid battery contains acid. Wear protective clothing and protective glasses when maintaining battery.
- 2) Avoid spillage or contact with acidic substances in the battery. Use soda and water to neutralize spilled battery acid.
- 3) When cleaning the vehicle, it is forbidden to directly flush and wash the battery and other electrical components.
- 4) Disconnect the main power switch when transporting, repairing or parking the vehicle for a long time.

#### Explosion Hazard

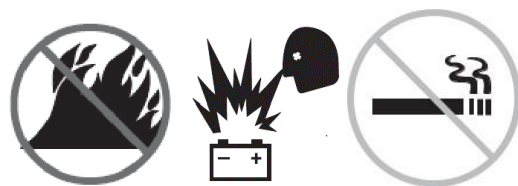

- 1) Sparks, flames and lit cigarettes are prohibited from getting close to the battery. The battery can release explosive gases.
- 2) Do not touch battery terminals or cable clamps with tools that may cause sparks.

#### Electric Shock/Burn Hazard

- 1) Check cables, wires and wiring daily for damage. Replace damaged items before operation.
- 2) Avoid electric shock due to contact with



battery terminals. Remove all rings, watches and other accessories.

### 1.17 Locked After Each Use

- 1) Choose a safe parking place, which can be a solid level ground without obstacles and avoid places where transportation is busy.
- 2) Retract and lower the boom to the stowed position.
- 3) Rotate the rotary table so that the boom is located between the two tire of the rear axle.
- 4) Turn the key switch to the "off" position and remove the key to avoid unauthorized use.
- 5) Cushion the wheel with a wedge.
- 6) Cut off the power when the machine is repaired or not used for a long period.

### 1.18 Personal Fall Protection

- 1) The personal fall protection equipment (PFPE) is required when this machine is operated.
- 2) Personnel on the platform must wear a seat belt or use safety facilities that comply with government regulations. Tie the lanyard to the lanyard fixing point of the platform.
- 3) Users must abide by user rules, workplace rules and government rules regarding the use of personal protection equipment.
- 4) All PFPEs must comply with the corresponding government regulations and must be inspected and used according to the PFPE manufacturer's instructions.

### 1.19 Ground Information



**WARNING: Rollover and personal**

**injury will be caused under severe working conditions and complex and unsafe ground conditions, and stable ground conditions and good working conditions can ensure the normal operation of the machine; therefore before operation, verify that the ground in the working area is safe and**

**strong enough to support the machine.**



**DANGER: Rollover and personal**

**injury may occur under the following conditions:**

- **On steep slopes or in caves;**
- **When there are protrusions, obstacles or debris on the ground;**
- **On the inclined surface;**
- **On the unstable or smooth surface;**
- **Near the mining area where the soil foundation is soft soil;**
- **On saturated soil or frozen soil;**
- **On suspended floor;**
- **On kerbs and road edges;**
- **On surface support that is not strong enough to withstand the full load of the machine;**
- **Under other possible unsafe situations.**

The ground load bearing information of the

machine is shown in the table below:

Model	Tire contact pressure	Occupied floor pressure
AR20J	523.12 kPa	11.02



**CAUTION: The ground load bearing information given herein is for reference only, and does not consider the optional devices of the machine. Before using the machine, always verify that the ground of the working area is safe and strong enough to support the machine.**



## Operation Manual of Articulated Boom Mobile Elevating Work Platform

---

### Tire specification:

Model	Drive wheel load-5km/h (kg)	Maximum static load (kg)
AR20J	5300	7000



## **Chapter 2 Legend**



**Operation Manual of Articulated Boom  
Mobile Elevating Work Platform**

---



## Operation Manual of Articulated Boom Mobile Elevating Work Platform

**⚠ CAUTION:** The product structure diagram of AR20J is shown here. For other models, please refer to this diagram.

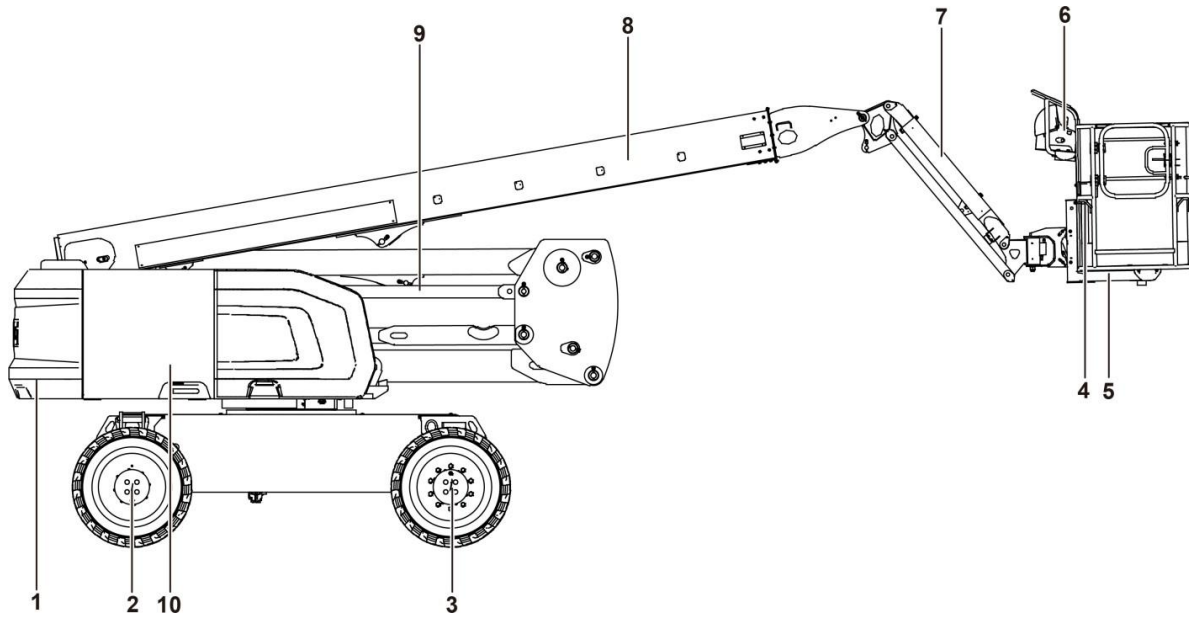

Fig. 2-1 Side view of complete vehicle

No.	Description	No.	Description
1	Counterweight	6	PCU
2	Front axle	7	Jib
3	Rear axle	8	Base boom
4	Lanyard fixing point	9	Tower boom
5	Platform	10	Engine side



**Operation Manual of Articulated Boom  
Mobile Elevating Work Platform**

---



## **Chapter 3 Label**



**Operation Manual of Articulated Boom  
Mobile Elevating Work Platform**

---



# Operation Manual of Articulated Boom Mobile Elevating Work Platform

## AR20J Labels

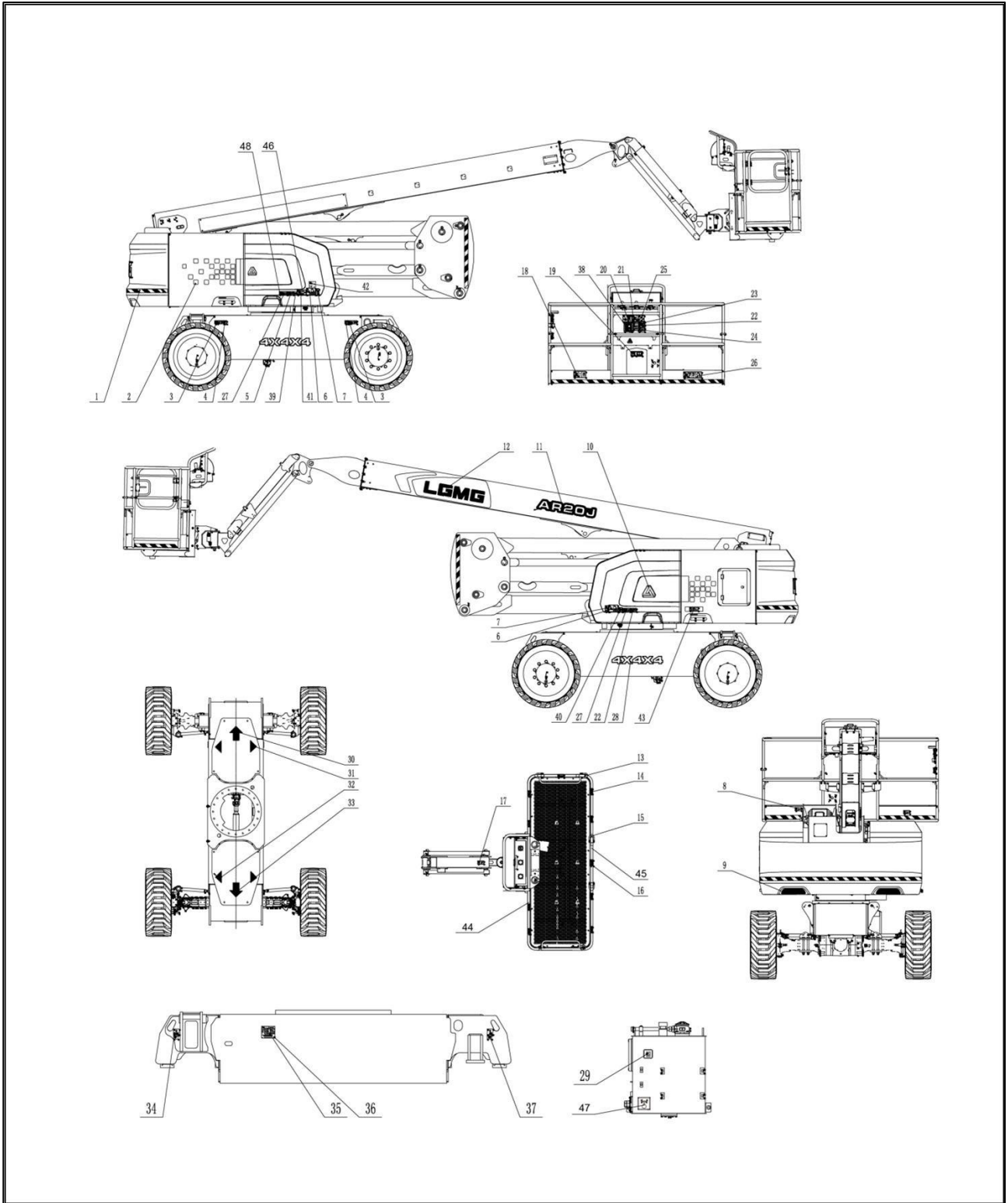

Fig. 3-1 Label position



## Operation Manual of Articulated Boom Mobile Elevating Work Platform

### AR20J Label information

Code	Coding	Name	Code	Coding	Name
1	2534000024	Decal-Warning line	25	2534000063	Decal-Tip-over warning when going uphill and downhill
2	2534000194	Decal-Company logo-left	26	2534003267	Decal-Double load
3	2534000045	Decal-"Replace tire" warning	27	2534000011	Decal-In-box maintenance warning
4	2534002692	Decal-Wheel load	28	2534003143	Decal-4*4*4
5	2534000026	Decal-"Read manual" warning	29	2534001995	Decal-Hydraulic oil
6	2534000048	Decal-Electric shock warning	30	2534000053	Decal-Arrow
7	2534000043	Decal-Crushing hazard	31	2534000050	Decal-Arrow
8	2534000041	Decal-Keeping away from machine warning	32	2534000051	Decal-Arrow
9	2534002657	Decal-Reflective stickers	33	2534000052	Decal-Arrow
10	2534003551	Decal-Company logo-right	34	2534000027	Decal-Lifting
11	2534003550	Decal-Model	35	2534004111	Decal-Complete machine nameplate
12	2534001775	Decal-Company logo	36	4019000012	Decal-Rivet
13	2534001809	Decal-Anti-scratch sticker	37	2831990027	Decal-Lug
14	2534000017	Decal-Lanyard fixing point	38	2534003450	Decal-Working curve
15	2534000248	Decal-Anti-scratch sticker	39	2534000276	Decal-CE
16	2534000036	Decal-Lowering middle column warning	40	2534000177	Decal-Fuel tank
17	2534000042	Decal-Falling hazard	41	2534000004	Decal-Explosion burn warning
18	2534000037	Decal-Outdoor hand power	42	2534000786	Decal-107dB
19	2534000119	Decal-"Read manual" warning	43	2534002026	Decal-Power supply switch
20	2534002550	Decal-Ramp driving instructions	44	2534003641	Decal-Hand-hold position
21	2534000145	Decal-Warning	45	2534003478	Decal-Risk of pinching hand
22	2534000247	Decal-Electric shock hazard	46	2534004014	Decal-UKCA
23	2534000039	Decal-Tip-over warning	47	2534004387	Decal-Oil suction filter switch
24	2534003243	Decal-Instructions for use of differential lock	48	2534003337	Decal-Power supply switch











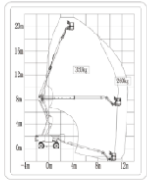

# Operation Manual of Articulated Boom Mobile Elevating Work Platform

## AR20J Label

1-2534000024	2-2534000194	3-2534000045	4-2534002692	5-2534000026	6-2534000048
7-2534000043	8-2534000041	9-2534002657	10-2534003551	11-2534003550	12-2534001775
				<b>AR20J</b>	<b>LGMG</b>
13-2534001809	14-2534000017	15-2534000248	16-2534000036	17-2534000042	18-2534000037
19-2534000119	20-2534002550	21-2534000145	22-2534000247	23-2534000039	24-2534003243
25-2534000063	26-2534003267	27-2534000011	28-25340003143	29-2534001995	30-2534000053
			<b>4X4X4</b>		
31-2534000050	32-2534000051	33-2534000052	34-2534000027	35/36-2534004111	37-2831990027

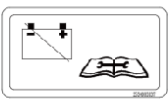

## Operation Manual of Articulated Boom Mobile Elevating Work Platform

38-2534003450	39-2534000276	40-2534000177	41-2534000004	42-2534000786	43-2534002026
					
44-2534003641	45-2534003478	46-2534004014	47-2534004387	48-2534003337	
					



## **Chapter 4 Overall Machine Parameters**



**Operation Manual of Articulated Boom  
Mobile Elevating Work Platform**

---



## Operation Manual of Articulated Boom Mobile Elevating Work Platform

### AR20J (A2012J0Wnk5CH7000) overall parameters

#### 4.1 Overall performance parameters

Item	Parameters	Item	Parameters	
Rated load (kg)	260	Rotary table slewing time per circle (stowed) (s)	80-110	
	2 people +100 kg	Rotary table slewing time per circle (Extend)( s)	122-155	
Limiting load (kg)	350	Rise time of main boom (s)	50-70	
	3 people +110 kg	Descent time of main boom (s)	50-70	
Overall weight (kg)	9850	Rise time of tower boom (s)	40-60	
Maximum working height (m)	21.58	Descent time of tower boom (s)	40-60	
Maximum platform height (m)	19.58	Boom extension time (s)	30-40	
Maximum horizontal extension (m)	12.37	Boom retraction time (s)	35-45	
Maximum span height (m)	8.19	Jib boom lifting time (s)	25-35	
Minimum turning radius (four wheels) (inner wheels) (m)	1.9	Jib boom lowering time (s)	20-35	
Minimum turning radius (four wheels) (outer wheels) (m)	3.9	Platform slewing time (s)	13-26	
Maximum driving speed (no-load, stowed) (km/h)	5±0.25	Maximum manual force (N)	400	
Maximum driving speed (deployment) (km/h)	0.8±0.05	Maximum allowable wind speed (m/s)	12.5	
Maximum braking distance (no-load, stowed) (m)	1≤S≤1.5	Theoretical maximum climbing ability (no-load, stowed)	45%	
Driving type	Four-wheel drive	Maximum allowable inclination angle of chassis	Along the boom	4°
	Four-wheel steering		Orthogonal to boom	4°
Turntable rotate angle (° )	360	Machine tail swing (mm)	975	
Secondary boom raise angle (° )	/	Jib boom raise angle (° )	120	
Jib boom rotate angle (° )	/	Platform rotate angle (° )	180	

#### 4.2 Main dimensions

Item	Parameters	Item	Parameters
Overall length (mm)	9420	Wheelbase (mm)	2510
Overall width (mm)	2500	Wheel track (mm)	2140
Overall height (mm)	2460	Ground clearance (mm)	400
Dimensions of working platform (L×W) (mm)	2440×900	Tire specification (diameter×width)(mm)	940×350

#### 4.3 Engine system



## Operation Manual of Articulated Boom Mobile Elevating Work Platform

Item	Parameters	Item	Parameters
Model	V2403-CR-E5B	Rated speed (r/min)	2600
Displacement (L)	2.4	Maximum torque (N.m)/speed (r/min)	159.8/1600
Rated power (kW)	36	Emission standard	EU stage V

### 4.4 Drive system

Item		Parameters/Content
Front axle	Speed ratio	21.81: 1
	Brake type	Multi-disc wet braking
Rear axle	Speed ratio	21.81: 1
	Brake type	Multi-disc wet braking

### 4.5 Hydraulic system

Item		Parameters/Content	
Functional system	Type	Open system	
	Pump displacement (ml/r)	20	
	Lifting system	Maximum working pressure (MPa)	23
	Slewing system	Maximum working pressure (MPa)	9
		Motor displacement (ml/r)	80
Steering system	Maximum working pressure (MPa)	15	
Driving system	Type	Closed system	
	Maximum working pressure (MPa)	40	
	Displacement of pump(ml/r)	56	
	Displacement of motor(ml/r)	63	

### 4.6 Electric system

Item		Parameters/Content
Battery	Output voltage (V)	12
	Capacity (Ah)	120
Control system	Voltage (V)	12

### 4.7 Filling volume

Item	Condition	Grade	Capacity	Remarks
Hydraulic oil (L)	/	Rando MV32	115	Chevron
Engine oil (L)	Working temperature:-20℃~40℃	15W-40	8	API CJ-4



## Operation Manual of Articulated Boom Mobile Elevating Work Platform

	Working temperature: $-25^{\circ}\text{C} \sim 30^{\circ}\text{C}$	10W-30		
	Working temperature: $-30^{\circ}\text{C} \sim 30^{\circ}\text{C}$	5W-30		
	Working temperature: $-35^{\circ}\text{C} \sim 20^{\circ}\text{C}$	0W-20		
Coolant (L)	/	50% LLC/50% clean soft water	8.5	/
Diesel (L)	The lowest temperature $\geq 4^{\circ}\text{C}$	0 #Diesel	65	EN590 ULSD
	The lowest temperature $\geq -5^{\circ}\text{C}$	-10 #Diesel		
	The lowest temperature $\geq -14^{\circ}\text{C}$	-20 #Diesel		
	The lowest temperature $\geq -29^{\circ}\text{C}$	-35 #Diesel		
Front axle, rear axle (L)	$30^{\circ}\text{C} <$ Minimum temperature	85W/140	9.6×2	API GL-5
	$-10^{\circ}\text{C} <$ Minimum temperature $< 30^{\circ}\text{C}$	85W/90		
	$-30^{\circ}\text{C} <$ Minimum temperature $< -10^{\circ}\text{C}$	80W/90		
	Minimum temperature $< -30^{\circ}\text{C}$	75W		
Gear box (L)	$30^{\circ}\text{C} <$ Minimum temperature	85W/140	0.4	API GL-5
	$-10^{\circ}\text{C} <$ Minimum temperature $< 30^{\circ}\text{C}$	85W/90		
	$-30^{\circ}\text{C} <$ Minimum temperature $< -10^{\circ}\text{C}$	80W/90		
	Minimum temperature $< -30^{\circ}\text{C}$	75W		
Slewing reducer (L)	$30^{\circ}\text{C} <$ Minimum temperature	85W/140	1.3	API GL-5
	$-10^{\circ}\text{C} <$ Minimum temperature $< 30^{\circ}\text{C}$	85W/90		
	$-30^{\circ}\text{C} <$ Minimum temperature $< -10^{\circ}\text{C}$	80W/90		
	Minimum temperature $< -30^{\circ}\text{C}$	75W		
Inner raceway of slewing bearing	/	Lithium base grease 2#	Appropriate amount	/
Surface of slewing	/	Lithium base grease	Appropriate	/



## Operation Manual of Articulated Boom Mobile Elevating Work Platform

gear and slewing bearing		2#	amount	
--------------------------	--	----	--------	--

### 4.8 Scope of work

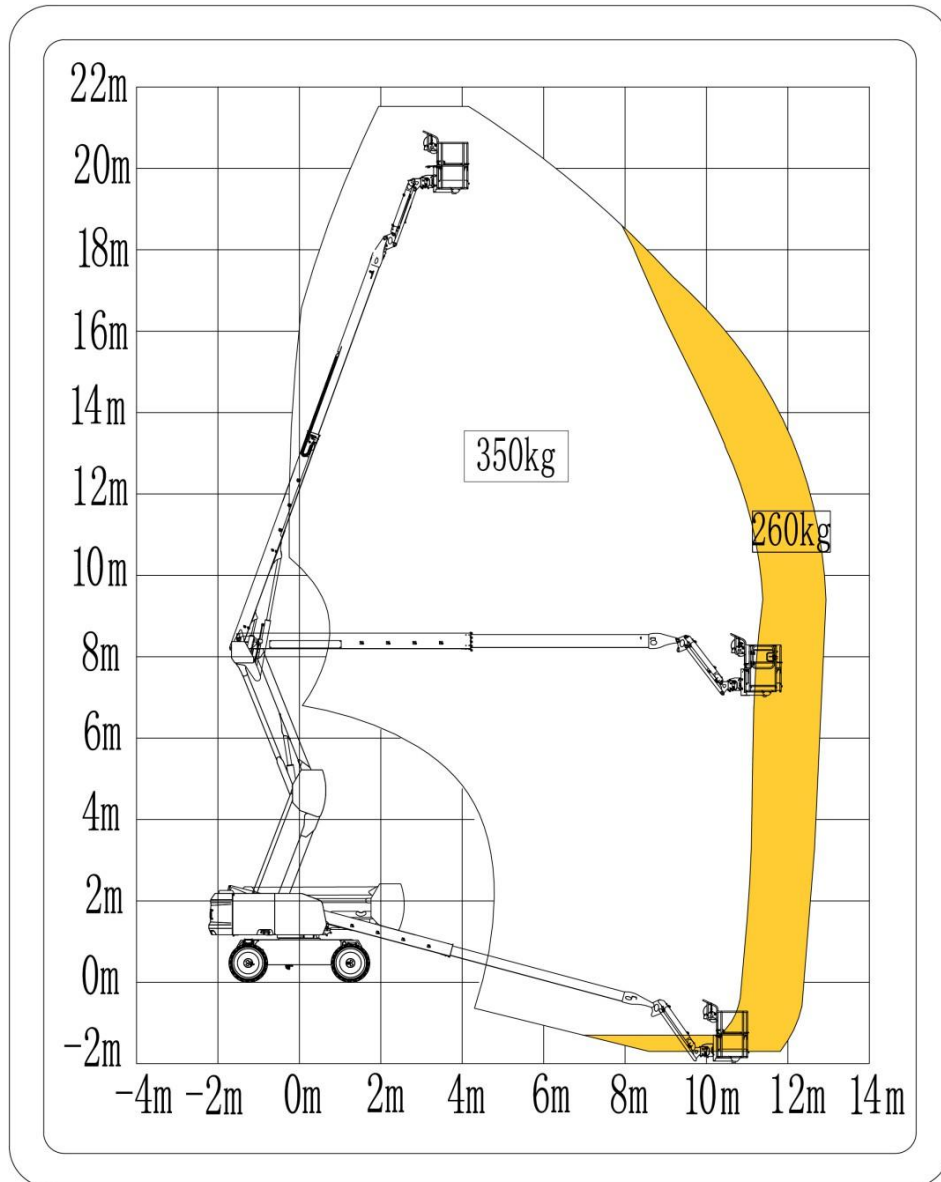

Sequence of operation:

When operating with a ground controller: the machine motion range is automatically controlled according to the load on the platform.

When the platform load is less than 260Kg, AR20J motion range is not restricted.

When the platform load is greater than 260Kg and less than 350Kg, AR20J motion range is restricted.

When operating with the platform controller: the machine motion range is controlled by the load selection button switch of the platform controller.

Turn the dial button switch to 260Kg: the rated load of the machine is 260Kg, and the motion range of AR20J is not restricted.

Turn the dial button switch to 350Kg: the restricted load of the machine is 350Kg, and the motion range



**Operation Manual of Articulated Boom  
Mobile Elevating Work Platform**

---

of AR20J is restricted.



## Operation Manual of Articulated Boom Mobile Elevating Work Platform

### AR20J (A2012J0WNK3CH7000) overall parameters

#### 4.1 Overall performance parameters

Item	Parameters	Item	Parameters	
Rated load (kg)	260	Rotary table slewing time per circle (stowed) (s)	80-110	
	2 people +100 kg	Rotary table slewing time per circle (Extend)( s)	122-155	
Limiting load (kg)	350	Rise time of main boom (s)	50-70	
	3 people +110 kg	Descent time of main boom (s)	50-70	
Overall weight (kg)	9850	Rise time of tower boom (s)	40-60	
Maximum working height (m)	21.58	Descent time of tower boom (s)	40-60	
Maximum platform height (m)	19.58	Boom extension time (s)	30-40	
Maximum horizontal extension (m)	12.37	Boom retraction time (s)	35-45	
Maximum span height (m)	8.19	Jib boom lifting time (s)	25-35	
Minimum turning radius (four wheels) (inner wheels) (m)	1.9	Jib boom lowering time (s)	20-35	
Minimum turning radius (four wheels) (outer wheels) (m)	3.9	Platform slewing time (s)	13-26	
Maximum driving speed (no-load, stowed) (km/h)	5±0.25	Maximum manual force (N)	400	
Maximum driving speed (deployment) (km/h)	0.8±0.05	Maximum allowable wind speed (m/s)	12.5	
Maximum braking distance (no-load, stowed) (m)	1≤S≤1.5	Theoretical maximum climbing ability (no-load, stowed)	45%	
Driving type	Four-wheel drive	Maximum allowable inclination angle of chassis	Along the boom	4°
	Four-wheel steering		Orthogonal to boom	4°
Turntable rotate angle (° )	360	Machine tail swing (mm)	975	
Secondary boom raise angle (° )	/	Jib boom raise angle (° )	120	
Jib boom rotate angle (° )	/	Platform rotate angle (° )	180	

#### 4.2 Main dimensions

Item	Parameters	Item	Parameters
Overall length (mm)	9420	Wheelbase (mm)	2510
Overall width (mm)	2500	Wheel track (mm)	2140
Overall height (mm)	2460	Ground clearance (mm)	400
Dimensions of working platform (L×W) (mm)	2440×900	Tire specification (diameter×width)(mm)	940×350

#### 4.3 Engine system



## Operation Manual of Articulated Boom Mobile Elevating Work Platform

Item	Parameters	Item	Parameters
Model	V2403BM-DI-C T04e	Rated speed (r/min)	2600
Displacement (L)	2.4	Maximum torque (N.m)/speed (r/min)	158.6/1600
Rated power (kW)	36	Emission standard	EU stage IIIA

### 4.4 Drive system

Item		Parameters/Content
Front axle	Speed ratio	21.81: 1
	Brake type	Multi-disc wet braking
Rear axle	Speed ratio	21.81: 1
	Brake type	Multi-disc wet braking

### 4.5 Hydraulic system

Item		Parameters/Content	
Functional system	Type	Open system	
	Pump displacement (ml/r)	20	
	Lifting system	Maximum working pressure (MPa)	23
	Slewing system	Maximum working pressure (MPa)	9
		Motor displacement (ml/r)	80
Steering system	Maximum working pressure (MPa)	15	
Driving system	Type	Closed system	
	Maximum working pressure (MPa)	40	
	Displacement of pump(ml/r)	56	
	Displacement of motor(ml/r)	63	

### 4.6 Electric system

Item		Parameters/Content
Battery	Output voltage (V)	12
	Capacity (Ah)	120
Control system	Voltage (V)	12

### 4.7 Filling volume

Item	Condition	Grade	Capacity	Remarks
Hydraulic oil	/	Rando MV32	115L	Chevron
Engine oil (L)	Working	15W-40	8	API CH-4



## Operation Manual of Articulated Boom Mobile Elevating Work Platform

	temperature:-20℃~40℃			
	Working temperature:-25℃~30℃	10W-30		
	Working temperature:-30℃~30℃	5W-30		
	Working temperature:-35℃~20℃	0W-20		
Coolant (L)	/	50% LLC/50% clean soft water	8.5	/
Diesel (L)	The lowest temperature≥4℃	0 #Diesel	65	EN590 ULSD
	The lowest temperature≥-5℃	-10 #Diesel		
	The lowest temperature≥-14℃	-20 #Diesel		
	The lowest temperature≥-29℃	-35 #Diesel		
Front axle, rear axle	30℃ < Minimum temperature	85W/140	9.6L ×2	API GL-5
	-10℃ < Minimum temperature <30℃	85W/90		
	-30℃ < Minimum temperature <-10℃	80W/90		
	Minimum temperature <-30℃	75W		
Gear box	30℃ < Minimum temperature	85W/140	0.4L	API GL-5
	-10℃ < Minimum temperature <30℃	85W/90		
	-30℃ < Minimum temperature <-10℃	80W/90		
	Minimum temperature <-30℃	75W		
Slewing reducer	30℃ < Minimum temperature	85W/140	1.3L	API GL-5
	-10℃ < Minimum temperature <30℃	85W/90		
	-30℃ < Minimum temperature <-10℃	80W/90		
	Minimum temperature <-30℃	75W		
Inner raceway of slewing bearing	/	Lithium base grease 2#	Appropriate amount	/



**Operation Manual of Articulated Boom  
Mobile Elevating Work Platform**

Surface of slewing gear and slewing bearing	/	Lithium base grease 2#	Appropriate amount	/
---	---	------------------------	--------------------	---



#### 4.8 Scope of work

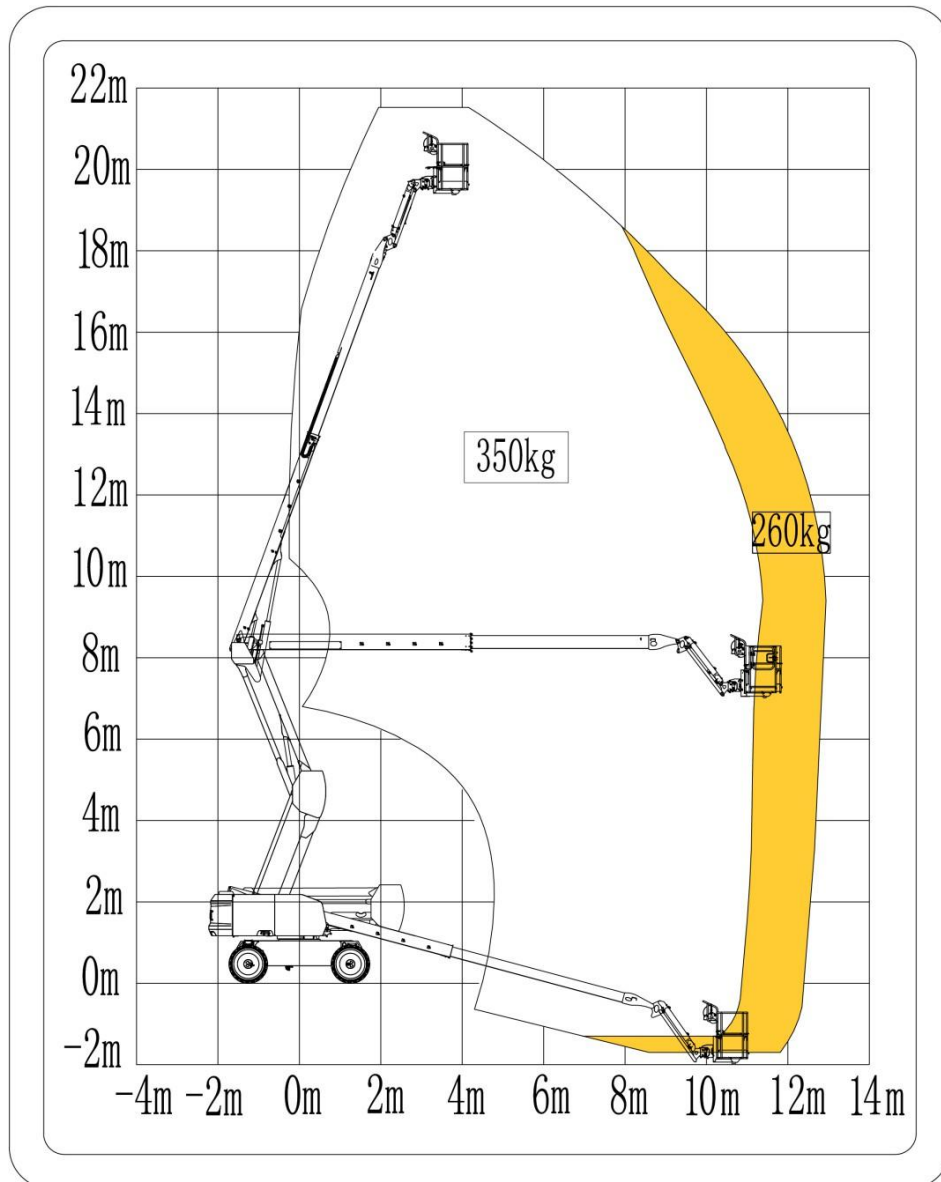

Sequence of operation:

When operating with a ground controller: the machine motion range is automatically controlled according to the load on the platform.

When the platform load is less than 260Kg, AR20J motion range is not restricted.

When the platform load is greater than 260Kg and less than 350Kg, AR20J motion range is restricted.

When operating with the platform controller: the machine motion range is controlled by the load selection button switch of the platform controller.

Turn the dial button switch to 260Kg: the rated load of the machine is 260Kg, and the motion range of AR20J is not restricted.

Turn the dial button switch to 350Kg: the restricted load of the machine is 350Kg, and the motion range of AR20J is restricted.



## Chapter 5 Control Box



**Operation Manual of Articulated Boom  
Mobile Elevating Work Platform**

---



## 5.1 GCU

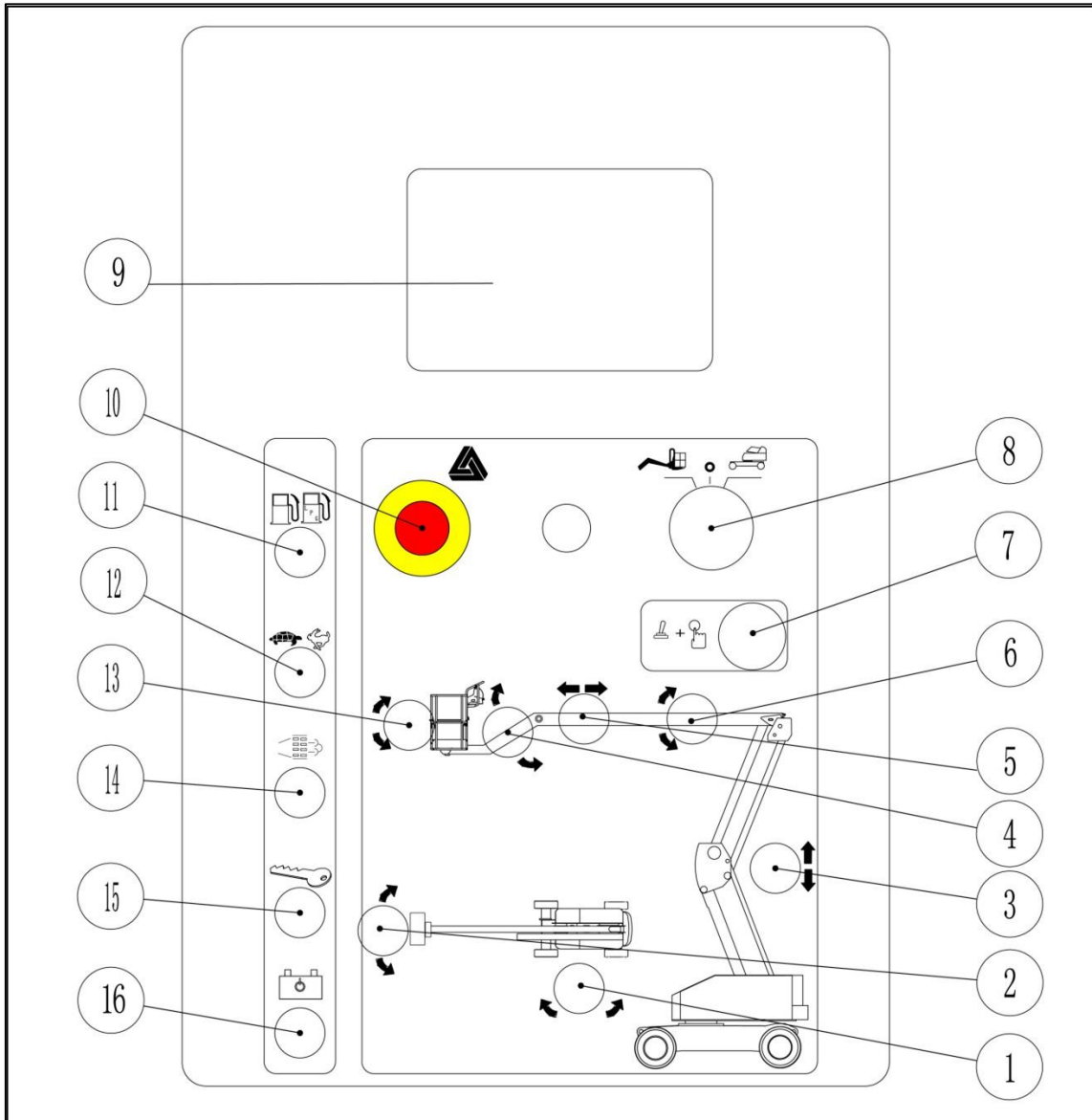

Figure 5-1 GCU panel





No.	Name	No.	Name
1	Rotary table slewing switch	9	Display
2	Platform rotary switch	10	Emergency stop switch
3	Tower boom up/down switch	11	Reserved
4	Jib boom up/down switch	12	Engine speed select switch
5	Boom extension/retraction switch	13	Platform leveling switch
6	Boom up/down switch	14	Manual DPF regeneration switch
7	Function enable button	15	Engine start switch
8	Key switch	16	Emergency power unit switch

Table 5-1 Description of GCU panel functions

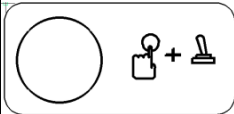

## Operation Manual of Articulated Boom Mobile Elevating Work Platform

Table 5-2 The function description of the button switch of the GCU is shown in the table below:

Item	Button switch	Function description
GCU	Key switch	 <p>Turn the key switch to the platform position, and the PCU will run. Turn the key switch to the OFF position and the machine will be turned off. Turn the key switch to the chassis position. The GCU will run.</p>
	Emergency stop switch	 <p>All functions can be stopped by pushing the red "emergency stop" button inward to the "off" position; Turn the red "emergency stop" button to the on position. The machine can be operated, with the warning lamp flashing.</p>
	Function enabling button	 <p>All boom and platform functions will not run if the the function enabling button is not pressed and held; Press and hold the function enabling button, and activate the switch of each boom and platform function, so that all boom and platform functions can run.</p>
	Engine Start Switch	 <p>Move the engine start switch to one side to start the engine.</p>
	Emergency power unit switch	 <p>If the main power source fails, use the emergency power unit. Activate the required function while keeping the emergency power unit switch on.</p>
		<ol style="list-style-type: none"> <li>1. Turn the key switch to the GCU position.</li> <li>2. Turn the red "Emergency Stop" switch outward to the ON position.</li> <li>3. Start the engine.</li> <li>4. Press and hold the function enabling button.</li> </ol>
	Platform rotary switch	<p>Pull up the platform rotary switch, and the platform will rotate to the left; Pull down the platform rotary switch, and the platform will rotate to the right.</p>
	Rotary table slewing switch	<p>Turn the switch to the right, and the rotary table will rotate to the right; Turn the switch to the left and the rotary table will rotate to the left.</p>
	Boom up/down switch	<p>Pull up the switch, and the boom will rise; Pull down the switch, and the boom will lower. When the boom is lowered, the buzzer shall sound.</p>
	Boom extension/retraction switch	<p>Turn the switch to the right, and the boom will be retracted; turn the switch to the left, and the boom will be extended. The buzzer will sound when the boom extends and retracts to the maximum position.</p>
Tower boom up/down switch	<p>Pull up the switch, and the tower boom will rise; Pull down the switch, and the tower boom will lower.</p>	
Jib boom up/down switch	<p>Pull up the switch, and the jib boom will rise; Pull down the switch and the jib boom will lower.</p>	
Platform leveling switch	<p>Pull the platform leveling switch upward, and the platform level will rise. When the platform leveling switch is pulled down, the platform level will descend.</p>	



## 5.2 PCU

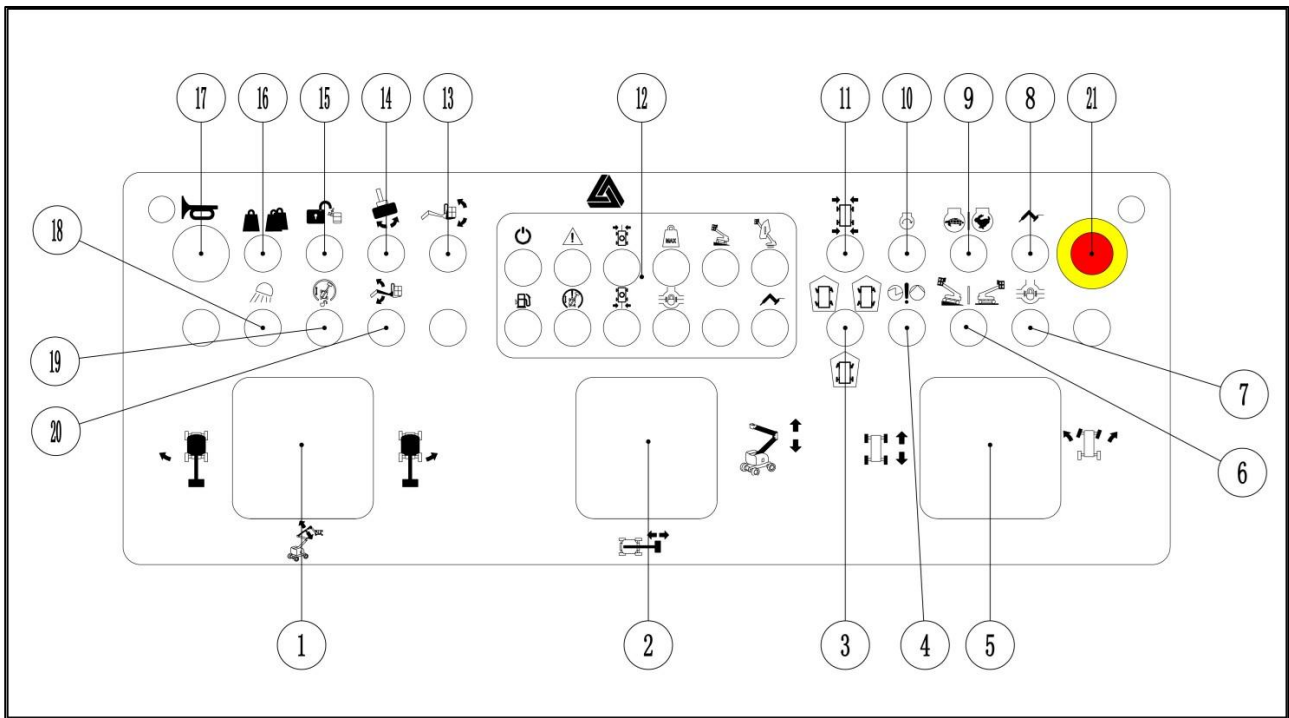

Figure 5-2 PCU panel







No.	Name	No.	Name
1	Boom lifting/lowering and rotary table slewing control handle	12	Indicator lamp
2	Boom extension/retraction and tower boom up/down control handle	13	Platform leveling switch
3	Crab steering/front wheel steering/four-wheel steering	14	Platform rotary switch
4	Emergency power unit	15	Override switch
5	Drive and steering control handle	16	Load selection switch
6	Drive speed select switch	17	Horn button
7	Differential lock	18	Lighting lamp (if equipped)
8	Generator switch	19	Drive enabling switch
9	Engine speed select switch	20	Jib boom up/down switch
10	Engine start switch	21	Emergency stop switch
11	Wheel automatic alignment		

Table 5-3 Name of Each Function of PCU Panel





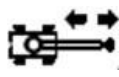
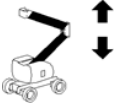



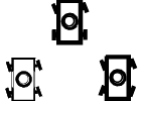
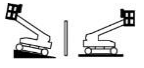

## Operation Manual of Articulated Boom Mobile Elevating Work Platform

Table 5-4 The function description of the button switch of the PCU is as follows:

Item	Button switch	Function description	
PCU	Emergency stop switch		Push the red "emergency stop" button inward to the OFF position to stop all PCU functions. Turn the red "emergency stop" button to the ON position to operate the machine on the PCU.
	Engine Start Switch		Move the engine start switch to one side to start the engine.
	Foot switch		Do not press down the pedal switch, and test each function of the machine. As a result, the machine function should not run. Depress the foot switch to activate the control handle or button switch for each function of the machine. All boom and platform functions shall be run for a full cycle.
	Emergency power unit		If the main power source fails, use the emergency power unit. Press the foot switch and activate the desired function while keeping the emergency power switch on. <b>CAUTION:</b> To save battery power, please test each function in part of a cycle. Result: all boom functions shall operate normally. The drive function shall not work with the emergency power supply.
			1. Turn the key switch to the PCU position. 2. Turn the red "emergency shutdown" button outward to the ON position. 3. Start the engine. 4. Press down the foot switch.
	Boom up/down and rotary table slewing handle		Move the control handle to the right and the rotary table will move to the right. Move the control handle to the left and the rotary table will move to the left.
			Move the control handle up and the boom will rise; Move the control handle down and the boom will lower. When the boom is lowered, the buzzer shall sound; The buzzer will sound when the boom is luffed to the maximum and minimum positions.
	Boom extension/retraction and tower boom up/down control handle		Move the control handle to the right, and the boom will extend; Move the control handle to the left, and the boom will retract.
			Move the control handle up and the tower boom will rise; Move the control handle down and the tower boom will lower.
	Platform leveling switch		Pull the platform leveling switch upward, and the platform level will rise. When the platform leveling switch is pulled down, the platform level will descend.
Platform rotary switch		Turn the platform rotary switch to the right, and the platform will rotate to the right. Move the switch of the platform to the left, and the platform will rotate to the left.	

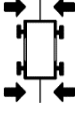



## Operation Manual of Articulated Boom Mobile Elevating Work Platform

Jib boom lifting/lowering switch		<p>Pull up the switch and the jib boom will rise; Pull down the switch and the jib boom will descend.</p>
Steering mode selection switch		<p>When the switch is in the middle position, it is in the two-wheel steering mode, and only the front wheels are steering;</p> <p>When the switch is turned to the left, the rear wheels turn in the same direction as the front wheels;</p> <p>When the switch is turned to the right, the rear wheel and the front wheel turn in the opposite direction.</p>
Drive speed selection switch		<p>The machine is located at sign on the slope: To acquire more driving torque, select the slope sign on the inclined or rough ground.</p> <p>The machine is located at the sign on the horizontal plane: For operation of maximum driving speed.</p>
Differential lock		<p>Toggle the differential lock switch and keep the differential lock continuously activated to increase the traction of the wheels on the rear axle. The differential light comes on after toggle the differential lock switch.</p>
Generator switch		<p>Move the generator switch to activate or turn off the generator.</p>
Engine Idle Speed Selector Switch		<p>Pull the idle speed selector switch to the turtle position, the engine starts the low idle speed; Pull the idle speed selector switch to the rabbit position, step on the foot switch and turn the handle, then the engine starts the high idle speed. After releasing the handle, the engine enters the low idle speed.</p>
Wheel automatic alignment		<p>Turn the wheel automatic alignment switch to the left, the wheels will be automatically aligned, and the rear and front wheel alignment indicator lamps will light up, indicating that the wheels have been aligned.</p>
Load selection switch		<p>Turn the switch to the left to select the rated load mode (the range of motion of the boom is not limited) or turn the switch to the right to choose the limited load mode (the range of motion of the boom is limited). For details about the range of motion of the boom, see section 4.8.</p>
Override switch		<p>When the platform safety protection system is activated, press the override switch, and the vehicle functions can operate normally.</p>
Drive enable switch		<p>When the rotary table rotates to a certain angle, the drive function cannot operate, and the drive enable indicator lamp alarms. Turn the drive enable switch to one side and release it, slowly move the driving function control handle. Result: The driving function shall operate.</p>

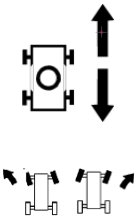

## Operation Manual of Articulated Boom Mobile Elevating Work Platform

	Drive/steering control handle		<p>Move the control handle upward, and the machine will drive forward; Move the control handle downward and the machine will drive backward.</p> <p>Press the left side of the thumb rocker. The front axle turns to the left, and the rear axle turns according to the four-wheel steering mode;</p> <p>Press the right side of the thumb rocker. The front axle turns to the right, and the rear axle turns according to the four-wheel steering mode.</p>
	Lighting lamp		Flip the switch to turn the light on/off.

The indicator lamp function description of the display panel is described in the following table:











	System fault alarm		Limited range of motion
	Platform overload alarm		Machine tilt alarm
	Driver Enable Indication		Generator is in use
	Minimum fuel level alarm		Indication after differential lock enabled
	Rear wheel alignment indication		Front wheel alignment indication

Table 5-5 Functional Description of LED Display Panel



## 5.3 Control Logic (SPD)

After the SPD is triggered, use the platform controls to operate the machine without using the override function, and all functions cannot operate; use the platform controls to operate the machine with using the override function, and the boom can be lowered and retracted but cannot be raised or extended, the turntable cannot be swung, the jib can be lowered but cannot be raised, the platform cannot be rotated or leveled, and the complete machine can travel and steer. After the SPD is triggered, use the ground controls to operate the machine, and all functions except for the traveling and steering functions can operate. The control logic is shown in the table below.

### SPD Activated

Position	Platform	Platform	Ground
Power	Main power	Main power	Main power
Status	NO override	Override	NO override
Primary Up Secondary Up	x	x	√
Primary Down Secondary Down	x	√	√
Primary Extend Secondary Extend	x	x	√
Primary Retract Secondary Retract	x	√	√
Turntable Swing	x	x	√
Jib Up	x	x	√
Jib Down	x	√	√
Platform Rotate	x	x	√
Platform Level Up	x	x	√
Platform Level down	x	x	√
Drive	x	√	—
Steer	x	√	—



**Operation Manual of Articulated Boom  
Mobile Elevating Work Platform**

---



## Chapter 6 Pre-operation Inspection



**Operation Manual of Articulated Boom  
Mobile Elevating Work Platform**

---



## 6.1 Before Performing This Operation, Ensure that

- 1) Equipped with PFPE, such as helmet, safety belt, safety shoes, goggles, protective gloves, and in good physical condition.
- 2) You have understood and implemented the rules for safe operation of machines in this Operation Manual.
- 3) Avoid dangerous situations. Know and understand the safety rules before proceeding to the next step.
- 4) Check the workplace, please refer to the workplace inspection section of this manual.
- 5) Please read, understand and comply with all applicable government laws and regulations.
- 6) You are properly trained and qualified to operate the machine safely.
- 7) Only qualified maintenance technician can repair the machine according to the regulations of our company.

## 6.2 Basic Principles

- 1) Inspection and routine maintenance before performing operations are the responsibility of the operator.
- 2) The pre-operation inspection is a very intuitive inspection process, which is performed by the operator before each change of work. The purpose of the inspection is to find out whether there is an obvious problem with the machine before the operator performs the functional test.
- 3) Pre-operation checks can also be used to determine whether routine maintenance procedures are required. The operator can only perform routine maintenance items specified in this manual.
- 4) Please refer to the list on the next page and check each item.
- 5) If damage is found or any unlicensed change from the factory condition, the machine shall be marked and out of service.

- 6) Only qualified maintenance technician can repair the machine. After the repair, the operator shall perform another pre-operation check before continuing the functional test.
- 7) According to the manufacturer's regulations and the requirements listed in the manual, the scheduled maintenance inspection shall be carried out by the qualified maintenance technician.

## 6.3 Pre-operation Inspection

- 1) Ensure that the manual is complete, easy to read, and kept in the file box of the platform. If the manual needs to be replaced, please contact LGMG service personnel.
- 2) Ensure that all labels are clear, legible and properly located. Please refer to the "label" section. If you need to replace the labels, please contact LGMG service personnel.
- 3) Check whether the ball valve at the oil suction port at the bottom of the hydraulic tank is open or whether the oil suction filter switch is open (self-sealing filter). It must be kept open unless there are special circumstances, and it must be open when the machine is in motion. If the valve or switch is not opened when the machine is in motion, the oil pump will be completely damaged.
- 4) Please refer to the "Maintenance" section to check whether the hydraulic oil is leaking and whether the oil level is appropriate.
- 5) Check whether the battery wiring is secure.
- 6) Check the following components for damage, improper installation, loose or missing part and unauthorized alteration:
  - Electrical plugs, wiring and cables
  - PCU, GCU
  - Tilt sensors, angle sensors, weighing sensors
  - Displays, alarm indicator lamps, flashing lights, horns, buzzers, drive-enabling limit switches
  - Valve block, hosepipe, hydraulic joint, cylinder, slewing motor and reducer
  - Hydraulic tank



## Operation Manual of Articulated Boom Mobile Elevating Work Platform

---

- Wear-resistant pad, tire, slewing bearing
  - Nuts, bolts and other fasteners
  - Platform entrance lifting cross bar
  - Platform safety guard
  - Drive axle and pump
  - Engine and parts
- 7) Check the entire machine to find:
- Cracks in weld or structural parts
  - Dent or damage to the machine
  - Serious rust, corrosion or oxidation
  - Ensure that all structural parts and other key components are complete and all relevant fastener and pin are in the correct position and tightened
  - After completing the inspection, make sure that the hood is in proper position and locked.

components and other critical components of the SPD are intact, and that all relevant fasteners and pins are in correct positions and tightened.

- 3) Check to ensure that there are no foreign objects in the SPD grooves.
- 4) Check that the SPD's function is normal, and the machine can be operated normally via the verification procedures.
- 5) If any unauthorized changes from the factory delivered condition or damages are found, the machine must be tagged out and removed from use.

### 6.4 Pre-operation Inspection of Safety Protection Devices (SPD)

- 1) Check the following components for damage, improper installation, loose or missing parts, and unauthorized changes:
- Electrical plugs, wiring and cables
  - Display screen, alarm indicator light, strobes, horn, buzzer
  - Nuts, bolts and other fasteners
  - Platform entrance lever
  - Platform safety protection device
- 2) Check to ensure that all structural



## **Chapter 7 Workplace Inspection**



**Operation Manual of Articulated Boom  
Mobile Elevating Work Platform**

---



## 7.1 No Operation Is Allowed Unless

You have understood and practiced the principles about safe operation of the vehicle in this manual.

- 1) Avoid dangerous situations.
- 2) Always perform a pre-operation inspection.
- 3) Check the workplace. You should understand pre-operation inspection before proceeding with the next step.
- 4) Always perform a pre-use functional test.
- 5) Use the vehicle only for its intended purpose.

## 7.2 Basic Principles

- 1) Workplace inspection helps the operator to determine whether the workplace can ensure the safe operation of the machine. The operator shall first perform this work before moving the machine to the workplace.
- 2) It is the operator's responsibility to understand and remember hazardous matters in the workplace, which can be noticed and avoided when moving, installing and operating the equipment.

## 7.3 Workplace Inspection

Pay attention to and avoid the following dangerous situations:

- Steep slope or cave
- Protrusions, ground barriers or debris
- Inclined surface
- Unfirm or smooth surface
- Air obstacles and high voltage wires
- Surface support insufficient to withstand the

full load force exerted by the machine

- The instantaneous wind speed exceeds 12.5 m/s
- Use ambient temperature and humidity beyond the required temperature and humidity requirements
- Unauthorized personnel appear
- Other possible unsafe situations



**Operation Manual of Articulated Boom  
Mobile Elevating Work Platform**

---



## Chapter 8 Functional Testing



**Operation Manual of Articulated Boom  
Mobile Elevating Work Platform**

---



## 8.1 Basic Principles

- 1) You have understood and implemented the rules for safe operation of machines in this Operation Manual.
- 2) PFPE, such as helmets, seat belts, safety shoes, goggles, etc., have been equipped according to site needs and are in good physical condition.
- 3) Select a solid, level and barrier-free test area.
- 4) Avoid dangerous situations. Know and understand the safety rules before proceeding to the next step.
- 5) Functional testing is used to detect faults before starting to use the machine.
- 6) The operator must test all functions of the machine according to the procedure instructions.
- 7) Do not use the faulty machine. If a fault is found, the machine must be marked and stopped to use.
- 8) Only qualified maintenance technician are allowed to repair the machine according to our company's regulations.
- 9) After the repair, the operator must perform the pre-operation inspection and function test again before starting to use the machine.

## 8.2 At GCU

Turn the key switch to the GCU position.

Turn the red "emergency stop" button out to the "on" position, and the alarm lamp starts to flash.

Refer to the "Operation Instructions" section to start the engine.

- 1) Test emergency shutdown
  - Push the ground red "Emergency Stop" button inward to the "OFF" position.

Result: The engine is off and none of the functions work.

- Turn the red emergency stop button out to the "ON" position.
- 2) Test machine function

- Do not press and hold the function enable button switch. Try to enable each boom and platform function button switch.

Result: All boom and platform functions fail.

- Press and hold the function activation button switch, and activate each boom and platform function button switch.

Result: all the functions of boom and platform run for a full cycle. The buzzer sounds when the main boom is descending.

- 3) Test the emergency power unit



**CAUTION: Perform this step**

**when the engine is off. To save battery power, please test each function in half of a cycle.**

- Turn the red emergency stop button to the OFF position.
- Turn the key switch to the ground control position and turn the red emergency stop button to the ON position.
- Turn the emergency power unit switch and activate each boom function switch at the same time.

Result: all the boom functions shall be operational.

- 4) Inspect the automatic leveling of the work platform

- Start the engine from the ground.
- Press and hold the function enable switch and adjust the operation platform to the horizontal position with the platform leveling button.
- Raising and lowering the boom through a full cycle.

Result: the platform is always horizontal.

## 8.3 On the Platform

Turn the key switch to the PCU.

Turn the red "Emergency Stop" button out to the "On" position.

Start the engine.

- 1) Test emergency shutdown



## Operation Manual of Articulated Boom Mobile Elevating Work Platform

- Push the platform red "Emergency Shutdown" button to the "OFF" position.

Result: The engine is off and no function can be operated.

- Turn the platform red "Emergency Stop" button out to the "On" position.

### 2) Test horn

- Press the horn button.

Result: the horn sounds.

### 3) Test foot switch

- Push the red "emergency stop" button of the platform to the off position.
- Rotate the red "emergency stop" button to the on position and do not start the engine.
- Press down the foot switch and try to start the engine by pulling the start toggle switch to upper side.

Result: The engine does not start.

- Do not press the foot switch and restart the engine.

Result: The engine start.

- Do not press the foot switch and test the machine's functions.

Result: None of the functions are running.

### 4) Test machine function

- Stepping on the foot switch.
- Activate each function control handle or button switch of the machine.

Result: All boom/platform actions work normally within one complete cycle.

### 5) Test the emergency power unit



**Caution: Perform this step when the engine is off. In order to save battery energy, test each function in half a cycle.**

- Turn the key switch to the PCU.

- Turn the red emergency stop button to the "on" position on the work platform control and press the foot switch.

- Press the emergency power unit switch to the "on" position and turn on each function control handle or toggle switch.

Result: All boom and steering functions work normally and drive functions do not work.

### 6) Test steering

- The machine is in the stowed state.
- Stepping on the foot switch.
- Press the left side of the thumb rocker switch at the top of the drive control handle.

Result: the front wheel rotates in the direction indicated by the blue arrow on the drive chassis, the rear wheels depend on the steering mode.

- Press the right side of the thumb rocker switch on the top of the drive control handle.

Result: the front wheel rotates in the direction indicated by the yellow arrow on the drive chassis, the rear wheels depend on the steering mode.

### 7) Test drive and brake functions

- The machine is in the stowed state.
- Stepping on the foot switch.
- Slowly move the drive control handle in the direction indicated by the blue arrow on the control panel until the machine starts to move, and then restore the handle to the center position.

Result: The machine should move in the direction indicated by the blue arrow on the drive chassis and then stop suddenly.

- Slowly move the drive control handle in the direction indicated by the yellow arrow on the control panel until the machine starts to move, and then restore the handle to the center position.

Result: the machine should move in the direction indicated by the yellow arrow on the drive chassis and then stop suddenly.



**CAUTION: The brake must be**

**able to stop the machine on any slope it can climb on.**

8) Test tilt sensor

- Stepping on the foot switch.
- Raise the boom 5° or extend it 0.6 m, and drive the machine to a slope inclining 4° in the boom direction.

Result: The machine tilt indicator lamp is on, the buzzer sounds, and some actions are restricted.

- Raise the boom 5° or extend it 0.6 m, and drive the machine to a slope inclining 4° in the direction orthogonal to the boom.

Result: The machine tilt indicator lamp is on, the buzzer sounds, and some actions are restricted.

- Drive the machine up to the slope of the maximum allowable tilt angle of the chassis.
- Start all boom functions successively.
- Operate the handle to activate the rotary table slewing function.

Result: The boom cannot be raised upward after it is raised upward to the position 5° above the horizontal level; The boom cannot continue to extend after being extended by 0.6 m, and the functions such as boom extension, boom luffing up, rotary table slewing, leveling, steering, and walking are limited. Other boom functions can be used normally.



**CAUTION: If the rotary table**

**inclines 4° in the boom direction or 4° in the direction vertical to the boom (the maximum allowable inclination angle of the chassis), the boom can be raised more than 5° above the horizontal plane or extended more than 0.6 m, and the machine should be marked immediately and stopped.**

9) Test floating cylinder

- The machine is in the stowed state.
- Stepping on the foot switch.

- Drive the right steering wheel to a 10 cm high barrier or curb.

Result: The remaining three tires are in close contact with the ground.

- Drive the left steering wheel to a 10 cm high barrier or curb.

Result: The remaining three tires are in close contact with the ground.

- Drive the left rear wheel to a 10 cm high obstacle or curb.

Result: The remaining three tires are in close contact with the ground.

- Drive the right rear wheel to a 10 cm high obstacle or curb.

Result: The remaining three tires are in close contact with the ground.

10) Test drive enable system



Figure 8-1 Drive Enable

- The machine is in the stowed state.
- Stepping on the foot switch.
- Turn the rotary table until the boom is at a certain angle, as shown in Figure 8-1.

Result: At any position of the boom within the range shown in the figure, the drive enable indicator lamp should be flash.

- Move the drive control lever away from the center position.

Result: the drive function does not work.

- Turn the drive enable button switch to the upper side and release it, and meanwhile slowly move the drive control lever away from the center position.

Result: The drive function runs.



**CAUTION: When using the drive enable system, the machine may travel in the opposite direction of travel and**



steering control handle movement. Use the color scale direction arrow on the drive chassis to determine the direction of movement.

11) Test limited drive speed

- Stepping on the foot switch.
- Raise the boom 5° (with the boom fully retracted).
- Slowly move the drive control handle to the full drive position.

Result: the maximum drive speed possible does not exceed 0.8 Km/h in the boom lifting state.

- Lower the boom to the retracted state.
- Extend the boom about 0.6 m.
- Slowly move the drive control handle to the full drive position.

Result: the maximum drive speed that the boom can reach in the extended state shall not exceed 0.8 Km/h.



**CAUTION: If the driving speed of the boom when it is raised or extended exceeds 0.8 Km/h, the machine shall be marked and stopped immediately.**

12) Platform overload test

- Load the platform with heavy objects exceeding the limited load.

Result: the indicator lamp is on, the buzzer sounds, and the machine cannot be operated.

- Remove the load on the platform until the indicator lamp goes out.

Result: the machine can be operated.

13) Test driver/boom function

- Stepping on the foot switch.
- Move the drive control lever out of the center position and activate a boom function handle or button switch.

Result: Boom functions do not work. The machine will move in the direction indicated on the control panel.

## 8.4 Verification Procedures for Safety Protection Devices (SPD)

1) After the machine is powered on, press down the foot switch, operate the joystick, and disengage the safety rod from the proximity switch.

✓ Result: The strobes should flash, the horn should sound intermittently and then keep sound, and no functions should operate.

2) Release the foot switch, restore the safety rod, press down the foot switch, and operate the joystick.

✓ Result: The strobes should be off, the horn should stop, and all functions should operate normally.



## **Chapter 9 Operating Instructions**



**Operation Manual of Articulated Boom  
Mobile Elevating Work Platform**

---



## 9.1 No Operation is Allowed Unless

You have understood and practiced the principles about safe operation of the machine in this manual.

- 1) Avoid dangerous situations.
- 2) Always perform a pre-operation inspection.
- 3) Check the workplace.
- 4) Always perform a pre-use functional test.
- 5) Use the machine only for its intended purpose.

## 9.2 Basic Principles

- 1) This machine is a high-altitude working equipment equipped with a working platform on the articulated arm mechanism. This machine can be used to load workers and their personal tools to a certain height from the ground, and can also be used to reach a certain working area above the machine or equipment.
- 2) The operating instructions section provides specific instructions for various aspects of machine operation. It is the responsibility of the operator to follow all safety rules and instructions on the Operation Manual.
- 3) It is not safe or even dangerous to use this machine for other purposes except for lifting personnel and their tools and materials to air workplaces.



**WARNING: This machine is strictly prohibited from carrying goods or being used as a crane.**

- 4) Only trained and authorized personnel can operate this machine. If more than one operator uses the same machine at different time period during the same work shift, they must all be qualified operators and comply with all safety regulations and instructions in the operation manual. This means that each new operator should carry out pre-operation inspection, functional test and workplace inspection before using the

## 9.3 Starting the Engine

- 1) From the ground control station, turn the key switch to the required position.
- 2) Ensure red "Emergency Shutdown" buttons on the lower control box and the upper control box are pulled to the ON position.
- 3) During startup at low temperature, the engine can be automatically preheated at low temperatures when the whole vehicle is powered on.
- 4) If the primary preheating cannot meet the requirements, press the emergency stop switch of ground control unit and then pull it out, and then perform the preheating operation again.
- 5) Turn the engine startup switch to one side for 2s to 3s. If the engine fails to start or starts up and then stalls immediately, disenable the startup switch for 3s.
- 6) If the engine fails to start 15s, diagnose the reason and repair the fault. Wait for 60s before trying to restart the engine.
- 7) Before operation, the engine shall be idled for 5 minutes to ensure it sufficiently lubricated in case of hydraulic system damage.
- 8) At temperatures lower than  $-18\text{ }^{\circ}\text{C}$ , a boosting battery may be used to try and start the engine.



**CAUTION: Upon the normal running of the engine, do not start up again.**

## 9.4 Emergency Shutdown

- 1) Push the red emergency stop button of the ground or platform controller to the OFF position to stop all functions.
- 2) Repair any function that operates when either red emergency stop switch is pushed in.



## Operation Manual of Articulated Boom Mobile Elevating Work Platform

- 3) Selecting and operating the GCU will interrupt the platform red "emergency stop" button function.

### 9.5 Emergency Power

- 1) If the primary power source fails, use the emergency power.
- 2) Turn the key switch to the ground control position or the platform control position.
- 3) Pull out the red "Emergency Stop" button to the "On" position.
- 4) Activate the required function while keeping the emergency power unit switch on.
- 5) When using emergency power on the platform, you should step on the foot switch.
- 6) The drive function cannot be used when the emergency power is used.
- 7) The single continuous use time of emergency power shall not exceed 7.5 minutes.

### 9.6 Operation on the Ground

Turn the key switch to the GCU position.

Turn the red "Emergency Stop" button to the "On" position.

Start up the engine.

- 1) Adjust the platform position
  - Press and hold the function enabling button.
  - Move the appropriate button switch according to the mark on the control panel to adjust the platform to the appropriate position. Driving and steering functions are not available on the ground.

### 9.7 Operation on the Platform

Turn the key switch to the PCU position.

Turn the red emergency stop button on the ground and platform out to the "on" position.

Start up the engine.



**Do not step down on the pedal**

### switch when starting up the engine.

- 1) Adjust the platform position
  - Stepping on the foot switch.
  - Slowly move the appropriate button switch and control handle as marked on the control panel to adjust the platform to the appropriate position.
- 2) Steering

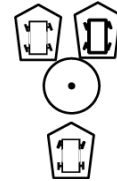

- Select the appropriate steering mode through the steering method selection switch.
- Push down the foot switch and turn the steering wheel by the thumb rocker button at the top of the drive control handle.
- When the button is in the middle, it is in the two wheel steering mode, and only the front wheels is steering. Pull the thumb button to the left, and the front wheel turns in the direction indicated by the blue arrow; Pull the thumb button to the right, and the front wheel turns in the direction indicated by the yellow arrow.
- When the button is turned to the left, it is in the crab steering mode. Pull the thumb button switch and the rear wheel turns in the same direction as the front wheel.
- When the button is turned to the right, it is the four-wheel steering mode. Pull the thumb button switch and the rear wheel turns in the opposite direction to the front wheel.



**CAUTION: Use the color-coded direction arrows on the PCU and the drive chassis to determine the wheel steering direction.**

- 3) Drive
  - Stepping on the foot switch.
  - Increase speed: slowly move the drive control handle to make it deviate from the



## Operation Manual of Articulated Boom Mobile Elevating Work Platform

center position.

- Reduce speed: slowly move the drive controller handle so that it points to the center position.
- Stop: Return the drive control lever to the center position or release the foot switch.
- When the boom is raised to a certain angle, the machine movement speed is limited.



**CAUTION: Use the color-coded direction arrows on the PCU and the drive chassis to determine the machine drive direction.**

#### 4) Driving on a slope

- Determine the uphill, downhill and side slope ratings of the machine.

Maximum slope rating:



Platform downhill (climbing ability): 45% (24 °);



Maximum slope rating, platform uphill: 30% (17 °);



Maximum side slope rating: 25% (14 °)



**CAUTION: Slope rating is limited by ground condition and traction. The term climbing capability is only used in platform downhill.**

- Make sure that the boom is located between the rear axle tires, and the boom is lowered below the horizontal plane and retracted. When the rotary table inclines more than 4° along the boom, at this time,

the drive function and boom function are not limited.

- When going uphill, move the speed button to the climbing position.



**CAUTION: When the boom inclines 5° above the horizontal plane, the drive function will be limited. In this case, the boom should be lowered below the horizontal position.**

- Determine the slope

Measure the bevel with a digital inclinometer or follow the steps below for measurement.

- ✓ Tools required: woodworking ruler, straight wood block (the length is at least 1 m), tape measure and other tools.
- ✓ Place the wood block on the bevel, at the end of the downhill, place the woodworking ruler on the upper edge of the wood block, and lift the end of the wood block until it is level.
- ✓ Keep the wood block horizontal and measure the vertical height from the bottom of the wood block to the ground.
- ✓ Height divided by the length of the wood block (stroke), for example:

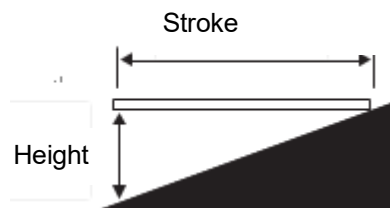

Stroke=3.6 m, raised height=0.3 m

$0.3 \div 3.6 = 0.083 = 8.3\%$



**CAUTION: If the slope exceeds the maximum uphill, downhill or side slope rating, the machine must be lifted or transported up and down along the slope. Please refer to the "Transportation and Lifting" section.**

#### 5) Drive Enable

- The drive enable indicator lamp flashes to



## Operation Manual of Articulated Boom Mobile Elevating Work Platform

indicate that the boom has moved beyond the rear axle tire, the drive is not enabled, and the drive function is limited.

- To drive, pull the drive enable switch upwards and release it, slowly move the drive control handle out of center position.



**NOTE :That the machine may move in the opposite direction to the drive and steering control handles. To stop the drive, release the handle or foot switch.**

### 6) Selection of drive speed

- The machine is located at sign on the slope: To acquire more driving torque, select the slope sign on the inclined or rough ground.
- The machine is located at the sign on the horizontal plane: For operation of maximum driving speed.
- When the vehicle goes downhill, please operate within the low speed range.

### 7) Selection of engine idle speed

- Select engine idle speed with the sign on the control panel.
- In the case of failure to stepdown of foot switch or toggling of handle, the engine will keep idle speed at the lowest revolution.
- Turtle sign: Step down on the foot switch to activate low idle speed.
- Rabbit sign: Step down on the foot switch to activate high idle speed.

### 8) Differential lock



When the wheels are slipping, the differential lock can be used to lock the differential, thus improving the passability of the vehicle.

The differential lock can be activated and closed only when the vehicle is in a stopped state, or is driven straight at a low speed (equivalent to the speed of a person in walking).

Differential lock enable: toggle and hold the differential lock button. At this time, the differential lock indicator lamp lights up.

Differential lock closed: reset the differential lock button. At this time, the differential lock indicator lamp goes out.

### 9) Wheel automatic alignment

Turn the wheel automatic alignment switch to the left, the wheels will be automatically aligned, and the rear and front wheel alignment indicator lamps will light up, indicating that the wheels have been aligned.

## 9.8 Platform Overload

The platform overload indicator lamp is on and the buzzer alarms, indicating that the platform is overloaded. Remove the load from the platform until the indicator lamp goes out.

## 9.9 Machine Not Level

If the tilt alarm sounds when the platform is lifted (the boom inclines more than 5° above the horizontal plane or the boom extends more than 0.6 m), the Machine not level indicator lamp will come on and the drive function will not be available in both directions. Determine the status of the boom on the slope, which is shown as follows. Before moving the machine to a solid, level ground, follow the steps below to lower the boom. Do not rotate the boom before lowering it.

If the tilt alarm sounds when the platform goes uphill:

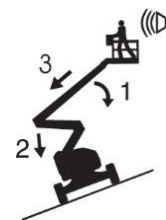

1. Lower the primary boom.
2. Lower the secondary boom.
3. Retract the primary boom.

If the tilt alarm sounds when the platform goes downhill:

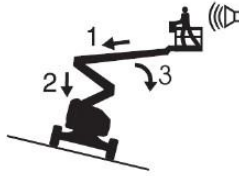

1. Retract the primary boom.
2. Lower the secondary boom.
3. Lower the primary boom.

## 9.10 Function of Safety

### Protection Devices (SPD)

When the safety rod is activated and disengages, the SPD's function will be triggered and all ongoing motions will be stopped. At that time, the blue strobes flash. If the operator presses down the foot switch and attempts to operate the machine, the horn will sound an alarm and no functions will operate. Only when the operator conducts the emergency operation or presses and holds the reset switch, the functions will operate.

The reset switch is on the right of the platform control box, or on the platform box panel depending on the machine models.



Figure-SPD Activated State



Figure-The Strobe Flashes Blue



Figure-Reset Switch 1

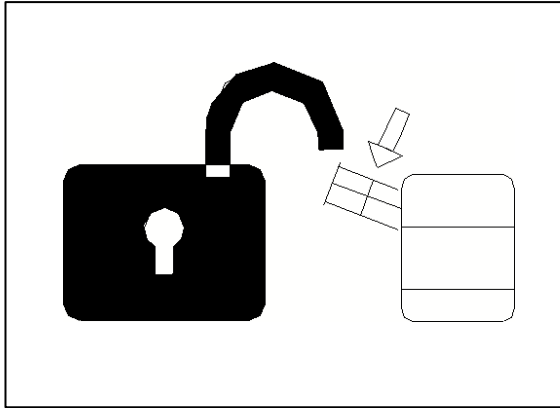

Figure-Reset Switch 2

After the machine is powered on, disengage the safety rod from the proximity switch, and the strobes will flash. Press down the foot switch and the horn will sound immediately. With the foot switch pressed down and being held, press and hold the reset button, operate the joystick, and all functions of the machine will operate normally.

## 9.11 DPF Regeneration (If Equipped)

DPF is designed to reduce environmental pollution and harm to human health by filtering particulate matter from engine exhaust gas.

Automatic DPF regeneration: DPF automatically removes particulate matter accumulation in it.

Manual regeneration: If the machine is free of any engine and system fault and alarm, in the

stowed position and motionless, and the DPF alarm indicator light of GCU is on, manual regeneration will be required.



**Notice: During manual DPF regeneration, there is more exhaust gas, which is hotter. Check the surrounding areas and ensure there is no flammable material and the ventilation is good.**



**Notice: If a manual regeneration request is ignored, smoke in the DPF may reach the extreme level. The filter will be damaged permanently and shall be replaced by qualified technical maintenance personnel.**



**Notice: On an engine equipped with the DPF, partial fuel may be mixed with the engine oil during the regeneration process. Therefore, the engine oil may be diluted and the engine oil may be increased. If the engine oil exceeds the upper limit of the level gauge, the engine oil is diluted too much, leading to a fault. In this condition, please replace the engine oil immediately. If the DPF regeneration interval is 5 hours or shorter, please replace the engine oil.**

**Notice: Please check the engine and place it at a horizontal position. If it is placed on an inclined surface, the oil capacity cannot be**



measured.

- 1) Pull out the Emergency Stop switch and turn the key switch to ground control.



- 2) Press the button indicated in the picture to go into the regeneration system screen.



- 3) Start and idle the engine until coolant temperature exceeds 60°C.



- 4) Move the DPF regeneration toggle switch and the engine will slow down to 1100r/min.

Move the DPF regeneration toggle switch again and the engine will slowly speed up to 2200r/min.

- 5) Wait for the engine to automatically complete DPF regeneration.

### Automatic regeneration inhibition



**Danger: Auto-regeneration shall be prohibited in some working sites.**

- 1) Pull out the Emergency Stop switch and turn the key switch to ground control.



- 2) Press the button indicated in the figure to go into the regeneration system screen.



- 3) Press the "Confirm" button to enter the PDF regeneration initiate/inhibit function screen.



- 4) Select the PDF regeneration initiate/inhibit function as appropriate and press the "Confirm" button.



**Notice: If automatic DPF regeneration is inhibited over a prolonged period of time and manual DPF regeneration is ignored, smoke in the DPF may reach the extreme level. The filter will be damaged permanently and shall be replaced by qualified technical maintenance personnel.**

## 9.12 Machine Safety System Override (MSSO)

Machine Safety System Override function (use auxiliary power or press the platform anti-collision bypass button) can only be used when the safety limit is activated so that the operator can maintain its work in such a situation.

Note: once the MSSO is activated, a yellow icon will be displayed on the screen as shown in the picture listed below. To remove the icon, you need to turn to LGMG service personnel for help.



## 9.13 System Failure

The buzzer alarms and the system fault

indicator lamp illuminates to indicate a control system fault. The LCD screen will display the corresponding fault code, and the machine will turn off the corresponding function, as shown in Table 9-1.

When the system indicator lamp is on, please follow these steps:

- 1) Lower and indent the boom.
- 2) Move the machine to the storage position, mark the machine and stop using it.
- 3) Personnel with relevant qualifications shall carry out maintenance, remove the fault and conduct a comprehensive inspection before re-use.



## Operation Manual of Articulated Boom Mobile Elevating Work Platform

4) The system fault code is shown in the following table:

Error code	Description
1	Controller output power supply 1 open circuit
2	Controller output power supply 2 open circuit
3	Controller output power supply 3, 4 open circuit
4	The CAN bus of the expansion module of the platform electric box is disconnected
7	Turntable tilt sensor failure
8	Load cell 1 failure
9	Load cell 2 failure
10	Load cell 3 failure
11	Load cell 4 failure
12	Left handle failure
13	Right handle failure
14	Middle handle failure
16	Main boom angle sensor 1 failure
17	Main boom angle sensor 2 failure
18	Main boom angle sensor failure
19	Boom length sensor 1 failure
20	Boom length sensor 2 failure
21	Main boom length sensor failure
22	Load cell failure
35	Tower boom up limit switch fault
36	Tower boom down limit switch fault
37	Safety protection fault
101	The maximum angle of the boom is limited upward
102	The minimum angle of the main boom is limited downward
103	The maximum length oh main boom extension limit
104	The minimum length of the main boom retracts limit
105	Turntable tilt
106	The turntable is tilted, the lift height of main boom exceeds 90cm, the main boom is limit to lift
107	The turntable is tilted, the extension length of the main boom exceeds 60cm, the main boom is in the upward range, and the main boom extension is limited
109	Drive does not enable travel function limit
110	Platform overload
113	Low fuel level alarm
114	Operating range exceeds the safety zone limit
115	Manual lock reminder
116	Manually lock the car



## Operation Manual of Articulated Boom Mobile Elevating Work Platform

117	GPS and ECU do not match
118	GPS is removed
119	The platform load is less than 100Kg
120	Operation sequence warning
121	Enable Timeout
122	Wrong selection of superstructure and chassis
125	Tower boom luffing limit
126	Tilt alarm, tower boom lifting
127	Low fuel level alarm

Table 9-1 System Fault Codes and Limiting Actions

### 9.14 After Each Use

- 1) Select a solid horizontal safe parking position in a moisture-proof, high temperature-resistant, open flame-proof, corrosive gas free and well-ventilated place.
- 2) Retract and lower the boom to the stowed state.
- 3) Turn the rotary table so that the boom is between the rear axle wheels.
- 4) Turn the key switch to the "OFF" position and remove the key to avoid unauthorized use.
- 5) Close and lock all hoods and doors.
- 6) Wipe off dust and oil stains on the body and keep the body clean.
- 7) When preparing the machine for outdoor storage, protect the exhaust pipe with a waterproof cover against rain and snow ingress into the muffler through it. (Caution: As the exhaust pipe can be hot just after the machine stops, use extreme caution to avoid scalding.)
- 8) Long-term storage
  - Disconnect the main power switch, and clean and maintain the whole machine before use.
  - When the storage period exceeds three months, it shall be operated once a month for not less than one hour each time, and cleaning and maintenance shall be carried out.
  - Secure the wheels using wheel chocks.



## **Chapter 10 Transportation Instructions**



**Operation Manual of Articulated Boom  
Mobile Elevating Work Platform**

---



## 10.1 Observing the Regulations

- 1) The driver shall be responsible for ensuring that the machine is properly fixed and that the appropriate trailer is selected in accordance with local traffic regulations.
- 2) Only the personnel qualified for lifting operation at heights can lift the machine.
- 3) The transport trailer must be parked on level ground.
- 4) When loading the machine, the transport vehicle must be secured to prevent movement.
- 5) Make sure that the vehicle load, loading surface, chains or belts, etc. are sufficient to support the weight of the machine. Please refer to the "nameplate" for the weight of the machine.

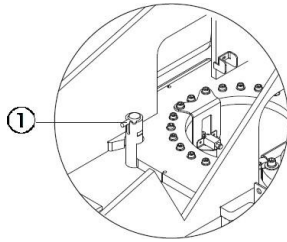

Fig. 10-1 Rotary table rotating lock pin

- 6) Ensure that the rotary table is secured with the rotary table rotary lock before transport, as shown in Figure 10-1. Ensure that the rotary table is unlocked during operation.
- 7) Do not drive the machine on a slope that exceeds the machine's uphill, downhill or slope rating. Refer to "driving on slopes" in the "operating instructions" section.
- 8) If the grade of the transport vehicle exceeds the maximum slope rating, a winch must be used to load and unload the machine according to the brake release instructions.
- 9) The platform is equipped with a precise weighing system. It is forbidden to place heavy objects on the platform during vehicle transportation, otherwise the weighing system may be damaged.

## 10.2 Brake Release

- 1) Block the wheel with a wedge to prevent

the machine from moving.

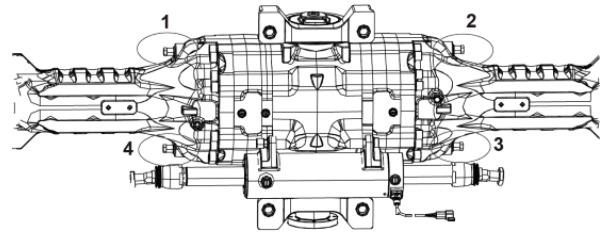

Figure 10-2 Brake release

- 2) Unscrew the four brake release screws of the rear axle inwards, as shown in Figure 10-2.
- 3) Act on front axle in the same way.
- 4) It must be ensured that the winch cable is properly secured to the fastening point of the drive chassis and there are no obstructions on the channel.
- 5) Perform the above procedure in reverse order to re-engage the brake.

## 10.3 Ensuring Transportation Safety

- 1) The rotary table should be locked with a turntable rotating locking pin each time the machine is transported, as shown in Fig. 10-1.
- 2) Before transportation, turn the key switch to the "off" position and remove the key.
- 3) Inspect the machine thoroughly to prevent loose or unsecured parts.
- 4) Fixed chassis:

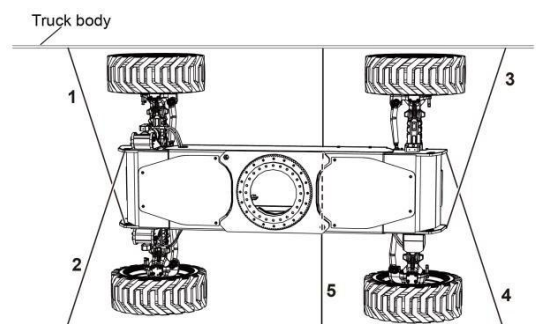

Fig. 10-3 Schematic diagram of fixed chassis

Ensure that the chain or belt has sufficient load strength and use at least 5 chains. Adjust the rigging to prevent damage to the chain, as



## Operation Manual of Articulated Boom Mobile Elevating Work Platform

shown in Figure 10-3.

### 5) Fixed platform:

Method 1:

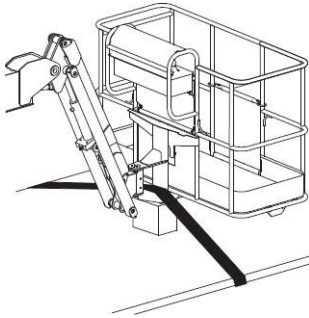

Figure 10-4 Schematic diagram of the fixed platform

Place the cushion block under the rotating connection of the platform and keep it away from the platform cylinder. Pass the nylon strap through the platform support to secure the platform. Do not apply excessive downward force when protecting boom components, as shown in Fig. 10-4.

Method 2:

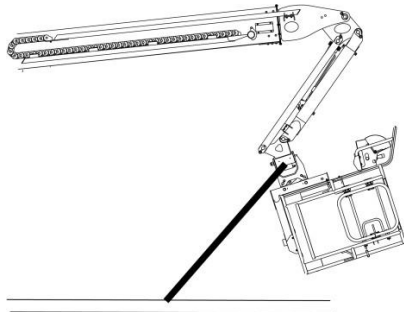

Fig. 10-5 Schematic Diagram of Fixed Platform

- Operate with GCU.
- Lower the jib boom to the stowed position.
- Lower the platform as much as possible so that the platform is under the boom.
- Pass the nylon strap through the platform support to secure the platform.
- Do not apply excessive downward force when protecting boom components.

## 10.4 Guidance for Lifting

- 1) Only qualified lifting and rigging assemblers can assemble rigging and lifting the

machine.

- 2) Ensure that the lifting capacity of the crane and the belts or ropes is sufficient to support the weight of the machine. Please refer to the "nameplate" for the weight of the machine.
- 3) Before hoisting, use the GCU to raise the jib boom to the horizontal position to prevent the platform from touching the ground during hoisting and causing deformation of the boom. The rest of the booms are completely lowered and retracted, removing all the moving parts and items on the machine.
- 4) Secure the turntable using the turntable rotary lock.
- 5) The rigging can only be attached to the designated lifting point on the machine.
- 6) Adjust the rigging to avoid damage to the machine and keep the machine level.

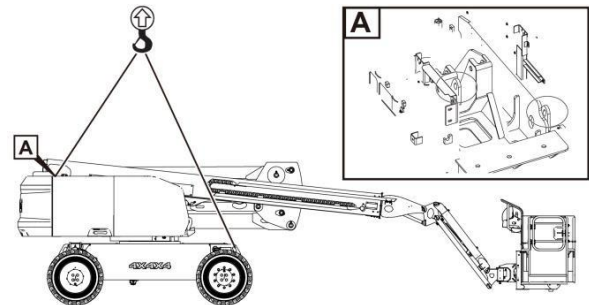

Figure 10-6 Lifting point (take AR20J as an example)

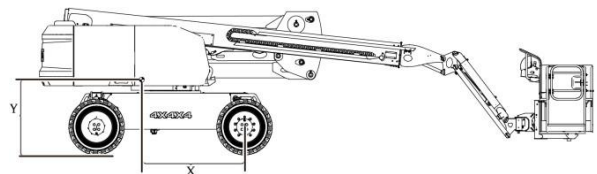

Figure 10-7 Center-of-gravity position of the machine

Type	X-axis (mm)	Y-axis (mm)
AR20J	1210	1180

Table 10-1

