

MODELS | SJ 46AJ SJ 51AJ



Operating Manual

Articulating Boom Series (CE)

143895AD-A January 2018



This manual is based on Serial Number(s):

SJ 46AJ/51AJ 95 000 001 - 95 000 335, 95 000 337 - 95 000 340, 95 000 342

Please refer to the website (www.skyjack.com) for older Serial Numbers.

Skyjack Service Center

3451 Swenson Ave. St. Charles,
Illinois, 60174 USA
Phone: 630-262-0005
Toll Free: 1-800-275-9522
Fax: 630-262-0006
Email: service@skyjack.com

Parts (North America)

Toll Free: 1-800-965-4626
Toll Free Fax: 1-888-782-4825
E-mail: parts@skyjack.com

Skyjack Australia Pty Ltd.

Unit 1, 35 Honeycomb Drive
Eastern Creek
New South Wales 2766
Australia
Tel: +61 (0) 2 9854 0700
Fax: +61 (0) 2 9854 0777

Parts & Service (Europe)

Unit 1 Maes Y Clawdd
Maesbury Road Industrial Estate
Oswestry, Shropshire SY10 8NN UK
Phone: +44-1691-676-235
Fax: +44-1691-676-238
E-mail: info@skyjackeurope.co.uk

Skyjack Brasil

Alameda Júpiter, 710
Loteamento American Park Empresarial
Indaiatuba, SP, Brasil 13347-653
Tel: +55 19 3936 0132

The Safety Alert Symbol identifies important safety messages on aerial platform, safety signs in manuals or elsewhere. When you see this symbol, be alert to the possibility of personal injury or death. Follow the instructions in the safety message.



This Safety Alert Symbol means attention!

Become alert! Your safety is involved.



DANGER

DANGER indicates an imminently hazardous situation which, if not avoided, will result in death or serious injury.



WARNING

WARNING indicates a potentially hazardous situation which, if not avoided, could result in death or serious injury.



CAUTION

CAUTION indicates a potentially hazardous situation which, if not avoided, may result in minor or moderate injury. It may also be used to alert against unsafe practices.

IMPORTANT

IMPORTANT indicates a procedure essential for safe operation and which, if not followed, may result in a malfunction or damage to the aerial platform.

This document is a translation from English.
In case of discrepancy between the English document and this document, the English version prevails.

Table of Contents

Section 1 - About Your Aerial Platform

Read and Heed

Aerial Platform Definition.....	7
Purpose of Equipment.....	7
Use of Equipment	7
Manual.....	7
Operator.....	7
Service Policy and Warranty.....	7
Optional Accessories.....	7
Scope of this Manual.....	7

Safety Rules

Operator Safety Reminders.....	8
Electrocution Hazard.....	8
Safety Precautions.....	9

Section 2 - Operation

2.1	General.....	13
2.1-1	Operator Qualifications	13
2.1-2	Operator's Responsibility for Maintenance.....	13
2.1-3	Maintenance and Inspection Schedule	13
2.1-4	Owner's Inspections.....	13
2.2	Major Components	14
2.3	Major Assemblies.....	15
2.3-1	Base.....	15
2.3-2	Turret.....	15
2.3-3	Boom Assembly	15
2.3-4	Platform	15
2.4	Serial Number Nameplate.....	15
2.5	Component Identification.....	16
2.5-1	Main Power Disconnect Switch & Battery Charge Indicator	16
2.5-2	Tilt Sensor.....	16
2.5-3	Drive Bypass Valve	16
2.5-4	Brake System	16
2.5-5	Differential Lock Switch.....	17
2.5-6	All Motion Alarm	17
2.5-7	AC Outlet on Platform (If Equipped)	17
2.5-8	Turret Transportation Lock	17
2.5-9	Footswitch	17
2.5-10	Manual Storage Box.....	17
2.5-11	Platform Load Sensing System.....	18
2.5-12	Base Control Console	20
2.5-13	Platform Control Console.....	22
2.6	Special Options.....	24
2.6-1	Cold Weather Start (If Equipped).....	24
2.6-2	Flashing Amber Light (If Equipped).....	24
2.7	Operator's Responsibility.....	25

Table of Contents

Section 2 - Operation (Continued)

2.8	Visual & Daily Maintenance Inspections.....	26
2.9	Function Tests	34
2.10	Start Operation.....	45
2.10-1	To Activate Base Control Console.....	45
2.10-2	To Rotate Platform Using Base Control Console.....	45
2.10-3	To Rotate Turret Using Base Control Console.....	46
2.10-4	To Move Jib Up and Down Using Base Control Console.....	46
2.10-5	To Move Riser Up and Down Using Base Control Console	46
2.10-6	To Raise or Lower Main Boom Using Base Control Console	46
2.10-7	To Extend or Retract Fly Boom Using Base Control Console	46
2.10-8	To Level Platform Manually Using Base Control Console	46
2.10-9	To Operate Using Emergency Power Switch at Base Control Console	47
2.10-10	To Activate Platform Control Console	47
2.10-11	To Drive Forward or Reverse	48
2.10-12	To Steer.....	48
2.10-13	To Move Jib Up and Down Using Platform Control Console	48
2.10-14	To Move Riser Up and Down Using Platform Control Console	48
2.10-15	To Extend or Retract Fly Boom Using Platform Control Console.....	48
2.10-16	To Rotate Platform Using Platform Control Console	49
2.10-17	To Level Platform Manually Using Platform Control Console.....	49
2.10-18	To Raise or Lower Main Boom Using Platform Control Console.....	49
2.10-19	To Sound Horn	49
2.10-20	To Rotate Turret Using Platform Control Console.....	49
2.10-21	To Operate Using Emergency Power Switch at Platform Control Console	49
2.10-22	Shutdown Procedure	50
2.10-23	Hydraulic Generator (If Equipped).....	50
2.11	Refueling Procedure	51
2.11-1	Regular Fuel (Diesel).....	51
2.12	Loading/Unloading	52
2.12-1	Loading and Tie-down	52
2.12-2	Locking the Turret.....	53
2.12-3	Lifting	53
2.13	Winching and Towing Procedure.....	54
2.13-1	To Release Brakes Manually	55
2.14	Emergency Lowering Procedures	56
2.15	Chassis Tilt.....	57
2.16	Diagrams.....	58
2.17	Tables	61
2.18	Labels	69

List of Tables

2.1	Standard and Optional Features	61
2.2	Specifications and Features.....	62
2.3	Owner's Annual Inspection Record	64
2.4	Tire/Wheel Specifications.....	64
2.5	Maximum Platform Capacities	64
2.6	Floor Loading Pressure.....	65
2.7	Maintenance and Inspection Schedule	66
2.8	Operator's Checklist	67
2.9	EC Declaration of Conformity	68

SKYJACK is continuously improving and expanding product features on its equipment, therefore, specifications and dimensions are subject to change without notice.

Aerial Platform Definition

A mobile device that has an adjustable position platform supported from ground level by a structure.

Purpose of Equipment

The SKYJACK Articulating Boom Series (Models SJ 46AJ & SJ 51AJ) aerial platform is designed to transport and raise personnel, tools and materials to overhead work areas.

Use of Equipment

The aerial platform is a highly maneuverable, mobile work station. Lifting and driving must be on a flat, level, compacted surface. It can be driven over uneven terrain only when the platform is fully lowered.

Manual

The operating manual is considered a fundamental part of the aerial platform. It is a very important way to communicate necessary safety information to users and operators. A complete and legible copy of this manual must be kept in the provided weather-resistant storage compartment on the aerial platform at all times.

Operator

The operator must read and completely understand both this operating manual and the safety panel label located on the platform and all other warnings in this manual and on the aerial platform. Compare the labels on the aerial platform with the labels found within this manual. If any labels are damaged or missing, replace them immediately.

Service Policy and Warranty

SKYJACK warrants each new articulating series work platform to be free of defective parts and workmanship for the first 24 months. Any defective part will be replaced or repaired by your local SKYJACK dealer at no charge for parts or labor. Contact the SKYJACK Service Department for warranty statement extensions or exclusions.

Optional Accessories

The SKYJACK aerial platform is designed to accept a variety of optional accessories. These are listed under "Standard and Optional Features" in [Table 2.1](#). Operating instructions for these options (if equipped) are located in [Section 2](#) of this manual.

For non-standard components or systems, contact the SKYJACK Service Department at

☎ : 44-1691-676-235

📠 : 44-1691-676-239

Include the model and serial number for each applicable aerial platform.

Scope of this Manual

- a. This manual applies to the CE version of the Articulating Boom aerial platform models listed in [Table 2.1](#).
 - Equipment identified with "CE" meets the requirements of the Machinery Directive 98/37/EC and the EMC Directive 2004/108/EC.
- b. Operators are required to conform to national, state or territorial/provincial and local health and safety regulations applicable to the operation of this aerial platform.



WARNING

Failure to comply with your required responsibilities in the use and operation of the aerial platform could result in death or serious injury!

Operator Safety Reminders

A study conducted by St. Paul Travelers showed that most accidents are caused by the failure of the operator to follow simple and fundamental safety rules and precautions.

You, as a careful operator, are the best insurance against an accident. Therefore, proper usage of this aerial platform is mandatory. The following pages of this manual should be read and understood completely before operating the aerial platform.

Common sense dictates the use of protective clothing when working on or near machinery. Use appropriate safety devices to protect your eyes, ears, hands, feet and body.

Any modifications from the original design are strictly forbidden without written permission from SKYJACK.

Electrocution Hazard

This aerial platform is not electrically insulated. Maintain a Minimum Safe Approach Distance (MSAD) from energized power lines and parts as listed below. The operator must allow for the platform to sway, rock or sag. This aerial platform does not provide protection from contact with or proximity to an electrically charged conductor.

**DO NOT USE AERIAL PLATFORM AS A GROUND FOR WELDING.
DO NOT OPERATE AERIAL PLATFORM DURING LIGHTNING OR STORMS.**

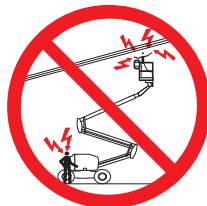

DANGER

Avoid Power Lines

Minimum Safe Approach Distance

CE Guidance Note

“Avoidance of danger from overhead lines”

Adhere strictly to the governmental rulings and regulations applicable in your country.

FAILURE TO AVOID THIS HAZARD WILL RESULT IN DEATH OR SERIOUS INJURY!

60023AE-CE

Safety Precautions

Know and understand the safety precautions before going on to next section.



WARNING

Failure to heed the following safety precautions could result in tip over, falling, crushing, or other hazards leading to death or serious injury.

- **KNOW** all national, state or territorial/provincial and local rules which apply to your aerial platform and jobsite.
- **TURN** main power disconnect switch “O” off when leaving the aerial platform unattended. Remove the key to prevent unauthorized use of the aerial platform.
- **WEAR** all the protective clothing and personal safety devices issued to you or called for by job conditions.

- **DO NOT** wear loose clothing, dangling neckties, scarves, rings, wristwatches or other jewelry while operating this aerial platform .

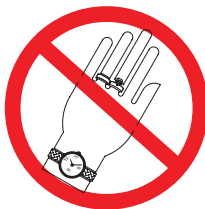

- **AVOID** entanglement with ropes, cords or hoses.



- **AVOID** falling. Stay within the boundaries of the guardrails.



- **DO NOT** raise the platform in windy or gusty conditions. Do not increase the lateral surface area of the platform. Increasing the area exposed to the wind will decrease aerial platform stability.



- **DO NOT** operate aerial platform during lightning or storms.



- **DO NOT** drive elevated near depressions or holes of any type, loading docks, debris, drop-offs and surfaces that may affect the stability of the aerial platform.

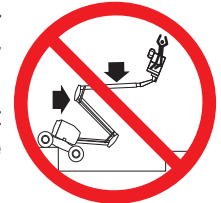

- **DO NOT** drive or elevate the aerial platform if it is not on a firm level surface.



- **Elevated driving** must only be done on a firm level surface.

- **If operation in areas with holes or drop-offs is absolutely necessary,** elevated driving shall not be allowed. Position the aerial platform horizontally only with the platform fully lowered. After ensuring that all 4 wheels or outriggers (if equipped) have contact with level firm surface, the aerial platform can be elevated. After elevation, the drive function must not be activated.



- **AVOID** soft, uneven surfaces.



- **DO NOT** ascend or descend a grade steeper than 45% (2WD & 4WD). Boom elevated driving must only be done on firm level surfaces.



Safety Precautions (Continued)

Know and understand the safety precautions before going on to next section.

- **DO NOT** operate an aerial platform that has ladders, scaffolding or other devices mounted on it to increase its size or work height.



- **ENSURE** that there are no personnel or obstructions in the path of travel, including blind spots.

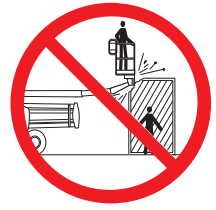

- **DO NOT** exert side forces on aerial platform while elevated.



- **DO NOT** lower the platform unless the area below is clear of personnel and obstructions.



- **DO NOT** use the aerial platform as a crane. It is prohibited.



- **DO NOT** use boom to push, pull other objects or to lift the chassis.



- **DO NOT** sit, stand or climb on the guardrails. It is prohibited.



- **DO NOT** raise the aerial platform while it is on a truck, forklift or other device or vehicle.



- **BE AWARE** of overhead obstructions or other possible hazards around the aerial platform when driving or lifting.



- **STUNT** driving and horseplay are prohibited.
- **ENSURE ALL** tires are in good condition and lug nuts are properly tightened.

- **BE AWARE** of crushing hazards. Keep all body parts inside platform guardrail.



- **DO NOT** alter or disable limit switches or other safety devices.

- **BE AWARE** of blind spots when operating the aerial platform.



- **DO NOT** exceed the rated capacity of the aerial platform. Do make sure the load is evenly distributed on the platform.

Safety Precautions (Continued)

Know and understand the safety precautions before going on to next section.

- **DO NOT** attempt to free a snagged platform with lower controls until personnel are removed from the platform.
- **DO NOT** position the aerial platform against another object to steady the platform.
- **DO NOT** place materials on the guardrails or materials that exceed the confines of the guardrails unless approved by Skyjack.

**WARNING**

Entering and exiting the aerial platform should only be done using the three points of contact.

- Use only equipped access openings.
- Enter and exit only when the aerial platform is in the fully retracted position.
- Do use three points of contact to enter and exit the platform. Enter and exit the platform from the ground only. Face the aerial platform when entering or exiting the platform.
- Three points of contact means that two hands and one foot or one hand and two feet are in contact with the aerial platform or the ground at all times during entering and exiting.

**WARNING**

An operator should not use any aerial platform that:

- does not appear to be working properly.
- has been damaged or appears to have worn or missing parts.
- has alterations or modifications not approved by the manufacturer.
- has safety devices which have been altered or disabled.
- has been tagged or locked out for non-use or repair.

Failure to avoid these hazards could result in death or serious injury.

Jobsite Inspection

- Do not use in hazardous locations.
- Perform a thorough jobsite inspection prior to operating the aerial platform, to identify potential hazards in your work area.
- Be aware of moving equipment in the area. Take appropriate actions to avoid collision.

2.0 Operation

This section provides the necessary information needed to operate the aerial platform. It is important that the user reads and understands this section before operating the aerial platform.

2.1 General

In order for this aerial platform to be in good working condition, it is important that the operator meets the necessary qualifications and follow the maintenance and inspection schedule referred to in this section.

2.1-1 Operator Qualifications

- Only trained and authorized personnel shall be permitted to operate an aerial platform.
- Safe use of this aerial platform requires the operator to understand the limitations and warnings, operating procedures and operator's responsibility for maintenance. Accordingly, the operator must understand and be familiar with this operating manual, its warnings and instructions, and all warnings and instructions on the aerial platform.
- The operator must be familiar with employer's work rules and related government regulations and be able to demonstrate the ability to understand and operate this make and model of aerial platform in the presence of a qualified person.

2.1-2 Operator's Responsibility for Maintenance



WARNING

Maintenance must be performed by trained and competent personnel who are familiar with mechanical procedures.

Death or serious injury could result from the use of an aerial platform that is not properly maintained or kept in good working condition.

- The operator must be sure that the aerial platform has been properly maintained and inspected before using it.
- The operator must be sure that a complete and legible copy of the Certificate of Inspection and Testing kept in the provided weather-resistant storage compartment on the aerial platform at all times.
- The operator must perform all the daily inspections and function tests found in [Table 2.7](#), even if the operator is not directly responsible for the maintenance of this aerial platform.

2.1-3 Maintenance and Inspection Schedule

- The inspection points covered in [Table 2.7](#) indicate the areas of the aerial platform to be maintained or inspected and at what intervals the maintenance and inspections are to be performed.
- The actual operating environment of the aerial platform may affect the maintenance schedule.



WARNING

Use original or manufacturer-approved parts and components for the aerial platform.

2.1-4 Owner's Inspections

It is the responsibility of the owner to arrange daily, quarterly (or 150 hours) and annual inspections of the aerial platform. Refer to [Table 2.7](#) for recommended maintenance and inspection areas and intervals. A record of annual inspection is kept on a label located close to the base control console on the cowling. Refer to [Table 2.3](#) in this manual.

NOTE

Inspection scheduling requirements may vary. Owners must comply with local standards and regulations.

2.2 Major Components

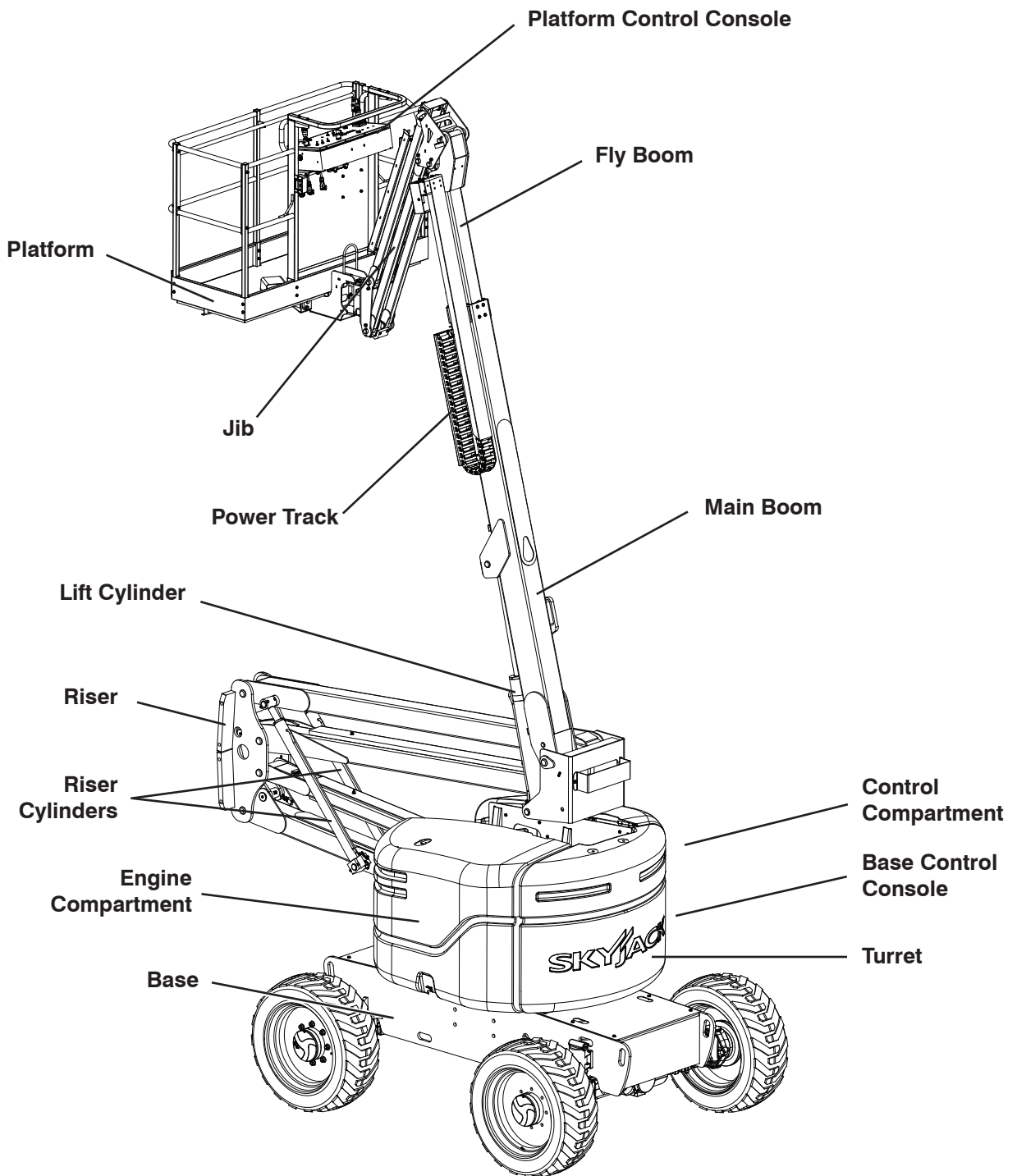

SKYJACK Articulating Boom

2.3 Major Assemblies

The aerial platform consists of four major assemblies: the base, turret, boom assembly and platform.

2.3-1 Base

The base is a rigid one-piece weldment. Models equipped with dual-fuel engine have mounting straps for propane tank on each side. The rear axle is hydraulic motor-driven and has a spring-applied, hydraulically released brakes. The front axle is steerable by a hydraulic cylinder. The rear axle is coupled to the front axle by a drive shaft.

2.3-2 Turret

The turret rotates 360 degrees continuously. Upon the turret are two compartments. One compartment contains the engine, hydraulic pumps and battery. The swing drive is in the center of the turret underneath the main boom. The other compartment contains the base control console, main hydraulic manifold, function valves, the hydraulic and fuel tanks.

2.3-3 Boom Assembly

The boom assembly consists of the riser, telescoping fly and main boom assembly. The riser is mounted on the turret with the main boom attached to the riser. The riser mechanism uses two double-acting hydraulic cylinders with holding valves to control vertical movement. AJ models are equipped with a 152 cm (60 in.) jib, controlled by a double-acting hydraulic cylinder.

2.3-4 Platform

The platform is constructed of a skid-resistant deck surface allowing visibility through the deck and a 110 cm (43 in.) high tubular steel railing system with mid rails and 15 cm (6 in.) toe boards. The platform can be entered through a swing gate at the side of the railing system. The platform can be rotated in either direction. An optional AC outlet is also located on the platform.

2.4 Serial Number Nameplate

The serial number nameplate, located at the rear of the aerial platform, lists the following:

- Model number
- Serial number
- Maximum capacities
- Maximum number of persons permissible on the platform
- Maximum manual force
- Aerial platform weight
- Maximum drivable height
- Maximum platform height
- System pressure
- Lift pressure
- Maximum wheel load
- Maximum wind speed
- Voltage
- Maximum inclination of chassis

2.5 Component Identification

The following descriptions are for identification, explanation and locating purposes only.

2.5-1 Main Power Disconnect Switch & Battery Charge Indicator

This main power disconnect switch and battery charge indicator are located in the engine compartment near the battery.

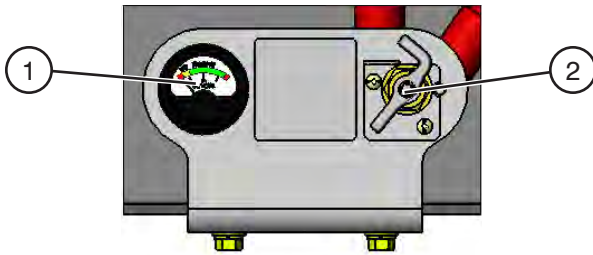

Figure 2-1. Main Power Disconnect Switch & Battery Charge Indicator

1. **Battery Charge Indicator** - When main power disconnect switch is in “I” on position, the battery voltage is displayed on the charge indicator. Refer to [Section 2.9-2](#) for instructions on different voltage levels of the battery.
2. **Main Power Disconnect Switch** - This switch, when in “O” off position, disconnects power to all circuits. Switch must be in “I” on position to operate any circuit. Turn switch “O” off when transporting aerial platform.

2.5-2 Tilt Sensor

The tilt sensor is located on top or inside the base control console. It is designed to prevent driving when aerial platform is on a slope greater than a predetermined limit.



WARNING

If aerial platform becomes tilted causing alarm to sound, the platform must be fully lowered immediately. Ensure that aerial platform is on a firm level surface before operating the aerial platform. Refer to [Section 2.15](#) for instructions regarding recovery from an inclined position.

2.5-3 Drive Bypass Valve

This valve is located on the inboard side of the drive pump and can be identified with a yellow paint mark on it.

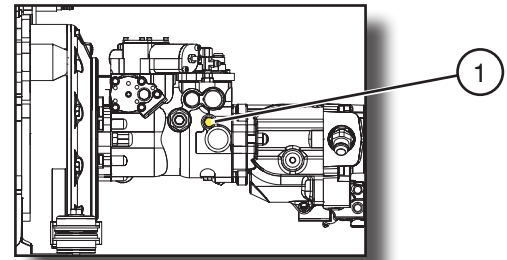

Figure 2-2. Drive Bypass Valve

1. **Drive Bypass Valve with Override Stems** - This valve, when loosened two revolutions counterclockwise, is used to override drive relief valves so that the aerial platform can be loaded or unloaded from a trailer using a winch line.

2.5-4 Brake System

The brake system is located in the control compartment. The brakes must be manually disengaged before pushing, winching or towing. Refer to [Section 2.13-1](#) for procedure on how to release brakes manually. The system contains the following controls:

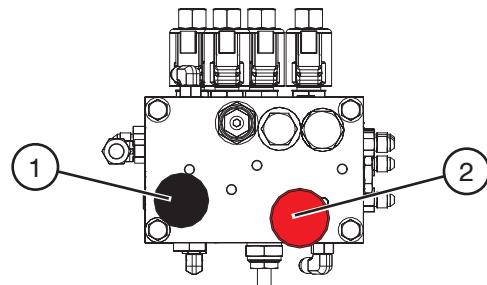

Figure 2-3. Brake System

1. Brake Auto Reset Valve Plunger
2. Brake Hand Pump

2.5-5 Differential Lock Switch

This switch is located on the platform control console. The differential locking system provides more traction by providing equal drive to each wheel regardless of traction. Differential locks are used to prevent from getting stuck when driving on loose, muddy, or rocky terrain. Refer to [Section 2.9-4](#) for instruction regarding testing differential lock switch.



WARNING

Before engaging differential lock, ensure drive/steer controller is in neutral position.

2.5-6 All Motion Alarm

This alarm produces an audible sound when any aerial platform function is activated. On aerial platforms with certain options, a flashing amber light will accompany this alarm.

2.5-7 AC Outlet on Platform (If Equipped)

This outlet is a source of AC power on the platform. The outlet is located on the right side of platform control console and the plug is located at the middle rear section of the turret.

2.5-8 Turret Transportation Lock

This locking device is located in the turret.

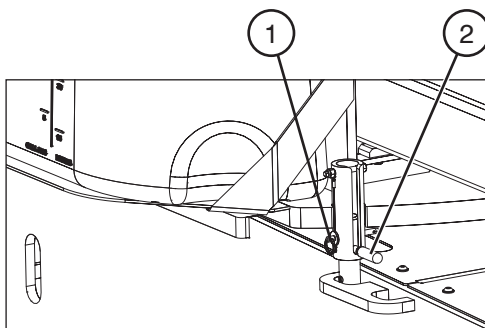

Figure 2-4. Turret Transportation Lock

- 1. Turret Transportation Lock Retaining Pin** - This retaining pin is used to hold transportation lock in either locked or unlocked position.
- 2. Turret Transportation Lock** - This locking device is used to lock turret in place during shipping only.

Refer to [Section 2.12-2](#) for procedure on how to lock the turret.

2.5-9 Footswitch

The footswitch is located on the floor of the platform. When depressed and held, it enables controls on platform control console.

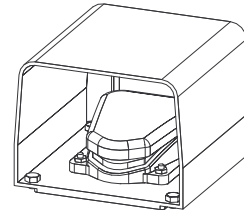

Figure 2-5. Footswitch

NOTE

The footswitch is equipped with a 15-second anti-tiedown feature that deactivates footswitch when operator depresses it for 15 seconds without activating any function.

2.5-10 Manual Storage Box

This weather-resistant box is mounted under the control console on the platform. It contains the operating manual, EC declaration and other important documents. The operating manual for this make and model of aerial platform must remain with the aerial platform and should be stored in this box.



2.5-11 Platform Load Sensing System

The platform load sensing system is a device that senses for an overload on the platform before the system disables boom and drive functions. This system is active when aerial platform is powered on.

When the platform is overloaded while in work mode (boom is raised greater than 15 degrees from horizontal or is extended greater than 6 inches), the load sensing system will disable all normal functions and signal the operator with an indicator light and an audible alarm.

When the platform is overloaded while in travel mode, the load sensing system will signal the operator with an indicator light and an audible alarm but will not disable any normal functions.

The following table shows the progression of warnings, indicated to the operator, up to the point of overload.

Overload Status Chart

Weight	Indicator Light	Audible Alarm	Aerial Platform System
93%	On	Off	Enabled
100%	Flashing	Off	Enabled
≥ 100% (Work Mode)	Flashing	Pulsing	Disabled
≥ 100% (Travel Mode)	Flashing	Pulsing	Enabled

NOTE

If the platform is overloaded due to contact with an overhead obstruction, do one of the following:

- Remove the obstruction from the platform, then after a four-second delay normal functions can be resumed.
- Use the emergency power unit at the base control console to release the platform from the obstruction.

2.5-12 Base Control Console

This control console is located in the panel mounted in the control compartment.

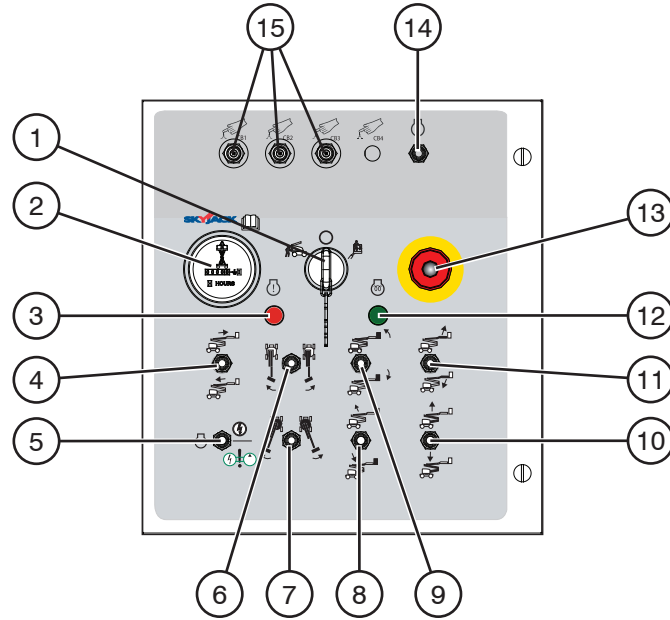

Figure 2-6. Base Control Console

1. **Base/Off/Platform Key Switch** - This three-way selector switch allows operator to “O” turn off power to aerial platform or to activate either “” base or “” platform control console.
2. **Hourmeter** - This gauge records accumulated operating time of engine.
3. **Engine Fault** - This light indicates failure in engine control system.
4. **Fly Boom Extend/Retract Switch** - This switch controls “” extension or “” retraction of fly boom.
5. **Start/Function Enable/Emergency Power Switch** - This momentary switch, when held in “” start position, starts engine. When held in “” function enable position, allows base control functions to operate. With engine off, and when held in “” emergency power unit position, allows base control functions to operate using emergency power unit.
6. **Platform Rotation Switch** - This switch controls “” left or “” right rotation of platform.
7. **Turret Rotation Switch** - This switch controls “” left or “” right rotation of turret.
8. **Main Boom Raise/Lower Switch** - This switch controls “” raising or “” lowering of main boom.
9. **Platform Leveling Override Switch** - This switch overrides automatic leveling of platform and controls “” tilting up or “” tilting down of platform.
10. **Riser Raise/Lower Switch** - This switch controls “” raising or “” lowering of riser.
11. **Jib Up/Down Switch** - This switch controls “” up or “” down movement of jib.

2.5-12 Base Control Console (Continued)

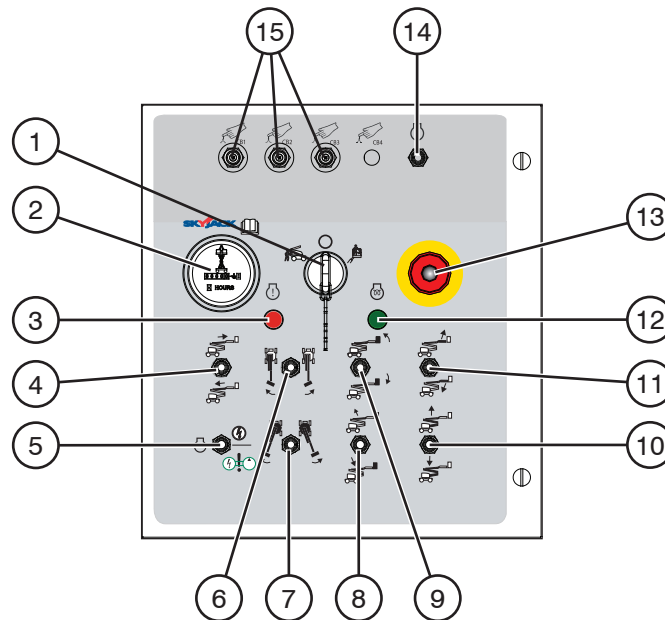



Figure 2-6. Base Control Console

- 12. **Glow Plug (Diesel)** - This light illuminates until glow plugs have completed their timed cycle. When the lamp goes out, the engine is ready to be started..
- 13. **Emergency Stop Button** - This red “mushroom-head” “” pushbutton disconnects power to control circuit and shuts engine off.
- 14. **Engine Diagnosis Switch** - When held in either direction, this switch “” enables an error blink code for engine control unit (ECU).
- 15. **Circuit Breakers** - In the event of a power overload or positive circuit grounding, the circuit breaker pops out. Push breaker back in to reset.

2.5-13 Platform Control Console

This metal control console is mounted at front guardrail of the platform. It has the following controls:

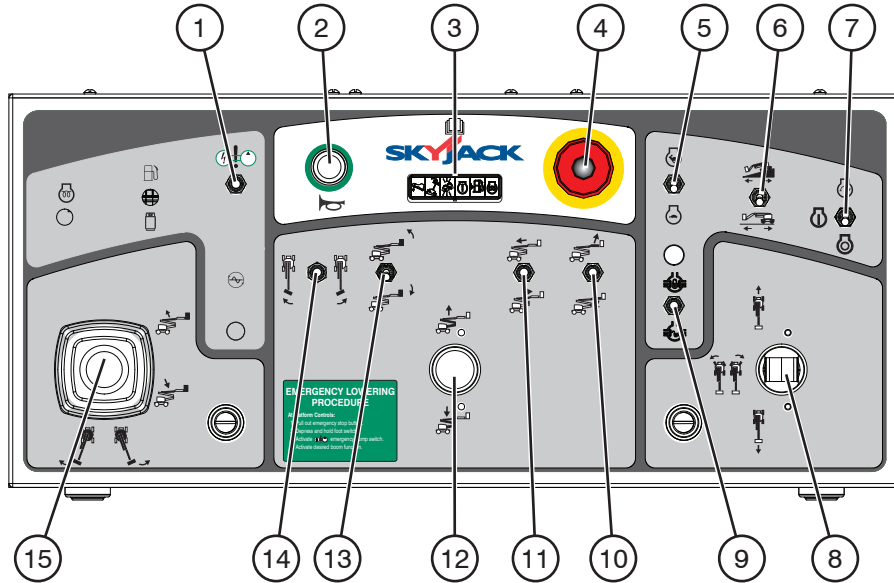
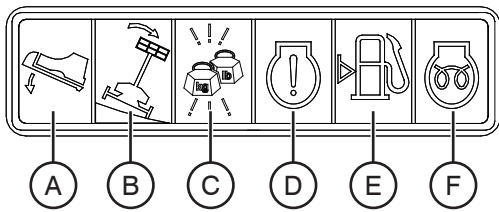

Figure 2-7. Platform Control Console

- 1. **Emergency Power Unit** - This switch “⚡⏻” enables emergency power unit.
- 2. **Horn Pushbutton** - This “📢” pushbutton sounds an automotive-type horn.
- 3. **Status Indicator Pilot Lights** - These lights indicate operational status and errors in any function in the controls/engine.



- A. **Footswitch** - This light illuminates when footswitch is depressed. A 15-second anti-tiedown feature deactivates footswitch when operator depresses it for 15 seconds without activating any function.
- B. **Chassis Tilt** - This light illuminates when the aerial platform chassis is at an inclination that activates the tilt sensor. At this inclination, an audible alarm will sound at the platform. Refer to Section 2.15 for instructions regarding recovery from an inclined position.

- C. **Overload Light** - This red light indicates overload status. Refer to Section 2.5-11.
- D. **Engine** - This light indicates failure in engine control system.
- E. **Fuel** - This light indicates low fuel level.
- F. **Glow Plug (Diesel)** - This light illuminates until glow plugs have completed their timed cycle. When the lamp goes out, the engine is ready to be started.

- 4. **Emergency Stop Button** - This red “mushroom-head” “🛑” pushbutton disconnects power to control circuit and shuts engine off.
- 5. **Low/High Throttle Switch** - This rotary switch allows selection between “📉” low and “📈” high engine throttle speeds.
- 6. **Torque Switch** - This switch selects “↔️” low or “📈” high torque.

2.5-13 Platform Control Console (Continued)

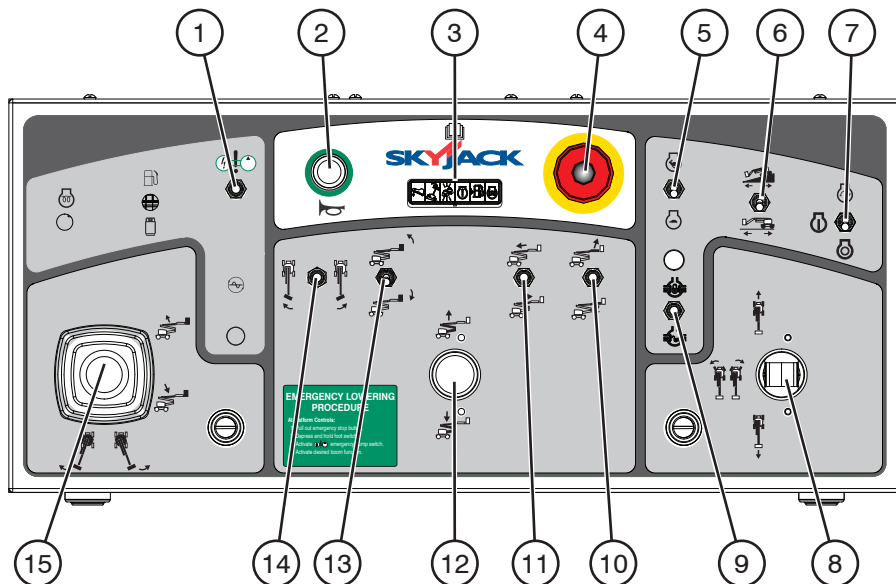













Figure 2-7. Platform Control Console



7. Engine Start/On/Off Switch - This switch, when held momentarily in “” start position, starts engine. Once started, the switch returns to “” on position. When in “” off position, it turns engine off.



8. Drive/Steer Controller - This one-hand lever controls driving “” forward or “” backward.



The rocker switch controls steering “” left or “” right. Internal springs return it to neutral when stick is released.



9. Differential Lock Switch - This momentary switch, when pushed forward and then released, engages “” differential lock and turns differential light on. When pulled backward and then released, disengages “” differential lock and turns differential light off.





10. Jib Up/Down Switch - This switch controls “” up or “” down movement of jib.

11. Fly Boom Extend/Retract Switch - This switch controls “” extension or “” retraction of fly boom.

12. Riser Raise/Lower Switch - This switch controls “” raising or “” lowering of riser.

13. Platform Leveling Override Switch - This switch overrides automatic leveling of platform and controls “” tilting up or “” tilting down of platform.

14. Platform Rotation Switch - This switch controls “” left or “” right rotation of platform.

15. Boom/Turret Controller - This dual-axis lever controls “” raising or “” lowering of main boom or rotating “” left or “” right of turret.

2.6 Special Options

The following descriptions are for identification, explanation and locating purposes only.

2.6-1 Cold Weather Start (If Equipped)

The battery warmer/hydraulic oil heater cord is located on the engine compartment near the battery. This cord is plugged into the AC outlet at least 4 hours before starting engine when temperature gets below -11°C (+11°F).

2.6-2 Flashing Amber Light (If Equipped)

The flashing amber light is located on top of the turret of the aerial platform. This light flashes when boom function is activated. This works in conjunction with all motion alarm.

NOTE

The combined weight of attachment, panels, occupants and tools should not exceed platform rated capacity.

2.7 Operator's Responsibility

It is the responsibility of the operator, prior to each work shift, to perform the following:

1. Visual and Daily Maintenance Inspections

- are designed to discover any damage of components before the aerial platform is put into service.
- are done before the operator performs the function tests.



WARNING

Failure to locate and repair damage, and discover loose or missing parts may result in an unsafe operating condition.

2. Function Tests

- are designed to discover any malfunctions before the aerial platform is put into service.

IMPORTANT

The operator must understand and follow the step-by-step instructions to test all aerial platform functions.

The operator should make a copy of the Operator's Checklist (see [Table 2.8](#)) and fill out the visual and daily maintenance inspections and the function tests sections while performing the items outlined in [Section 2.8](#) and [Section 2.9](#).

IMPORTANT

If aerial platform is damaged or any unauthorized variation from factory-delivered condition is discovered, aerial platform must be tagged and removed from service.

Repairs to the aerial platform may only be made by a qualified service technician. After repairs are completed, the operator must perform visual and daily maintenance inspections & function tests again.

Scheduled maintenance inspections shall only be performed by qualified service technician (see [Table 2.7](#)).

3. Cold Weather Hydraulic System Warm Up



WARNING

Caution must be exercised when operating aerial platform in cold temperature. Cold temperature can affect the performance of the aerial platform. Braking response and other functions may delay.



CAUTION

Ensure hydraulic oil throughout system is warmed before operating aerial platform in low temperatures. Failure to heed this warning can lead to unexpected movements, product damage, death or serious injury.

Boom Functions:



WARNING

Be aware of overhead obstructions or other possible hazards around the aerial platform when lifting.

- Run engine at low throttle.
- Raise, lower, extend and retract boom slowly several times until boom functions are at acceptable operating performance.

Drive Functions:



WARNING

Ensure that there are no personnel or obstructions in the path of travel, including blind spots.

- Run engine (if applicable) in low throttle.
- Drive aerial platform forward and backward slowly several times until braking response is in safe operating performance.

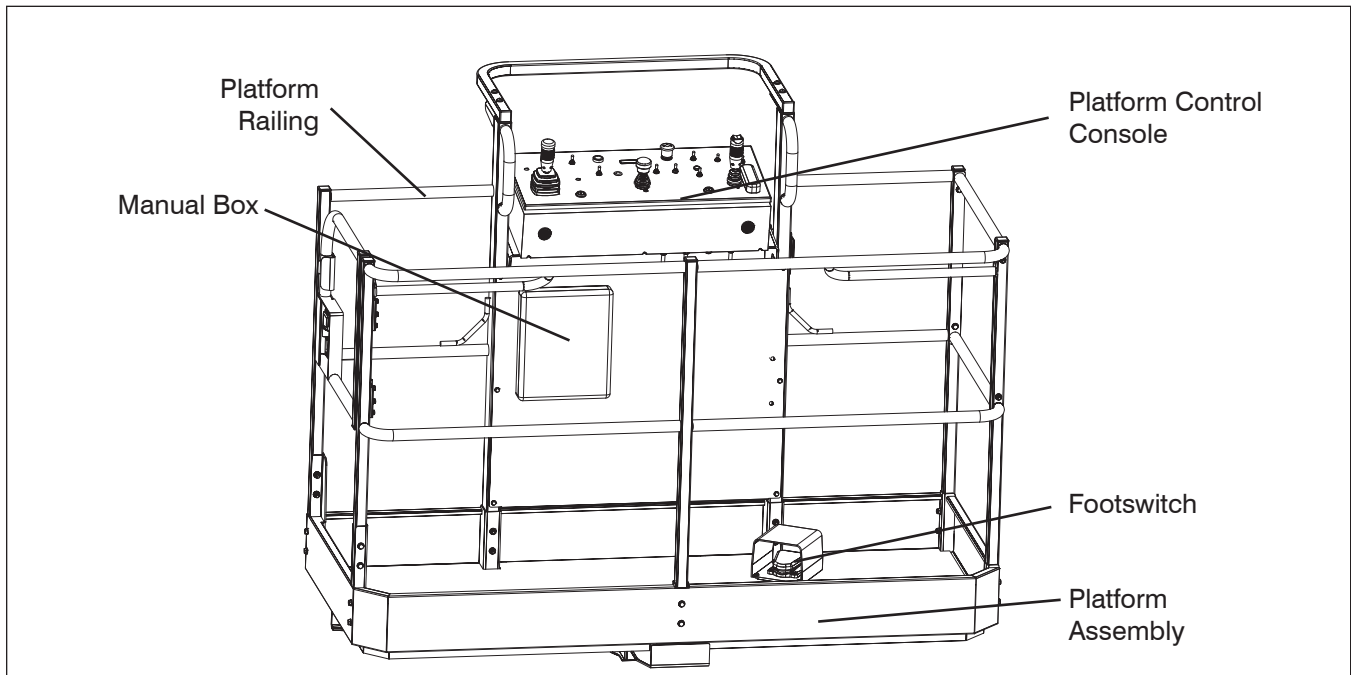

2.8 Visual & Daily Maintenance Inspections

Begin the visual and daily maintenance inspections by checking each item in sequence for the conditions listed in this section.



WARNING

To avoid injury, do not operate an aerial platform until all malfunctions have been corrected.



WARNING

To avoid possible injury, ensure aerial platform power is off during your visual and daily maintenance inspections.

NOTE

While doing visual and daily inspections in different areas, be aware to also inspect limit switches, electrical and hydraulic components.

2.8-1 Labels

Refer to the labels section in this manual and determine that all labels are in place and are legible.

2.8-2 Electrical

Maintaining the electrical components is essential to good performance and service life of the aerial platform.

Inspect the following areas for chafed, corroded and loose wires:

- boom to platform cable harness
- engine compartment electrical panel
- engine wiring harness
- rotary manifold wiring

2.8-3 Limit Switches

Ensure limit switches are properly secured with no signs of visible damage and movement is not obstructed.

2.8-4 Hydraulic

Maintaining the hydraulic components is essential to good performance and service life of the aerial platform.

Perform a visual inspection around the following areas:

- hydraulic tank filter, fittings, hoses, emergency power unit and turret/base surface
- engine compartment fittings, hoses, main pump, filter and turret/base surface
- all hydraulic cylinders
- all hydraulic manifolds
- underside of the turret
- underside of the base
- ground area under the aerial platform

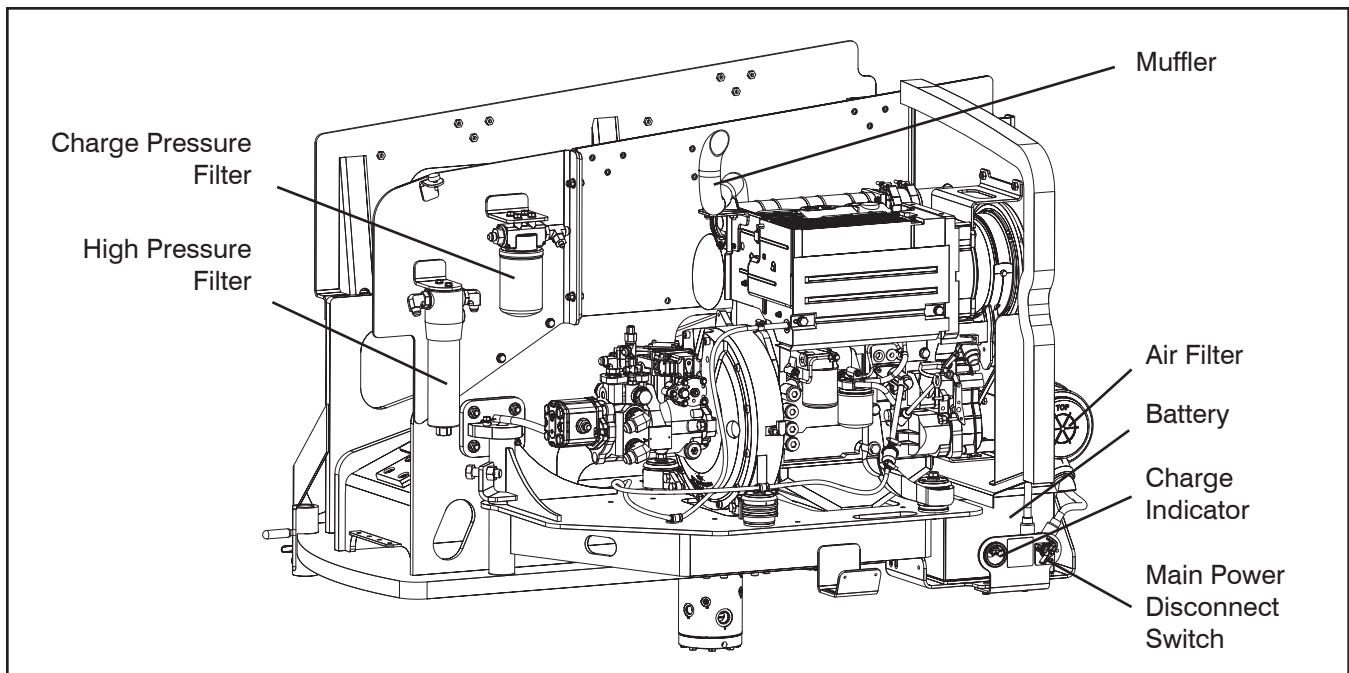

2.8-5 Engine Compartment

- Ensure all compartment latches are secure and in proper working order.
- **Main Power Disconnect Switch**
 - Turn main power disconnect switch to “○” off position.
 - Ensure there are no loose or missing parts and there is no visible damage.
 - Ensure all cables are secure and switch is in proper working condition.
- **Battery**
 1. Check battery cases for damage.
 2. Clean battery terminals and cable ends thoroughly with a terminal cleaning tool or wire brush.
 3. Ensure all battery connections are tight.
 4. If applicable, check battery fluid level. If plates are not covered by at least 13 mm (1/2”) of solution, add distilled or demineralized water.
 5. Replace battery if damaged or incapable of holding a lasting charge.

Proper battery condition is essential to good engine performance and operational safety. Improper fluid levels or damaged cables and connections can result in engine component damage and hazardous conditions.



WARNING

Explosion hazard. Keep flames and sparks away. Do not smoke near batteries.



WARNING

Battery acid is extremely corrosive - Wear proper eye and facial protection as well as appropriate protective clothing. If contact occurs, immediately flush with cold water and seek medical attention.



WARNING

Use original or manufacturer-approved parts and components for the aerial platform.

- **Charge Indicator**

- Ensure there are no loose or missing parts and there is no visible damage.

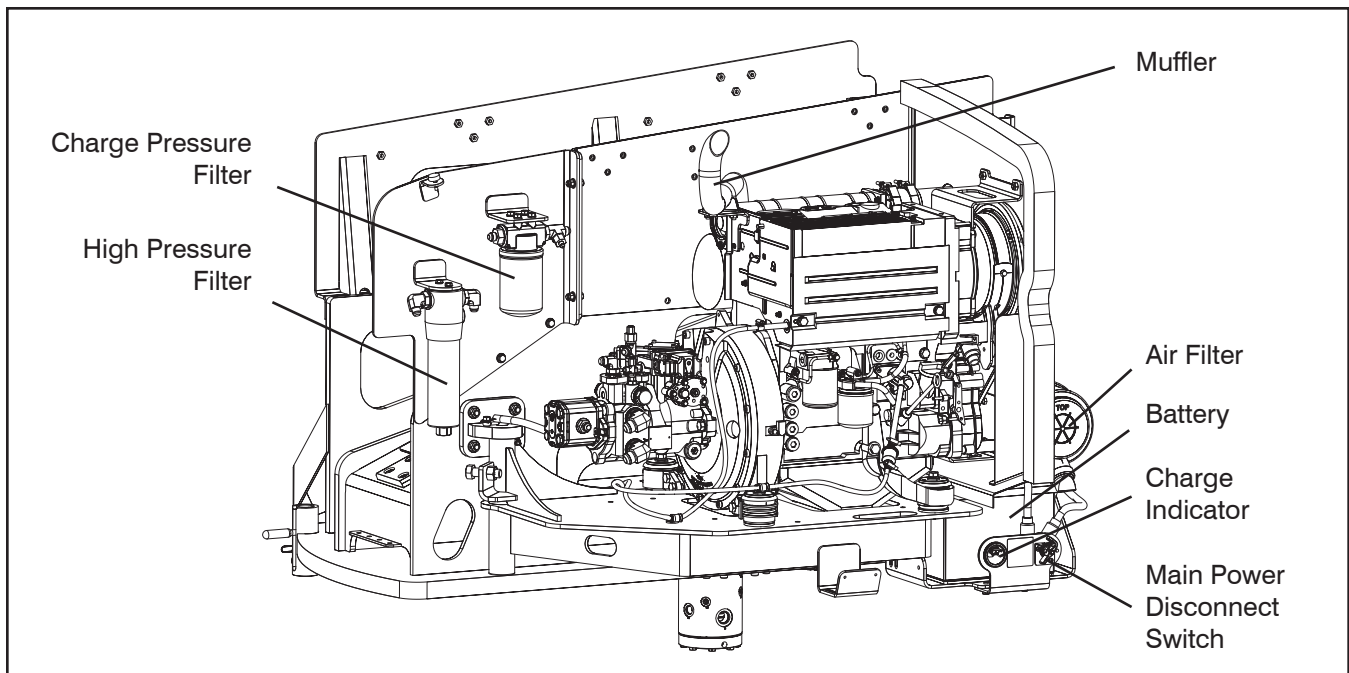

- **High Pressure Filter**
 - Ensure housing is secure and shows no visible damage or leakage.
- **Hydraulic Pumps**
 - Ensure there are no loose or missing parts and there is no visible damage.
 - Ensure all bolts are properly tightened.
 - Ensure all fittings and hoses are properly tightened and there is no evidence of hydraulic leakage.
- **Muffler and Exhaust**
 - Ensure muffler and exhaust system are properly secured, with no evidence of damage.
- **Engine Pivot Tray**
 - Ensure there are no loose or missing parts and no visible damage to the engine pivot tray. Ensure that quick release pin is in place.
- **Engine Oil Level**
 - Maintaining the engine components is essential to good performance and service life of the aerial platform.



WARNING

Beware of hot engine components.

Check oil level on dipstick

- Oil level should be in the “safe” zone. Add oil as needed. Refer to [Table 2.2b](#) for recommended oil type.

- **Engine Air Filter**
 - Ensure there are no loose or missing parts and there is no visible damage.
- **Fuel Leaks**
 - Ensure that there no fuel leaks.



DANGER

Engine fuels are combustible. Inspect the aerial platform in an open, well-ventilated area away from heaters, sparks and flames. Always have an approved fire extinguisher within easy reach.

- Ensure fuel tank, hoses and fittings show no visible damage and no evidence of fuel leakage.

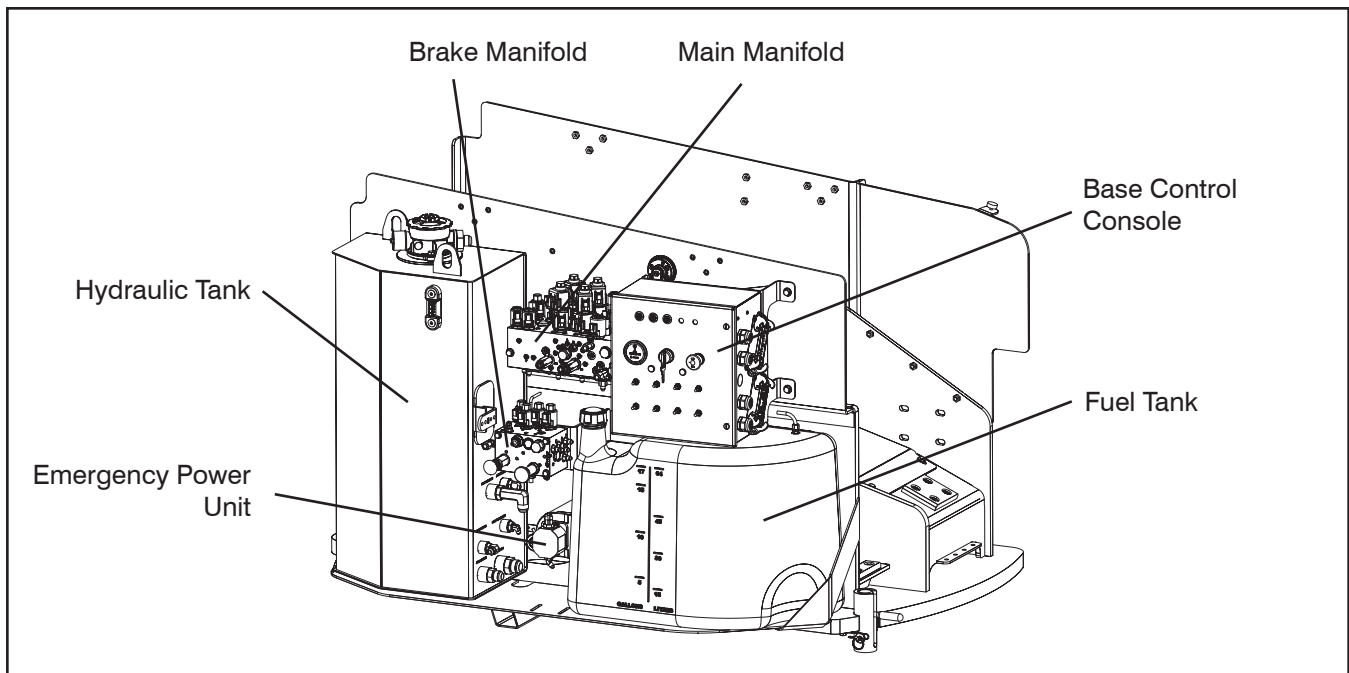

2.8-6 Control Compartment

- Ensure all compartment latches are secure and in proper working order.
- **Base Control Console**
 - Ensure all switches are returned to their neutral positions.
 - Ensure there are no loose or missing parts and there is no visible damage.
- **Hydraulic Tank**
 - Ensure hydraulic filler cap is secure.
 - Ensure tank shows no visible damage and no evidence of hydraulic leakage.
- **Hydraulic Oil**
 - Be sure that the boom is in the stowed position, and then visually inspect the sight gauge located on the side of the hydraulic oil tank.
 - The hydraulic oil level should be between the minimum and maximum marks on the sight glass. Add oil as needed. Refer to [Table 2.2b](#) for recommended oil type.
- **Brake and Main Manifolds**
 - Ensure all fittings and hoses are properly tightened and there is no evidence of hydraulic leakage.
 - Ensure there are no loose wires or missing fasteners.
- **Emergency Power Unit**
 - Ensure there are no loose or missing parts and there is no visible damage.
 - Ensure there are no loose wires or missing fasteners.
 - Ensure all fittings and hoses are properly tightened and there is no evidence of hydraulic leakage.
- **Fuel Tank**
 - Ensure fuel filler cap is secure.
 - Ensure tank shows no visible damage and no evidence of fuel leakage.

IMPORTANT

Before using your aerial platform ensure there is enough fuel for expected use.

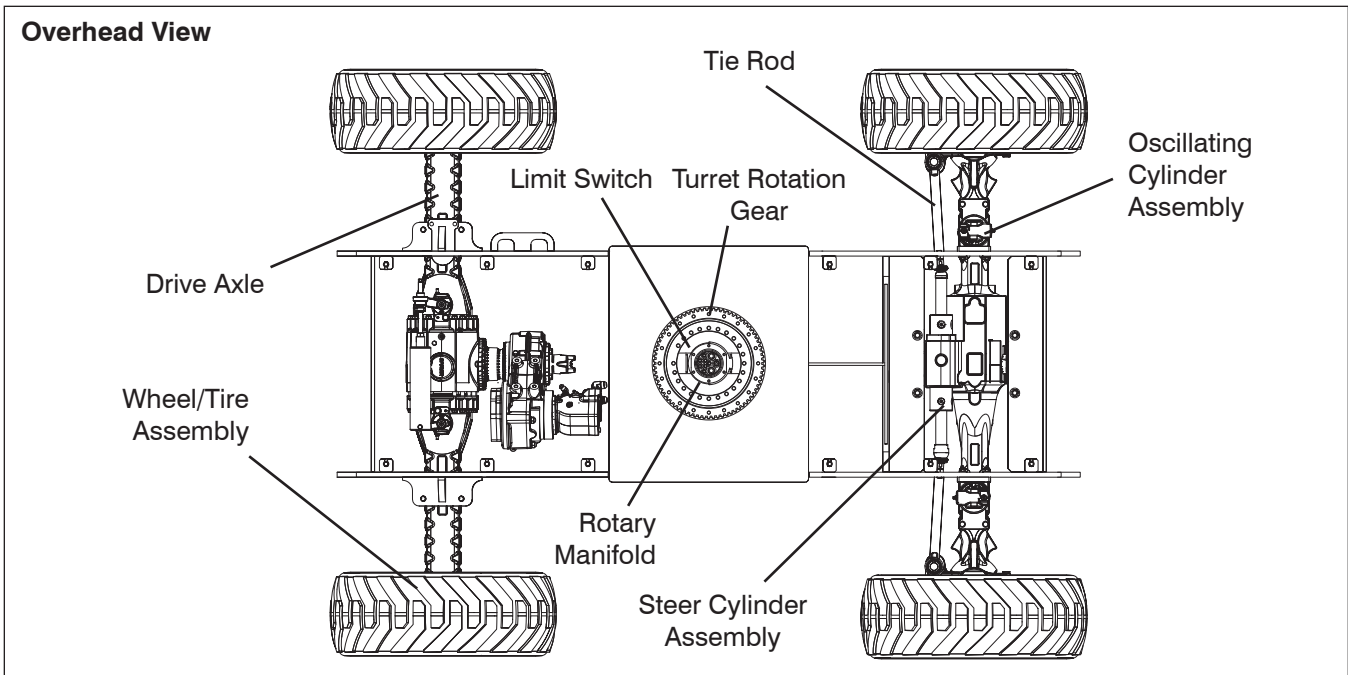

- **Fuel Leaks**
 - Ensure that there no fuel leaks.



Engine fuels are combustible. Inspect the aerial platform in an open, well-ventilated area away from heaters, sparks and flames. Always have an approved fire extinguisher within easy reach.

- Ensure fuel tank, shutoff valve, hoses and fittings show no visible damage and no evidence of fuel leakage.

2.8-7 Base

- **Turret Transportation Lock**
 - Ensure turret transportation lock is unlocked, there are no loose or missing parts and there is no visible damage.
- **Drive Axle**
 - Ensure drive axle is properly secured, there are no loose or missing parts, all fittings and hoses are properly tightened and there is no evidence of hydraulic leakage.

- **Oscillating Cylinder Assembly**
 - Ensure oscillating cylinder assembly is properly secured, there are no loose or missing parts, all fittings and hoses are properly tightened and there is no evidence of hydraulic leakage.

NOTE

Oscillating axle is locked when aerial platform is in work mode. Refer to [Diagram 2.3. Axle Oscillation Diagram](#).

- **Steer Cylinder Assembly**
 - Ensure steer cylinder assembly is properly secured, there are no loose or missing parts, all fittings and hoses are properly tightened and there is no evidence of hydraulic leakage.
- **Tie Rod**
 - Ensure there are no loose or missing parts, tie rod end studs are locked and there is no visible damage.

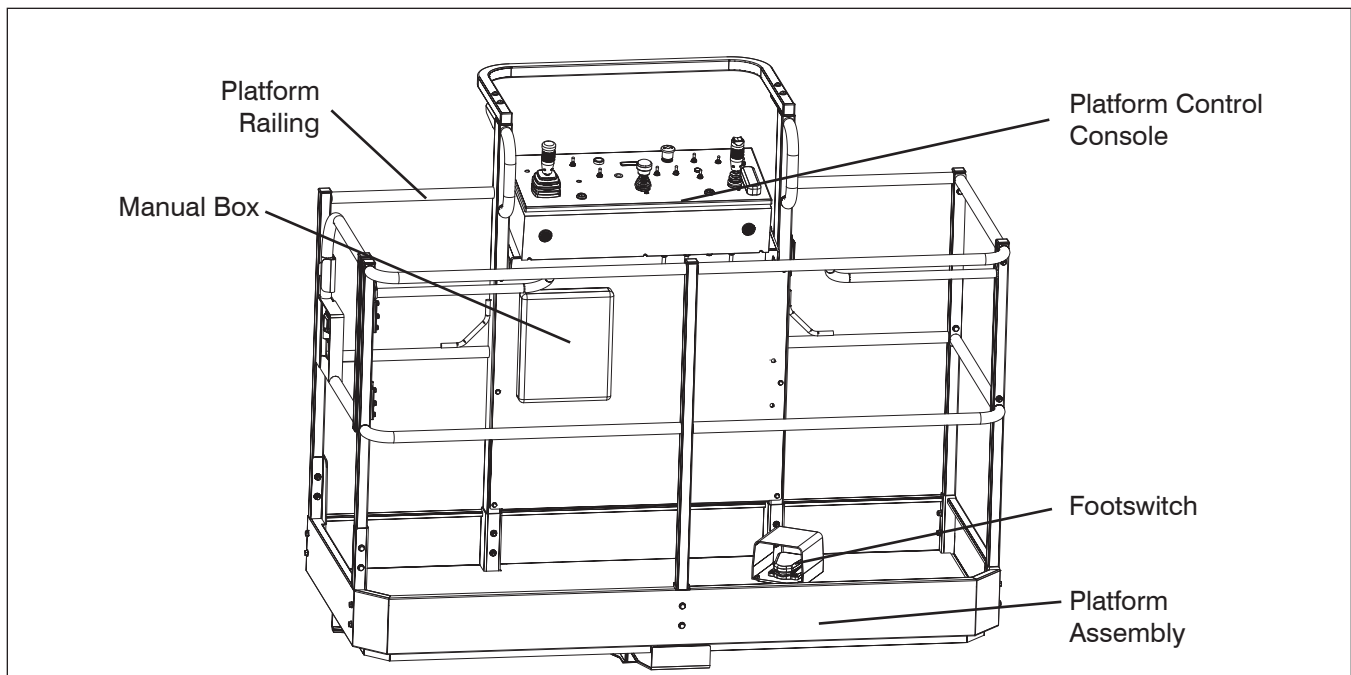

- **Wheel/Tire Assembly**

The aerial platform is equipped with foam-filled tires. Tire and/or wheel failure could result in an aerial platform tip over. Component damage may also result if problems are not discovered and repaired in a timely fashion.

- Check all tire treads and sidewalls for cuts, cracks, punctures and unusual wear.
- Check each wheel for damage and cracked welds.
- Check each lug nut for proper torque to ensure none are loose.

Refer to [Table 2.4](#) for tire/wheel specifications.

2.8-8 Manuals

Ensure a copy of operating manual, EC declaration and other important documents are enclosed in manual storage box.

- Check to be sure manual storage box is present and in good condition.
- Ensure manuals are legible and in good condition.
- Always return manuals to the manual storage box after use.

2.8-9 Platform Assembly

- Ensure there are no loose or missing parts and there is no visible damage.
- Ensure all fasteners are securely in place.
- Ensure all railings are properly positioned and secured.
- Ensure gate is in good working order.
- Ensure footswitch is in good working order and has not been modified, disabled or blocked.

2.8-10 Platform Control Console

- Ensure all switches/controllers are returned to neutral and are properly secured.
- Ensure there are no loose or missing parts and there is no visible damage.

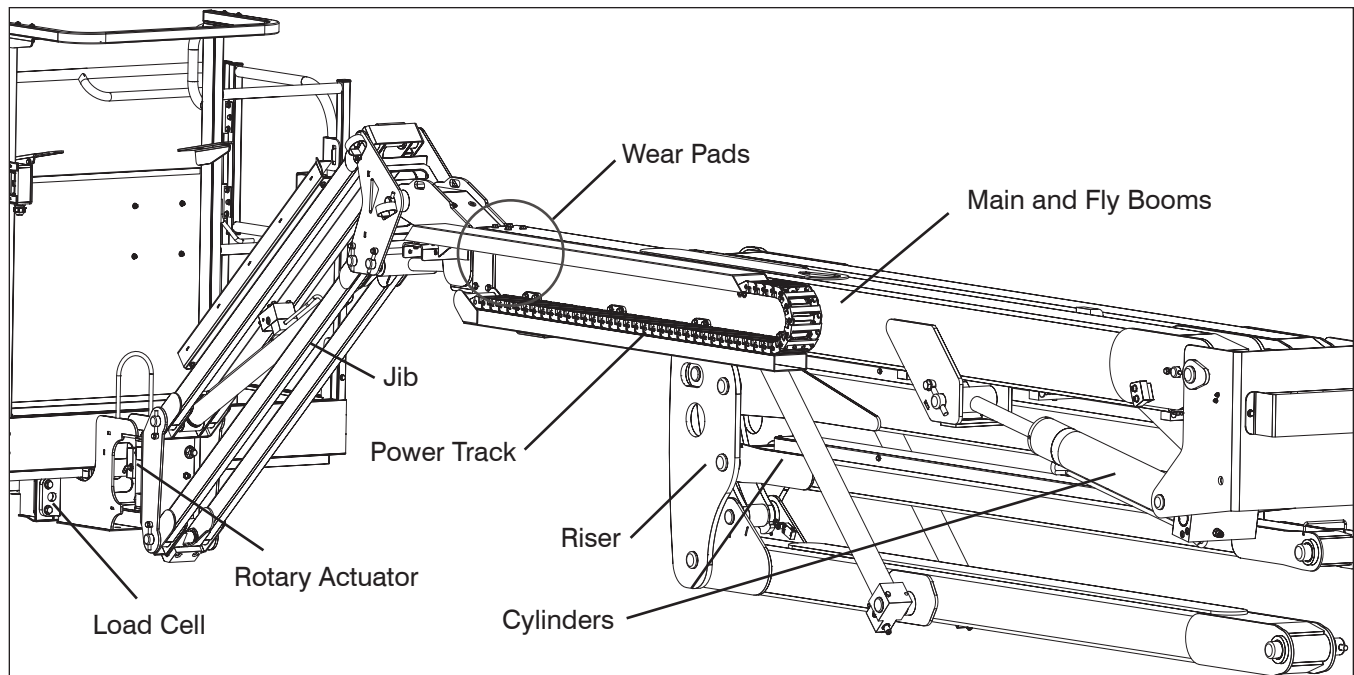

2.8-11 Rotary Actuator

- Ensure there are no loose or missing parts and there is no visible damage.
- Ensure all bolts and pins are properly tightened.
- Ensure all hoses are properly tightened and there is no evidence of hydraulic leakage.

2.8-12 Load Cell

- Ensure there are no loose or missing parts and there is no visible damage.
- Ensure all bolts are properly tightened.
- Ensure all cables are secure and are in proper working condition.
- Ensure debris is not lodged between the platform and boom adaptor.

2.8-13 Jib

- Ensure there are no loose or missing parts and there is no visible damage.
- Ensure all bolts and pins are properly tightened.
- Ensure all hoses are properly tightened and there is no evidence of hydraulic leakage.

2.8-14 Boom

- Ensure there are no loose or missing parts and there is no visible damage.
- Ensure all bolts and pins are properly tightened.
- Ensure there are no visible cracks in welds or structure and there are no signs of deformation.
- Ensure all hoses are properly tightened and there is no evidence of hydraulic leakage.
- **Cylinders**
 - Ensure all cylinders are properly secured and there is no evidence of leakage.
- **Wear Pads**
 - Ensure all bolts are tight, there is no visible damage to the wear pads and that no parts are missing.
- **Hoses**
 - Ensure all hoses are properly tightened and there is no evidence of hydraulic leakage.
- **Power Track**
 - Ensure there are no loose or missing parts and there is no visible damage.

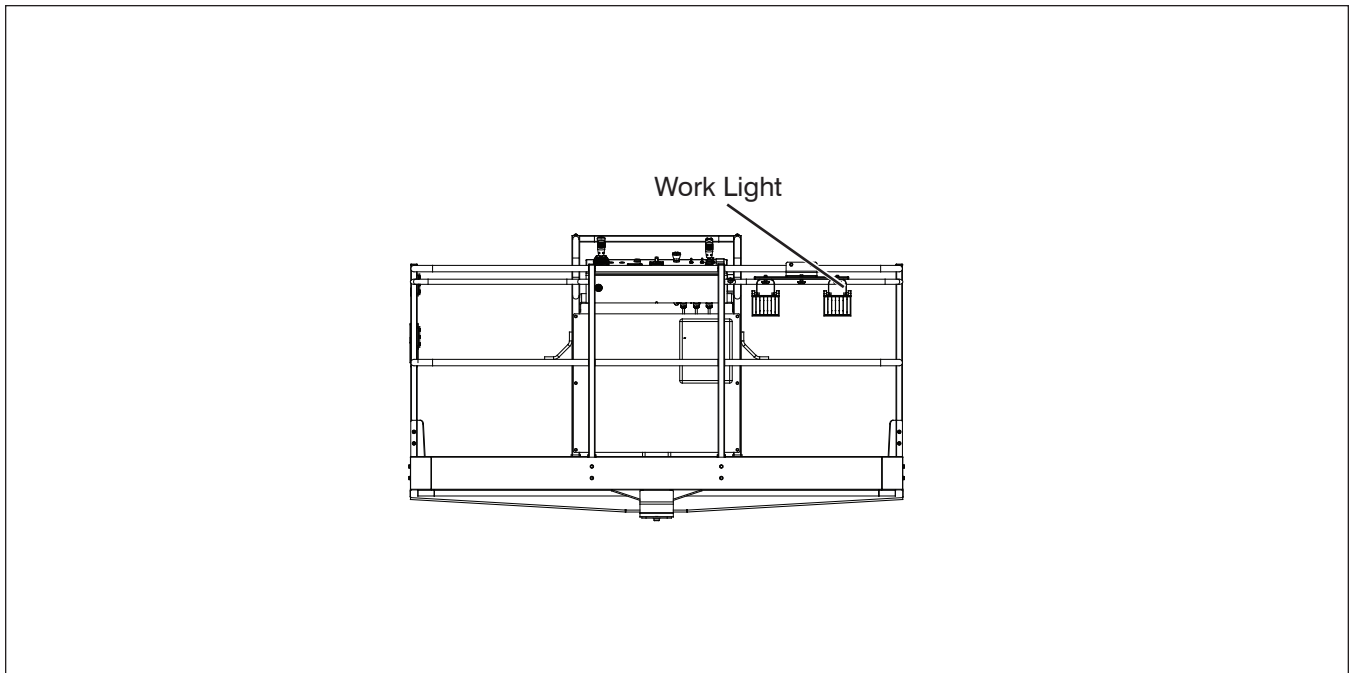

2.8-15 Special Options

- **Battery Warmer/Hydraulic Oil Heater (If Equipped)**
 - Ensure battery warmer/hydraulic oil heater cord is properly secured with no signs of visible damage and hydraulic leakage.
- **Flashing Amber Light (If Equipped)**
 - Ensure lamp is properly secured with no signs of visible damage.

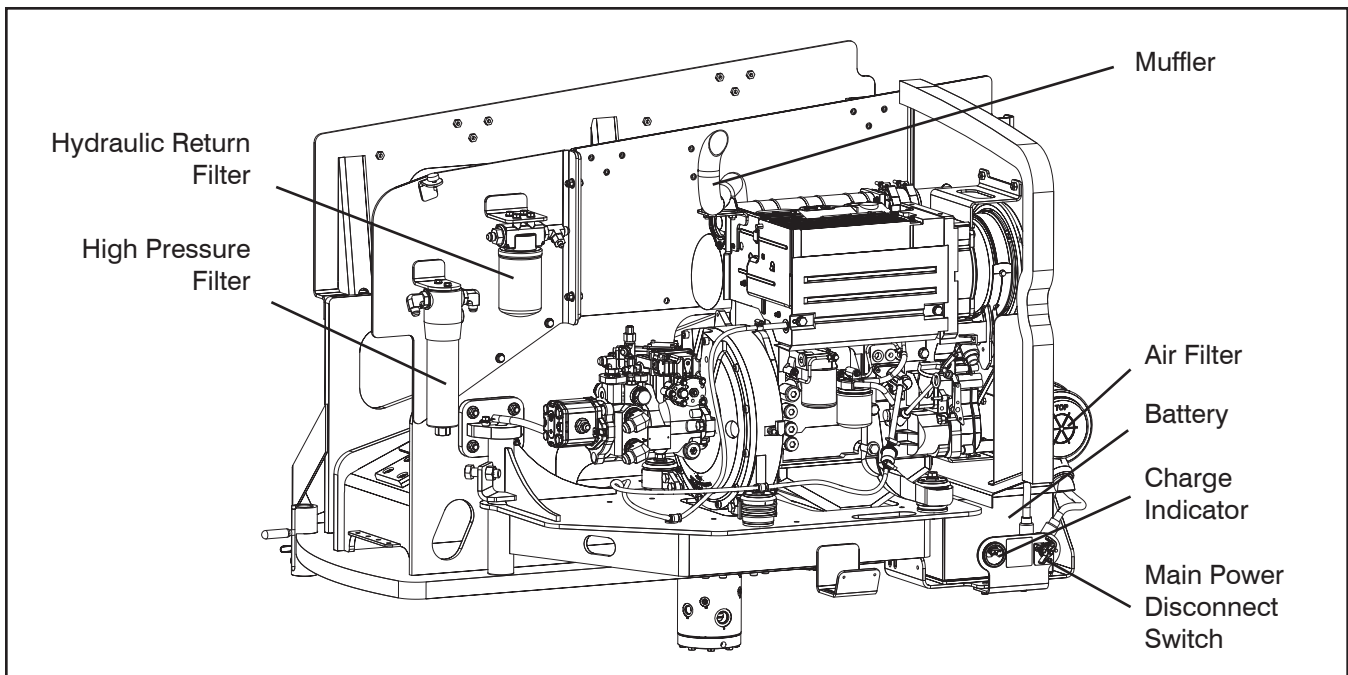

2.9 Function Tests

Function tests are designed to discover any malfunctions before aerial platform is put into service. The operator must understand and follow step-by-step instructions to test all aerial platform functions.

IMPORTANT

Never use a malfunctioning aerial platform. If malfunctions are discovered, aerial platform must be tagged and placed out of service. Repairs to aerial platform may only be made by a qualified service technician.

After repairs are completed, operator must perform a pre-operation inspection and a series of function tests again before putting aerial platform into service.

Prior to performing function tests, be sure to read and understand [Section 2.10 - Start Operation](#).



CAUTION

Allow engine to warm up for a few minutes at low speed before applying any load.



WARNING

Cold Weather - Caution must be exercised when operating aerial platform in cold temperature. Cold temperature can affect the performance of the aerial platform. Braking response and other functions may delay. Throughout the following procedures, test all functions several times until they are at acceptable operating performance.

NOTE

All-function motion alarm should sound while operating any boom and drive function.

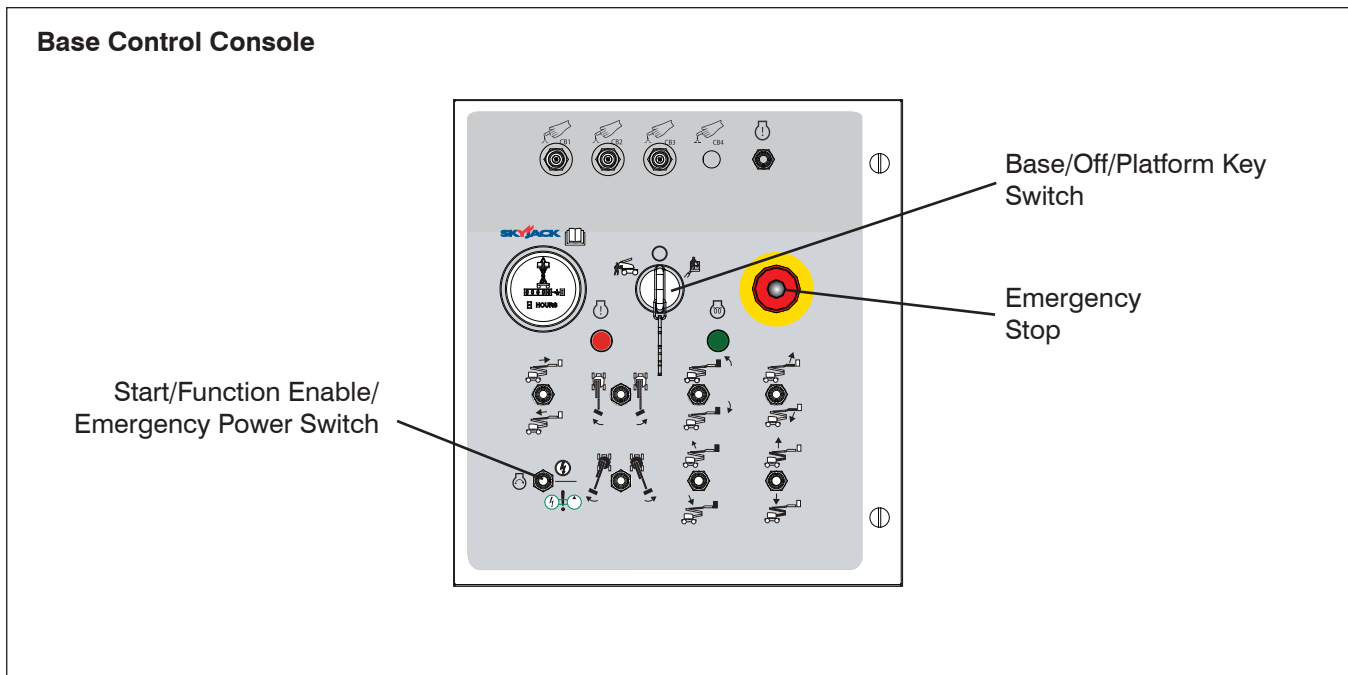

2.9-1 Test Main Power Disconnect Switch

1. In engine compartment, turn main power disconnect switch to “○” off position.
Result: Aerial platform functions should not operate.

2.9-2 Test Charge Indicator

1. In engine compartment, turn main power disconnect switch to “↑” on position.
Result: Charge indicator needle should move and stay within the green area.

Charge Indicator Levels

Green: This means that battery is adequately charged. No action required. This also indicates that charging system is working properly.

Yellow or Red: This indicates undercharge status. If charge indicator level is reasonably within yellow or red area, start engine and recharge battery before using any elevating function. After recharging battery for 15 - 30 minutes, turn engine off and ensure charge indicator needle is now in green area.



WARNING

If charge indicator needle is still within yellow or red area, inspect battery and charging system for fault, and do not elevate boom because emergency lowering system may not function properly.

NOTE

Close all cowlings before proceeding to next item.

2.9-3 Base Control Console

1. On platform control console, pull out “●” emergency stop button.



WARNING

Ensure that you maintain three points of contact to mount/dismount platform.

• Test Base Emergency Stop Light

1. On base control console, pull out “●” emergency stop button.
Result: Emergency stop light should continuously illuminate. Glow plug light should turn on and turn off after a slight delay.
2. Turn base/off/platform key switch to “🚧” base position.
3. Start engine by selecting “🌀” start position from start/function enable/emergency power switch.

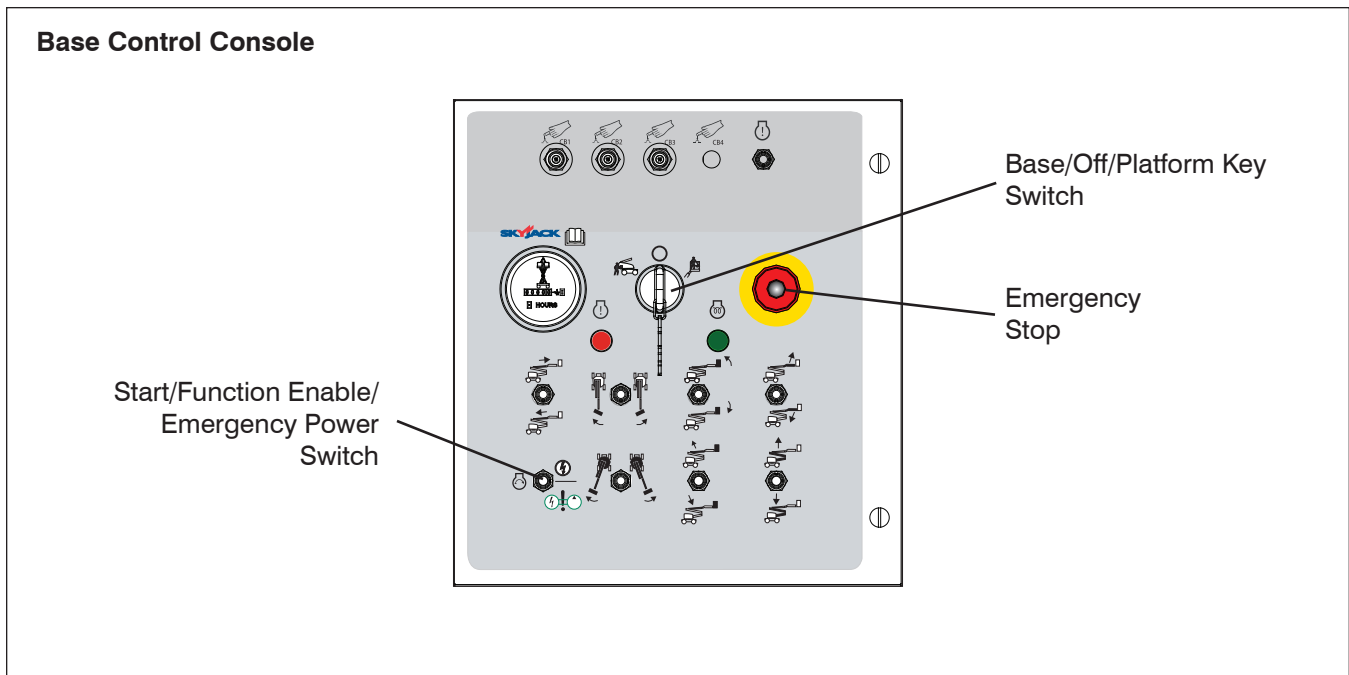

• **Test Base Emergency Stop**

1. Push in “

• **Test Function Enable Switch and All Boom Functions**



WARNING
Ensure that there are no personnel or obstructions in test area and there is sufficient room for boom to swing.

1. Do not hold “

• **Test Platform Self-leveling**

1. Lower boom to stowed position.
2. Adjust platform to a level position using platform leveling switch.
3. Raise “



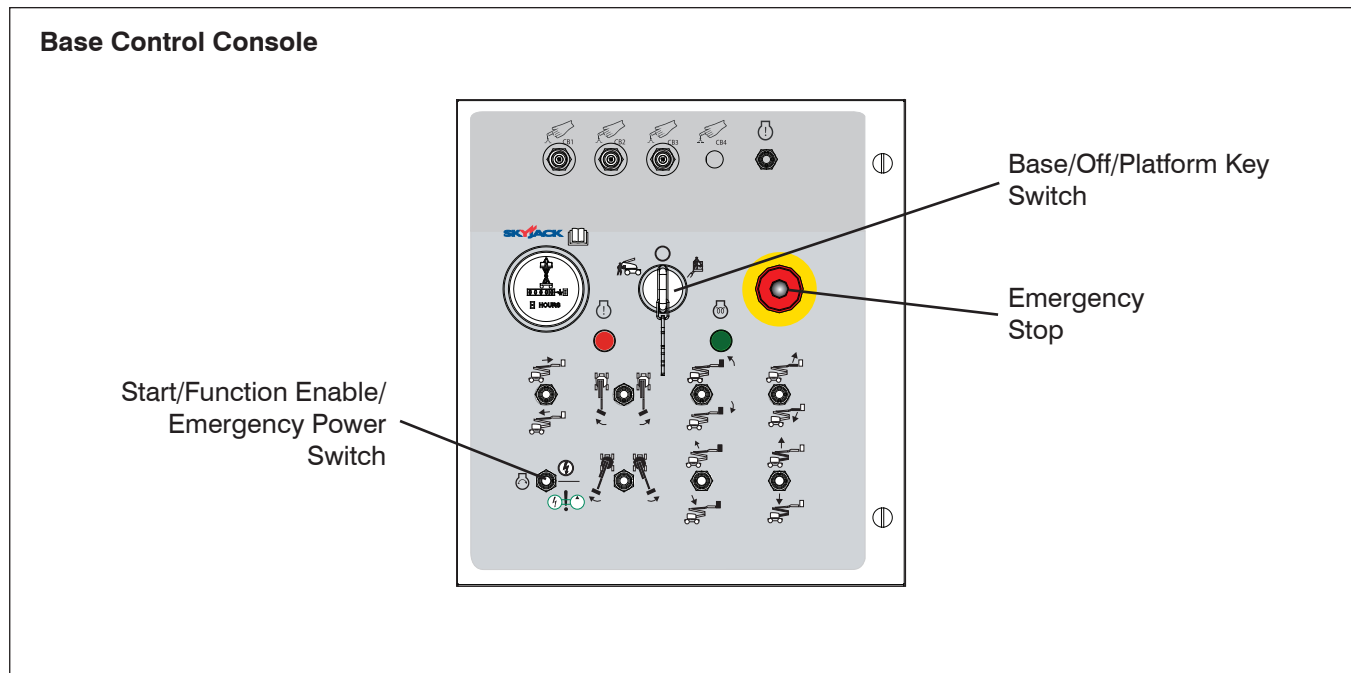

• **Test Emergency Power**

1. On base control console, push in “

CAUTION
When operating on auxiliary power, do not operate more than one function at a time to avoid overloading 12-Volt auxiliary pump motor. Do not use emergency power unit continuously for more than two minutes.

**NOTE**



To conserve battery power, test each function through a partial cycle.

3. On base control console, pull out “” emergency stop button.
4. On base control console, turn base/off/platform key switch to “” platform position.
5. Select “” emergency power position from start/function enable/emergency power switch and activate each boom function.
Result: All selected functions should operate.
6. Turn base/off/platform key switch to “” base position.
7. Select “” emergency power position from start/function enable/emergency power switch and activate each boom function.
Result: All selected functions should operate.

NOTE

The emergency power unit has two-minute duty cycle.

- **Test Base/Off/Platform Switch**



1. Ensure both “” emergency stop buttons are pulled out.
Result: Glow plug light should turn on and turn off after a slight delay.
2. Start engine.
3. On base control console, turn base/off/platform key switch to “” off position.
Result: Engine should shut down and aerial platform functions should not operate.
4. On base control console, turn base/off/platform key switch to “” platform position.

**WARNING**

Ensure that you maintain three points of contact to mount/dismount platform.

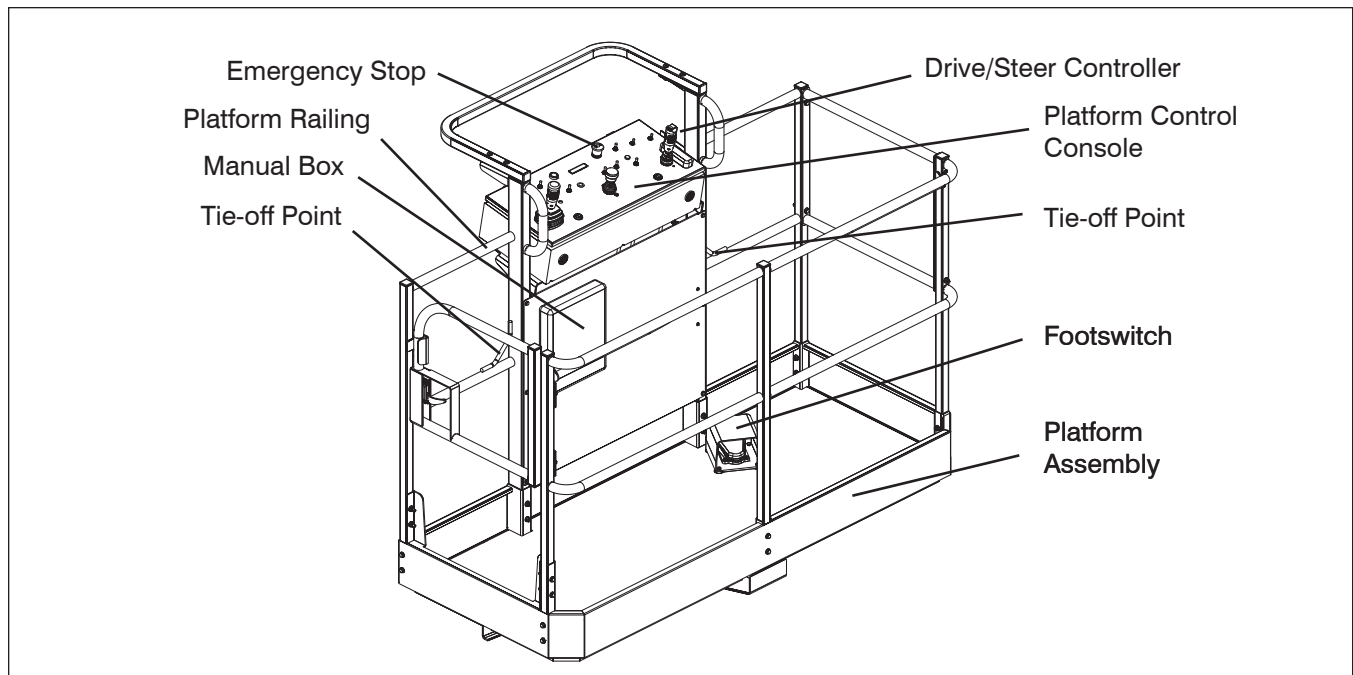
5. Enter platform and close gate.
6. On platform control console, select “” on position from engine enable switch.



7. Select “” start position from engine start/on/off switch to start engine.
8. Dismount from platform.
9. On base control console, attempt to activate each boom and platform switch while holding function enable switch.
Result: All boom and platform functions should not operate while holding function enable switch.
10. Push in “” emergency stop button to turn engine off.
11. Pull out “” emergency stop button.

2.9-4 Platform Control Console



WARNING

Ensure that you maintain three points of contact to mount/dismount platform.

1. Enter platform and close gate.



WARNING

DO NOT operate any control on platform control console without proper fall protection secured to designated location in platform. Failure to avoid this hazard could result in death or serious injury!



WARNING



Ensure that there are no personnel or obstructions in test area and that there is sufficient room for boom to swing.

• **Test Platform Emergency Stop Light**

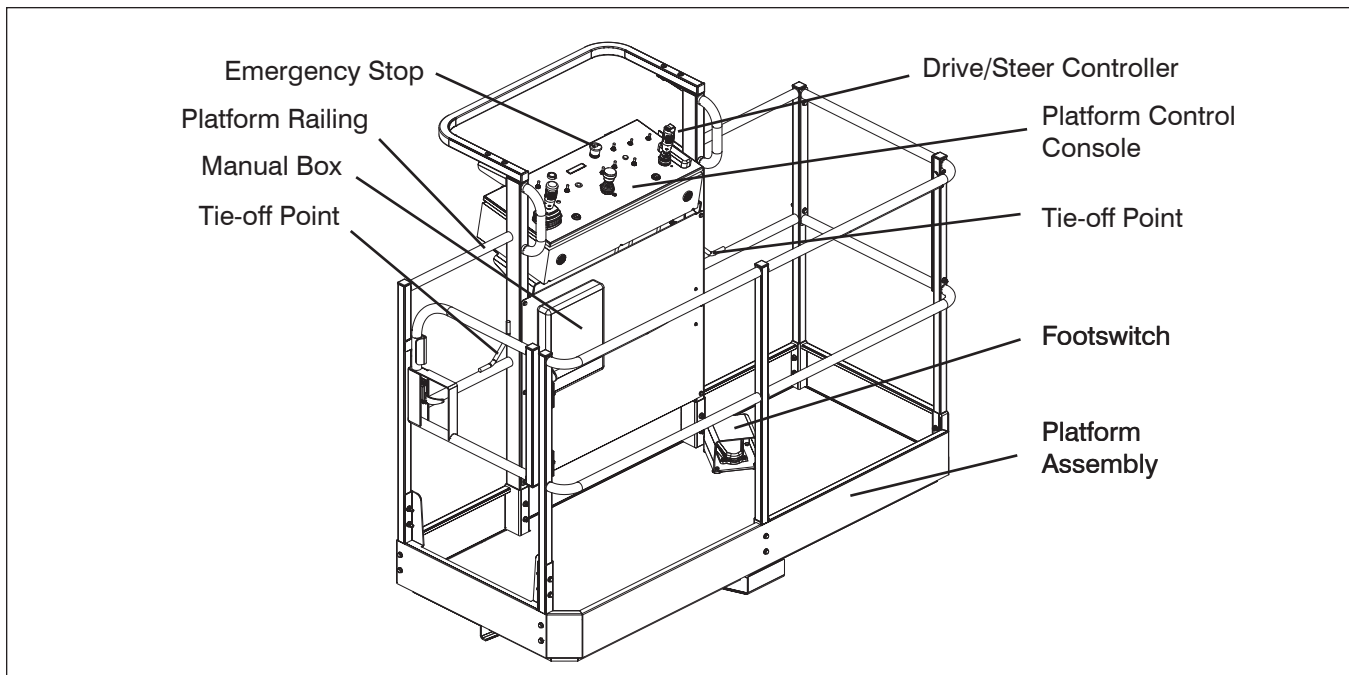

1. On platform control console, pull out “” emergency stop button.
Result: Emergency stop light should continuously illuminate.



- **Test Platform Emergency Stop**

1. Start engine by selecting “” start position from engine start/on/off switch.
Result: Engine should start.
2. Push in “” emergency stop button.
Result: Engine should shut down and aerial platform functions should not operate.

- **Test Footswitch**



1. Pull out “” emergency stop button.
2. Ensure engine enable switch is in “” on position.
3. Do not start engine.
4. Select generator on/off switch to off position (if equipped).
5. Depress and hold footswitch and attempt to start engine by selecting “” start position from engine start/on/off switch.
Result: Engine should not start.
6. Without depressing footswitch, try to start engine.
Result: Engine should start.

7. With engine running and without depressing footswitch, test each boom and platform function.
Result: Aerial platform functions should not operate.

NOTE



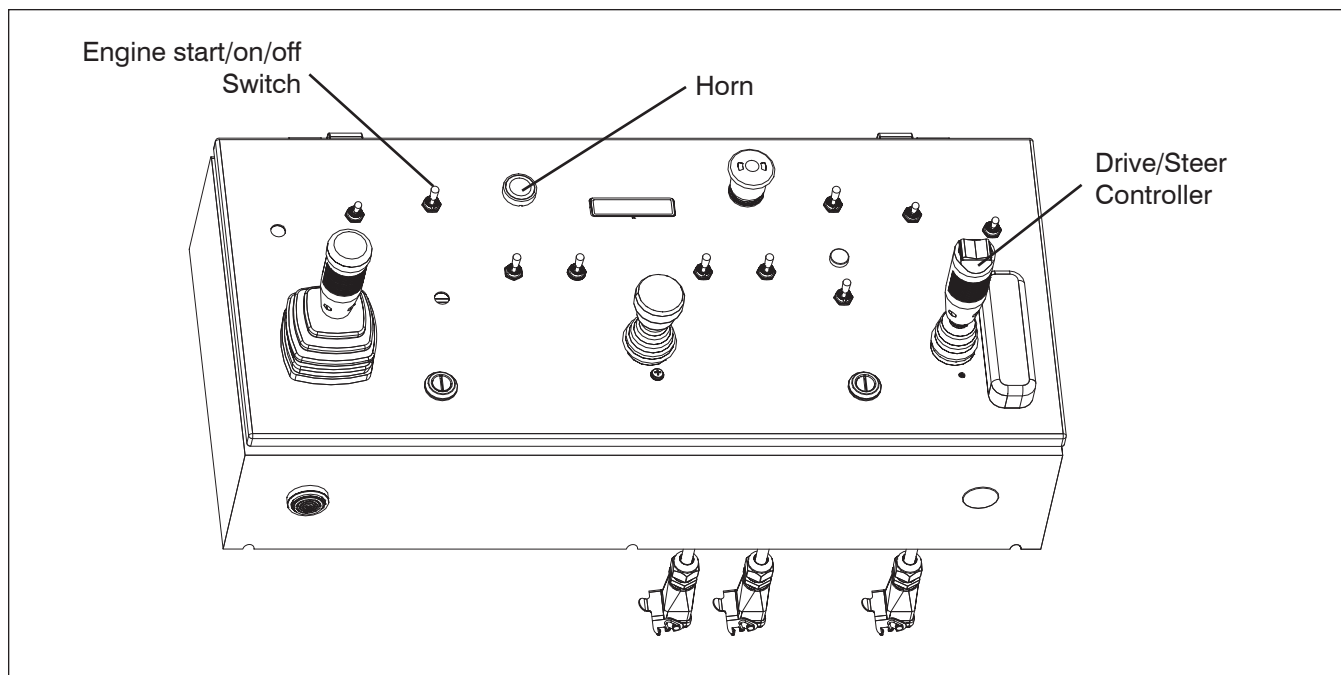

A 15-second anti-tiedown feature deactivates footswitch when operator depresses it for 15 seconds without activating any function.

- **Test Engine Enable Switch**

1. Ensure engine is running.
2. Select “” off position from engine enable switch.
Result: Engine should shut down and platform control console is disabled.
3. Select “” on position from engine enable switch.
Result: Platform control console is enabled.
4. Start engine.



• **Test Steering**

1. Pull out “” emergency stop button.
2. Start engine by selecting “” start position from engine start/on/off switch.
3. Depress and hold footswitch.
4. Press rocker switch on top of drive/steer controller to “” left and “” right.
Result: Steer wheels should turn left and right.



Result: Aerial platform should move in forward or reverse direction, and then come to a stop.

 **WARNING**
DRIVING ON A SLOPE

- When driving on a slope greater than 30%, the platform capacity is limited to 136 kg (300 lb.).
- The platform must be between the non-steer wheels and must be on the downside of the hill.
- When slope increases to above 45%, the forward drive is disabled but reverse drive remains active.





• **Test Driving Function**

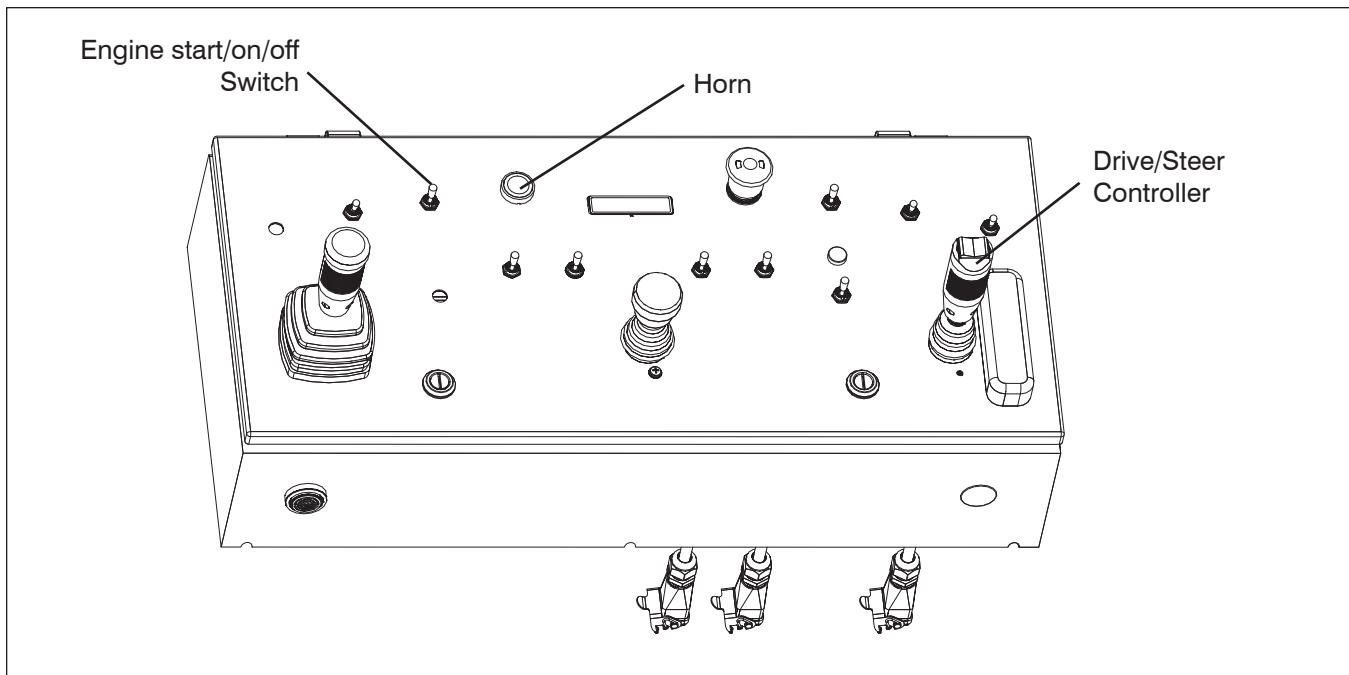

1. Ensure path of intended motion is clear.
2. Ensure boom is in stowed position and fly boom fully retracted.
3. Depress and hold footswitch.
4. Slowly move drive/steer controller in “” forward or “” reverse direction until aerial platform begins to move, and then return handle to center position.



- **Test Driving Speed**

1. Depress and hold footswitch.
2. Raise “” main boom 1.2 m (4 ft.) above ground and then slowly move drive/steer controller to full drive position.
Result: The maximum achievable drive speed should be significantly less than stowed drive speed.
3. Lower boom to stowed position.
4. Extend “” fly boom approximately 30 cm (12 inch.) and then slowly move drive/steer controller to full drive position.
Result: The maximum achievable drive speed should be significantly less than stowed drive speed.
5. Retract fly boom.
6. Raise riser approximately 1.2 m (4 ft.) above ground.
Result: The maximum achievable drive speed should be significantly less than stowed drive speed.

- **Test Load Sensing System**

1. Push in “” emergency stop button.
2. Pull out “” emergency stop button.
Result: After four seconds of time elapses, the red light and audible alarm pulse two times. This indicates the system is active and there are no faults.

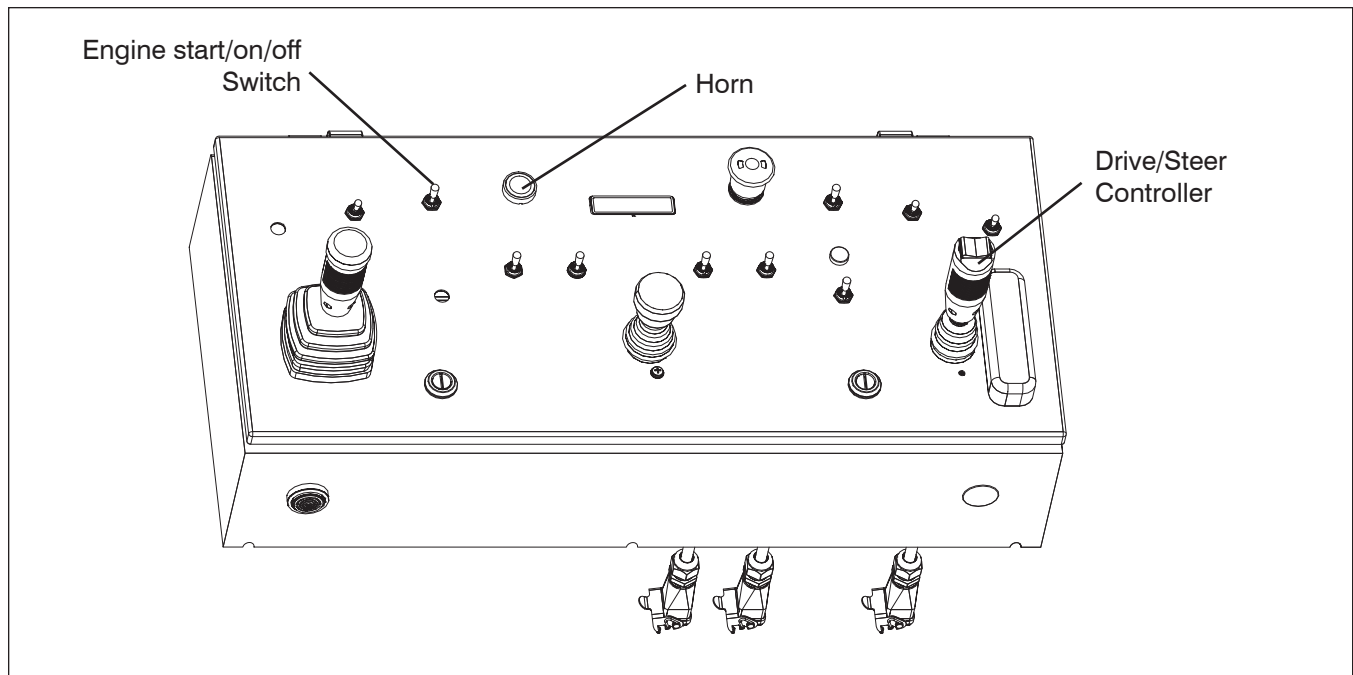



• **Test Emergency Power**



When operating on auxiliary power, do not operate more than one function at a time to avoid overloading 12-Volt auxiliary pump motor. Do not use emergency power unit continuously for more than two minutes.

NOTE

To conserve battery power, test each function through a partial cycle.

1. On platform control console, push in “” emergency stop button to turn engine off.
2. Pull out “” emergency stop button.
3. Select “” on position from engine enable switch.
4. Depress and hold footswitch.

5. Push and hold “” emergency power switch and activate each function control handle or switch.

Result: All boom and steer functions should operate. Drive functions should not operate.

NOTE

The emergency power unit has two-minute duty cycle.

• **Test Horn**

1. Push “” horn pushbutton.
- Result:** Horn should sound.

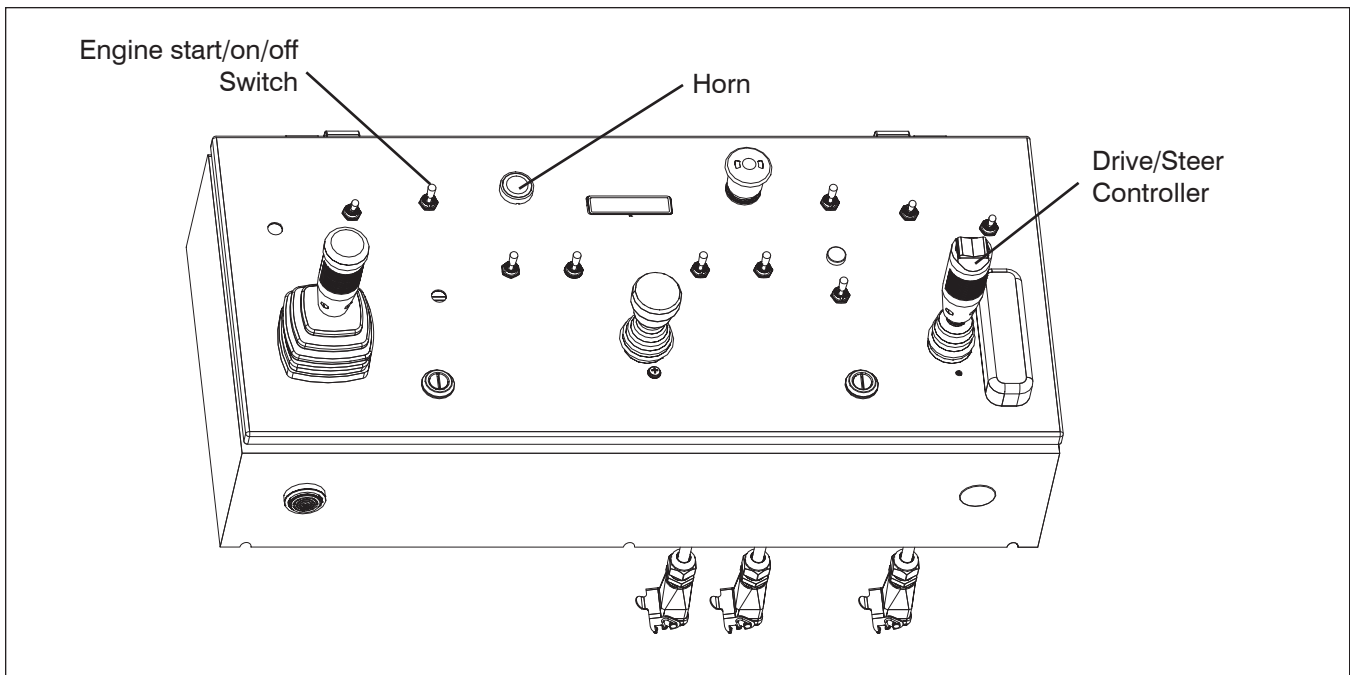



• **Test Brakes**





WARNING

Brakes will engage instantly when you release footswitch, causing aerial platform to stop immediately.

1. Restart engine.
2. Move aerial platform to a firm level surface to ensure similar traction on left and right.
3. Ensure boom is in stowed position.
4. Depress and hold footswitch and drive aerial platform first “” forward then “” reverse.

5. Remove your foot from footswitch.
Result: Aerial platform should come to an abrupt stop. If aerial platform does not stop immediately, or if aerial platform pulls to one side while stopping, do not operate aerial platform until brake adjustments have been checked.

• **Test Manual Platform Leveling**

1. Depress and hold footswitch.
2. On platform leveling override switch, pull and select “” up position to tilt platform up or “” down position to tilt platform down.

Result: Platform should tilt up or down.

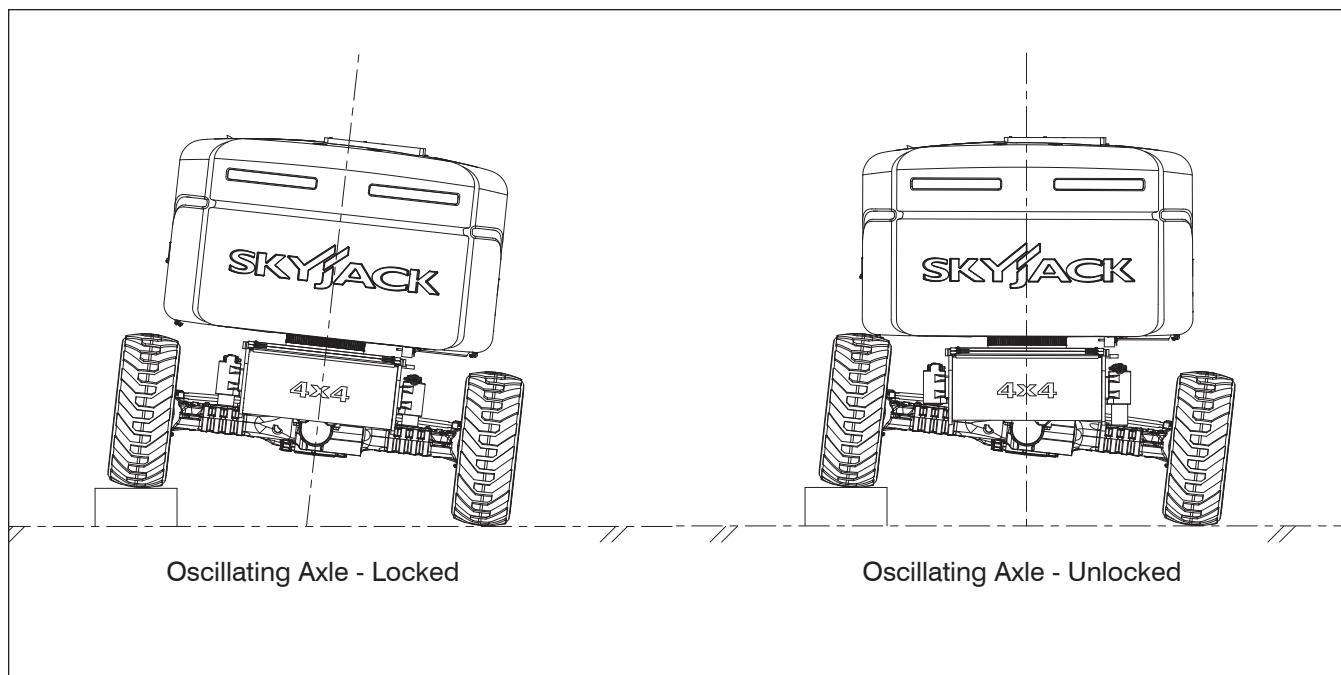



• Test Differential Lock Switch



WARNING

Before engaging differential lock, ensure drive/steer controller is in neutral position.

1. On platform control console, push differential lock switch forward  to the locked position and then release.
Result: Differential lock is engaged and differential light should turn on.
2. Pull differential lock switch backward  to the unlocked position and then release.
Result: Differential lock is disengaged and differential light should turn off.

• Test Oscillating Axles



WARNING

DO NOT operate any control on platform control console without proper fall protection secured to designated location in platform. Failure to avoid this hazard could result in death or serious injury!

1. Extend fly boom 30 cm (12 in.) while on a firm level ground.
Result: The steer axles should be locked.
2. Drive one of the steer tires up onto a 15 cm (6 in.) block or curb.
Result: An appropriate tilt of the aerial platform chassis should occur.
3. Retract fly boom while in tilt position.
Result: The steer axles should unlock and the aerial platform chassis should level itself to ground.

2.10 Start Operation

Carefully read and completely understand the Operating Manual and all warnings and instruction labels (refer to labels section) on the aerial platform.



WARNING

DO NOT operate this aerial platform without proper authorization and training. Failure to avoid this hazard could result in death or serious injury.

Before operating this aerial platform, perform the following steps:

1. Visual and daily maintenance inspections (see [Section 2.8](#))
2. Function tests (see [Section 2.9](#))
3. Jobsite inspection
It is the responsibility of the operator to perform a jobsite inspection and avoid the following hazardous situations:
 - holes or drop-offs
 - ditches or soft fills
 - floor obstructions, bumps or debris
 - overhead obstructions
 - electrical cords, hoses and high voltage conductors
 - hazardous locations
 - inadequate surface support to withstand all load forces imposed by the aerial platform
 - wind and weather conditions
 - the presence of unauthorized personnel
 - other possible unsafe conditions



WARNING

An operator should not use any aerial platform that:

- does not appear to be working properly.
- has been damaged or appears to have worn or missing parts.
- has alterations or modifications not approved by the manufacturer.
- has safety devices which have been altered or disabled.
- has been tagged or locked out for non-use or repair.





Failure to avoid these hazards could result in death or serious injury.

2.10-1 To Activate Base Control Console



WARNING

Ensure that you maintain three points of contact to mount/dismount the platform.

1. Enter platform and close gate.
2. On platform control console, pull out “” emergency stop button.
3. In engine compartment, turn main power disconnect switch to “I” on position.
4. On base control console, turn base/off/platform key switch to “” base position.
5. Pull out “” emergency stop button.
6. Select “” start position from start/function enable/emergency power switch until engine starts.



WARNING



DO NOT over crank the starter. If engine fails to start after multiple attempts, consult “Troubleshooting Information,” in the Service and Maintenance Manual.



CAUTION

Allow engine to warm up for a few minutes at low speed before applying any load.

2.10-2 To Rotate Platform Using Base Control Console



1. Activate and hold function enable switch “” by pushing it to the right.
2. Push platform rotation switch to either “” left or “” right position. Release switch to stop.

2.10-3 To Rotate Turret Using Base Control Console



WARNING



When rotating the turret, ensure that there are no personnel or obstructions in the path of rotation, including blind spots.

1. Activate and hold function enable switch “” by pushing it to the right.
2. Push turret rotation switch to either “” clockwise or “” counterclockwise position. Release switch to stop.



NOTE

Turret can be rotated continuously 360 degrees.



2.10-4 To Move Jib Up and Down Using Base Control Console

1. Activate and hold function enable switch “” by pushing it to the right.
2. Push jib up/down switch to either “” up or “” down position. Release switch to stop.



2.10-5 To Move Riser Up and Down Using Base Control Console

1. Activate and hold function enable switch “” by pushing it to the right.
2. Push riser up/down switch to either “” up or “” down position. Release switch to stop.



2.10-6 To Raise or Lower Main Boom Using Base Control Console

1. Activate and hold function enable switch “” by pushing it to the right.
2. Push main boom raise/lower switch to either “” raise or “” lower position. Release switch to stop.

2.10-7 To Extend or Retract Fly Boom Using Base Control Console

1. Activate and hold function enable switch “” by pushing it to the right.
2. Push fly boom extend/retract switch to either “” extend or “” retract position. Release switch to stop.

2.10-8 To Level Platform Manually Using Base Control Console

1. Activate and hold function enable switch “” by pushing it to the right.
2. Push platform leveling override switch to either “” up or “” down position. Release switch to stop.

2.10-9 To Operate Using Emergency Power Switch at Base Control Console

This is a momentary-type switch. This switch allows all functions except the drive function to operate in the event of engine malfunction. Refer to [Section 2.14](#) for the emergency lowering procedure.

NOTE



The emergency power unit has two-minute duty cycle.



CAUTION

Do not use emergency power unit continuously for more than two minutes.

2.10-10 To Activate Platform Control Console

1. In engine compartment, turn main power disconnect switch to “I” on position.
2. On base control console, turn base/off/platform key switch to “” platform position.
3. On base control console, pull out “” emergency stop button.



WARNING

Ensure that you maintain three points of contact to mount/dismount the platform.



WARNING

DO NOT operate any control on operator’s control console without proper fall protection secured to the designated location in the platform. Failure to avoid this hazard could result in death or serious injury.

4. Enter platform and close gate.
5. Attach body harness lanyards of each occupant to platform lanyard rings.
6. On platform control console, pull out “” emergency stop button.

7. Push and hold “” start position from start/on/off switch until engine starts.





WARNING

DO NOT over crank the starter. If engine fails to start after multiple attempts, consult “Troubleshooting Information,” in the Service and Maintenance Manual.

NOTE

Engine will not start if you are pressing down on the footswitch.

8. Select desired engine RPM using throttle switch: “” high or “” low.



WARNING

- **DO NOT drive or steer the aerial platform when the platform position does not allow you a clear view of the base.**
- **Your area of operation should be cordoned from other personnel or equipment.**

2.10-11 To Drive Forward or Reverse





WARNING

- When climbing high grades:
 - all booms must be fully stowed.
 - restrict platform capacity to 300 lbs.



CAUTION

When you are in the platform and positioned over an axle, the direction you are facing will be forward.

1. Depress and hold footswitch.
2. Push and hold drive/steer controller in this direction “” to drive forward or “” to drive backward.
3. Release controller handle to stop.



DANGER

The drive orientation can change when the turret is swung 90 degrees off center of the normal driving position (roughly when boom is swung past the rear tire). Drive re-orientation will not occur while driving and rotating until the joystick is released for 6 seconds or when the footswitch is released.





WARNING

DRIVING ON A SLOPE



- When driving on a slope greater than 30%, the platform capacity is limited to 136 kg (300 lb.).
- The platform must be between the non-steer wheels and must be on the downside of the hill.
- When slope increases to above 45%, the forward drive is disabled but reverse drive remains active.



2.10-12 To Steer

1. Depress and hold footswitch.
2. Press rocker on top of drive/steer controller in this direction “” to steer left or “” to steer right.



NOTE

Driving and steering may be active at the same time.



2.10-13 To Move Jib Up and Down Using Platform Control Console

1. Depress and hold footswitch.
2. On jib up/down switch, select “” to move jib up or “” to move jib down. Release switch to stop.



2.10-14 To Move Riser Up and Down Using Platform Control Console

1. Depress and hold footswitch.
2. On riser up/down switch, select “” to move riser up or “” to move riser down. Release switch to stop.



2.10-15 To Extend or Retract Fly Boom Using Platform Control Console

1. Depress and hold footswitch.
2. On fly boom extend/retract switch, select “” to extend fly boom or “” to retract fly boom. Release switch to stop.



2.10-16 To Rotate Platform Using Platform Control Console

1. Depress and hold footswitch.
2. On platform rotation switch, select “” to rotate platform left or “” to rotate platform right.

2.10-17 To Level Platform Manually Using Platform Control Console

1. Depress and hold footswitch.
2. On platform leveling override switch, pull and select “” up position to tilt platform up or “” down position to tilt platform down.

2.10-18 To Raise or Lower Main Boom Using Platform Control Console



1. Depress and hold footswitch.
2. Push and hold boom/turret controller in this direction “” to raise main boom or “” to lower main boom.
3. Release controller handle to stop.

2.10-19 To Sound Horn

1. Press “” horn pushbutton to sound horn. Release pushbutton to stop sounding horn.

2.10-20 To Rotate Turret Using Platform Control Console**WARNING**

When rotating the turret, ensure that there are no personnel or obstructions in the path of rotation, including blind spots.

1. Depress and hold footswitch.
2. Push and hold boom/turret controller in this direction “” to rotate clockwise or “” to rotate counterclockwise.
3. Release controller handle to stop.

NOTE

Turret can be rotated continuously 360 degrees.

2.10-21 To Operate Using Emergency Power Switch at Platform Control Console

This is a momentary-type switch. This switch allows all functions except drive function to operate in the event of engine malfunction. Refer to [Section 2.14](#) for the emergency lowering procedure.



NOTE

The emergency power unit has two-minute duty cycle.

**CAUTION**

Do not use emergency power unit continuously for more than two minutes.

2.10-22 Shutdown Procedure

1. Completely retract boom and lower platform.
2. Push in “” emergency stop button on platform control console and on base control console.
3. Turn base/off/platform key switch to “” off position. Remove key.
4. Turn main power disconnect switch to “” off position.

For aerial platform with cold weather start option:

NOTE

When temperature gets below -11°C (+11°F), ensure aerial platform is parked close to AC outlet.

5. Plug in battery warmer/hydraulic oil heater into AC outlet at least 4 hours before starting engine.

2.10-23 Hydraulic Generator (If Equipped)**To start hydraulic generator:**

1. Ensure engine is running.
2. On platform control console, turn generator on/off switch to “” on position.

To restore normal operation:

1. On platform control console, turn generator on/off switch to “” off position.

NOTE

An engine shut down will turn the generator off. Normal boom functions are disabled while the generator is on.

2.11 Refueling Procedure

This section provides the operator with procedure on how to refuel engine with regular fuel.

IMPORTANT

Before using your aerial platform ensure there is enough fuel for expected use.



WARNING

Failure to heed the following safety precautions could result in death or serious injury:

- Use extreme caution while refueling aerial platforms.
- Ensure that engine and all systems are turned off before refueling.
- Refuel the aerial platform only in a well ventilated area away from open flame and other sources of ignition, authorized by your employer and supervisor.



WARNING

Do not smoke in an area where aerial platforms are stored or refueled.

2.11-1 Regular Fuel (Diesel)

IMPORTANT

Use unleaded gasoline only.

1. Ensure engine and all systems are turned off and emergency stop buttons are depressed.
2. Open control compartment and remove fuel cap.
3. Carefully fill the fuel tank ensuring that no spillage occurs.
4. Securely replace fuel cap.
5. Ensure there are no leaks in fuel system.
6. Wipe up any spilled fuel.
7. Dispose of rags in an approved container.

2.12 Loading/Unloading

Know and heed all national, state/provincial and local rules which apply to transporting of aerial platforms.

Only qualified personnel shall operate machinery during loading/unloading.

Be sure vehicle capacity and loading equipment hoists, chains, straps, etc., are sufficient to withstand maximum aerial platform weight.

The transport vehicle must be parked on a level surface and must be secured to prevent rolling while aerial platform is being loaded or unloaded.

2.12-1 Loading and Tie-down

1. Lock turret using turret transportation lock (refer to [Section 2.12-2](#)).
2. Turn key switch to “○” off position and remove key before transporting.
3. Turn main power disconnect switch to “○” off position.
4. Chock aerial platform wheels (if necessary).
5. Remove all loose items.
6. Anchor down aerial platform to transport surface using tie-down points (refer to [Figure 2-9](#)).

7. Secure boom from side-to-side movement using lower platform mount between boom end and platform. Do not use excessive downward force when securing boom section.



WARNING

Inspect aerial platform for loose or unsecured items.

NOTE

For loading and unloading using a winch line, refer to [Section 2.13](#).



WARNING

DRIVING ON A SLOPE

- When driving on a slope greater than 30%, the platform capacity is limited to 136 kg (300 lb.).
- The platform must be between the non-steer wheels and must be on the downside of the hill.
- When slope increases to above 45%, the forward drive is disabled but reverse drive remains active.

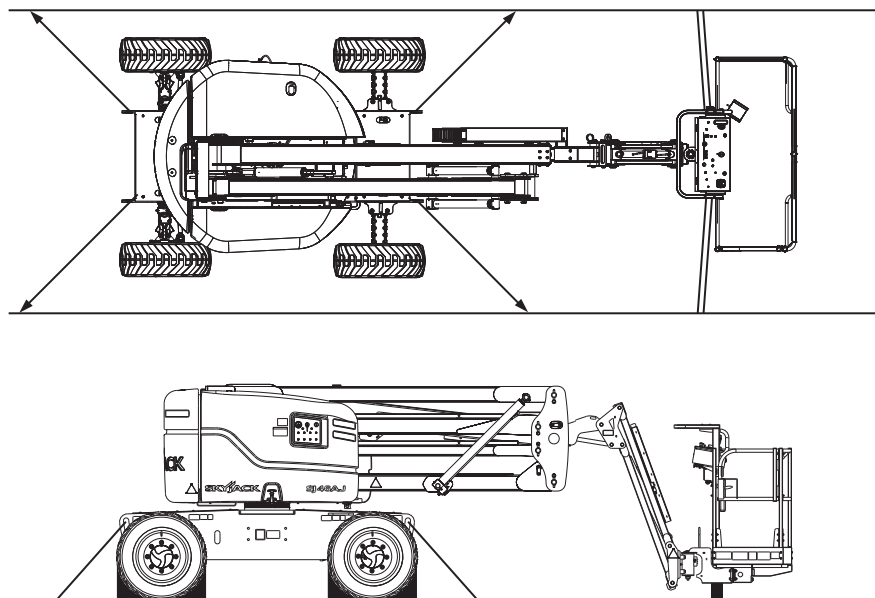

Figure 2-9. Tie-down Points

2.12-2 Locking the Turret

1. Ensure that turret is positioned so that turret transportation lock tube (item 1 - Figure 2-10) is aligned into one of two turret locking points in the turret rotation lock plate.
2. Pull out turret lock retaining pin (item 2 - Figure 2-10). Lower turret lock into locked position and reinsert turret lock retaining pin.



WARNING

Use chains of ample load capacity sufficient to withstand aerial platform weight.

1. Place boom in stowed position centered between drive wheels. Lock turret using turret transportation locking pin (refer to Section 2.12-2) into the transport point (refer to Figure 2-10).
2. Turn main power disconnect switch to “○” off position.
3. Remove all loose items from aerial platform.
4. Properly adjust rigging to prevent damage to aerial platform and so aerial platform remains level.

2.12-3 Lifting

NOTE

When it becomes necessary to lift aerial platform, it is very important that lifting devices are attached only to designated lifting points (refer to Figure 2-11).

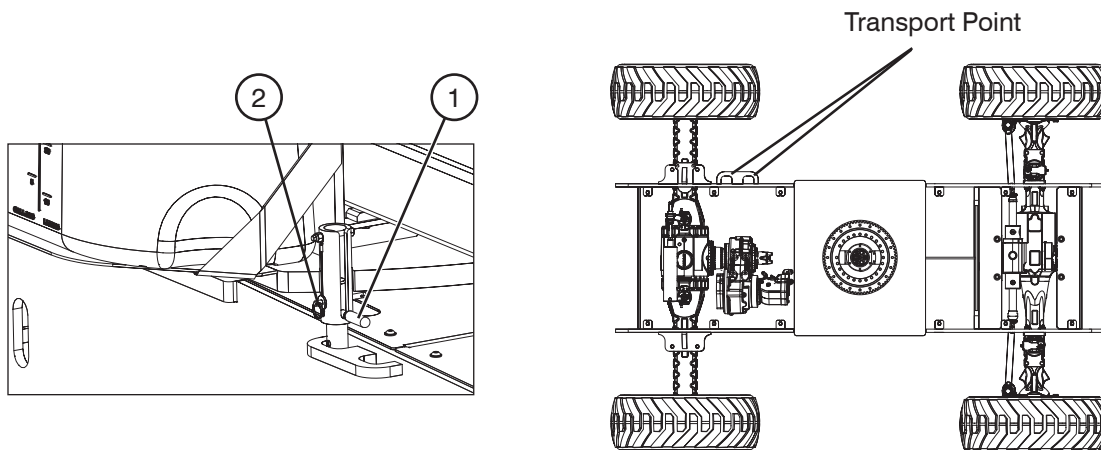

Figure 2-10. Turret Transportation Lock & Locking Points

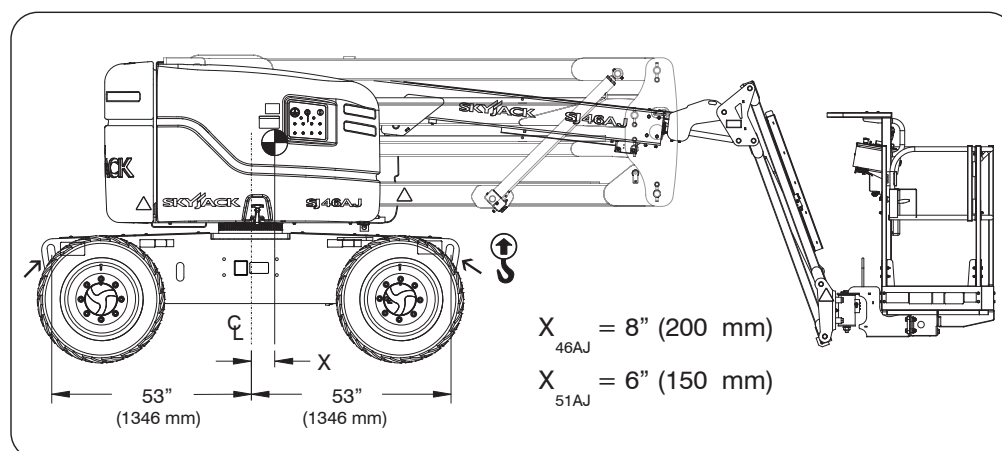

Figure 2-11. Lifting Points
NOTE: Center of gravity varies with different options.

2.13 Winching and Towing Procedure

This section provides the operator with procedure about winching and towing and on how to manually release brakes.

**WARNING**

Ensure boom is in stowed position before winching or towing. Sudden motion could cause aerial platform to become unstable. Death or serious injury could result.

**WARNING**

In emergency situations where aerial platform functions are not available and lowering is impeded by an obstacle, utmost care must be taken to move aerial platform far enough to clear obstacle. In such cases, operation must be extremely smooth with no sudden movements and must not exceed a speed of 50 mm/sec (2 in./sec).

**WARNING**

When pushing, winching or towing, do not exceed 3.2 km/h (2 mph).

**WARNING**

Do not winch or tow aerial platform on grade steeper than 45% (4WD).

**WARNING**

Do not winch or tow aerial platform onto a slope, or brake the towing vehicle rapidly. Do not pull aerial platform down an incline towards a winch.

1. Before winching or towing aerial platform, fully retract, lower and position boom over rear drive wheels in line with direction of travel.
2. Manually release brakes (refer to [Section 2.13-1](#)).
3. Remove wheel chocks or blocks, and then winch or tow aerial platform to desired location.

4. Position aerial platform on a firm and level surface.
5. Chock or block wheels to prevent aerial platform from rolling.
6. Apply brakes by pulling out black brake auto reset valve.

NOTE

Brakes automatically apply when platform controls are engaged.

**WARNING**

Brakes must be applied immediately after reaching desired location.

2.13-1 To Release Brakes Manually

Brakes must be manually disengaged for winching or towing.



WARNING

Do not manually disengage brakes if aerial platform is on a slope.

1. Ensure aerial platform is on level ground. Chock or block wheels to keep aerial platform from rolling.
2. Turn main power disconnect switch to “O” off position.



CAUTION

Do not use hydraulic power with brake disengaged.

3. Locate the bypass valve on the inboard side of the drive pump. Bypass the drive pump by loosening the valve stem (item 1 - marked with yellow paint) two revolutions counterclockwise.

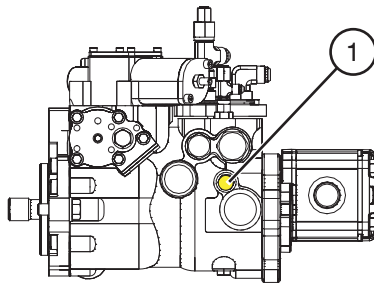

Figure 2-12. Drive Bypass Valve



CAUTION

Do not release brakes before disengaging drive motor!

4. Push in black brake valve plunger (item 2).

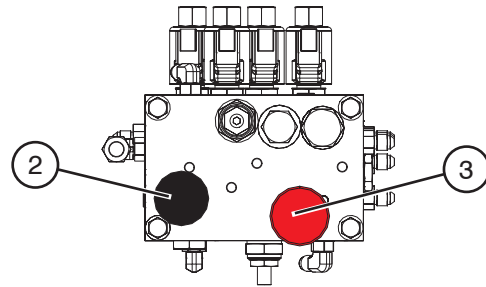

Figure 2-13. Brake Manifold

5. Actuate red hand pump (item 3) slowly by moving knob in and out until firm resistance is felt. Brake is now released.



WARNING

Brakes must be applied immediately after reaching desired location. Refer to Section 2.13 on how to reengage brakes.

2.14 Emergency Lowering Procedures

This section guides the operator on how to use emergency lowering system. This system allows platform lowering in the event of an emergency or engine malfunction.





NOTE

The emergency power unit has two-minute duty cycle.



**CAUTION**

Do not use emergency power unit continuously for more than two minutes.

At Base Control Console:

1. Ensure engine is off.
2. Pull out “” emergency stop button.
3. Select either “” base position or “” platform position from key switch.
4. Select “” emergency power position from start/function enable/emergency power switch and activate desired boom function.

At Platform Control Console:

1. Ensure engine is off.
2. Pull out “” emergency stop button.
3. Select “” on position from engine enable switch.
4. Depress and hold footswitch.
5. Select “” emergency power position from start/function enable/emergency power switch and activate desired boom function.

NOTE

When platform is overloaded in work mode, emergency lowering is only available from base controls.

2.15 Chassis Tilt

This section guides the operator with regard to recovering from an inclined position.

IMPORTANT

When the boom is raised or extended, the aerial platform must only be operated on firm level surfaces.



WARNING

When the aerial platform becomes tilted causing the alarm to sound, the platform must be fully lowered and retracted immediately. Drive functions are not available when the tilt alarm is active.

2.15-1 Platform Uphill

If the aerial platform becomes tilted with the platform uphill (refer to Figure 2-14) follow the steps below to return to a lowered and retracted position.

1. Lower main boom completely.
2. Lower riser completely.
3. Retract fly boom completely.
4. Drive to a firm level surface.

2.15-2 Platform Downhill

If the aerial platform becomes tilted with the platform downhill (refer to Figure 2-15) follow the steps below to return to a lowered and retracted position.

1. Retract fly boom completely.
2. Lower riser completely.
3. Lower main boom completely.
4. Drive to a firm level surface.

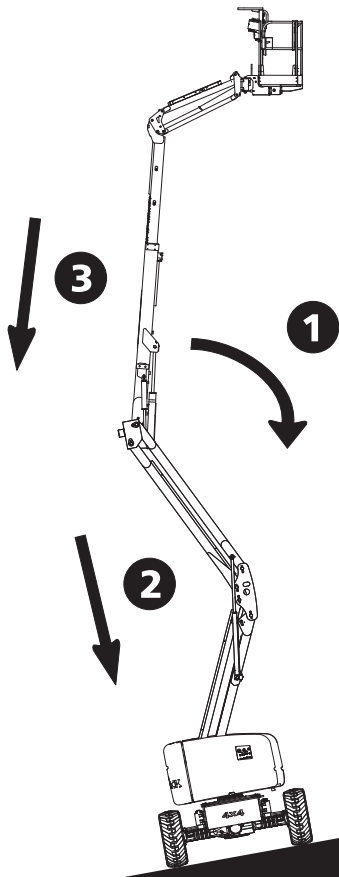

Figure 2-14. Platform Uphill

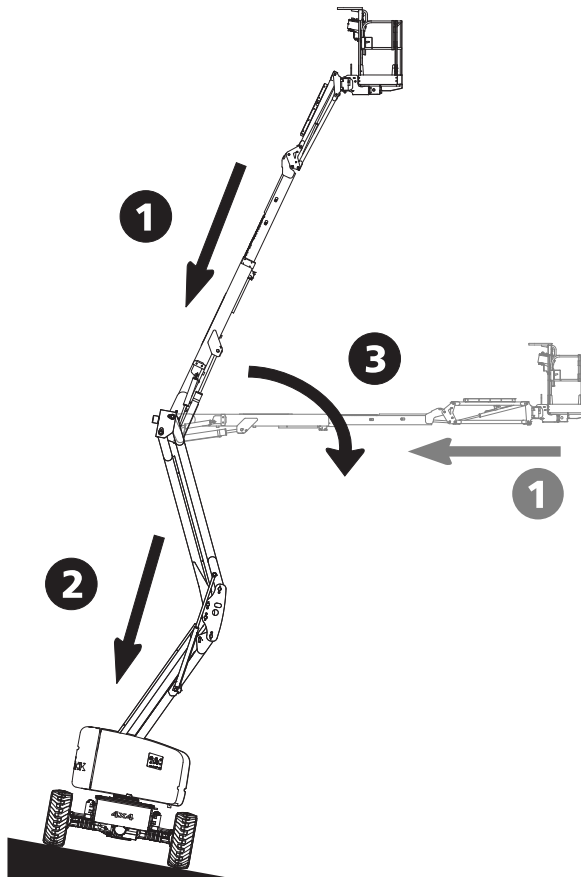

Figure 2-15. Platform Downhill

Diagram 2.2 Dimension and Reach Diagram - SJ 51AJ

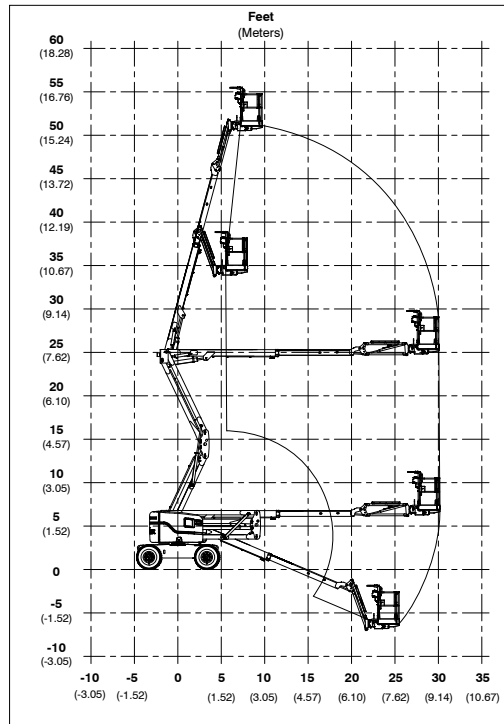

Figure 2-18. Reach Diagram - 51AJ

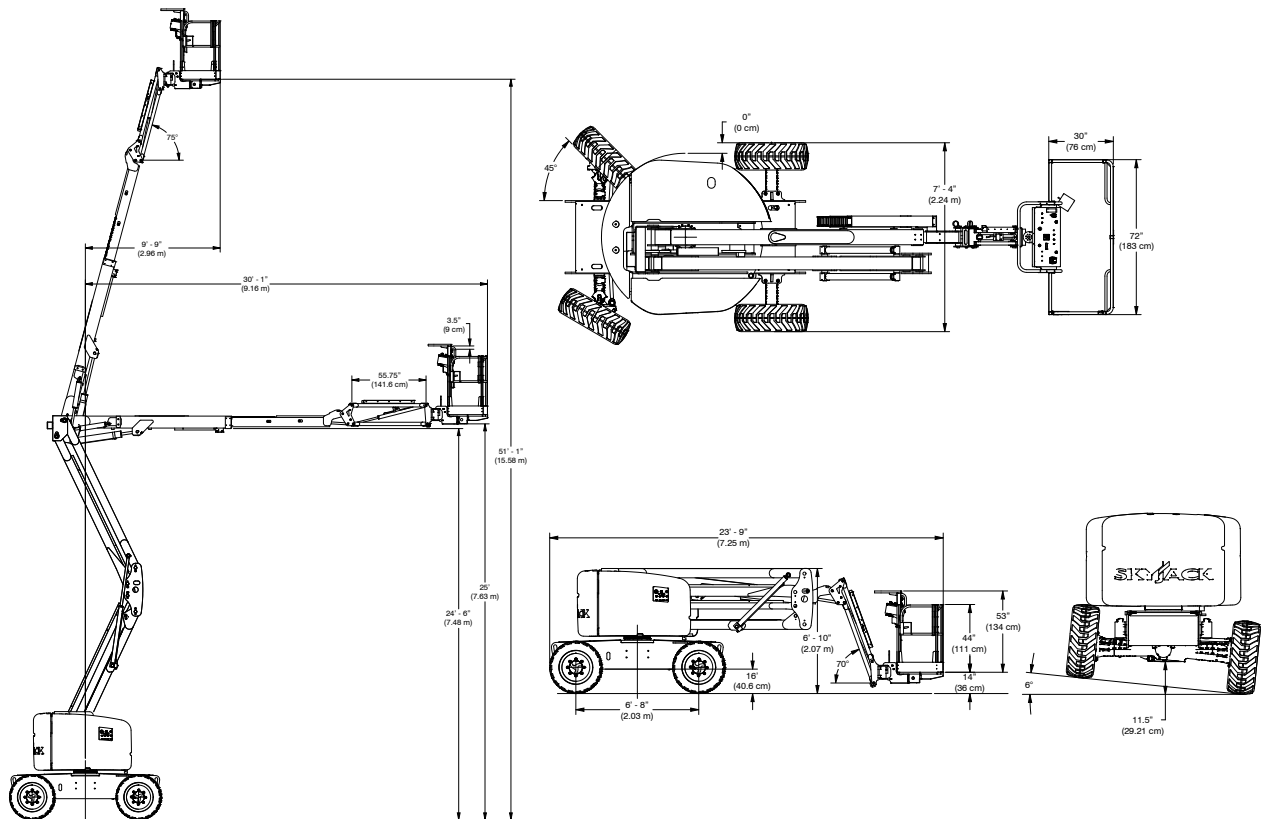
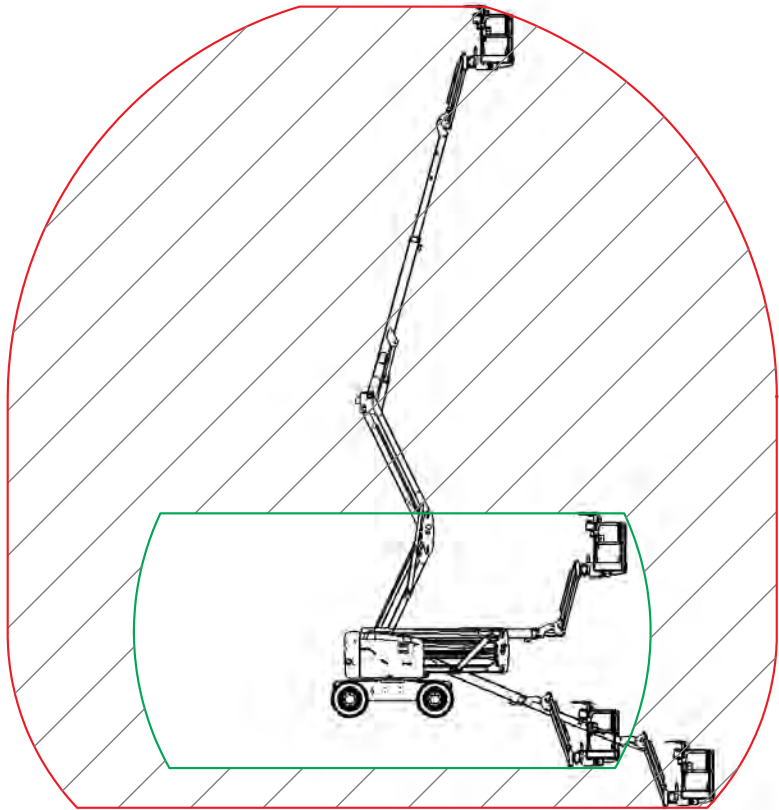

Figure 2-19. Dimension - 51AJ

Diagram 2.3 Axle Oscillation Diagram

 **WARNING**

Do not raise the platform in work mode if it is not on a firm level surface.





-  Axle oscillation free (travel mode) - drive speed 7.7 km/h (4.8 mph) max.
-  Axle oscillation locked (work mode) - drive speed 0.8 km/h (0.5 mph) max.

Figure 2-20. Axle Oscillation

Table 2.1 Standard and Optional Features

MODEL	SJ 46AJ	SJ 51AJ
STANDARD EQUIPMENT		
12-Volt DC emergency power	✓	✓
5-foot jib	✓	✓
Base controls	✓	✓
Platform controls	✓	✓
Continuous drive and steer directional sensing	✓	✓
Diesel engine	✓	✓
Engine anti-restart protection	✓	✓
Foam-filled tires	✓	✓
Four-wheel drive	✓	✓
Variable speed drive and function controls	✓	✓
Glow plug heaters	✓	✓
Load sensing system	✓	✓
Manual brake release	✓	✓
Operator horn	✓	✓
Oscillating axle (steer)	✓	✓
183 x 76 cm (72 x 30 in.) platform (side gate)	✓	✓
Rear entry spring hinged gate	✓	✓
Spring-applied hydraulically released brake	✓	✓
OPTIONAL EQUIPMENT		
3500W hydraulic generator	✓	✓
Receptacle outlet cable on platform	✓	✓
Air line to platform	✓	✓
152 x 76 cm (60 x 30 in.) platform (side gate)	✓	✓
All function motion alarm	✓	✓
Catalytic Muffler (Level 1)	✓	✓
Cold weather start kit (diesel)	✓	✓
Flashing amber light	✓	✓
Platform work light	✓	✓

60635AA-CE

Table 2.2a Specifications and Features

MODEL		SJ 46AJ	SJ51AJ	
Platform Size	Total platform length (outside)	183 cm (72 in.)	183 cm (72 in.)	
	Total platform depth (outside)	76 cm (30 in.)	76 cm (30 in.)	
Height	Working	15.4 m (50 ft. 5 in.)	16.8 m (55 ft. 1 in.)	
	Platform elevated	14.2 m (46 ft. 5 in.)	15.6 m (51 ft. 1 in.)	
	Drive	Driveable at all heights	Driveable at all heights	
	Turret	2.08 m (6 ft. 10 in.)	2.08 m (6 ft. 10 in.)	
Length	Overall with platform	6.5 m (21 ft. 4 in.)	7.25 m (23 ft. 9 in.)	
	Base and tires	2.9 m (9 ft. 6 in.)	2.9 m (9 ft. 6 in.)	
Width	Outside std. tires	2.2 m (7 ft. 4 in.)	2.2 m (7 ft. 4 in.)	
	Turret	1.8 m (6 ft.)	1.8 m (6 ft.)	
Weight	Weight (with foam-filled tires)	6,981 kg (15,390 lb.)	7,316 kg (16,130 lb.)	
Platform rotation		180 degrees	180 degrees	
Horizontal reach		7.68 m (25 ft. 2 in.)	9.16 m (30 ft. 1 in.)	
Horizontal reach @ maximum height		2.58 m (8 ft. 6 in.)	2.96 m (9 ft. 9 in.)	
Wheelbase		2.03 m (6 ft. 8 in.)	2.03 m (6 ft. 8 in.)	
Turret rotation		360 degrees	360 degrees	
Turret tailswing		-12.7 cm (-5 in.)	0	
Gradeability		45%	45%	
Ground clearance between wheels		40.6 cm (16 in.)	40.6 cm (16 in.)	
Turning Radius	Inside	Differential lock engaged	3.83 m (12 ft. 6 in.)	3.83 m (12 ft. 6 in.)
		Differential lock disengaged	2.48 m (8 ft. 2 in.)	2.48 m (8 ft. 2 in.)
	Outside	Differential lock engaged	6.45 m (21 ft. 2 in.)	6.45 m (21 ft. 2 in.)
		Differential lock disengaged	5.15 m (16 ft. 11 in.)	5.15 m (16 ft. 11 in.)
Battery	System voltage		12V DC	12V DC
	Type		Lead/Acid	Lead/Acid
	Cold cranking amperes		800A	800A
Operating Times	Main boom up		26 sec	26 sec
	Main boom down		26 sec	26 sec
	Riser boom up		26 sec	26 sec
	Riser boom down		26 sec	26 sec
	Fly boom extend		11 sec	15 sec
	Fly boom retract		19 sec	26 sec
	Jib up		39 sec	39 sec
	Jib down		23 sec	23 sec
	Turret rotate - counterclockwise 360° (fully stowed)		90 sec	90 sec
Platform rotate - full		20 sec	20 sec	
Driving Speeds	Drive speed (maximum-stowed)		7.7 kmh (4.8 mph)	7.7 kmh (4.8 mph)
	Drive speed (maximum-elevated)		0.8 kph (0.5 mph)	0.8 kph (0.5 mph)

122AA-CE

Table 2.2b Specifications and Features

MODEL			SJ 46AJ	SJ 51AJ
Engine - Deutz	Engine Type		Deutz D2011L03i	
	RPM Settings		1300 Low/1650/2000 High	
	Gross Intermittent HP		35.8 kW / 48 hp	
	Horsepower @ 2000 rpm (intermittent)		28.9 kW / 38.8 hp	
	Fuel Type		Diesel	
	Fuel Tank Capacity		64 L (17 gal.)	
	Standard Oil Factory Fill	Ambient Temperature Limits	0°F to 115°F (- 18°C to +45°C)	SAE 15W-40 API CF/CG/CH-4
	Cold Lube Oil Option		- 20°F to 90°F (- 29°C to +32°C)	SAE 5W-30 API CF/CG/CH-4
	Arctic Lube Oil Option		- 40°F to 115°F (- 40°C to +45°C)	SAE 0W-40 API CF/CG/CH-4
	Approved Alternates			See Engine Manual
Lube Oil Sump Capacity		5.5 L (1.45 gal.)		
Hydraulic Oil	Recommended Oil	Type		Shell Tellus T46
		Operating and Oil Temperature	Ambient Operation	113°F (+45°C)
			Max. Oil Temp.	200°F (+93°C)
	Approved Alternates		Chevron Rykon MV	
	<i>(Note: Cold weather starting temperatures can be improved with Skyjack options. Please consult your nearest Skyjack service center.)</i>		Mobilfluid 424	
			Esso Univis N46	
	Hydraulic Tank Capacity		91 L (24 gal.)	

123AA-CE

Table 2.3 Owner’s Annual Inspection Record

Model Number: _____		Serial Number: _____							
Recording Date									
Recording Year #	1	2	3	4	5	6	7	8	9
Owner’s Name									
Inspected By									

60564AA-CE

As described earlier in this section, this decal is located on the control compartment cowling. It must be completed after an annual inspection has been completed. Do not use the aerial platform if an inspection has not been recorded in the last 6 months.

Table 2.4 Tire/Wheel Specifications

	SJ 46AJ	SJ 51AJ
Tire Size	315/55 D20	315/55 D20
Type	Foam-filled	Foam-filled
Tire Ply Rating	12	12
Wheel Nuts Torque	393.2 Nm (290 ft-lb)	393.2 Nm (290 ft-lb)

60639AA-CE

IMPORTANT

For proper function of each axle differential, all four wheels must have same tire size installed at all times. Failure to comply with this requirement will reduce the life of the differentials and reduce overall mobility of aerial platform.

Table 2.5 Maximum Platform Capacities

	SJ 46AJ	SJ 51AJ
Total Capacity *	227 kg (500 lb.)	227 kg (500 lb.)
	2 Persons	2 Persons
Maximum Wind	12.5 m/s (28 mph)	12.5 m/s (28 mph)
Maximum Side Force	400 N (90 lbf)	400 N (90 lbf)

60640AA-CE

*



**WARNING
DRIVING ON A SLOPE**



- When driving on a slope greater than 30%, the platform capacity is limited to 136 kg (300 lb.).
- The platform must be between the non-steer wheels and must be on the downside of the hill.
- When slope increases to above 45%, the forward drive is disabled but reverse drive remains active.

Table 2.6 Floor Loading Pressure

MODEL	Gross Aerial Platform Weight		Total Aerial Platform Load					
			Wheel		LCP		OUP	
	kg	lb.	kg	lb.	kPa	psi	kPa	psf
SJ 46AJ (Standard configuration)	7,180	15,830	3,527	7,775	827	120	10.9	227
SJ 51AJ (Standard configuration)	7,543	16,630	3,842	8,470	917	133	11.4	239

60641AA-CE

- Standard Configuration = 4WD + Oscillating Axle + 315/55 D20 Foam Tires
- Gross Aerial Platform Weight = Weight + platform capacity
- LCP – Locally Concentrated Pressure – is a measure of how hard the aerial platform tire tread presses on the area in direct contact with the floor. The floor covering (tile, carpet, etc.) must be able to withstand more than the indicated values above.
- OUP – Overall Uniform Pressure – is a measure of the average load the aerial platform imparts on the whole surface projected directly underneath it. The structure of the operating surface (beams, etc.) must be able to withstand more than the indicated val

NOTE:

The LCP or OUP that an individual surface can withstand varies from structure to structure and is generally determined by the engineer or architect for that particular structure.

Locally Concentrated Pressure (LCP):

Foot Print Area = Tread Contact Area

$$LCP = \frac{\text{Maximum Wheel Load}}{\text{Foot Print Area}}$$

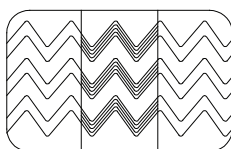
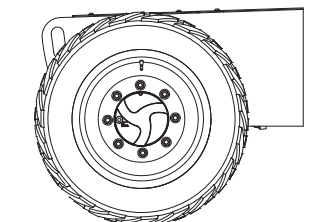

Tread Contact Area

Overall Uniform Pressure (OUP):

Base Area = Length x Width

$$OUP = \frac{\text{Aerial Platform Weight} + \text{Capacity}}{\text{Base Area}}$$

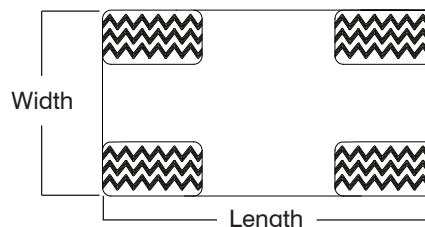
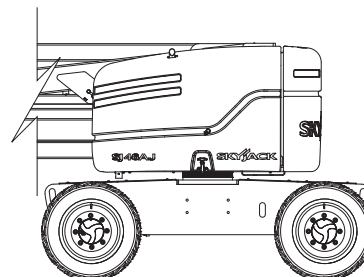

WARNING

Intermixing tires of different types or using tires of types other than those originally supplied with this equipment can adversely affect stability. Therefore, replace tires only with the exact original Skyjack-approved type. Failure to operate with matched approved tires in good condition may result in death or serious injury.

General Maintenance

Before attempting any repair work, disconnect battery by turning main power disconnect switch to “○” off position. Preventive maintenance is the easiest and least expensive type of maintenance.

Table 2.7 Maintenance and Inspection Schedule

Frequency	Daily	3 months or 150 hours	Yearly	Frequency	Daily	3 months or 150 hours	Yearly
Visual and Daily Maintenance Inspections				Jib			
Labels	A	B*†		Boom			
Electrical	A			Cylinders	A		
Limit Switches	A			Wear Pads	A		
Hydraulic	A			Hoses	A		
Engine Compartment				Power Track	A		
Main Power Disconnect Switch	A			Special Options			
Battery	A			Battery Warmer/Hydraulic Oil Heater (If Equipped)	A		
Charge Indicator	A			Work Light (If Equipped)	A		
High Pressure Filter	A			Flashing Amber Light (If Equipped)	A		
Hydraulic Pumps	A			Function Tests			
Muffler and Exhaust	A			Test Main Power Disconnect Switch	A		
Engine Pivot Tray	A			Test Charge Indicator	A		
Engine Oil Level	A			Base Control Console			
Engine Air Filter	A			Test Base Emergency Stop Light	A		
Fuel Leaks	A			Test Base Emergency Stop	A		
Control Compartment				Test Function Enable Switch & All Boom Functions	A		
Base Control Console	A			Test Platform Self-leveling	A		
Hydraulic Tank	A			Test Emergency Power	A		
Hydraulic Oil	A			Test Base/Off/Platform Switch	A		
Brake and Main Manifolds	A			Platform Control Console			
Emergency Power Unit	A			Test Platform Emergency Stop Light	A		
Fuel Tank	A			Test Platform Emergency Stop	A		
Fuel Leaks	A			Test Footswitch	A		
Base				Test Engine Enable Switch	A		
Turret Transportation Lock	A		Test Steering	A			
Drive Axle	A		Test Driving Function	A			
Oscillating Cylinder Assembly	A		Test Driving Speed	A			
Steer Cylinder Assembly	A		Test Load Sensing System	A			
Tie Rod	A		Test Emergency Power	A			
Wheel/Tire Assembly	A		Test Horn	A			
Manuels	A		Test Brakes	A			
Platform Assembly	A		Test Manual Platform Leveling	A			
Platform Control Console	A		Test Differential Lock Switch	A			
Rotary Actuator	A		Test Oscillating Axles	A			
Load Cell	A						
Jib	A						

60642AC-CE

- A - Perform Visual and Daily Maintenance Inspections & Functions Test. Refer to Section 2.8 and Section 2.9 of this manual.
- B - Perform Scheduled Maintenance Inspection. Refer to Service & Maintenance manual.
- * - Maintenance must be performed only by trained and competent personnel who are familiar with mechanical procedures.
- † - Refer to Skyjack's website @ www.skyjack.com for latest service bulletins prior to performing quarterly or yearly inspection.



WARNING

Use original or manufacturer-approved parts and components for aerial platform.

Table 2.8 Operator's Checklist



Serial Number: _____
 Model: _____
 Hourmeter Reading: _____
 Date: _____
 Time: _____

Operator's Name (Printed): _____

Operator's Signature: _____

Each item shall be inspected using the the appropriate section of the Skyjack operating manual.
 As each item is inspected, check the appropriate box.

- P - PASS
- F - FAIL
- R - REPAIRED
- NA - NOT APPLICABLE

INSPECTION FREQUENCY

- DAILY
- FREQUENTLY
- ANNUALLY
- BI-ANNUALLY

Visual and Daily Maintenance Inspections				
Labels				
Electrical				
Limit Switches				
Hydraulic				
Engine Compartment				
Main Power Disconnect Switch				
Battery				
Charge Indicator				
High Pressure Filter				
Hydraulic Pumps				
Muffler and Exhaust				
Engine Pivot Tray				
Engine Oil Level				
Engine Air Filter				
Fuel Leaks				
Control Compartment				
Base Control Console				
Hydraulic Tank				
Hydraulic Oil				
Brake and Main Manifolds				
Emergency Power Unit				
Fuel Tank				
Fuel Leaks				
Base				
Turret Transportation Lock				
Drive Axle				
Oscillating Cylinder Assembly				
Steer Cylinder Assembly				
Tie Rod				
Wheel/Tire Assembly				
Manuals				
Platform Assembly				
Platform Control Console				
Rotary Actuator				
Load Cell				
Jib				

Boom				
Cylinders				
Wear Pads				
Hoses				
Power Track				
Special Options				
Battery Warmer/Hydraulic Oil Heater (If Equipped)				
Work Light (If Equipped)				
Flashing Amber Light (If Equipped)				
Function Tests				
Test Main Power Disconnect Switch				
Test Charge Indicator				
Base Control Console				
Test Base Emergency Stop Light				
Test Base Emergency Stop				
Test Function Enable Switch & All Boom Functions				
Test Platform Self-leveling				
Test Emergency Power				
Test Base/Off/Platform Switch				
Platform Control Console				
Test Platform Emergency Stop Light				
Test Platform Emergency Stop				
Test Footswitch				
Test Engine Enable Switch				
Test Steering				
Test Driving Function				
Test Driving Speed				
Test Load Sensing System				
Test Emergency Power				
Test Horn				
Test Brakes				
Test Manual Platform Leveling				
Test Differential Lock Switch				
Test Oscillating Axles				

60643AB-CE

Note:
 Make a copy of this page or visit the Skyjack web site:
www.skyjack.com for a printable copy.

Table 2.8 EC Declaration of Conformity

EC Declaration of Conformity

We, SKYJACK INC., [*], declare under our sole responsibility that the product Boom Type Mobile Elevating Work Platform

Model number: [*]

Serial number: [*]

To which this declaration relates is in conformity with the following directives:

Machine Directive 98/37/EC
Notified body is: [*]

EC Type Examination Certificate No: [*]

Directive 2000/14/EC: [*]

Directive 2004/108/EC - (EN133309:2000)
Certified laboratory: [*]

The Technical Construction File is maintained at:
[*]

The authorized representative located within the community is:
[*]

Place of issue:
[*]





Note: In case of unauthorized modification, this Declaration becomes invalid.

Test Engineer:

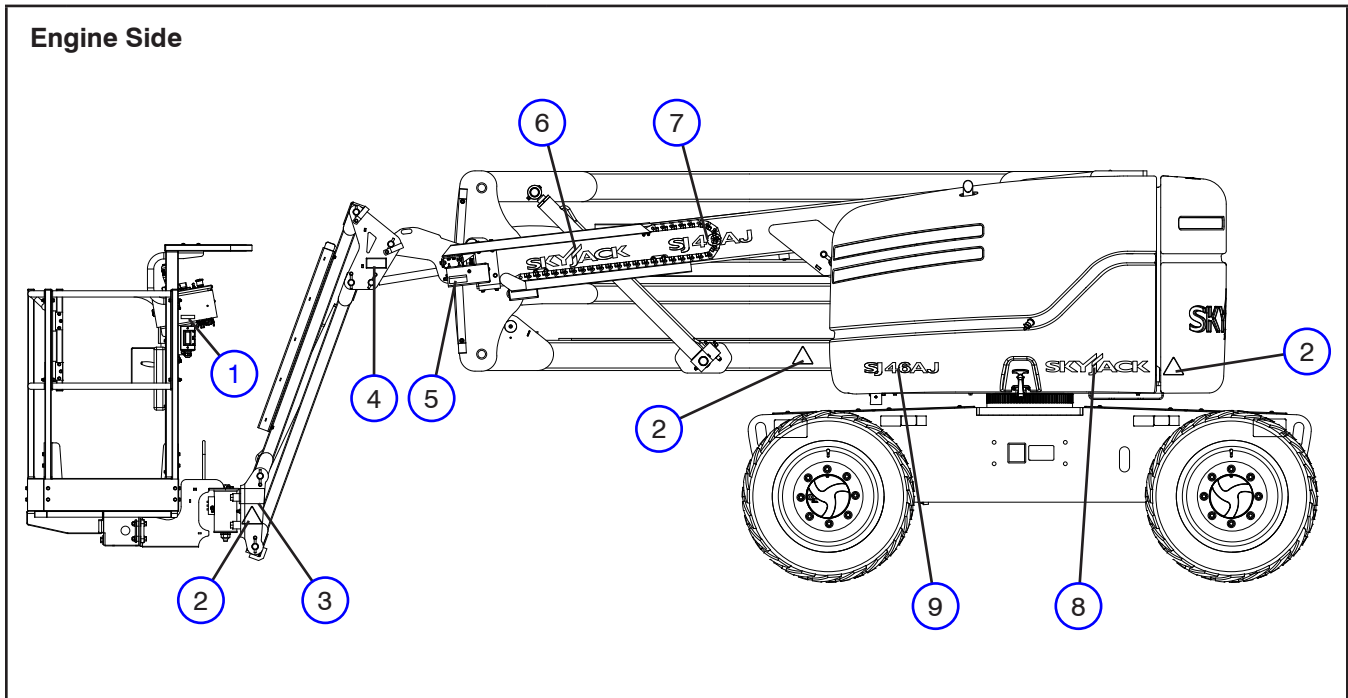

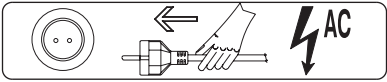

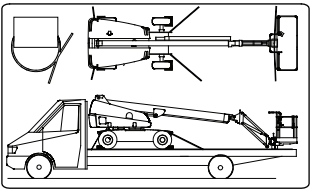
Quality Coordinator:

[*] For information refer to the English Declaration of Conformity provided with your aerial platform.

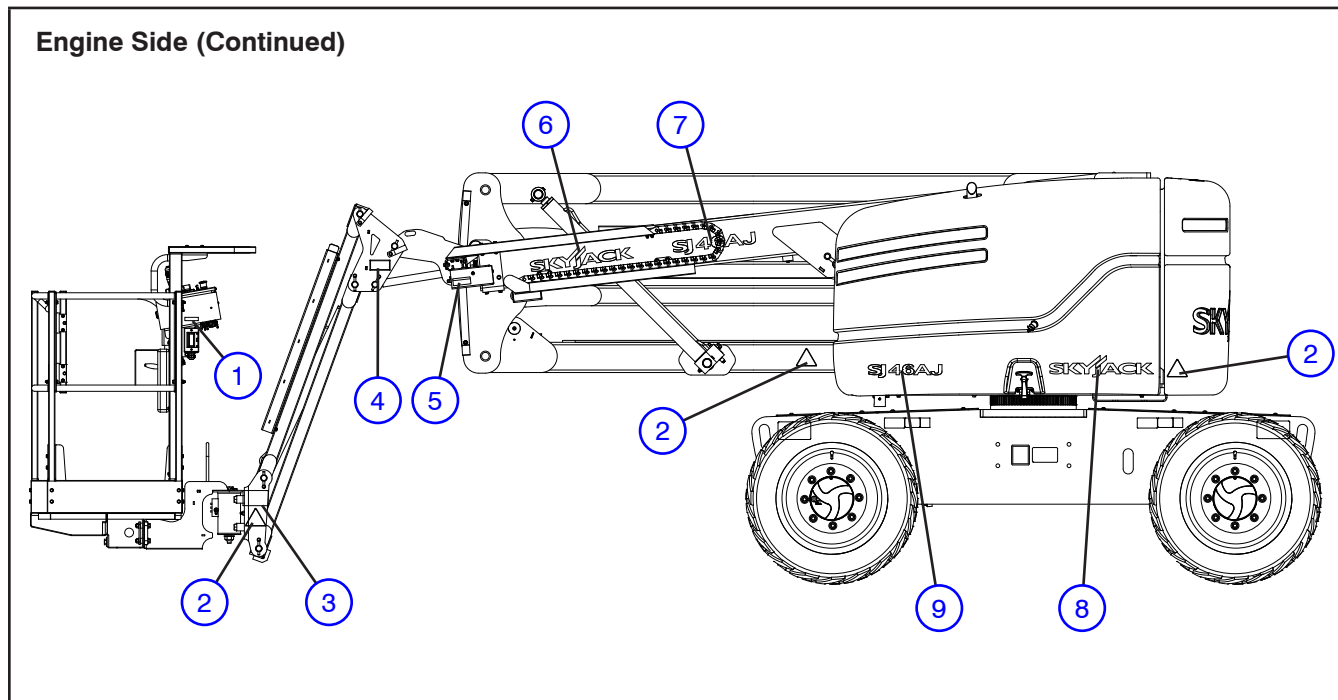

No.	Label Pictorial	Description
1		<p>Connect AC Supply Connect AC supply here.</p>
2		<p>Body Crushing Hazard Danger - Body crushing hazard</p>
3		<p>Tie Down Points Only use these points for tying down.</p>
4		<p>Crushing Hazard Danger - Crushing hazard</p>
5		<p>Warning - Do Not Alter Aerial platform altering warning</p>





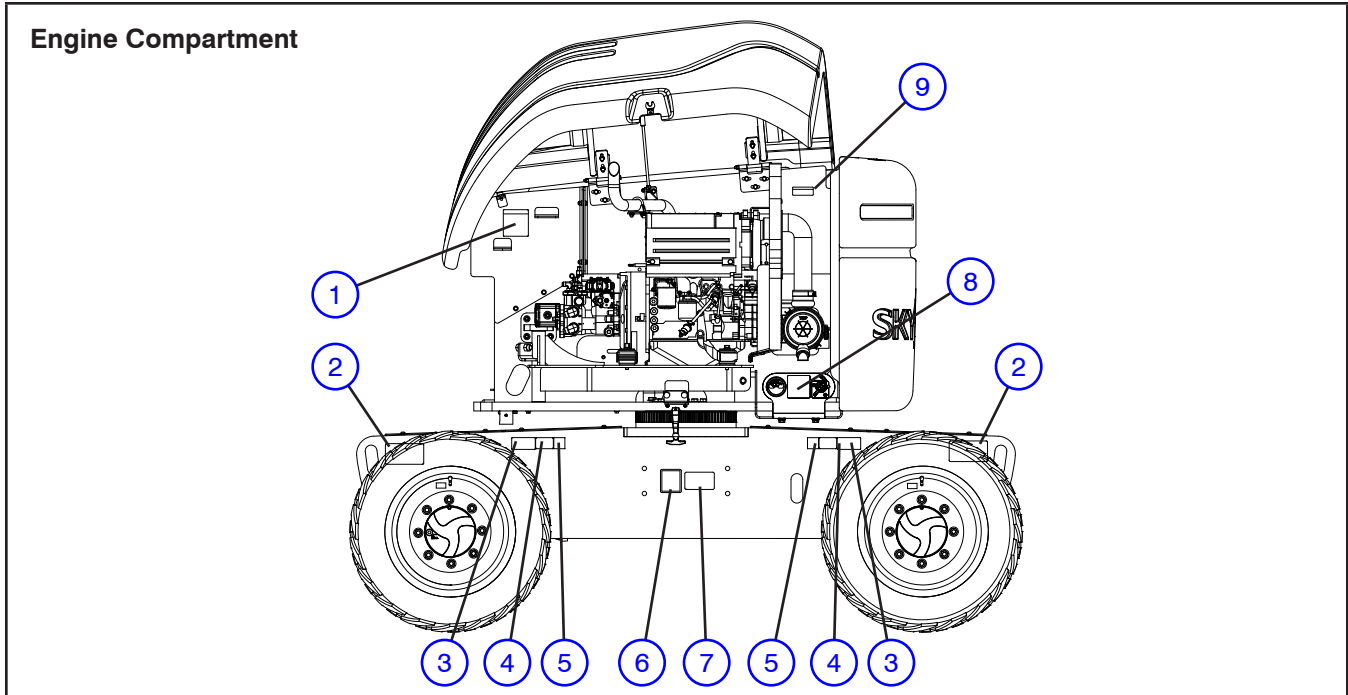

No.	Label Pictorial	Description
6		Skyjack Logo Skyjack logo - grey
7		Model Number* Product Identifier - grey *Model number will vary, may not be as shown.
8		Skyjack Logo Small Skyjack logo - blue and red
9		Model Number* Product Identifier - blue *Model number will vary, may not be as shown.

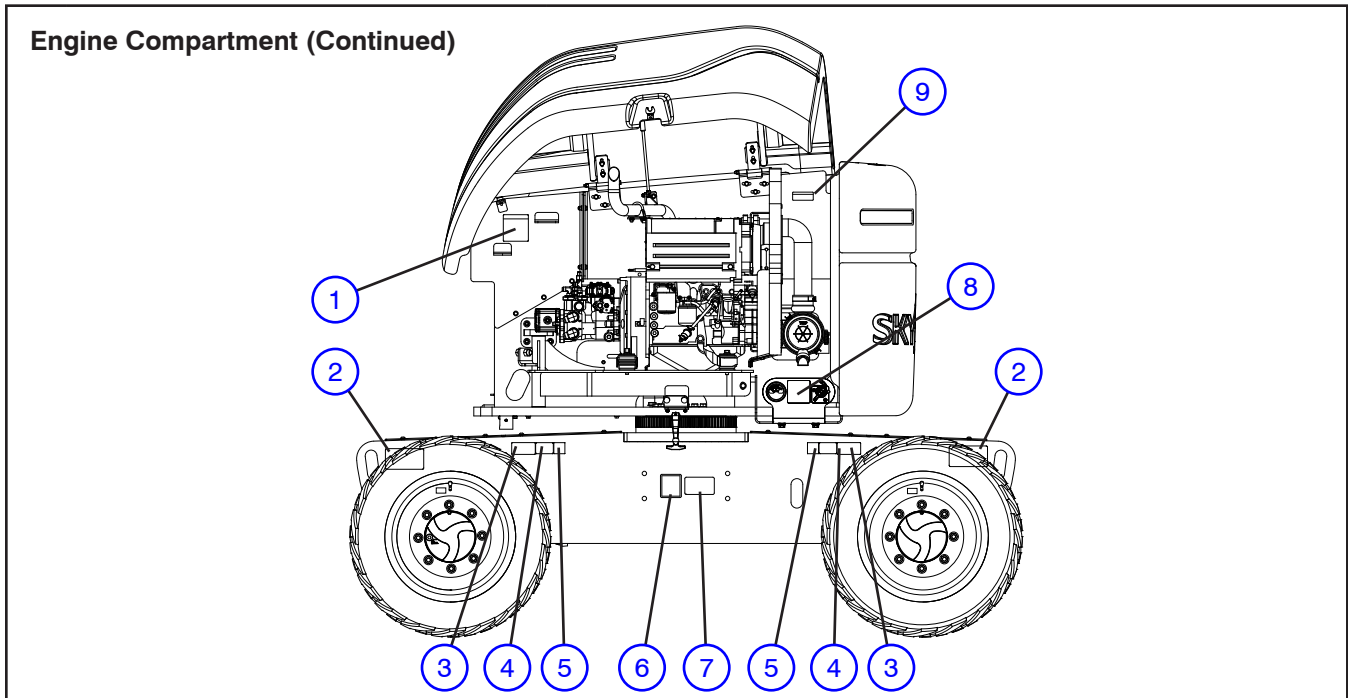

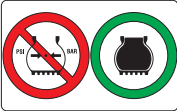

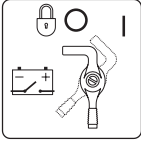
No.	Label Pictorial	Description
1	<p>CAUTION Winching and Towing Instructions 1. Always use proper winching and towing procedures. Do not exceed the rated capacity of the winch or the rated load capacity of the platform. 2. Do not attempt to tow or winch anything that is not designed for towing or winching. 3. Do not use the winch to lift or lower the platform. 4. Do not use the winch to pull on any cables, wires, or hoses. 5. Do not use the winch to pull on any other parts of the platform. 6. Do not use the winch to pull on any other parts of the vehicle. 7. Do not use the winch to pull on any other parts of the equipment. 8. Do not use the winch to pull on any other parts of the machinery. 9. Do not use the winch to pull on any other parts of the structure. 10. Do not use the winch to pull on any other parts of the system. 11. Do not use the winch to pull on any other parts of the unit. 12. Do not use the winch to pull on any other parts of the device. 13. Do not use the winch to pull on any other parts of the apparatus. 14. Do not use the winch to pull on any other parts of the machine. 15. Do not use the winch to pull on any other parts of the equipment.</p>	<p>Towing and Winching Procedure Instructions for winching and towing</p>
2		<p>Lift and Tie Down Points Only use these points for lifting or tying down.</p>
3		<p>Wheel Specifications Refer to manual for wheel type, offset, pressure and torque.</p>
4		<p>Wheel Load* Indicates rated wheel load. *Wheel load will vary over different aerial platforms.</p>



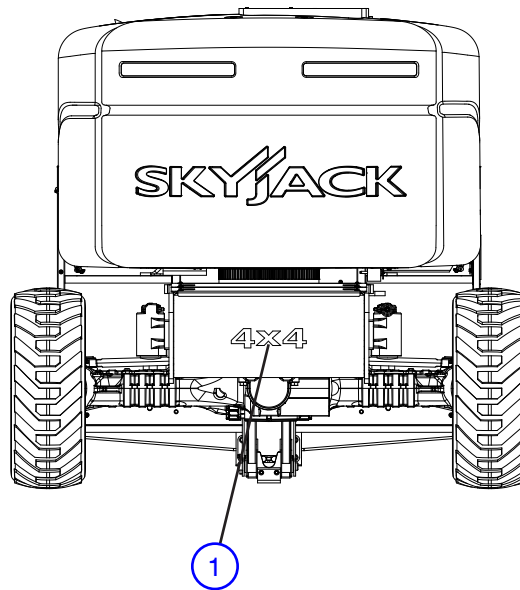

No.	Label Pictorial	Description
5		<p>Foam-filled Tire Indicates foam-filled tire.</p>
6		<p>Sound Power Level Guaranteed maximum sound power level</p>
7		<p>“CE” CE rating mark</p>
8		<p>Main Power Disconnect Main power disconnect lever</p>
9		<p>Warning - Do Not Alter Aerial platform altering warning</p>





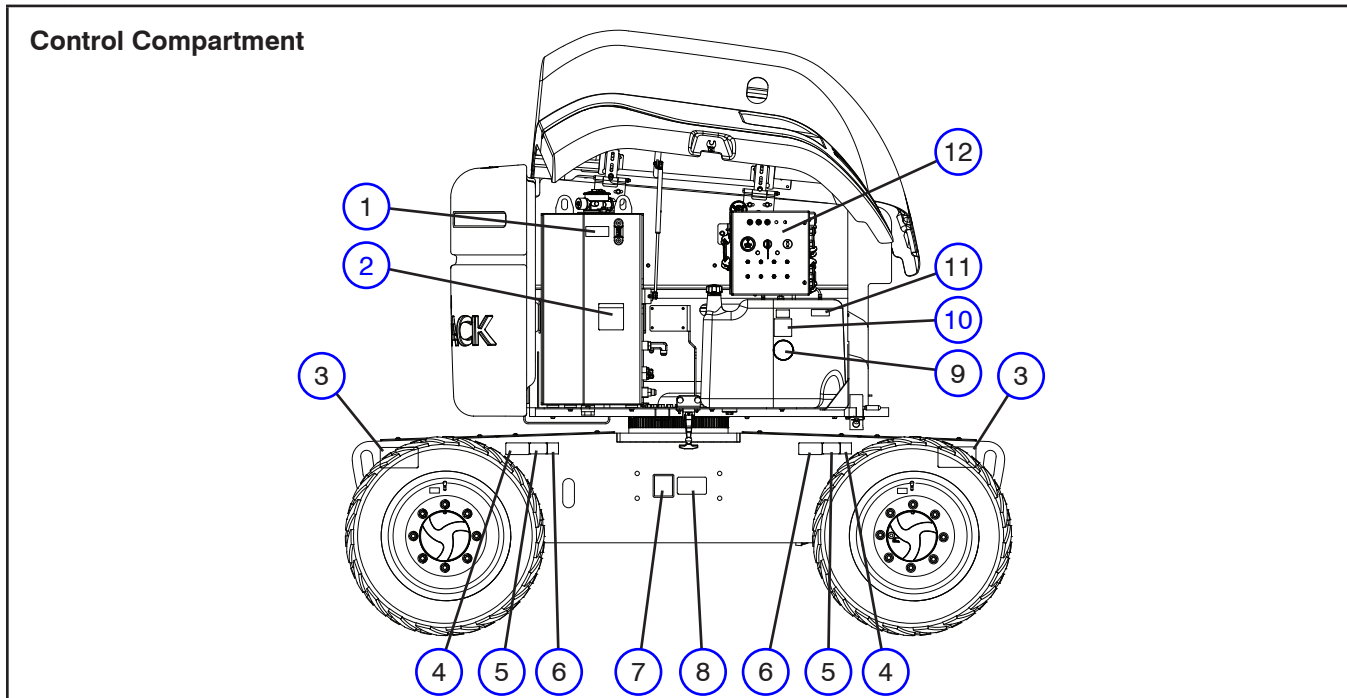

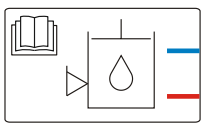
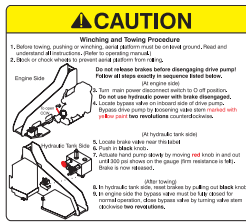
Rear Side - Base

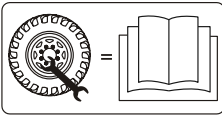
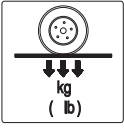

No.	Label Pictorial	Description
1		<p>4x4 (If equipped)</p> <p>Product identifier - 4 wheel drive</p>



No.	Label Pictorial	Description
1		<p>Hydraulic Oil Level Indicates minimum/maximum oil level.</p>
2		<p>Towing and Winching Procedure Instructions for winching and towing</p>
3		<p>Lift and Tie Down Points Only use these points for lifting or tying down.</p>
4		<p>Wheel Specifications Refer to manual for wheel type, offset, pressure and torque.</p>
5		<p>Wheel Load* Indicates rated wheel load. *Wheel load will vary over different aerial platforms.</p>

Control Compartment (Continued)		
No.	Label Pictorial	Description
6		Foam-filled Tire Indicates foam-filled tire.
7		Sound Power Level Guaranteed maximum sound power level
8		“CE” CE rating mark
9		No Smoking Do not smoke near this location.
10		Diesel Use diesel fuel only.
11		Grease Points Maintenance Refer to service and maintenance manual “  ” for lubricating aerial platform.

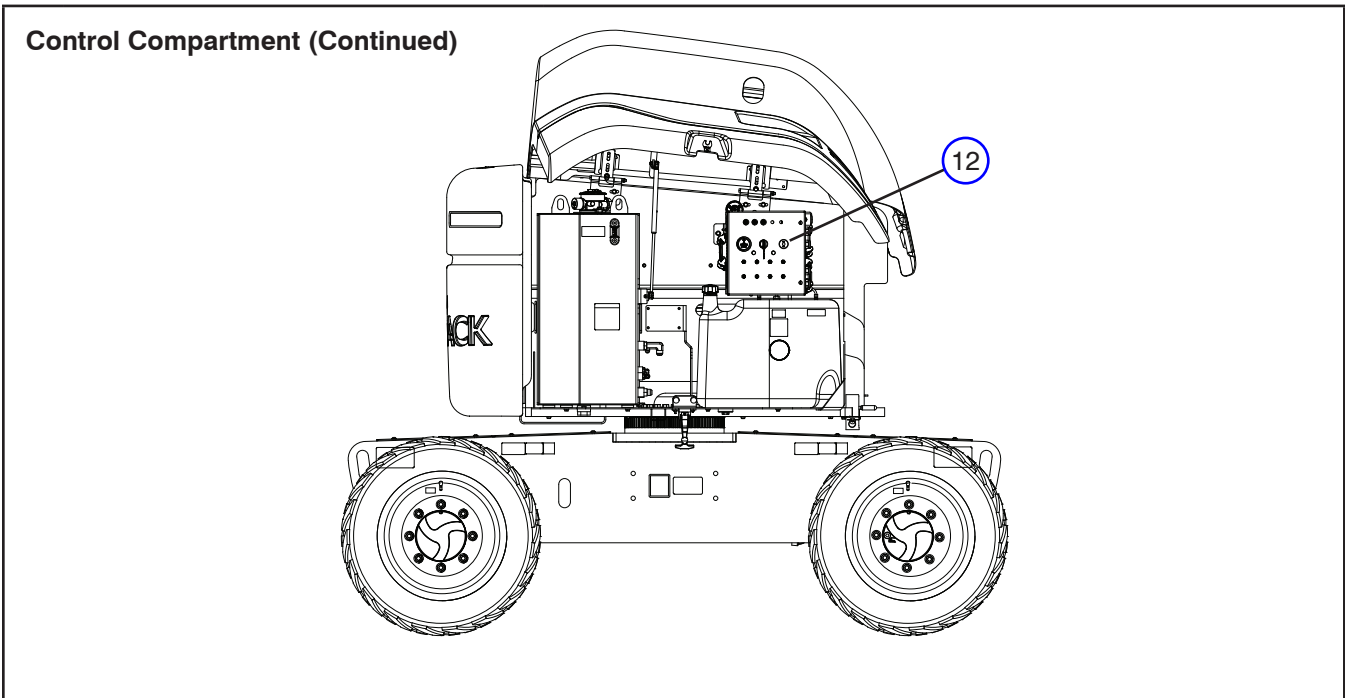

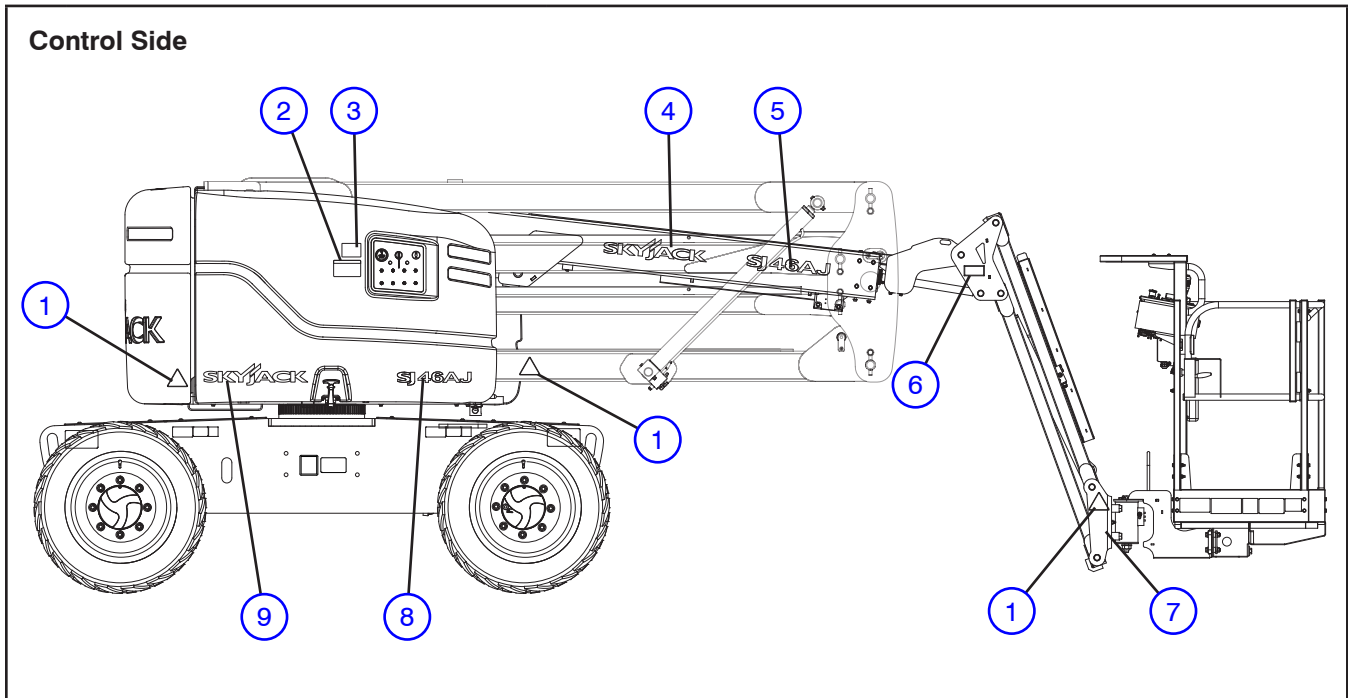

No.	Label Pictorial	Description
12		<p>Base Control Console</p> <p>Push “” breaker back in to reset. Select and hold “” to enable error blink code for engine control unit (ECU).</p> <p>Read “” operating manual.</p> <p>Select “” to enable base control console, “” to turn engine off or “” to enable platform control console.</p> <p>Push “” emergency stop to stop engine and disable controls.</p> <p>Select “” to extend fly boom or “” to retract fly boom.</p> <p>Select “” to rotate platform to the left or “” to rotate to the right.</p> <p>Select “” to tilt platform up or “” to tilt platform down.</p> <p>Select “” to move jib up or “” to move jib down.</p> <p>Select “” to rotate turret to the left or “” to rotate to the right.</p> <p>Select “” to raise riser or “” to lower riser.</p> <p>Select “” to raise main boom or “” to lower main boom.</p> <p>Push and hold “” to start engine or “” to enable the emergency power unit.</p> <p>Push and hold “” in either direction to enable base control functions.</p>

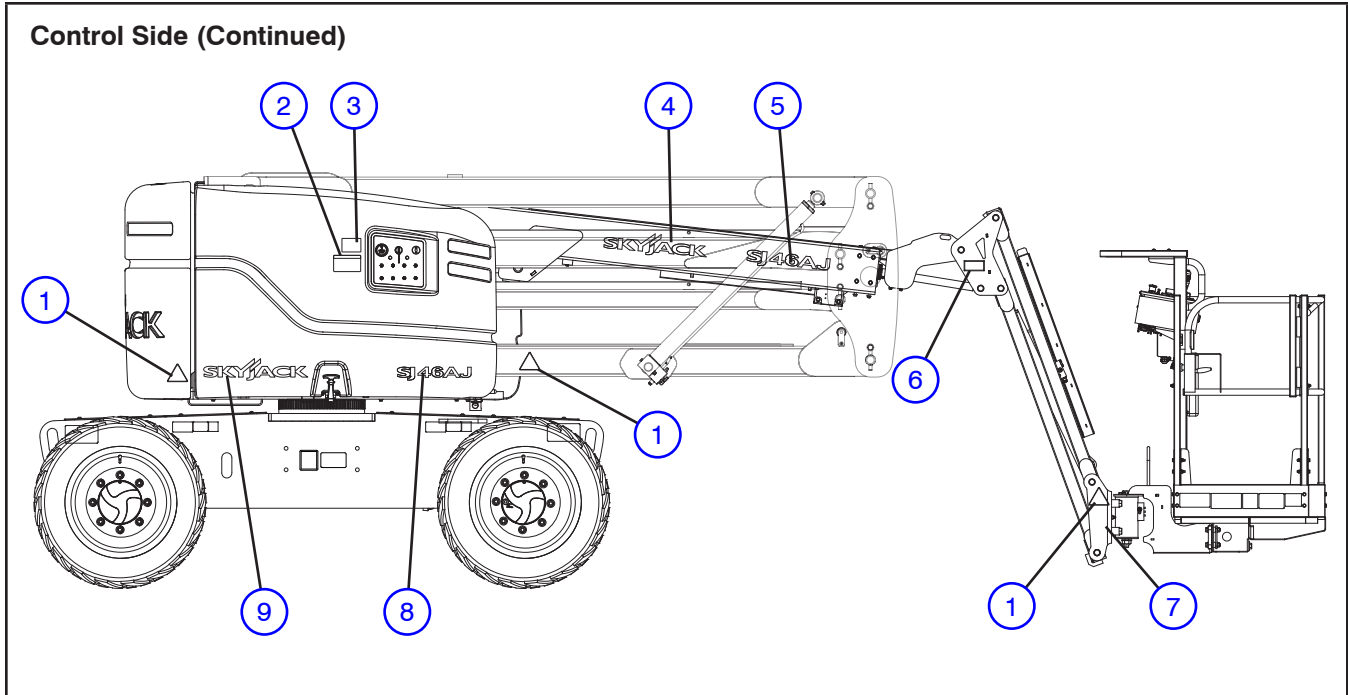

No.	Label Pictorial	Description
1		Body Crushing Hazard Danger - Body crushing hazard
2		Annual Inspection Ensure that work platform has received annual inspection prior to operation.
3		Emergency Lowering Procedure In case of emergency, follow procedure outlined in label to lower the platform.
4		Skyjack Logo Big Skyjack logo - grey
5		Model Number* Product Identifier - grey *Model number will vary, may not be as shown.

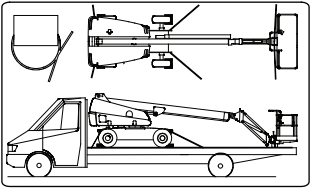

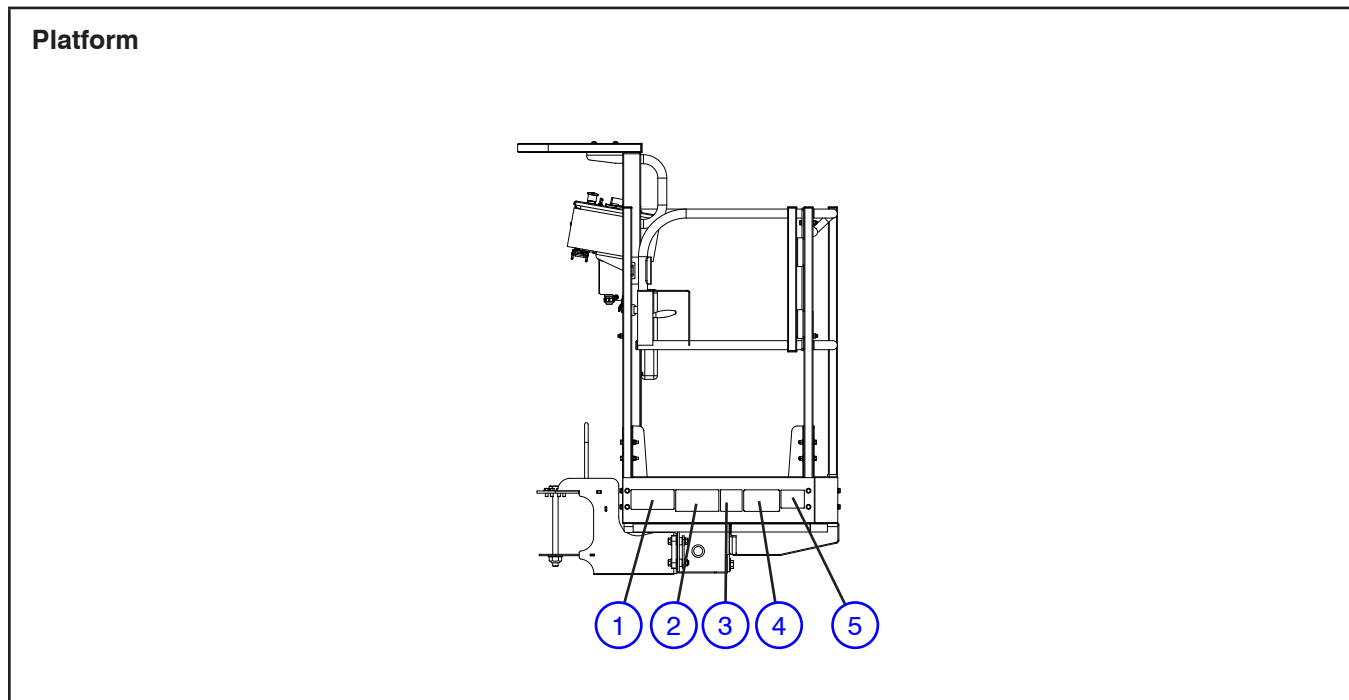

No.	Label Pictorial	Description
6		<p>Crushing Hazard</p> <p>Danger - Crushing hazard</p>
7		<p>Tie Down Points</p> <p>Only use these points for tying down.</p>
8		<p>Model Number*</p> <p>Product Identifier - blue *Model number will vary, may not be as shown.</p>
9		<p>Skyjack Logo</p> <p>Small Skyjack logo - blue and red</p>



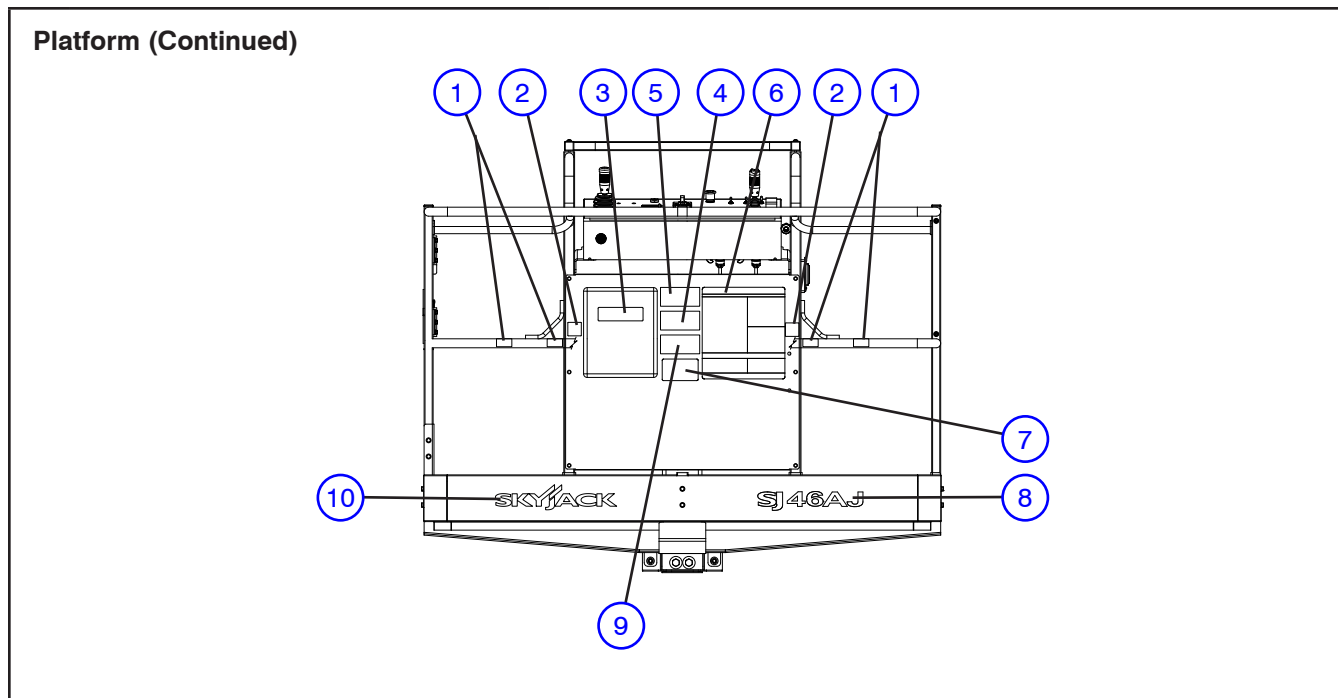

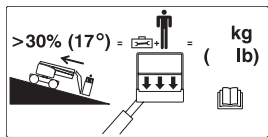
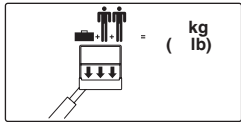

No.	Label Pictorial	Description
1		<p>Platform Capacity - Driving on a Slope*</p> <p>Rated work load when driving on a slope between 30% and 45%. Rated work load includes the weight of both personnel and material, and maximum number of people in each configuration. Do not exceed total weight or maximum number of people. Load platform uniformly. *Platform capacity will vary over different aerial platforms.</p>
2		<p>Platform Capacity - Operating on Level Ground*</p> <p>Rated work load when operating on a level ground. Rated work load includes the weight of both personnel and material, and maximum number of people in each configuration. Do not exceed total weight or maximum number of people. Load platform uniformly. *Platform capacity will vary over different aerial platforms.</p>
3		<p>Operator checklist</p> <p>Operator checklist. Perform check prior to use.</p>
4		<p>Horizontal Load Rating</p> <p>Apply no more than indicated side load. Operate below indicated wind speed only.</p>
5		<p>No Jewelry</p> <p>Caution - Do not wear jewelry.</p>

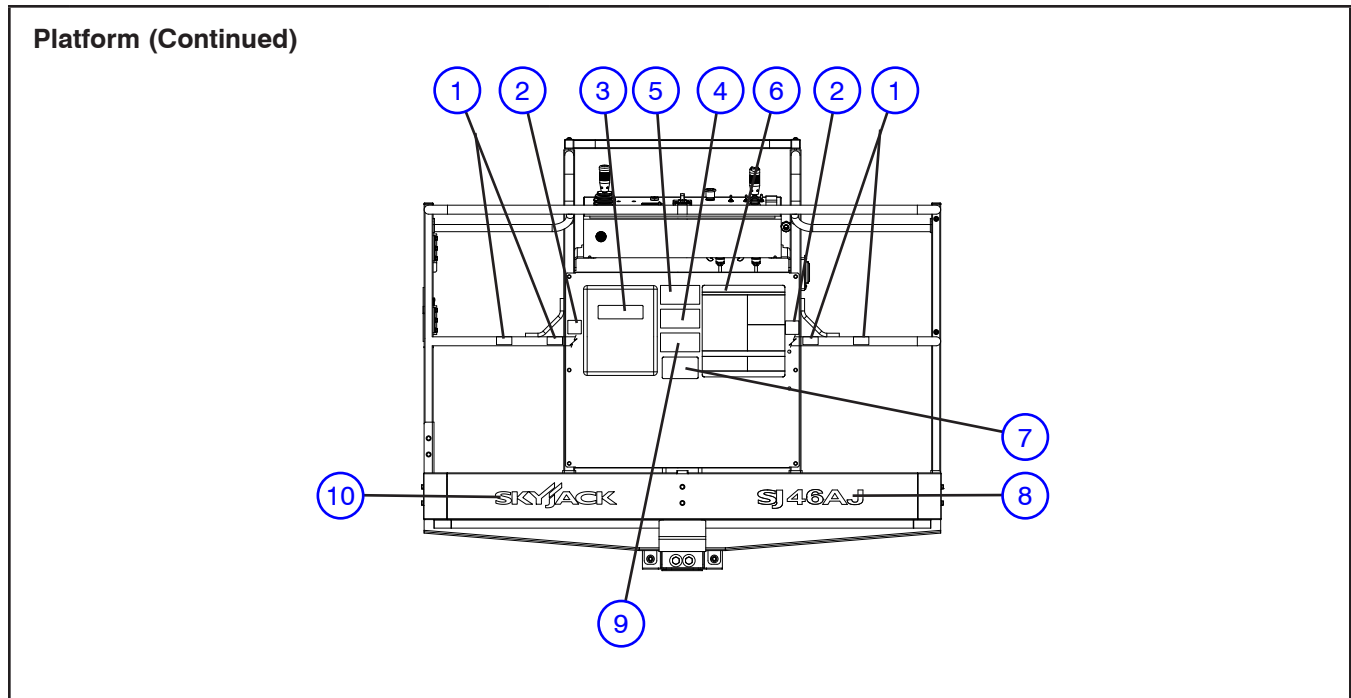

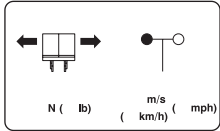

No.	Label Pictorial	Description
1		<p>Warning - No Step</p> <p>No step warning</p>
2		<p>Harness Anchorage</p> <p>Anchor safety belt/harness tethers here.</p>
3		<p>Manual Box</p> <p>Indicates location of operating manual.</p>
4		<p>Platform Capacity - Driving on a Slope*</p> <p>Rated work load when driving on a slope between 30% and 45%. Rated work load includes the weight of both personnel and material, and maximum number of people in each configuration. Do not exceed total weight or maximum number of people. Load platform uniformly.</p> <p>*Platform capacity will vary over different aerial platforms.</p>
5		<p>Platform Capacity - Operating on Level Ground*</p> <p>Rated work load when operating on a level ground. Rated work load includes the weight of both personnel and material, and maximum number of people in each configuration. Do not exceed total weight or maximum number of people. Load platform uniformly.</p> <p>*Platform capacity will vary over different aerial platforms.</p>

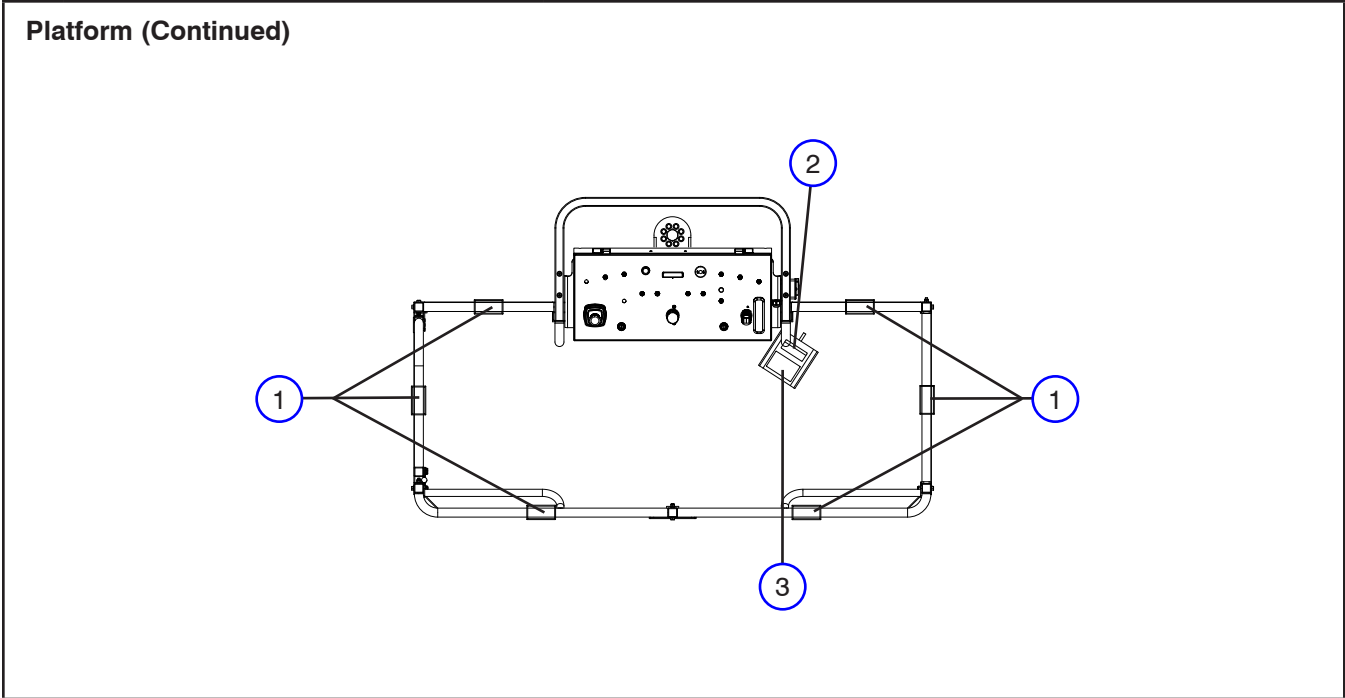

No.	Label Pictorial	Description
6		<p>Hazard Identification</p> <p>Read and understand outlined risks associated with this work platform prior to operation.</p>
7		<p>AWPT “Click It!”</p> <p>Indicates full body harness awareness.</p>
8		<p>Model Number*</p> <p>Product Identifier - blue *Model number will vary, may not be as shown.</p>
9		<p>Horizontal Load Rating</p> <p>Apply no more than indicated side load. Operate below indicated wind speed only.</p>
10		<p>Skyjack Logo</p> <p>Small Skyjack logo - blue</p>

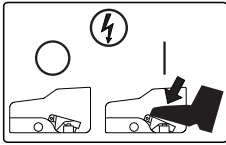

No.	Label Pictorial	Description
1		<p>Crushing Hazard</p> <p>Danger - Crushing hazard</p>
2		<p>Warning - Do Not Alter</p> <p>Aerial platform altering warning</p>
3		<p>Footswitch Enable (On/Off)</p> <p>Depress and hold footswitch to enable platform function.</p>

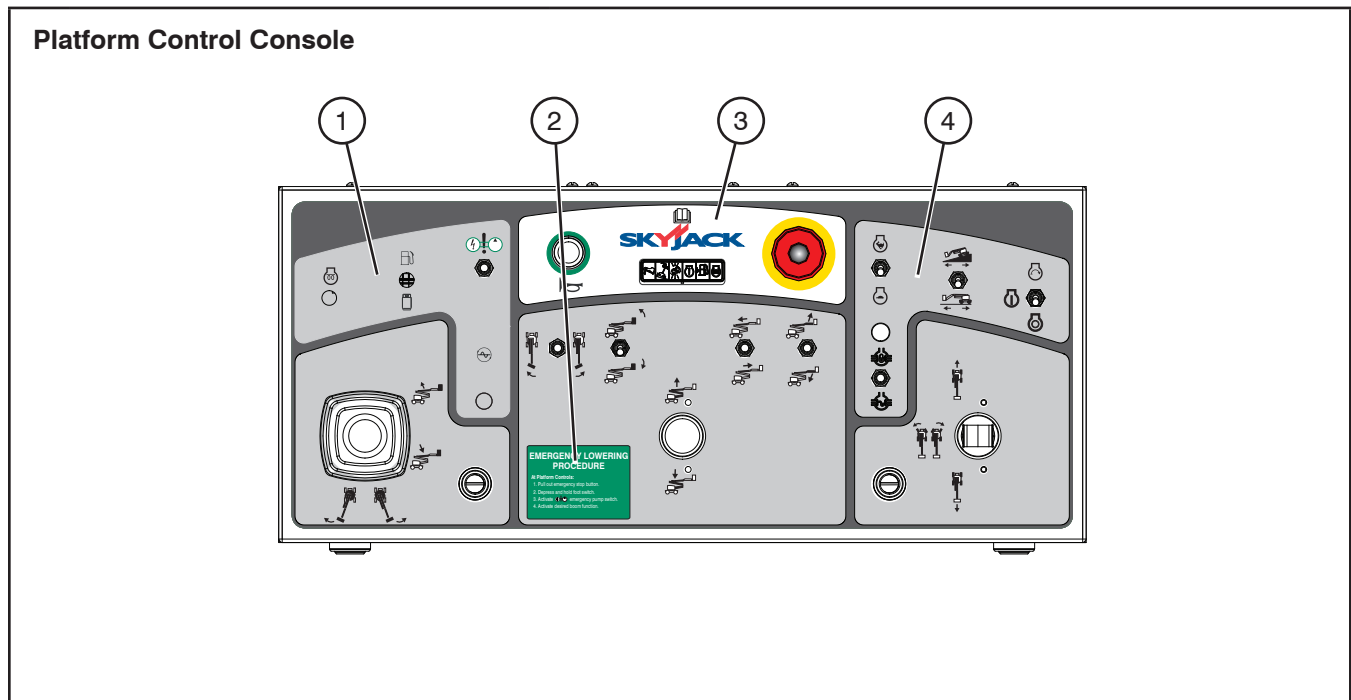



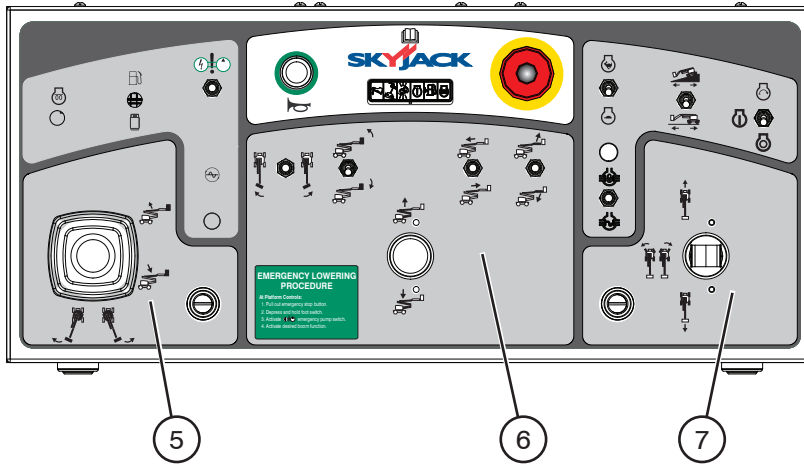

No.	Label Pictorial	Description
1		<p>Glow Plugs/Emergency Power Unit</p> <p>Select “” to energize glow plugs. Select “” for diesel fuel or “” for propane fuel. Push and hold “” to enable emergency power unit. Select “” to turn hydraulic generator on or “” to turn it off.</p>
2		<p>Emergency Lowering Procedure</p> <p>Follow procedure outlined in label to lower the platform.</p>
3		<p>E-Stop/Horn</p> <p>Select “” to sound horn. Read operating manual “”. Push “” emergency stop to stop engine and disable controls.</p>
4		<p>Engine Controls</p> <p>Select either “” high or “” low engine throttle speed. Select “” to engage differential lock or “” to disengage differential lock. Select “” low torque when driving on level ground or “” high torque when driving on a slope. Push and hold “” to start engine and then return “” on position or select “” to turn engine off.</p>

Platform Control Console (Continued)

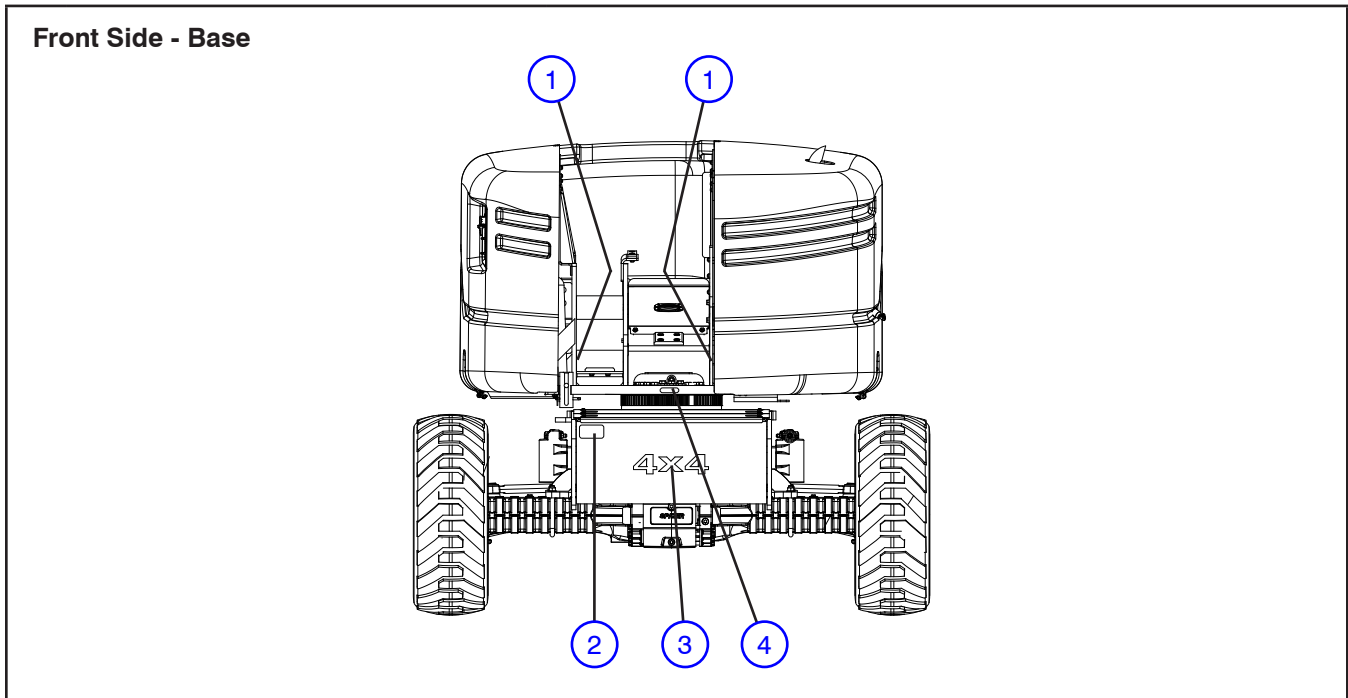

No.	Label Pictorial	Description
5		<p>Boom/Turret Controller</p> <p>Push and hold controller in this direction “” to rotate turret to the left or “” to rotate turret to the right.</p> <p>Push and hold the controller in this direction “” to raise main boom or “” to lower main boom.</p>
6		<p>Boom/Jib/Platform Controls</p> <p>Select “” to rotate platform to the left or “” to the right.</p> <p>Select “” to tilt platform up or “” down</p> <p>Select “” to extend fly boom or “” to retract fly boom.</p> <p>Select “” to move jib up or “” to move jib down.</p> <p>Select “” to raise riser or “” to lower riser.</p>
7		<p>Drive/Steer Controller</p> <p>Press rocker switch in this direction “” to steer left or “” to steer right.</p> <p>Push and hold controller in this direction “” to drive forward or “” to drive backward.</p>

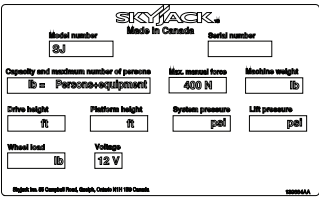

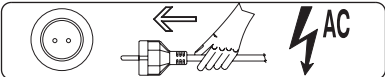
No.	Label Pictorial	Description
1		<p>Body Crushing Hazard</p> <p>Danger - Body crushing hazard</p>
2		<p>Serial Plate*</p> <p>Product identification and specifications *Serial plates will vary, may not be as shown.</p>
3		<p>4x4 (If equipped)</p> <p>Product identifier - 4 wheel drive</p>
4		<p>Connect AC Supply</p> <p>Connect AC supply here.</p>



Reliable lift solutions by people who care.

www.skyjack.com