



OPERATING MANUAL (ANSI/CSA)

DC ELECTRIC SCISSORS

MODELS SJIII 3215 SJIII 3219 SJIII 3220 SJIII 3226 SJIII 4620 SJIII 4626 SJIII 4632

170469AHA November 3 2022

SKYJACK[™]

This manual is based on serial number(s):

SJIII 3215	10 001 094 & Above
SJIII 3219	22 067 625 & Above
SJIII 3220	60 004 661 & Above
SJIII 3226	27 020 827 & Above
SJIII 46XX	70 020 612 & Above

Please refer to the website (www.skyjack.com) for older Serial Numbers.

Skyjack Service Center

3451 Swenson Ave. St. Charles,
Illinois, 60174 USA
Phone: 630-262-0005
Toll Free: 1-800-275-9522
Fax: 630-262-0006
Email: service@skyjack.com

Parts (North America)

Toll Free: 1-800-965-4626
Toll Free Fax: 1-888-782-4825
E-mail: parts@skyjack.com

Skyjack Australia Pty Ltd.

Unit 1, 35 Honeycomb Drive
Eastern Creek
New South Wales 2766
Australia
Tel: +61 (0) 2 9854 0700
Fax: +61 (0) 2 9854 0777

Parts & Service (Europe)

Unit 1 Maes Y Clawdd
Maesbury Road Industrial Estate
Oswestry, Shropshire SY10 8NN UK
Phone: +44-1691-676-235
Fax: +44-1691-676-238
E-mail: info@skyjackeurope.co.uk

Skyjack Brasil

Alameda Júpiter, 710
Loteamento American Park Empresarial
Indaiatuba, SP, Brasil 13347-653
Tel: +55 19 3936 0132

The Safety Alert Symbol identifies important safety messages on aerial platform, safety signs in manuals or elsewhere. When you see this symbol, be alert to the possibility of personal injury or death. Follow the instructions in the safety message.



This Safety Alert Symbol means attention!

Become alert! Your safety is involved.



DANGER

DANGER indicates an imminently hazardous situation which, if not avoided, will result in death or serious injury.



WARNING

WARNING indicates a potentially hazardous situation which, if not avoided, could result in death or serious injury.



CAUTION

CAUTION indicates a potentially hazardous situation which, if not avoided, may result in minor or moderate injury. It may also be used to alert against unsafe practices.

IMPORTANT

IMPORTANT indicates a procedure essential for safe operation and which, if not followed, may result in a malfunction or damage to the aerial platform.

Table of Contents

Section 1 - About Your Aerial Platform	5
Read and Heed	5
Safety Rules.....	6
Section 2 - Familiarization.....	13
2.1 Familiarization of SJIII Series.....	13
2.2 Component Identification	14
2.3 Visual & Daily Maintenance Inspections	18
2.4 Function Tests.....	25
2.5 Winching and Towing Procedures	32
2.6 Emergency Lowering Procedure.....	34
Section 3 - Operation.....	35
3.1 General	35
3.2 Major Components	36
3.3 Major Assemblies	37
3.4 Serial Number Nameplate	37
3.5 Component Identification	38
3.6 Component Identification (Optional Equipment/Attachments).....	41
3.7 Operator's Responsibility	44
3.8 Start Operation	45
3.9 Guardrail Folding Procedure.....	50
3.10 Loading/Unloading	52
3.11 Moving the Aerial Platform Through a Doorway	54
3.12 Maintenance Support Procedure	56
3.13a Battery Maintenance.....	57
3.13b Battery Maintenance (If Equipped).....	60
Section 4 - Tables.....	63
Table 4.1 Standard and Optional Features - ANSI/CSA	63
Table 4.2 Owner's Annual Inspection Record.....	64
Table 4.3a Specifications and Features	65
Table 4.3b Specifications and Features	66
Table 4.4 Floor Loading Pressure	67
Table 4.5 Maximum Platform Capacities (Evenly Distributed).....	69
Table 4.6 Maintenance and Inspection Schedule.....	70
Table 4.7 Operator's Checklist.....	71
Section 5- Labels.....	73
Section 6 - Skyjack Features	106

SKYJACK is continuously improving and expanding product features on its equipment, therefore, specifications and dimensions are subject to change without notice.

Aerial Platform and Mobile Elevating Work Platform Definition

A mobile device that has a positionable platform supported from ground level by a structure.

Purpose of Equipment

The SKYJACK SJIII DC Electric series aerial platforms are designed to transport and raise personnel, tools and materials to overhead work areas.

Use of Equipment

The aerial platform is a highly maneuverable, mobile work station. Work platform elevation and elevated driving must only be done on a firm, level surface.

Manual

The operating manual is considered a fundamental part of the aerial platform. It is a very important way to communicate necessary safety information to users and operators. A complete and legible copy of this manual must be kept in the provided weather-resistant storage compartment on the aerial platform at all times.

Operator

The operator must read and completely understand both this operating manual and the safety panel label located on the platform and all other warnings in this manual and on the aerial platform. Compare the labels on the aerial platform with the labels found within this manual. If any labels are damaged or missing, replace them immediately.

Service Policy and Warranty

SKYJACK warrants each new SJIII Series work platform to be free of defective parts and workmanship for the first 24 months. Any defective part will be replaced or repaired by your local SKYJACK dealer at no charge for parts or labor. Contact the SKYJACK Service Department for warranty statement extensions or exclusions.

Optional Accessories

The SKYJACK aerial platform is designed to accept a variety of optional accessories. These are listed under “Standard and Optional Features” in [Table 4.1](#). Operating instructions for these options (if equipped) are located in [Section 3](#) of this manual.

For non-standard components or systems, contact the SKYJACK Service Department at



: 800 275-9522



: 630 262-0006

Include the model and serial number for each applicable aerial platform.

Scope of this Manual

- a. This manual applies to the ANSI/SIA, CSA version of the SJIII Series aerial platform models listed on [Table 4.1](#).
 - **Equipment identified** with “ANSI” meets the ANSI SIA-A92.6-2006 standard.
 - **Equipment identified** with “CSA” meets the CSA B354.2-01 standard.
- b. **CSA (Canada)**

Operators are required to conform to national, territorial/provincial and local health and safety regulations applicable to the operation of this aerial platform.
- c. **ANSI/SIA (United States)**

Operators are required by the current ANSI/SIA A92.6 standards to read and understand their responsibilities in the manual of responsibilities before they use or operate this aerial platform.

**WARNING**

Failure to comply with your required responsibilities in the use and operation of the aerial platform could result in death or serious injury!

Operator Safety Reminders

A study conducted by St. Paul Travelers showed that most accidents are caused by the failure of the operator to follow simple and fundamental safety rules and precautions.

You, as a careful operator, are the best insurance against an accident. Therefore, proper usage of this aerial platform is mandatory. The following pages of this manual should be read and understood completely before operating the aerial platform.

Common sense dictates the use of protective clothing when working on or near machinery. Use appropriate safety devices to protect your eyes, ears, hands, feet and body.

Any modifications from the original design are strictly forbidden without written permission from SKYJACK.

Electrocution Hazard

This aerial platform is not electrically insulated. Maintain a Minimum Safe Approach Distance (MSAD) from energized power lines and parts as listed below. The operator must allow for the platform to sway, rock or sag. This aerial platform does not provide protection from contact with or proximity to an electrically charged conductor.

Per ANSI A92.6-2006 8.10(7)

“The operator shall perform only that work for which he or she is qualified, in compliance with all applicable safety related work practices intended to prevent electric shock covered by the Code of Federal Regulations (CFR) 1910.333. The operator’s level of competence shall be established only by persons qualified to do so. Operators shall maintain the appropriate minimum approach distance (MAD) from energized power lines and parts covered by CFR 1910.333 (c).”

Unqualified persons must maintain a minimum approach distance of 10 feet from any energized power line up to 50 kV. Energized power lines over 50 kV require a greater minimum approach distance to be maintained. Refer to CFR 1910.333.

As per CSA B354.2-01

“The operator shall maintain the minimum safe approach distance (MSAD) from energized conductors at all times in accordance with the authority having jurisdiction.”

**DO NOT USE THE AERIAL PLATFORM AS A GROUND FOR WELDING.
DO NOT OPERATE THE AERIAL PLATFORM DURING LIGHTNING OR STORMS.
DO NOT OPERATE THE AERIAL PLATFORM NEAR POWER LINES. MAINTAIN A MINIMUM SAFE APPROACH DISTANCE (MSAD) FROM ENERGIZED POWER LINES.**

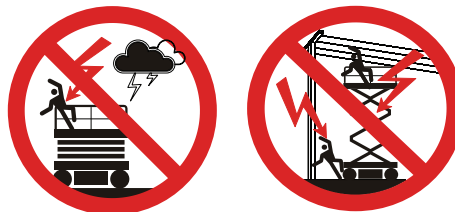

 DANGER Avoid Power Lines	
Minimum Safe Approach Distance	
ANSI/SIA A92.6-2006 & CSA B354.2-01 Requirements	
Voltage Range (Phase to Phase)	Minimum Safe Approach Distance (Feet)
0 to 300V	Avoid Contact
Over 300V to 50KV	10
Over 50KV to 200KV	15
Over 200KV to 350KV	20
Over 350KV to 500KV	25
Over 500KV to 750KV	35
Over 750KV to 1000KV	45
FAILURE TO AVOID THIS HAZARD WILL RESULT IN DEATH OR SERIOUS INJURY!	

60023AD-ANSI

Safety Precautions

Know and understand the safety precautions before going on to next section.



WARNING

Failure to heed the following safety precautions could result in tip over, falling, crushing, or other hazards leading to death or serious injury.

- **KNOW** all national, state or territorial/provincial and local rules which apply to your aerial platform and jobsite.
- **TURN** main power disconnect switch “○” off when leaving the aerial platform unattended. Remove the key to prevent unauthorized use of the aerial platform.
- **WEAR** all the protective clothing and personal safety devices issued to you or called for by job conditions.
- **DO NOT** wear loose clothing, dangling neckties, scarves, rings, wristwatches or other jewelry while operating this lift.



- **AVOID** entanglement with ropes, cords or hoses.



- **AVOID** falling. Stay within the boundaries of the guardrails.



- **DO NOT** raise the aerial platform or operate elevated in windy or gusty conditions that exceed the limits specified in Section 4, Table 4.5.



- **DO NOT** increase the lateral surface area of the platform. Increasing the area exposed to the wind will decrease aerial platform stability. Avoid tenting.



- **DO NOT** drive elevated on a soft or uneven surface.



- **DO NOT** elevate the aerial platform if it is not on a firm, level surface.



- **DO NOT** drive elevated near depressions or holes of any type, loading docks, debris, drop-offs or surfaces that may affect the stability of the aerial platform.

- **IF OPERATION IN AREAS WITH HOLES OR DROP-OFFS IS ABSOLUTELY NECESSARY**, elevated driving shall not be allowed. Position the aerial platform horizontally only with the platform fully-lowered. After ensuring that all 4 wheels or outriggers (if equipped) have contact with a firm, level surface, the aerial platform can be elevated. After elevation, the drive function must not be activated.



- **DO NOT** elevate or drive elevated on a slope. Elevated driving must be done on a firm, level surface.

- **DO NOT** ascend or descend a grade when elevated. When fully-lowered, ascend or descend grades up to maximum rated inclines listed in Table 4.3a and Table 4.3b.



Safety Precautions (Continued)

Know and understand the safety precautions before going on to next section.

- **DO NOT** operate on surfaces not capable of holding the weight of the aerial platform including the rated load, e.g. covers, drains, and trenches.

- **DO NOT** operate an aerial platform that has ladders, scaffolding or other devices mounted on it to increase its size or work height. It is prohibited.



- **DO NOT** exert side forces on aerial platform while elevated.



- **DO NOT** use the aerial platform as a crane. It is prohibited.



- **DO NOT** sit, stand or climb on the guardrails. It is prohibited.



- **DO NOT** climb on scissor arm assembly. It is prohibited.



- **AVOID** overhead obstructions. Be aware of overhead obstructions or other possible hazards around aerial platform when lifting or driving.



- **AVOID** crushing hazards. Be aware of crushing hazards when lifting or driving. Keep all body parts inside the aerial platform.



- **DO NOT** raise the aerial platform while the aerial platform is on a truck, fork lift or other device or vehicle.



- **DO NOT** lower the platform unless the area below is clear of personnel and obstructions.



- **ENSURE** that there are no personnel or obstructions in the path of travel, including blind spots.



- **BE AWARE** of blind spots when operating the aerial platform.

- **DO NOT** use with improperly inflated/damaged tires or wheels. Refer to [Section 2: Wheel/Tire Assembly](#).



- **ENSURE** ALL tires are in good condition and bolts are properly tightened.

- **DO NOT** alter or disable limit switches or other safety devices.

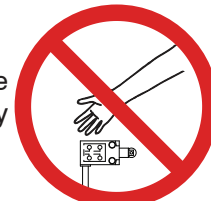

Safety Precautions (Continued)

Know and understand the safety precautions before going on to next section.

- **DO NOT** use the aerial platform without guardrails, locking pins and the entry gate(s) in place.

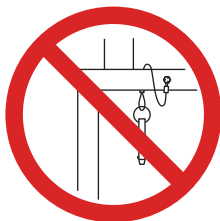

- **DO NOT** position the aerial platform against another object to steady the platform.

- **DO NOT** use under influence of alcohol or drugs.



- **DO NOT** place materials on the guardrails or materials that exceed the confines of the guardrails unless approved by Skyjack.

- **STUNT** driving and horseplay are prohibited.

- **DO NOT** exceed the rated capacity of the aerial platform.



- **DO NOT** distribute load unevenly.



- **DO NOT** operate if aerial platform is not working properly or if any parts are damaged or worn.



- **DO NOT** leave aerial platform unattended with key in key switch.



Safety Precautions (Continued)

Know and understand the safety precautions before going on to next section.

Fall Protection

As per the ANSI A92.6-2006 standard, “The guardrail system of the aerial platform provides fall protection. If occupant(s) of the platform are required to wear personal fall protection equipment (PFPE), occupants shall comply with instructions provided by the aerial platform manufacturer (remanufacturer) regarding anchorage(s).”

If additional fall protection is required, by an employer or the authority having jurisdiction, Skyjack recommends the use of a fall restraint system to keep an occupant within the confines of the platform, and thus not expose the occupant to any fall hazard requiring a fall arrest.

All personal fall protection equipment must comply with applicable governmental regulations and must be inspected and used in accordance with the manufacturer’s recommendations.

All personal fall protection equipment must be attached only to approved anchorage points within the platform of the aerial platform.



WARNING

Entering and exiting the aerial platform should only be done using the three points of contact.

- **Use only equipped access openings.**
- **Enter and exit only when the aerial platform is in the fully retracted position.**
- Do use three points of contact to enter and exit the platform. Enter and exit the platform from the ground only. Face the aerial platform when entering or exiting the platform.
- Three points of contact means that two hands and one foot or one hand and two feet are in contact with the aerial platform or the ground at all times during entering and exiting.



WARNING

An operator should not use any aerial platform that:

- **does not appear to be working properly.**
- **has been damaged or appears to have worn or missing parts.**
- **has alterations or modifications not approved by the manufacturer.**
- **has safety devices which have been altered or disabled.**
- **has been tagged or locked out for non-use or repair.**

Failure to avoid these hazards could result in death or serious injury.

Jobsite Inspection

- Do not use in hazardous locations (see NFPA 505).
- Perform a thorough jobsite inspection prior to operating the aerial platform, to identify potential hazards in your work area.
- Be aware of moving equipment in the area. Take appropriate actions to avoid collision.

2.1 Familiarization of SJIII Series



WARNING

Aerial Platform Familiarization should be given only to individuals who are QUALIFIED And TRAINED to operate an aerial platform.

Do not operate this aerial platform without proper authorization and training. Failure to avoid this hazard could result in death or serious injury.

It is the responsibility of the operator to read, completely understand and follow all instructions and warnings contained in this operating manual and on the aerial platform.

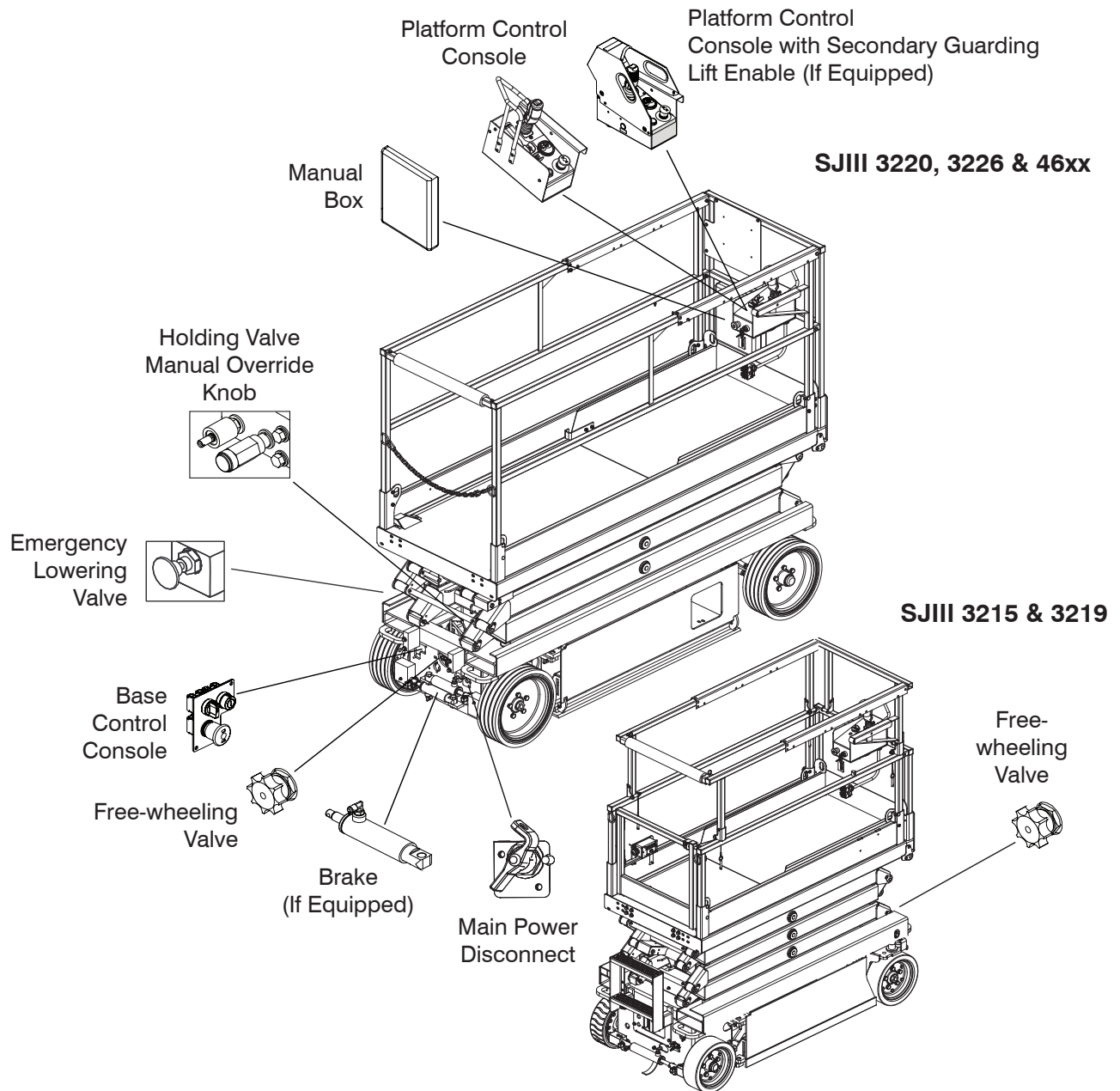

FAMILIARIZATION

2.2 Component Identification

The following descriptions are for identification, explanation and locating purposes only.

2.2-1 Main Power Disconnect Switch

This switch is located at the rear of the base.

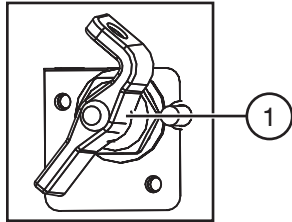

Figure 2-1. Main Power Disconnect Switch

1. **Main Power Disconnect Switch** - This switch, when in “○” off position, disconnects power to all circuits. Switch must be in “|” on position to operate any circuit. Turn switch “○” off when transporting aerial platform.

2.2-2 Tilt Alarm

The aerial platform is equipped with a device which senses when the aerial platform is out of level in any direction. When activated, it disables drive and lift functions of the aerial platform and an alarm produces an audible sound accompanied by the amber light (if equipped).



WARNING

If the tilt alarm sounds and the platform does not, or only partially raises, immediately lower the platform completely and ensure that the aerial platform is on a firm level surface.

2.2-3 Base Control Console

This control console is located at the rear of the base. It contains the following controls:

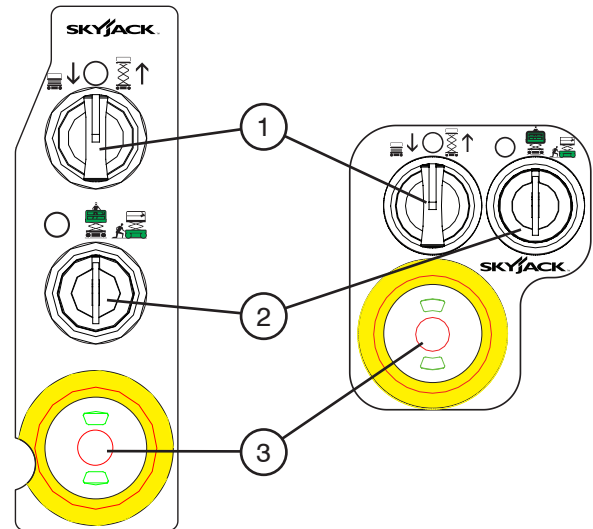
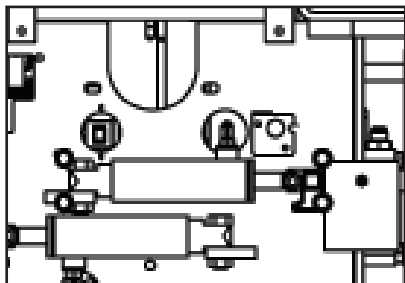

Figure 2-2. Base Control Console

1. **Lower/Neutral/Raise Switch** - This switch controls “↑” raising or “↓” lowering of platform.
2. **Off/Platform/Base Key Switch** - This three-way switch allows the operator to turn “○” off power to aerial platform or to activate either “|” platform or “|” base controls.
3. **Emergency Stop Button** - This button “●”, when depressed, disconnects power to the control circuit.

2.2-4 Brake System

The brake system is located at the rear of the base. The brakes must be manually disengaged before pushing, winching or towing. Refer to [Section 2.5-2](#) for procedure on how to release brakes manually. The system contains the following controls:



Pin Brakes (If Equipped)

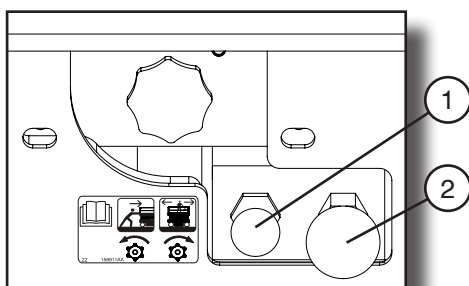

Disc Brakes (If Equipped)

Figure 2-3. Brake System

1. Brake auto reset valve plunger
2. Brake hand pump

2.2-5 Free-wheeling Valve

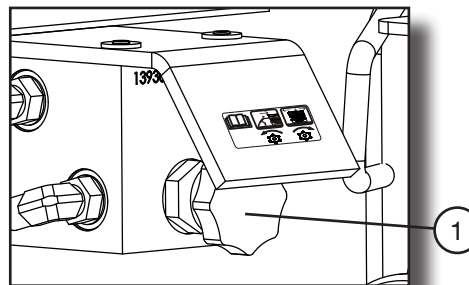

Models 3215 and 3219

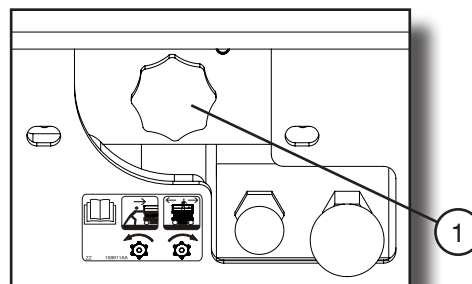

Models 3220, 3226 and 46xx

Figure 2-4. Free-wheeling Valve

1. **Free-wheeling Valve** - The free-wheeling valve is located at the front and/or rear of the aerial platform (depending on the model). Refer to [Section 2.5-1](#) for procedure on how to release the free-wheeling valve.

2.2-6 Emergency Lowering System

This emergency lowering system allows platform lowering in the event of an emergency or an electrical system failure. Refer to [Section 2.6](#) for the emergency lowering procedure. The system contains the following controls:

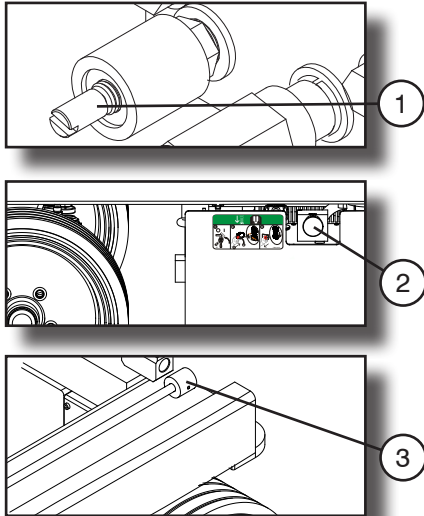

Figure 2-5. Emergency Lowering System

1. **Holding Valve Manual Override Knob** - Located on the holding valve at the bottom of each lift cylinder.
2. **Emergency Lowering Valve** - Located at the rear of the hydraulic/electric tray.
3. **Emergency Lowering Access Rod** (3226, 4626, & 4632) - Located at the left side of the base.

2.2-7 Platform Control Console

This removable control console is mounted at the right front of the platform. It contains the following controls:

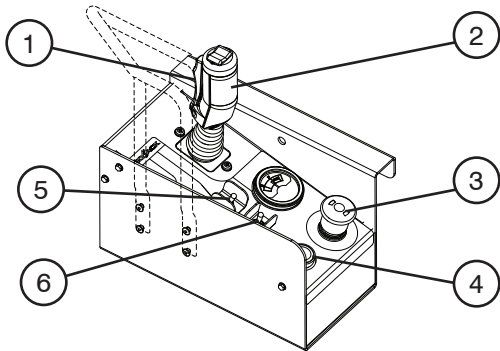









Figure 2-6. Platform Control Console

1. **Lift/Drive/Steer Enable Trigger Switch** - This momentary “” switch energizes the controller. It must be held depressed continuously while engaging either the lift/drive or steer functions.
2. **Lift/Drive/Steer Controller** - This one-hand lever controls lift/drive and steer motions. Internal springs return it to neutral when controller is released.
3. **Emergency Stop Button/Operation Light** - This button “”, when depressed, disconnects power to the control circuit. The operation light indicates upper control availability. It glows when both emergency stop buttons on the platform control console and the base control console are pulled out.

4. **Horn Push Button** - This “” push button sounds an automotive-type horn.
5. **Inclined Drive/Level Drive Switch** - This switch selects “” inclined drive (low speed/high torque) or “” level drive (high speed/low torque).

NOTE

Inclined drive (low speed/high torque) is not available on 3215 and 3219 models.

6. **Lift/Off/Drive Switch** - Selecting “” off position disconnects power from both lift and drive circuits. Selecting “” lift position energizes the lift circuit. Selecting “” drive position energizes the drive circuit.



WARNING

Skyjack scissor lifts are to be operated from the operator's position on the platform with the control box secured on the mounting bracket at the front right portion of the platform. Operation of the unit from the ground is permissible only when maintaining the lift or, in limited circumstances, when an obstruction precludes the safe operation of the lift from the operator's position on the platform. Operation from the ground is to be performed as set forth in the Operating Manual.

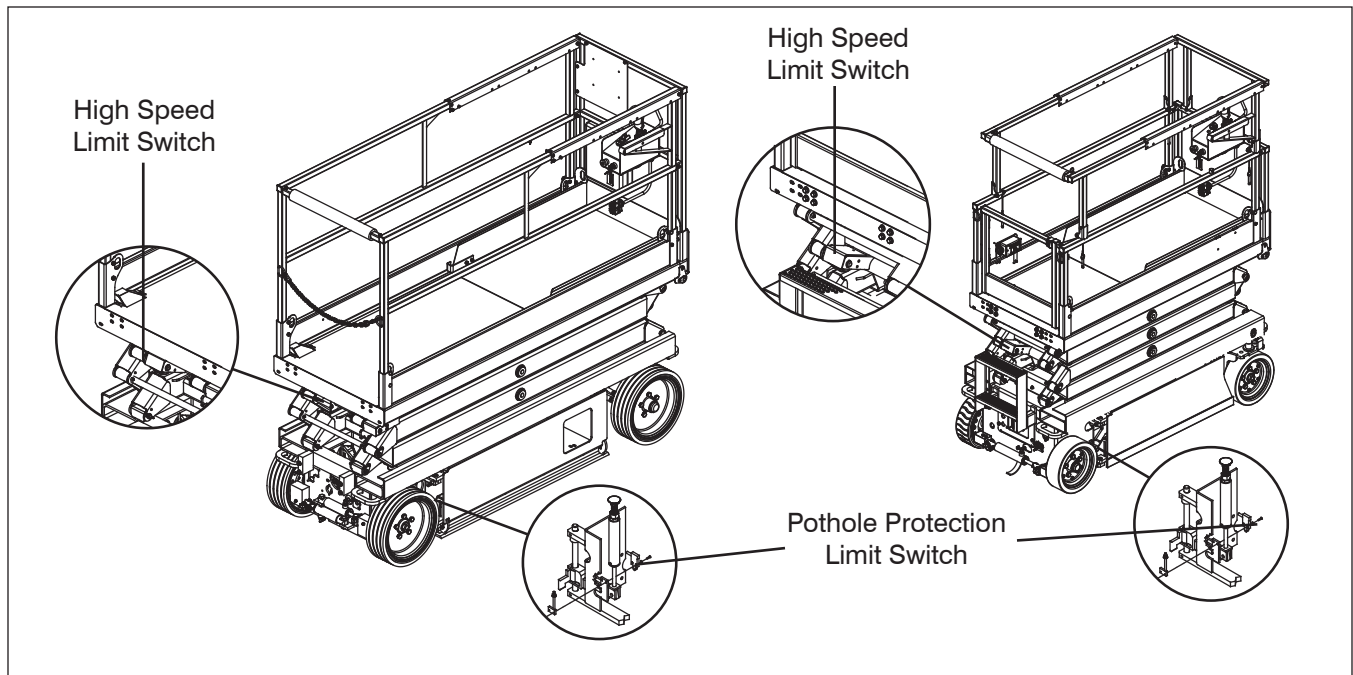

2.3 Visual & Daily Maintenance Inspections

Begin the visual and daily maintenance inspections by checking each item in sequence for the conditions listed in this section.

WARNING

To avoid injury, do not operate an aerial platform until all malfunctions have been corrected.

WARNING

To avoid possible injury, ensure aerial platform power is off during your visual and daily maintenance inspections.

CAUTION

Ensure aerial platform is on a firm, level surface.

NOTE

While performing visual and daily inspections in different areas, be aware to also inspect limit switches, electrical and hydraulic components.

2.3-1 Labels

Refer to [Section 5 - Labels](#) in this manual and determine that all labels are in place and are legible.

2.3-2 Electrical

Maintaining the electrical components is essential to good performance and service life of the aerial platform.

Inspect the following areas for chafed, corroded and loose wires:

- base to platform cables and wiring harness
- battery tray wiring harnesses
- hydraulic/electrical wiring harnesses

2.3-3 Limit Switches

Ensure limit switches are properly secured with no signs of visible damage and movement is not obstructed.

2.3-4 Hydraulic

Maintaining the hydraulic components is essential to good performance and service life of the aerial platform.

Perform a visual inspection around the following areas:

- hoses and fittings
- all hydraulic cylinders
- all hydraulic manifolds
- the underside of the base
- ground area under the aerial platform

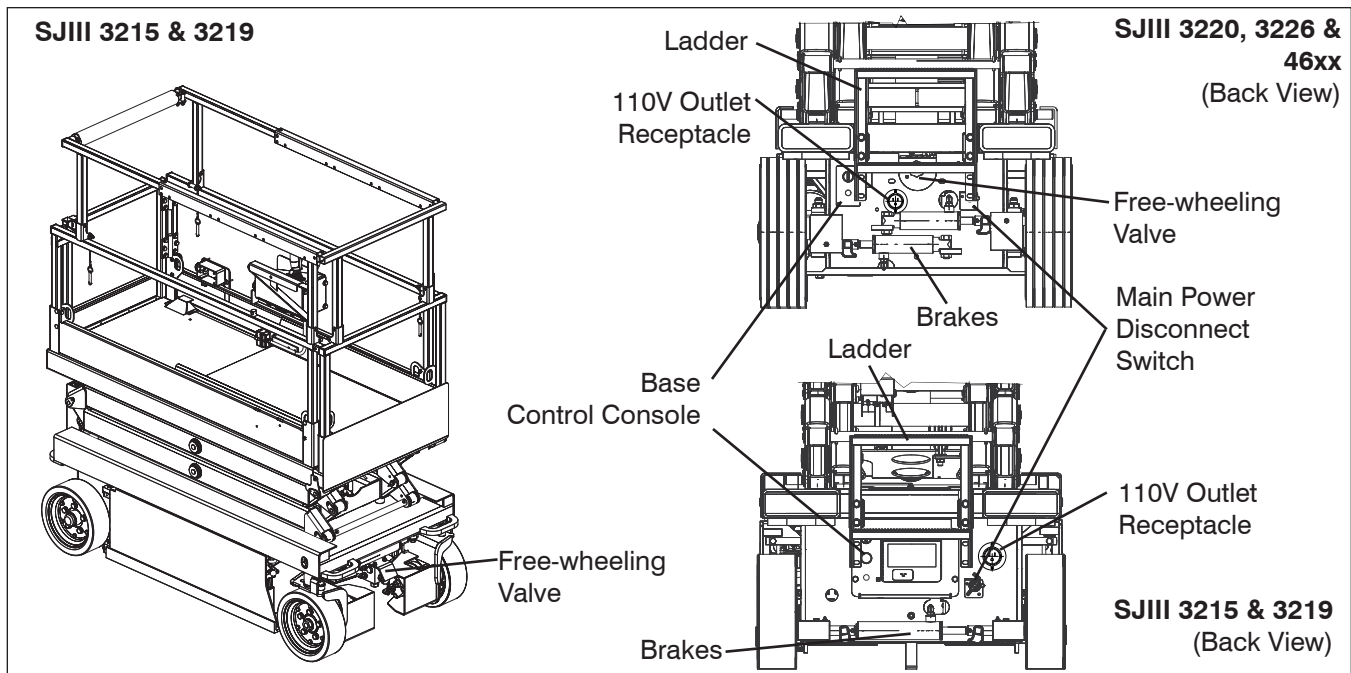

2.3-5 Entrance Side

- **Main Power Disconnect Switch**
 - Turn main power disconnect switch to “○” off position.
 - Ensure all cables are secure and switch is in proper working condition.
- **Base Control Switches**
 - Ensure there are no signs of visible damage and all switches are in their neutral positions.
- **Free-wheeling Valve Knob**
 - Ensure there are no loose or missing parts and there is no visible damage.
- **Brakes**
 - Ensure there are no loose or missing parts and there is no visible damage.
 - Ensure tabs are not locked.
- **110V Outlet Receptacle**
 - Ensure receptacle is free from dirt and obstructions.
- **Ladder**
 - Ensure there are no loose or missing parts and there is no visible damage.

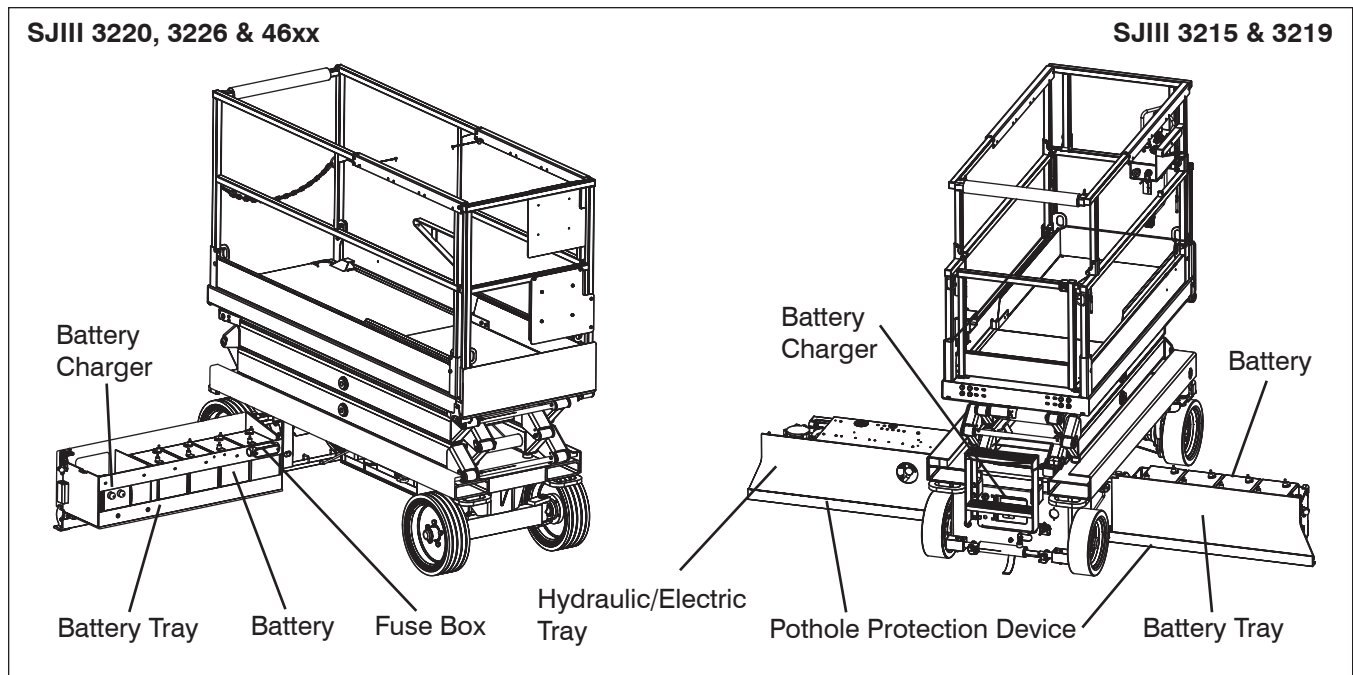

2.3-6 Battery Tray Side

- **Pothole Protection Device**
 - Ensure mechanisms have no sign of visible damage and are free from dirt and obstructions.
- **Battery Tray**
 - Ensure tray latch is secure and in proper working order.
- **Battery Charger**
(SJIII 3215 & 3219 - Entrance Side)
 - Ensure charger is secure and shows no visible damage.
- **Battery**
Proper battery condition is essential to good performance and operational safety. Improper fluid levels or damaged cables and connections can result in component damage and hazardous conditions.



WARNING

Battery acid is extremely corrosive - Wear proper eye and facial protection as well as appropriate protective clothing. If contact occurs, immediately flush with cold water and seek medical attention.

1. Check battery case for damage.
2. Clean battery terminals and cable ends thoroughly with a terminal cleaning tool or wire brush.
3. Ensure all battery connections are tight.
4. If applicable, check battery fluid level. If plates are not covered by at least 1/2" (13 mm) of solution, add distilled or demineralized water.
5. Replace battery if damaged or incapable of holding a lasting charge.



WARNING

Explosion hazard. Keep flames and sparks away. Do not smoke near batteries.



WARNING

Use original or manufacturer-approved parts and components for the aerial platform.

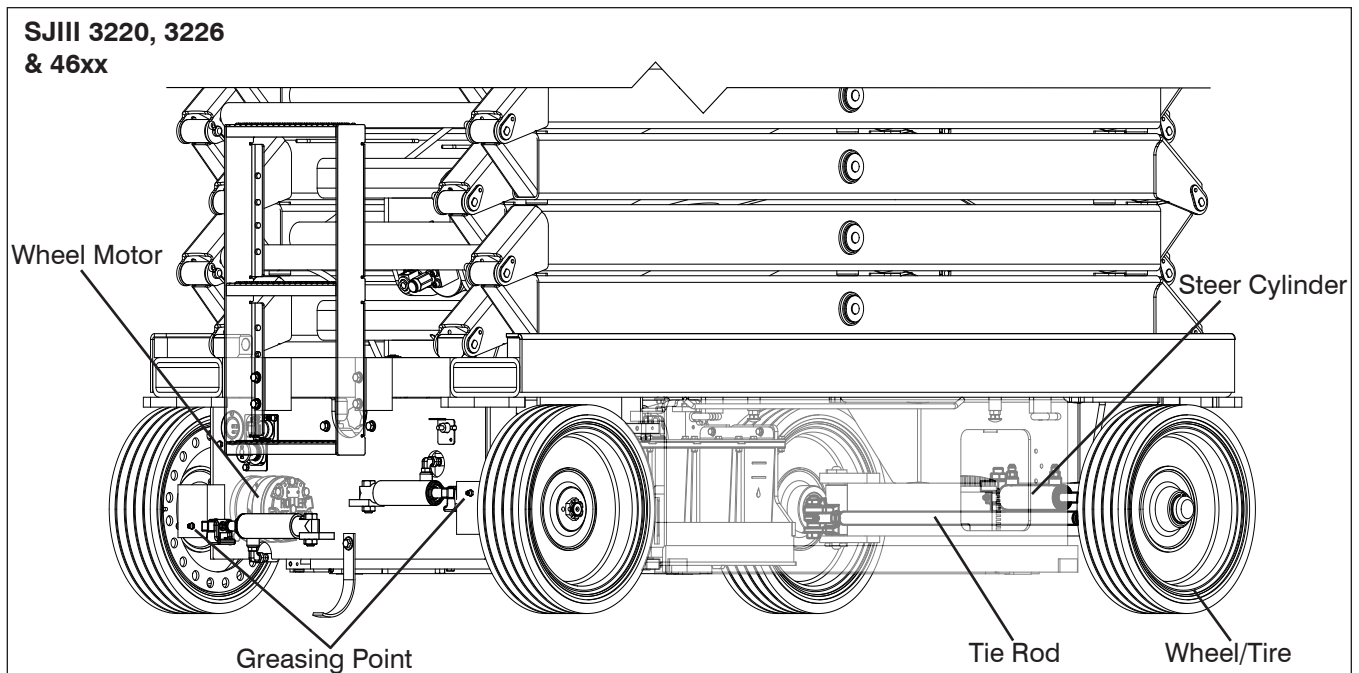

- **Steer Cylinder Assembly**
 - Ensure steer cylinder assembly is properly secured and there are no loose or missing parts.
- **Wheel/Tire Assembly**

The aerial platform is either equipped with solid rubber tires or foam-filled tires. Tire and/or wheel failure could result in an aerial platform tip-over. Component damage may also result if problems are not discovered and repaired in a timely fashion.

 - Check all tire treads and sidewalls for cuts, cracks, punctures and unusual wear.
 - Check each wheel for damage and cracked welds.
 - Ensure the castle nut (if equipped) is in place with the cotter pin.
 - Ensure the wheel nut is tight.
 - Check wheel motor assembly for loose or missing parts and signs of visible damage.
 - Ensure wheels are aligned and true vertically and horizontally.



WARNING

Intermixing tires of different types or using tires of types other than those originally supplied with this equipment can adversely affect stability. Therefore, replace tires only with the exact Skyjack-approved type. Failure to operate with matched approved tires in good condition may result in death or serious injury.

- **Tie Rod (SJIII 3220, 3226 & 46xx)**
 - Ensure there are no loose or missing parts, tie rod end studs are locked and there is no visible damage.
- **Greasing Points**
 - Ensure greasing points have no sign of visible damage and are free from dirt and obstructions.

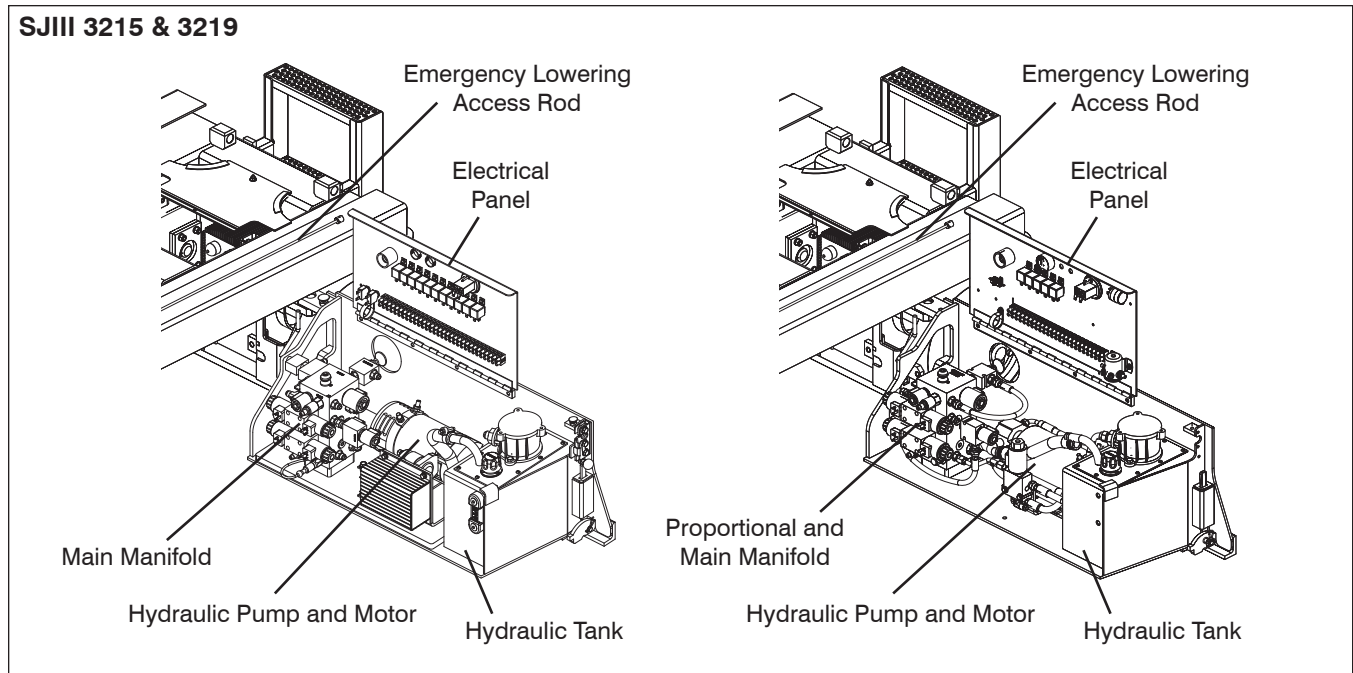

2.3-7 Hydraulic/Electric Tray Side

- Ensure tray latch is secure and in proper working order.
- **Pothole Protection Device**
 - Ensure mechanisms have no sign of visible damage and are free from dirt and obstructions.
- **Hydraulic Tank**
 - Ensure hydraulic filler cap is secure.
 - Ensure tank shows no visible damage and no evidence of hydraulic leakage.
- **Hydraulic Oil**
 - Ensure platform is fully lowered, and then visually inspect the sight gauge located on the side of the hydraulic oil tank.
 - The hydraulic oil level should be at or slightly above the top mark of the sight glass.
- **Hydraulic Pump and Motor**
 - Ensure there are no loose or missing parts and there is no visible damage.
- **Electrical Panel**
 - Ensure panel is properly secured and there is no visible damage.
 - Ensure there are no loose wires or missing fasteners.

- **Main Manifold**
 - Ensure all fittings and hoses are properly tightened and there is no evidence of hydraulic leakage.
 - Ensure there are no loose wires or missing fasteners.
- **Proportional and Main Manifolds (If equipped)**
 - Ensure all fittings and hoses are properly tightened and there is no evidence of hydraulic leakage.
 - Ensure there are no loose wires or missing fasteners.
- **Emergency Lowering Access Rod (If Equipped)**
 - Ensure rod is properly secured and there is no visible damage.

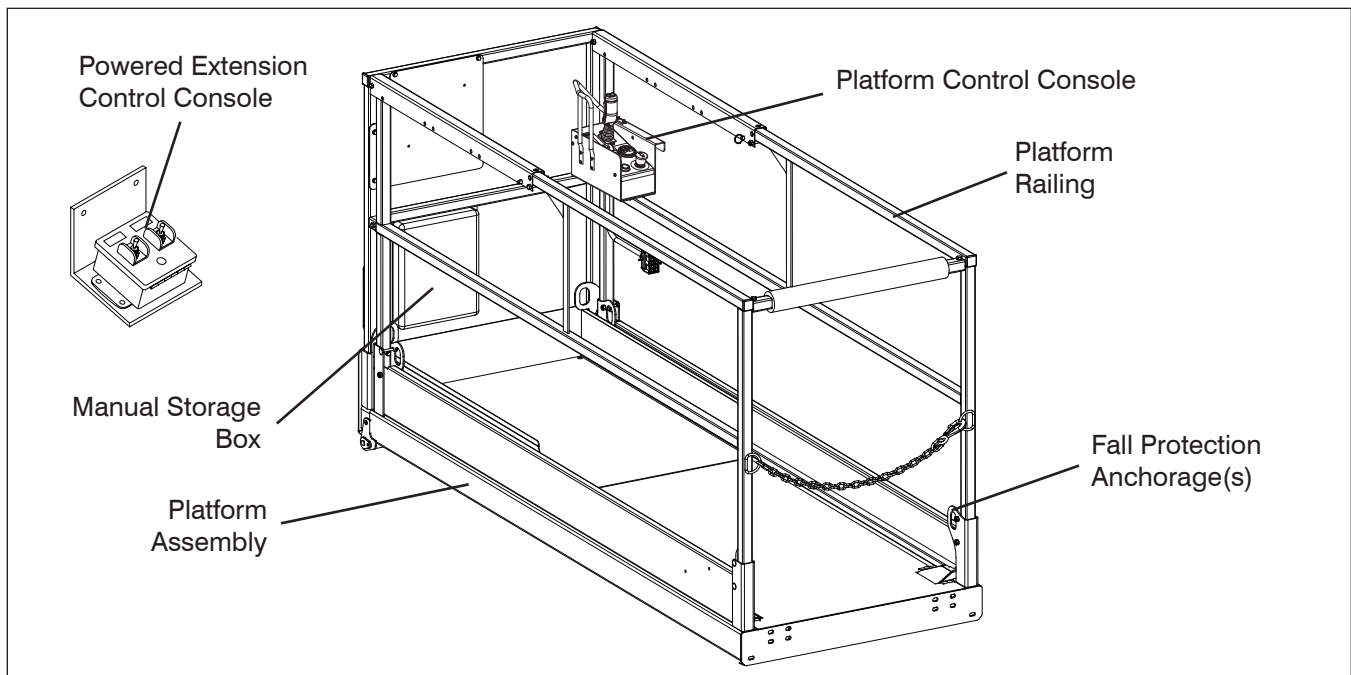

2.3-8 Platform Assembly



WARNING

Ensure that you maintain three points of contact to mount/dismount platform.

1. Use the ladder of aerial platform to access platform.
2. Close the gate.
 - Ensure there are no loose or missing parts and there is no visible damage.
 - Ensure all fasteners are securely in place.
 - Ensure all railings are properly positioned and secured.
 - Ensure gate is in good working order.
- **Fall Protection Anchorage(s)**
 - Ensure anchorage(s) are secure and there is no visible damage.
- **AC Outlet on Platform**
 - Ensure outlet has no visible damage and free from dirt or obstructions.
- **Platform Control Console**
 - Ensure all switches and controller are returned to neutral and are properly secured.

- Ensure there are no loose or missing parts and there is no visible damage.

- **Manuals**

Ensure a copy of operating manual and ANSI/CSA certificate are enclosed in manual storage box.

- Check to be sure manual storage box is present and in good condition.
- Ensure manuals are legible and in good condition.
- Always return manuals to the manual storage box after use.

- **Powered Extension Control Console (If Equipped)**

- Ensure all switches are returned to neutral and are properly secured.
- Ensure there are no loose or missing parts and there is no visible damage.



WARNING

Ensure that you maintain three points of contact to mount/dismount platform.

3. Use the ladder to dismount from platform.

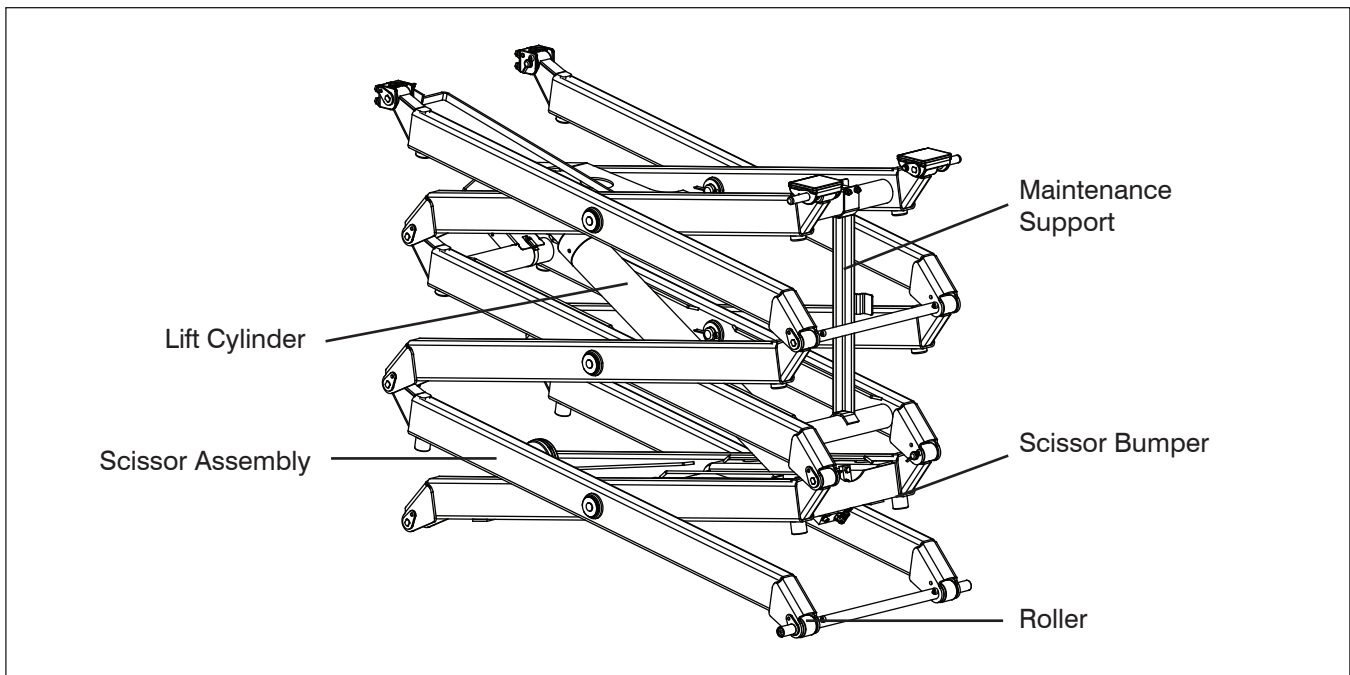

2.3-9 Lifting Mechanism

1. Raise the platform (refer to [Section 3.8-2](#)) until there is adequate clearance to swing down the maintenance support (refer to [Section 3.12](#)).
 - Maintenance Support
 - Ensure maintenance support is properly secured and shows no visible damage.
 - Scissor Assembly
 - Ensure scissor assembly shows no visible damage and no signs of deformation in weldments.
 - Make sure all the pins and fasteners are correctly installed, including the connections to the base and platform.
 - Ensure cables and wires are properly routed and shows no signs of wear and/or physical damage.
 - Scissor Bumpers
 - Ensure bumpers are secure and shows no sign of visible damage.
 - Rollers
 - Ensure rollers are secure and there is no visible damage.
 - Ensure rollers' path of travel are free from dirt and obstructions.

- Lift Cylinder(s)
 - Ensure each lift cylinder is properly secured, there are no loose or missing parts and there is no evidence of damage.
 - Ensure all fittings and hoses are properly tightened and there is no evidence of hydraulic leakage.
2. Raise the platform until there is adequate clearance to swing up the maintenance support.
 3. Swing up maintenance support into storage bracket.
 4. Fully lower the platform.

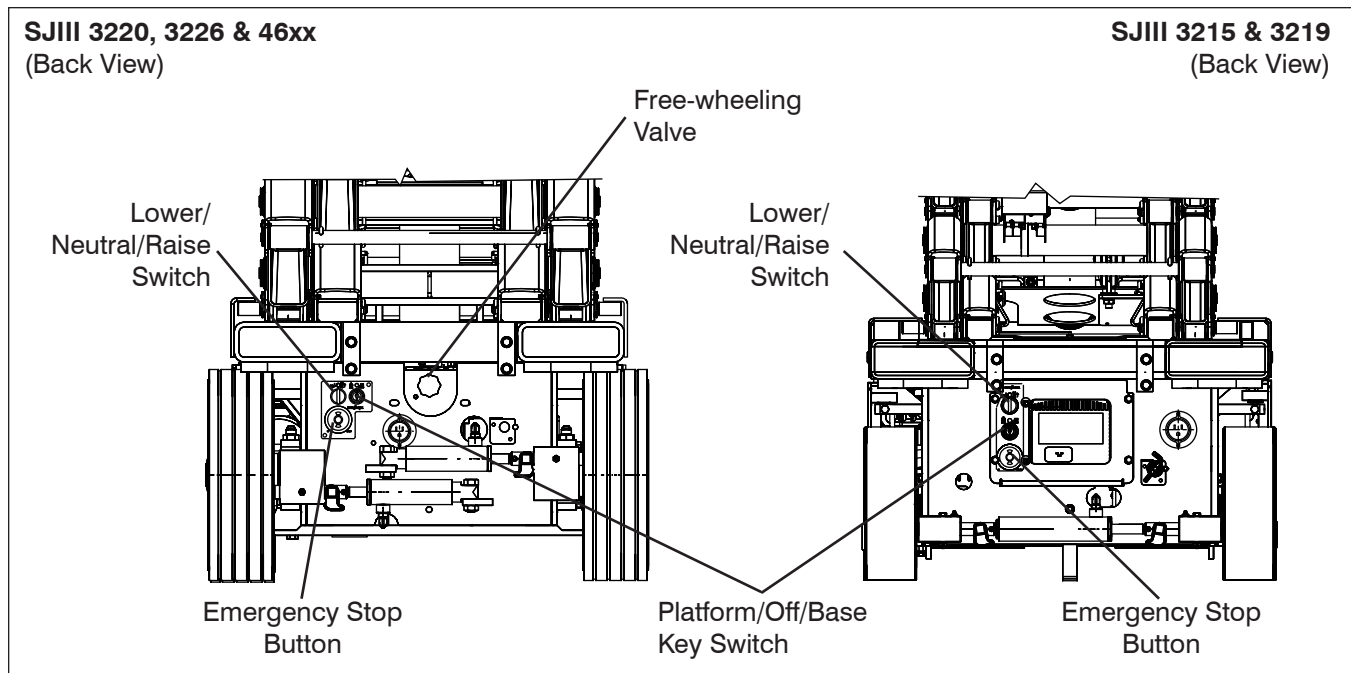

2.4 Function Tests

Function tests are designed to discover any malfunctions before aerial platform is put into service. The operator must understand and follow step-by-step instructions to test all aerial platform functions.



WARNING

Never use a malfunctioning aerial platform. If malfunctions are discovered, aerial platform must be tagged and placed out of service. Repairs to aerial platform may only be made by a qualified service technician.

After repairs are completed, operator must perform a pre-operation inspection and a series of function tests again before putting aerial platform into service.

Prior to performing function tests, be sure to read and understand [Section 3.8 - Start Operation](#).

2.4-1 Test Main Power Disconnect Switch

1. At rear of the base, turn main power disconnect switch to "O" off position.
Result: Aerial platform functions should not operate.

2.4-2 Base Control Console





WARNING

Ensure that you maintain three points of contact when using the ladder to mount/dismount platform.

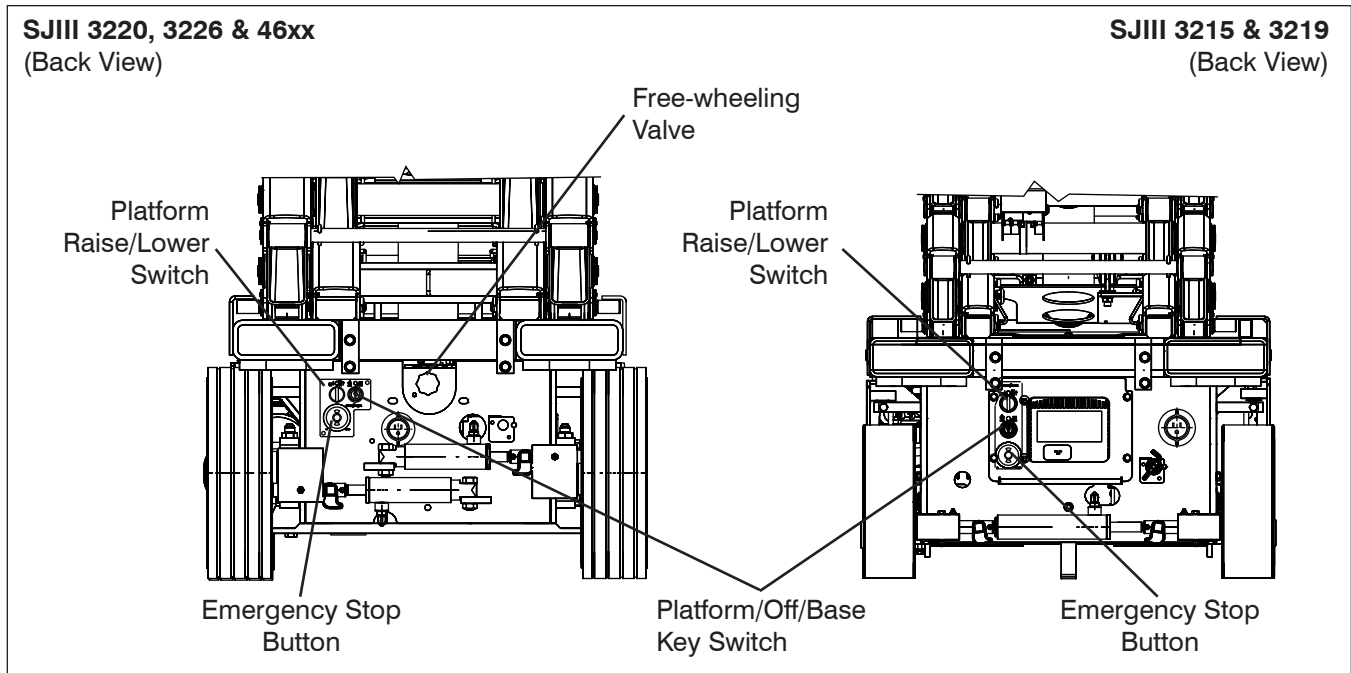
1. Use the ladder of aerial platform to access platform.
2. Close the gate.
3. On platform control console, pull out "E" emergency stop button.
4. Use the ladder to dismount from platform.
5. Turn main power disconnect switch to "I" on position.



• **Test Base Emergency Stop**



1. Push in “” emergency stop button and attempt to raise or lower the platform.
Result: Platform raising and lowering functions should not operate.
2. Pull out base “” emergency stop button.

3. Select and hold off/platform/base key switch to “” base position. Attempt to raise or lower the platform.
Result: Platform raising and lowering functions should operate.





• **Test Off/Platform/Base Switch**



WARNING
Be aware of overhead obstructions or other possible hazards around the aerial platform when lifting.

1. Select off/platform/base key switch “” off position. Attempt to raise or lower the platform.
Result: Platform raising and lowering functions should not operate.
2. Select off/platform/base key switch to “” platform position. Attempt to raise or lower the platform.
Result: Platform raising and lowering functions should not operate.

• **Test Lower/Neutral/Raise Switch**

1. Select and hold off/platform/base key switch to “” base position and “” raise the platform with lower/neutral/raise switch.
Result: Platform should rise.
2. Select and hold off/platform/base key switch to “” base position and “” lower the platform with lower/neutral/raise switch.
Result: Platform should lower.

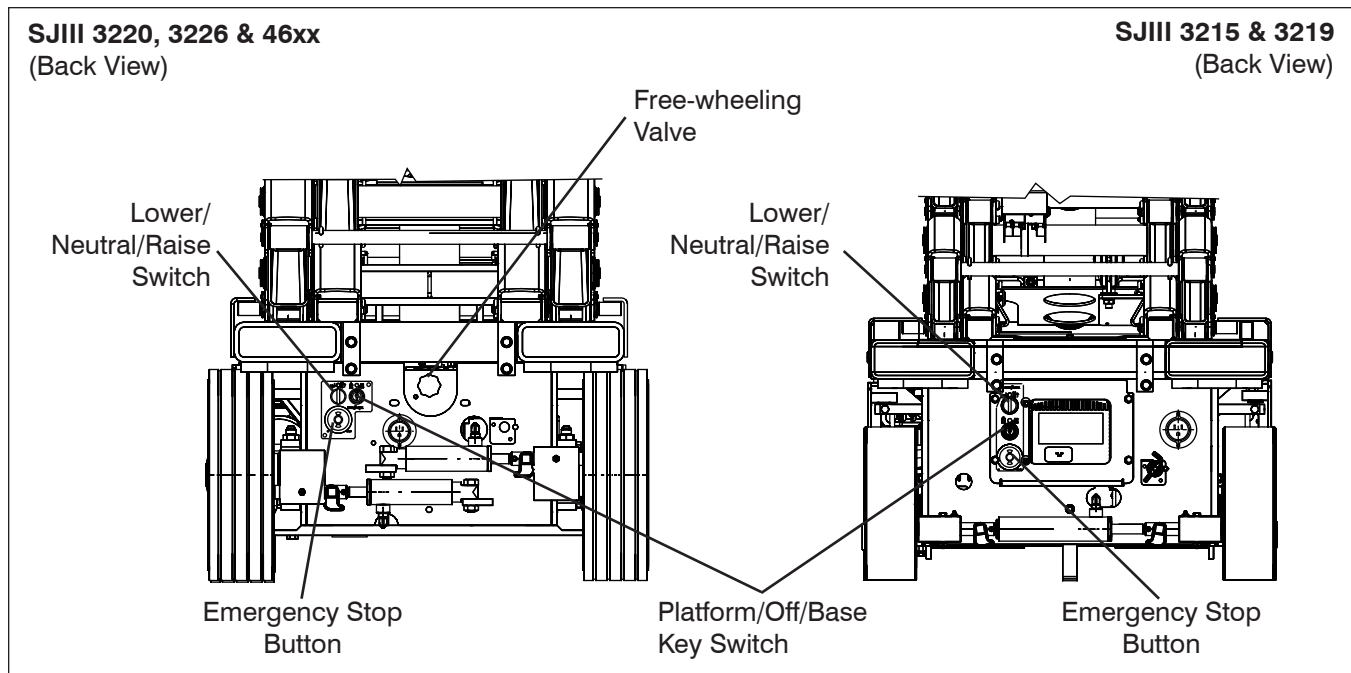

- Test Emergency Lowering

1. Raise the platform.
2. Turn main power disconnect switch to “○” off position.
3. Locate holding valve manual override knob at the base of each lift cylinder. Depress and turn counterclockwise. If necessary, use access rod that is located on the base of the aerial platform.
4. On hydraulic/electric tray, pull out and hold emergency lowering valve to fully lower the platform.
Result: The platform should lower.
5. To restore normal operation, depress and turn holding valve manual override knobs clockwise.

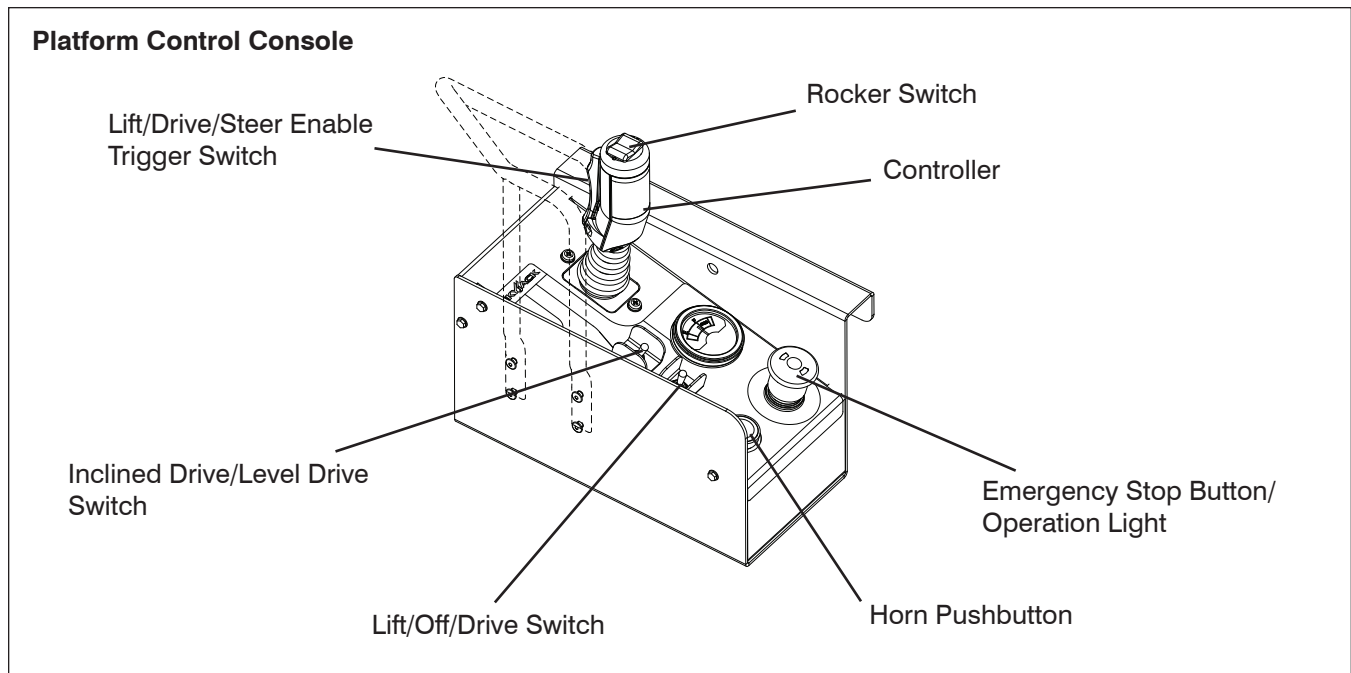

- Test Free-wheeling

1. Ensure path of intended motion is clear.
2. Release the brake manually (refer to [Section 2.5-2](#)).
3. Turn free-wheeling valve knob counterclockwise to a fully opened position and attempt to push/pull the aerial platform.
Result: Platform should move.
4. Turn free-wheeling valve knob clockwise to a fully closed position for normal operation.
5. Reengage the brake (refer to [Section 2.5-2](#)).



2.4-3 Platform Control Console

Result: All selected platform functions should not operate.

1. Ensure base “” emergency stop button is pulled out.
2. Select off/platform/base key switch to “” platform position.
3. Ensure main power disconnect switch is in “” on position.

• **Test Enable Trigger Switch**

1. Pull out “” emergency stop button.
2. Without activating “” enable trigger switch, attempt to activate any platform function.
Result: All platform functions should not operate.







WARNING

Ensure that you maintain three points of contact when using the ladder to mount/dismount platform.

• **Test Steering**

4. Use the ladder of aerial platform to access platform.
5. Close the gate.
6. On platform control console, pull out “” emergency stop button.

1. Select lift/off/drive switch to “” drive position.
2. Activate and hold “” enable trigger switch.
3. Press rocker switch on top of controller handle to “” left and “” right.
Result: Steer wheels should turn left and right.

• **Test Platform Emergency Stop**

1. Push in “” emergency stop button and attempt to activate any platform function.

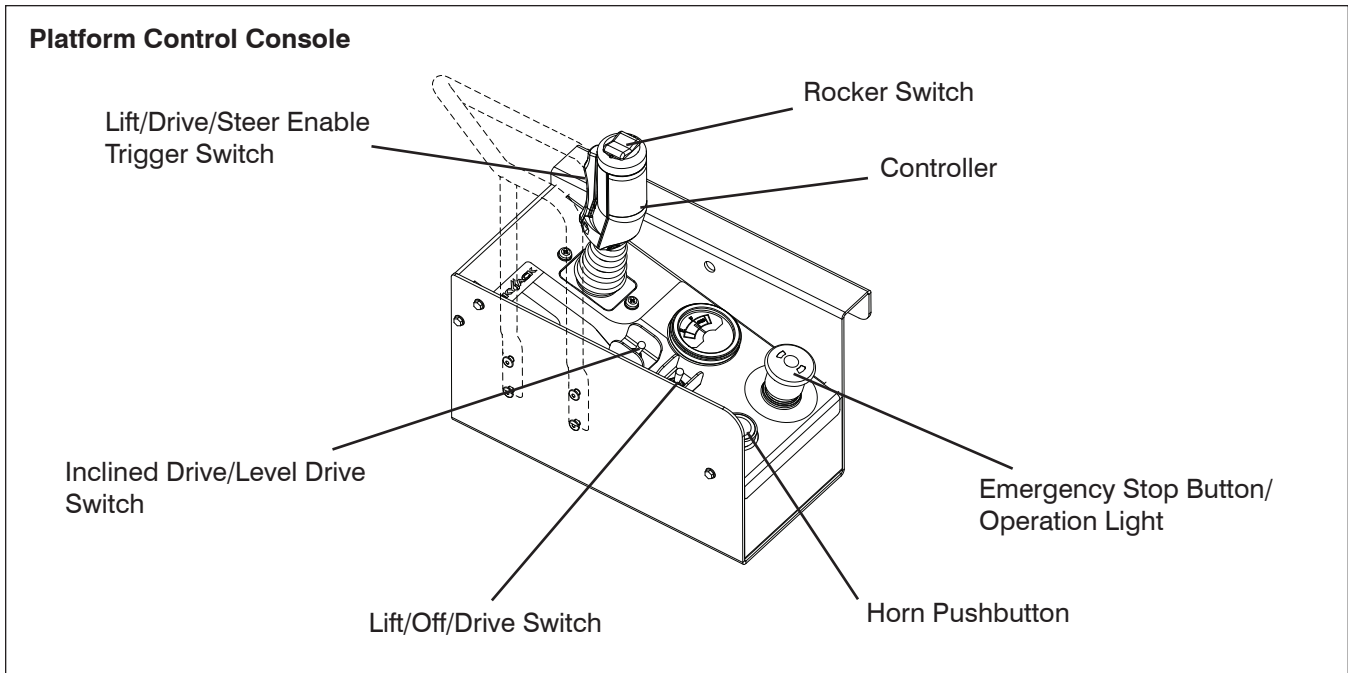

• **Test Driving**

1. Ensure path of intended motion is clear.
2. Activate and hold “” enable trigger switch.
3. Slowly move controller handle in “” forward direction until aerial platform begins to move, and then return handle to center position.
Result: Aerial platform should move in forward direction, and then come to a stop.
4. Slowly move controller handle in “” reverse direction until aerial platform begins to move, and then return handle to center position.
Result: Aerial platform should move in reverse direction, and then come to a stop.

• **Test Brakes**



Brakes will engage instantly when you release the controller handle, causing aerial platform to stop immediately.

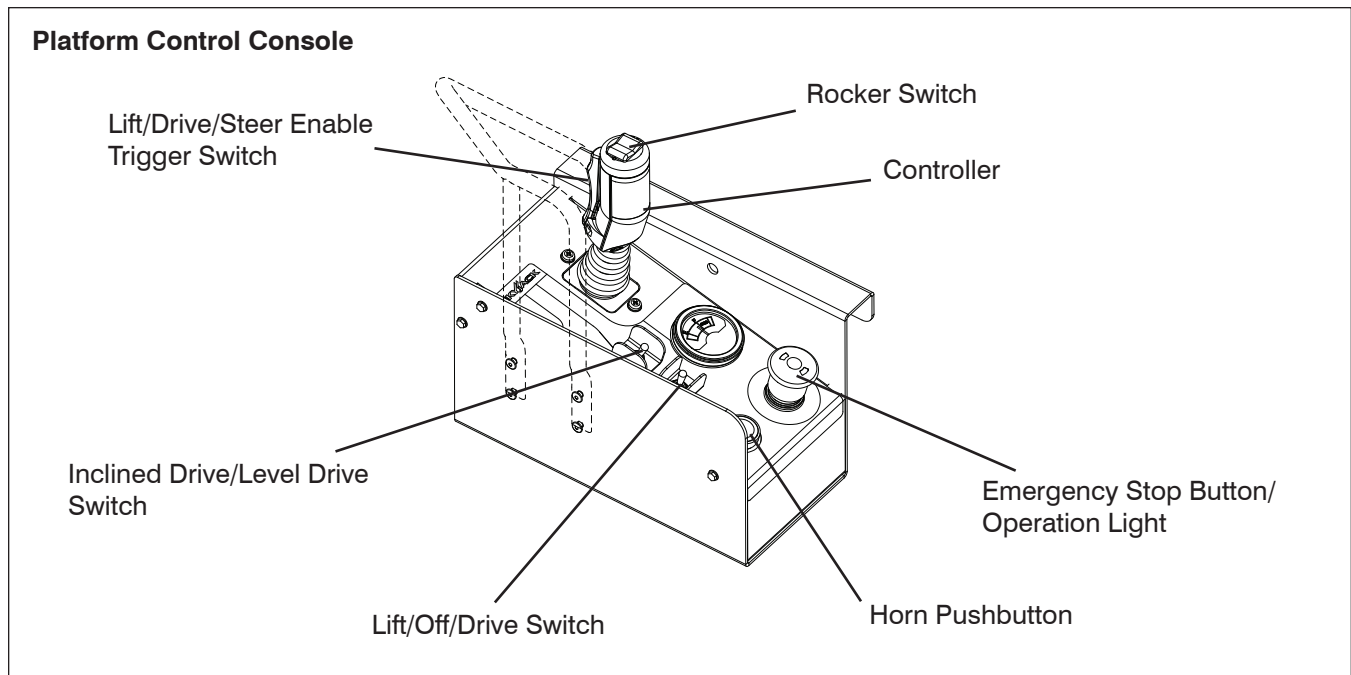

1. Ensure path of intended motion is clear.
2. Activate and hold “” enable trigger switch.
3. Drive aerial platform “” forward and then “” backward. Test brake by releasing controller handle.
Result: Aerial platform should come to a stop. If aerial platform pulls to one side while stopping, do not operate aerial platform until brake adjustments have been checked.
4. Drive aerial platform “” forward and then “” backward. Test brake again by releasing “” enable trigger switch only.
Result: Aerial platform should come to an instant and abrupt stop. If aerial platform does not stop immediately, or if aerial platform pulls to one side while stopping, do not operate aerial platform until brake adjustments have been checked.



- Test Platform Raising/Lowering



WARNING
 Be aware of overhead obstructions or other possible hazards around the aerial platform when lifting.

1. Select lift/off/drive switch to “ lift position.
2. Activate and hold “ enable trigger switch.
3. Push controller handle and raise the platform to an approximate height of 1 ft. (30.5 cm).
Result: Platform should rise.
4. Pull controller handle and lower the platform fully.
Result: Platform should lower.

- Test Horn

1. Push “ horn push button.
Result: Horn should sound.

- Test Pothole Sensor



WARNING
 Ensure that you maintain three points of contact to mount/dismount platform.

1. Use the ladder to dismount from platform and place a block, approximately 1.5” (3.75 cm), under the hydraulic/electric tray.
2. Use the ladder of aerial platform to access platform.
3. Close the gate.
4. Raise the platform until approximately a height of 7 feet (2 meters) is reached and attempt to drive forward or reverse.
Result: Aerial platform should not move forward or backward.

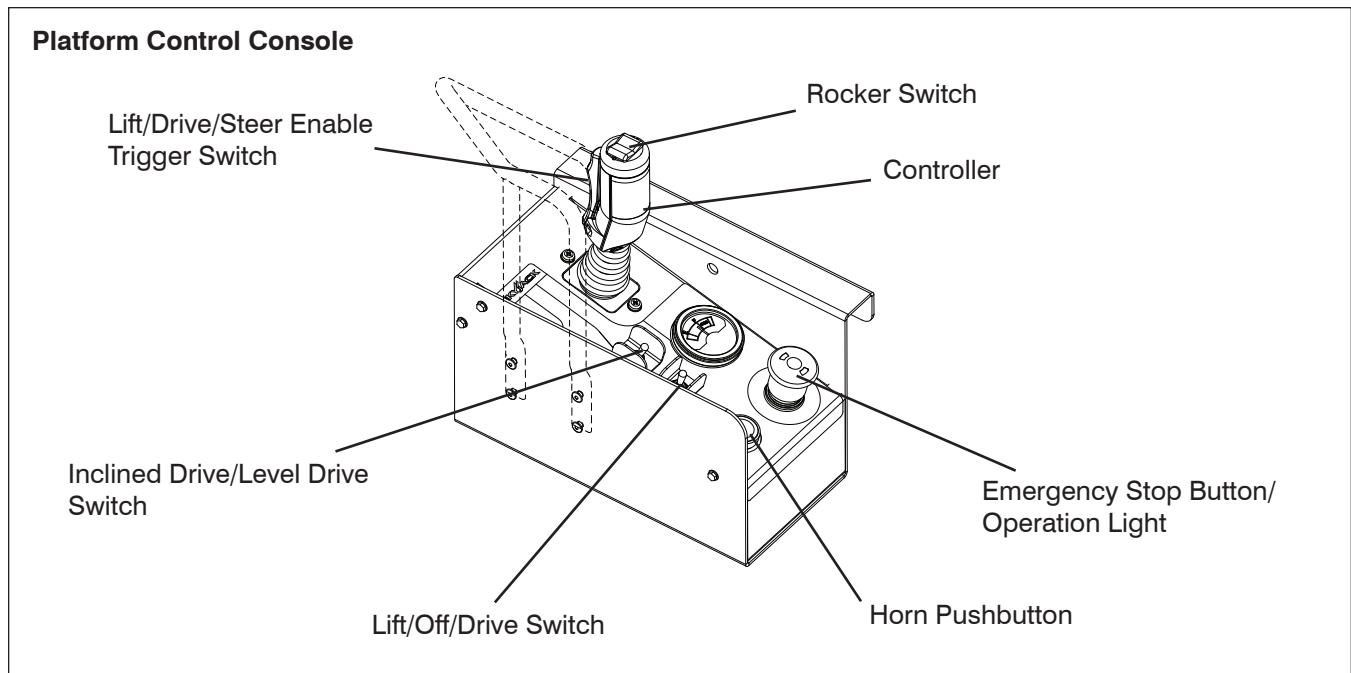

- Repeat the steps above with block placed under battery tray.
Result: Aerial platform should not move forward or backward.

- Test Elevated Drive Speed



Be aware of overhead obstructions or other possible hazards around the aerial platform when lifting.

- Ensure path of intended motion is clear.
- Raise the platform until approximately a height of 7 feet (2 meters) is reached and attempt to drive forward or reverse.
Result: Aerial platform should move slower than when it was in stowed position.

2.5 Winching and Towing Procedures

This section provides the operator with the Winching and Towing procedure, which includes instructions on how to manually release the brakes.



WARNING

Ensure platform is fully lowered before winching or towing. Sudden motion could cause the aerial platform to become unstable. Death or serious injury could result.



WARNING

In emergency situations where aerial platform functions are not available and lowering is impeded by an obstacle, utmost care must be taken to move aerial platform far enough to clear the obstacle. In such cases, operation must be extremely smooth with no sudden movements and must not exceed a speed of 2"/sec (50 mm/sec).



WARNING

When pushing, winching or towing, do not exceed 2 mph (3.2 km/h).



WARNING

Do not push, winch or tow aerial platform onto a slope, or brake the towing vehicle rapidly. Do not pull aerial platform down an incline towards a winch.

2.5-1 To Release Free-wheeling Valve

1. Ensure aerial platform is on level ground. Chock or block the wheels to keep aerial platform from rolling.

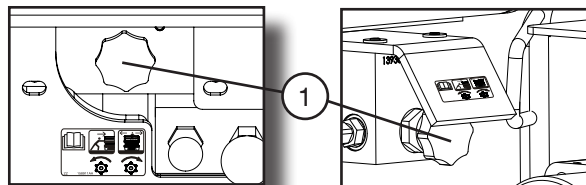

Figure 2-7. Free-wheeling Valve

2. **Free-wheeling Valve** - Turning valve knob counterclockwise (item 1) to a fully opened position allows fluid to flow through the wheel motors, thus providing "free-wheeling."



WARNING

The free-wheeling valve must be closed tightly (clockwise) for normal operation.

2.5-2 To Release Brakes Manually

Releasing the brakes manually depends on the brake system that is provided on the aerial platform.



WARNING

Do not manually disengage brakes if the aerial platform is on a slope.

2.5-2a Pin Brakes System

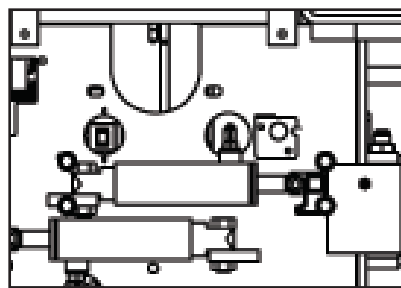

Figure 2-8. Brakes



WARNING

Brakes must be manually disengaged for pushing, winching or towing.

1. Ensure aerial platform is on level ground. Chock or block wheels to keep aerial platform from rolling.
2. Turn main power disconnect switch to “○” off position.
3. **For Left-Side Brake:** Using a 3/4” (19 mm) wrench, rotate the block on the brake pin 90° clockwise. The brake pin should be clear of the brake disc.
4. **For Right-Side Brake:** Using a 3/4” (19 mm) wrench, rotate the block on the brake pin 90° counterclockwise. The brake pin should be clear of the brake disc.
5. Remove wheel chocks or blocks, then push, winch or tow aerial platform to desired location.

**WARNING**

Brakes must be reengaged immediately after reaching the desired location.

6. Position aerial platform on a firm and level surface.
7. Chock or block wheels to prevent aerial platform from rolling.
8. Reengage brakes by doing the following steps.
9. **For Left-Side Brake:** Using a 3/4” (19 mm) wrench, rotate the block on the brake pin 90° counterclockwise.
10. **For Right-Side Brake:** Using a 3/4” (19 mm) wrench, rotate the block on the brake pin 90° clockwise.
11. Close the free-wheeling valve.

2.5-2b Disc Brakes System

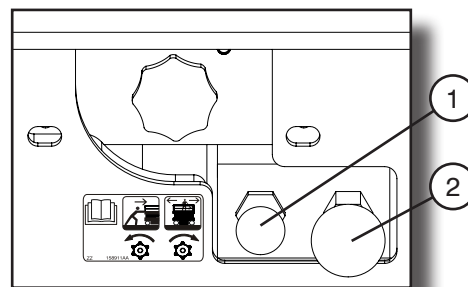

Figure 2-9. Brakes

**WARNING**

Brakes must be manually disengaged for pushing, winching or towing.

1. Ensure aerial platform is on level ground. Chock or block wheels to keep aerial platform from rolling.
2. Turn main power disconnect switch to “○” off position.
3. Locate the brake manifold at the rear of the base.
4. Push in brake auto reset valve plunger (item 1).
5. Grasp brake hand pump (item 2) and rapidly depress until firm resistance is felt. The brakes are now released.
6. Remove wheel chocks or blocks, then push, winch or tow aerial platform to desired location.

**WARNING**

Brakes must be reengaged immediately after reaching the desired location.

7. Position aerial platform on a firm and level surface.
8. Chock or block wheels to prevent aerial platform from rolling.
9. Reengage the brake by pulling out the brake auto reset valve plunger.
10. Close the free-wheeling valve.

2.6 Emergency Lowering Procedure

This section guides the operator on how to use the emergency lowering system. This system allows platform lowering in the event of an emergency or an electrical system failure.



WARNING

Keep clear of scissors mechanism when using emergency lowering valve.

1. Remove any obstructions from a lowering platform.
2. Extension platform(s) may need to be retracted or aerial platform may need to be moved to clear obstruction. Refer to [Section 2.5](#) for winching and towing procedures.

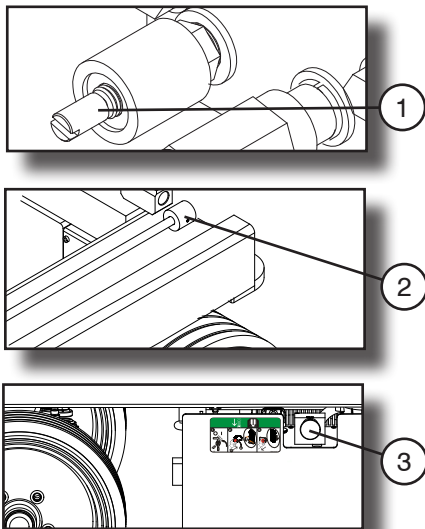

Figure 2-10. Emergency Lowering System

3. Turn main power disconnect switch to “○” off position.
4. Locate the holding valve manual override knob (item 1) at the base of each lift cylinder. Depress and turn counterclockwise. If necessary, use emergency lowering access rod (item 2) that is located on aerial platform base.
5. On hydraulic/electric tray, pull out and hold emergency lowering valve (item 3) to lower platform.
6. To restore normal operation, depress and turn holding valve manual override knobs clockwise.

3.0 Operation

This section provides the necessary information needed to operate the aerial platform. It is important that the user reads and understands this manual before operating the aerial platform.

3.1 General

In order for this aerial platform to be in good working condition, it is important that the operator meets the necessary qualifications and follow the maintenance and inspection schedule referred to in this manual.

3.1-1 Operator Qualifications

- Only trained and authorized personnel shall be permitted to operate an aerial platform.
- Safe use of this aerial platform requires the operator to understand the limitations and warnings, operating procedures and operator's responsibility for maintenance. Accordingly, the operator must understand and be familiar with this operating manual, its warnings and instructions, and all warnings and instructions on the aerial platform.
- The operator must be familiar with employer's work rules and related government regulations and be able to demonstrate the ability to understand and operate this make and model of aerial platform in the presence of a qualified person.

3.1-2 Operator's Responsibility for Maintenance



WARNING

Maintenance must be performed by trained and competent personnel who are familiar with mechanical procedures.

Death or serious injury could result from the use of an aerial platform that is not properly maintained or kept in good working condition.

- The operator must be sure that the aerial platform has been properly maintained and inspected before using it.
- The operator must perform all the daily inspections and function tests found in [Table 4.6](#), even if the operator is not directly responsible for the maintenance of this aerial platform.

3.1-3 Maintenance and Inspection Schedule

- The inspection points covered in [Table 4.6](#) indicate the areas of the aerial platform to be maintained or inspected and at what intervals the maintenance and inspections are to be performed.
- The actual operating environment of the aerial platform may affect the maintenance schedule.



WARNING

Use original or manufacturer-approved parts and components for the aerial platform.

3.1-4 Owner's Inspections

It is the responsibility of the owner to arrange daily, quarterly (or 150 hours) and annual inspections of the aerial platform. Refer to [Table 4.6](#) for recommended maintenance and inspection areas and intervals. A record of annual inspection is kept on a label located on the scissor assembly. Refer to [Table 4.2](#) in this manual.

3.2 Major Components

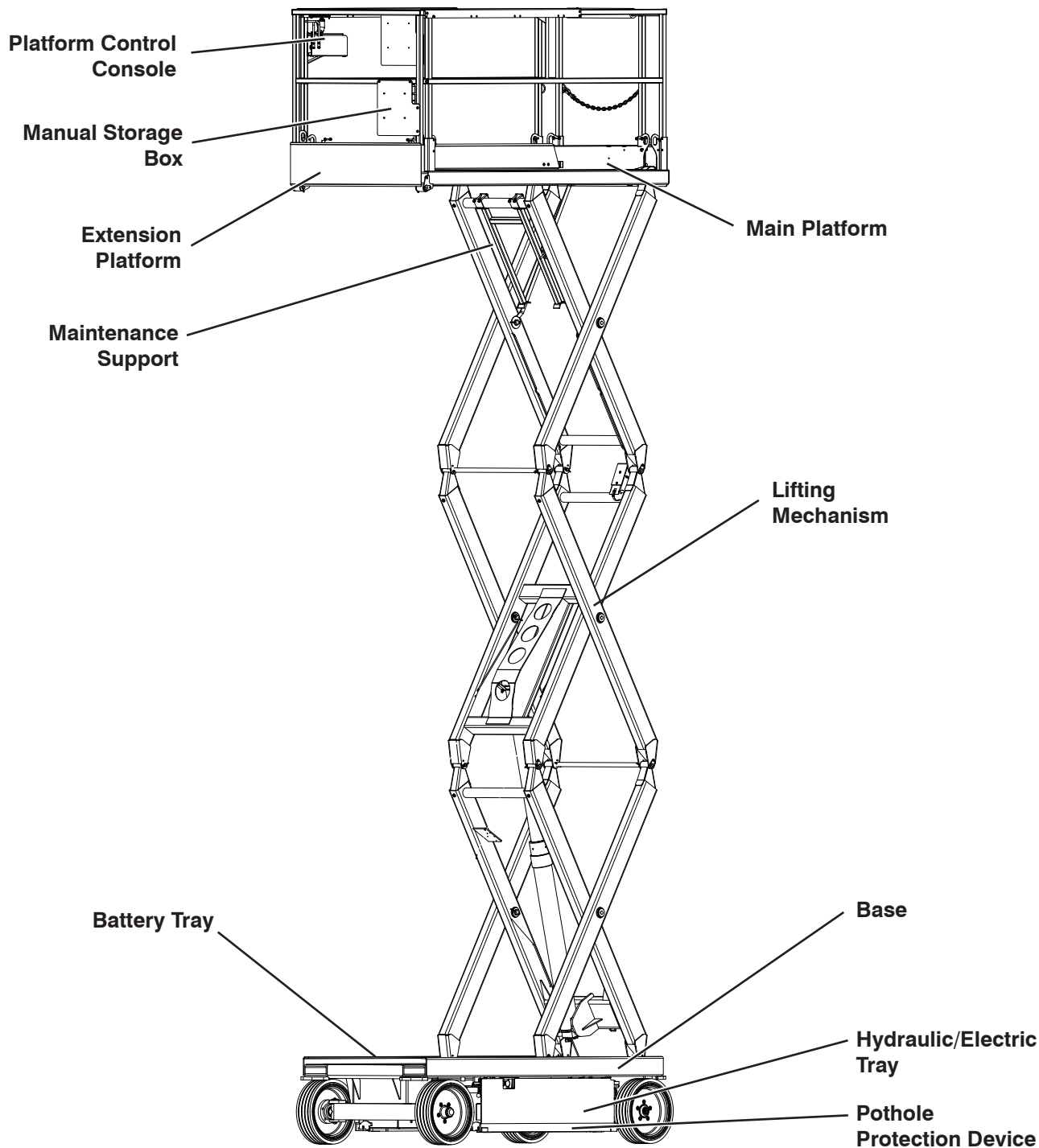

SKYJACK SJIII Series Aerial Platform

3.3 Major Assemblies

The aerial platform consists of three major assemblies: base, lifting mechanism and platform.

3.3-1 Base

The base is a rigid, one-piece weldment which supports two swing out trays.

SJIII 3215 & 3219:

One tray contains the hydraulic and electrical components. The other tray contains four (4) 6 volt batteries. The charger is located at the rear of the aerial platform. The front axle has two hydraulic motor-driven wheels, steerable by a hydraulic cylinder. The rear axle is fixed and has non-driven, spring-applied, hydraulically released brake.

SJIII 3220, 3226, 4620, 4626 & 4632:

One tray contains the hydraulic and electrical components. The other tray contains battery charger and four (4) 6 volt batteries. The front axle has two non-driven wheels, steerable by a hydraulic cylinder. The rear axle has two hydraulic motor-driven wheels with spring-applied, hydraulically released brakes.

3.3-2 Lifting Mechanism

The lifting mechanism is constructed of formed steel or tube sections making up a scissor-type assembly. The scissor assembly is raised and lowered by single-acting hydraulic lift cylinders with holding valves. A pump, driven by an electric motor, provides hydraulic power to the lift cylinders.

3.3-3 Platform

The platform is constructed of a tubular support frame, a skid-resistant "diamond plate" deck surface and 39" hinged guardrails with 6" toe boards and mid-rails. The platform can be entered from the rear through a spring-returned gate with latch. The platform is also equipped with a manual extension platform. An AC outlet is also located on the platform.

3.4 Serial Number Nameplate

The serial number nameplate, located at the rear of the aerial platform, lists the following:

- Model number
- Serial number
- Aerial platform weight
- Maximum drivable height
- Maximum capacities
- Maximum number of persons permissible on the platform
- Voltage
- System pressure
- Lift pressure
- Maximum platform height
- Maximum wheel load
- Date manufactured

3.5 Component Identification

The following descriptions are for identification, explanation and locating purposes only.

3.5-1 Electrical Panel

This panel is located in the hydraulic/electric tray. It contains the following controls:

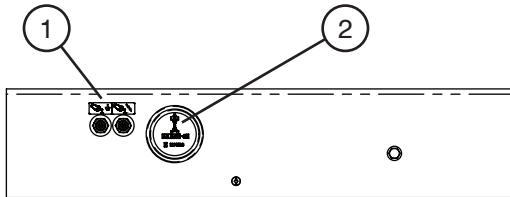

Figure 3-1. Electrical Panel

1. **Circuit Breaker Resets** - In the event of power overload or positive circuit grounding, the circuit breaker pops out. Push the breaker back in to reset.
2. **Hourmeter** - This gauge records accumulated operating time of the aerial platform.

3.5-2 Battery Charger

The charger is located at the rear of the base or inside the battery tray. Refer to [Section 3.13a-2/ Section 3.13b-2](#) for battery charging operation.

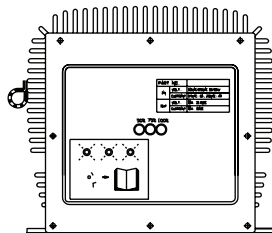

Figure 3-2a. Battery Charger

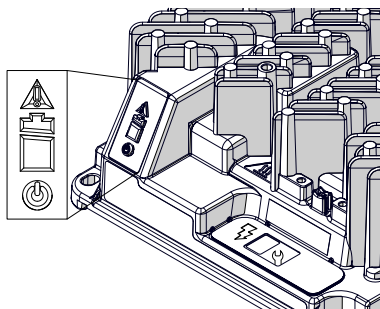

Figure 3-2b. Battery Charger

3.5-3 AC Outlet on Platform

This outlet is a source of AC power on the platform.



WARNING

For EE rated aerial platform, do not use AC power in hazardous locations.

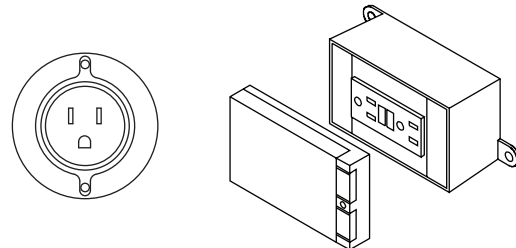

Figure 3-3. AC Outlet on Platform

3.5-4 Pothole Protection Device

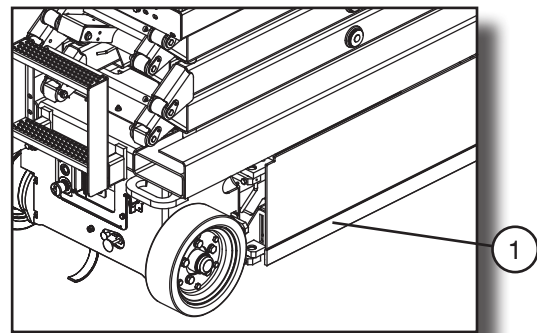

Figure 3-4. Pothole Protection Device

1. **Pothole Protection Device** - This device consists of a set of mechanically actuated steel weldments located under the hydraulic/electric tray and battery tray. These weldments will automatically rotate for reduced ground clearance when elevating the aerial platform. If the pothole protection device has not fully lowered, the drive function will be disabled.



WARNING

Crushing Hazard - Personnel on ground must stay clear of pothole protection device.



WARNING

Do not drive elevated in areas where electrical cords or debris are in the path of travel.

Maintenance of the Pothole Protection Device

As with all safety devices, periodic inspection and maintenance is required to ensure the proper operation of the pothole protection device. This mechanism is designed to reduce ground clearance and assist in the stability of an elevated aerial platform in the event the aerial platform encounters a “drop-off” or “pothole.” The nature of this safety feature relies on maintaining a consistent ground clearance, therefore, if the aerial platform ever does come to rest on the pothole device, the platform should be immediately lowered and “locked out” to prevent further use until a complete inspection of the mechanism is performed by a qualified technician.

3.5-5 Maintenance Support

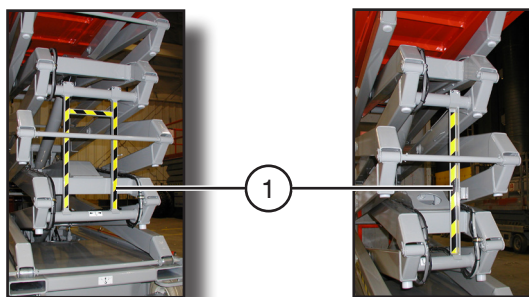

Figure 3-5. Maintenance Support

1. **Maintenance Support** - The maintenance support is a safety mechanism designed to support the scissor assembly. When properly positioned it can support the scissor assembly and empty platform. The maintenance support must be used when inspection and/or maintenance is to be performed within the lifting mechanism. Refer to [Section 3.12](#) for procedure on how use and store the maintenance support.



WARNING

The maintenance support must be used when inspection and/or maintenance or repairs are to be performed within the lifting mechanism. Failure to use this safety mechanism could result in death or serious injury.



WARNING

Do not reach through the scissor assembly when the platform is raised without the maintenance support properly positioned. Failure to avoid this hazard could result in death or serious injury.

3.5-6 Manual Storage Box

This weather-resistant box is mounted on the platform railings. It contains operating manual, ANSI manual of responsibility and ANSI/CSA certificate. The operating manual for this make and model of aerial platform must remain with the aerial platform and should be stored in this box.

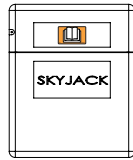

3.5-7 Folding Guardrail System

This system, when folded down, reduces the height of the retracted aerial platform for transporting and traveling through doorways only. Refer to [Section 3.9](#) for guardrail folding procedure.

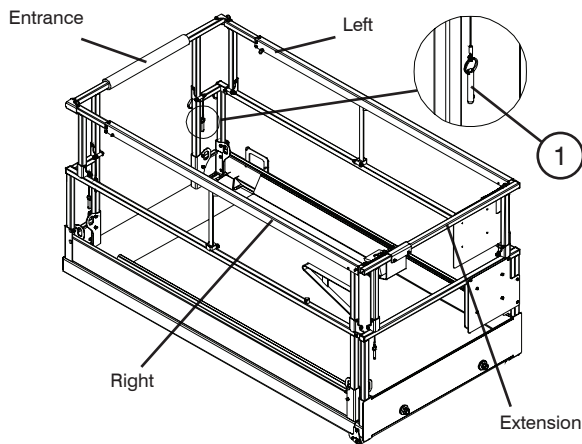

Figure 3-6. Folding Guardrail System

- Guardrail Locking Pin with Lanyard** - This pin is used to lock the guardrail in place.



WARNING

The scissor assembly must be fully lowered before raising or lowering the guardrails.

3.5-8 Fall Protection Anchorage

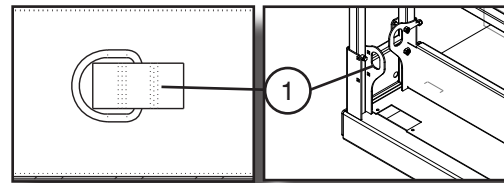

Figure 3-7. Fall Protection Anchorage

- Fall Protection Anchorage** - Use this as an attachment point for a fall restraint system. Do not attach anchorage connectors to any other point on the platform. Do not use this to lift, anchor, secure or support the platform or any other apparatus or material.



WARNING

The fall protection anchorage is to be used for restraint, within the limits of the platform, only.

3.6 Component Identification (Optional Equipment/Attachments)

This section describes the components that are optional to aerial platforms.

3.6-1 Powered Extension Control Console (If Equipped)

This control console is mounted on one of the extension platform guardrails. It contains the following controls:

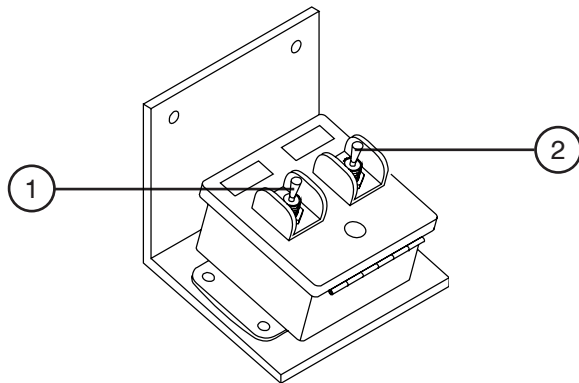



Figure 3-8. Powered Extension Control Console

1. **Enable Switch** - This switch, when activated and held, allows the extension platform extend/retract switch functions to operate.
2. **Extend/Retract Switch** - This switch, when activated, “” extends or “” retracts the powered extension platform. Refer to [Section 3.8-9](#) on how to extend/retract the powered extension platform.

3.6-2 1500W AC Inverter (If Equipped)

The inverter is located on the base of the aerial platform. It has the following controls:

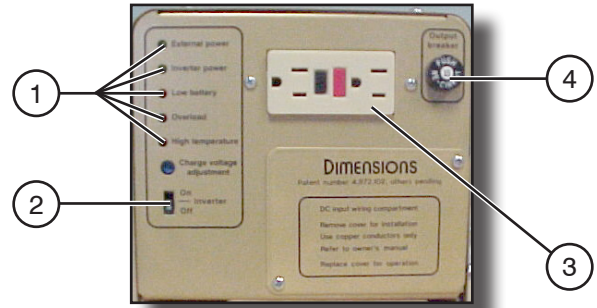

Figure 3-9. 1500W AC Inverter

NOTE

The inverter operation is automatic. These controls do not need to be manipulated for normal operation.

1. **Status LEDs** - These LEDs indicate the operating or fault status of the inverter.
2. **On/Off Switch** - This diagnostic slide switch activates or terminates inverter operation. It should remain in on position.
3. **GFCI Outlet** - During inverter operation, this outlet provides AC power.
4. **15 Amp Circuit Breaker** - In the event of a power overload or circuit grounding, the circuit breaker pops out. Press the breaker back in to reset.

3.6-3 Motion Alarm (If Equipped)

The alarm produces an audible sound when any control function is selected. On aerial platforms with certain options, a flashing amber light will accompany this alarm.

3.6-4 Using Optional Control Box with Long Cable from Ground:



WARNING

Skyjack scissor lifts are to be operated from the operator's position on the platform with the control box secured on the mounting bracket at the front right portion of the platform. Operation of the unit from the ground is permissible only when maintaining the lift or, in limited circumstances, when an obstruction precludes the safe operation of the lift from the operator's position on the platform. Operation from the ground is to be performed as set forth in the Operating Manual.

1. Before operating this aerial platform, perform the following steps:
 - Visual and daily maintenance inspections (see [Section 2.3](#))
 - Function tests (see [Section 2.4](#)).
2. Ensure the platform is in the fully-stowed (lowered) position.



WARNING

To protect against unintended movement of the aerial platform, push in the emergency stop button after you have arrived at your desired location.

3. Disconnect and remove platform control console from the mounting bracket at the front right portion of the platform.



WARNING

Ensure that you maintain three points of contact when using the ladder to mount/dismount platform.

Operation from the Ground:

4. The control box with long cable may be connected to the lower base control connector or to the platform control connector.

NOTE

For some models, the connection is located beneath an access panel which requires that the scissor assembly be raised to access it.

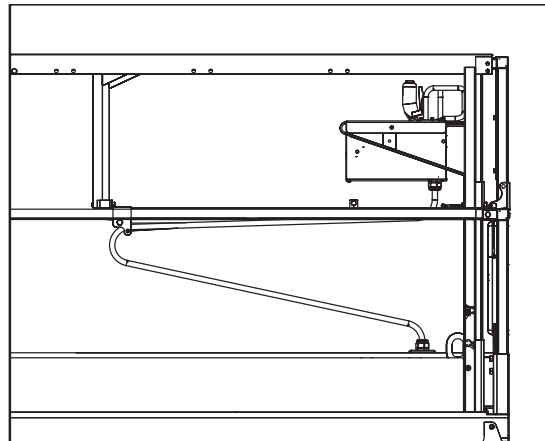

Figure 3-10. Control Box with Long Cable

**WARNING**

- **Ensure the operator and control box console are properly oriented in the direction the aerial platform is facing (see Figure 3-11).**
 - **Do not drive the aerial platform toward yourself.**
 - **Avoid crushing hazards; stand clear from the aerial platform and out of the direction of travel.**
 - **During loading/unloading operations using a ramp, ensure all personnel (including operator) stand away from the direction of any potential fall-over of the aerial platform from the ramp or movement of the aerial platform down the ramp.**
 - **Ensure that the control box with long cable does not become entangled with the aerial platform or any surrounding objects.**
5. Perform a thorough jobsite inspection prior to operating the aerial platform to identify potential hazards in your work area.
 6. Cordon-off the pathway in which you intend to travel.
 7. Ensure there are no personnel in the intended path of travel.
 8. Notify those around the pathway that you will be moving the aerial platform.
 9. Use a spotter to guide movement where necessary. Ensure the spotter remains at a safe distance.
 10. Once safely reached your destination, push in emergency stop button and turn main power disconnect switch to “O” off position.

**WARNING**

Ensure that you maintain three points of contact when using the ladder to mount/dismount platform.

11. Mount the platform control console to mounting bracket at the front right portion of the platform.

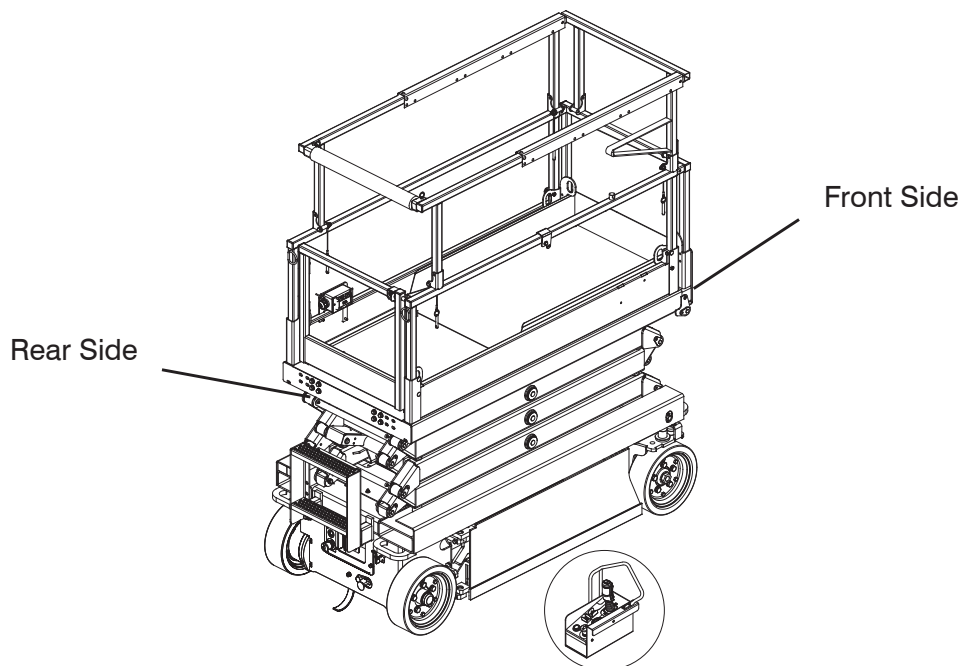

Figure 3-11. Control Box with Long Cable Outside Platform

3.7 Operator's Responsibility

It is the responsibility of the operator, prior to each work shift, to perform the following:

1. Visual and Daily Maintenance Inspections

- are designed to discover any damage of components before the aerial platform is put into service.
- are done before the operator performs the function tests.



WARNING

Failure to locate and repair damage, and discover loose or missing parts may result in an unsafe operating condition.

2. Function Tests

- are designed to discover any malfunctions before the aerial platform is put into service.

IMPORTANT

The operator must understand and follow the step-by-step instructions to test all aerial platform functions.

The operator should make a copy of the Operator's Checklist (see Table 4.7) and fill out the visual and daily maintenance inspections and the function tests sections while performing the items outlined in Section 2.3 and Section 2.4.

IMPORTANT

If aerial platform is damaged or any unauthorized variation from factory-delivered condition is discovered, aerial platform must be tagged and removed from service.

Repairs to the aerial platform may only be made by a qualified service technician. After repairs are completed, the operator must perform visual and daily maintenance inspections & function tests again.

Scheduled maintenance inspections shall only be performed by qualified service technician (see Table 4.6).

3.8 Start Operation

Carefully read and completely understand the operating manual and all warnings and instruction labels (refer to [Section 5 - Labels](#)) on the aerial platform.



WARNING

Do not operate this aerial platform without proper authorization and training. Failure to avoid this hazard could result in death or serious injury.

Before operating this aerial platform, perform the following steps:

1. Visual and daily maintenance inspections (see [Section 2.3](#))
2. Function tests (see [Section 2.4](#))
3. Job site inspection

It is the responsibility of the operator to perform a job site inspection and avoid the following hazardous situations:

- holes or drop-offs
- ditches or soft fills
- floor obstructions, bumps or debris
- overhead obstructions
- electrical cords, hoses and high voltage conductors
- hazardous locations (see NFPA 505)
- inadequate surface support to withstand all load forces imposed by the aerial platform
- wind and weather conditions
- the presence of unauthorized personnel
- other possible unsafe conditions



WARNING

An operator should not use any aerial platform that:

- **does not appear to be working properly.**
- **has been damaged or appears to have worn or missing parts.**
- **has alterations or modifications not approved by the manufacturer.**
- **has safety devices which have been altered or disabled.**



Failure to avoid these hazards could result in death or serious injury.

3.8-1 To Activate Base Control Console



WARNING

Ensure that you maintain three points of contact when using the ladder to mount/dismount platform.

1. Use the ladder of aerial platform to access platform.
2. Close the gate.
3. On platform control console, pull out “” emergency stop button.
4. Use the ladder to dismount from platform.
5. Turn main power disconnect switch to “” on position.
6. On base control console, pull out “” emergency stop button.

3.8-2 To Raise or Lower Platform Using Base Control Console





WARNING

Be aware of overhead obstructions or other possible hazards around the aerial platform when lifting.





WARNING

Do not lower the platform unless the area is clear of personnel and obstructions.

1. Activate base control console (refer to [Section 3.8-1](#)).
2. Select and hold off/platform/base key switch to “” base position.
3. Select and hold lower/neutral/raise switch to either “” raise or “” lower position. Release switch to stop.

3.8-3 To Activate Platform Control Console

1. Turn main power disconnect switch to “I” on position.
2. On base control console, pull out “” emergency stop button.
3. Select off/platform/base key switch to “” platform position.



WARNING

Ensure that you maintain three points of contact when using the ladder to mount/dismount platform.

4. Use the ladder of aerial platform to access platform.
5. Close the gate.
6. On platform control console, pull out “” emergency stop button.

3.8-4 To Raise or Lower Platform Using Platform Control Console





WARNING

Be aware of overhead obstructions or other possible hazards around the aerial platform when lifting.



WARNING

Do not lower the platform unless the area below is clear of personnel and obstructions.

1. Activate platform control console (refer to [Section 3.8-3](#)).
2. Select lift/off/drive switch to “” lift position.
3. Activate and hold “” enable trigger switch.
4. Move controller handle forward or backward until desired height is reached.

NOTE

Lowering is not proportional.

5. Return controller to neutral center position to stop. Release “” enable trigger switch.



WARNING

To protect against unintended movement of the aerial platform, push in the emergency stop button after you have arrived at your desired location or elevation.

NOTE

If the tilt alarm sounds and the platform does not, or only partially raises, immediately lower the platform completely and ensure that the aerial platform is on a firm level surface.





3.8-5 To Drive Forward or Backward

**WARNING**

Be aware of blind spots when operating the aerial platform.

**WARNING**



Ensure that there are no personnel or obstructions in the path of travel, including blind spots.

1. Activate platform control console (refer to [Section 3.8-3](#)).
2. Select lift/off/drive switch to “” drive position.
3. Activate and hold “” enable trigger switch.
4. Move controller handle “” forward/up or “” backward/down to desired speed and direction of aerial platform travel.
5. Return controller to neutral center position to stop.
Release “” enable trigger switch.

**WARNING**

To protect against unintended movement of the aerial platform, push in the emergency stop button after you have arrived at your desired location or elevation.

3.8-6 To Steer

1. Activate platform control console (refer to [Section 3.8-3](#)).
2. Select lift/off/drive switch to “” drive position.
3. Activate and hold “” enable trigger switch.
4. Press “” rocker switch on top of controller handle in either direction to steer.

NOTE

Steering is not proportional. Driving and steering may be active at the same time.

3.8-7 To Select Level Drive or Inclined Drive Mode (If Equipped)

1. Level Drive Mode

Select level drive mode when traveling on flat surface.

To activate level drive mode, select inclined drive/level drive switch to “” level drive (high speed/low torque) position.



WARNING
Aerial platform must be in fully retracted position when operated on any grade. Driving while elevated on any grade may result in death or serious injury.

2. Inclined Drive Mode

Select inclined drive mode when climbing grades or when loading or unloading the aerial platform.

To activate inclined drive mode, select inclined drive/level drive switch to “” inclined drive (low speed/high torque) position.



WARNING
To protect against unintended movement of the aerial platform, push in emergency stop button after you have arrived at your desired location or elevation.

3.8-8 To Extend/Retract Manual Extension Platform



DANGER
Crushing Hazard - Extension platform must not be retracted manually from the ground.

1. To extend/retract manual extension platform, remove retaining locking pins and push/pull extension platform using the push bar or sliding handrails to one of four or five desired locking positions.
2. Upon extension or retraction, reinsert locking pins. Insert pin on one side of aerial platform in front of upright bar and the pin on the other side of aerial platform behind the upright bar to prevent accidental movement, in either direction, of manual extension platform during travel or transport. Refer to [Figure 3-12](#) for a configuration example.

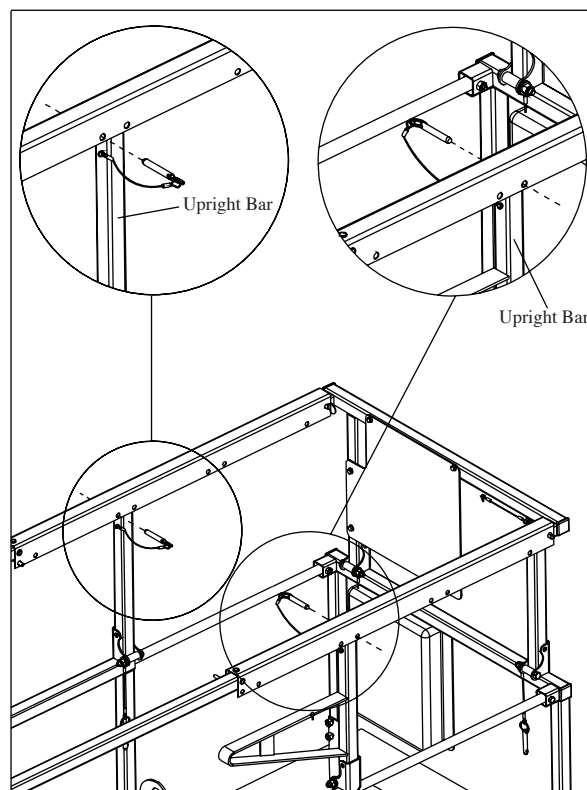







Figure 3-12. Variable Position Manual Extension Platform

3.8-9 To Extend/Retract Powered Extension Platform (If Equipped)



1. To extend/retract powered extension platform, ensure “” emergency stop button is pulled out.
2. Select lift/off/drive switch to “” lift position.
3. On powered extension control console, press and hold “” enable switch, then push extend/retract switch to “” extend position. Release switch to stop.
4. To retract extension platform, press and hold “” enable switch, then push extend/retract switch to “” retract position. Release switch to stop.



WARNING

To protect against unintended movement of the aerial platform, push in emergency stop button after you have arrived at your desired location or elevation.

3.8-10 Electrical Inverter (If Equipped)

1. Turn main power disconnect switch to “” on position.
2. Make sure on/off switch of the inverter is “” on position.
3. Inverter state is indicated by the LEDs on the face of the inverter. A glowing green LED indicates normal operation. If a fault occurs, the status LEDs will indicate the area responsible.



CAUTION

The main power disconnect switch must be turned off at the end of the shift or the batteries will drain.



3.8-11 Shutdown Procedure

1. Completely lower the platform.
2. On platform control console, push in “” emergency stop button.



WARNING

Ensure that you maintain three points of contact when using the ladder to mount/dismount platform.

3. Use the ladder to dismount from platform.
4. On base control console, select off/platform/base key switch to “” off position and remove the key.
5. Turn main power disconnect switch to “” off position.

3.9 Guardrail Folding Procedure

When folded down, the folding guardrail system reduces the height of the retracted aerial platform for transporting only.



WARNING

Any lowered guardrail will create a fall hazard. Remain away from the side of the platform while raising or lowering the guardrails to avoid falling.

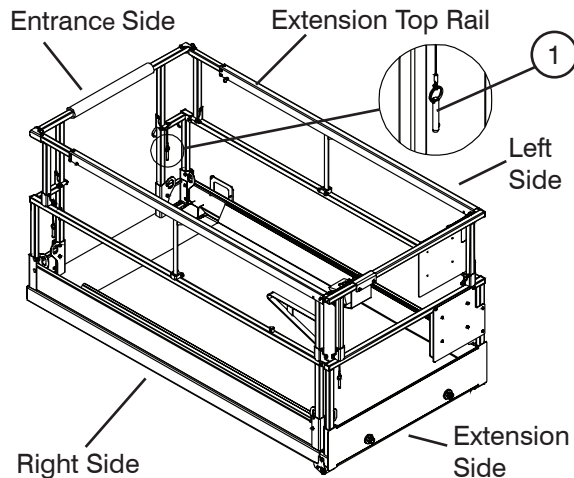

Figure 3-13a. Folding Guardrail System

1. **Guardrail Locking Pin with Lanyard** - This pin is used to lock the guardrail in place.



WARNING

The scissor assembly must be fully lowered before raising or lowering the guardrails.



WARNING

Before operating this aerial platform, check the guardrail system for loose or missing locking pins. The guardrail system must be upright and all pins must be locked in place. Death or serious injury could result if the guardrail system is not upright or properly locked.

To fold the guardrail system down:

1. Ensure aerial platform is on level ground.
2. Ensure extension platform is fully retracted.
3. Ensure Emergency Stop button is depressed.
4. Turn main power disconnect switch to “○” off position.



WARNING

Ensure that you maintain three points of contact when using the ladder to mount/dismount platform.

5. Use the ladder of aerial platform to access platform.
6. Close the gate.
7. Remove the platform control console and lay it down on the platform.



WARNING

Any lowered guardrail will create a fall hazard. Use caution when exiting or entering the platform when the guardrails are lowered.

8. Remove left and right side pins A and B (if equipped). (Refer to Figure 3-13b):

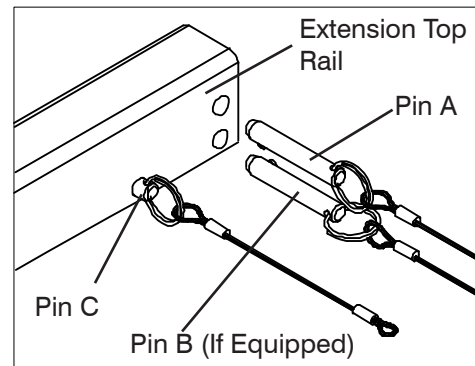

Figure 3-13b. Extension Top Rail Pins



WARNING

Ensure pin C is in place and secured to the Extension Top Rail.

- Remove remaining pins from all sides and carefully fold all guardrails in the following order:

SJIII 32xx

- Entrance**
Use tie wrap to secure entrance bar to left guardrail.
- Right Side**
- Left Side**
- Extension**
Lock extension guardrail into place on the mounting post. Ensure that the detent ball of the pin is all the way through. (Refer to Figure 3-13c)

SJIII 46xx

- Right Side**
- Left Side**
- Entrance**
- Extension**
Lock extension guardrail into place on the mounting post. Ensure that the detent ball of the pin is all the way through. (Refer to Figure 3-13c)

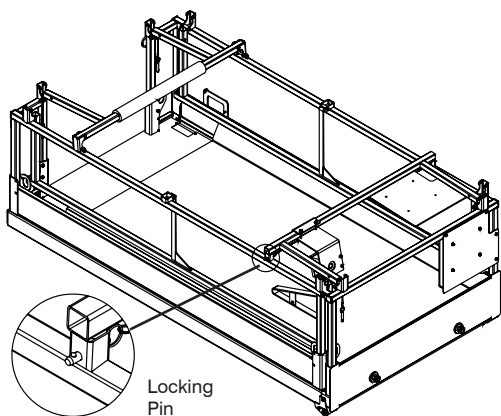

Figure 3-13c. All Guardrails Folded Down

**WARNING**

Ensure that you maintain three points of contact when using the ladder to mount/dismount platform.

To raise the guardrail system up:

- Ensure aerial platform is on level ground.
- Ensure extension platform is fully retracted.
- Ensure Emergency Stop button is depressed.
- Turn main power disconnect switch to “○” off position.

**WARNING**

Any lowered guardrail will create a fall hazard. Use caution when exiting or entering the platform when the guardrails are lowered.

**WARNING**

The scissor assembly must be fully lowered before raising or lowering the guardrails.

**WARNING**

Ensure that you maintain three points of contact when using the ladder to mount/dismount platform.

- Use the ladder of aerial platform to access platform.
- Remove locking pin from mounting post and carefully raise extension guardrail up and lock into place with locking pins ensuring that the detent ball of each pin is all the way through (Refer to Figure 3-13c).
- Carefully raise each guardrail up and lock into place with locking pins ensuring that the detent ball of each pin is all the way through (Refer to Figure 3-13a).
- Mount the platform control console at the front right of the platform. Lock it in place.

**WARNING**

Before operating this aerial platform, check the guardrail system for loose or missing locking pins. The guardrail system must be upright and all pins must be locked in place. Death or serious injury could result if the guardrail system is not upright or properly locked.

3.10 Loading/Unloading

Know and heed all national, state or territorial/provincial and local rules which apply to your loading/unloading of aerial platforms.

Only qualified personnel shall operate the aerial platform during loading/unloading.

Be sure vehicle capacity and loading equipment hoists, chains, straps, etc., are sufficient to withstand maximum aerial platform weight.

The transport vehicle must be parked on a level surface and must be secured to prevent rolling while aerial platform is being loaded/unloaded.

3.10-1 Lifting



WARNING

Only qualified rigger shall operate machinery during lifting.

When it is necessary to lift the Skyjack aerial platform the following conditions must be met:

- The platform must be fully lowered.
- The main power disconnect switch must be in “○” off position.
- The hydraulic/electric and battery trays must be closed and securely latched.
- The extension platform must be retracted and secured.
- The platform control console must be secured to the railings or removed.
- The platform must be cleared of all personnel, tools and materials.
- The lifting/rigging must be attached to all four lifting points as illustrated in [Figure 3-14](#).

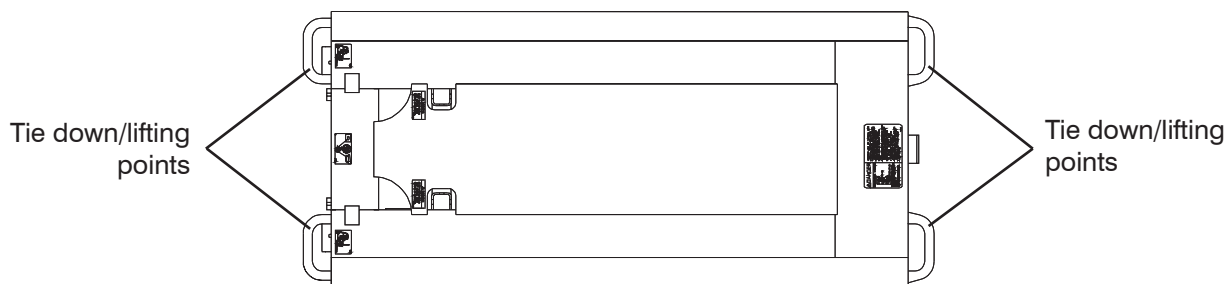

Figure 3-14. Tie Downs/Lifting Points

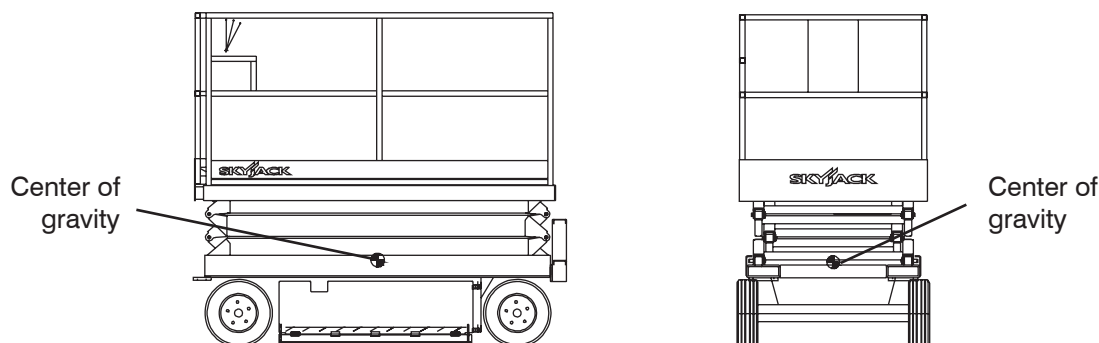

Figure 3-15. Center of Gravity

NOTE

The mass of the aerial platform is as per [Table 4.3a.](#) or [Table 4.3b.](#) The center of gravity is approximately located in the middle of the aerial platform, front to back and side to side, as illustrated in [Figure 3-15.](#) Vertically, the center of gravity is approximately just above the base chassis.

NOTE

The aerial platform can be lifted with a forklift from the sides but Skyjack does not recommend this use. Lift with forks in designated pockets as illustrated in [Figure 3-16.](#)

3.10-2 Driving

Before driving the aerial platform:

- Ramp or dock capacity should be sufficient to withstand maximum aerial platform weight.
- Ramp should be equipped with side guards to prevent inadvertent fall from the ramp.
- Incline should not exceed aerial platform gradeability (refer to [Table 4.3a](#) or [Table 4.3b](#)).
- Aerial platform brakes should be checked for proper operation.
- Aerial platform speed should be on high torque setting (if equipped).

**WARNING**

When transporting, the aerial platform must be secured to the truck or trailer deck. Tie downs are available as illustrated in [Figure 3-14.](#)

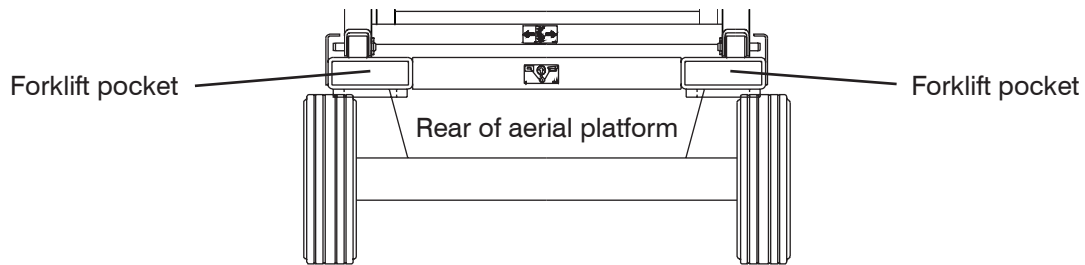

Figure 3-16. Forklift Pockets

3.11 Moving the Aerial Platform Through a Doorway



WARNING

This procedure is suitable for level ground only.

1. Confirm that the height/width of the doorway is sufficient to allow the aerial platform to pass through.

NOTE

If it is necessary to fold the guardrails, refer to [Section 3.9](#) for guardrail folding procedure.

2. Perform a thorough job site inspection prior to operating the aerial platform to identify potential hazards in your work area.
3. Cordon-off the pathway which you intend to travel.
4. Position the aerial platform to allow all future motion, including through the doorway, to be in a forward direction.
5. Turn main power disconnect switch to “○” off position.
6. Use the ladder of aerial platform to access platform.



WARNING



Ensure that you maintain three points of contact when using the ladder to mount/dismount platform.

7. Close the gate. On platform control console, push in “●” emergency stop button.
8. Disconnect and remove platform control console from the platform.
9. Fold the guardrails if necessary. Refer to [Section 3.9](#) for guardrail folding procedure.
10. Use the ladder to dismount from platform.

11. Connect platform control console to the connection at the rear of the base.

NOTE



For some models, the connection is located beneath an access panel which requires that the scissor assembly be raised to access it.

12. Ensure there are no personnel in the intended path of travel.
13. Notify those around the pathway that you will be moving the aerial platform.
14. Use a spotter to guide movement. Ensure the spotter remains at a safe distance.
15. Ensure that platform control console is properly oriented in the direction the aerial platform is facing.
16. Turn main power disconnect switch to “|” on position.
17. On base control console, pull out “●” emergency stop button.
18. Select base/off/platform key switch to “” platform position.
19. On platform control console, pull out “●” emergency stop button.
20. Select lift/off/drive switch to “” drive position. Select inclined drive/level drive switch to “” inclined drive (low speed/high torque) position for reduced speed.
21. Using as low a speed as practical and the operator positioned behind the aerial platform, drive forward through doorway.



WARNING

Do not drive the aerial platform toward yourself.

22. Once safely through doorway, push in “” emergency stop button and turn main power disconnect switch to “” off position.
23. Disconnect platform control console and return it to the platform.

**WARNING**

Ensure that you maintain three points of contact when using the ladder to mount/dismount platform.

24. Return guardrails to upright position if folded. Refer to [Section 3.9](#) for guardrail folding procedure.

**WARNING**

Before operating this aerial platform check the guardrail system for loose or missing locking pins. The guardrail system must be upright and all pins must be locked in place.

Death or serious injury could result if the guardrail system is not upright or properly locked.

25. Once the platform control console is securely reconnected and guardrails up, normal operation may continue.

3.12 Maintenance Support Procedure

This section provides the operator with procedure regarding deployment and storage of maintenance support.

The maintenance support is a safety mechanism designed to support the scissor assembly. When properly positioned it can support the scissor assembly and empty platform. The maintenance support must be used when inspection and/or maintenance is to be performed within the lifting mechanism.



WARNING

The maintenance support must be used when inspection and/or maintenance or repairs are to be performed within the lifting mechanism. Failure to use this safety mechanism could result in death or serious injury.

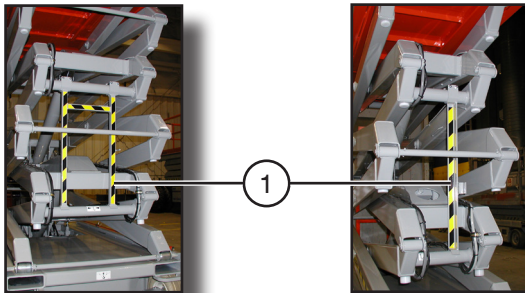

Figure 3-17. Maintenance Support

To Deploy the Maintenance Support

1. Remove all material from platform.
2. Raise platform until there is adequate clearance to swing down maintenance support (item 1).
3. Swing maintenance support down from storage bracket into a vertical position.
4. Remove hands and arms from scissors area.
5. Lower platform until bottom end of maintenance support contacts the labeled cross bar and scissors are supported by maintenance support.
6. Turn main power disconnect switch to “○” off position.

To Store the Maintenance Support

1. Turn main power disconnect switch to “|” on position.
2. Raise platform until there is adequate clearance to swing up the maintenance support.
3. Swing bar fully up into storage bracket.
4. Lower the platform.



WARNING

Do not reach through the scissor assembly when the platform is raised without the maintenance support properly positioned. Failure to avoid this hazard could result in death or serious injury.

3.13a Battery Maintenance

This section provides the operator with procedures on how to service and charge the battery. This also provides charger operation instructions.

3.13a-1 Battery Service Procedure



WARNING

Explosion Hazard - Keep flames and sparks away. Do not smoke near batteries.



WARNING

Battery acid is extremely corrosive - Wear proper eye and facial protection as well as appropriate protective clothing. If contact occurs, immediately flush with cold water and seek medical attention.

1. Turn main power disconnect switch to “○” off position.
2. Check battery case for damage.
3. Check battery fluid level in each battery. If plates are not covered by at least 1/2” (13 mm) of solution, add distilled or demineralized water.
4. Clean battery terminals and cable ends thoroughly with a terminal cleaning tool or wire brush.
5. Make sure all battery connections are tight.
6. Replace any battery that is damaged or incapable of holding a lasting charge.
7. Do not use any batteries other than flooded lead-acid batteries of the proper AH rating.



WARNING

Use original or equivalent to the original parts and components for the aerial platform.

3.13a-2 Battery Charging Operation

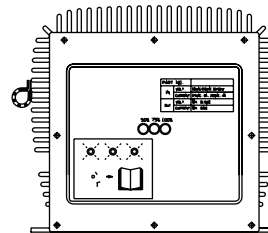

Figure 3-18. Battery Charger



DANGER

Risk of electric shock - Do not immerse the charger in water. Though the charger is highly resistant to water, it is not designed for immersion and an electric shock can occur.

1. Provide adequate ventilation for the batteries and charger. The convection cooled design requires access to cooling air for proper operation. Do not allow blankets or other materials to cover the charger. Although the charger protects itself against overheating, the charger cooling fins should be cleaned if clogged with debris for best performance.



WARNING

There could be a spark during charging. Be careful when using fuels, solvents or other flammables near the charger or batteries.

2. Connect the power supply cord to a properly grounded 100V/50 or 60Hz, 115V/50 or 60Hz, or 230V/50 or 60Hz socket. This charger automatically senses and adjusts to the AC input voltage range.



CAUTION

When changing the input voltage wait until all the LEDs are OFF or wait a minimum of 20 seconds before switching on the new voltage.

- 3. The charging time is affected by numerous factors including battery Amp-Hour capacity, depth of discharge, battery temperature, and battery condition (new, old or defective). Batteries larger than 240 AH can be recharged but will take longer.



WARNING

Do not disconnect the DC output wires near the batteries when the charger is ON. The resulting arcing could cause the batteries to explode. If the charger must be disconnected, first disconnect the AC power supply cord from its outlet, then disconnect the charger DC connections.



WARNING

Risk of an electric shock - Do not touch un-insulated parts of the charger output wires, battery connector, or battery terminals.



WARNING

Visually and manually inspect to verify the DC output wires and terminals are in good working condition before each use.

- 4. The charger will start automatically within four to six seconds. The charger will start even with severely discharged batteries (down to 1V terminal voltage). Once charging starts, the LEDs indicate the charging progress.

Charging State LED

State of charge	1 ST LED	2 ND LED	3 RD LED
0 to 50%	Blinking	Off	Off
50% to 75%	On	Blinking	Off
75% to 100%	On	On	Blinking
100%	On	On	On

60133AA

The charger goes into an equalizing charge mode after the batteries are charged and all 3 LEDs are “ON”. The charger will continue to charge at a low current then shut off automatically when complete. If all 3 LEDs blink together, there is a problem.

Take proper action according to the following instructions:

3 LEDs blink once simultaneously:

Output connection error. Check the battery and charger connection. The output may not be connected to the batteries or the connections to the batteries may have corroded or loosened. The output may be shorted due to improper connection to the batteries or pinched wires. The output may be connected in reverse polarity to the batteries. The charger is not damaged by any of these problems.

3 LEDs blink twice simultaneously:

The charger is indicating that the AC voltage is too low or too high. Check the AC input voltage.

3 LEDs blink three times simultaneously:

Charger is overheated. No action required. When the charger cools, charging will restart automatically. Check and correct for dirt or other debris on charger that may be reducing cooling.

3 LEDs blink four times simultaneously:

Input or output over current. No action required, charger will correct and restart automatically.

100% LED lamp blinks:

Charger 18-hour timer has timed out due to battery problem.

Batteries do not fully charge.

If the batteries are charged overnight, make sure the AC supply is not being switched off at night with other building items. Check battery condition and for dead cells or reduced capacity. Replace charger only if other problems are not found.

The AC line circuit breaker or fuse is blown.

A defective circuit breaker or fuse, an overloaded circuit, or a charger problem can cause this condition. Try connecting the charger to a different AC outlet (on a different circuit) in the building. If the AC supply checks good, the charger should be replaced.

EE-Rated Aerial Platforms**WARNING**

Do not charge batteries in hazardous area! The EE-rating of an aerial platform does not include the charging of batteries.

1. Move the aerial platform to an area designated for battery charging. Refer to NFPA 505 for charging setup. NFPA 505 is a publication of the **National Fire Protection Association, Inc.**, Batterymarch Park, Quincy, MA 02269 (USA).

NOTE

The charging temperature for an EE-rated aerial platform is limited 40°C ambient.

2. Charge batteries. Refer to [Section 3.13-2](#) for battery charging operation. When charge cycle is completed, disconnect charger plug from battery tray.

3.13b Battery Maintenance (If Equipped)

This section provides the operator with procedures on how to service and charge the battery. This also provides the charger operation instructions.

3.13b-1 Servicing the battery

WARNING



Explosion hazard. Keep flames and sparks away. Do not smoke near batteries. Battery acid releases explosive gas while charging. Charge batteries in a well-ventilated area.

WARNING

Battery acid is extremely corrosive – wear proper eye and facial protection as well as appropriate protective clothing. If contact occurs, immediately flush with cold water and seek medical attention.

1. Turn the main power disconnect switch to the off position.
2. Check the battery case for damage.
3. Check the battery fluid level in each battery. If the plates are not covered by at least 13 mm (1/2 in) of solution, add distilled or demineralized water.
4. Make sure all the battery connections are tight.

NOTE

Do not use any batteries other than the flooded lead-acid batteries of the proper Ah rating.

WARNING

Use the original or equivalent to the original parts and components for the MEWP.

3.13b-2 Charging the battery

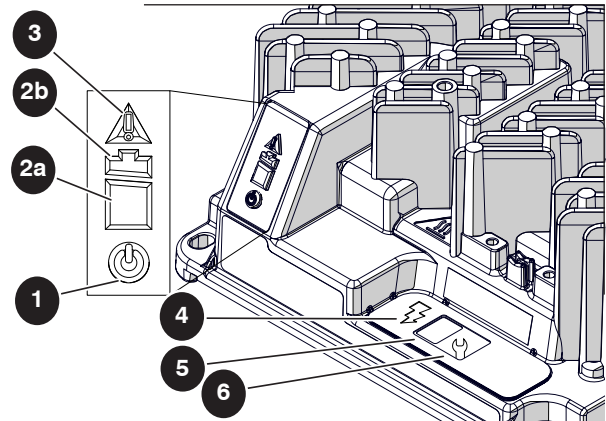

Figure 3-19. Battery Charger

No.	Indicator type	State	Description/action required
1	AC power	Blue	Battery charger is connected to the AC power.
2a	Battery charging <80%	Flashing green	Low charge— continue charging.
		Solid green	High charge— continue charging.
2b	Battery charging >80%	Flashing green	High charge— can discontinue charging.
		Solid green	Charge complete— discontinue charging.
3	Fault/error	Solid red	Charger fault—refer to the service manual.
		Flashing amber	Error encountered—refer to the service manual.
4	Charging output	Solid yellow	Charger output is active.
5	Charge profile/error display	Current algorithm or fault/error code	N/A.
6	Select charge profile	Current charging algorithm	N/A.

⚠ WARNING

Risk of electric shock – do not immerse the charger in water. Though the charger is highly resistant to water, it is not designed for immersion, and an electric shock can occur.

⚠ CAUTION

Hot Surfaces - During charging, the surface of the charger may become hot to the touch, especially in higher ambient temperatures. This is normal. Avoid touching the surface of the charger.

1. Provide adequate ventilation for the batteries and charger.

NOTE

The convection cooled design requires access to cooling air for proper operation. Do not allow blankets or other materials to cover the charger. Although the charger protects itself against overheating, the charger cooling fins should be cleaned if clogged with debris for best performance.

⚠ WARNING

There could be a spark during charging. Be careful when using fuels, solvents or other flammables near the charger or batteries.

2. Connect the power supply cord to a properly grounded socket between 100 to 240 VAC, 50/60 Hz. The charger automatically senses and adjusts to the AC input voltage range.
3. The charging time is affected by numerous factors including the battery Amp-Hour capacity, depth of discharge, battery temperature, and battery condition (new, old, or defective). Batteries larger than 240 AH can be recharged but will take longer.

⚠ WARNING

Do not disconnect the DC output wires near the batteries when the charger is ON. The resulting arcing could cause the batteries to explode. If the charger must be disconnected, first disconnect the AC power supply cord from its outlet, then disconnect the charger DC connections.

⚠ WARNING

Risk of an electric shock – do not touch uninsulated parts of the charger output wires, battery connector, or battery terminals.

⚠ WARNING

Visually and manually inspect to verify the DC output wires and terminals are in good working condition before each use.

4. The charger will start automatically within four to six seconds. The charger will start even with severely discharged batteries (down to 1 V terminal voltage). Once the charging starts, the LEDs indicate the charging progress.
 - **Batteries do not fully charge:** If the batteries are charged overnight, make sure the AC supply is not being switched off at night with other building items. Check the battery condition and for dead cells or reduced capacity. Replace the charger only if other problems are not found.
 - **The AC line circuit breaker or fuse is blown:** A defective circuit breaker or fuse, an overloaded circuit, or a charger problem can cause this condition. Try connecting the charger to a different AC outlet (on a different circuit) in the building. If the AC supply is sufficient, the charger should be replaced.

Table 4.1 Standard and Optional Features - ANSI/CSA





Models	3215	3219	3220	3226	4620	4626	4632
STANDARD EQUIPMENT							
Platform controls	*	*	*	*	*	*	*
Base controls	*	*	*	*	*	*	*
Drivable at full height	*	*	*	*	*	*	*
Positive traction	*	*	*	*	*	*	*
Dual holding brakes	*	*	*	*	*	*	*
Battery charge indicator	*	*	*	*	*	*	*
Battery level indicator	*	*	*	*	*	*	*
Low voltage battery protection	*	*	*	*	*	*	*
Color coded and numbered wiring system	*	*	*	*	*	*	*
Swing out trays for easy access	*	*	*	*	*	*	*
Proportional control for drive/lift with joystick control	*	*	*	*	*	*	*
Tilt alarm with drive/lift cut out	*	*	*	*	*	*	*
GFI AC outlet on platform	*	*	*	*	*	*	*
Fall Protection Anchorages	*	*	*	*	*	*	*
Forklift pockets/tie downs/lifting lugs	*	*	*	*	*	*	*
Hydraulic oil level and temperature indicators	*	*	*	*	*	*	*
All motion audible alarm	*	*	*	*	*	*	*
Operator horn	*	*	*	*	*	*	*
Midrail chain entrance	*	*	*	*	*	*	*
Top railing with a midrail & 6" (15 cm) toeboard	*	*	*	*	*	*	*
Hourmeter	*	*	*	*	*	*	*
Hinged railing system				*		*	*
Variable front wheel hydraulic drive	*	*					
Variable rear wheel hydraulic drive			*	*	*	*	*
Freewheeling valve	*	*	*	*	*	*	*
Pothole protection	*	*	*	*	*	*	*
3' (0.9 m) Extension deck	*	*	*	*			
4' (1.2 m) Extension deck					*	*	*
OPTIONAL EQUIPMENT							
Flashing Light	*	*	*	*	*	*	*
Shop air line to platform	*	*	*	*	*	*	*
Spring loaded half or full gate entry**	*	*	*	*	*	*	*
Hinged railing system	*	*	*		*		
5' (1.5 m) Powered extension platform							
6' (1.8 m) Powered extension platform			*		*	*	
EE rating package	*	*	*	*	*	*	*
Inverter	*	*	*	*	*	*	*

60381AI-ANSI

** Full height gate not available with hinged railings on 32xx models



Table 4.2 Owner's Annual Inspection Record

										
 Model Number: _____ Serial Number: _____										
*		20__	20__	20__	20__	20__	20__	20__	20__	20__
**										

1000AB

This decal is located on the scissor assembly. It must be completed after an annual inspection has been completed. Do not use the aerial platform if an inspection has not been recorded in the last 13 months.



	Pictorial	Description
*		Inspection Date
**		Inspector Signature

Table 4.3a Specifications and Features

MODEL	3215	3219	3220	3226
Weight *	2400 lb. 1089 kg	2580 lb. 1170 kg	3510 lb. 1592 kg	4135 lb. 1876 kg
Overall width	32" 0.81 m		32" 0.81 m	
Overall length	70.0" 1.78 m		91" 2.3 m	
Platform Size (inside)	26" x 64" 0.66 m x 1.63 m		28" x 83" 0.71 x 2.1 m	
Height				
Working Height	21' 6.4 m	25' 7.6 m	26' 8.1 m	32' 9.9 m
Platform Elevated Height	15' 4.6 m	19' 5.8 m	20' 6.1 m	26' 7.9 m
Stowed Platform Height	34.5" 0.88 m	39" 0.99 m	38" 0.97 m	45" 1.1 m
Stowed Height (Railings Up)	74" 1.88 m	78.5" 1.99 m	82" 2.1 m	89" 2.3 m
Drive Height	FULL			
Standard Operating Time				
Lift Time (No Load)	18 s	20 s	27 s	47 s
Lower Time (No Load)	32 s	39 s	41 s	63 s
Lift Time (Rated Load)	17 s	18 s	27 s	47 s
Lower Time (Rated Load)	26 s	32 s	32 s	54 s
Chassis				
Normal Drive Speed	2.60 mph 4.2 km/h		2.1 mph 3.4 km/h	2.64 mph 3.8 km/h
Elevated Drive Speed	0.62 mph 1.0 km/h		0.62 mph 1.0 km/h	0.62 mph 1.0 km/h
High Torque Drive Speed	N/A		1.20 mph 1.9 km/h	1.44 mph 2.3 km/h
Gradeability (Ramp Angle)	23%		25%	
Tires	12 x 4 x 8 Solid Rubber		16 x 5 x 12 Solid Rubber	
Hydraulic Oil				
Type	ATF Dexron III		ATF Dexron III	
Tank Capacity	2.9 gal. 10.9 L		5.8 gal. 24 L	

SJIII T4.3a_AE-133173AM

* Weight with standard 3' (0.9 m) or 4' (1.2 m) extension platform.

Refer to nameplate for aerial platforms with 5' (1.5 m) or 6' (1.8 m) extension platform.

Table 4.3b Specifications and Features

MODEL	4620	4626	4632
Weight *	4100 lb. 1860 kg	4700 lb. 2132 kg	5075 lb. 2302 kg
Overall width	46" 1.17 m		
Overall length	91" 2.31 m		
Platform Size (inside)	42" x 84" 1.07 m x 2.13 m		
Height			
Working Height	26' 7.92 m	32' 9.75 m	38' 11.6 m
Platform Elevated Height	20' 6.1 m	26' 7.9 m	32' 9.8 m
Stowed Platform Height	38" 0.97 m	45" 1.14 m	48.5" 1.23 m
Stowed Height Railings Up	77.25" 1.96 m	84.5" 2.15 m	88" 2.24 m
Drive Height	FULL		
Standard Operating Time			
Lift Time (No Load)	24 s	48 s	50 s
Lower Time (No Load)	48 s	45 s	62 s
Lift Time (Rated Load)	32 s	49 s	54 s
Lower Time (Rated Load)	32 s	37 s	57 s
Chassis			
Normal Drive Speed	2.20 mph 3.5 km/h		
Elevated Drive Speed	0.56 mph 0.90 km/h		
High Torque Drive Speed	1.20 mph 1.9 km/h		
Gradeability	25%		
Tires	16 x 5 x 12 Solid Rubber		
Hydraulic Oil			
Type	ATF Dexron III		
Tank Capacity	5.8 gal. 24 L		

SJIII T4.3b_AF-133173AM

* Weight with standard 3' (0.9 m) or 4' (1.2 m) extension platform.
Refer to serial nameplate for specific applications.

¹ Fill hardness: 55 Durometer

Table 4.4 Floor Loading Pressure

MODEL		Total Aerial Platform Weight		Total Aerial Platform Load					
				Wheel		LCP**		OUP**	
		lb.	kg	lb.	kg	psi	KPa (kN/m ²)	psf	KPa (kN/m ²)
3215	min*	2400	1089	960	435	100	689.5	160	7.5
	max*	3000	1361	1200	544	110	758.5	200	9.5
3219	min*	2580	1170	1032	468	100	689.5	170	8.0
	max*	3130	1420	1252	568	110	758.5	210	10.0
3220	min*	3400	1542	1396	633	110	758.5	175	8.5
	max*	4299	1950	1936	878	130	896.5	245	11.5
3226	min*	4100	1860	1644	746	120	827.5	210	10.0
	max*	4610	2091	1844	836	130	896.5	235	11.5
4620	min*	4100	1860	1640	744	191	1316.9	146	7.0
	max*	5620	2549	2251	1021	222	1530.6	199	9.5
4626	min*	4700	2132	1880	853	206	1420.3	168	8.0
	max*	5920	2685	2370	1075	224	1544.4	210	10.1
4632	min*	5075	2302	2030	921	208	1434.1	180	8.6
	max*	5775	2620	2310	1048	223	1537.5	205	9.8

SJIII T4.4AE - 133173AM

* **min** - Total aerial platform weight with no options

max - Aerial platform weight + all options + full capacity

** **LCP - Locally Concentrated Pressure** is a measure of how hard the aerial platform presses on the areas in direct contact with the floor. The floor covering (tile, carpet, etc.) must be able to withstand more than the indicated values above.

OUP - Overall Uniform Pressure is a measure of the average load the aerial platform imparts on the whole surface directly underneath it. The structure of the operating surface (beams, etc.) must be able to withstand more than the indicated values above.

NOTE:

The **LCP** or **OUP** that an individual surface can withstand varies from structure to structure and is generally determined by the engineer or architect for that particular structure.

Floor Loading Pressure

Locally Concentrated Pressure (LCP):

Foot Print Area identified by test.

$$LCP = \frac{\text{Wheel Load}}{\text{Foot Print Area}}$$

Overall Uniform Pressure (OUP):

Base Area = Length x Width

$$OUP = \frac{\text{Weight of Aerial Platform} + \text{Capacity}}{\text{Base Area}}$$

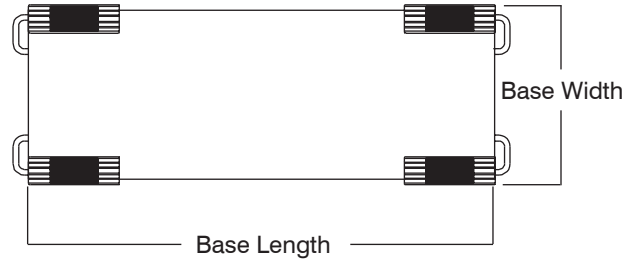
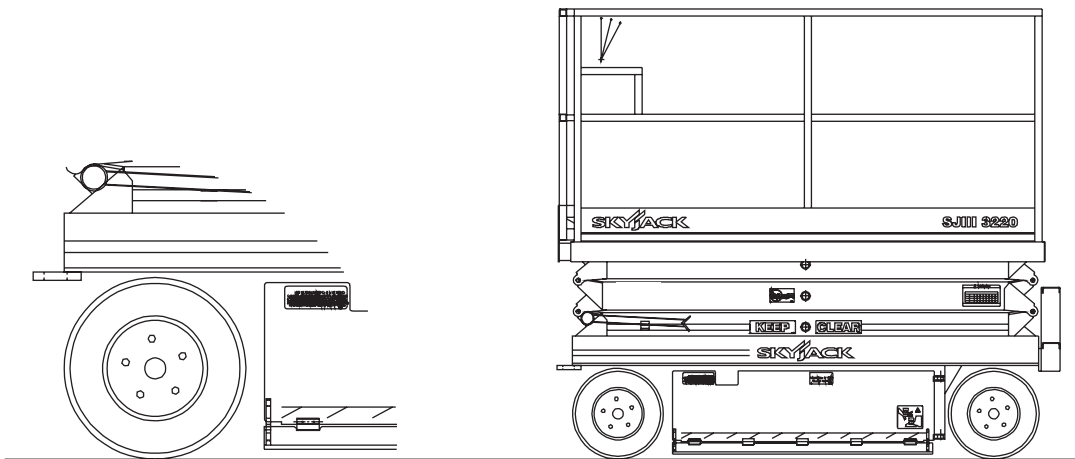

WARNING

Intermixing tires of different types or using tires of types other than those originally supplied with this equipment can adversely affect stability. Therefore, replace tires only with the exact Skyjack-approved type. Failure to operate with matched approved tires in good condition may result in death or serious injury.

Table 4.5 Maximum Platform Capacities (Evenly Distributed)

MODEL	Manual Extension Platform				Powered Extension Platform				Maximum Wind Speed	Tilt Cutout Setting (Degrees)
	Total Capacity		Extension Capacity		Total Capacity		Extension Capacity			
3215	600 lb. 272 kg	2 Persons	250 lb. 113 kg	1 Person	N/A				28 mph 12.5 m/s	1.5 x 3.5
3219	550 lb. 249 kg	2 Persons	250 lb. 113 kg	1 Person	N/A				28 mph 12.5 m/s	1.5 x 3.5
3220	900 lb. 408 kg	2 Persons	300 lb. 136 kg	1 Person	800 lb. 363 kg	2 Persons	300 lb. 136 kg	1 Person	28 mph 12.5 m/s	1.5 x 3.5
3226	500 lb. 227 kg	2 Persons	250 lb. 113 kg	1 Person	N/A				28 mph 12.5 m/s	1.5 x 3.5
4620	1300 lb. 590 kg	3 Persons	300 lb. 136 kg	1 Person	1300 lb. 590 kg	3 Persons	300 lb. 136 kg	1 Person	28 mph 12.5 m/s	2.5 x 4.5
4626	1000 lb. 454 kg	3 Persons	300 lb. 136 kg	1 Person	1000 lb. 454 kg	3 Persons	300 lb. 136 kg	1 Person	28 mph 12.5 m/s	2.5 x 4.5
4632	700 lb. 318 kg	2 Persons	250 lb. 113 kg	1 Person	N/A				28 mph 12.5 m/s	2.5 x 4.5

SJIII T4.5AC - 133173AM

General Maintenance

Before attempting any repair work, disconnect the battery by turning the main power disconnect switch to “○” off position. Preventive maintenance is the easiest and least expensive type of maintenance.

Table 4.6 Maintenance and Inspection Schedule

Frequency	Daily	3 months or 150 hours	Yearly	Frequency	Daily	3 months or 150 hours	Yearly
Visual and Daily Maintenance Inspections				Platform Assembly			
Labels	A			Fall Protection Anchorages	A		
Electrical	A			AC Outlet on Platform	A		
Limit Switches	A			Platform Control Console	A		
Hydraulic	A			Manuals	A		
Entrance Side				Powered Extension Control Console (If Equipped)	A		
Main Power Disconnect Switch	A			Lifting Mechanism			
Base Control Switches	A			Maintenance Support	A		
Free-wheeling Value Knob	A			Scissor Assembly	A		
Brakes	A			Scissor Bumpers	A		
110V/220V Outlet Receptacle	A			Rollers	A		
Ladder	A			Lift Cylinder(s)	A		
Battery Tray Side				Function Tests			
Pothole Protection Device	A			Test Main Power Disconnect Switch	A		
Battery Tray	A			Base Control Console			
Battery Charger	A			Test Base Emergency Stop	A		
Battery	A			Test Off/Platform/Base Switch	A		
Steer Cylinder Assembly	A			Test Lower/Neutral/Raise Switch	A		
Wheel/Tire Assembly	A			Test Emergency Lowering	A		
Tie Rod (Conventionals)	A			Test Free-wheeling	A		
Greasing Points	A			Platform Control Console			
Hydraulic/Electric Tray Side				Test Platform Emergency Stop	A		
Pothole Protection Device	A			Test Enable Trigger Switch	A		
Hydraulic Tank	A			Test Steering	A		
Hydraulic Oil	A			Test Driving	A		
Hydraulic Pump and Motor	A			Test Brakes	A		
Wheel/Tire Assembly	A			Test Platform Raising/Lowering	A		
Electrical Panel	A			Test Lowering Warning (If Equipped)	A		
Proportional and Main Manifolds	A			Test Horn	A		
Load/Tilt Sensor	A			Test Load Sensing (If Equipped)	A		
Emergency Lowering Access Rod (If Equipped)	A			Test Pothole Sensor	A		
				Test Elevated Drive Speed	A		

60598AH

A - Perform Visual and Daily Maintenance Inspections & Functions Test. Refer to Section 2.3 and Section 2.4 of this manual.

B - Perform Scheduled Maintenance Inspection. Refer to Service & Maintenance manual.

* - Maintenance must be performed only by trained and competent personnel who are familiar with mechanical procedures.



WARNING

Use original or equivalent to the original parts and components for the aerial platform.

Table 4.7 Operator’s Checklist



Serial Number: _____
 Model: _____
 Hourmeter Reading: _____
 Date: _____
 Time: _____

Operator's Name (Printed): _____
 Operator's Signature: _____

Each item shall be inspected using the appropriate section of the Skyjack operating manual. As each item is inspected, check the appropriate box.

- P** - PASS
- F** - FAIL
- R** - REPAIRED
- NA** - NOT APPLICABLE

INSPECTION FREQUENCY

- FREQUENTLY
- DAILY
- ANNUALLY
- BI-ANNUALLY

	N/A	P	F	R
Visual and Daily Maintenance Inspections				
Labels				
Electrical				
Limit Switches				
Hydraulic				
Entrance Side				
Main Power Disconnect Switch				
Base Control Switches				
Free-wheeling Valve Knob				
Brakes				
110V Outlet Receptacle				
Ladder				
Battery Tray Side				
Pothole Protection Device				
Battery Tray				
Battery Charger				
Battery				
Steer Cylinder Assembly				
Wheel/Tire Assembly				
Tie Rod (Conventionals)				
Greasing Points				
Hydraulic/Electric Side				
Pothole Protection Device				
Hydraulic Tank				
Hydraulic Oil				
Hydraulic Pump and Motor				
Wheel/Tire Assembly				
Electrical Panel				
Proportional and Main Manifolds				
Tilt Sensor				
Emergency Lowering Access Rod (If Equipped)				

	N/A	P	F	R
Platform Assembly				
Fall Protection Anchorages				
Lifting Mechanism				
Maintenance Support				
Scissor Assembly				
Scissor Bumpers				
Lifting Mechanism				
Maintenance Support				
Scissor Assembly				
Scissor Bumpers				
Rollers				
Lift Cylinder(s)				
Function Tests				
Test Main Power Disconnect Switch				
Base Control Console				
Test Base Emergency Stop				
Test Off/Platform/Base Switch				
Test Lower/Neutral/Raise Switch				
Test Emergency Lowering				
Test Free-wheeling				
Platform Control Console				
Test Platform Emergency Stop				
Test Enable Trigger Switch				
Test Steering				
Test Driving				
Test Brakes				
Test Platform Raising/Lowering				
Test Horn				
Test Pothole Sensor				
Test Speed Limit				

60600AH-ANSI-R

Note:
 Make a copy of this page or visit the Skyjack web site:
www.skyjack.com for a printable copy.

Label Legend

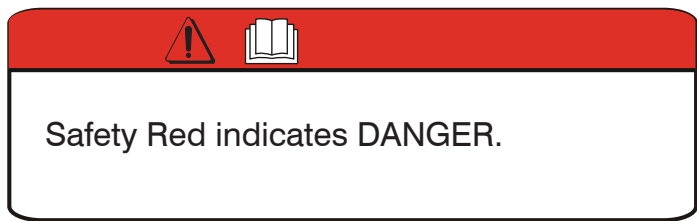

Safety Red indicates DANGER.

Safety Red

The diagram shows a red horizontal bar at the top of a rounded rectangular box. Inside the bar are two white icons: a warning triangle and an open book. Below the bar, the text 'Safety Red indicates DANGER.' is centered. To the right of the box, the text 'Safety Red' is written with a curved arrow pointing to the red bar.



Safety Orange indicates WARNING.

Safety Orange

The diagram shows an orange horizontal bar at the top of a rounded rectangular box. Inside the bar are two white icons: a warning triangle and an open book. Below the bar, the text 'Safety Orange indicates WARNING.' is centered. To the right of the box, the text 'Safety Orange' is written with a curved arrow pointing to the orange bar.

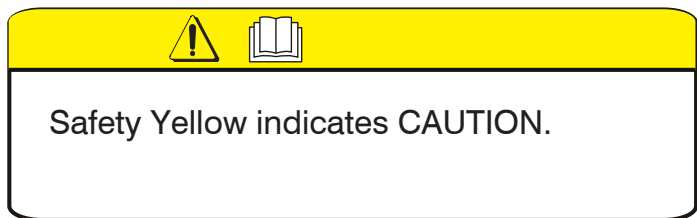

Safety Yellow indicates CAUTION.

Safety Yellow

The diagram shows a yellow horizontal bar at the top of a rounded rectangular box. Inside the bar are two white icons: a warning triangle and an open book. Below the bar, the text 'Safety Yellow indicates CAUTION.' is centered. To the right of the box, the text 'Safety Yellow' is written with a curved arrow pointing to the yellow bar.

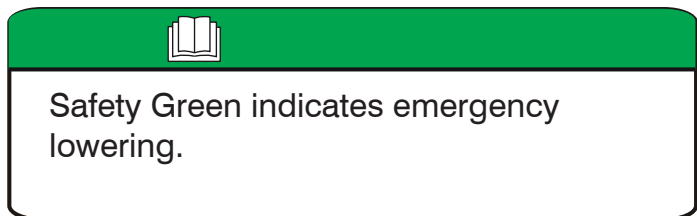

Safety Green indicates emergency lowering.

Safety Green

The diagram shows a green horizontal bar at the top of a rounded rectangular box. Inside the bar is one white icon: an open book. Below the bar, the text 'Safety Green indicates emergency lowering.' is centered. To the right of the box, the text 'Safety Green' is written with a curved arrow pointing to the green bar.

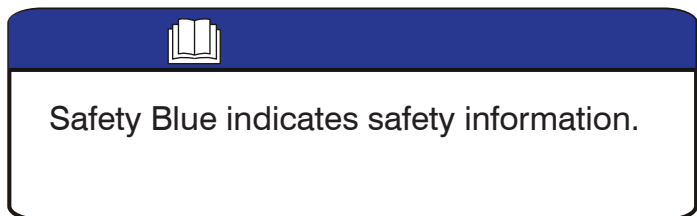





Safety Blue indicates safety information.

Safety Blue

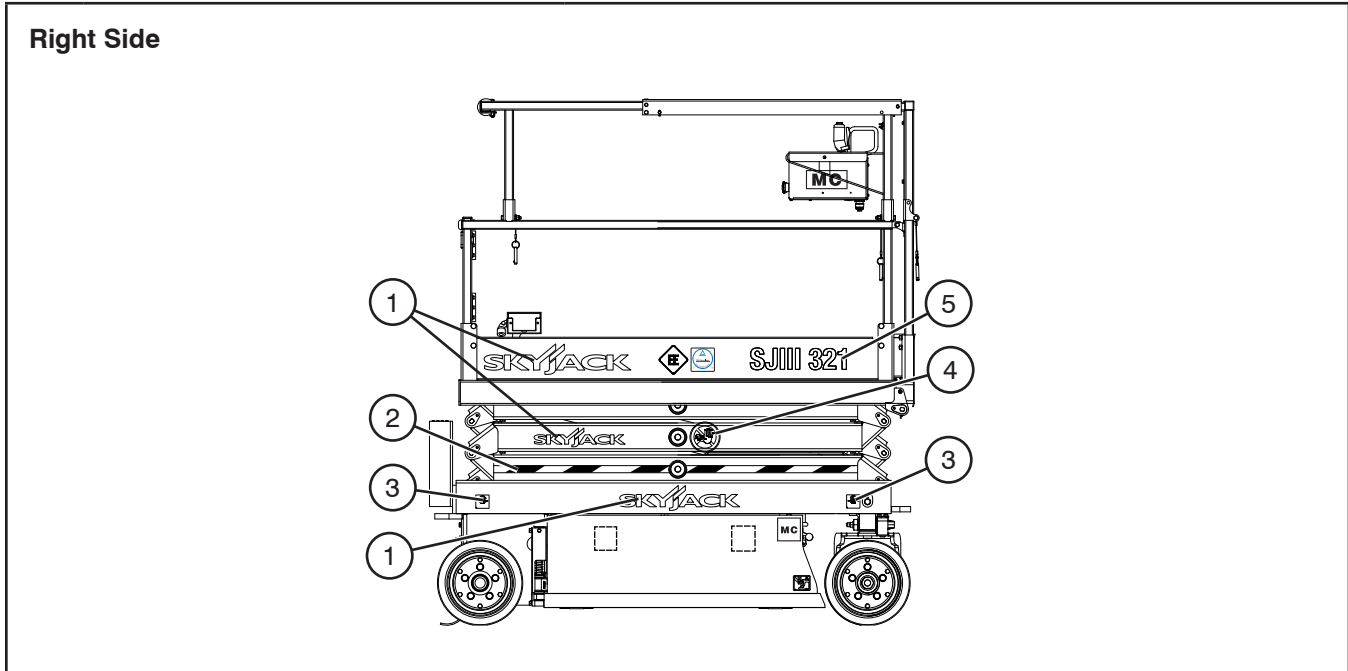
The diagram shows a blue horizontal bar at the top of a rounded rectangular box. Inside the bar is one white icon: an open book. Below the bar, the text 'Safety Blue indicates safety information.' is centered. To the right of the box, the text 'Safety Blue' is written with a curved arrow pointing to the blue bar.



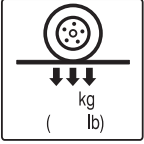



Labels and Nameplates - Models 3215 & 3219

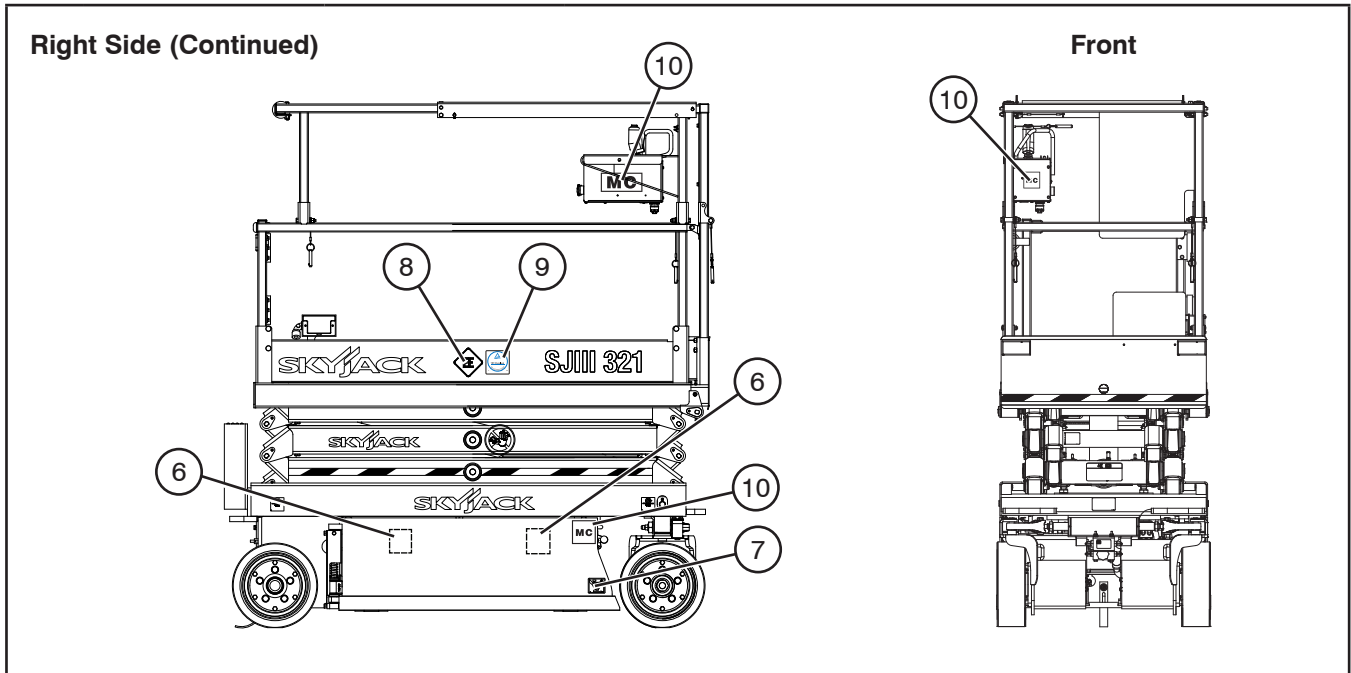

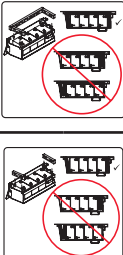
No.	Label Pictorial	Description
1		<p>Skyjack Logo</p> <p>Skyjack</p>
2		<p>Caution Tape Stripe</p> <p>Caution stripe</p>
3		<p>Wheel Load*</p> <p>Indicates rated wheel load. *Wheel load will vary with each model.</p>
4		<p>Keep Clear</p> <p>Keep clear. Stay away from aerial platform when in operation.</p>
5		<p>Model Number*</p> <p>Product Identifier *Model number will vary, may not be as shown.</p>

Labels and Nameplates - Models 3215 & 3219



No.	Label Pictorial	Description
6		<p>Battery Spacers*</p> <p>Place spacers only as shown in diagram. *Spacers vary over different aerial platforms.</p>
7		<p>Crushing Hazard</p> <p>Danger - Crushing hazard</p>
8		<p>EE Rating (If Equipped)**</p> <p>Indicates EE-rating for EE-rated aerial platforms.</p> <p>** Note: This label only applies to aerial platforms which are EE rated, and may not appear on all units.</p>
9		<p>TUV Certification (If Equipped)**</p> <p>Indicates TUV certification.</p> <p>** Note: This label only applies to aerial platforms which are EE rated, and may not appear on all units.</p>
10	 	<p>Motor Controller</p> <p>Indicates motor controller aerial platform.</p>

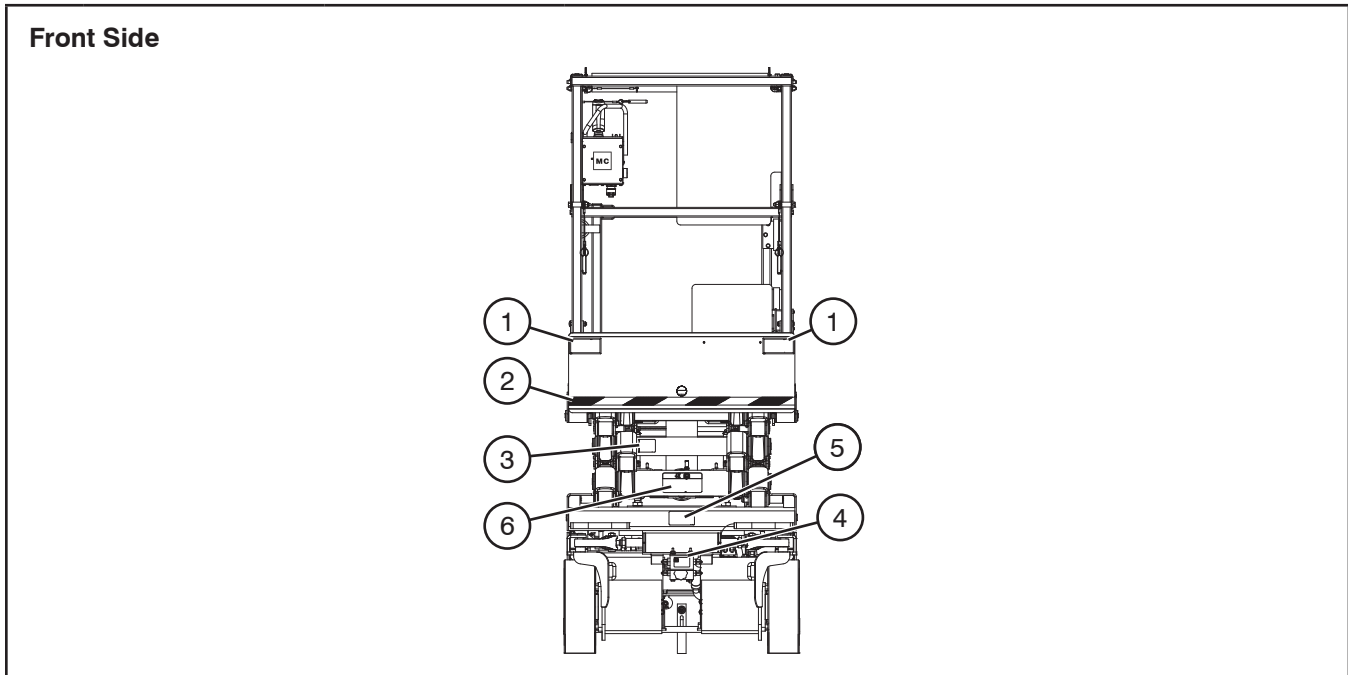

Labels and Nameplates - Models 3215 & 3219

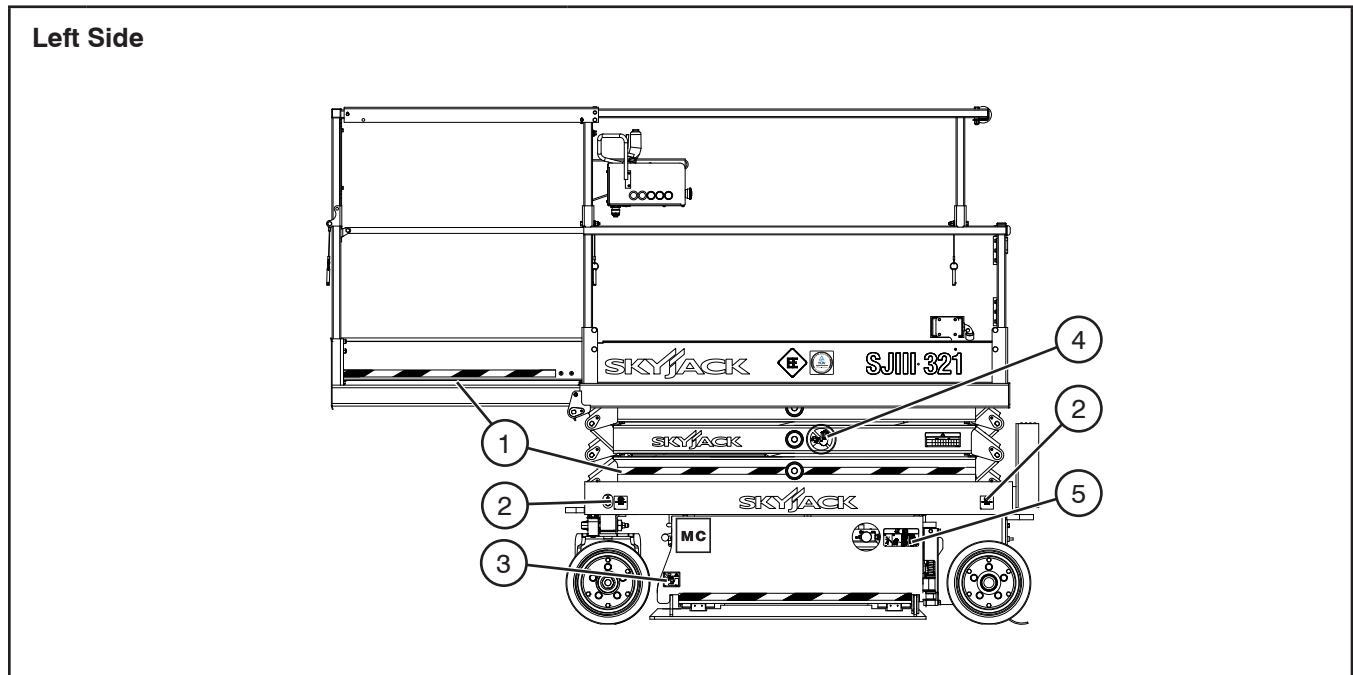

No.	Label Pictorial	Description
1		Crushing Hazard Danger - Crushing hazard
2		Caution Tape Stripe Caution stripe
3		Maintenance Support Deploy maintenance support here.
4		Refer to the Operating manual for Free-wheeling Procedure. Open free-wheeling valve by turning counterclockwise. Close free-wheeling valve by turning clockwise.
5		Lift and Tie Down Points Only use these points for lifting or tying down.
6		Emergency Lowering Procedure Refer to Operating manual. 1. Turn main power disconnect switch to off position. 2. To open lift cylinder holding valve located at the bottom of the cylinder: (A) push (B) turn knurled knob counterclockwise. 3. To lower the platform, pull out emergency lowering valve located on the outside of the hydraulic tray.

Labels and Nameplates - Models 3215 & 3219

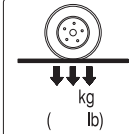

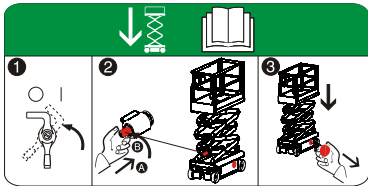
No.	Label Pictorial	Description
1		<p>Caution Tape Stripe Caution stripe</p>
2		<p>Wheel Load* Indicates rated wheel load. *Wheel load will vary with each model.</p>
3		<p>Crushing Hazard Danger - Crushing hazard</p>
4		<p>Keep Clear Keep clear. Stay away from aerial platform when in operation.</p>
5		<p>Emergency Lowering Procedure Refer to Operating manual.</p> <ol style="list-style-type: none"> 1. Turn main power disconnect switch to off position. 2. To open lift cylinder holding valve located at the bottom of the cylinder: <ol style="list-style-type: none"> (A) push (B) turn knurled knob counterclockwise. 3. To lower the platform, pull out emergency lowering valve located on the outside of the hydraulic tray.

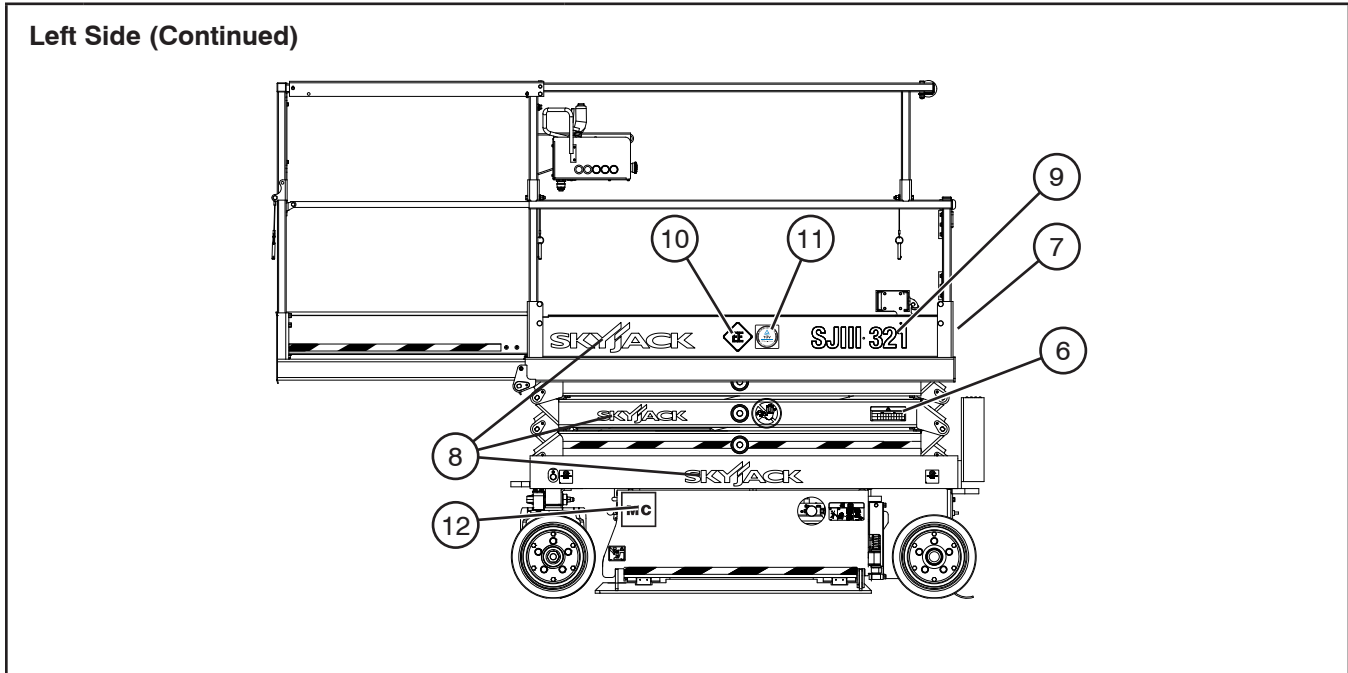

Labels and Nameplates - Models 3215 & 3219

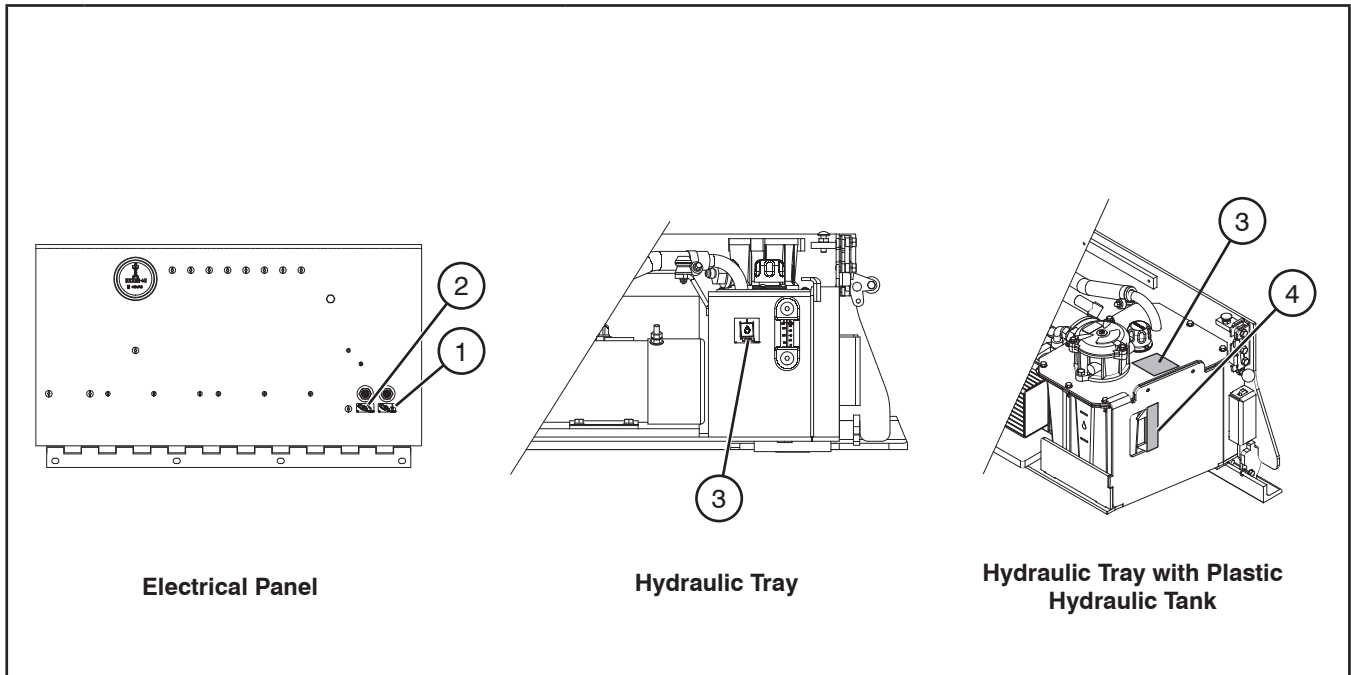

No.	Label Pictorial	Description
6		<p>Annual Inspection</p> <p>Ensure that work platform has received annual inspection prior to operation.</p>
7		<p>Fall Protection Anchorage</p> <p>Rated for one (1) person per anchorage.</p>
8		<p>Skyjack Logo</p> <p>Skyjack</p>
9		<p>Model Number*</p> <p>Product Identifier *Model number will vary, may not be as shown.</p>
10		<p>EE Rating (If Equipped)**</p> <p>Indicates EE-rating for EE-rated aerial platforms.</p> <p>** Note: This label only applies to aerial platforms which are EE rated, and may not appear on all units.</p>
11		<p>TUV Certification (If Equipped)**</p> <p>Indicates TUV certification.</p> <p>** Note: This label only applies to aerial platforms which are EE rated, and may not appear on all units.</p>
12		<p>Motor Controller</p> <p>Indicates motor controller aerial platform.</p>

Labels and Nameplates - Models 3215 & 3219

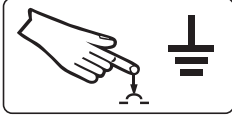
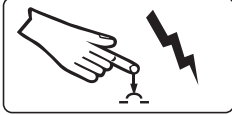
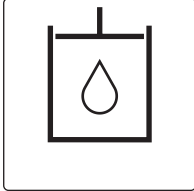

No.	Label Pictorial	Description
1		<p>Ground Circuit Breaker</p> <p>Push to reset ground circuit breaker.</p>
2		<p>Power Circuit Breaker</p> <p>Push to reset power circuit breaker.</p>
3		<p>Hydraulic Oil ATF Dexron III</p> <p>Replace hydraulic fluid with ATF Dexron III only.</p>
4		<p>Hydraulic Oil Level</p>

Labels and Nameplates - Models 3215 & 3219

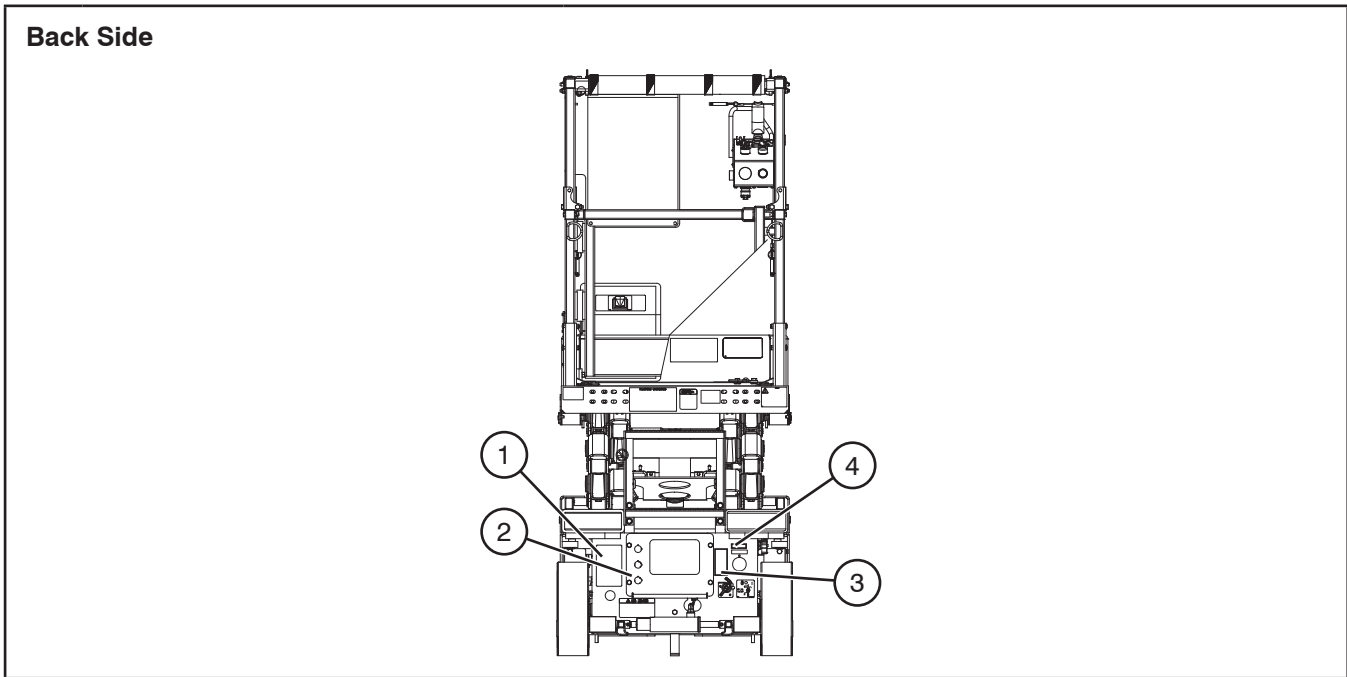

No.	Label Pictorial	Description
1		<p>Serial Plate*</p> <p>Product identification and specifications *Serial plates will vary, may not be as shown.</p>
2		<p>Base Controls</p> <p>Select “ ↓” to lower or “ ↑” raise platform.</p> <p>Select “ ” platform to enable platform controls, “ ” off to disable controls or “ ” base to enable base control console.</p> <p>Push “ ” to disable controls.</p>
3		<p>Warning - Connect Charger for EE Rated Aerial Platform (If Equipped)</p> <p>Do not charge batteries in hazardous area.</p>
4		<p>Warning - AC Power for EE Rated Aerial Platform (If Equipped)</p> <p>Do not use AC power in hazardous locations.</p>

Labels and Nameplates - Models 3215 & 3219

Back Side (Continued)

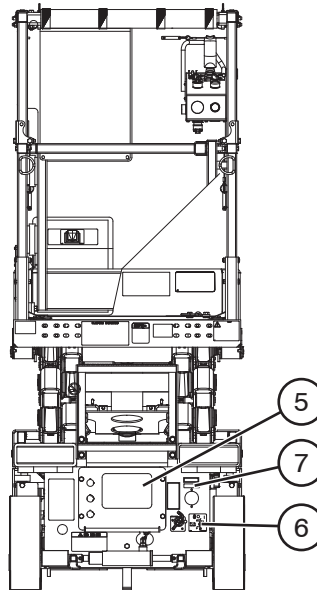

No.	Label Pictorial	Description
5	<p>The pictorial for label 5 shows a rectangular label with various symbols and text. On the left, there are CE and Bf certification marks. Below these is the SKYJACK logo. At the bottom, there are three circles and several warning symbols. On the right side of the label, there is a small table with columns for 'Serial No.', 'Date', and 'Name'.</p>	<p>Charger Information</p> <p>Charger specification information and operation status; consult manual.</p>
6	<p>The pictorial for label 6 shows a square frame containing three symbols: a padlock, a power button symbol, and a hand turning a knob.</p>	<p>Main Power Disconnect</p> <p>Rotate clockwise to turn on main power; rotate counterclockwise to turn off main power; insert padlock to lock in position.</p>
7	<p>The pictorial for label 7 shows a rectangular frame containing three symbols: a circular AC outlet, a hand plugging a cord into it, and a lightning bolt symbol with the letters 'AC' next to it.</p>	<p>Connect Platform AC Supply</p> <p>Connect AC power supply here for platform accessory outlet.</p>

Labels and Nameplates - Models 3215 & 3219

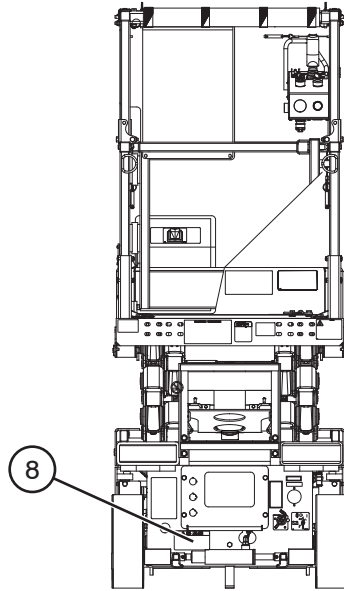

Back Side (Continued)

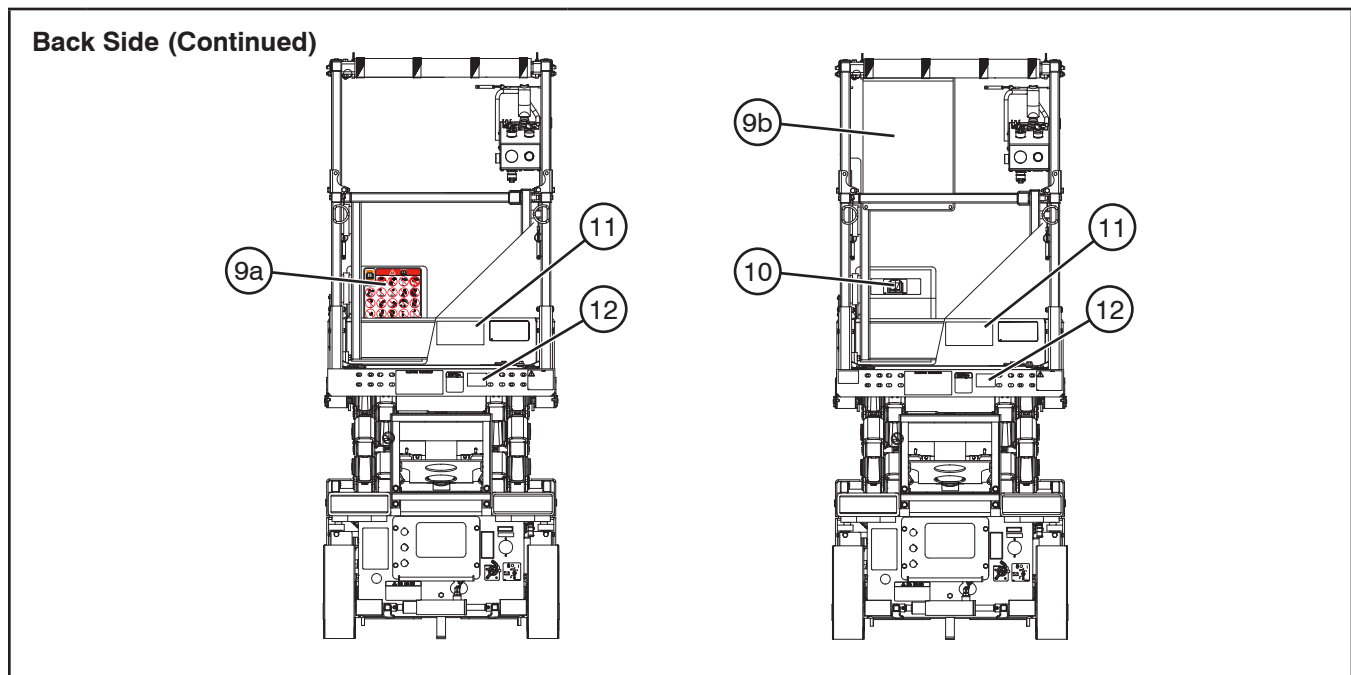

No.	Label Pictorial	Description
8		<p>Winching/Towing/Pushing Procedure Refer to Operating manual.</p> <ol style="list-style-type: none"> 1. Block or chock wheels to prevent aerial platform from rolling. 2. Turn main power disconnect switch to off position. 3. Locate pin brake cylinders. 4. Using a 3/4" (19mm) wrench, rotate the block on each brake pin 90 degrees. Brakes are now released. 5. Open free-wheeling valve by turning counterclockwise. 6. Push/tow/winches to desired location. 7. Block or chock wheels to prevent aerial platform from rolling. 8. Close free-wheeling valve by turning clockwise. 9. Using a 3/4" (19mm) wrench, rotate the block on each brake pin 90 degrees. Brakes are now engaged.

Labels and Nameplates - Models 3215 & 3219

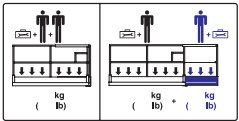

No.	Label Pictorial	Description
9a		<p>Hazard Identification/Manual Storage Box Refer to Section 1: Safety Rules.</p> <p>Read and understand the outlined risks associated with this MEWP prior to operation. Indicates location of operating manual.</p>
9b		<p>Hazard Identification Refer to Section 1: Safety Rules.</p> <p>Read and understand the outlined risks associated with this work platform prior to operation.</p>
10		<p>Manual Storage Box</p> <p>Indicates location of operating manual.</p>
11		<p>Platform Capacity*</p> <p>Rated work load in each configuration is as shown. Rated work load includes the weight of both personnel and material. Maximum number of people in each configuration is as shown. Do not exceed total weight or maximum number of people. Load platform uniformly. *Platform capacity varies over different aerial platforms.</p>
12	<p>NOTICE</p> <p>This aerial platform is equipped with inverter power supply. Main power disconnect switch must be turned to O off position at the end of every shift.</p>	<p>Inverter Switch (If Equipped)</p> <p>Turn inverter switch to off position after use.</p>

Labels and Nameplates - Models 3215 & 3219

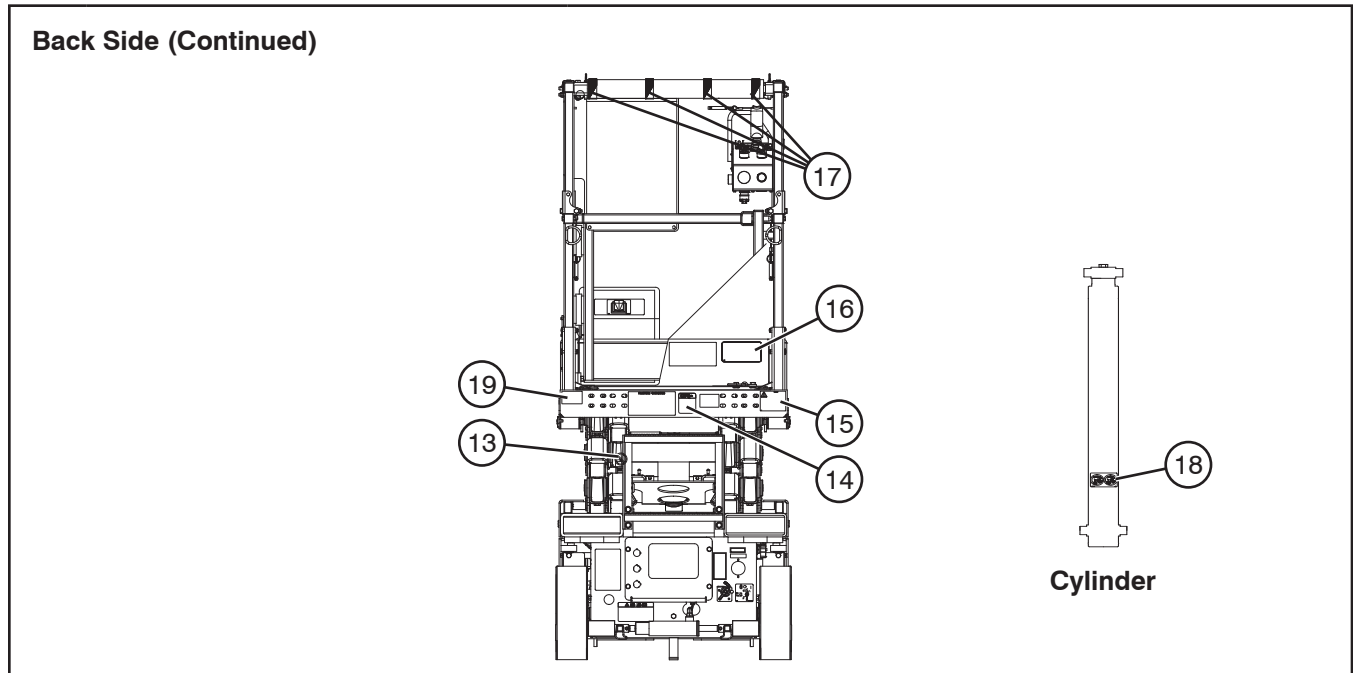

No.	Label Pictorial	Description
13		Warning - Do Not Alter DO NOT alter or disable limit switches or other safety devices.
14		Operator's Daily Inspection Refer to the Operating manual. Perform visual inspection and function tests at the beginning of each shift. Refer to Section 4: Maintenance and Inspection Schedule .
15		No Jewelry Caution - Do not wear jewelry.
16		Horizontal Load Rating* Apply no more than the indicated side load. Operate below indicated wind speed only. *Horizontal load rating will vary, may not be as shown.
17		Caution Tape Stripe Caution stripe
18		Orifice Installed Orifice installation warning
19		Warning - California Proposition 65 Cancer and Reproductive Harm- https://www.p65warnings.ca.gov/ .

Labels and Nameplates - Models 3215 & 3219

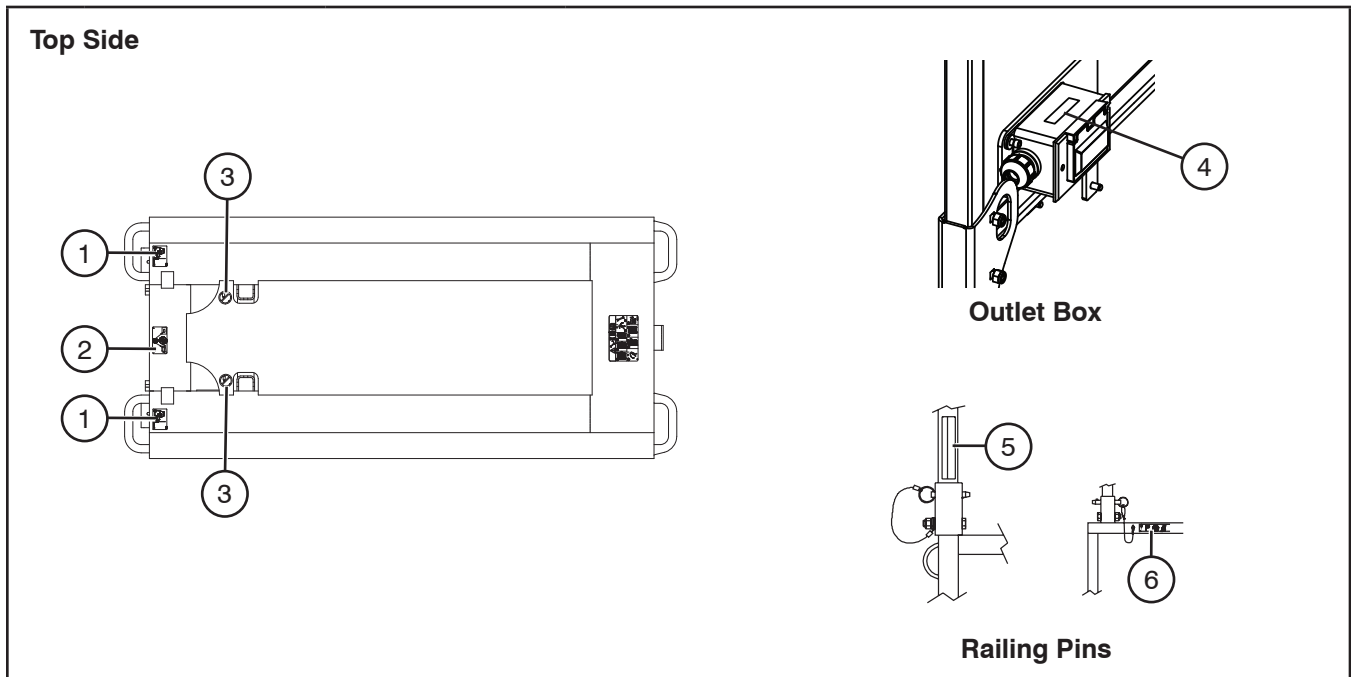

No.	Label Pictorial	Description
1		<p>Forklift Pocket</p> <p>Insert fork fully into pocket to lift aerial platform.</p>
2		<p>Lift and Tie Down Points</p> <p>Only use these points for lifting or tying down.</p>
3		<p>Warning - Do Not Alter</p> <p>DO NOT alter or disable limit switches or other safety devices.</p>
4		<p>Connect Platform AC Supply</p> <p>Connect AC power supply here for platform accessory outlet.</p>
		<p>Warning - AC Power for EE Rated Aerial Platform (If Equipped)</p> <p>Do not use AC power in hazardous locations.</p>
5		<p>Falling Hazard - Railing Pins (Vertical) (If Equipped)</p> <p>WARNING! Falling Hazard. Make sure hinged railing is pinned properly.</p>
6		<p>Falling Hazard - Railing Pins (Horizontal) (If Equipped)</p> <p>WARNING! Falling Hazard. Make sure hinged railing is pinned properly.</p>

Labels and Nameplates - Models 3215 & 3219

Top Side (Continued)

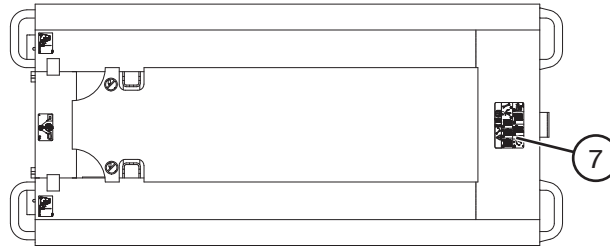

No.	Label Pictorial	Description
7		<p>How to engage maintenance support for inspection or maintenance. Refer to Operating manual.</p> <ol style="list-style-type: none"> 1. Raise platform until there is adequate clearance to swing down maintenance support. 2. Swing maintenance support down from storage bracket into a vertical position. Lower platform until the bottom end of maintenance support rests on the lower cross bar. 3. Maintenance support is now secured. (A) Turn main power disconnect switch to off position. (B) Perform inspection/maintenance. 4. Turn main power disconnect switch to on position. 5. Raise platform until there is adequate clearance to swing up maintenance support. 6. Swing maintenance support up and place into storage bracket. 7. Ensure platform is fully lowered.



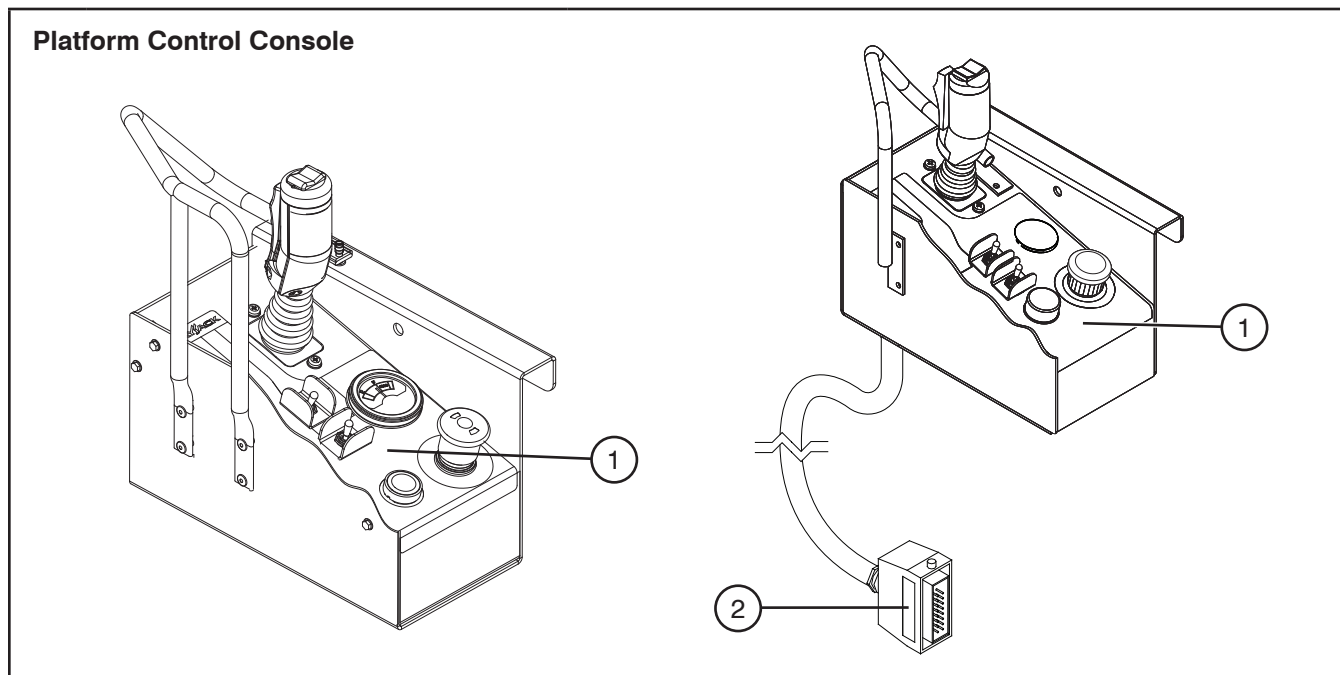

Labels and Nameplates - Models 3215 & 3219

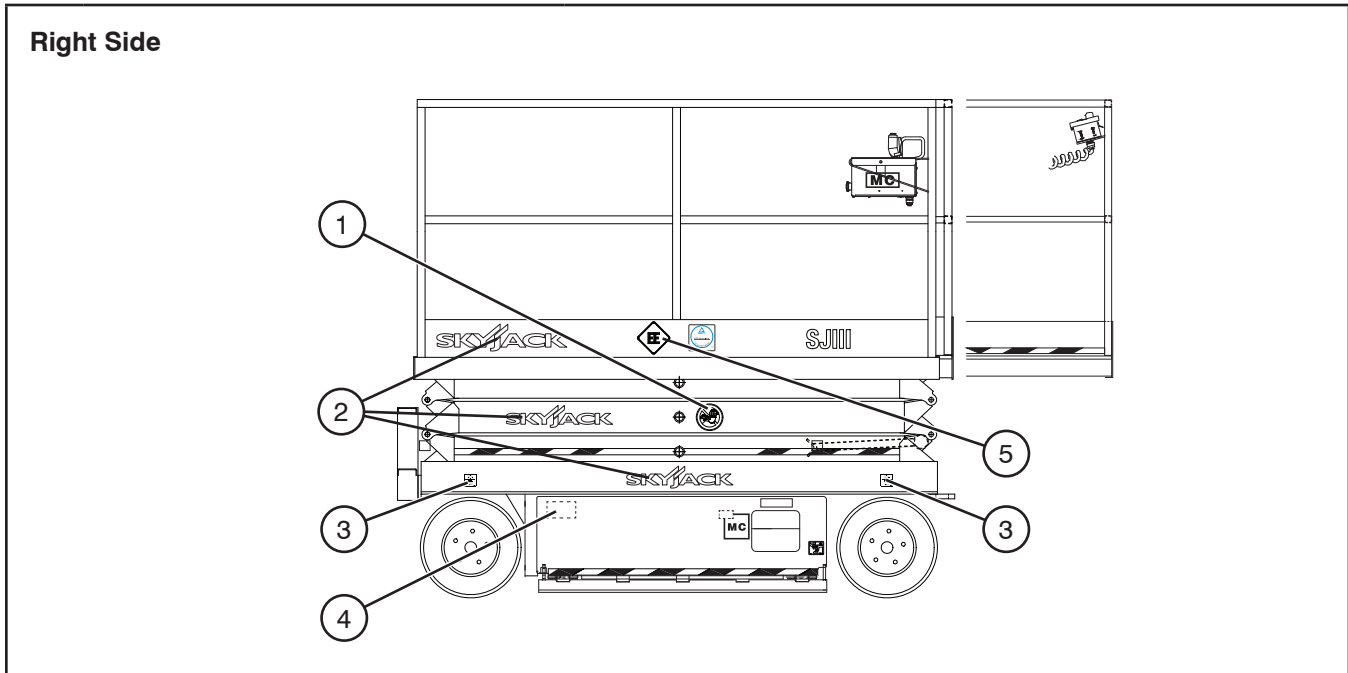

No.	Label Pictorial	Description
1		<p>Platform Controls</p> <p>Squeeze “” trigger to enable controller.</p> <p>Operate “” rocker switch to steer.</p> <p>Move controller handle forward to “” raise or backward to “” lower platform.</p> <p>Move controller handle “” forward to drive forward, or “” backward to drive reverse.</p> <p>Select “” inclined drive (low speed/high torque) or “” level drive (high speed/low torque) mode.</p> <p>Select “” lift, “” off or “” drive mode.</p> <p>Push “” to sound horn.</p> <p>Push “” emergency stop button to disable controls.</p> <p>Read “” operating manual.</p>
2	<p>Hydraulic proportional 3215/19</p>	<p>Hydraulic Proportional (If Equipped)</p> <p>Control box is suitable for use on hydraulic proportional aerial platforms.</p>



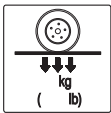
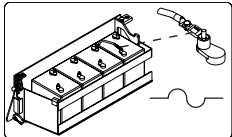



Labels and Nameplates - Models 3220, 3226 & 46xx

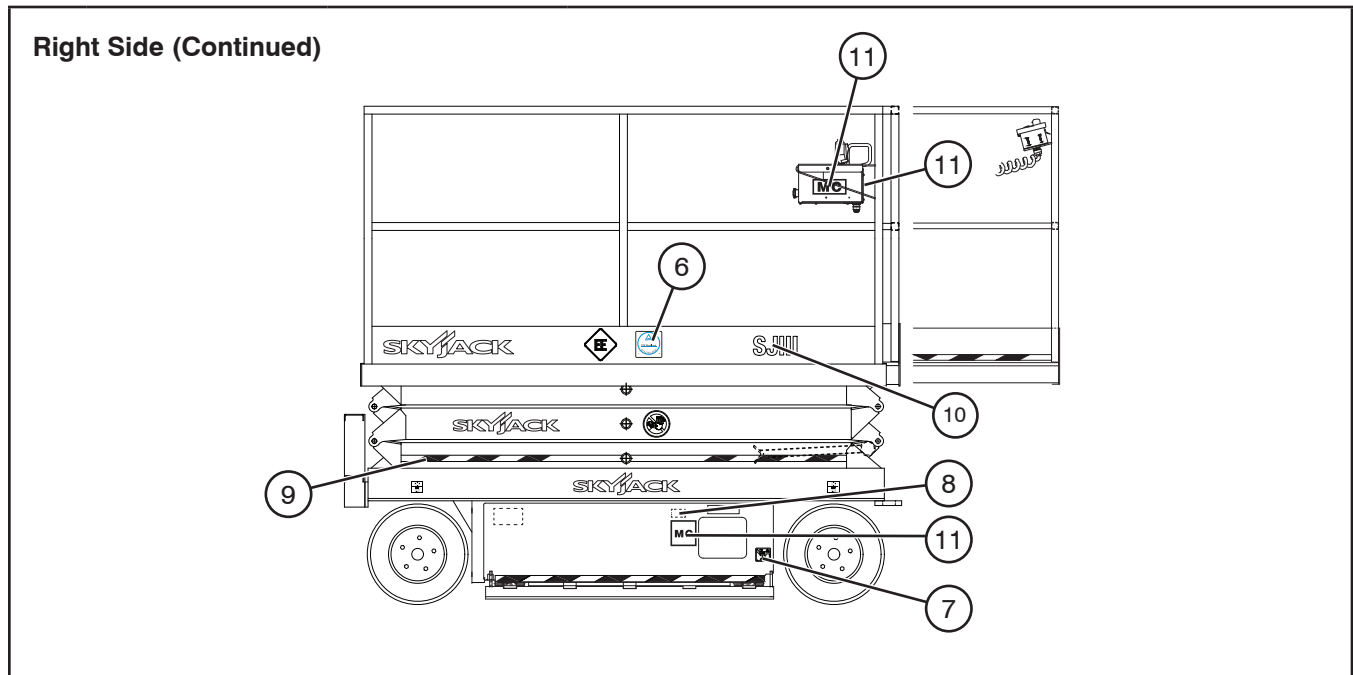

No.	Label Pictorial	Description
1		<p>Keep Clear</p> <p>Keep clear. Stay away from aerial platform when in operation.</p>
2		<p>Skyjack Logo</p> <p>Skyjack</p>
3		<p>Wheel Load*</p> <p>Indicates rated wheel load. *Wheel load will vary with each model.</p>
4		<p>Fuse Location</p> <p>Fuse location</p>
5		<p>EE Rating (If Equipped)**</p> <p>Indicates EE-rating for EE-rated aerial platforms.</p> <p>** Note: This label only applies to aerial platforms which are EE rated, and may not appear on all units.</p>

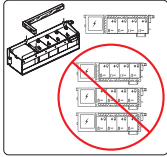

Labels and Nameplates - Models 3220, 3226 & 46xx



No.	Label Pictorial	Description
6		<p>TUV Certification (If Equipped)**</p> <p>Indicates TUV certification.</p> <p>** Note: This label only applies to aerial platforms which are EE rated, and may not appear on all units.</p>
7		<p>Crushing Hazard</p> <p>Danger - Crushing hazard</p>
8		<p>Battery Spacers*</p> <p>Place spacers only as shown in diagram.</p> <p>*Spacers vary over different units.</p>
9		<p>Caution Tape Stripe</p> <p>Caution stripe</p>
10		<p>Model Number*</p> <p>Product Identifier</p> <p>*Model number will vary, may not be as shown.</p>
11	 	<p>Motor Controller</p> <p>Indicates motor controller aerial platform.</p>

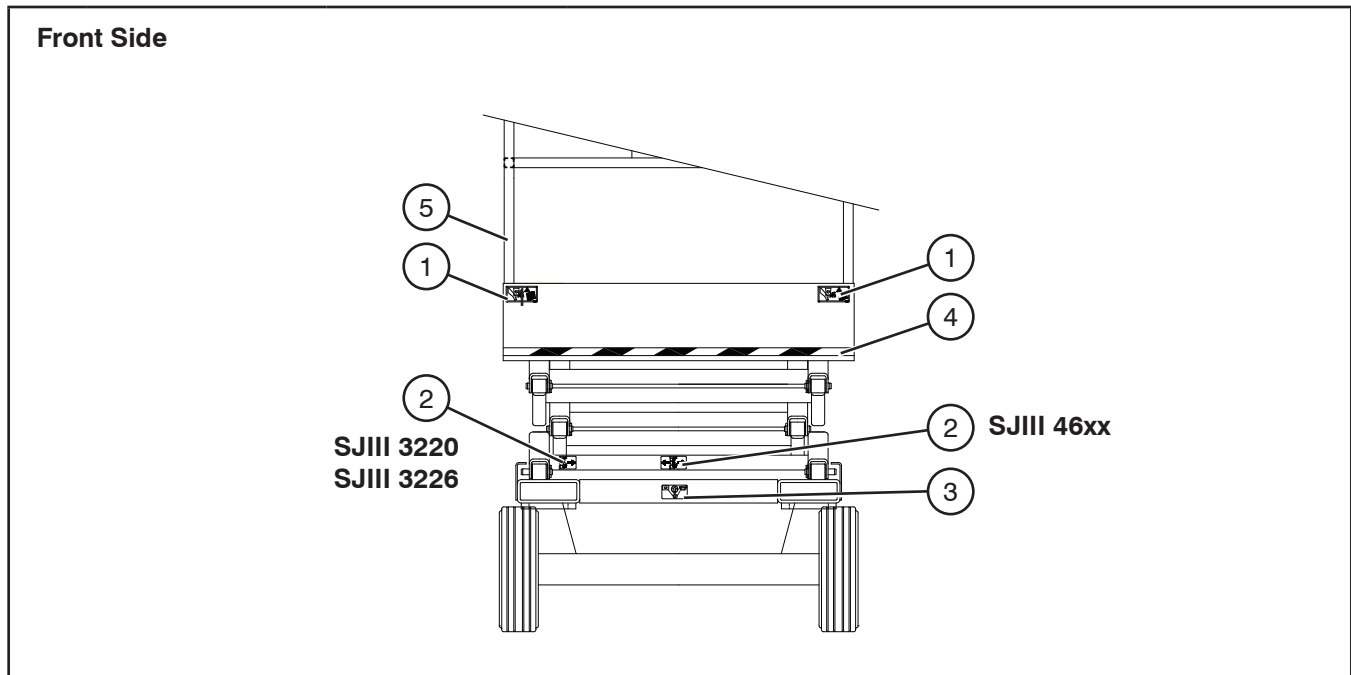

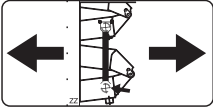
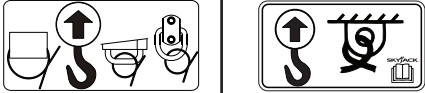

Labels and Nameplates - Models 3220, 3226 & 46xx

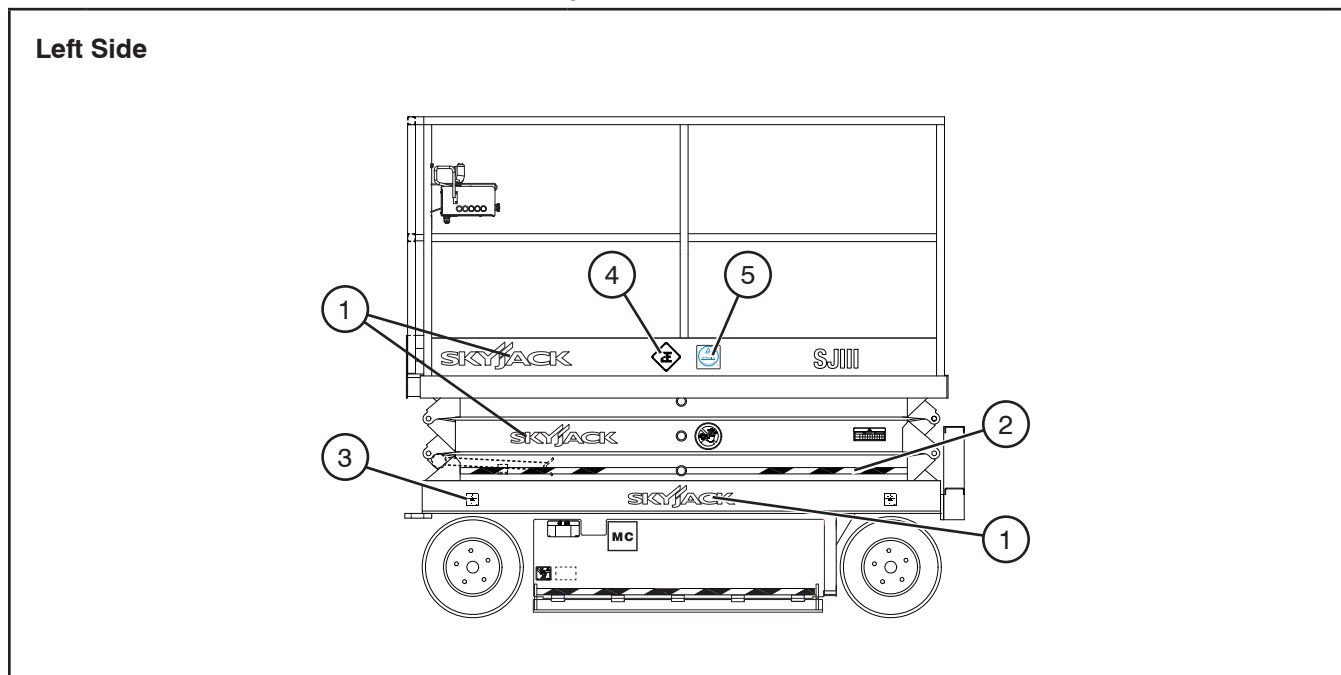

No.	Label Pictorial	Description
1		<p>Crushing Hazard Danger - Crushing hazard</p>
2		<p>Maintenance Support Deploy maintenance support here.</p>
3		<p>Lift and Tie Down Points Only use these points for lifting or tying down.</p>
4		<p>Caution Tape Stripe Caution stripe</p>
5		<p>Fall Protection Anchorage Rated for one (1) person per anchorage.</p>

Labels and Nameplates - Models 3220, 3226 & 46xx

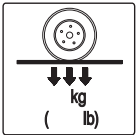



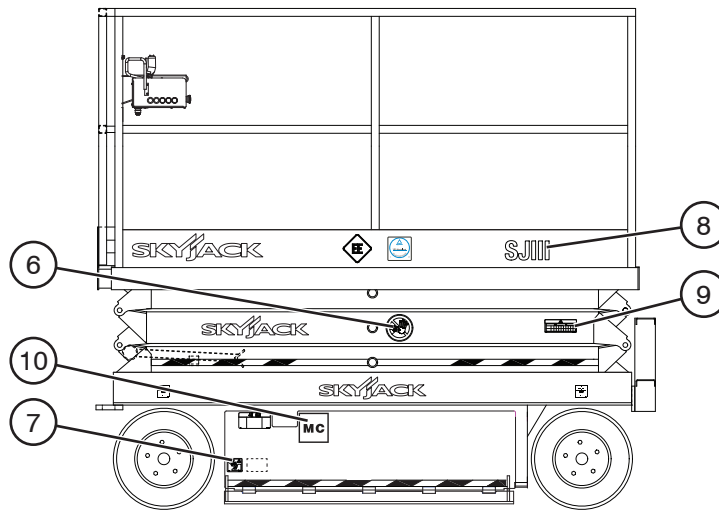

No.	Label Pictorial	Description
1		<p>Skyjack Logo</p> <p>Skyjack</p>
2		<p>Caution Tape Stripe</p> <p>Caution stripe</p>
3		<p>Wheel Load*</p> <p>Indicates rated wheel load. *Wheel load will vary with each model.</p>
4		<p>EE Rating (If Equipped)**</p> <p>Indicates EE-rating for EE-rated aerial platforms.</p> <p>** Note: This label only applies to aerial platforms which are EE rated, and may not appear on all units.</p>
5		<p>TUV Certification (If Equipped)**</p> <p>Indicates TUV certification.</p> <p>** Note: This label only applies to aerial platforms which are EE rated, and may not appear on all units.</p>

Labels and Nameplates - Models 3220, 3226 & 46xx

Left Side (Continued)

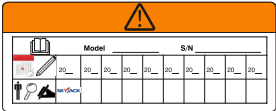

No.	Label Pictorial	Description
6		<p>Keep Clear</p> <p>Keep clear. Stay away from aerial platform when in operation.</p>
7		<p>Crushing Hazard</p> <p>Danger - Crushing hazard</p>
8		<p>Model Number*</p> <p>Product Identifier *Model number will vary, may not be as shown.</p>
9		<p>Annual Inspection</p> <p>Ensure that work platform has received annual inspection prior to operation.</p>
10		<p>Motor Controller</p> <p>Indicates motor controller aerial platform.</p>

Labels and Nameplates - Models 3220, 3226 & 46xx

Left Side (Continued)

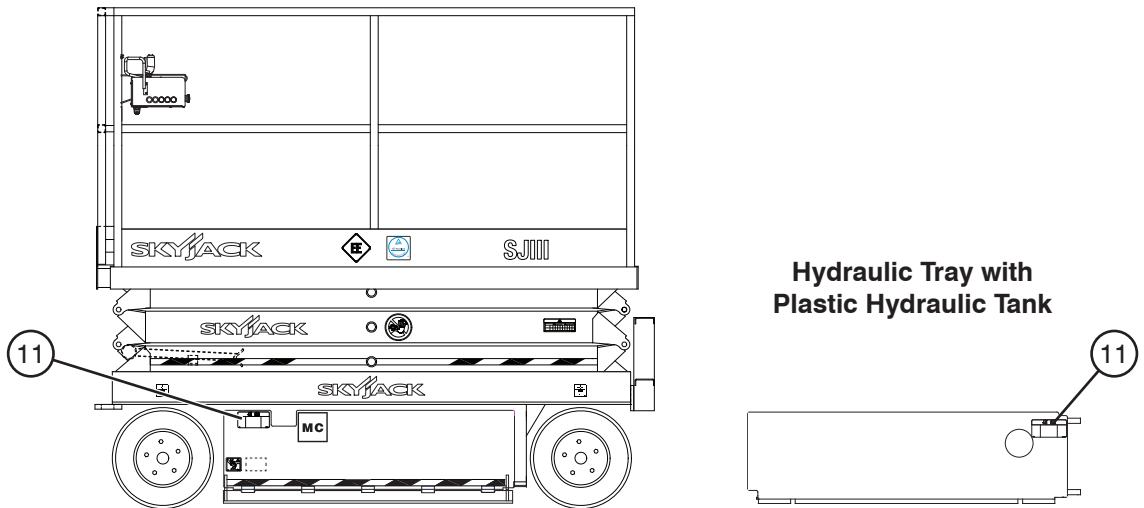

No.	Label Pictorial	Description
	<p style="text-align: center;">SJIII 32xx</p>	<p>Emergency Lowering Procedure Refer to Operating manual.</p> <ol style="list-style-type: none"> 1. Turn main power disconnect switch to off position. 2. To open lift cylinder holding valve located at the bottom of the cylinder: <ul style="list-style-type: none"> (A) push (B) turn knurled knob counterclockwise. 3. To lower the platform, pull out emergency lowering valve located on the outside of the hydraulic tray.
11	<p style="text-align: center;">SJIII 46xx</p>	<p>Emergency Lowering Procedure Refer to Operating manual.</p> <ol style="list-style-type: none"> 1. Turn main power disconnect switch to off position. 2. To open the lower lift cylinder holding valve located at the bottom of the cylinder: <ul style="list-style-type: none"> (A) push (B) turn knurled knob counterclockwise. To open the upper lift cylinder holding valve located at the bottom of the cylinder: If required, use emergency lowering rod located on the top of the base to: <ul style="list-style-type: none"> (A) push (B) turn knurled knob counterclockwise. 3. To lower the platform, pull out emergency lowering valve located on the outside of the hydraulic tray.

Labels and Nameplates - Models 3220, 3226 & 46xx

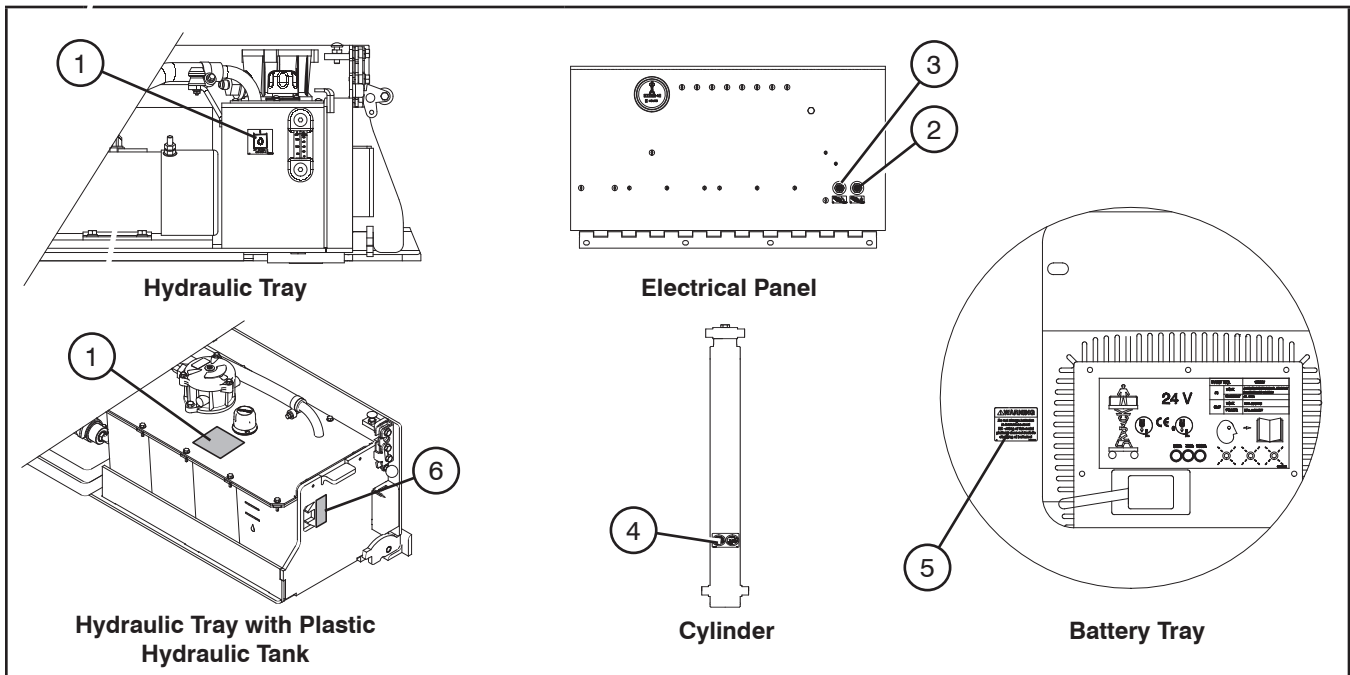

No.	Label Pictorial	Description
1		Hydraulic Oil ATF Dexron III Replace hydraulic fluid with ATF Dexron III only.
2		Ground Circuit Breaker Push to reset ground circuit breaker.
3		Power Circuit Breaker Push to reset power circuit breaker.
4		Orifice Installed Orifice installation warning
5		Warning - Connect Charger for EE Rated Aerial Platform (If Equipped) Do not charge batteries in hazardous area.
6		Hydraulic Oil Level

Labels and Nameplates - Models 3220, 3226 & 46xx

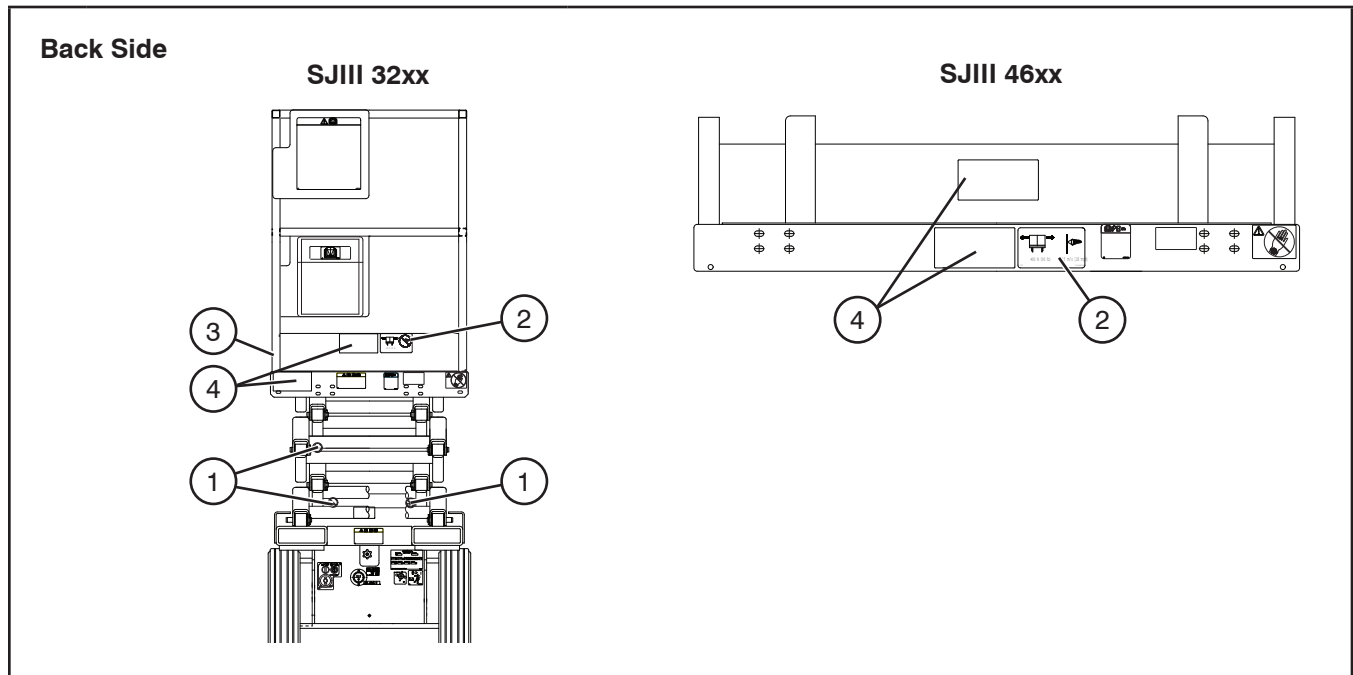

No.	Label Pictorial	Description
1		<p>Warning - Do Not Alter</p> <p>DO NOT alter or disable limit switches or other safety devices.</p>
2		<p>Horizontal Load Rating*</p> <p>Apply no more than the indicated side load. Operate below indicated wind speed only.</p> <p>*Horizontal load rating will vary, may not be as shown.</p>
3		<p>Fall Protection Anchorage</p> <p>Rated for one (1) person per anchorage.</p>
4		<p>Platform Capacity*</p> <p>Rated work load in each configuration</p> <p>*Platform capacity varies over different aerial platforms.</p>

Labels and Nameplates - Models 3220, 3226 & 46xx

Back Side (Continued)

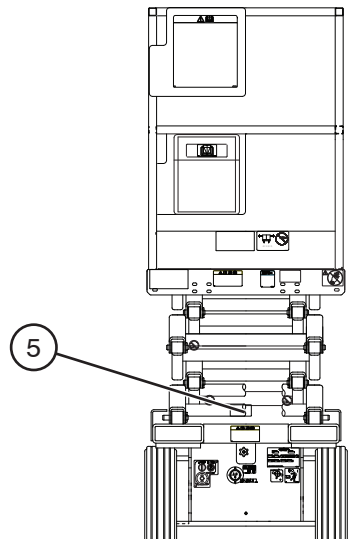

No.	Label Pictorial	Description
	<p style="text-align: center;">SJIII 32xx</p>	<p>Emergency Lowering Procedure Refer to Operating manual.</p> <ol style="list-style-type: none"> 1. Turn main power disconnect switch to off position. 2. To open lift cylinder holding valve located at the bottom of the cylinder: <ul style="list-style-type: none"> (A) push (B) turn knurled knob counterclockwise. 3. To lower the platform, pull out emergency lowering valve located on the outside of the hydraulic tray.
<p style="text-align: center;">5</p>	<p style="text-align: center;">SJIII 46xx</p>	<p>Emergency Lowering Procedure Refer to Operating manual.</p> <ol style="list-style-type: none"> 1. Turn main power disconnect switch to off position. 2. To open the lower lift cylinder holding valve located at the bottom of the cylinder: <ul style="list-style-type: none"> (A) push (B) turn knurled knob counterclockwise. To open the upper lift cylinder holding valve located at the bottom of the cylinder: If required, use emergency lowering rod located on the top of the base to: <ul style="list-style-type: none"> (A) push (B) turn knurled knob counterclockwise. 3. To lower the platform, pull out emergency lowering valve located on the outside of the hydraulic tray.

Labels and Nameplates - Models 3220, 3226 & 46xx

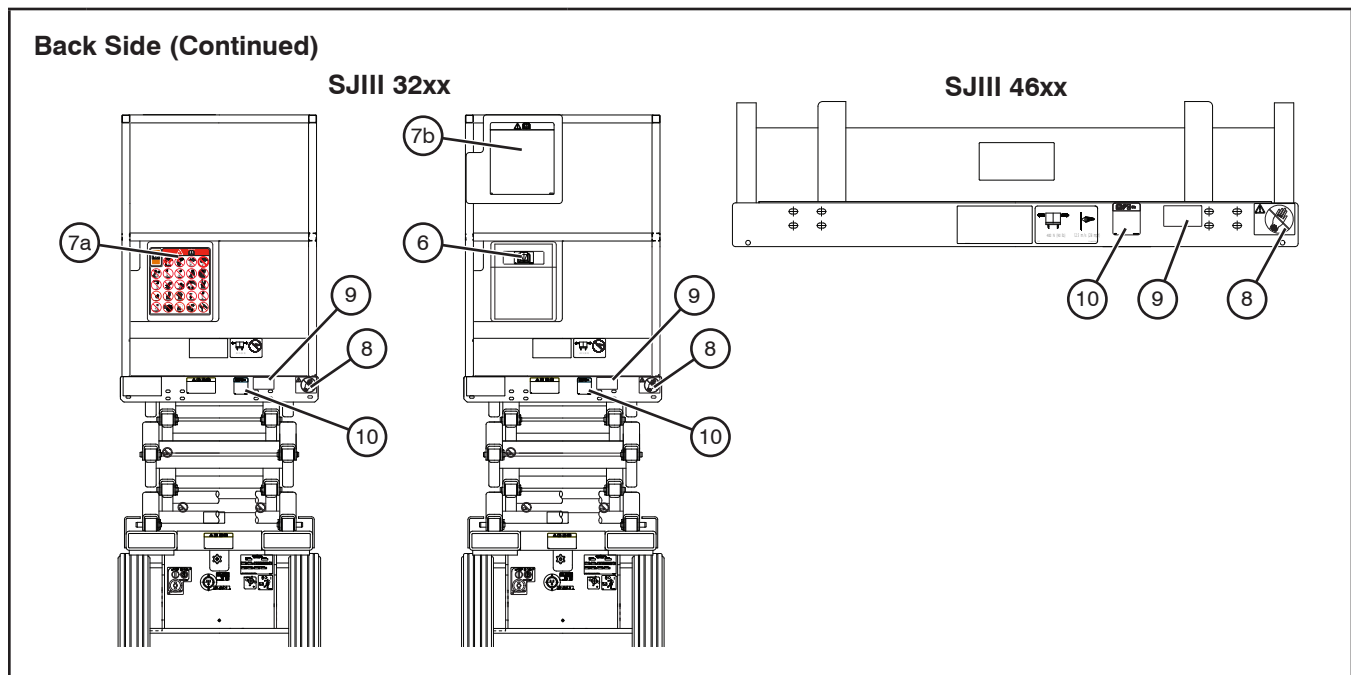

No.	Label Pictorial	Description
6		Manual Storage Box Indicates location of operating manual.
7a		Hazard Identification/Manual Storage Box Refer to Section 1: Safety Rules . Read and understand the outlined risks associated with this MEWP prior to operation. Indicates location of operating manual.
7b		Hazard Identification Refer to Section 1: Safety Rules . Read and understand the outlined risks associated with this work platform prior to operation.
8		No Jewelry Caution - Do not wear jewelry.
9		Warning - California Proposition 65 Cancer and Reproductive Harm- https://www.p65warnings.ca.gov/ .
10		Operator's Daily Inspection Refer to the Operating manual. Perform visual inspection and function tests at the beginning of each shift. Refer to Section 4: Maintenance and Inspection Schedule .

Labels and Nameplates - Models 3220, 3226 & 46xx

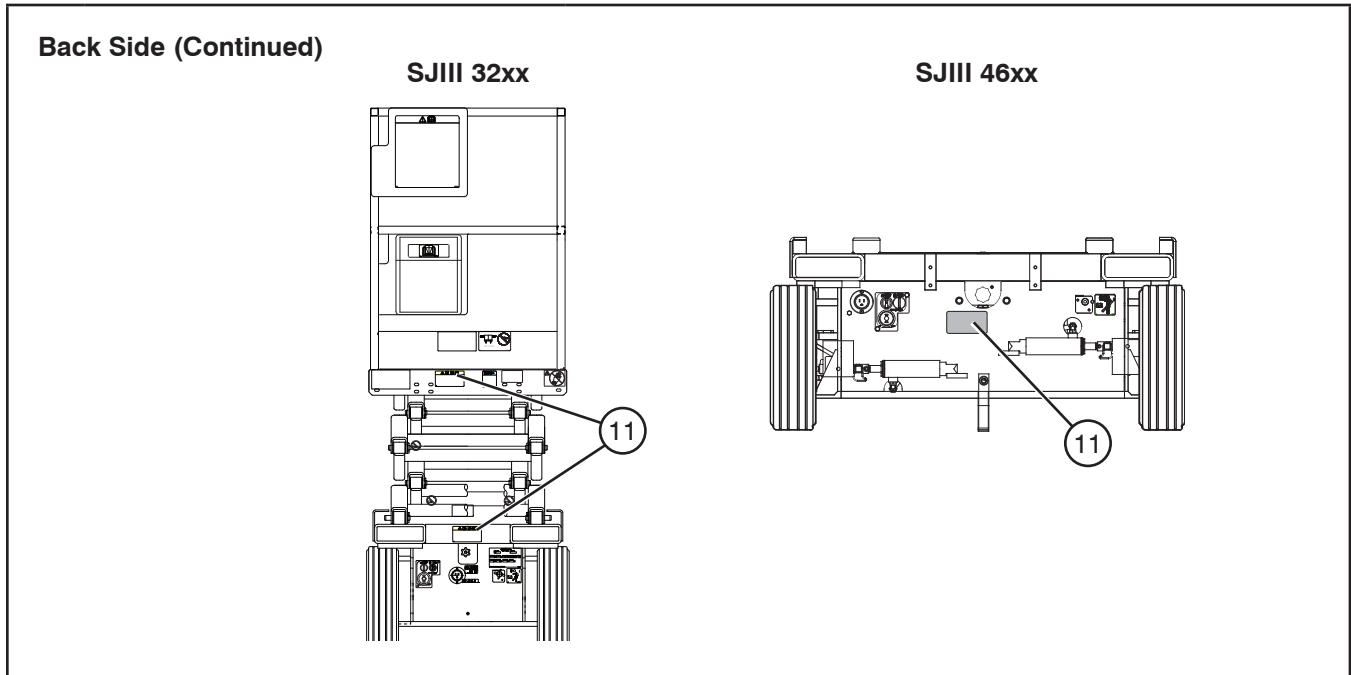

No.	Label Pictorial	Description
11		<p>Winching/Towing/Pushing Procedure Refer to Operating manual.</p> <ol style="list-style-type: none"> 1. Block or chock wheels to prevent aerial platform from rolling. 2. Turn main power disconnect switch to off position. 3. Locate pin brake cylinders. 4. Using a 3/4" (19mm) wrench, rotate the block on each brake pin 90 degrees. Brakes are now released. 5. Open free-wheeling valve by turning counterclockwise. 6. Push/tow/winches to desired location. 7. Block or chock wheels to prevent aerial platform from rolling. 8. Close free-wheeling valve by turning clockwise. 9. Using a 3/4" (19mm) wrench, rotate the block on each brake pin 90 degrees. Brakes are now engaged.

Labels and Nameplates - Models 3220, 3226 & 46xx

Back Side (Continued)

SJIII 46xx

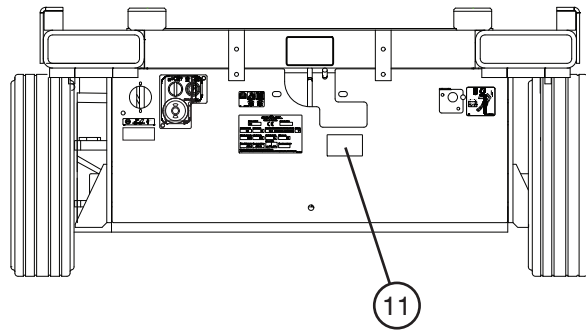

No.	Label Pictorial	Description
11		<p>Winching/Towing/Pushing Procedure Refer to Operating manual.</p> <ol style="list-style-type: none"> 1. Block or chock wheels to prevent aerial platform from rolling. 2. Turn main power disconnect switch to off position. 3. Locate brake valve and pump. 4. Push in black knob. 5. Pump by pushing red knob in and out until firm resistance is felt. Brake is now released. 6. Open free-wheeling valve by turning counterclockwise. 7. Push/tow/winch to desired location. 8. Block or chock wheels to prevent aerial platform from rolling. 9. Reset brake by pulling out black knob. 10. Close free-wheeling valve by turning clockwise.

Labels and Nameplates - Models 3220, 3226 & 46xx

Back Side (Continued)

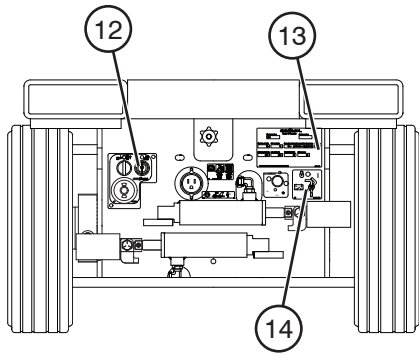

(SJIII 32xx)

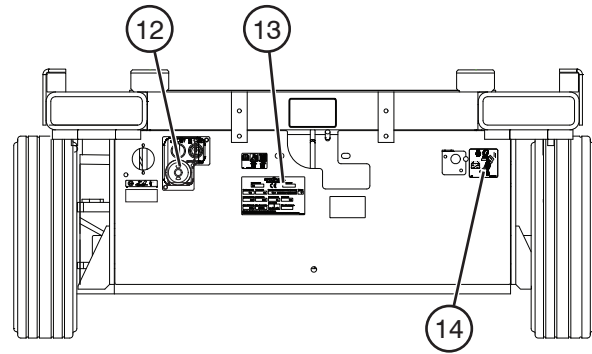

(SJIII 46xx)

No.	Label Pictorial	Description
12		<p>Base Controls</p> <p>Select “ ” to lower or “ ” raise platform.</p> <p>Select “ ” platform to enable platform controls, “ ” off to disable controls or “ ” base to enable base control console.</p> <p>Push “ ” to disable controls.</p>
13		<p>Serial Plate*</p> <p>Product identification and specifications *Serial plates will vary, may not be as shown.</p>
14		<p>Main Power Disconnect</p> <p>Rotate clockwise to turn on main power, rotate counterclockwise to turn off main power, insert padlock to lock in position.</p>

Labels and Nameplates - Models 3220, 3226 & 46xx

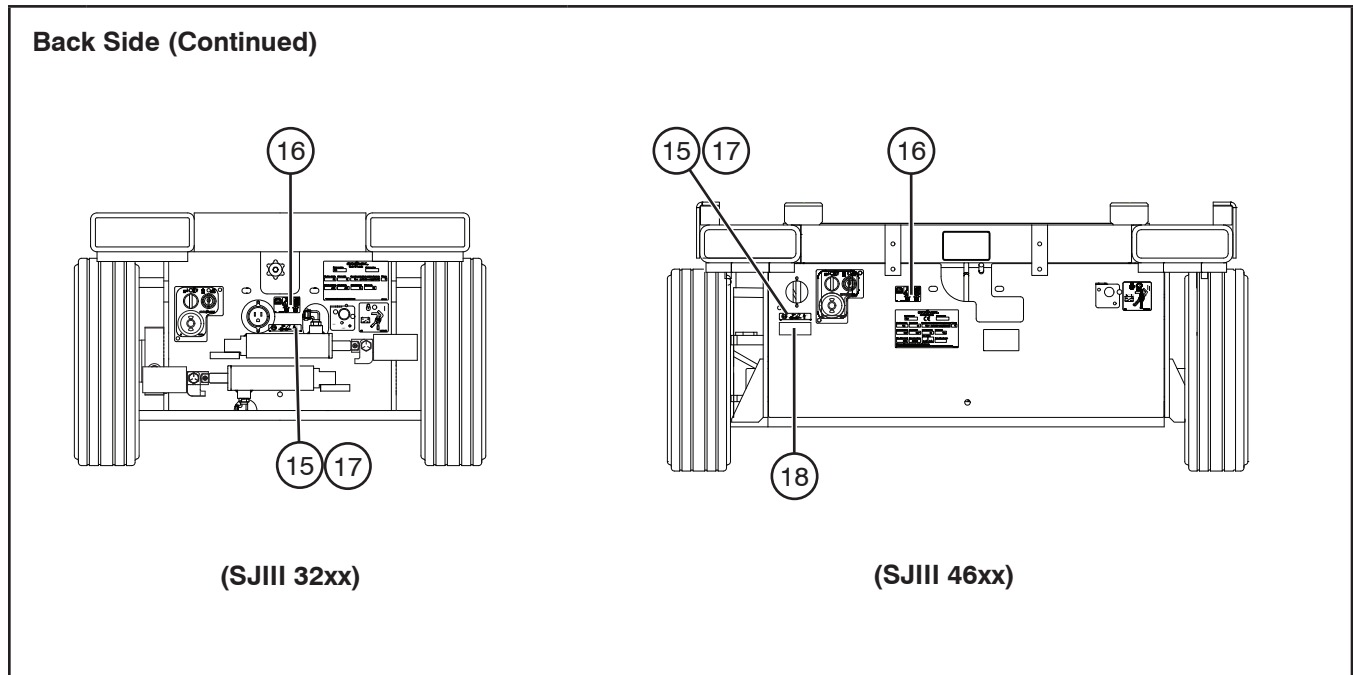

No.	Label Pictorial	Description
15		<p>Connect Platform AC Supply</p> <p>Connect AC power supply here for platform accessory outlet.</p>
16		<p>Refer to the Operating manual for Free-wheeling Procedure.</p> <p>Open free-wheeling valve by turning counterclockwise. Close free-wheeling valve by turning clockwise.</p>
17		<p>Connect Air Supply (If Equipped)</p> <p>Connect platform air supply here.</p>
18		<p>Warning - AC Power for EE Rated Aerial Platform (If Equipped)</p> <p>Do not use AC power in hazardous locations.</p>

Labels and Nameplates - Models 3220, 3226 & 46xx

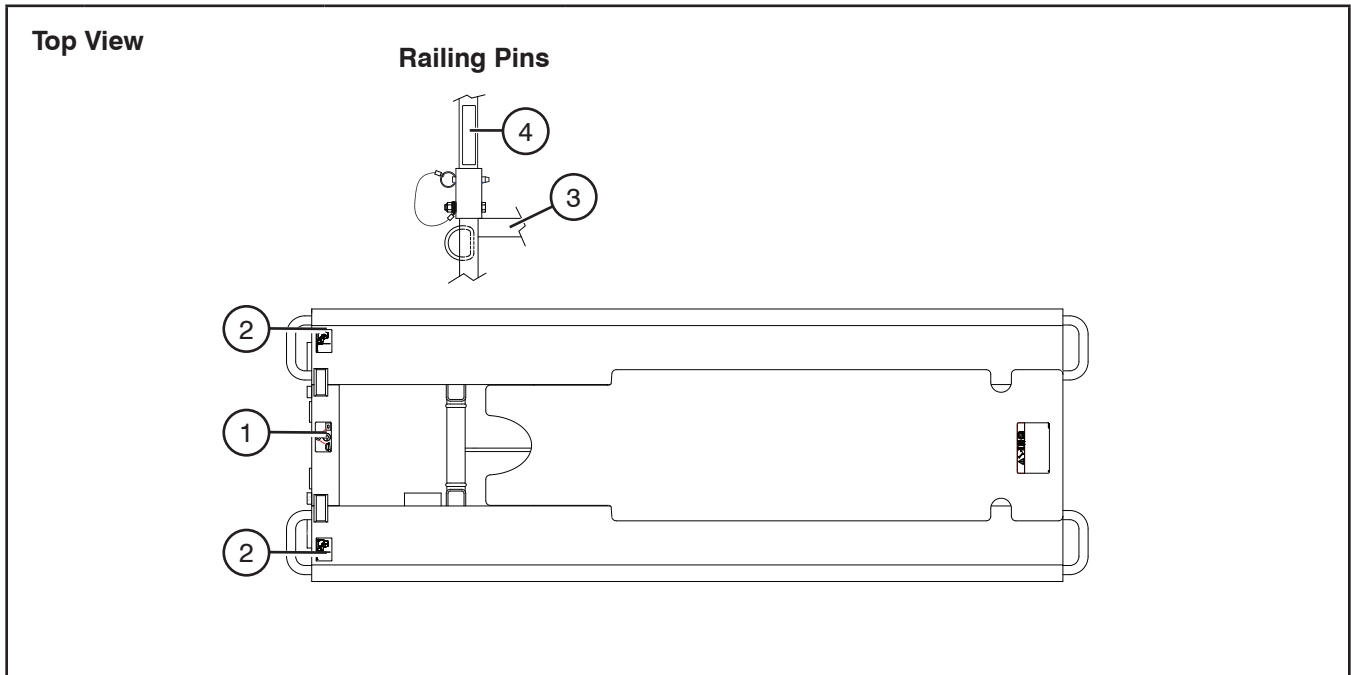

No.	Label Pictorial	Description
1		<p>Lift and Tie Down Points</p> <p>Only use these points for lifting or tying down.</p>
2		<p>Forklift Pocket</p> <p>Insert fork fully into pocket to lift aerial platform.</p>
3		<p>Falling Hazard - Railing Pins (Horizontal) (If Equipped)</p> <p>WARNING! Falling Hazard. Make sure hinged railing is pinned properly.</p>
4		<p>Falling Hazard - Railing Pins (Vertical) (If Equipped)</p> <p>WARNING! Falling Hazard. Make sure hinged railing is pinned properly.</p>

Labels and Nameplates - Models 3220, 3226 & 46xx

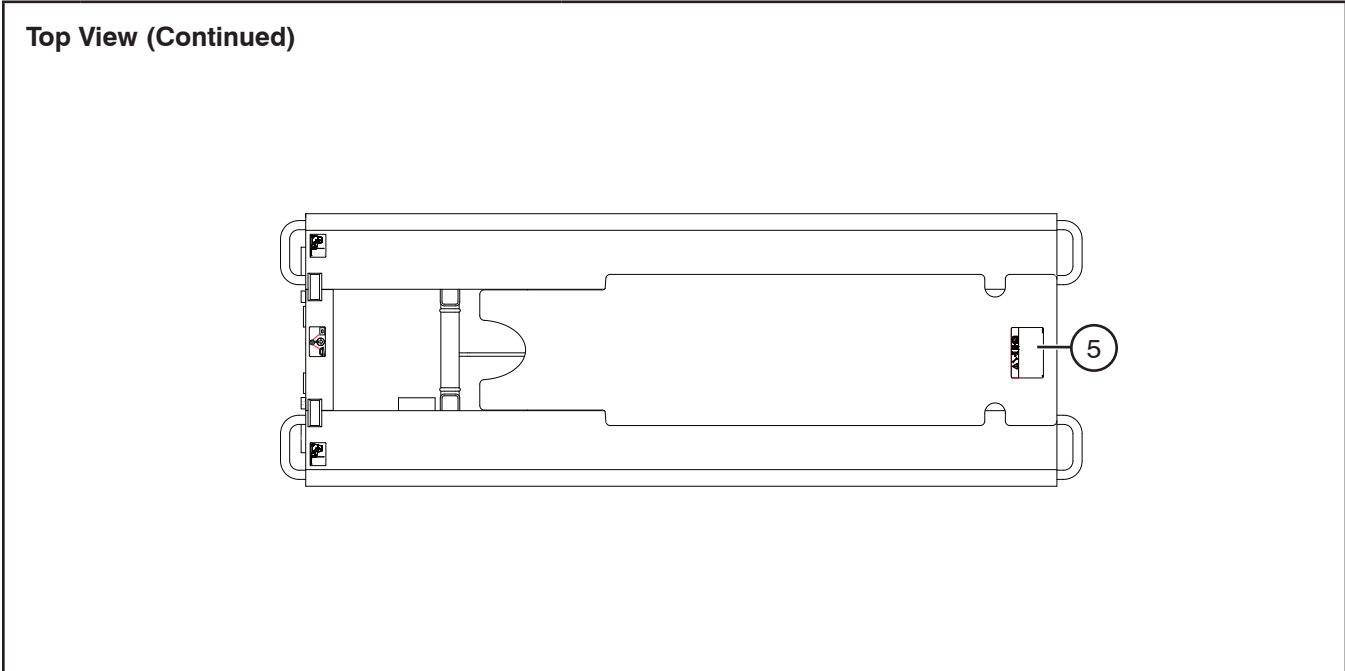

No.	Label Pictorial	Description
5		<p>How to engage maintenance support for inspection or maintenance. Refer to Operating manual.</p> <ol style="list-style-type: none"> 1. Raise platform until there is adequate clearance to swing down maintenance support. 2. Swing maintenance support down from storage bracket into a vertical position. Lower platform until the bottom end of maintenance support rests on the lower cross bar. 3. Maintenance support is now secured. (A) Turn main power disconnect switch to off position. (B) Perform inspection/maintenance. 4. Turn main power disconnect switch to on position. 5. Raise platform until there is adequate clearance to swing up maintenance support. 6. Swing maintenance support up and place into storage bracket. 7. Ensure platform is fully lowered.

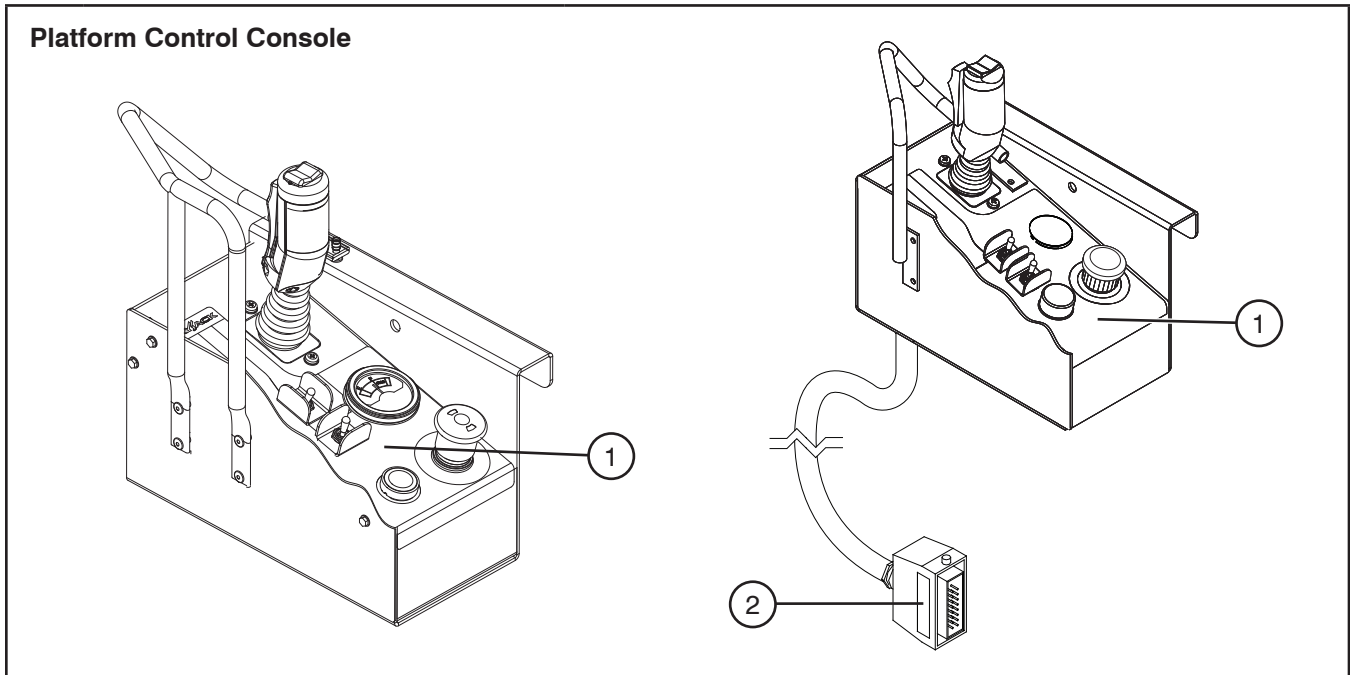

Labels and Nameplates - Models 3220, 3226 & 46xx

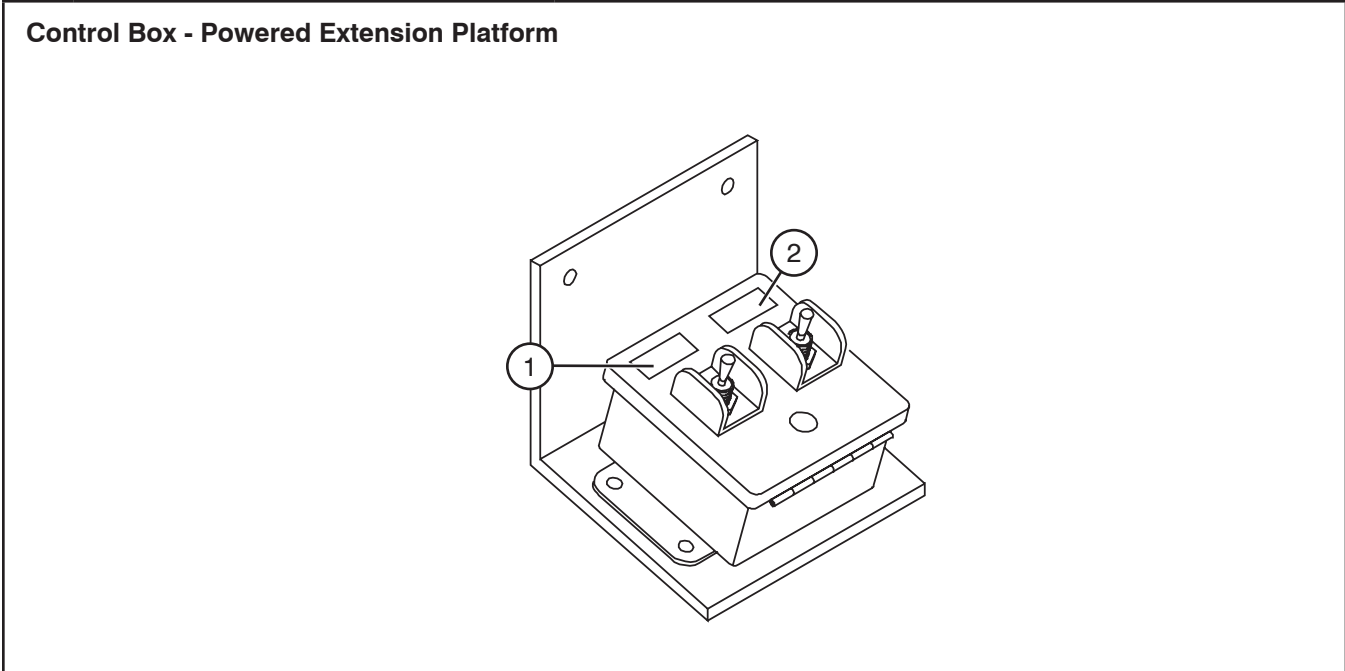

No.	Label Pictorial	Description
1		<p>Platform Controls</p> <p>Squeeze “” trigger to enable controller.</p> <p>Operate “” rocker switch to steer.</p> <p>Move controller handle forward to “” raise or backward to “” lower platform.</p> <p>Move controller handle “” forward to drive forward, or “” backward to drive reverse.</p> <p>Select “” inclined drive (low speed/high torque) or “” level drive (high speed/low torque) mode.</p> <p>Select “” lift, “” off or “” drive mode.</p> <p>Push “” to sound horn.</p> <p>Push “” emergency stop button to disable controls.</p> <p>Read “” operating manual.</p>
2	<p>Hydraulic proportional 3215/19</p>	<p>Hydraulic Proportional (If Equipped)</p> <p>Control box is suitable for use on hydraulic proportional aerial platforms.</p>

Labels and Nameplates - Models 3220, 3226 & 46xx



No.	Label Pictorial	Description
1		<p>Lift Enable (If Equipped)</p> <p>Select to enable lift mode.</p>
2		<p>Powered Extension Platform Extend/Retract (If Equipped)</p> <p>Select “” to extend or “” retract powered extension platform.</p>

6.0 Skyjack Features

Your Skyjack machine may be equipped with the following features:

ACCESSORYZERS™

Having equipment with features and functionality that allow you and your customers to do more is a vital part of the utilization equation. Skyjack offers a range of accessory products to further expand a given products adaptability and your power to offer a truly flexible rental choice.



WARNING

Cancer and Reproductive Harm-
<https://www.p65warnings.ca.gov/>

SKYJACK[™]

www.skyjack.com