

# S4726E/S4732E

## ELECTRIC SLAB SCISSOR LIFTS



- Self-propelled electric scissor lifts
- Compact & robust
- Roll-out extension decks for extra reach
- Suitable for indoor and outdoor use
- Ideal for construction & maintenance applications

**snorkel**  
[www.snorkellifts.com](http://www.snorkellifts.com)

# ELECTRIC SLAB SCISSOR LIFTS

# S4726E/S4732E

DIMENSIONS	S4726E	S4732E
Max. working height	9.9m	11.8m
Max. platform height (A)	7.9m	9.8m
Platform size (stowed)	2.14m x 1.05m	2.14m x 1.05m
Platform size (extended)	3.4m x 1.05m	3.4m x 1.05m
Extension deck length (B)	1.21m	1.21m
Overall length (with step) (D)	2.3m	2.3m
Overall length (without step)	2.26m	2.26m
Overall width (C)	1.19m	1.19m
Stowed height (E)	2.3m	2.39m
Min. height (guardrails folded)	1.85m	1.94m
Ground clearance (stowed)	76mm	76mm
Ground clearance (elevated)	19mm	19mm

PERFORMANCE	S4726E	S4732E
Platform capacity	454kg	350kg
Max. drive height	7.9m	9.8m
Max. wind speed	12.5m/s	12.5m/s
Max. drive speed (elevated)	3.2km/h	3.2km/h
Max. drive speed (stowed)	0.6km/h	0.6km/h
Raise/lower time	40/50 sec	50/60 sec
Gradeability	25%	25%
Inside turning radius	0.25m	0.25m
Outside turning radius	2.31m	2.31m
Tyres	15 x 5 non-marking rubber	15 x 5 non-marking rubber
Controls	proportional	proportional
Drive system	2 wheel drive	2 wheel drive

POWER	S4726E	S4732E
Power source	24V DC battery electric	
Charger	90-240V, 25amp	

WEIGHT	S4726E	S4732E
Weight	1,993kg	2,630kg

## TURNING RADIUS

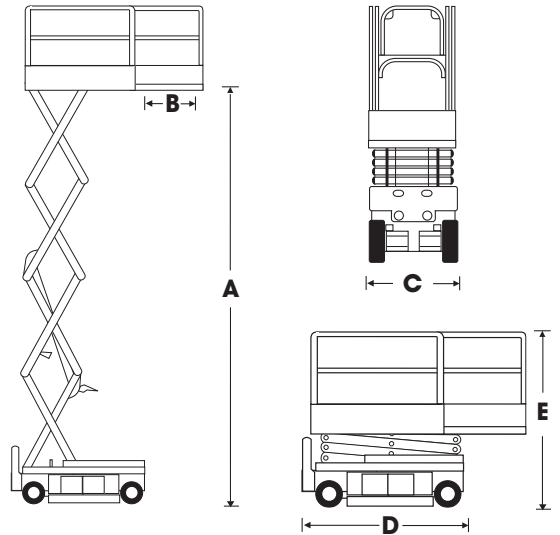
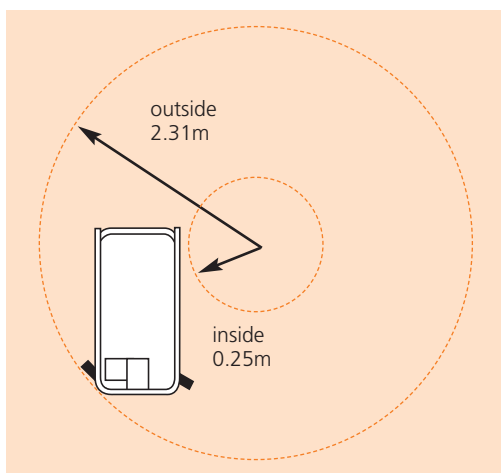

## STANDARD FEATURES

- Roll-out deck extension with dual locks
- Non-marking tyres
- Loading control pendant
- Swing-out service trays
- Saloon-door style entry gates
- Descent alarm
- Motion alarm
- Key switch
- 2 persons + equipment capacity indoor
- 1 person + equipment capacity outdoor
- Proportional controls, including descent
- Power line to platform
- Hour meter & onboard diagnostics display
- Integrated battery charger
- Battery condition indicator
- Crane & forklift points
- Dual lanyard attachments points
- Flashing amber light
- 2 year parts & labour, 5 year structural warranty
- CE approved

## OPTIONS

- Special paint colours
- Scissor stack roller slide plates (set of 2)
- Airline to platform
- Aircraft bumpguard package
- Panel carrier
- Environmental (green) oil

**snorkel** [www.snorkellifts.com](http://www.snorkellifts.com)

Vigo Centre, Birtley Road,  
Washington, Tyne & Wear,  
NE38 9DA, U.K.

t: +44 (0) 845 1550 057  
e: sales@snorkellifts.com