



MODELS | SJ 61T SJ 66T



## T SERIES Telescopic BOOM LIFTS

Skyjack continues to expand its product base by adding the new SJ 61T and SJ 66T to the SJ 40T and SJ 45T boom lifts. Built and designed using Skyjack's robust and reliable design philosophies, the new SJ 61T and SJ 66T boom lifts continue to offer the lowest life cycle costs, proven reliability, and ease of serviceability.

Superior terrainability is obtained utilizing Skyjack's exclusive axle based 4WD system which features a "Detroit Locker" type rear differential and limited slip front differential. Other competitive advantages include an innovative and intuitive direction sensing drive and

steer control system as well as a 45 degree steering angle which results in the industry's tightest turning radius. Skyjack's standard color coded and numbered wiring system, along with proven relay based controls, complete a well rounded package of superior, proven, operating characteristics.



# T SERIES

## Telescopic Boom Lifts

Specifications	SJ 61T	SJ 66T
Work Height	67' 3" (20.5 m)	72' (21.9 m)
Platform Height	61' 3" (18.7 m)	66' (20.1 m)
Horizontal Reach	51' 3" (15.6 m)	57' (17.4 m)
Platform Size	36" x 96" (0.9 x 2.4 m)	36" x 96" (0.9 x 2.4 m)
Stowed Width	96" (2.4 m)	96" (2.4 m)
Tailswing	47" (1.2 m)	47" (1.2 m)
Stowed Height	101" (2.6 m)	101" (2.6 m)
Stowed Length	30' 4" (9.2 m)	33' 11" (10.3 m)
Wheelbase	96" (2.4 m)	96" (2.4 m)
Ground Clearance	16" (0.4 m)	16" (0.4 m)
Platform Rotation	170°	180°
Jib Length	-	5' (1.5 m)
Jib Range +/-	-	63° / 66°
Weight	23,800 lbs (10,795 kg)	27,300 lbs (12,383 kg)
Gradeability - 4WD	50%	50%
Turning Radius (Inside) - 4WD	111" (2.8 m)	111" (2.8 m)
Turning Radius (Outside) - 4WD	199" (5.1 m)	199" (5.1 m)
Axle Oscillation	10" (0.3 m)	10" (0.3 m)
Drive Speed (stowed)	4.5 mph (7.2 km/h)	4.5 mph (7.2 km/h)
Drive Speed (raised)	0.5 mph (0.8 km/h)	0.5 mph (0.8 km/h)
Capacity	500 lbs (227 kg)	500 lbs (227 kg)
Maximum # of Persons	2	2

### STANDARD FEATURES

- Drivable at full height
- Axle based 4WD
- "Detroit Locker" type rear differential and limited slip front differential
- Oscillating axle
- Wet disc SAHR brakes (front and rear axle)
- 65hp Deutz diesel engine
- Swing out engine tray
- Swing up fiberglass cowlings
- 360° continuous turret rotation
- Direction sensing drive and steer controls
- Proportional controls
- Relay based control system
- Color coded and numbered wiring system
- 50% gradeability
- 15 x 19.5 grip lug air-filled tires
- 110V AC outlet on platform with GFI
- Tilt alarm with drive cut-out
- All motion alarm
- Operator horn
- Modular platform railing system
- Spring hinged gate
- Lanyard attachment points
- Tie down/lifting lugs

### OPTIONS†

- 3500W generator (Includes hydraulic oil cooler)
- Welder ready package (Includes 12 kW generator, hydraulic oil cooler, 3-phase power connection in platform, and welder mount)
- Welder package (Includes 12 kW generator, hydraulic oil cooler, 3-phase power connection in platform, welder mount, and Lincoln V275-S welder)
- Cold weather start kit
- Diesel scrubber
- Hydraulic oil cooler
- Flashing light
- Platform work lights
- 1/2" airline to platform
- 2WD
- 82hp GM Dual Fuel Engine
- Glazier kit
- Grip lug foam-filled tires
- Air-filled tires with tire sealant
- High flotation air-filled tires

† Capacities, and machine weights may differ when options are added

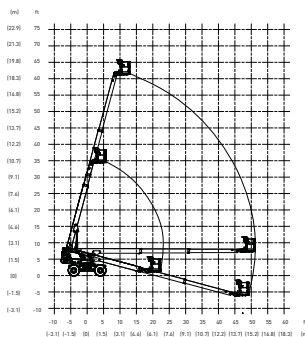

SJ 61T REACH DIAGRAM

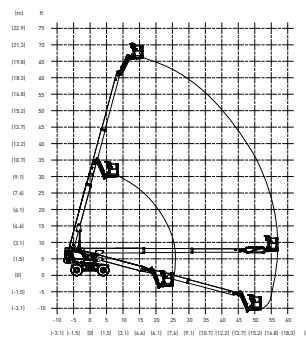

SJ 66T REACH DIAGRAM

### Skyjack Head Office

55 Campbell Rd. Guelph, ON Canada N1H 1B9  
 Sales Inquiries: 1-877-755-4387 (1-877-SJLIFTS)  
 Main Switchboard: 1-800-265-2738  
 Phone: 519-837-0888  
 Fax: 519-837-8104  
 Email: skyjack@skyjack.com

www.skyjack.com

This brochure is for illustrative purpose only and based on the latest information at the time of printing. Skyjack Inc. reserves the right to make changes at any time, without notice, to specifications, standard and optional equipment. Consult the Operating Maintenance and Parts Manuals for proper procedures. Work platforms have been tested to comply with ANSI and CSA standards as interpreted by Skyjack, Inc.

