



# SJ46 AJ

## ARTICULATING BOOM

### STANDARD FEATURES

- Axle based 4WD system
- Operator controlled locking rear differential and limited slip front differential
- Oscillating axle
- Drivable at full height
- 355° Non-continuous turret rotation
- 45% Gradeability
- Deutz D2.9L4 diesel engine or Kubota WG2503 dual fuel engine
- Swing out engine tray
- Swing up cowlings
- Modular platform railing system
- Dual-entry sliding mid rails
- 110V AC Outlet on platform with GFI
- EASYDRIVE™ direction sensing drive and steer controls
- SKYRISER™ true vertical rise
- Proportional controls
- Relay based control system
- SKYCODED™ color coded and numbered wiring system
- Hourmeter
- Operator horn
- All motion alarm
- Tie down/lifting lugs
- Wet disc SAHR brakes (rear axle)
- 12 x 16.5 Grip lug air-filled tires
- Telematics ready
- 2 Year Gold Leaf Warranty (5 year structural warranty)

### ACCESSORIES AND OPTIONS

- 30 x 60" Platform
- Perkins 404F-E22T diesel engine
- 3.5 kW Generator (Includes hydraulic oil cooler)
- Welder ready package (Includes 12 kW generator, hydraulic oil cooler, 3-phase power connection in platform, and welder mount)
- Welder package (Includes 12 kW generator, hydraulic oil cooler, 3-phase power connection in platform, welder mount, and Lincoln V275-S welder)
- Cold weather start kit (Recommended for regions where average monthly low temperatures can reach 14°F / -10°C (Includes cold start engine oil, battery blanket, hydraulic tank heater, and engine load kit (Deutz D2.9L4))
- Arctic weather package (Recommended for regions where average monthly low temperatures can reach -0.4°F / -18°C (Includes arctic engine oil, battery blanket, hydraulic tank heater, engine load kit (Deutz D2.9L4), block heater, arctic hydraulic oil, arctic platform rotator and arctic gear oil in the axles and swing drive glow plugs, arctic hydraulic hoses (all), and oversized foot switch cover are also included (standard equipment).)
- Hydraulic oil cooler
- Side gate
- Flashing light
- 1/2" Airline to platform
- Positive air shut-off valve
- Non destructive testing
- Glazier kit
- Pipe rack
- Platform work lights
- Tool caddy
- Control box cover
- Bio oil
- Secondary guarding (electrical or mechanical)
- Control box cover
- Auxiliary top rail (30 x 72" platform only)
- ELEVATE telematics
- Warranty options (3 year or 5 year plans available)

### TIRE OPTIONS

- Grip lug air-filled non-marking tires
- Grip lug foam-filled non marking tires
- Grip lug foam-filled tires
- High flotation air-filled tires

† Standard lead times may be increased when optional equipment is added, consult factory.  
‡ Capacities and machine weights may differ when options are added.

# SJ46 AJ ARTICULATING BOOM

Dimensions	SJ46 AJ
Work Height	52'3" (15.93 m)
Platform Height	46'3" (14.10 m)
Horizontal Reach	24'9" (7.54 m)
Up and Over Height	24'5" (7.45 m)
<b>A</b> Platform Size	30" x 72" (0.76 x 1.83 m)
<b>B</b> Stowed Width	90" (2.29 m)
<b>C</b> Tailswing	Zero
<b>D</b> Stowed Height	82" (2.06 m)
<b>E</b> Stowed Length	20' 10" (6.35 m)
<b>F</b> Wheelbase	80" (2.03 m)
<b>G</b> Ground Clearance	16" (0.39 m)

Specifications	SJ46 AJ
Rotation	355° NC
Platform Rotation	170°
Jib Length	5' (1.52 m)
Jib Range +/-	+70° / -75°
Weight	13,300 lbs (6,033 kg)
Gradeability	45%
Turning Radius (Inside)	98" (2.49 m)
Turning Radius (Outside)	178" (4.52 m)
Axle Oscillation	5" (12.70 cm)
Drive Speed (High speed)	4.8 mph (7.7 km/h)
Capacity	500 lbs (227 kg)
Local Floor Load ( With Rated Load)	115 psi (793 kPa)
Overall Floor Load (With Rated Load)	200 psf (9.58 kPa)
Maximum # of Persons	2
Tire Type	Air Filled
Tire Size	12 x 16.5
Diesel Engine	48 HP
Dual Fuel Engine	61 HP
Fuel Tank Capacity	17 gallon (64 L)
Hydraulic Reservoir	24 gallon (91 L)

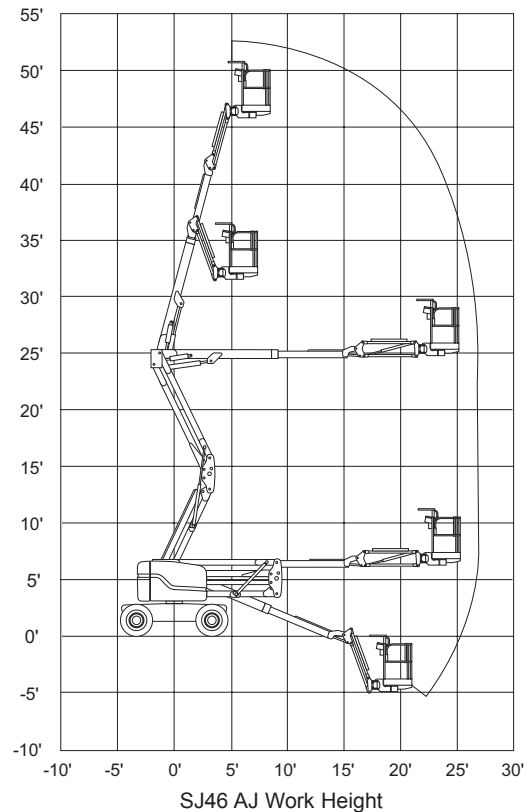
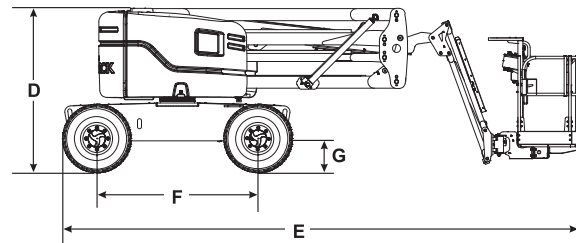
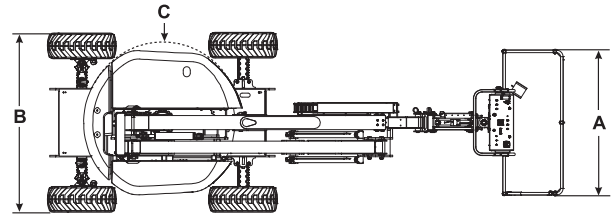

## Skyjack Head Office

55 Campbell Rd. Guelph, ON Canada N1H 1B9  
 Sales Inquiries: 1-877-755-4387 (1-877-SJLIFTS)  
 Main Switchboard: 1-800-265-2738  
 Phone: 519-837-0888  
 Fax: 519-837-8104  
 Email: skyjack@skyjack.com  
 www.skyjack.com

This brochure is for illustrative purpose only and based on the latest information at the time of printing. Skyjack Inc. reserves the right to make changes at any time, without notice, to specifications, standard and optional equipment. Consult the Operating Maintenance and Parts Manuals for proper procedures. Work platforms have been tested to comply with ANSI and CSA standards as interpreted by Skyjack Inc.

