

SELF-PROPELLED SCISSOR LIFTS OPERATOR'S MANUAL

with Maintenance Information and Parts List

(For JCPT0607DCS)



WARNING

THE MANUFACTURER SHALL NOT BE HELD LIABLE IN CASE OF FAULTS OR ACCIDENTS DUE TO NEGLIGENCE, INCAPACITY, INSTALLATION BY UNQUALIFIED TECHNICIANS AND IMPROPER USE OF THE MACHINE

DO NOT OPERATE THIS MACHINE UNTIL YOU READ AND UNDERSTAND ALL THE DANGERS, WARNINGS AND CAUTIONS IN THIS MANUAL

Part Number: SM0115111



Zhejiang Dingli Machinery Co., Ltd.

First Edition, November 2015 Printing

Version of the Record

Version of the Record

Version Number

Create Date

SM0115111_Rev1.0 2015-11

Important

Read, understand and obey these safety rules and operating instructions before operating this machine.

Only trained and authorized personnel shall be permitted to operate this machine. This manual should be considered a permanent part of your machine and should remain with the machine at all times. If you have any questions, please call DINGLI Machinery.

Contents

	Page
Safety Rules	1
Legend	7
Decals	8
Specifications	11
Control panel	12
Pre-Operating Instructions	15
Workplace Inspection	17
Function Tests	18
Operating Instructions	22
Transport and Lifting Instructions	33
Maintenance	35
Schematic	55
Inspection and Repair Log	57

Owners, Users and operators:

We appreciate your choice of our machine for your application. Our number one priority is user safety, which is best achieved by our joint efforts. We feel that you make a major contribution to safety if you, as the equipment users and operators:

- 1 Comply with employer, job site and governmental rules.
- 2 Read, understand and follow the instructions in this and other manuals supplied with this machine.
- 3 Use good safe work practices in a commonsense way.
- 4 Only have trained / certified operators, directed by informed and knowledgeable supervision, running the machine.

If there is anything in this manual that is not clear or which you believe should be added, please contact us.

Contact us:

Zhejiang Dingli Machinery Co., Ltd.

1255 Baiyun South Road. Leidian Town.
Deqing Zhejiang

China

Tel: +86-572-8681688

Fax: +86-572-8681690

Web: www.cndingli.com

E-mail: market@cndingli.com

Safety Rules**Danger**

Failure to obey the instructions and safety rules in this manual will result in death or serious injury.

Do Not Operate Unless:

- You learn and practice the principles of safe machine operation contained in this operator's manual.
 - 1 Avoid hazardous situations.**
 - Know and understand the safety rules before going on to the next section.**
 - 2 Always perform a pre-operation inspection.
 - 3 Always perform function tests prior to use.
 - 4 Inspect the workplace.
 - 5 Only use the machine as it was intended.
- You read, understand and obey the manufacturer's instructions and safety rules— safety and operator's manuals and machine decals.
- You read, understand and obey employer's safety rules and worksite regulations.
- You read, understand and obey all applicable governmental regulations.
- You are properly trained to safely operate the machine.

Decal Legend

DINGLI product decals use symbols, color coding and signal words to identify the following:



▲ Safety alert symbol—used to alert personnel to potential personal injury hazards. Obey all safety messages that follow this symbol to avoid possible injury or death.

▲ DANGER Red—used to indicate the presence of an imminently hazardous situation which, if not avoided, will result in death or serious injury.

▲ WARNING Orange—used to indicate the presence of a potentially hazardous situation which, if not avoided, could result in death or serious injury.

▲ CAUTION Yellow with safety alert symbol- used to indicate the presence of a potentially hazardous situation which, if not avoided, may cause minor or moderate injury.

NOTICE Blue without safety alert symbol- used to indicate the presence of a potentially hazardous situation which, if not avoided, may result in property damage.

Safety Rules

Intended Use

This machine is intended to be used only to lift personnel, along with their tools and materials to an aerial work site.

Safety Sign Maintenance

Replace any missing or damaged safety signs. Keep operator safety in mind at all times. Use mild soap and water to clean safety signs. Do not use solvent-based cleaners because they may damage the safety sign material.

⚠️ Electrocutation Hazard

This machine is not electrically insulated and will not provide protection from contact with or proximity to electrical current.



Maintain safe distances from electrical power lines and apparatus in accordance with applicable governmental regulations and the following chart.

Voltage Phase to Phase	Minimum Safe Approach Distance
0 to 300V	Avoid Contact
300V to 50kV	3.05m
50kV to 200kV	4.60m
200kV to 350kV	6.10m
350kV to 500kV	7.62m
500kV to 750kV	10.67m
750kV to 1000kV	13.72m

Allow for platform movement, electrical line sway or sag and beware of strong or gusty winds.

Keep away from the machine if it contacts energized power lines. Personnel on the ground or in the platform must not touch or operate the machine until energized power lines are shut off.

Do not operate the machine during lightning or storms.

Do not use the machine as a ground for welding.

⚠️ Tip-over Hazard

Occupants, equipment and materials must not exceed the maximum platform capacity or the maximum capacity of the platform extension.

Maximum capacity – JCPT0607DCS

Maximum occupants (Indoor use)	2
Maximum occupants (Outdoor use)	1
Platform allowable maximum load	240 kg
Extension deck allowable maximum load	100kg

Work Area Safety

Do not raise the platform unless the machine is on a firm, level surface.

Do not drive over 1.1 km/h with the platform raised.



Do not depend on the tilt alarm as a level indicator. The tilt alarm sounds on the chassis and in the platform when the machine is on a

Safety Rules

slope.

If the tilt alarm sounds:

Lower the platform. Move the machine to a firm, level surface. If the tilt alarm sounds when the platform is raised, use extreme caution to lower the platform.

For outdoor use machine, do not raise the platform when wind speeds may exceed 12.5 m/s. If wind speeds exceed 12.5 m/s when the platform is raised, lower the platform and do not continue to operate the machine.

Do not operate the machine in strong or gusty winds. Do not increase the surface area of the platform or the load. Increasing the area exposed to the wind will decrease machine stability.



Do not use the platform controls to free a platform that is caught, snagged or otherwise prevented from normal motion by an adjacent structure. All personnel must be removed from the platform before attempting to free the platform using the ground controls.

Use extreme care and slow speeds while driving the machine in the stowed position across uneven terrain, debris, unstable or slippery surfaces and near holes and drop-offs.

Do not drive the machine on or near uneven terrain, unstable surfaces or other hazardous conditions with the platform raised.

Do not push off or pull toward any object outside of the platform.



Maximum allowable manual force

Model	Application	manual force	Maximum occupants
JCPT0607DCS	Outdoor	200N	1
	Indoor	400N	2

Do not use the machine as a crane.

Do not place or attach fixed or overhanging loads to any part of this machine.

Do not push the machine or other objects with the platform.

Do not operate the machine with the chassis trays open.

Do not contact adjacent structures with the platform.

Do not alter or disable the limit switches.

Do not tie the platform to adjacent structures.

Do not place loads outside the platform perimeter.



Do not alter or disable machine components that in any way affect safety and stability.

Do not replace items critical to machine stability with items of different weight or specification.

Do not use batteries that weigh less than the original equipment. Batteries are used as counterweight and are critical to machine

Safety Rules

stability. Each battery must weigh 25 kg. The batteries must weigh a minimum of 50 kg.

Do not modify or alter an aerial work platform without prior written permission from the manufacturer. Mounting attachments for holding tools or other materials onto the platform, toe boards or guard rail system can increase the weight in the platform and the surface area of the platform or the load.

Do not place ladders or scaffolds in the platform or against any part of this machine.

Do not transport tools and materials unless they are evenly distributed and can be safely handled by person(s) in the platform.

Do not use the machine on a moving or mobile surface or vehicle.

Be sure all tires are in good condition and lug nuts are properly tightened.

▲ Crushing Hazard

Keep hands and limbs out of scissors.

Keep hands clear when folding rails.

Use common sense and planning when operating the machine with the controller from the ground. Maintain safe distances between the operator, the machine and fixed objects.

Maintain a firm grasp on the platform rail when removing the rail pins. Do not allow the platform guard rails to fall.

▲ Operation on Slopes Hazard

Do not drive the machine on a slope that exceeds the slope and side slope rating of the machine.

Slope rating applies to machines in the stowed position.



Maximum slope rating stowed

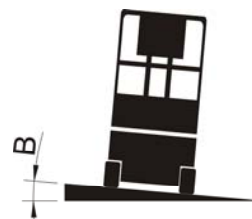

Maximum side slope rating stowed

Model	A	B
JCPT0607DCS	25% (14°)	25% (14°)

Note: Slope rating is subject to ground conditions and adequate traction.

▲ Fall Hazard

The guard rail system provides fall protection. During operation, occupants in the platform must wear a full body harness with a lanyard attached to an authorized lanyard anchorage point. Attach only one (1) lanyard per lanyard anchorage point.

Do not sit, stand or climb on the platform guard rails. Maintain a firm footing on the platform floor at all times.



Do not climb down from the platform when raised.

Keep the platform floor clear of debris.

Close the entry gate before operating.

Do not operate the machine unless the guard rails are properly installed and the entry is secured for operation.

Do not operate the machine the entry gate is secured for operation.

Safety Rules

▲ Collision Hazard

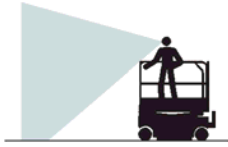

Be aware of limited sight distance and blind spots when driving or operating.

Be aware of extended platform position(s) when moving the machine.

Check the work area for overhead obstructions or other possible hazards.



Be aware of crushing hazards when grasping the platform guard rail.

Operators must comply with employer, job site and governmental rules regarding use of personal protective equipment.

Observe and use color-coded direction arrows on the platform controls and platform decal plate for drive and steer functions.

Do not operate a machine in the path of any crane or moving overhead machinery unless the controls of the crane have been locked out and/or precautions have been taken to prevent any potential collision.

No stunt driving or horseplay while operating a machine.

Do not lower the platform unless the area below is clear of personnel and obstructions.



Limit travel speed according to the condition of the ground surface, congestion, slope, location of personnel, and any other factors which may cause collision.

▲ Component Damage Hazard

Do not use any battery or charger greater than 24V.

Do not use the machine as a ground for welding.

▲ Explosion and Fire Hazard

Do not operate the machine in hazardous locations or locations where potentially flammable or explosive gases or particles may be present.

▲ Damaged Machine Hazard

Do not use a damaged or malfunctioning machine.

Conduct a thorough pre-operation inspection of the machine and test all functions before each work shift. Immediately tag and remove from service a damaged or malfunctioning machine.

Be sure all maintenance has been performed as specified in this manual

Be sure all decals are in place and legible.

Be sure the manuals are complete, legible and in the storage container located in the platform.

▲ Crushing Hazard

Keep hands and limbs out of scissors.

Use common sense and planning when operating the machine with the controller from the ground. Maintain safe distances between the operator, the machine and fixed objects.

Safety Rules

⚠ Bodily Injury Hazard

Do not operate the machine with a hydraulic oil or air leak. An air leak or hydraulic leak can penetrate and/or burn skin.

Improper contact with components under any cover will cause serious injury. Only trained maintenance personnel should access compartments. Access by the operator is only advised when performing a pre-operation inspection. All compartments must remain closed and secured during operation.

⚠ Battery Safety

⚠ Burn Hazard

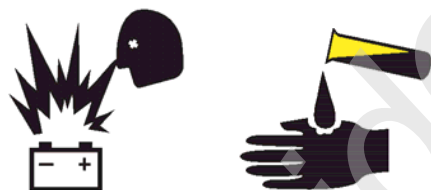

Batteries contain acid. Always wear protective clothing and eye wear when working with batteries.

Avoid spilling or contacting battery acid. Neutralize battery acid spills with baking soda and water.

⚠ Explosion Hazard

Keep sparks, flames and lighted tobacco away from batteries. Batteries emit explosive gas.

The battery tray should remain open during the entire charging cycle.



Do not contact the battery terminals or the cable clamps with tools that may cause sparks.

⚠ Component Damage Hazard

Do not use any battery charger greater than 24V to charge the batteries.

⚠ Electrocution/ Burn Hazard



Connect the battery charger to a grounded, AC 3-wire electrical outlet only.

Inspect daily for damaged cords, cables and wires.

Replace damaged items

before operating.

Avoid electrical shock from contact with battery terminals. Remove all rings, watches and other jewelry.

⚠ Tip-over Hazard

Do not use batteries that weigh less than the original equipment. Batteries are used as counterweight and are critical to machine stability. Each battery must weigh 25 kg. The batteries must weigh a minimum of 50 kg.

⚠ Lifting Hazard

Use the appropriate number of people and proper lifting techniques when lifting batteries.

Lockout after Each Use

- 1 Select a safe parking location - firm level surface, clear of obstruction and traffic.
- 2 Lower the platform.
- 3 Turn the key switch to the off position and remove the key to secure from unauthorized use.
- 4 Chock the wheels.
- 5 Charge the batteries.

Legend

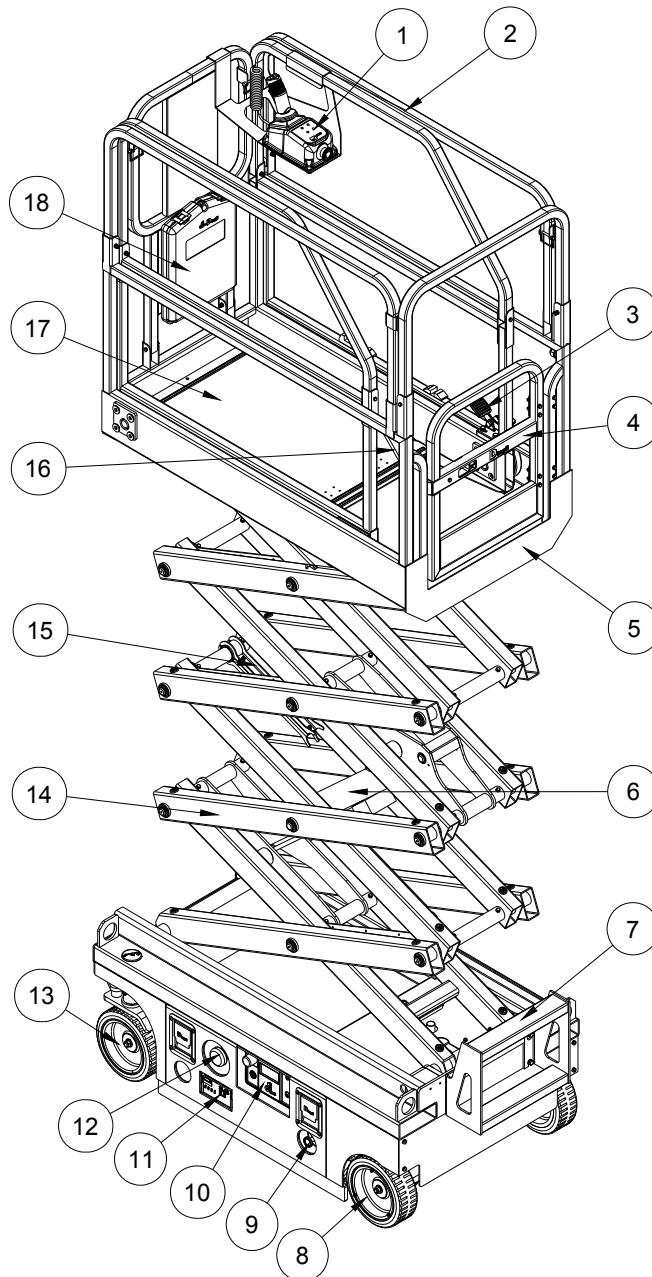

- | | | | |
|---|----------------------------------|----|--------------------------|
| 1 | Platform controller | 10 | Ground Control Panel |
| 2 | Platform guard rails | 11 | Batteries charger |
| 3 | Platform extension release pedal | 12 | Main power switch |
| 4 | Platform entry gate | 13 | Steer Wheels |
| 5 | Main Platform | 14 | Scissor |
| 6 | Lift Cylinder | 15 | Safety arms |
| 7 | Entry ladder | 16 | Lanyard anchorage point |
| 8 | Drive wheels | 17 | Platform extension |
| 9 | Emergency lowering knob | 18 | Manual storage container |

OPERATOR'S MANUAL *with Maintenance Information***Decals****Decal Inspection**

Use the pictures on the next page to verify that all decals are legible and in place.

Below is a numerical list with quantities and descriptions.

No.	Part No.	Description	Qty.	Remark
1	9414101	Danger – Safety rules	1	
2	9414103	Danger – Tip-over hazard	1	
3	9334011	Notice – Operator's manual storage	1	
4	9314013	Instructions – Refer the operator to the instructions for use	2	
5	9414123	Label – Lanyard anchorage	2	
6	9414069	Label – Capacity 240kg	1	
7	9414109	Caution – Max. manual force: 400N (Indoor) 200N (Outdoor)	2	
8	9614065	Cosmetic – JCPT0607DCS	2	
9	9514103	Cosmetic – Mark	1	
10	9514201	Cosmetic – CE	1	
11	9413013	Danger – Crushing hazard	1	
12	9514301	Cosmetic – IPAF	1	
13	9313011	Instructions – Safety arm	2	
14	9311011	Instructions – Forklift pockets	4	
15	9311027	Instructions – Wheel load: 450kg	4	
16	9311015	Instructions – Tie down point	4	
17	9311013	Instructions – Lift point	4	
18	9311017	Instructions – Emergency lower	1	
19	9311105	Notice – Main power switch operation	1	
20	9411011	Danger – Explosion / burn hazard	1	
21	9411013	Warning – Inspected and operation properly	1	
22	9211013	Decal – Manufacturer's plate	1	

Decals

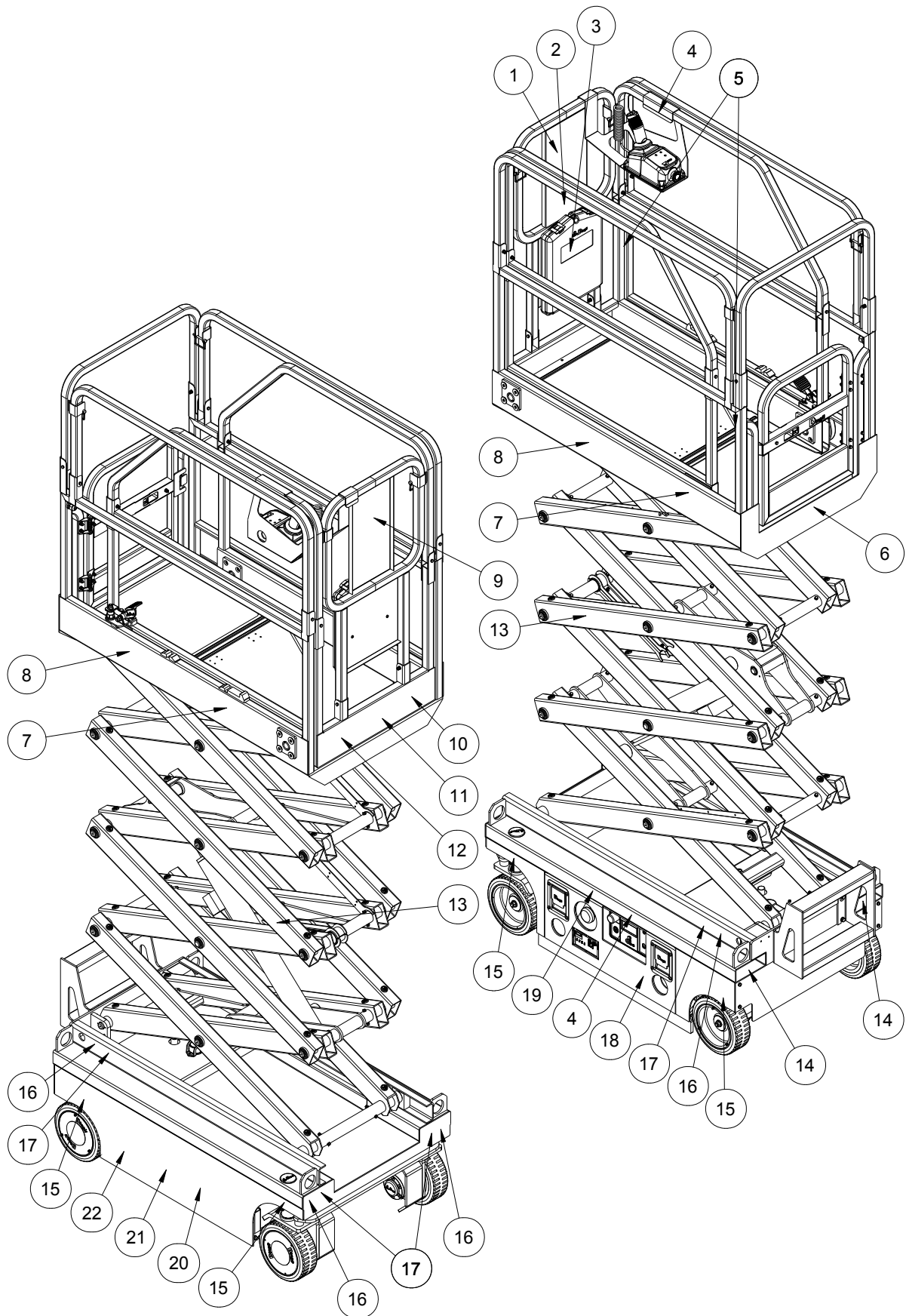

OPERATOR'S MANUAL with Maintenance Information

Decals

Platform

① 9414101

⚠ DANGER

Failure to read, understand and obey the operator's manual and the following safety rules will result in death or serious injury.

Improper Use Hazard

- Avoid hazardous situations.
- Always perform a pre-operation inspection.
- Always perform function tests prior to use.
- Inspect work place.
- Only use the machine as it was intended.

Do not operate unless you are properly trained to safely operate this machine or you read, understand and obey:

- Operator's manuals and decals.
- Manufacturer's instructions and safety rules.
- Employer's safety rules.
- Applicable governmental regulations.

Electrocution Hazards

This machine is not electrically insulated and will not provide protection from contact with or proximity to electrical current.

Voltage	Minimum Safe Approach Distance	Warning
0 to 300 V	3.05 m	Avoid Contact
300 V to 500V	3.35 m	
500 V to 1000V	4.88 m	
1000 V to 2000V	6.10 m	
2000 V to 3000V	7.62 m	
3000 V to 5000V	10.67 m	
5000 V to 7500V	13.72 m	
7500 V to 10000V	15.24 m	

Tip-over Hazards

- Do not exceed rated load capacity.
- Do not raise platform unless machine is on a firm surface.
- Avoid drop-offs, holes and unstable or slippery surfaces.
- Do not raise platform unless machine is on a level surface.
- Do not drive machine on a slope that exceeds the maximum slope or side rating for the machine.
- Do not drive the machine on or near uneven terrain, unstable surfaces or other hazardous conditions with the platform raised.
- Do not push off or pull toward any object out side of the platform.
- Do not place or attach overhanging loads to any part of this machine.
- Use extreme care and slow speeds while driving the machine in stored position across uneven terrain, dents, unstable or slippery surfaces and near holes and drop-offs.

9414101

② 9414103

⚠ DANGER

Tip-over Hazard

If tilt-alarm sounds, unit is on a severe slope. Death or serious injury could occur.

9414103

1. Lower the platform. 2. Move the machine to level surface.

⑦ 9414109

⚠ CAUTION

Max. Manual Force

400N (Indoor)
200N (Outdoor)

9414109

③ 9334011

NOTICE

KEEP THE OPERATION AND SAFETY MANUAL WITH THE MACHINE

9334011

④ 9314013

Refer the operator to the instructions for use.

9314013

⑤ 9414123

Restraint only 1 Disconnect

9414123

⑨ 9514103

9514103

⑥ 9414069

⚠ DANGER

Crushing Hazard

Contact with moving parts will result in death or serious injury.

- Do not stand under or around platform during operation.
- Platform during operation.
- Keep away from moving parts.

Failure to follow these instructions could result in death or serious injury.

9414069

⑩ 9514201

CE

9514201

⑪ 9413013

⚠ DANGER

Crushing Hazard

Contact with moving parts will result in death or serious injury.

- Do not stand under or around platform during operation.
- Platform during operation.
- Keep away from moving parts.

Failure to follow these instructions could result in death or serious injury.

9413013

⑫ 9514301

9514301

⑬ 9313011

9313011

⑧ 9614065

JCPT0607DCS

Chassis

⑭ 9311011

9311011

⑰ 9311013

9311013

⑮ 9311511

Maximum Wheel Load
450 kg

9311511

⑱ 9311017

EMERGENCY LOWER

Pull knob to lower platform

9311017

⑲ 9311015

NOTICE

Cut off the power when the machine is repaired or not used for long period.

ON OFF

9311015

⑳ 9411011

⚠ DANGER

Explosion/Burn Hazard

Ignition of explosive gases or contact with corrosive acid will cause death, burns or blindness.

Keep all open flames and sparks away. Wear personal protective equipment, including face shield, gloves and long sleeve shirt.

READ MANUALS

Read all manuals prior to operation.

DO NOT OPERATE equipment if you do not understand the information in the manuals.

Consult your supervisor, the owner or the manufacturer.

9411011

㉑ 9411013

⚠ WARNING

THIS MACHINE MUST NOT BE USED UNTIL IT IS INSPECTED AND OPERATING PROPERLY.

- Do not operate this machine unless you have been properly trained by a qualified person and authorized to operate this machine. Your training includes reading and understanding the safety, operating and maintenance instructions in manufacturer's manuals, knowing your employer's work rules and applicable governmental regulations.
- Follow the instructions in the Operating Manual and applicable standards for daily, frequent, and annual inspections.
- Do not replace items (i.e., batteries, wheels, counterweight, etc.) with items of different weight or specification because this will affect stability of machine.
- Do not modify or change machine without written approval from manufacturer.
- Operate this machine with extreme caution. STOP all operation if malfunction occurs.
- Improper use of this machine could cause death or serious injury.

9411013

㉒ 9211013

CE Self-Propelled Scissor Lifts

Model _____

Serial No. _____

Voltage _____

Power _____

Rated Load _____

Max. Occupant _____

Max. Working Height _____

Max. Inclination _____

Max. Wind Speed _____

Max. Manual Force _____

Max. Work Pressure _____

Overall Dimension (LxWxH) _____

Gross Weight _____

IP _____

Date of MFG _____

Made in China

Zhejiang DingLi Machinery Co., Ltd

Addr: No. 1255 Bayun South Road, London Town, Qingdao, Zhejiang, China

Tel: 0086-572-8618588, 8681889

Fax: 0086-572-8681860

E-mail: market@cdingli.com

Http://www.cdlingli.com

Specifications**JCPT0607DCS**

Height, working maximum	5.6 m	Maximum hydraulic pressure (functions)	155 bar
Height, platform maximum	3.6 m	System voltage	24 V
Height, stowed maximum Rails up	2.03 m	Tire size	Φ230×80 mm
Height, stowed maximum Rails lowered	1.67 m	Airborne noise emissions	<70 dB
Width	0.76 m	Maximum sound level at normal operating workstations (A-weighted)	
Length, platform retracted	1.44 m	Vibration value does not exceed 2.5m/s ²	
Length, platform extended	2.04 m	Maximum slope rating, Stowed position	25%
Platform dimensions Platform length × width	1.29×0.7 m	Maximum side slope rating, Stowed position	25%
Platform extension length	0.6 m	Note: Slope rating is subject to ground conditions and adequate traction.	
Maximum load capacity	240 kg	Maximum working slope	X-1.5°, Y-3°
Maximum wind speed	12.5 m/s	Drive speeds	
Wheelbase	1.05 m	Stowed, maximum	4.0 km/h
Turning radius (outside)	1.55 m	Platform raised, maximum	1.1 km/h
Turning radius (inside)	0.4 m	Floor loading information	
Ground clearance	6 cm	Tire load, maximum	450 kg
Ground clearance Pothole guards deployed	1.5cm	Tire contact pressure	10.9 kg/cm ² 1068.2 kPa
Weight	880kg	Occupied floor pressure	1143.3 kg/m ² 11.2 kPa
Machine weights vary with option configurations		Note: Floor loading information is approximate and does not incorporate different option configurations. It should be used only with adequate safety factors.	
Power source	2 Batteries , 12V 85Ah		
Controls	Proportional		
AC outlet in platform	Standard		

Continuous improvement of our products is a DINGLI policy. Product specifications are subject to change without notice or obligation

Control Panel

Ground Control Panel

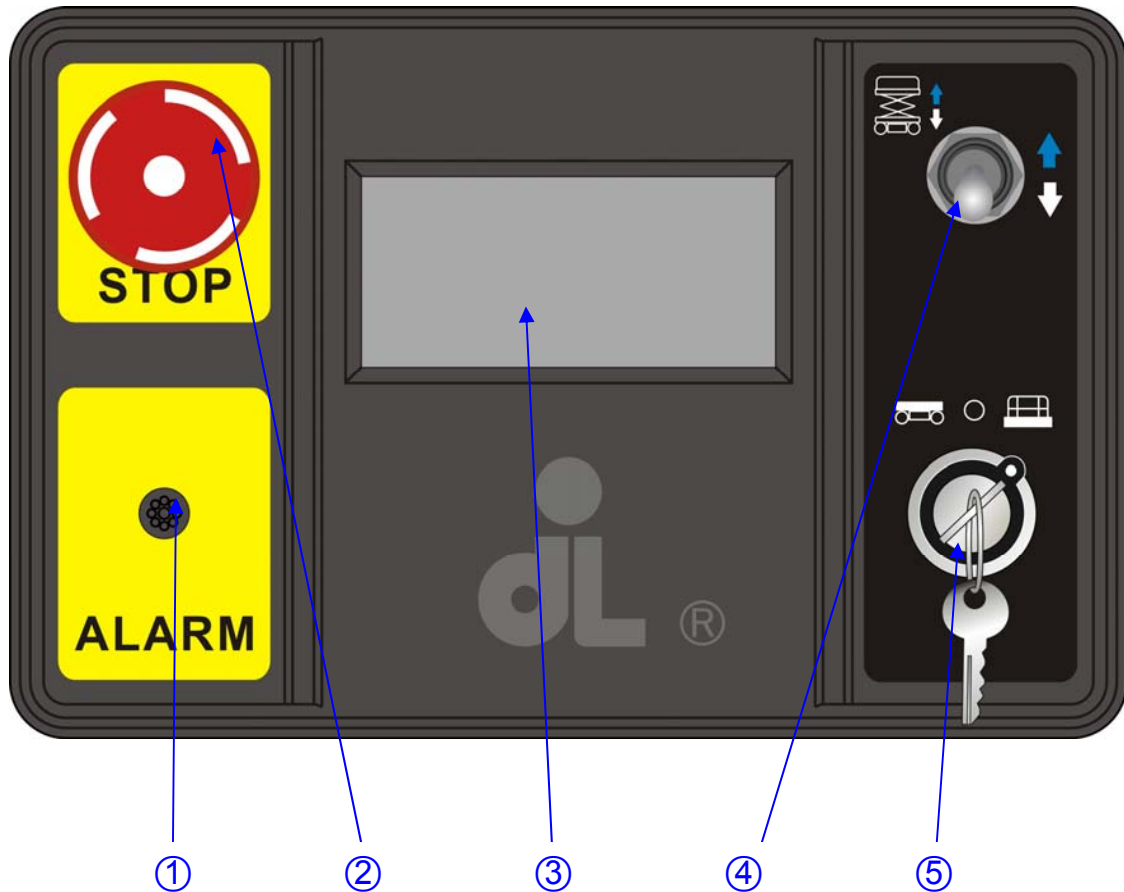

1 Alarm

2 Red Emergency Stop button

Push in the red Emergency Stop button to the off position to stop all functions. Pull out the red Emergency Stop button to the on position to operate the machine.

3 LED

4 Platform up / down Switch

Move the-switch UP and the platform will raise.

Move the-switch DOWN and the platform will lower.

5 Key switch for platform / off / ground control selection

Turn the key switch to the platform position and the platform controls will operate. Turn the key switch to the off position and the machine will be off. Turn the key switch to the ground position and the ground controls will operate.

Control Panel

Platform Control Panel

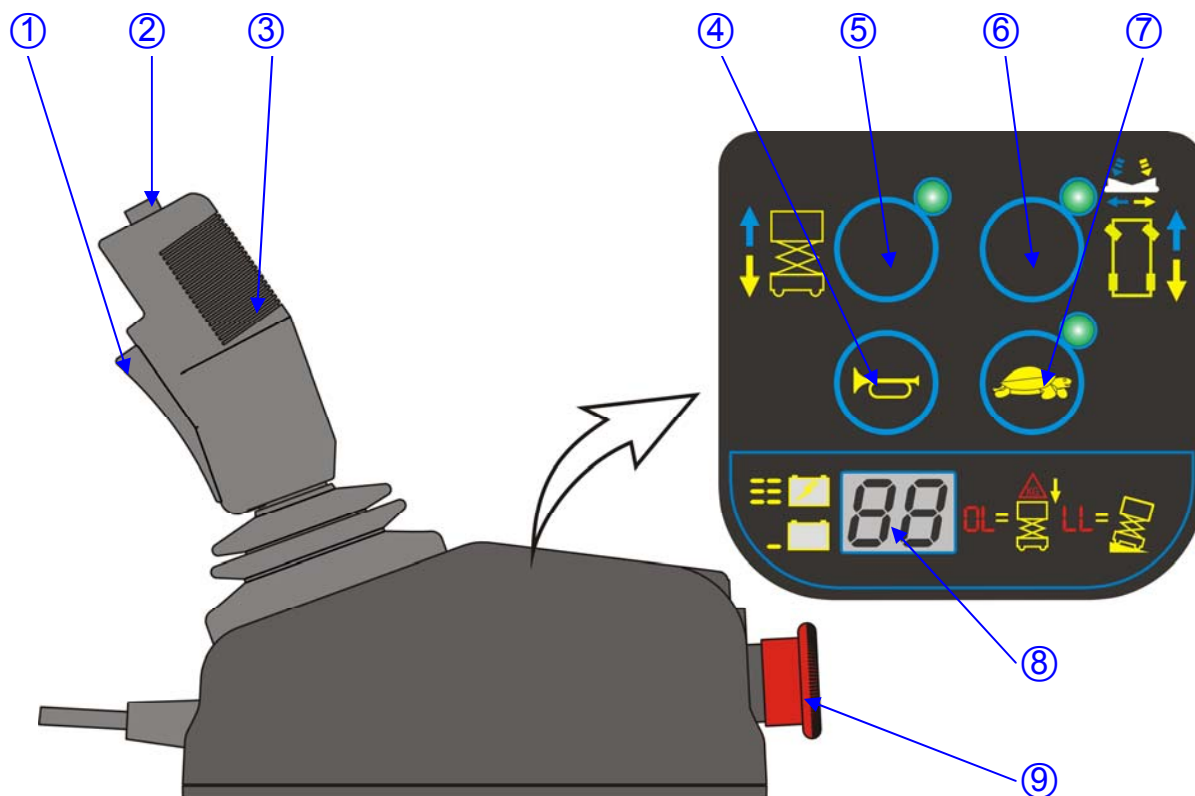

- 1 Function enable switch for lift and drive functions
- 2 Thumb rocker switch for steer functions
- 3 Proportional control handle
- 4 Horn button

- 5 Lift function select button
- 6 Drive function select button
- 7 Drive speed button
- 8 LED
- 9 Red Emergency Stop button

Control Panel

Platform Control Panel

- 1 Function enable switch for lift and drive functions

Lift function: Press and hold the function enable switch to enable the lift function on the platform control handle. Move the control handle in the direction indicated by the blue arrow and the platform will raise. Move the control handle in the direction indicated by the yellow arrow and the platform will lower. The descent alarm should sound while the platform is lowering.

Drive function: Press and hold the function enable switch to enable the drive function on the platform control handle. Move the control handle in the direction indicated by the blue up arrow on the control panel and the machine will move in the direction that the blue arrow points. Move the control handle in the direction indicated by the yellow down arrow on the control panel and the machine will move in the direction that the yellow arrow points.

Press and hold the function enable switch to enable the drive function on the platform control handle. Move the control handle in the direction indicated by the blue left arrow on the control panel and the machine will turn to the lift direction that the blue arrow points. Move the control handle in the direction indicated by the yellow right arrow on the control panel and the machine will turn to right direction that the yellow arrow points.

- 2 Thumb rocker switch for steer functions

Press the thumb rocker switch in either direction to activate steer function.

- 3 Proportional control handle

- 4 Horn Button

Push the horn button and the horn will sound. Release the horn button and the horn will stop.

- 5 Lift function select button

Press this button to activate the lift function.

- 6 Drive function select button

Press this button to activate the drive function.

- 7 Drive speed button

Press this button to activate the slow or fast drive function.

- 8 LED

Diagnostic read out and battery charge indicator.

- 9 Red Emergency Stop button

Push in the red Emergency Stop button to the off position to stop all functions. Pull out the red Emergency Stop button to the on position to operate the machine.

Pre-operation Inspection



Do Not Operate Unless:

You learn and practice the principles of safe machine operation contained in this operator's manual.

- 1 Avoid hazardous situations.
- 2 Always perform a pre-operation inspection.**

Know and understand the pre-operation inspection before going on to the next section.

- 3 Inspect the workplace.
- 4 Always perform function tests prior to use.
- 5 Only use the machine as it was intended.

Fundamentals

It is the responsibility of the operator to perform a pre-operation inspection and routine maintenance.

The pre-operation inspection is a visual inspection performed by the operator prior to each work shift. The inspection is designed to discover if anything is apparently wrong with a machine before the operator performs the function tests.

The pre-operation inspection also serves to determine if routine maintenance procedures are required. Only routine maintenance items specified in this manual may be performed by the operator.

Refer to the list on the next page and check each of the items.

If damage or any unauthorized variation from factory delivered condition is discovered, the machine must be tagged and removed from service.

Repairs to the machine may only be made by a qualified service technician, according to the manufacturer's specifications. After repairs are completed, the operator must perform a pre-operation inspection again before going on to the function tests.

Scheduled maintenance inspections shall be performed by qualified service technicians, according to the manufacturer's specifications and the manual.

Pre-operation Inspection

Pre-operation Inspection

- Be sure that the operator's manual are complete, legible and in the storage container located in the platform.
- Be sure that all decals are legible and in place. See Decals section.
- Check for hydraulic oil leaks and proper oil level. Add oil if needed. See Maintenance section.
- Check for battery fluid leaks and proper fluid level. Add distilled water if needed. See Maintenance section.

Check the following components or areas for damage, improperly installed or missing parts and unauthorized modifications:

- Electrical components, wiring and electrical cables
- Hydraulic hoses, fittings, cylinders and manifolds
- Battery pack and connections
- Drive motors
- Wear pads
- Tires and wheels
- Ground strap
- Limit switches, alarm, beacon and Potentiometer
- Nuts, bolts and other fasteners
- Platform overload components
- Platform entry gate
- Safety arm
- Platform extension(s)
- Scissor pins and retaining fasteners
- Platform control joystick
- Brake release components

Check entire machine for:

- Cracks in welds or structural components
- Dents or damage to machine
- Be sure that all structural and other critical components are present and all associated fasteners and pins are in place and properly tightened
- Be sure that the chassis trays are closed and latched and the batteries are properly connected.

Note: If the platform must be raised to inspect the machine, make sure the safety arm is in place. See Operating Instructions section.

Workplace Inspection



Do Not Operate Unless:

You learn and practice the principles of safe machine operation contained in this operator's manual.

- 1 Avoid hazardous situations.
- 2 Always perform a pre-operation inspection.
- 3 Inspect the workplace.**

Know and understand the workplace inspection before going on to the next section.

- 4 Always perform function tests prior to use.
- 5 Only use the machine as it was intended.

Fundamentals

The workplace inspection helps the operator determine if the workplace is suitable for safe machine operation. It should be performed by the operator prior to moving the machine to the workplace.

It is the operator's responsibility to read and remember the workplace hazards, then watch for and avoid them while moving, setting up and operating the machine.

Workplace Inspection

Be aware of and avoid the following hazardous situations:

- Drop-offs or holes
- Bumps, floor obstructions or debris
- Sloped surfaces
- Unstable or slippery surfaces
- Overhead obstructions and high voltage conductors
- Hazardous locations
- Inadequate surface support to withstand all load forces imposed by the machine
- Wind and weather conditions
- The presence of unauthorized personnel
- Other possible unsafe conditions

Function Tests



Do Not Operate Unless:

You learn and practice the principles of safe machine operation contained in this operator's manual.

- 1 Avoid hazardous situations.
- 2 Always perform a pre-operation inspection.
- 3 Inspect the workplace.
- 4 **Always perform function tests prior to use.**

Know and understand the function tests before going on to the next section.

- 5 Only use the machine as it was intended.

Fundamentals

The function tests are designed to discover any malfunctions before the machine is put into service.

The operator must follow the step-by-step instructions to test all machine functions.

A malfunctioning machine must never be used. If malfunctions are discovered, the machine must be tagged and removed from service. Repairs to the machine may only be made by a qualified service technician, according to the manufacturer's specifications.

After repairs are completed, the operator must perform a pre-operation inspection and function tests again before putting the machine into service.

Function Tests

- 1 Select a test area that is firm, level and free of obstruction.
- 2 Be sure the battery pack is connected.
- 3 Turn the main power switch to "on" position.

At the Ground Controls

- 4 Pull out the platform and ground red Emergency Stop buttons to the on position.
 - 5 Turn the key switch to ground control.
 - 6 Observe the diagnostic LED readout on the ECU window.
- ⊙ Result: The LED should look like the picture at underside



Test Emergency Stop

- 7 Push in the ground red Emergency Stop button to the off position.
- ⊙ Result: No functions should operate.
- 8 Pull out the red Emergency Stop button to the on position.

Test Up/Down Functions

A buzzer with different sound frequency is controlled in central system. The descent alarm sounds at 60 beeps per minute. The alarm that goes off when the machine is not level sounds at 150 beeps per minute.

- 9 Turn the key switch to off or platform position.
 - 10 Move up and hold the platform up / down switch.
- ⊙ Result: No function should operate.

- 11 Turn the key switch to ground control position.
- 12 Move up and hold the platform up / down switch.

⊙ Result: The platform should raise.

- 13 Move down and hold the platform up / down switch.

⊙ Result: The platform should lower then stop at the height is 1.3 m. The descent alarm should sound while the platform is lowering.

- 14 Move down and hold the platform up / down switch.

⊙ Result: The platform should lower to end. The descent alarm should sound while the platform is lowering.

Test the Emergency Lowering

- 15 Activate the up function and raise the platform approximately 60 cm.
 - 16 Pull the emergency lowering knob.
- ⊙ Result: The platform should lower. The descent alarm will not sound.
- 17 Turn the key switch to platform control.

At the Platform Controls

Test Emergency Stop

- 18 Push in the platform red Emergency Stop button to the off position.

⊙ Result: No functions should operate.

- 19 Pull the red Emergency Stop button out to the on position.

⊙ Result: The LED indicator light should come on.

Test the Horn

- 20 Push the horn button.

Function Tests

- ⊙ Result: The horn should sound.

Test Function Enable and Up/Down Functions

- 21 Do not hold the function enable switch on the control handle.

- 22 Slowly move the control handle in the direction indicated by the blue arrow, then in the direction indicated by the yellow arrow.

- ⊙ Result: No functions should operate.

- 23 Press the lift function select button.

- 24 Press and hold the function enable switch on the control handle.

- 25 Slowly move the control handle in the direction indicated by the blue arrow.

- ⊙ Result: The platform should raise.

- 26 Release the control handle.

- ⊙ Result: The platform should stop raising.

- 27 Press and hold the function enable switch. Slowly move the control handle in the direction indicated by the yellow arrow.

- ⊙ Result: The platform should lower. The descent alarm should sound while the platform is lowering.

Test the Steering

Note: When performing the steer and drive function tests, stand in the platform facing the steer end of the machine.

- 28 Press the drive function select switch.

- 29 Press and hold the function enable switch on the control handle.

- 30 Depress the thumb rocker switch on top of the control handle in the direction identified by the blue left arrow on the control panel.

- ⊙ Result: The steer wheels should turn in the direction that the blue left arrow points on

the control panel.

- 31 Depress the thumb rocker switch in the direction identified by the white right arrow on the control panel.

- ⊙ Result: The steer wheels should turn in the direction that the white right arrow points on the control panel.

Test Drive and Braking

- 32 Press and hold the function enable switch on the control handle.

- 33 Slowly move the control handle in the direction indicated by the blue up arrow on the control panel until the machine begins to move, then return the handle to the center position.

- ⊙ Result: The machine should move in the direction that the blue up arrow points on the control panel, then come to an abrupt stop.

- 34 Press and hold the function enable switch on the control handle.

- 35 Slowly move the control handle in the direction indicated by the yellow down arrow on the control panel until the machine begins to move, then return the handle to the center position.

- ⊙ Result: The machine should move in the direction that the yellow down arrow points on the control panel, then come to an abrupt stop.

Note: The brakes must be able to hold the machine on any slope it is able to climb.

Test Limited Drive Speed

- 36 Press the lift function enable switch. Raise the platform approximately 1.3 m from the ground.

- 37 Press and hold the function enable switch on the control handle.

- 38 Slowly move the control handle to the full

Function Tests

drive position.

- ⊙ Result: The maximum achievable drive speed with the platform raised should not exceed 30.5cm/s.
- ⊗ If the drive speed with the platform raised exceeds 30.5 cm/s, immediately tag and remove the machine from service.

Test the Tilt Sensor Operation

Note: Perform this test from the ground with the platform controller. Do not stand in the platform.

- 39 Fully lower the platform.
- 40 Place a 3×20 cm or similar piece of wood under both wheels on one side and drive the machine up onto them.
- 41 Raise the platform at least 1.3 m.
- ⊙ Result: The platform should stop and the tilt alarm will sound at 150 beeps per minute.
- 42 Move the drive control handle in the direction indicated by the blue up arrow, then move the drive control handle in the direction indicated by the white down arrow.
- ⊙ Result: The drive function should not work in either direction.
- 43 Lower the platform and drive the machine off the block.

Test the Pothole Guards

Note: The pothole guards should automatically deploy when the platform is raised. The pothole guards activate another limit switch which allows the machine to continue to function. If the pothole guards do not deploy, an alarm sounds and the machine will not drive.

- 44 Raise the platform.
- ⊙ Result: When the platform is raised 1.3 m from the ground, the pothole guards should

deploy.

- 45 Press on the pothole guards on one side, and then the other.
- ⊙ Result: The pothole guards should not move.
- 46 Lower the platform.
- ⊙ Result: The pothole guards should return to the stowed position.
- 47 Place a 3×20 cm or similar piece of wood under a pothole guard. Raise the platform.
- ⊙ Result: Before the platform is raised 2 m from the ground, an alarm should sound and the drive function should not work.
- 48 Lower the platform and remove the 2×20 cm wood block.

Operating Instructions



Do Not Operate Unless:

- You learn and practice the principles of safe machine operation contained in this operator's manual.
- 1 Avoid hazardous situations.
- 2 Always perform a pre-operation inspection.
- 3 Inspect the workplace.
- 4 Always perform function tests prior to use.
- 5 **Only use the machine as it was intended.**

Fundamentals

This machine is a self-propelled hydraulic lift equipped with a work platform on the scissor mechanism. Vibrations emitted by these machines are not hazardous to an operator in the work platform. The machine can be used to position personnel with their tools and supplies at position above ground level and can be used to reach work areas located above and over machinery or equipment.

The Operating Instructions section provides instructions for each aspect of machine operation.

It is the operator's responsibility to follow all the safety rules and instructions in the operator's, safety and responsibilities manuals.

Using the machine for anything other than lifting personnel, along with their tools and materials, to an aerial work site is unsafe and dangerous.

Only trained and authorized personnel should be permitted to operate a machine. If more than one operator is expected to use a machine at different times in the same work shift, they must all be qualified operators and are all expected to follow all safety rules and instructions in the operator's, safety and responsibilities manuals. That means every new operator should perform a pre-operation inspection, function tests, and a workplace inspection before using the machine.

Operating Instructions

Emergency Stop

Push in the red Emergency Stop button to the off position at the ground controls or the platform controls to stop all machine functions.

Repair any function that operates when either red Emergency Stop button is pushed in.

Emergency Lowering

- 1 Pull the emergency lowering knob.

Operation from Ground

- 1 Turn the key switch to ground control.
- 2 Pull out both ground and platform red Emergency Stop buttons to the on position.
- 3 Be sure the battery pack is connected before operating the machine.

To Position Platform

- 1 Move the up/down toggle switch according to the markings on the control panel.

Drive and steer functions are not available from the ground controls.

Operation from Platform

- 1 Turn the key switch to platform control.
- 2 Pull out the ground and platform red Emergency Stop buttons to the on position.
- 3 Be sure the battery pack is connected before operating the machine.

To Position Platform

- 1 Press the lift function select button.
- 2 Press and hold the function enable switch on the control handle.

- 3 Move the control handle according to the markings on the control panel.

To Steer

- 1 Press the drive function select button.
- 2 Press and hold the function enable switch on the control handle.
- 3 Turn the steer wheels with the thumb rocker switch located on the top of the control handle.

To Drive

- 1 Press the drive function select button.
- 2 Press and hold the function enable switch on the control handle.
- 3 Increase speed: Slowly move the control handle off center.

Decrease speed: Slowly move the control handle toward center.

Stop: Return the control handle to center or release the function enable switch.

Use the color-coded direction arrows on the platform controls to identify the direction the machine will travel.

Machine travel speed is restricted when the platform is raised.

Battery condition will affect machine performance. Machine drive speed and function speed will drop when the battery level indicator is flashing.

To reduce drive speed

The drive controls can operate in two different drive speed modes. When the drive speed button light is on, slow drive speed mode is active. When the button light is off, fast drive speed mode is active.

Press the drive speed button to select the desired drive speed.

Operating Instructions

▲ Driving on a slope

Determine the slope and side slope ratings for the machine and determine the slope grade.

Maximum slope rating, stowed position 25%,

Maximum side slope rating, stowed position 25%.

Note: Slope rating is subject to ground conditions and adequate traction.

Press the drive speed button to the fast drive speed mode.

To determine the slope grade

Measure the slope with a digital inclinometer OR use the following procedure.

You will need:

Carpenter's level

Straight piece of wood, at least 1 m long

Tape measure

Lay the piece of wood on the slope.

At the downhill end, lay the level on the top edge of the piece of wood and lift the end until the piece of wood is level.

While holding the piece of wood level, measure the distance from the bottom of the piece of wood to the ground.

Divide the tape measure distance (rise) by the length of the piece of wood (run) and multiply by 100.

Example:

Run = 3.6 m

Rise = 0.3 m

$0.3 \text{ m} \div 3.6 \text{ m} = 0.083 \times 100 = 8.3\%$



If the slope exceeds the maximum slope or side slope rating, the machine must be winched or transported up or down the slope. See Transport and Lifting section.

Operation from Ground with Controller

Maintain safe distances between operator, machine and fixed objects.

Be aware of the direction the machine will travel when using the controller.

Battery Level Indicator



Use the LED diagnostic readout to determine the battery level.

How to use the Safety Arm

- 1 Raise the platform approximately 2.2m from the ground.
- 2 Rotate the safety arm away from the machine and let it hang down.
- 3 Lower the platform until the safety arm rests securely on the link. Keep clear of the safety arm when lowering the platform.

▲ DANGER Don't engage the safety arm unless unload the platform.

How to Fold Down the Guardrails

The platform railing system consists of three fold down rail section for the extension deck and three sections for the main deck. All sections are held in place by four wire lock pins.

- 1 Fully lower the platform and retract the platform extension.
- 2 Remove the platform controls.
- 3 From inside the platform, remove the two front extension deck wire lock pins.

Operating Instructions

- 4 Fold down the front rail assembly. Keep hands clear of pinch points.
 - 5 Replace the two removed pins back into each side rail bracket.
 - 6 Fold down the extension platform right rail assembly. Keep hands clear of pinch points.
 - 7 Fold down the extension platform left rail assembly. Keep hands clear of pinch points.
 - 8 Carefully open the gate and move to the rear step or the ground.
 - 9 From the rear step or from the ground, remove the right rear main deck wire lock pins.
 - 10 Fold down the right rail assembly. Keep hands clear of pinch points.
 - 11 Replace the removed pin back into rear rail bracket.
 - 12 Remove the left rear main deck wire lock pins.
 - 13 Fold down the left rail assembly. Keep hands clear of pinch points.
 - 14 Replace the removed pin back into rear rail bracket.
 - 15 Fold down the rear rail assemble. Keep hands free of pinch points.
- Do not stand on the platform extension while trying to extend it.

How to Raise the Guardrails

Follow the fold down instructions but in reverse order.

To Extend and Retract Platform

- 1 Press the platform lock pin pedal on the extension deck by foot.
- 2 Push the platform extension guardrail to extend the platform to the desired position.

Operating Instructions

Error indicator readout

Alarm code	Description
10	GENERAL ALARM ECU
20	GENERAL ALARM TM1
30	GENGRAL ALARM PCU
31	PCU CPU0 FAULT
32	PCU CPU1 FAULT
51	ECU ALARM
52	PCU ALARM
53	TM1 ALARM
54	PRESS SENSOR ERROR
57	OVERLOAD
58	POTHOLE
59	HIGH POSTION LIMIT
61	TILTING X
62	TILTING Y
63	ANTI-HAND CLAMP
64	LEFT BRAKE ERROR
65	RIGHT BRAKE ERROR
66	BATTERY LOW
69	POWER RELAY SLEEP
90	TM1 PCB HOT
91	TM1 RADIATOR HOT
95	TRACATION TUNING NOT DONE
98	BRAKE RELESAE
99	BYPASS
101	ECU E2PROM ALARM
102	ECU WATCHDOG FAULT
110	CANBUS TIMEOUT 1 PCU CPU0
111	CANBUS TIMEOUT 2 PCU CPU0
112	CANBUS TIMEOUT 1 PCU CPU1

Operating Instructions

Alarm code	Description
113	CANBUS TIMEOUT 2 PCU CPU1
114	CANBUS TIMEOUT TM
115	CANBUS TIMEOUT SCISSOR ANGLE SENSOR
116	PRESSURE SENSOR REDUNDANT CHECK FAULT
117	ANALOG SCISSOR ANGLE REDUNDANT CHECK FAULT
120	KEY SWITCH INPUT CHECK FAULT
121	TOGGLE SWITCH INPUT CHECK FAULT
122	PIN29, INP00 REDUNDANT CHECK FAULT
123	PIN30, INP01 REDUNDANT CHECK FAULT
124	PIN32, INP02 REDUNDANT CHECK FAULT
125	PIN33, INP03 REDUNDANT CHECK FAULT
126	PIN06, INP04 REDUNDANT CHECK FAULT
127	PIN34, INP05 REDUNDANT CHECK FAULT
128	PIN45, INP10 REDUNDANT CHECK FAULT
129	PIN46, INP11 REDUNDANT CHECK FAULT
130	PIN47, INP12 REDUNDANT CHECK FAULT
131	PIN48, INP13 REDUNDANT CHECK FAULT
132	PIN49, INP14 REDUNDANT CHECK FAULT
133	PIN50, INP15 REDUNDANT CHECK FAULT
134	PIN19, INP RELAY REDUNDANT CHECK FAULT
135	PIN20, INP BRAKE REDUNDANT CHECK FAULT
136	PIN23, INP M1 REDUNDANT CHECK FAULT
137	PIN24, INP M2 REDUNDANT CHECK FAULT
140	PRESSURE SENSOR N.1 OPEN CIRCUIT OR SHORT TO GND
141	PRESSURE SENSOR N.1 SHORT CIRCUIT TO PWR
142	PRESSURE SENSOR N.1 VALUE LOWER THAN THRESHOLD MIN.
143	PRESSURE SENSOR N.1 VALUE GREATER THAN THRESHOLD MAX.
144	PRESSURE SENSOR N.2 OPEN CIRCUIT OR SHORT TO GND
145	PRESSURE SENSOR N.2 SHORT CIRCUIT TO PWR
146	PRESSURE SENSOR N.2 VALUE LOWER THAN THRESHOLD MIN.

Operating Instructions

Alarm code	Description
147	PRESSURE SENSOR N.2 VALUE GREATER THAN THRESHOLD MAX.
149	ANALOG SCISSOR ANGLE CHANNEL A: OPEN CIRCUIT OR SHORT TO GND
150	ANALOG SCISSOR ANGLE CHANNEL A: SHORT CIRCUIT TO PWR
151	ANALOG SCISSOR ANGLE CHANNEL A: ANGLE VALUE LOWER THAN MIN.
152	ANALOG SCISSOR ANGLE CHANNEL A: ANGLE VALUE GREATER THAN MAX.
153	ANALOG SCISSOR ANGLE CHANNEL B: OPEN CIRCUIT OR SHORT TO GND
154	ANALOG SCISSOR ANGLE CHANNEL B: SHORT CIRCUIT TO PWR
155	ANALOG SCISSOR ANGLE CHANNEL B: ANGLE VALUE LOWER THAN MIN.
156	ANALOG SCISSOR ANGLE CHANNEL B: ANGLE VALUE GREATER THAN MAX.
160	PIN01, OUT00 REDUNDANT CHECK FAULT
161	PIN02, OUT01 REDUNDANT CHECK FAULT
162	PIN04, OUT02 REDUNDANT CHECK FAULT
163	PIN05, OUT03 REDUNDANT CHECK FAULT
164	PIN08, OUT04 REDUNDANT CHECK FAULT
165	PIN09, OUT05 REDUNDANT CHECK FAULT
166	PIN11, OUT06 REDUNDANT CHECK FAULT
167	PIN13, OUT07 REDUNDANT CHECK FAULT
168	PIN17, OUT08 REDUNDANT CHECK FAULT
169	PIN18, OUT09 REDUNDANT CHECK FAULT
170	PIN21, OUT10 REDUNDANT CHECK FAULT
171	PIN22, OUT POWERRELAY REDUNDANT CHECK FAULT
172	PIN25, OUT BRAKE1 REDUNDANT CHECK FAULT
173	PIN26, OUT BRAKE2 REDUNDANT CHECK FAULT
201	TM1 ERR PUMP CURRENT SENSOR OFFSET
202	TM1 ERR TRAC1 CURRENT SENSOR OFFSET
203	TM1 ERR TRAC2 CURRENT SENSOR OFFSET
204	TM1 ERR LOAD HW PARAMETER
205	TM1 ERR LOAD PARAMETER
210	TM1 ERR POWER SUPPLY OUT OF LIMIT
211	TM1 ERR POWER RELAY STUCK

Operating Instructions

Alarm code	Description
212	TM1 ERR PRECHARGE NOT DONE
213	TM1 ERR POWER RELAY OPEN CIRCUIT
220	TM1 ERR PUMP OVER CURRENT
221	TM1 ERR TRAC1 OVER CURRENT
222	TM1 ERR TRAC2 OVER CURRENT
223	TM1 ERR OVER TENSION
224	TM1 ERR UNDER TENSION
225	TM1 ERR HIGH TEMP PCB
226	TM1 ERR HIGH TEMP RADIATOR
227	TM1 ERR OUT1 OVER CURRENT
228	TM1 ERR OUT2 OVER CURRENT
229	TM1 ERR OUT3 OVER CURRENT
230	TM1 ERR WDO
231	TM1 ERR WDO PER DATA VALIDITY
232	AL TM PUMP MOTOR OPEN
233	AL TM M1 OPEN
234	AL TM M2 OPEN
235	AL TM M1 WIRING
236	AL TM M2 WIRING
237	AL TM EXITATION OPEN
238	AL TM EXITATION WIRING
300	AL PCU INITCHECK
301	PCU C0 FAULTCODE
302	PCU C1 FAULTCODE

Operating Instructions

Code	Trouble shooting
10	System Initialization Fault: ECU may be malfunctioning, replace it. System Communication Fault: Check communications cable connections and other wiring. If that does not resolve the problem, try replacing the PCU or ECU.
20	System Initialization Fault: TM1 may be malfunctioning, replace it.
30	System Initialization Fault: PCU may be malfunctioning, replace it. System Communication Fault: Check communications cable connections and other wiring. If that does not resolve the problem, try replacing the PCU or ECU.
31	Replace PCU
32	Replace PCU
51	System Initialization Fault: ECU may be malfunctioning, replace it. System Communication Fault: Check communications cable connections and other wiring. If that does not resolve the problem, try replacing the PCU or ECU.
52	System Initialization Fault: PCU may be malfunctioning, replace it. System Communication Fault: Check communications cable connections and other wiring. If that does not resolve the problem, try replacing the PCU or ECU.
53	System Initialization Fault: TM1 may be malfunctioning, replace it.
54	Pressure Sensor Fault: Check the wiring to the sensor and then the sensor itself. Also check to make sure that the correct option is properly selected (or not) for load sensing
55	Angle Sensor Fault: Check the wiring to the sensor and then the sensor itself. Also check to make sure that the correct option is properly selected (or not) for load sensing
56	Level Sensor Fault: Check the wiring to the sensor and then the sensor itself. Also check to make sure that the correct option is properly selected (or not) for load sensing
57	Overloaded Platform Fault: Remove the excess load immediately
58	Pothole Guard Fault: Check that the pothole guards are extended, check the pothole limit switches. Check wires to the switches, check the down limit switch and connections
59	The platform touch the highest position
60	The platform touch the 2.5 m position if outdoor status
61	Machine Tilted Beyond Safe Limits Fault: If the machine is tilted, find a way to make it level.

Operating Instructions

Code	Trouble shooting
62	Machine Tilted Beyond Safe Limits Fault: If the machine is tilted, find a way to make it level.
63	The platform touch the Anti-hand clamp position
64	Left Brake Coil Fault: Check the connections to the Coil's terminals and make sure they are tight. If so, check the coil itself to see if it is open or shorted.
65	Right Brake Coil Fault: Check the connections to the Coil's terminals and make sure they are tight. If so, check the coil itself to see if it is open or shorted.
66	Charge battery
69	Restart the power
90	TM1 over current
91	TM1 over current
95	Turning the traction motor
99	Bypass was enabled by human
101-115	Please contact manufacturers or replace ECU
201-231	Please contact manufacturers or replace TM1

For more information, please consult the appropriate Dingli Service Dept.

Operating Instructions



Battery and Charger Instructions

Observe and Obey:

- Do not use an external charger or booster battery.
- Charge the battery in a well-ventilated area.
- Use proper AC input voltage for charging as indicated on the machine.
- Use only a Dingli authorized battery and charger.

Dry Battery Filling and Charging Instructions

- 1 Remove the battery vent caps and permanently remove the plastic seal from the battery vent openings.
- 2 Fill each cell with battery acid (electrolyte) until the level is sufficient to cover the plates.

Do not fill to the maximum level until the battery charge cycle is complete. Overfilling can cause the battery acid to overflow during charging.

Neutralize battery acid spills with baking soda and water.

- 3 Install the battery vent caps.
- 4 Charge the battery.
- 5 Check the battery acid level when the charging cycle is complete. Replenish with distilled water to the bottom of the fill tube. Do not overfill.

To Charge Battery

- 1 Be sure the battery is connected before charging.
- 2 Open the battery compartment. The compartment should remain open for the entire charging cycle.

Maintenance - free battery

- 3 Connect the battery charger to a grounded AC circuit.
- 4 The charger will indicate when the battery is fully charged.

Standard Battery

- 5 Remove the battery vent caps and check the battery acid level. If necessary, add only enough distilled water to cover the plates. Do not overfill prior to the charge cycle.
- 6 Replace the battery vent caps.
- 7 Connect the battery charger to a grounded AC circuit.
- 8 The charger will indicate when the battery is fully charged.
- 9 Check the battery acid level when the charging cycle is complete. Replenish with distilled water to the bottom of the fill tube. Do not overfill.

Transport and Lifting Instructions



Observe and Obey:

- ✓ Common sense and planning must be applied to control the movement of the machine when lifting it with a crane or forklift.
- ✓ The transport vehicle must be parked on a level surface.
- ✓ The transport vehicle must be secured to prevent rolling while the machine is being loaded.
- ✓ Be sure the vehicle capacity, loading surfaces and chains or straps are sufficient to withstand the machine weight. See the serial label for the machine weight.
- ✓ The machine must be on a level surface or secured before releasing the brakes.

Brake Release Operation

- 1 Chock the wheels to prevent the machine from rolling.
- 2 Pull out the red Emergency Stop button on both the ground and platform controls to the on position.
- 3 Press and hold lift switch to "down" position in ground control, meanwhile turn on the key switch to the "Ground" position. The brake will be released after Alarm alerts.
- 4 If you want to close the brake release, just turn off the key switch in "ground" position.

Towing the Model is not recommended. If the machine must be towed, do not exceed 4.0 km/h.

After the machine is loaded:

- 1 Push in both ground and platform red Emergency Stop buttons to the off position.
- 2 Turn the key switch to the off position.
- 3 Chock the wheels to prevent the machine from rolling.

Transport and Lifting Instructions

Securing to Truck or Trailer for Transit

Always chock the machine wheels in preparation for transport.

Turn the key switch to the off position and remove the key before transporting.

Inspect the entire machine for loose or unsecured items.

Securing the Chassis

Use the tie-down points on the chassis for anchoring down to the transport surface.

Use a minimum of four chains or straps.

Use chains or straps of ample load capacity.

Adjust the rigging to prevent damage to the chains.

Lifting the Machine with a Forklift

Be sure the extension deck, controls and component trays are secure.

Remove all loose items on the machine.

Fully lower the platform.

The platform must remain lowered during all loading and transport procedures.

Position the forklift forks in position with the forklift pockets.

Drive forward to the full extent of the forks.

Raise the machine 15 cm and then tilt the forks back slightly to keep the machine secure.

Be sure the machine is level when lowering the forks.

Maintenance



Observe and Obey:

- ✓ Only routine maintenance items specified in this manual shall be performed by the operator.
- ✓ Scheduled maintenance inspections shall be completed by qualified service technicians, according to the manufacturer's specifications and the requirements specified in the responsibilities manual.

Maintenance Symbols Legend

NOTICE The following symbols have been used in this manual to help communicate the intent of the instructions. When one or more of the symbols appear at the beginning of a maintenance procedure, it conveys the meaning below.



Indicates that tools will be required to perform this procedure.



Indicates that new parts will be required to perform this procedure.



Indicates that dealer service will be required to perform this procedure.

Pre-delivery Preparation Report

The pre-delivery preparation report contains checklists for each type of scheduled inspection.

Make copies of the Pre-delivery Preparation report to use for each inspection. Store completed forms as required.

Maintenance Schedule

There are five types of maintenance inspections that must be performed according to a schedule—daily, quarterly, semi-annually, annually, and two year. The Scheduled Maintenance Procedures Section and the Maintenance Inspection Report have been divided into five subsections—A, B, C, D, and E. Use the following chart to determine which group(s) of procedures are required to perform a scheduled inspection.

Inspection	Checklist
Daily or every 8 hours	A
Quarterly or every 250 hours	A+B
Semi-annually or every 500 hours	A+B+C
Annually or every 1000 hours	A+B+C+D
Two year or every 2000 hours	A+B+C+D+E

Maintenance Inspection Report

The maintenance inspection report contains checklists for each type of scheduled inspection.

Make copies of the Maintenance Inspection Report to use for each inspection. Maintain completed forms for a minimum of 4 years or in compliance with your employer, jobsite and governmental regulations and requirements.

Maintenance

Pre-delivery Preparation Report

Fundamentals

It is the responsibility of the dealer to perform the Pre-delivery Preparation.

The Pre-delivery Preparation is performed prior to each delivery. The inspection is designed to discover if anything is apparently wrong with a machine before it is put into service.

A damaged or modified machine must never be used. If damage or any variation from factory delivered condition is discovered, the machine must be tagged and removed from service.

Repairs to the machine may only be made by a qualified service technician, according to the manufacturer's specifications.

Scheduled maintenance inspections shall be performed by qualified service technicians, according to the manufacturer's specifications and the requirements listed in the responsibilities manual.

Instructions

Use the operator's manual on your machine.

The Pre-delivery Preparation consists of completing the Pre-operation Inspection, the Maintenance items and the Function Tests.

Use this form to record the results. Place a check in the appropriate box after each part is completed. Follow the instructions in the operator's manual.

If any inspection receives an N, remove the machine from service, repair and re-inspect it. After repair, place a check in the R box.

Legend

Y = yes, completed

N = no, unable to complete

R = repaired

Comments

Pre-Delivery Preparation	Y	N	R
Pre-operation inspection completed			
Maintenance items completed			
Function tests completed			

Model

Serial number

Date

Machine owner

Inspected by (print)

Inspector signature

Inspector title

Inspector company

Maintenance**Maintenance Inspection Report**

Model
Serial number
Date
Hour meter
Machine owner
Inspected by (print)
Inspector signature
Inspector title
Inspector company

Instructions

- Make copies of this report to use for each inspection.
- Select the appropriate checklist(s) for the type of inspection to be performed.

<input type="checkbox"/> Daily or 8 hours Inspection:	A
<input type="checkbox"/> Quarterly or 250 hours Inspection:	A+B
<input type="checkbox"/> Semi-annually or 500 hours Inspection:	A+B+C
<input type="checkbox"/> Annually or 1000 hours Inspection:	A+B+C+D
<input type="checkbox"/> Two year or 2000 hours Inspection:	A+B+C+D+E

- Place a check in the appropriate box after each inspection procedure is completed.
- Use the step-by-step procedures in this section to learn how to perform these inspections.
- If any inspection receives an "N", tag and remove the machine from service, repair and re-inspect it. After repair, place a check in the "R" box.

Legend

- Y = yes, acceptable
 N = no, remove from service
 R = repaired

Checklist A	Y	N	R
A-1 Inspect the manuals and decals			
A-2 Pre-operation inspection			
A-3 Check the Batteries			
A-4 Check the Hydraulic Oil Level			
A-5 Function tests			
Perform after 40 hours:			
A-6 30 day service			

Checklist B	Y	N	R
B-1 Batteries			
B-2 Electrical wiring			
B-3 Tires and wheels			
B-4 Emergency stop			
B-5 Key switch			
B-6 Horn (if equipped)			
B-7 Drive brakes			
B-8 Drive speed - stowed			
B-9 Drive speed - raised			
B-10 Drive speed - slow			
B-11 Hydraulic oil analysis			
B-12 Tank venting system			

Checklist C	Y	N	R
C-1 Platform overload (if equipped)			
C-2 Breather cap - models with optional oil			

Checklist D	Y	N	R
D-1 Scissor arm wear pads			

Checklist E	Y	N	R
E-1 Hydraulic oil			

Maintenance

Checklist A Procedures

A-1

Inspect the Manuals and Decals

Maintaining the operator's and safety manuals in good condition is essential to safe machine operation. Manuals are included with each machine and should be stored in the container provided in the platform. An illegible or missing manual will not provide safety and operational information necessary for a safe operating condition.

In addition, maintaining all of the safety and instructional decals in good condition is mandatory for safe machine operation. Decals alert operators and personnel to the many possible hazards associated with using this machine. They also provide users with operation and maintenance information. An illegible decal will fail to alert personnel of a procedure or hazard and could result in unsafe operating conditions.

- 1 Check to make sure that the manuals are present and complete in the storage container on the platform.
 - 2 Examine the pages of manual to be sure that they are legible and in good condition.
- ☉ Result: The operator manual is appropriate for the machine and the manual are legible and in good condition.
- ☒ Result: The operators manual is not appropriate for the machine or the manual is not in good condition or is illegible. Remove the machine from service until the manual is replaced.
- 3 Open the operator manual to the decals inspection section. Carefully and thoroughly inspect all decals on the machine for legibility and damage.

☉ Result: The machine is equipped with all required decals, and all decals are legible and in good condition.

☒ Result: The machine is not equipped with all required decals, or one or more decals are illegible or in poor condition. Remove the machine from service until the decals are replaced.

- 4 Always return the manual to the storage container after use.

Note: Contact your authorized DINGLI distributor or DINGLI machinery if replacement manuals or decals are needed.

Maintenance

A-2

Perform Pre-operation Inspection

Completing a Pre-operation Inspection is essential to safe machine operation. The Pre-operation Inspection is a visual inspection performed by the operator prior to each work shift. The inspection is designed to discover if anything is apparently wrong with a machine before the operator performs the function tests. The Pre-operation Inspection also serves to determine if routine maintenance procedures are required.

Complete information to perform this procedure is available in the appropriate operator manual. Refer to the Operator Manual on your machine.

A-3

Check the Batteries



Proper battery condition is essential to good machine performance and operational safety. Improper fluid levels or damaged cables and connections can result in component damage and hazardous conditions.

⚠ WARNING Electrocution hazard. Contact with hot or live circuits may result in death or serious injury. Remove all rings, watches and other jewelry.

⚠ WARNING Bodily injury hazard. Batteries contain acid. Avoid spilling or contacting battery acid. Neutralize battery acid spills with baking soda and water.

- 1 Put on protective clothing and eye wear.
- 2 Be sure that the battery cable connections are tight and free of corrosion.
- 3 Be sure that the battery hold-down bars are secure.
- 4 Remove the battery vent caps.
- 5 Check the battery acid level. If needed, replenish with distilled water to the bottom of the battery fill tube. Do not overfill.
- 6 Install the vent caps.

Maintenance

A-4

Check the Hydraulic Oil Level



Maintaining the hydraulic oil at the proper level is essential to machine operation. Improper hydraulic oil levels can damage hydraulic components. Daily checks allow the inspector to identify changes in oil level that might indicate the presence of hydraulic system problems.

NOTICE

Perform this procedure with the platform in the stowed position and the motor off.

- 1 Remove the hydraulic oil dipstick (fill cap), wipe it clean and reinstall it.
- 2 Take the hydraulic oil dipstick out again, and check the oil level.
- 3 If the hydraulic oil level is too low and add new hydraulic oil to the prescribed level.

Hydraulic oil specifications

L-HV46

A-5

Perform Function Tests

Completing the function tests is essential to safe machine operation. Function tests are designed to discover any malfunctions before the machine is put into service. A malfunctioning machine must never be used. If malfunctions are discovered, the machine must be tagged and removed from service.

Complete information to perform this procedure is available in the appropriate operator manual. Refer to the Operator Manual on your machine.

A-6**Perform 30 Day Service**

The 30 day maintenance procedure is a one time procedure to be performed after the first 30 days or 40 hours of usage. After this interval, refer to the maintenance tables for continued scheduled maintenance.

Perform the following maintenance procedures:

B-3 Inspect the Tires, Wheels and lock Nut Torque

Maintenance

Checklist B Procedures

B-1

Inspect the Batteries



DINGLI requires that this procedure be performed every 250 hours or quarterly, whichever comes first.

Proper battery condition is essential to good machine performance and operational safety. Improper fluid levels or damaged cables and connections can result in component damage and hazardous conditions.

⚠ WARNING Electrocutation / burn hazard. Contact with electrically charged circuits could result in death or serious injury. Remove all rings, watches and other jewelry.

⚠ WARNING Bodily injury hazard. Batteries contain acid. Avoid spilling or contacting battery acid. Neutralize battery acid spills with baking soda and water.

- 1 Put on protective clothing and eye wear.
- 2 Side out tray and away from the chassis.
- 3 Be sure that the battery cable connections are free of corrosion.

Note: Adding terminal protectors and a corrosion preventative sealant will help eliminate corrosion on the battery terminals and cables.

- 4 Be sure that the battery retainers and cable connections are tight.
- 5 Fully charge the batteries. Allow the batteries to rest 24 hours before performing this procedure to allow the battery cells to equalize.

Models without maintenance-free or sealed batteries:

- 6 Remove the battery vent caps and check the specific gravity of each battery cell with a hydrometer. Note the results.
- 7 Check the ambient air temperature and adjust the specific gravity reading for each cell as follows:
 - Add 0.004 to the reading of each cell for every 5.5°C above 26.7°C.
 - Subtract 0.004 from the reading of each cell for every 5.5°C below 26.7°C.
- ⊙ Result: All battery cells display an adjusted specific gravity of 1.277 or higher. The battery is fully charged. Proceed to step 11.
- ⊗ Result: One or more battery cells display a specific gravity of 1.217 or below. Proceed to step 8.
- 8 Perform an equalizing charge OR fully charge the batteries and allow the batteries to rest at least 6 hours.
- 9 Remove the battery vent caps and check the specific gravity of each battery cell with a hydrometer. Note the results.
- 10 Check the ambient air temperature and adjust the specific gravity reading for each cell as follows:
 - Add 0.004 to the reading of each cell for every 5.5°C above 26.7°C.
 - Subtract 0.004 from the reading of each cell for every 5.5°C below 26.7°C.
- ⊙ Result: All battery cells display a specific gravity of 1.277 or greater. The battery is fully charged. Proceed to step 11.
- ⊗ Result: The difference in specific gravity

Maintenance

readings between cells is greater than 0.1
OR the specific gravity of one or more cells
is less than 1.177. Replace the battery.

- 11 Check the battery acid level. If needed, replenish with distilled water to 3 mm below the bottom of the battery fill tube. Do not overfill.
- 12 Install the vent caps and neutralize any electrolyte that may have spilled.

Note: If you have any further questions regarding the battery charger operation, please contact the DINGLI Service Department.

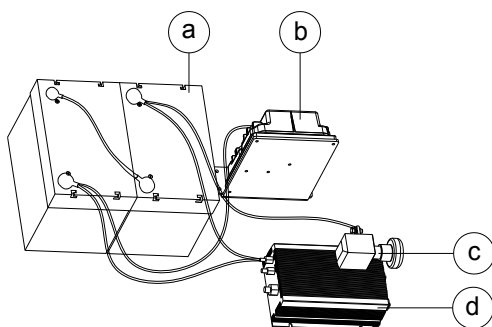

- a batteries
- b 150A fuse
- c power switch
- d battery charger

All models:

- 13 Check each battery pack and verify that the batteries are wired correctly.
 - 14 Inspect the battery charger plug and pigtail for damage or excessive insulation wear. Replace as required.
 - 15 Connect the battery charger to a properly grounded 110 - 230V / 50 - 60 Hz single phase AC power supply.
- ☉ Result: The charger should operate and begin charging the batteries.
 - ☒ Result: If, simultaneously, the charger alarm sounds and the LEDs blink, correct the charger connections at the fuse and battery. The charger will then operate correctly and begin charging the batteries.

Note: For best results, use an extension of adequate size with a length no longer than 15m.

Maintenance

B-2

Inspect the Electrical Wiring



DINGLI requires that this procedure be performed every 250 hours or quarterly, whichever comes first.

Maintaining electrical wiring in good condition is essential to safe operation and good machine performance. Failure to find and replace burnt, chafed, corroded or pinched wires could result in unsafe operating conditions and may cause component damage.

⚠ WARNING Electrocutation / burn hazard. Contact with electrically charged circuits could result in death or serious injury. Remove all rings, watches and other jewelry.

- 1 Inspect the underside of the chassis for damaged or missing ground strap(s).
- 2 Inspect the following areas for burnt, chafed, corroded and loose wires:
 - Ground control panel
 - Hydraulic power unit module tray
 - Platform controls
- 3 Turn the key switch to ground control and pull out the red Emergency Stop button to the on position at both the ground and platform controls.
- 4 Raise the platform approximately 2.2 m from the ground.
- 5 Lift the safety arm, move it to the center of the scissor arm and rotate up to a vertical position.
- 6 Lower the platform onto the safety arm.

⚠ WARNING Crushing hazard. Keep hands clear of the safety arm when lowering the platform.

- 7 Inspect the center chassis area and scissor arms for burnt, chafed and pinched cables.
- 8 Inspect the following areas for burnt, chafed, corroded, pinched and loose wires:
 - Scissor arms
 - ECU to platform controls
 - Power to platform wiring
- 9 Inspect for a liberal coating of dielectric grease in the following locations:
 - Between the ECU and platform controls
 - All wire harness connectors Level sensor
- 10 Raise the platform and return the safety arm to the stowed position.
- 11 Lower the platform to the stowed position and turn the machine off.

Maintenance**B-3****Inspect the Tires and Wheels
(including lock nut torque)**

DINGLI requires that this procedure be performed every 250 hours or quarterly, whichever comes first.

Maintaining the tires and wheels in good condition is essential to safe operation and good performance. Tire and/or wheel failure could result in a machine tip-over. Component damage may also result if problems are not discovered and repaired in a timely fashion.

- 1 Check the tire surface and sidewalls for cuts, cracks, punctures and unusual wear.
- 2 Check each wheel for damage, bends and cracks.
- 3 Check each lock nut for proper torque.

Castle nut torque, dry	25.5Nm
Castle nut torque, lubricated	19.1Nm

B-4**Test the Emergency Stop**

DINGLI requires that this procedure be performed every 250 hours or quarterly, whichever comes first.

A properly functioning Emergency Stop is essential for safe machine operation. An improperly operating red Emergency Stop button will fail to shut off power and stop all machine functions, resulting in a hazardous situation.

As a safety feature, selecting and operating the ground controls will override the platform controls, except the platform red Emergency Stop button.

- 1 Turn the key switch to ground control and pull out the red Emergency Stop button to the on position at both the ground and platform controls.
 - 2 Push in the red Emergency Stop button at the ground controls to the off position.
- ⊙ Result: No machine functions should operate.
- 3 Turn the key switch to platform control and pull out the red Emergency Stop button to the on position at both the ground and platform controls.
 - 4 Push down the red Emergency Stop button at the platform controls to the off position.
- ⊙ Result: No machine functions should operate.

Note: The red Emergency Stop button at the ground controls will stop all machine operation, even if the key switch is switched to platform control.

Maintenance

B-5

Test the Key Switch

DINGLI requires that this procedure be performed every 250 hours or quarterly, whichever comes first.

Proper key switch action and response is essential to safe machine operation. The machine can be operated from the ground or platform controls and the activation of one or the other is accomplished with the key switch. Failure of the key switch to activate the appropriate control panel could cause a hazardous operating situation.

Perform this procedure from the ground using the platform controls. Do not stand in the platform.

- 1 Pull out the red Emergency Stop button to the on position at both the ground and platform controls.
- 2 Turn the key switch to platform control.
- 3 Check the platform up/down function from the ground controls.
- ⊙ Result: The machine functions should not operate.
- 4 Turn the key switch to ground control.
- 5 Check the machine functions from the platform controls.
- ⊙ Result: The machine functions should not operate.
- 6 Turn the key switch to the off position.
- ⊙ Result: No function should operate.

B-6

Test the Automotive-style Horn (if equipped)

DINGLI requires that this procedure be performed every 250 hours or quarterly, whichever comes first.

The horn is activated at the platform controls and sounds at the ground as a warning to ground personnel. An improperly functioning horn will prevent the operator from alerting ground personnel of hazards or unsafe conditions.

- 1 Turn the key switch to platform control and pull out the red Emergency Stop button to the on position at both the ground and platform controls.
- 2 Push down the horn button at the platform controls.
- ⊙ Result: The horn should sound.

B-7**Test the Drive Brakes**

DINGLI requires that this procedure be performed every 250 hours or quarterly, whichever comes first.

Proper brake action is essential to safe machine operation. The drive brake function should operate smoothly, free of hesitation, jerking and unusual noise.

Hydraulically-released individual wheel brakes can appear to operate normally when not fully operational.

Perform this procedure with the machine on a firm level surface that is free of obstructions, with the platform extension deck fully retracted and the platform in the stowed position.

- 1 Mark a test line on the ground for reference.
- 2 Turn the key switch to platform control and pull out the red Emergency Stop button to the on position at both the ground and platform controls.
- 3 Lower the platform to the stowed position.
- 4 Press the drive function select button.
- 5 Choose a point on the machine; i.e., contact patch of a tire, as a visual reference for use when crossing the test line.
- 6 Bring the machine to top drive speed before reaching the test line. Release the function enable switch or the joystick when your reference point on the machine crosses the test line.
- 7 Measure the distance between the test line and your machine reference point.

⊙ Result: The machine stops within the specified braking distance. No action required.

⊗ Result: The machine does not stop within the specified braking distance.

Note: The brakes must be able to hold the machine on any slope it is able to climb.

- 8 Replace the brakes and repeat this procedure beginning with step 1.

Braking distance, maximum

High range on paved surface	61 cm ± 30 cm
-----------------------------	---------------

Maintenance

B-8

Test the Drive Speed - Stowed Position



DINGLI requires that this procedure be performed every 250 hours or quarterly, whichever comes first.

Proper drive functions are essential to safe machine operation. The drive function should respond quickly and smoothly to operator control. Drive performance should also be free of hesitation, jerking and unusual noise over the entire proportionally controlled speed range.

Perform this procedure with the machine on a firm, level surface that is free of obstructions.

- 1 Create start and finish lines by marking two lines on the ground 12.2 m apart.
- 2 Turn the key switch to platform control and pull out the red Emergency Stop button to the on position at both the ground and platform controls.
- 3 Lower the platform to the stowed position.
- 4 Press the drive function select button.
- 5 Choose a point on the machine; i.e., contact patch of a tire, as a visual reference for use when crossing the start and finish lines.
- 6 Bring the machine to top drive speed before reaching the start line. Begin timing when your reference point on the machine crosses the start line.
- 7 Continue at full speed and note the time when your reference point on the machine passes over the finish line. The time is less than 11 sec.

B-9

Test the Drive Speed-Raised Position



DINGLI requires that this procedure be performed every 250 hours or quarterly, whichever comes first.

Proper drive functions are essential to safe machine operation. The drive function should respond quickly and smoothly to operator control. Drive performance should also be free of hesitation, jerking and unusual noise over the entire proportionally controlled speed range.

Perform this procedure with the machine on a firm, level surface that is free of obstructions.

- 1 Create start and finish lines by marking two lines on the ground 12.2 m apart.
- 2 Turn the key switch to platform control and pull out the red Emergency Stop button to the on position at both the ground and platform controls.
- 3 Press the lift function select button.
- 4 Press and hold the function enable switch on the joystick.
- 5 Raise the platform approximately 1.2 m from the ground.
- 6 Press the drive function select button.
- 7 Choose a point on the machine; i.e., contact patch of a tire, as a visual reference for use when crossing the start and finish lines.
- 8 Bring the machine to top drive speed before reaching the start line. Begin timing when your reference point on the machine crosses the start line.
- 9 Continue at full speed and note the time when your reference point on the machine passes over the finish line. The time is less than 40 sec.

Maintenance

B-10

Test the Slow Drive Speed



DINGLI requires that this procedure be performed every 250 hours or quarterly, whichever comes first.

Proper drive functions are essential to safe machine operation. The drive function should respond quickly and smoothly to operator control. Drive performance should also be free of hesitation, jerking and unusual noise over the entire proportionally controlled speed range.

Perform this procedure with the machine on a firm, level surface that is free of obstructions.

- 1 Create start and finish lines by marking two lines on the ground 12.2 m apart.
- 2 Turn the key switch to platform control and pull out the red Emergency Stop button to the on position at both the ground and platform controls.
- 3 Lower the platform to the stowed position.
- 4 Press the slow speed select button.
- 5 Choose a point on the machine; i.e., contact patch of a tire, as a visual reference for use when crossing the start and finish lines.
- 6 Bring the machine to top drive speed before reaching the start line. Begin timing when your reference point on the machine crosses the start line.
- 7 Continue at full speed and note the time when your reference point on the machine passes over the finish line. The time is less than 22 sec.

B-11

Perform Hydraulic Oil Analysis



DINGLI requires that this procedure be performed every 250 hours or quarterly, whichever comes first.

Replacement or testing of the hydraulic oil is essential for good machine performance and service life. Dirty oil may cause the machine to perform poorly and continued use may cause component damage. Extremely dirty conditions may require oil changes to be performed more often.

Before replacing the hydraulic oil, the oil may be tested by an oil distributor for specific levels of contamination to verify that changing the oil is necessary.

If the hydraulic oil is not replaced at the two year inspection, test the oil quarterly. Replace the oil when it fails the test. See E-1, Test or Replace the Hydraulic Oil.

Maintenance

B-12

Inspect the Hydraulic Tank Cap Venting System



DINGLI requires that this procedure be performed quarterly or every 250 hours, whichever comes first. Perform this procedure more often if dusty conditions exist.

A free-breathing hydraulic tank cap is essential for good machine performance and service life. A dirty or clogged cap may cause the machine to perform poorly. Extremely dirty conditions may require that the cap be inspected more often.

- 1 Remove the breather cap from the hydraulic tank.
- 2 Check for proper venting.
 - ☉ Result: Air passes through the breather cap.
 - ☒ Result: If air does not pass through the cap, clean or replace the cap. Proceed to step 3.

Note: When checking for positive tank cap venting, air should pass freely through the cap.

- 3 Using a mild solvent, carefully wash the cap venting system. Dry using low pressure compressed air. Repeat step 2.
- 4 Install the breather cap onto the hydraulic tank.

Maintenance

Checklist C Procedures

C-1

Test the Platform Overload System (if equipped)



DINGLI require that this procedure be performed every 500 hours or six months, whichever comes first OR when the machine fails to lift the maximum rated load.

Testing the platform overload system regularly is essential to safe machine operation. Continued use of an improperly operating platform overload system could result in the system not sensing an overloaded platform condition. Machine stability could be compromised resulting in the machine tipping over.

- 1 Turn the main power switch to "on" position. Turn the key switch to ground control and pull out the red Emergency Stop button to the on position at both the ground and platform controls.



- 2 Press the menu button at the lower right of the page, The display content is as follows:

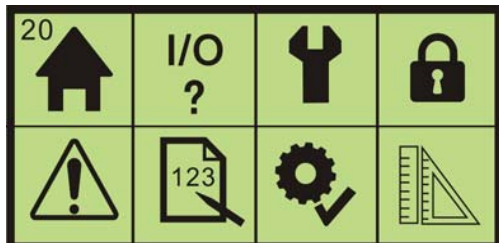

- 3 Press the password button at the top right of the page The display content is as follows:

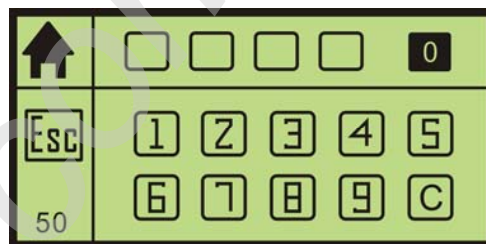

- 4 Enter the password. Press the [ESC] button and return to the display content of step 2.
- 5 Press the [123] button, the display content is as follows:

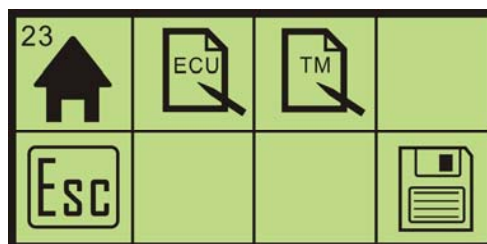

- 6 Press the [ECU] button, the display content is as follows:

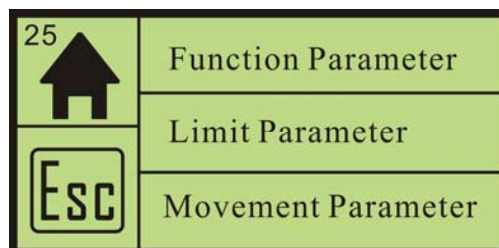

- 7 Press the [limit parameter] button, press the left or right button to choose [height Max Position] and set the page, press[+] button to set the parameter to 120.Press the enter button, The display content is as follows:

Maintenance

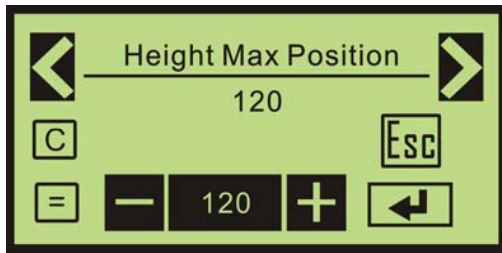

- 8 Press the [ESC] button then return to the display page of step 5.
 - 9 Fully raise the platform. Hold the toggle switch for a moment.
- ⊙ Result -The alarm should sound. The system is functioning correctly.

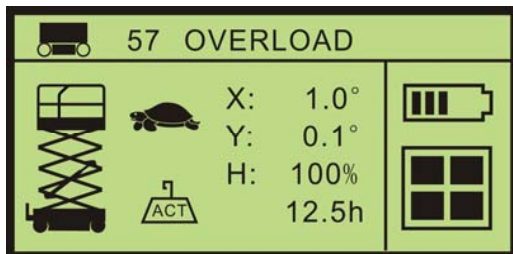

- ⊙ Result: The alarm not sounds. The system is not functioning correctly. Troubleshoot the limit switch, limit switch wire harness or limit switch mount bracket OR the platform overload system needs to be calibrated.
- 10 Lower the platform to the stowed position and turn the machine off.

C-2

Replace the Hydraulic Tank Breather Cap



DINGLI requires that this procedure be performed every 500 hours or semi-annually, whichever comes first.

The hydraulic tank is a vented-type tank. The breather cap has an internal air filter that can become clogged or, over time, can deteriorate. If the breather cap is faulty or improperly installed, impurities can enter the hydraulic system which may cause component damage. Extremely dirty conditions may require that the cap be inspected more often.

- 1 Remove and discard the hydraulic tank breather cap.
- 2 Install a new cap onto the tank.

Checklist D Procedures

D-1

Check the Scissor Arm Wear Pads



DINGLI requires that this procedure be performed every 1000 hours or annually, whichever comes first.

Maintaining the condition of the scissor arm wear pads is essential to safe machine operation. Continued use of worn out wear pads may result in component damage and unsafe operating conditions.

Perform this procedure with the platform in the stowed position.

- 1 Measure the distance between the number one inner arm cross tube and the chassis deck at the ground controls side of the non-steer end of the machine.

Refer to illustration below.

- ☉ Result: The measurement is 30 mm or more. Proceed to step 2.

- ☒ Result: The measurement is less than 30 mm. Replace both wear pads.

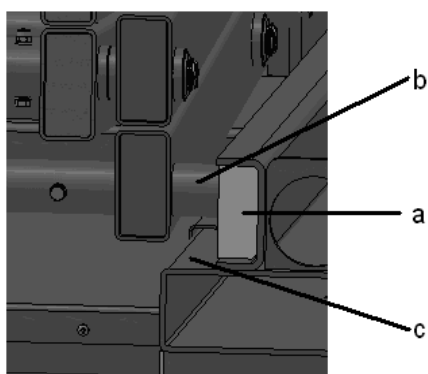

- a wear pad
- b inner arm cross tube
- c chassis deck

- 2 Measure the distance between the number one inner arm cross tube and the chassis deck at the battery pack side of the non-steer end of the machine.

Refer to illustration below.

- ☉ Result: The measurement is 30 mm or more. Proceed to step 3.
 - ☒ Result: The measurement is less than 30mm. Replace both wear pads.
- 3 Apply a thin layer of dry film lubricant to the area of the chassis where the scissor arm wear pads make contact.

Maintenance

Checklist E Procedure

E-1

Test or Replace the Hydraulic Oil



DINGLI requires that this procedure be performed every 2000 hours or every two years, whichever comes first.

Replacement or testing of the hydraulic oil is essential for good machine performance and service life. Dirty oil may cause the machine to perform poorly and continued use may cause component damage. Extremely dirty conditions may require oil changes to be performed more often.

Before replacing the hydraulic oil, the oil may be tested by an oil distributor for specific levels of contamination to verify that changing the oil is necessary.

If the hydraulic oil is not replaced at the two year inspection, test the oil quarterly. Replace the oil when it fails the test.

Note: Perform this procedure with the platform in the stowed position.

- 1 Slide out the tray.
 - 2 Disconnect the battery pack from the machine
- ⚠ WARNING** Electrocutation / burn hazard. Contact with electrically charged circuits could result in death or serious injury. Remove all rings, watches and other jewelry.
- 3 Tag and disconnect the hydraulic pump outlet line and remove the line from the pump. Cap the fitting on the pump.
 - 4 Loose the bolt and remove the hydraulic power pack form the tray.
 - 5 Open the oil plug of tank. Drain all of the oil into a suitable container.

- 6 Loose and remove the bolts and separate the tank from the pump body.

⚠ WARNING Bodily injury hazard.

Spraying hydraulic oil can penetrate and burn skin. Loosen hydraulic connections very slowly to allow the oil pressure to dissipate gradually. Do not allow oil to squirt or spray.

- 7 Clean up any oil that may have spilled. Properly discard the used oil.
- 8 Clean the inside of the hydraulic tank using a mild solvent. Allow the tank to dry completely.
- 9 Install the hydraulic tank and install and tighten the hydraulic tank retaining fasteners. Torque to specification.

Torque specifications

Hydraulic tank retaining fasteners, dry	4 Nm
---	------

Hydraulic tank drain plug, lubricated	2.9 Nm
---------------------------------------	--------

- 10 Install the hydraulic power pack into the tray. Install the fitting and hydraulic hoses onto the hydraulic power pack and torque.
- 11 Fill the tank with hydraulic oil until the fluid is full in the hydraulic tank. Do not overfill.
- 12 Activate the pump to fill the hydraulic system with oil and bleed the system of air.

⚠ WARNING Component damage hazard. The pump can be damaged if operated without oil. Be careful not to empty the hydraulic tank while in the process of filling the hydraulic system. Do not allow the pump to cavitate.

Hydraulic Schematic

